

# DATASHEET

**SIEMENS**

6ES7 193-0CA20-OXAO

**OTHER SYMBOLS:**

**RGB ELEKTRONIKA AGACIAK CIACIEK  
SPÓŁKA JAWNA**

Jana Długosza 2-6 Street  
51-162 Wrocław  
Poland

✉ [biuro@rgbelektronika.pl](mailto:biuro@rgbelektronika.pl)

☎ +48 71 325 15 05



[www.rgbelektronika.pl](http://www.rgbelektronika.pl)



[www.rgbautomatyka.pl](http://www.rgbautomatyka.pl)

# YOUR PARTNER IN MAINTENANCE

Repair **this product** with RGB ELEKTRONIKA

[ORDER A DIAGNOSIS »](#)



At our premises in Wrocław, we have a fully equipped servicing facility. Here we perform all the repair works and test each later sold unit. Our trained employees, equipped with a wide variety of tools and having several testing stands at their disposal, are a guarantee of the highest quality service.

Buy **this product** at RGB AUTOMATYKA

[BUY »](#)

# SIEMENS

## SIMATIC

### ET 200B Distributed I/O Station

#### Manual

EWA 4NEB 812 6089-02b

Edition 3

#### Preface, Contents

---

System Overview

---

**1**

Technical Description

---

**2**

Mechanical and Electrical  
Installation

---

**3**

Address Assignment Parameteri-  
zation with COM ET 200

---

**4**

Startup  
and Test with COM ET 200

---

**5**

Fault Diagnostics

---

**6**

General Technical Specifications

---

**7**

Digital Modules

---

**8**

Analog Modules

---

**9**

Type Files

---

**A**

Safety-Related Guidelines

---

**B**

Glossary, Index

## Safety-Related Guidelines

This manual contains notices intended to ensure personal safety, as well as to protect the products and connected equipment against damage. These notices are highlighted by the symbols shown below and graded according to severity by the following texts:



### Danger

indicates that death, severe personal injury or substantial property damage **will** result if proper precautions are not taken.



### Warning

indicates that death, severe personal injury or substantial property damage **can** result if proper precautions are not taken.



### Caution

indicates that minor personal injury or property damage can result if proper precautions are not taken.

### Note

contains important information about the product, its operation or a part of the document to which special attention is drawn.

## Qualified Personnel

A device/system may only be commissioned or operated by **qualified personnel**. Qualified personnel as referred to in the safety guidelines in this document are persons authorized to energize, ground, and tag circuits, equipment and systems in accordance with established safety practice.

## Proper Usage

Please observe the following:



### Warning

The equipment/system or the system components may only be used for the applications described in the catalog or the technical description, and only in combination with the equipment, components and devices of other manufacturers as far as this is recommended or permitted by Siemens.

The product will function correctly and safely only if it is transported, stored, set up, and installed as intended, and operated and maintained with care.

## Trademarks

SIMATIC® and SINEC® are registered trademarks of SIEMENS AG.

### Copyright

Copyright © Siemens AG 1994 All Rights Reserved

The reproduction, transmission or use of this document or its contents is not permitted without express written authority. Offenders will be liable for damages. All rights, including rights created by patent grant or registration of a utility model or design, are reserved.

### Exclusion of Liability

We have checked the contents of this manual for agreement with the hardware and software described. Since deviations cannot be precluded entirely, we cannot guarantee full agreement. However, the data in this manual is reviewed regularly and any necessary corrections included in subsequent editions. Suggestions for improvement are welcomed.

Technical data subject to change.

# Preface

## Purpose of the Manual

The information contained in this manual will allow you:

- To install, wire and start up the ET 200B distributed I/O station.
- To find module characteristics and technical specifications quickly and easily.

## Contents of the Manual

The following explains the structure of the contents of the manual:

What is the ET 200B?	—————▶	Chap. 1
Which control and display elements does the ET 200B have?	—————▶	Chap. 2
How is the ET 200B installed?	—————▶	Chap. 3
How do I configure an ET 200B (with COM ET 200)?	—————▶	Chap. 4
How do I start up an ET 200B (with COM ET 200)?	—————▶	Chap. 5
Faults?	—————▶	Chap. 6
Technical Specifications?	—————▶	Chap. 7, 8, 9

## Scope of the Manual

This manual describes all the ET 200B modules which can be accessed with the **DP Standard** bus protocol. These ET 200B modules all have a 6ES7 Order Number (see Chapters 8 and 9).

This manual is valid for operation of the ET 200B with:

- IM 308-B master interface module and COM ET 200 V4.x
- IM 308-C master interface module and COM ET 200 WINDOWS

Operation with the IM 308-B master interface module and COM ET 200 V4.x is described in detail in this manual.

**Scope of the Manual (Continued)**

As far as operation of the ET 200B with the IM 308-C master interface module and COM ET 200 WINDOWS is concerned, this manual only explains the parameters which must be set with COM ET 200 WINDOWS. Please refer to the *ET 200 Distributed I/O System* manual (Order No. 6ES5 998-3ES12) for further information about how to use COM ET 200 WINDOWS and for details of the FB IM308C standard function block.

COM ET 200 WINDOWS also provides extensive support for starting up the ET 200B modules through its integrated help system.

**Further Sources**

This manual is based on the master description *ET 200 Distributed I/O System*.

To understand this manual properly, you require the *ET 200 Distributed I/O System* manual.

**Organizational conventions**

The following organizational conventions are used in this manual to make it easier for you to find specific information:

- At the front of the manual is a complete table of contents, together with a list of all the figures and tables contained in the manual.
- The left-hand column of each page in the individual chapters has headings to help you find information more quickly.
- The Appendix is followed by a glossary containing definitions of the most important technical terms used in the manual.
- At the end of the manual is a detailed index which you can use to refer to specific sections.

**Standards**

The ET 200B modules are equivalent to DP Standard slaves in accordance with DIN E 19245, Part 3.

**Questions**

If you have any questions regarding the ET 200B distributed I/O station, please address them to:

SIMATIC Hotline  
Erlangen  
Tel.: +49 9131 7-43344

**Corrections**

At the end of the manual, we have inserted correction forms. Please enter on these your suggestions for corrections and improvements and return the form to us. This will help us to improve the next edition of the manual.

# Contents

<b>1</b>	<b>System Overview</b> .....	<b>1-1</b>
1.1	What is the ET 200? .....	1-2
1.2	What is the ET 200B? .....	1-3
1.2.1	Terminal Block .....	1-5
1.2.2	Electronics Block .....	1-6
<b>2</b>	<b>Technical Description</b> .....	<b>2-1</b>
2.1	Design of the Terminal Block .....	2-2
2.2	Design of the Electronics Block .....	2-4
<b>3</b>	<b>Mechanical and Electrical Installation</b> .....	<b>3-1</b>
3.1	Installing and Setting the Terminal Block .....	3-2
3.2	Installing the Electronics Block .....	3-9
3.3	Dismantling the Terminal Block and the Electronics Block .....	3-11
3.4	Electrical Installation .....	3-12
3.4.1	Grounded Configuration .....	3-13
3.4.2	Ungrounded Configuration .....	3-16
3.5	Wiring the Terminal Block .....	3-18
3.6	Wiring the Bus Interface .....	3-22
<b>4</b>	<b>Address Assignment and Parameterization with COM ET 200</b> .....	<b>4-1</b>
4.1	Address Assignment with COM ET 200 V4.x .....	4-2
4.1.1	Entering the Station Number .....	4-4
4.1.2	Entering the Address Area and the Station Type .....	4-6
4.1.3	Entering the Station Name, Addresses and Address ID .....	4-8
4.2	Entering the Parameterization Frame with COM ET 200 V4x .....	4-13
4.2.1	Parameterizing the ET 200B-4/8AI (6ES7 134-0KH00-0XB0) .....	4-14
4.2.2	Parameterization of the ET 200B-4AI (6ES7 134-0HF00-0XB0) .....	4-17
4.2.3	Parameterization of the ET 200B-4AO (6ES7 135-0HF00-0XB0) .....	4-19
4.2.4	Structure of the Parameterization Frame in KH Format (Summary) ..	4-21
<b>5</b>	<b>Startup and Test with COM ET 200</b> .....	<b>5-1</b>
5.1	Constraints in Operation and Testing .....	5-2
5.2	Startup of the ET 200B Distributed I/O Station .....	5-3
5.3	Testing the ET 200B Distributed I/O Station .....	5-5

<b>6</b>	<b>Fault Diagnostics</b> .....	<b>6-1</b>
6.1	Fault Diagnostics Through LEDs .....	6-2
6.2	Fault Diagnostics with COM ET 200 V4.x .....	6-3
6.3	Fault Diagnostics with STEP 5 (Station Diagnostics) in Combination with an IM 308-B .....	6-5
6.3.1	Diagnostics "Overview" with IM 308-B .....	6-8
6.3.2	Diagnostics "Parameterization and Accessibility" with IM 308-B .....	6-10
6.3.3	Station Status Diagnostics with IM 308-B .....	6-12
6.3.4	Diagnostics of the Manufacturer Identification with IM 308-B .....	6-15
6.3.5	Device-Related Diagnostics (Digital ET 200B) in the Case of Operation with IM308-B .....	6-17
6.3.6	Device-Related Diagnostics (Analog ET 200B) in the Case of Operation with IM 308-B .....	6-19
6.4	Fault Diagnostics with STEP 5 (Station Diagnostics) in Combination with an IM 308-C .....	6-23
6.4.1	Station Status Diagnostics with IM 308-C .....	6-26
6.4.2	Diagnostics of the Manufacturer Identification with IM 308-C .....	6-29
6.4.3	Device-Related Diagnostics (Digital ET 200B) in the Case of Operation with IM 308-C .....	6-31
6.4.4	Device-Related Diagnostics (Analog ET 200B) in the Case of Operation with IM 308-C .....	6-33
<b>7</b>	<b>General Technical Specifications</b> .....	<b>7-1</b>
7.1	General Technical Specifications .....	7-2
<b>8</b>	<b>Digital Modules</b> .....	<b>8-1</b>
8.1	Digital Modules .....	8-2
8.1.1	Terminal Blocks TB1/DC (6ES7 193-0CA10-0XA0), TB1-4/DC (6ES7 193-0CA20-0XA0) and TB3/DC (6ES7 193-0CA30-0XA0) .....	8-4
8.1.2	Terminal Blocks TB2/DC (6ES7 193-0CB10-0XA0), TB2-4/DC (6ES7 193-0CB20-0XA0) and TB4/DC (6ES7 193-0CB30-0XA0) .....	8-8
8.1.3	Terminal Block TB6/AC (6ES7 193-0CC10-0XA0) .....	8-12
8.1.4	Electronics Block ET 200B-16DI (6ES7 131-0BH00-0XB0) .....	8-14
8.1.5	Electronics Blocks ET 200B-32DI (6ES7 131-0BL00-0XB0) and ET 200B-32DI 0.2ms (6ES7 131-0BL10-0XB0) .....	8-19
8.1.6	Electronics Block ET 200B-16DO (6ES7 132-0BH00-0XB0) .....	8-24
8.1.7	Electronics Block ET 200B-16DO/2A (6ES7 132-0BH10-0XB0) .....	8-29
8.1.8	Electronics Block ET 200B-32DO (6ES7 132-0BL00-0XB0) .....	8-34
8.1.9	Electronics Block ET 200B-8RO (6ES7 132-0GF00-0XB0) .....	8-39
8.1.10	Electronics Block ET 200B-8DI/8DO (6ES7 133-0BH00-0XB0) .....	8-44
8.1.11	Electronics Blocks ET 200B-24DI/8DO (6ES7 133-0BN00-0XB0) and ET 200B-24DI/8DO 0.2ms (6ES7 133-0BN10-0XB0) .....	8-49
8.1.12	Electronics Block ET 200B-16DI-AC (6ES7 131-0HF00-0XB0) .....	8-54
8.1.13	Electronics Block ET 200B-16DO-AC (6ES7 132-0HF00-0XB0) .....	8-58
8.1.14	Electronics Block ET 200B-16RO-AC (6ES7 132-0HH00-0XB0) .....	8-62
8.1.15	Electronics Block ET 200B-8DI/8RO-AC (6ES7 133-0HH00-0XB0) ..	8-67



<b>9</b>	<b>Analog Modules</b> .....	<b>9-1</b>
9.1	Analog Modules .....	9-2
9.1.1	Setting and Parameterizing the Analog Modules .....	9-3
9.1.2	TB8 Terminal Block (6ES7 193-0CD40-0XA0) .....	9-5
9.1.3	Electronics Block ET 200B-4/8AI (6ES7 134-0KH00-0XB0) .....	9-7
9.1.4	Electronics Block ET 200B-4AI (6ES7 134-0HF00-0XB0) .....	9-33
9.1.5	Electronics Block ET 200B-4AO (6ES7 135-0HF00-0XB0) .....	9-50
<b>A</b>	<b>Type Files</b> .....	<b>A-1</b>
A.1	Contents of the type file for the COM ET 200 V4.x .....	A-2
<b>B</b>	<b>Safety-Related Guidelines</b> .....	<b>B-1</b>
B.1	Active and Passive Faults in Automation Equipment .....	B-2
B.2	Guidelines for the Planning and Installation of the Product .....	B-3

**Figures**

1-1	ET 200 Bus Node Described in this Manual .....	1-2
1-2	ET 200B Components .....	1-3
2-1	TB1/DC Terminal Block .....	2-2
2-2	TB8 Terminal Block .....	2-3
2-3	ET 200B-16DI Electronics Block .....	2-4
3-1	Clearances Required for Installation of the Electronics Block .....	3-2
3-2	Hanging the Terminal Block on the Standard Sectional Rail and Setting the Coding Slide Switch .....	3-4
3-3	Mounting the Shield Connecting Element on the Standard Sectional Rail .....	3-5
3-4	Mounting the Terminal Block on the Shield Connecting Element .....	3-6
3-5	Hanging the Electronics Block on the Terminal Block .....	3-9
3-6	Dismantling the ET 200B .....	3-11
3-7	Both Screws Tightened in a Grounded Configuration .....	3-14
3-8	Grounded Configuration for 24 V DC Digital Modules of the ET 200B .....	3-14
3-9	Grounded Configuration for 120/230 V AC Digital Modules of the ET 200B .....	3-15
3-10	Upper Screw Removed in an Ungrounded Configuration .....	3-17
3-11	Ungrounded Configuration for 24 V DC Digital Modules of the ET 200 B .....	3-17
3-12	Securing the Wire in a Spring-Loaded Connection .....	3-20
3-13	Shield Connecting Element on Terminal Block TB8 .....	3-21
4-1	“CONFIGURING” Screen Form (1) .....	4-5
4-2	“CONFIGURING” Screen Form (2) .....	4-7
4-3	“CONFIGURING” Screen Form (3) .....	4-10
4-4	Structure of the Parameterization Frame of the ET 200B-4/8AI: Byte 3 .....	4-14
4-5	Structure of the Parameterization Frame of the ET 200B-4/8AI: Byte 4 .....	4-15
4-6	Structure of the Parameterization Frame of the ET 200B-4AI: Byte 3 .....	4-17
4-7	Structure of the Parameterization Frame of the ET 200B-4AO: Byte 3 .....	4-19
5-1	“STARTUP/TEST: STATION SELECTION” Screen Form .....	5-4
5-2	“STARTUP/TEST: STATUS/CONTROL” Screen Form .....	5-6
6-1	“INDIVIDUAL DIAGNOSTICS” Screen Form .....	6-4
6-2	Structure of the Diagnostics Word After Requesting the Diagnostics “Overview” .....	6-9
6-3	Structure of the Diagnostics Word After Requesting the Diagnostics “Parameterization and Accessibility” .....	6-11
6-4	Structure of the Diagnostics Word (Station Status 1 and Station Status 2) .....	6-13
6-5	Structure of the “Station Status 3 and Master Address” Diagnostics Word .....	6-14
6-6	Structure of the “Manufacturer Identification” Diagnostics Word .....	6-16
6-7	Structure of the “Header and Device-Related Diagnostics” Diagnostics Word in the Case of Digital ET 200B Modules .....	6-18
6-8	Structure of the “Header” Diagnostics Word in the Case of Analog ET 200B Modules .....	6-20

6-9	Structure of the "Device-Related Diagnostics (Byte 2)" Diagnostics Word in the Case of Analog ET 200B Modules .....	6-20
6-10	Structure of the "Device-Related Diagnostics (Bytes 3, 4)" Diagnostics Word in the Case of Analog ET 200B Modules .....	6-21
6-11	Structure of the "Device-Related Diagnostics (Byte 5, 6)" Diagnostics Word in the Case of Analog ET 200B Modules .....	6-21
6-12	Structure of the "Device-Related Diagnostics (Byte 7, 8)" Diagnostics Word in the Case of Analog ET 200B Modules .....	6-22
6-13	Structure of the Diagnostics Word (Station Status 1 and Station Status 2) .....	6-27
6-14	Structure of the "Station Status 3 and Master Station Number" Diagnostics Word .....	6-28
6-15	Structure of the "Manufacturer Identification" Diagnostics Word .....	6-30
6-16	Structure of the "Header and Device-Related Diagnostics" Diagnostics Word in the Case of Digital ET 200B Modules" .....	6-32
6-17	Structure of the "Header" Diagnostics Word in the Case of Analog ET 200B Modules .....	6-34
6-18	Structure of the "Device-Related Diagnostics (Byte 2)" Diagnostics Word in the Case of Analog ET 200B Modules .....	6-35
6-19	Structure of the "Device-Related Diagnostics (Bytes 3, 4)" Diagnostics Word in the Case of Analog ET 200B Modules .....	6-35
6-20	Structure of the "Device-Related Diagnostics (Bytes 5, 6)" Diagnostics Word in the Case of Analog ET 200B Modules .....	6-36
6-21	Structure of the "Device-Related Diagnostics (Bytes 7, 8)" Diagnostics Word in the Case of Analog ET 200B Modules .....	6-36
6-22	Structure of the "Header and Device-Related Diagnostics (Bytes 9, 10)" Diagnostics Word in the Case of Analog ET 200B Modules .....	6-37
6-23	Structure of the "Header and Device-Related Diagnostics (Bytes 13, 14)" Diagnostics Word in the Case of Analog ET 200B Modules .....	6-38
8-1	Dimension Drawing: Terminal Block TB1/DC (Screw-Type Terminal, 3-Tier) .....	8-4
8-2	Dimension Drawing: Terminal Block TB1-4/DC (Screw-Type Terminal, 4-Tier) .....	8-5
8-3	Dimension Drawing: Terminal Block TB3/DC (Spring-Loaded Terminal) .....	8-6
8-4	Dimension Drawing: Side Elevation of Terminal Blocks, TB1/DC, TB1-4/DC and TB3/DC with SINEC L2 Bus Connector (6ES7 972-0BA00-0XA0 and 6ES7 972-0BB00-0XA0) .....	8-7
8-5	Dimension Drawing: Side Elevation of Terminal Blocks TB1/DC, TB1-4/DC and TB3/DC with SINEC L2 Bus Connector (6ES5 762-2AA12 and 6ES5 762-2AA21) .....	8-7
8-6	Dimension Drawing: Terminal Block TB2/DC (screw-type terminal, 3-tier) .....	8-8
8-7	Dimension Drawing: Terminal Block TB2-4/DC (screw-type terminal, 4-tier) .....	8-9
8-8	Dimension Drawing: TB4/DC (Spring-loaded terminal) .....	8-10

8-9	Dimension Drawing: Side Elevation of Terminal Blocks TB2/DC, TB2-4/DC and TB4/DC with SINEC L2 Bus Connector (6ES7 972-0BA00-0XA0 and 6ES7 972-0BB00-0XA0) .....	8-11
8-10	Dimension Drawing: Side Elevation of Terminal Blocks TB2/DC, TB2-4/DC and TB4/DC with SINEC L2 Bus Connector (6ES5 762-2AA12 and 6ES5 762-2AA21) .....	8-11
8-11	Dimension Drawing: Terminal Block TB6/AC (screw-type terminal, 3-tier) .....	8-12
8-12	Dimension Drawing: Side Elevation of Terminal Block TB6/AC with SINEC L2 Bus Connector (6ES7 972-0BA00-0XA0 and 6ES7 972-0BB00-0XA0) .....	8-13
8-13	Dimension Drawing: Side Elevation of Terminal Block TB6/AC with SINEC L2 Bus Connector (6ES5 762-2AA12 and 6ES5 762-2AA21) .....	8-13
8-14	Dimension Drawing: ET 200B-16DI (6ES7 131-0BH00-0XB0) .....	8-14
8-15	Schematic Circuit Diagram: ET 200B-16DI (6ES7 131-0BH00-0XB0) and TB1/DC or TB3/DC .....	8-15
8-16	Schematic Circuit Diagram: ET 200B-16DI (6ES7 131-0BH00-0XB0) and TB1-4/DC .....	8-16
8-17	Dimension Drawing: ET 200B-32DI (6ES7 131-0BL00-0XB0) and ET 200B-32DI 0.2ms (6ES7 131-0BL10-0XB0) .....	8-19
8-18	Schematic Circuit Diagram: ET 200B-32DI (6ES7 131-0BL00-0XB0) or ET 200B-32DI 0.2ms (6ES7 131-0BL10-0XB0) and TB2/DC or TB4/DC .....	8-20
8-19	Schematic Circuit Diagram: ET 200B-32DI (6ES7 131-0BL00-0XB0) or ET 200B-32DI 0.2 ms (6ES7 131-0BL10-0XB0) and TB2-4/DC ...	8-21
8-20	Front Elevation: ET 200B-16DO (6ES7 132-0BH00-0XB0) .....	8-24
8-21	Schematic Circuit Diagram: ET 200B-16DO (6ES7 132-0BH00-0XB0) and TB1/DC or TB3/DC .....	8-25
8-22	Schematic Circuit Diagram: ET 200B-16DO (6ES7 132-0BH00-0XB0) and TB1-4/DC .....	8-26
8-23	Front Elevation: ET 200B-16DO/2A (6ES7 132-0BH10-0XB0) .....	8-29
8-24	Schematic Circuit Diagram: ET 200B-16DO/2A (6ES7 132-0BH10-0XB0) and TB2/DC or TB4/DC .....	8-30
8-25	Schematic Circuit Diagram: ET 200B-16DO/2A (6ES7 132-0BH10-0XB0) and TB2-4/DC .....	8-31
8-26	Front Elevation: ET 200B-32DO (6ES7 132-0BL00-0XB0) .....	8-34
8-27	Schematic Circuit Diagram: ET 200-B-32DO (6ES7 132-0BL00-0BX0) and TB2/DC or TBA/DC .....	8-35
8-28	Schematic Circuit Diagram: ET 200B-32DO (6ES7 132-0BL00-0XB0) and TB2-4/DC .....	8-36
8-29	Front Elevation: ET 200B-8RO (6ES7 132-0GF00-0XB0) .....	8-39
8-30	Schematic Circuit Diagram: ET 200B-8RO (6ES7 132-0GF00-0XB0) and TB1/DC or TB3/DC .....	8-40
8-31	Schematic Circuit Diagram: ET 200B-8RO (6ES7 132-0GF00-0XB0) and TB1-4/DC .....	8-41
8-32	Front Elevation: ET 200B-8DI/8DO (6ES7 133-0BH00-0XB0) .....	8-44
8-33	Schematic Circuit Diagram: ET 200B-8DI/8DO (6ES7 133-0BH00-0XB0) and TB1/DC or TB3/DC .....	8-45
8-34	Schematic Circuit Diagram: ET 200B-8DI/8DO (6ES7 133-0BH00-0XB0) and TB1-4/DC .....	8-46

8-35	Front Elevation: ET 200B-24DI/8DO (6ES7 133-0BN00-0XB0) and ET 200B-24DI/8DO 0.2ms (6ES7 133-0BN10-0XB0) .....	8-49
8-36	Schematic Circuit Diagram: ET 200B-24DI/8DO (6ES7 133-0BN00-0XB0) or ET 200B-24DI/8DO 0.2 ms (6ES7 133-0BN10-0XB0) and TB2/DC or TB4/DC .....	8-50
8-37	Schematic Circuit Diagram: ET 200B-24DI/8DO (6ES7 133-0BN00-0XB0) or ET 200B-24DI/8DO 0.2 ms (6ES7 133-0BN10-0XB0) and TB2-4/DC .....	8-51
8-38	Front Elevation: ET 200B-16DI-AC (6ES7 131-0HF00-0XB0) .....	8-54
8-39	Schematic Circuit Diagram: ET 200B-16DI-AC (6ES7 131-0HF00-0XB0) and TB6/AC .....	8-55
8-40	Front Elevation: ET 200B-16DO-AC (6ES7 132-0HF00-0XB0) .....	8-58
8-41	Schematic Circuit Diagram: ET 200B-16DO-AC (6ES7 132-0HF00-0XB0) and TB6/AC .....	8-59
8-42	Front Elevation: ET 200B-16RO-AC (6ES7 132-0HH00-0XB0) .....	8-62
8-43	Schematic Circuit Diagram: ET 200B-16RO-AC (6ES7 132-0HH00-0XB0) and TB6/AC .....	8-63
8-44	Front Elevation: ET 200B-8DI/8RO-AC (6ES7 133-0HH00-0XB0) ...	8-67
8-45	Schematic Circuit Diagram: ET 200B-8DI/8RO-AC (6ES7 133-0HH00-0XB0) and TB6/AC .....	8-68
9-1	Changing the Setting of the Coding Plug .....	9-4
9-2	Dimension Drawing: TB8 Terminal Block (Spring-Loaded Terminal) ..	9-5
9-3	Dimension Drawing: Side Elevation of the Terminal Block TB8 with SINEC L2 Bus Connector (6ES7 972-0BA00-0XA0 and 6ES7 972-0BB00-0XA0) .....	9-6
9-4	Dimension Drawing: Side Elevation of the Terminal Block TB8 with SINEC L2 Bus Connector (6ES5 762-2AA12 and 6ES5 762-2AA21) ..	9-6
9-5	Dimension Drawing: ET 200B-4/8AI (6ES7 134-0KH00-0XB0) .....	9-7
9-6	Connection of Thermocouples with a Compensating Box (Floating-Ground Measurement) .....	9-12
9-7	Connection of Thermocouples with a Compensating Box (Ground-Referenced Measurement) .....	9-13
9-8	Connection of Resistance Thermometers (Pt 100) with 2-Wire Connections (Floating-Ground Measurement) .....	9-14
9-9	Connection of Resistance Thermometers (Pt 100) with 2-Wire Connections (Ground-Referenced Measurement) .....	9-15
9-10	Connection of Resistance Thermometers (Pt 100) with 4-Wire Connections (Floating-Ground Measurement) .....	9-16
9-11	Connection of Resistance Thermometers (Pt 100) with 4-Wire Connections (Ground-Referenced Measurement) .....	9-17
9-12	Two-Wire Connection of Voltage Sensors to 6ES7 134-0KH00-0XB0 (Floating-Ground Measurement) .....	9-18
9-13	Two-Wire Connection of Voltage Sensors to 6ES7 134-0KH00-0XB0 (Ground-Referenced Measurement) .....	9-19
9-14	Schematic Circuit Diagram: ET 200B-4/8AI (6ES7 134-0KH00-0XB0) and TB8 .....	9-29
9-15	Front Elevation: ET 200B-4AI (6ES7 134-0HF00-0XB0) .....	9-33
9-16	Two-Wire Connection of Voltage Sensors to 6ES7 134-0HF00-0XB0 (Floating-Ground Measurement) .....	9-36
9-17	Two-Wire Connection of Voltage Sensors 6ES7 134-0HF00-0XB0 (Ground-Referenced Measurement) .....	9-37

9-18	Two-Wire Connection of Current Sensors (Floating-Ground Measurement) .....	9-38
9-19	Two-Wire Connection of Current Sensors (Ground-Referenced Measurement) .....	9-39
9-20	Schematic Circuit Diagram: ET 200B-4AI (6ES7 134-0HF00-0XB0) and TB8 .....	9-47
9-21	Front Elevation: ET 200B-4AO (6ES7 135-0HF00-0XB0) .....	9-50
9-22	4-Wire Connection of Loads in the Case of Voltage Output .....	9-52
9-23	2-Wire Connection of Loads in the Case of Voltage Output .....	9-53
9-24	2-Wire Connection of Loads in the Case of Current Output .....	9-54
9-25	Schematic Circuit Diagram: ET 200B-4AO (6ES7 135-0HF00-0XB0) and TB8 .....	9-58

**Tables**

3-1	Assignment of the Electronics Blocks to the Coding Slide Switch . . . . .	3-7
3-2	Permissible Fuses in the Terminal Block . . . . .	3-8
3-3	Pin Assignments of the Terminal Block . . . . .	3-19
3-4	SINEC L2 Bus Connectors . . . . .	3-22
4-1	Designation of the Type Files for the ET 200B . . . . .	4-2
4-2	Address IDs for ET 200B . . . . .	4-9
4-3	Parameters for the ET 200B-4/8AI (Bytes 6 to 10 of the Parameterization Frame) . . . . .	4-16
4-4	Parameters for the ET 200B-4AI (Bytes 7 to 10 of the Parameterization Frame) . . . . .	4-18
4-5	Parameters for the ET 200B-4AO (Bytes 7 to 10 of the Parameterization Frame) . . . . .	4-20
4-6	Contents and Meaning of the Bytes . . . . .	4-21
6-1	LED Indicators . . . . .	6-2
6-2	Diagnostics Functions Using STEP 5 in combination with an IM 308-B . . . . .	6-5
6-3	Structure of the Station Diagnostics for the ET 200B in combination with an IM 308-B . . . . .	6-6
6-4	Combination of Diagnostics “Overview” and Diagnostics “Parameterization and Accessibility” . . . . .	6-11
6-5	Diagnostics Functions Using STEP 5 in Combination with an IM 308-C . . . . .	6-23
6-6	Structure of the Station Diagnostics for the ET 200B in Combination with an IM 308-C . . . . .	6-24
6-7	Position of the Diagnostics Data in a Data Block . . . . .	6-26
6-8	Position of the Diagnostics Data in a Data Block (Digital ET 200B) . . .	6-31
6-9	Position of the Diagnostics Data in the Data Block (Analog ET 200B) . . . . .	6-33
8-1	ET 200B Digital Electronics Blocks (24 V DC) . . . . .	8-2
8-2	ET 200B Digital Terminal Blocks . . . . .	8-3
8-3	Terminal Assignments of Terminal Blocks TB1/DC, TB2-4/DC and TB3/DC for the ET 200B-16DI (6ES7 131-0BH00-0XB0) . . . . .	8-17
8-4	Terminal Assignments of Terminal Blocks TB2/DC, TB2-4/DC and TB4/DC8-22 for ET 200B-32DI (6ES7 131-0BL00-0XB0) and ET 200B-32DI 0.2ms (6ES7 131-0BL10-0XB0) . . . . .	8-22
8-5	Terminal Assignments of Terminal Blocks TB1/DC, TB1-4/DC and TB3/DC for ET 200B-16DO (6ES7 132-0BH00-0XB0) . . . . .	8-27
8-6	Terminal Assignments of Terminal Blocks TB2/DC, TB2-4/DC and TB4/DC for ET 200B-16DO/2A (6ES7 132-0BH10-0XB0) . . . . .	8-32
8-7	Terminal Assignments of Terminal Blocks TB2/DC, TB2-4/DC and TB4/DC for ET 200B-32DO (6ES7 132-0BL00-0XB0) . . . . .	8-37
8-8	Terminal Assignments of Terminal Blocks TB1/DC, TB1-4/DC and TB3/DC for ET 200B-8RO (6ES7 132-0GF00-0XB0) . . . . .	8-42
8-9	Terminal Assignments of Terminal Blocks TB1/DC, TB1-4/DC and TB3/DC for ET 200B-8DI/8DO (6ES7 133-0BH00-0XB0) . . . . .	8-47
8-10	Terminal Assignments of Terminal Blocks TB2/DC, TB2-4/DC and TB4/DC for ET 200B-24DI/8DO (6ES7 133-0BN00-0XB0) and ET 200B-24DI/8DO 0.2ms (6ES7 133-0BN10-0XB0) . . . . .	8-52
8-11	Terminal Assignments of Terminal Block TB6/AC for ET 200B-16DI-AC (6ES7 131-0HF00-0XB0) . . . . .	8-56

8-12	Terminal Assignments of Terminal Block TB6/AC for ET 200B-16DO-AC (6ES7 132-0HF00-0XB0) .....	8-60
8-13	Terminal Assignments of Terminal Block TB6/AC for ET 200B-16RO-AC (6ES7 132-0HH00-0XB0) .....	8-64
8-14	Terminal Assignments of Terminal Block TB6/AC for ET 200B-8DI/8RO-AC (6ES7 133-0HH00-0XB0) .....	8-69
9-1	Analog Electronics Blocks of the ET 200B .....	9-2
9-2	Analog Terminal Block of the ET 200B .....	9-2
9-3	Compensating Box Type U with Current Stabilizer. ....	9-10
9-4	Reference Junction with Built-In Power Supply Unit .....	9-11
9-5	Parameters for ET 200B-4/8AI .....	9-20
9-6	Representing an Analog Input Value as a Bit Pattern (6ES7 134-0KH00-0XB0) .....	9-22
9-7	Description of the Bits (6ES7 134-0KH00-0XB0) .....	9-22
9-8	Representation of Digitized Measured Values of the ET 200B-4/8AI (6ES7 134-0KH00-0XB0; Measuring Ranges: " 80 mV, " 250 mV, " 500 mV and " 1000 mV; Two's Complement) ...	9-23
9-9	Representation of Digitized Measured Values of the ET 200B-4/8AI (6ES7 134-0KH00-0XB0; Measuring Ranges: " 80 mV, " 250 mV, " 500 mV and " 1000 mV; Amount and Sign) .....	9-24
9-10	Representation of Digitized Measured Values of the ET 200B-4/8AI in the Case of Resistance Thermometers (Two's Complement) .....	9-25
9-11	Representation of Digitized Measured Values of the ET 200B-4/8AI with Linearization: Thermocouple Type K (Nickel-Chromium/ Nickel-Aluminum, to IEC 584) (Two's Complement) .....	9-26
9-12	Representation of Digitized Measured Values of the ET 200B-4/8AI with Linearization: Thermocouple Type J (Iron/Copper-Nickel (Constantan), to IEC 584) (Two's Complement) .....	9-27
9-13	Representation of Digitized Measured Values of the ET 200B-4/8AI with Linearization: Thermocouple Type L (Iron/Copper-Nickel (Constantan), to DIN 43710) (Two's Complement) .....	9-28
9-14	Terminal Assignments of the TB8 for ET 200B-4/8AI (6ES7 134-0KH00-0XB0) .....	9-30
9-15	Parameter für ET 200B-4AI .....	9-40
9-16	Representing an Analog Input Value as a Bit Pattern (6ES7 134-0HF00-0XB0) .....	9-41
9-17	Description of the Bits (6ES7 134-0HF00-0XB0) .....	9-41
9-18	Representation of Digitized Measured Values of the ET 200B-4AI (6ES7 134-0HF00-0XB0; Measuring Ranges: $\pm 1.25$ V, $\pm 2.5$ V, $\pm 5$ V, $\pm 10$ V; Two's Complement) .....	9-42
9-19	Representation of Digitized Measured Values of the ET 200B-4AI (6ES7 134-0HF00-0XB0; Measuring Ranges: $\pm 1.25$ V, $\pm 2.5$ V, $\pm 5$ V, $\pm 10$ V; Amount and Sign) .....	9-42
9-20	Representation of Digitized Measured Values of the ET 200B-4AI (6ES7 134-0HF00-0XB0; Measuring Ranges: $\pm 1.25$ V, $\pm 2.5$ V, $\pm 5$ V, $\pm 10$ V; Binary) .....	9-43
9-21	Representation of Digitized Measured Values of the ET 200B-4AI (6ES7 134-0HF00-0XB0; Measuring Range: $\pm 20$ mA; Two's Complement) .....	9-44



9-22	Representation of Digitized Measured Values of the ET 200B-4AI (6ES7 134-0HF00-0XB0; Measuring Range: $\pm 20$ mA; Amount and Sign) .....	9-44
9-23	Representation of Digitized Measured Values of the ET 200B-4AI (6ES7 134-0HF00-0XB0; Measuring Range: $\pm 20$ mA; Binary) .....	9-45
9-24	Representation of Digitized Measured Values of the ET 200B-4AI (6ES7 134-0HF00-0XB0; Measuring Range: 0 to 20 mA) .....	9-45
9-25	Representation of Digitized Measured Values of the ET 200B-4AI (6ES7 134-0HF00-0XB0; Measuring Range: 4 to 20 mA) .....	9-46
9-26	Terminal Assignments of the TB8 for ET 200B-4AI (6ES7 134-0HF00-0XB0) .....	9-48
9-27	Parameters for the ET 200B-4AO .....	9-55
9-28	Representing an Analog Input Value as a Bit Pattern (6ES7 135-0HF00-0XB0) .....	9-56
9-29	Description of the Bits (6ES7 135-0HF00-0XB0) .....	9-56
9-30	Analog Output Signals of the ET 200B-4AO (Value Ranges: $\pm 10$ V, 0 to 10 V, $\pm 20$ mA, 0 to 20 mA, 4 to 20 mA; Two's Complement) .....	9-57
9-31	Terminal Assignments of the TB8 for ET 200B-4AO (6ES7 135-0HF00-0XB0) .....	9-59

# System Overview

# 1

## In this Chapter

The System Overview gives you information on the following:

- The place of the ET 200B distributed I/O station in the ET 200 distributed I/O system.
- The components that make up the ET 200B.

## 1.1 What is the ET 200?

### Definition

The ET 200 distributed I/O system is based on the PROFIBUS standard (DIN 19245, Part 1) and the PROFIBUS-DP draft standard (DIN 19245, Part 3).

The SIEMENS PROFIBUS is called SINEC L2.

The field bus on which the ET 200 distributed I/O system is based is a variant of SINEC L2 called SINEC L2-DP. This version is designed for communication with distributed I/O at extremely short response times.

### Bus Node Described in this Manual

The distributed I/O system consists of active and passive nodes, the SINEC L2-DP field bus and the SINEC L2 network components. The ET 200B distributed I/O station is a passive bus node (slave).

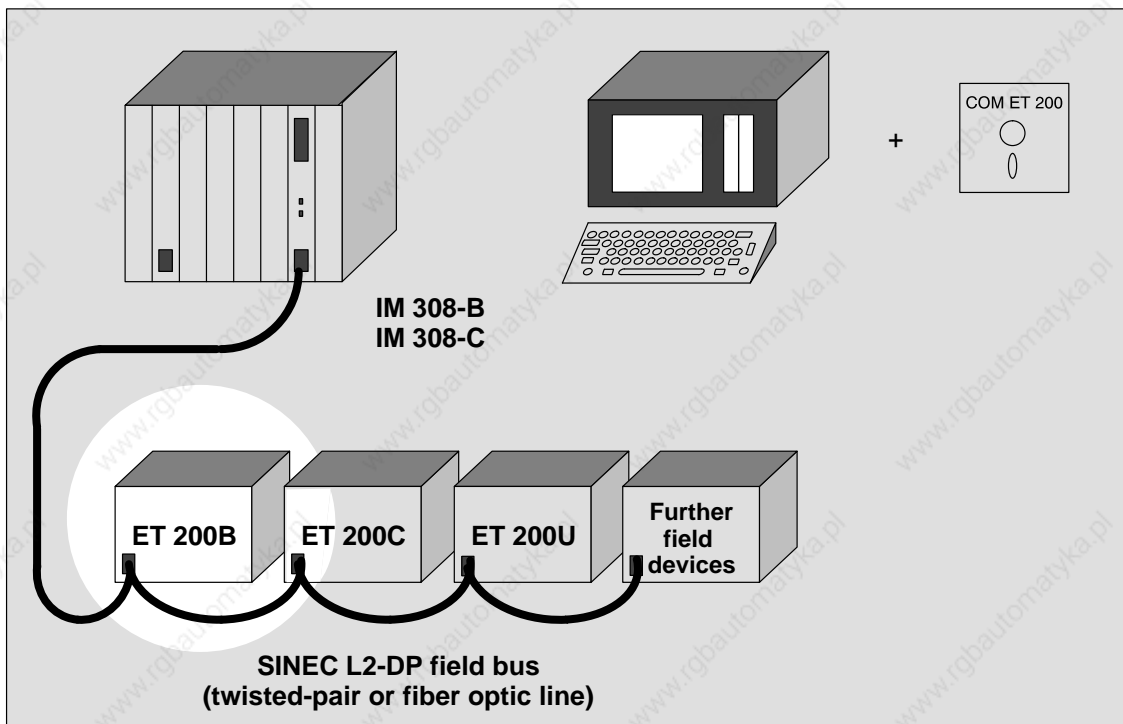

Figure 1-1 ET 200 Bus Node Described in this Manual

## 1.2 What is the ET 200B?

### Definition

The ET 200B distributed I/O station (B for block I/O) belongs to the ET 200 distributed I/O system with the SINEC L2-DP field bus. The ET 200B is a slave station with degree of protection IP 20.

The ET 200B distributed I/O station incorporates a SINEC L2-DP bus interface and digital or analog inputs/outputs.

### Range of Modules

The range of modules for the ET 200B includes:

- 24 V DC digital modules
- 120/230 V AC digital modules
- Analog modules

### Application

Thanks to its compact and flat design, the ET 200B distributed I/O station is primarily suited to applications where space is a priority.

The ET 200B distributed I/O station can be mounted either on a standard sectional rail or directly onto the wall. Vertical and horizontal installation are both possible.

### Components

The ET 200B consists of 2 parts: the terminal block and the electronics block.

The terminal block (TB) incorporates the permanent wiring and does not contain any function-related electrical components. The electronics block is attached to the terminal block. The electronics block (EB) contains the logic circuits.

The terminal block and the electronics block have matching mechanical coding elements to prevent destruction of the electronics block.

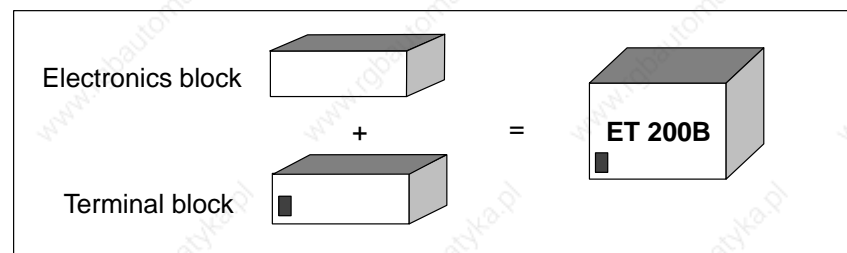

Figure 1-2 ET 200B Components

## What is the ET 200B?, continued

### Characteristics

All the ET 200B modules can be accessed with the **DP Standard** bus protocol.

---

### Note

The ET 200B can be operated with the following master interface modules and versions of COM ET 200:

- IM 308–B (Version 5 or higher) and COM ET 200 (Version 4.0 or higher, see Chapters 4 and 5)

or

- IM 308–C (Version 1 or higher) and COM ET 200 WINDOWS.
- 

### DP Standard

DP Standard is the bus protocol of the ET 200 distributed I/O system in accordance with the Draft Standard DIN 19245, Part 3.

## 1.2.1 Terminal Block

### Definition

The terminal block incorporates the permanent wiring.

### Characteristics

The terminal block has the following characteristics:

- The supply voltage for the electronics block (logic) can be switched on/off (except for the TB6/AC terminal block).
- The terminal block can be mounted both on standard sectional rails and on smooth surfaces, that is, direct wall mounting is possible.
- The SINEC L2-DP bus is interfaced via a SINEC L2 bus connector.
- Station numbers between 00 and 99 can be set by means of an implement such as a screwdriver:
  - When operating with an IM 308-B master interface, station numbers 3 to 99 are permissible.
  - When operating with an IM 308-C master interface, station numbers 1 to 99 are permissible.

## 1.2.2 Electronics Block

### Definition

The electronics block contains the logic circuits and is plugged onto the terminal block.

### Characteristics

The electronics block has the following characteristics:

- There is galvanic isolation between the SINEC L2-DP bus and the internal electronics.
- The block has LEDs for indicating the following:
  - Voltage supply to the logic circuits (RUN)
  - Bus fault (BF)
  - Group diagnostics: short-circuit, wire break or load voltage failure (DIA, only for electronics blocks which can be diagnosed)
  - Load voltage monitoring (L1+, L2+, L3+, L4+, only for digital electronics blocks (24 V DC) with output channels)
  - Status of the inputs or outputs (for digital electronics blocks only)
- Labelling strips are inserted in the electronics block. Fill in the labelling strips to ensure unambiguous assignment of name, channel and LED.

# Technical Description

# 2

## **In this Chapter**

This chapter contains overviews showing the arrangement of the following:

- Operator controls
- Display elements
- Elements for assembling/dismantling.



## 2.1 Design of the Terminal Block

### Design Principle of the Digital TBs

All digital terminal blocks are built on the same design principle explained below using the TB1/DC terminal block as a typical example:

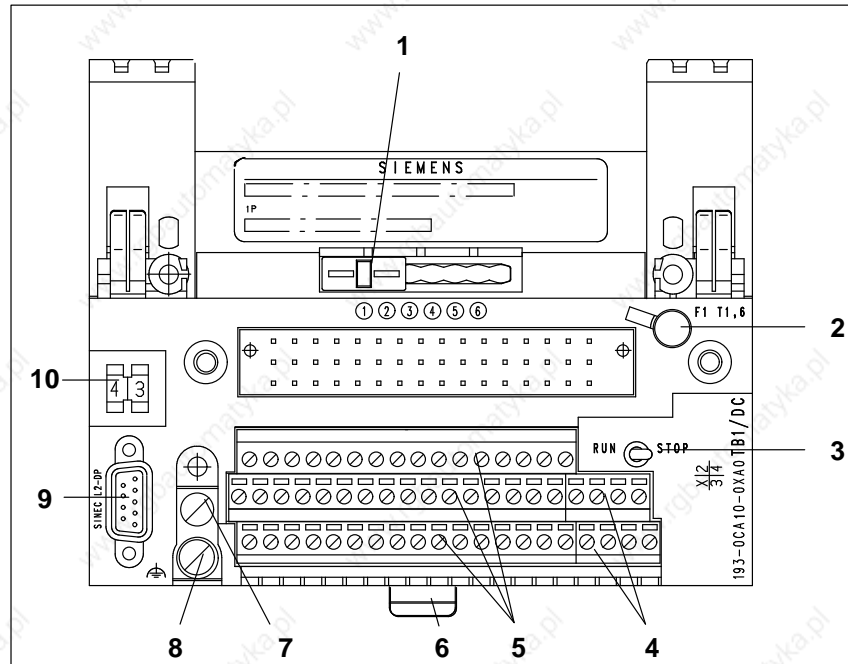

Figure 2-1 TB1/DC Terminal Block

- 1 Coding slide switch
- 2 Fuse
- 3 STOP/RUN switch (not TB6/AC). The power supply for logic circuits in the electronics block can be switched on or off with the STOP/RUN switch. It can also be used to switch the ET 200B distributed I/O station on and off.
- 4 Terminals for power supplies
- 5 Terminals for inputs/outputs
- 6 Slide for removing the terminal block from the standard sectional rail
- 7 M4 screw (connects chassis with PE)
- 8 M5 screw for connecting PE
- 9 SINEC L2-DP interface
- 10 Switch for setting the station number (the station number is valid only after operation of the STOP/RUN switch (STOP → RUN)).

### Design Principle of the TB8 Analog Block

On the front of the TB8 analog terminal block, there are an additional 5 coding switches:

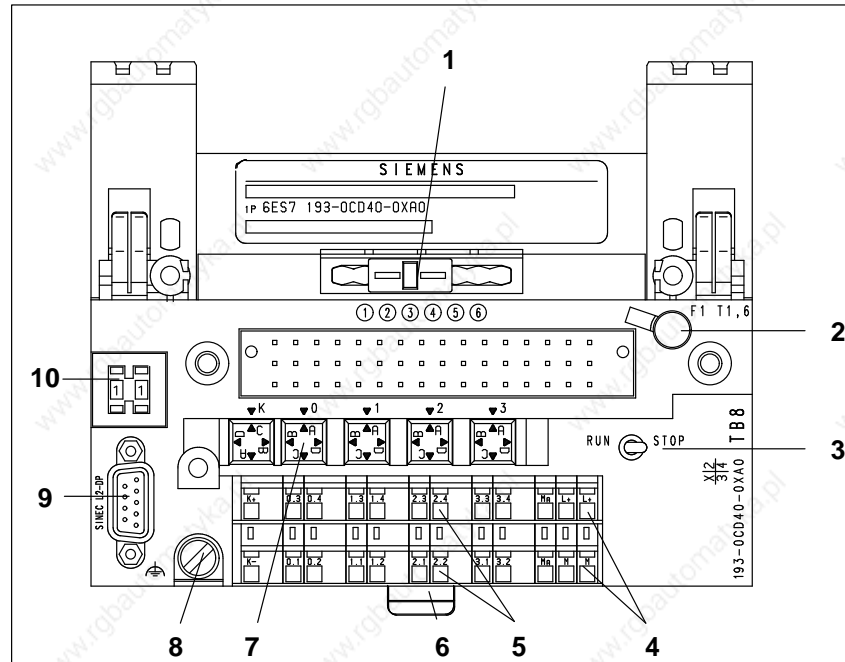

Figure 2-2 TB8 Terminal Block

- 1 Coding slide switch
- 2 Fuse
- 3 STOP/RUN switch. The power supply for logic circuits in the electronics block can be switched on or off with the STOP/RUN switch. It can also be used to switch the ET 200B distributed I/O station on and off.
- 4 Terminals for power supplies
- 5 Terminals for inputs/outputs
- 6 Slide for removing the terminal block from the standard sectional rail
- 7 Coding connectors. You use the coding connectors for setting the wiring of the TB8 for analog value processing.
- 8 M5 screw for connecting PE
- 9 SINEC L2-DP interface
- 10 Switch for setting the station number (the station number is valid only after operation of the STOP/RUN switch (STOP → RUN)).

## 2.2 Design of the Electronics Block

### Design Principle

All types of electronics block are built on the same design principle which is explained below using the ET 200B-16DI electronics block as a typical example:

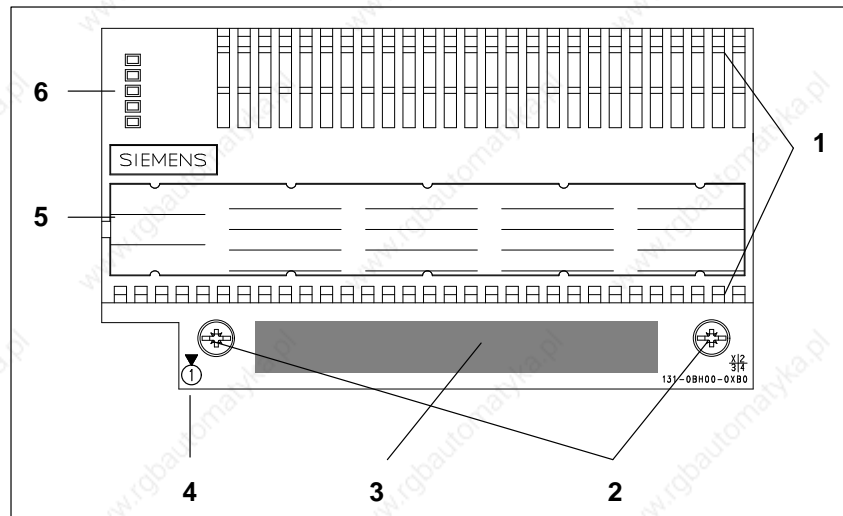

Figure 2-3 ET 200B-16DI Electronics Block

- 1 Ventilation slots
- 2 Screws for mounting the electronics block on the terminal block
- 3 Printed schematic diagram
- 4 Indication of the coding slide switch setting on the top of the terminal block
- 5 Labelling strip; for indicating the status of the inputs or outputs in the case of digital electronics blocks with LEDs
- 6 LEDs for
  - Voltage supply to the logic circuits (RUN)
  - Bus fault (BF)
  - Group diagnostics; short-circuit, wire break or load voltage failure (DIA, only for electronics blocks which can be diagnosed)
  - Monitoring the load voltage (L1+ for ET 200B-8DI/8DO, ET 200B-24DI/8DO and ET 200B-24DI/8DO 0.2 ms; L1+, L2+ for ET 200B-16DQ; L1+/L2+, L3+/L4+ for ET 200B-32DO and ET 200B-16DO/2A).

### Coding

The electronics blocks are coded by the manufacturer. Some types of electronics blocks have a recess at the bottom. This recess ensures that the terminal block is assigned safely to the correct electronics block.

# Mechanical and Electrical Installation

# 3

## In this Chapter

In this chapter, you will find out

- How to install the terminal block and the electronics block.
- The settings to be made on the terminal block.
- How to perform the electrical wiring on the terminal block.

You will find a detailed description of the technical specifications of the ET 200B modules in Chapters 7, 8 and 9.

### 3.1 Installing and Setting the Terminal Block

#### Two Methods

You can install the terminal block either

- on a standard sectional rail (35 x 15 mm or 35 x 7.5 mm to DIN EN 50022)
- or
- on smooth surfaces, that is, direct wall mounting (for dimensions of the mounting holes see Dimension Drawings in Chapters 8 and 9).

#### Installation Clearances

Figure 3-1 shows you the minimum clearances that are required to hang the electronics block on the standard sectional rail:

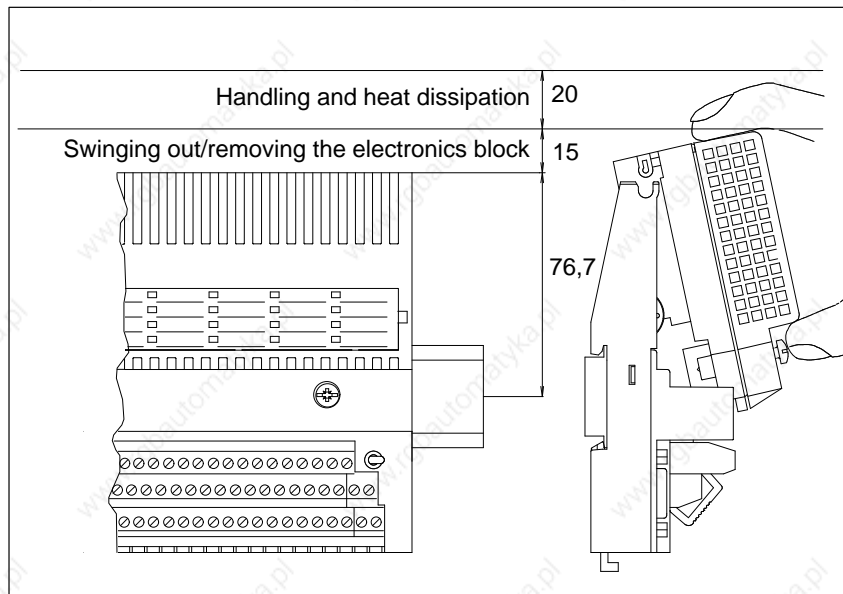

Figure 3-1 Clearances Required for Installation of the Electronics Block

### Shield Connecting Element for TB8

In the case of analog value processing, we recommend that the cable shielding of the signal lines is applied directly at terminal block TB8.

For this application, you can hang the TB8 onto a shield connecting element after first mounting the shield connecting element on a standard sectional rail (35 x 15 or 35 x 7.5 mm to DIN EN 50022) or a smooth surface.

To apply the shield braiding, install metal terminal elements on the shield connecting element.

You can order the shield connecting element and the terminal elements under the following numbers:

- Shield connecting element → Order no. 6ES7 193-0CD40-7XA0
- Terminal elements (1 pair each):
  - Single version → Order no. 6ES7 390-5BA00-0AA0  
(one shield cable per terminal element with a diameter of 3 to 8 mm to be clamped)
  - Double version → Order no. 6ES7 390-5BA00-0AA0  
(two shield cables per terminal element with a diameter of 2 to 6 mm to be clamped)

---

#### Note

If you mount the TB8 with shield connecting element on a standard sectional rail, you must install the ET 200B horizontally.

---

## Installing and Setting the Terminal Block, continued

### Mounting on a Standard Sectional Rail

If you mount the terminal block on a standard sectional rail...

1. Hang the terminal block on the standard sectional rail (1) and
2. Swing it back until the slide on the module snaps into place (2).

#### Note:

The meanings of the coding switch settings are explained in Table 3-1.

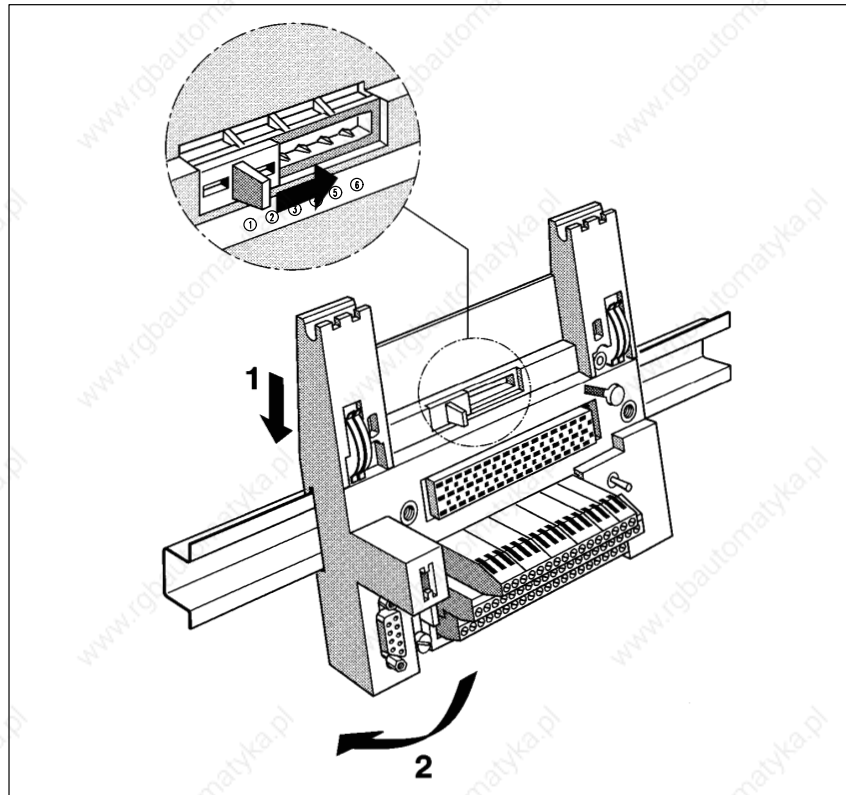

Figure 3-2 Hanging the Terminal Block on the Standard Sectional Rail and Setting the Coding Slide Switch

**Mounting with  
Shield Connecting  
Element on a  
Standard Sectional  
Rail**

If you mount the terminal block with shield connecting element on a standard sectional rail...

1. Hang the shield connecting element on the standard sectional rail from below (1) and swing it back (2).
2. Secure the shield connecting element on the standard sectional rail by tightening the screws (3).

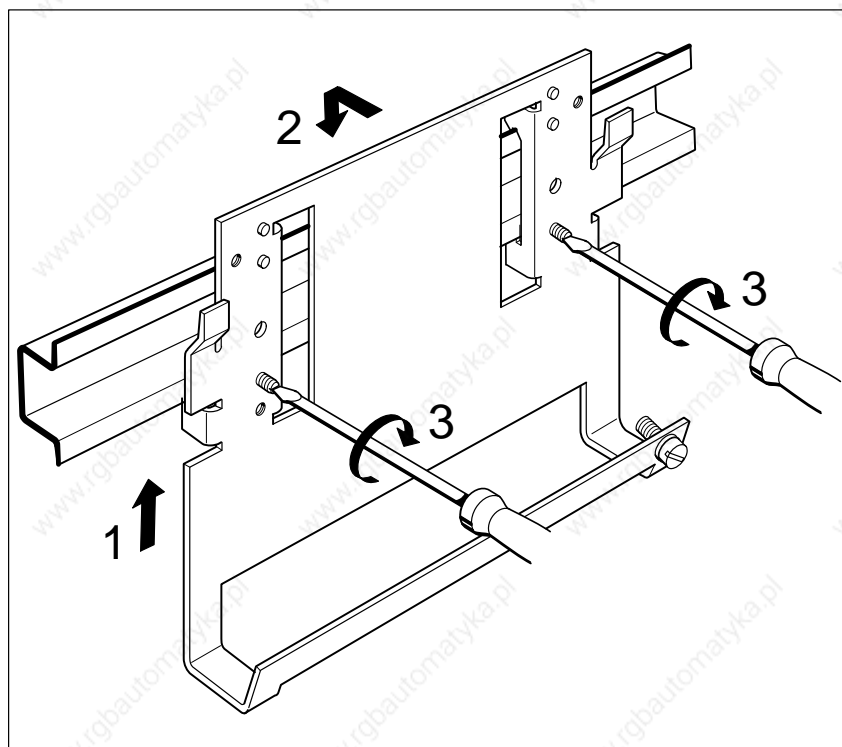

Figure 3-3 Mounting the Shield Connecting Element on the Standard Sectional Rail



## Installing and Setting the Terminal Block, continued

3. Hang the terminal block on the supporting lugs of the shield connecting element (4).
4. Secure the terminal block on the shield connecting element by tightening the screws (5).

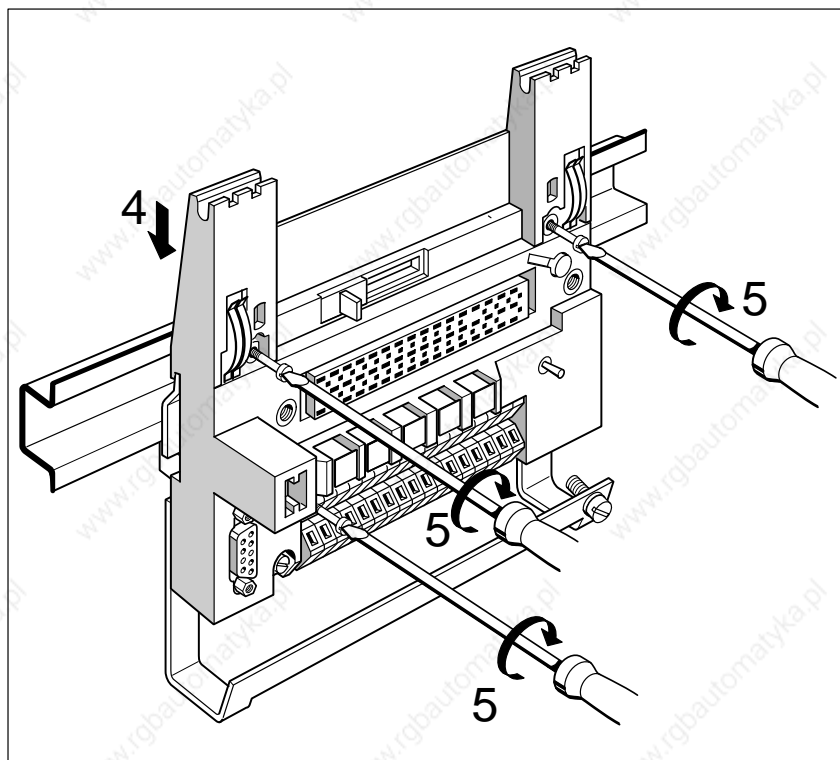

Figure 3-4 Mounting the Terminal Block on the Shield Connecting Element

### Setting the Coding Slide Switch

In order to prevent the wrong electronics block being plugged in, the terminal block has a coding slide switch (see Section 2.1, Figure 2-1, **1**).

The coding switch can be engaged in 6 settings. Each setting is assigned to a module class of the ET 200B distributed I/O station:

Table 3-1 Assignment of the Electronics Blocks to the Coding Slide Switch

Setting	Module Class
1	24 V digital modules
2	24 V special modules
3	Analog modules
4	Reserved
5	Reserved
6	230 V digital modules

### Setting the Station Number

Any station number from 00 to 99 can be set using an object such as a screwdriver (see Section 2.1, Figure 2-1, **10**):

- Station numbers 3 to 99 are permissible when operating with the IM 308-B master interface.
- Station numbers 1 to 99 are permissible when operating with the IM 308-C master interface.

The station number becomes valid only after a STOP/RUN transition of the ET 200B slave station.

### Setting the Coding Plugs

In the case of analog modules, you can set the necessary defaults for analog value measurement or analog value output for each channel via coding plugs (see Section 2.1, Figure 2-2, **7**).

See Section 9 “Analog Modules” for a description of the possible settings and their meanings.

## Installing and Setting the Terminal Block, continued

### Changing the Fuse

The fuse in the terminal block is a protection against overcurrent of the sensor supply and the supply to the internal logic circuits. If the fuse blows, the internal logic circuits of the module receive no voltage.

Use only the following fuses for replacement purposes:

Table 3-2 Permissible Fuses in the Terminal Block

Terminal Block	Fuse
TB1/DC	Minature fuse TR5-T 1.6; 125 V
TB1-4/DC	Minature fuse TR5-T 1.6; 125 V
TB2/DC	Minature fuse TR5-T 2.5; 250 V
TB2-4/DC	Minature fuse TR5-T 2.5; 250 V
TB3/DC	Minature fuse TR5-T 1.6; 125 V
TB4/DC	Minature fuse TR5-T 2.5; 250 V
TB8 analog	Minature fuse TR5-T 1.6; 125 V
TB6/AC	Miniature fuse TR5-T 1; 250 V AC

Proceed as follows when changing the fuse:

1. Switch the STOP/RUN switch to the “STOP” position.
2. Pull the electronics block off the terminal block.
3. Lever the fuse out of its base using a screwdriver.
4. Insert the new fuse.
5. Attach the electronics block to the terminal block.
6. Switch the RUN/STOP switch to “RUN”.

---

### Note

The TB6/AC terminal block has no STOP/RUN switch. Make sure that the external power supply is switched off before removing the electronics block and changing the fuse.

---

## 3.2 Installing the Electronics Block

### Hanging the Electronics Block on the Terminal Block

After having coded the terminal block via the coding slide switch, you can hang the electronics block on the terminal block:



#### Warning

Avoid electrical destruction of the electronics block.

The electronics block may only be hung onto the terminal block when the STOP/RUN switch of the terminal block is in the “STOP” position!

The TB6/DC terminal block has no STOP/RUN switch. Always switch off the external power supply before attempting to hang an electronics block (120/230 V AC) onto the TB6/DC.

1. Hang the electronics block on the terminal block (1).
2. Press the electronics block onto the terminal block (2).
3. Secure the electronics block by tightening the screws (3).

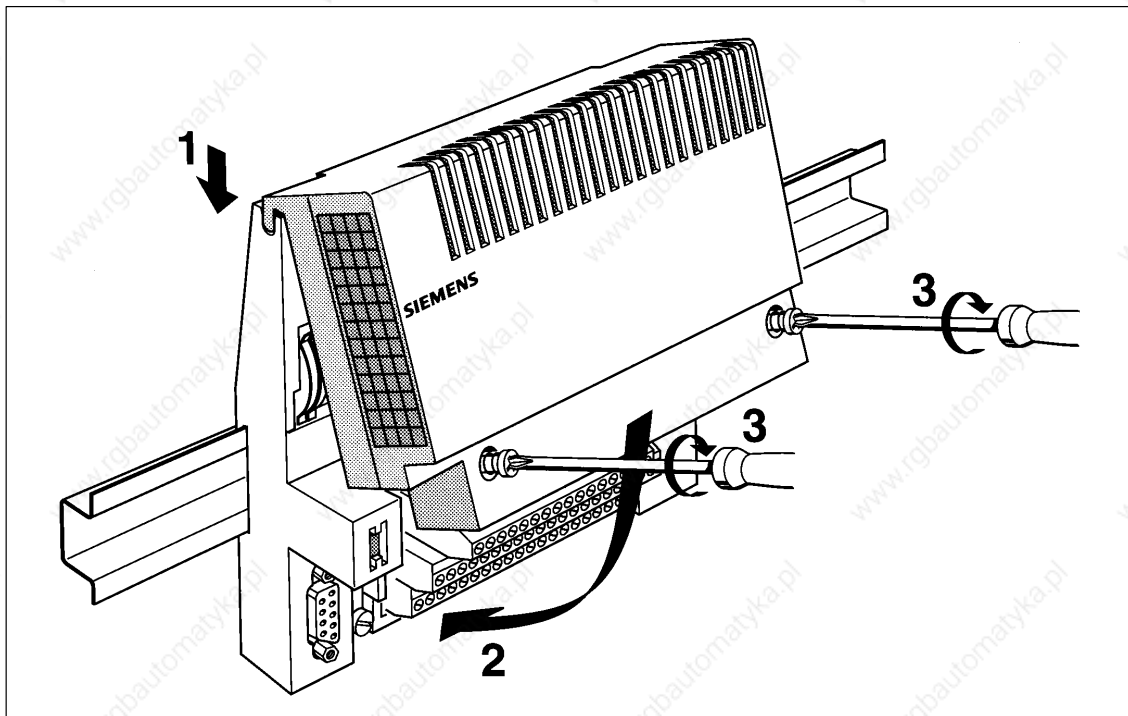

Figure 3-5 Hanging the Electronics Block on the Terminal Block

## Installing the Electronics Block, continued

### Labelling the Electronics Block

A labelling strip is inserted in the electronics block.

Individual DIN A4 sheets consisting of several labelling strips can be additionally ordered. Please refer to **Catalog ST 54.2** for order numbers.

#### Versions:

- For electronics blocks with 16DI, 16DQ, 8DI/8DO, 8RO:  
10 labelling strips on one DIN A4 sheet
- For electronics blocks with 16DI-AC, 16DO-AC, 32 DI, 16DO/2A, 32DO, 24DI/8DO, 16RO-AC, 8DI/8RO-AC:  
7 large labelling strips and 9 small labelling strips on one DIN A4 sheet.

### 3.3 Dismantling the Terminal Block and the Electronics Block

#### Dismantling (from the Standard Sectional Rail)

Proceed according to the following steps:

1. Remove the electronics block in the reverse sequence to that described in Figure 3-5.
2. Press the slide (1) on the bottom of the terminal block down using a screwdriver and
3. Swing the terminal block out of the standard sectional rail (2).

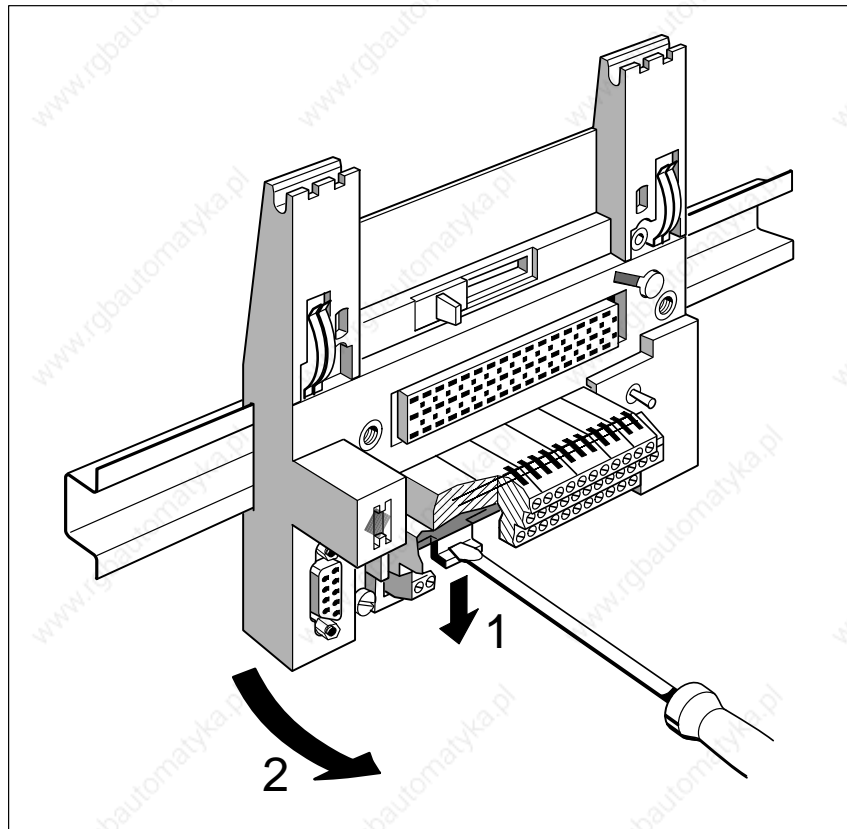

Figure 3-6 Dismantling the ET 200B

#### Dismantling (from the Shield Connecting Element)

Proceed according to the following steps:

1. Remove the electronics block in the reverse sequence to that described in Figure 3-5.
2. Remove the terminal block and the shield connecting element in the reverse sequence to that described in Figures 3-3 and 3-4.

## 3.4 Electrical Installation

### Introduction

The ET 200B distributed I/O station allows both **grounded and ungrounded** configurations.

### The Following Chapters

The following two chapters explain the configuration rules and give circuit examples for

- Grounded configuration
- Ungrounded configuration

The text contains numbers referring to their counterparts in the associated figures.

### 3.4.1 Grounded Configuration

#### Definition

In a grounded configuration, the reference potential of the ET 200B logic circuits and the protective ground conductor (PE) are connected to each other galvanically.

#### Rules

You must note the following points for a grounded configuration:

- You must provide a main switch (1) in accordance with DIN VDE 0100 for the ET 200B modules, the signal sensors and the actuators.
- If the spur lines are a maximum of 3 m long and are ground-fault-resistant and short-circuit-proof, the supply connection for the ET 200B and the load circuit requires no additional fuse (2).
- Use a Siemens load power supply unit (3) in the 6EV1 series (**Catalog ET 1**) for supplying the 24 V DC to the ET 200B.

If you connect another load power supply unit (24 V DC), please note that the voltage must be in the range 20 to 30 V (including ripple). The load power supply unit must generate a functional low voltage with safe electrical isolation in accordance with DIN VDE 0106. In the case of non-stabilized load power supply units, you require a back-up capacitor (rating 200  $\mu$ F per 1 A load current).

- Provide a detachable connection to the protective ground conductor (4) in the secondary circuit of the load power supply unit (M terminal).
- A fuse (5) is required for fusing the supply voltage.
- For both grounded and ungrounded configurations, the PE terminal  of the ET 200B must have a low-impedance connection to the protective ground conductor or the cabinet ground (machine parts) (6).
- Use a minimum cross-section of 4 mm<sup>2</sup> and a maximum of 10 mm<sup>2</sup> for equipotential bonding and ground connections.
- All machine parts must be grounded.



## Grounded Configuration, continued

### Connecting the Reference Potential of the Logic Circuits to PE

For a grounded configuration, you must also do the following at the digital terminal blocks:

1. Connect the PE terminal to the lower screw.
2. Tighten the upper screw. The upper screw connects the ground potential to PE.

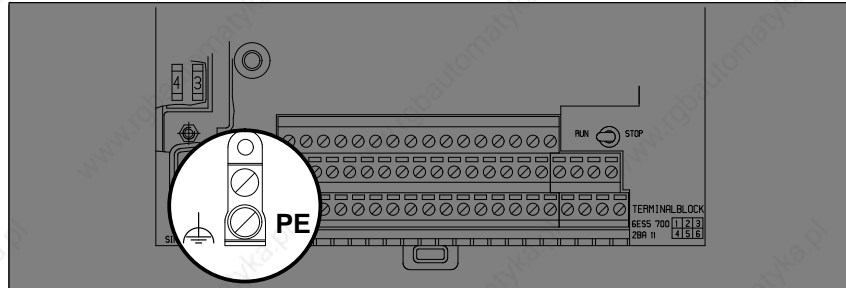

Figure 3-7 Both Screws Tightened in a Grounded Configuration

### Electrical Configuration

Figure 3-8 shows the grounded configuration for 24 V DC digital modules of the ET 200B:

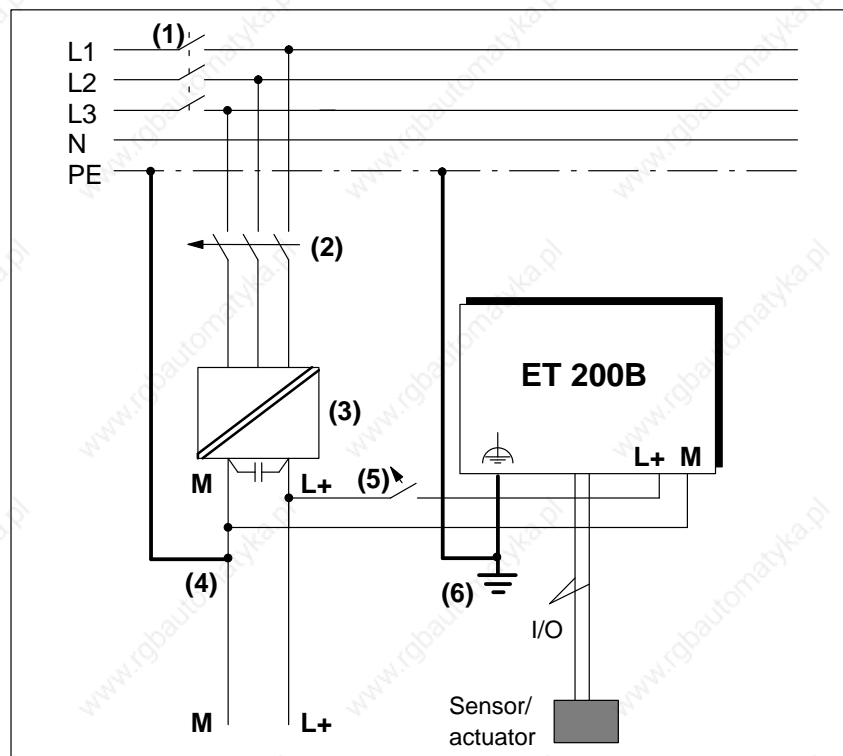

Figure 3-8 Grounded Configuration for 24 V DC Digital Modules of the ET 200B

**Electrical Configuration, continued**

Fig. 3-9 shows the grounded configuration for 120/230 V AC digital modules of the ET 200B:

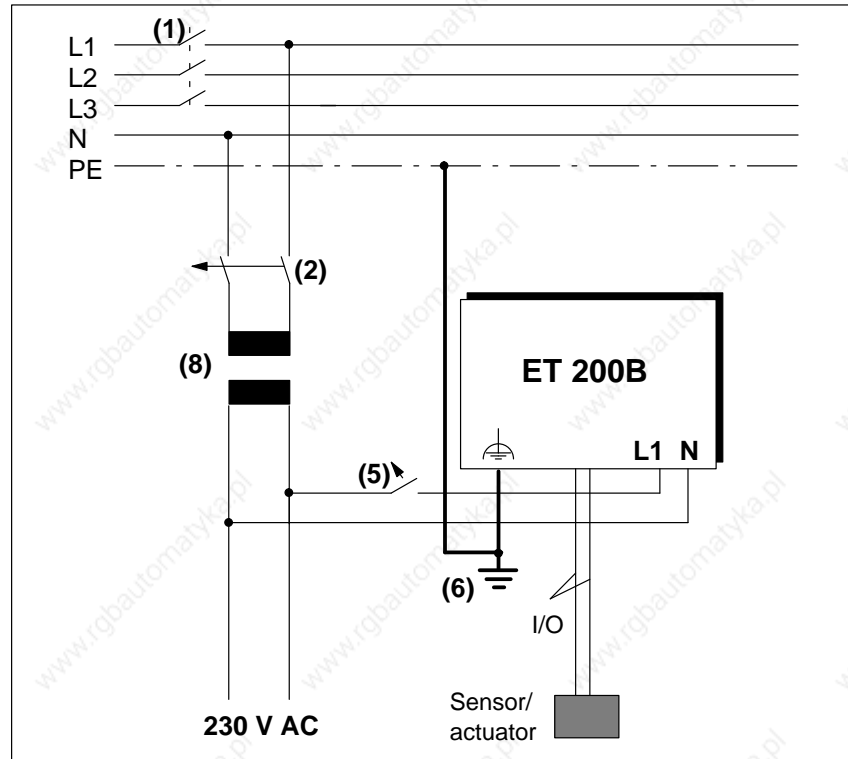

Figure 3-9 Grounded Configuration for 120/230 V AC Digital Modules of the ET 200B

### 3.4.2 Ungrounded Configuration

**Definition** In an ungrounded configuration, there is no galvanic connection between the reference potential of the ET 200B logic circuits and the protective ground conductor (PE).

**Rules** You must note the following points for an ungrounded configuration:

- You must provide a main switch **(1)** in accordance with DIN VDE 0100 for the ET 200B modules, the signal sensors and the actuators.
- If the spur lines are a maximum of 3 m long and are ground-fault-resistant and short-circuit-proof, the supply connection for the ET 200B and the load circuit requires no additional fuse **(2)**.
- Use a Siemens load power supply unit **(3)** in the 6EV1 series (**Catalog ET 1**) for supplying the 24 V DC to the ET 200B.

If you connect another load power supply unit (24 V DC), please note that the voltage must be in the range 20 to 30 V (including ripple). The load power supply unit must generate a functional low voltage with safe electrical isolation in accordance with DIN VDE 0106. In the case of non-stabilized load power supply units, you require a back-up capacitor (rating 200  $\mu$ F per 1 A load current).

- A fuse **(5)** is required for fusing the supply voltage.
- For both grounded and ungrounded configurations, the PE terminal  of the ET 200B must have a low-impedance connection to the protective ground conductor or the cabinet ground (machine parts) (core cross-section of PE min. 4 mm<sup>2</sup> and max. 10 mm<sup>2</sup>) **(6)**.
- Provide an insulation monitoring circuit against ground with voltage limitation in accordance with the regulations applying to the system, for example DIN VDE 0160 **(7)**.



#### Warning

The ungrounded configuration can be cancelled out by grounded machine parts and grounded electrical equipment.

**Example:** A grounded sensor or a grounded actuator connects the PE to the reference potential (M terminal) of the controller.

---

**Disconnecting the Reference Potential of the Logic Circuits from PE**

For an ungrounded configuration, you must also do the following at the digital terminal blocks:

1. Connect the PE terminal to the lower screw.
2. Remove the upper screw for an ungrounded configuration.

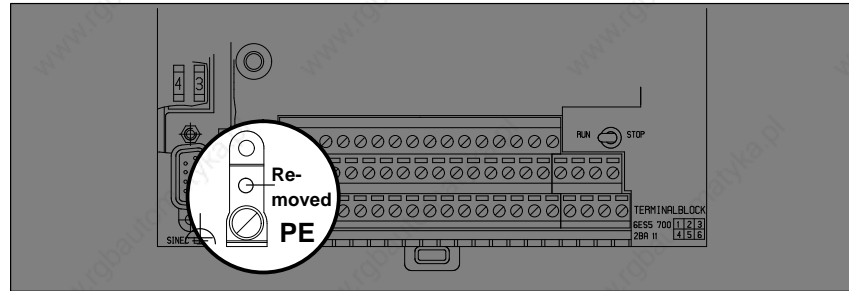

Figure 3-10 Upper Screw Removed in an Ungrounded Configuration

**Electrical Configuration**

Figure 3-11 shows the ungrounded configuration for 24 V DC digital modules of the ET 200B:

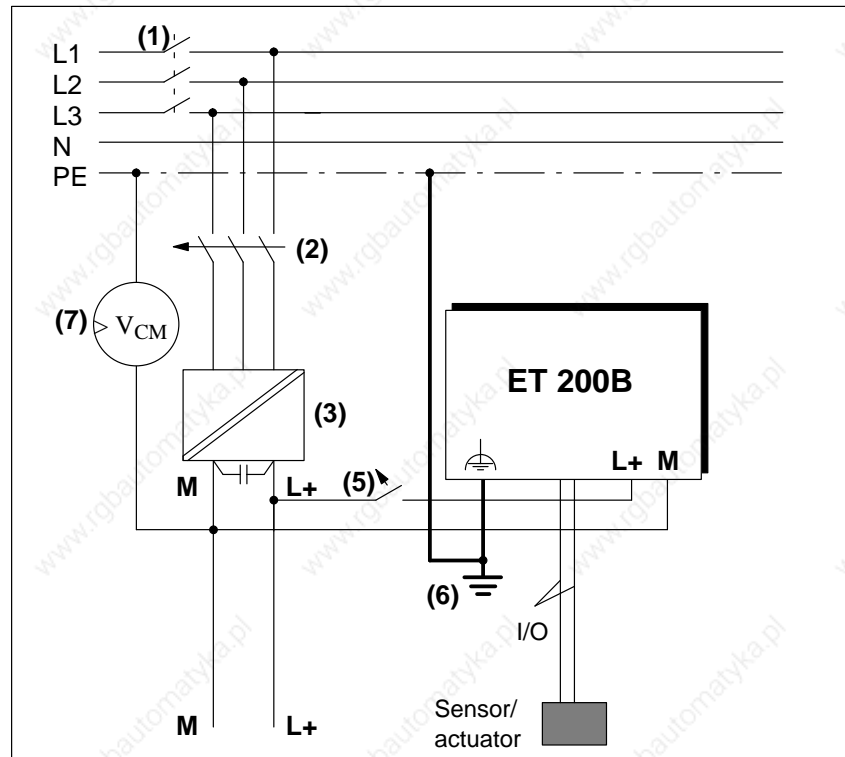

Figure 3-11 Ungrounded Configuration for 24 V DC Digital Modules of the ET 200 B

## 3.5 Wiring the Terminal Block

### Introduction

Connect the following to the terminal block:

- Supply voltage for internal logic circuits
- Sensor supply for input channels
- Load voltage supply for output channels
- Sensors/loads

### Wiring

The wiring of the terminal block is dependent on the electronics block used.

A distinction is made between **floating** and **non-floating electronics blocks**.

### Floating Electronics Block

In floating electronics blocks, the internal logic circuits and the load current circuit are galvanically isolated from each other.

Floating electronics blocks include:

- All analog electronics blocks
- All 120/230 V AC electronics blocks
- Floating 24 V DC electronics blocks.

---

### Note

You can use floating electronics blocks regardless of whether the reference potential of the supply voltage for the internal logic circuits is grounded or not.

---

### Non-Floating Electronics Blocks

In non-floating electronics blocks, the internal logic circuits and the load current circuit share a common reference potential (M ground).

Non-floating electronics blocks include:

- Non-floating 24 V DC electronics blocks.

## Pin Assignments

In Chapter 8 “Range of Modules”, you will find the pin assignments of each electronics block. Table 3-3 will help you.

Table 3-3 Pin Assignments of the Terminal Block

Pin Assignments of the ...	For Electronics Block ...	Described in ...
TB1/DC, TB1-4/DC and TB3/DC	ET 200B-16DI	Table 8-3
	ET 200B-16DO	Table 8-5
	ET 200B-8DI/8DO	Table 8-9
	ET 200B-8RO	Table 8-8
TB2/DC, TB2-4/DC and TB4/DC	ET 200B-16DO/2A	Table 8-6
	ET 200B-32DI, ET 200B-32DI 0.2ms	Table 8-4
	ET 200B-32DO	Table 8-7
	ET 200B-24DI/8DO, ET 200B-24DI/8DO 0.2ms	Table 8-10
TB6/AC	ET 200B-16DI-AC	Table 8-11
	ET 200B-16DO-AC	Table 8-12
	ET 200B-16RO-AC	Table 8-13
	ET 200B-8DI/8RO-AC	Table 8-14
TB8 analog	ET 200B-4/8DI	Table 9-14
	ET 200B-4AI	Table 9-26
	ET 200B-4AO	Table 9-31

## Wire Cross-Section

The following cross-sections are permissible for all power and signal lines:

- Line **with** connector sleeve: max. 1.5 mm<sup>2</sup>
- Line **without** connector sleeve: max. 2.5 mm<sup>2</sup>  
(min 0.08 mm<sup>2</sup> for TB3, TB4, TB8)  
(min 0.14 mm<sup>2</sup> for TB1, TB1-4,  
TB2, TB2-4)

Use the following cross-section for the protective ground conductor PE to the terminal block of the TB1-4/DC or the TB2-4/DC:

- Line **with** connector sleeve: max. 2.5 mm<sup>2</sup>.

## Wiring the Terminal Block, continued

### Connections

The wires are secured either in screw connections or spring-loaded connections, depending on the terminal block (see Fig. 3-12).

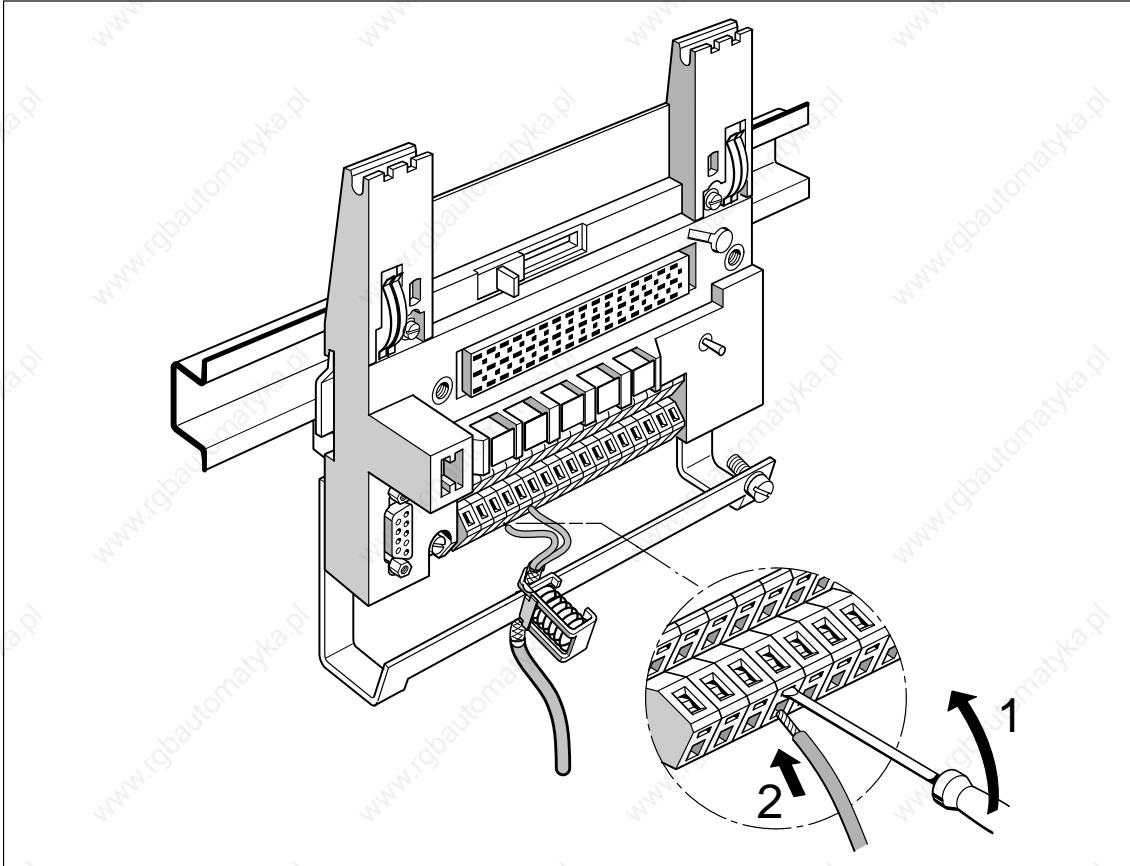

Figure 3-12 Securing the Wire in a Spring-Loaded Connection

## Shielding for Analog Value Processing

For analog value processing, connect the cable shields of the signal lines directly at the TB8 to the shield connecting element (Order No.: 6ES7 193-0CD40-7XA0).

### How to Proceed when Applying the Shielding

Follow the steps listed below:

1. Hang the TB8 terminal block on the shield connecting element after first mounting the shield connecting element on the standard sectional rail or a smooth surface (wall) (see Section 3.1).
2. Mount metallic terminal elements (see Section 3.1) on the bottom edge of the shield connecting element (**1** and **2**).
3. Strip the insulation of the signal lines.
4. Secure the bare cable ends to the terminal elements (**3** and **4**).
5. Connect the shield connecting element to the protective ground conductor (PE). The cross-section of PE must be a minimum of 4 mm<sup>2</sup> and a maximum of 10 mm<sup>2</sup>.
6. Connect the shield of the bus cable in such a way that the maximum bend radius when bent once ( $10 \times d_O$ ;  $d_O$  = outer diameter of the cable) is not exceeded.

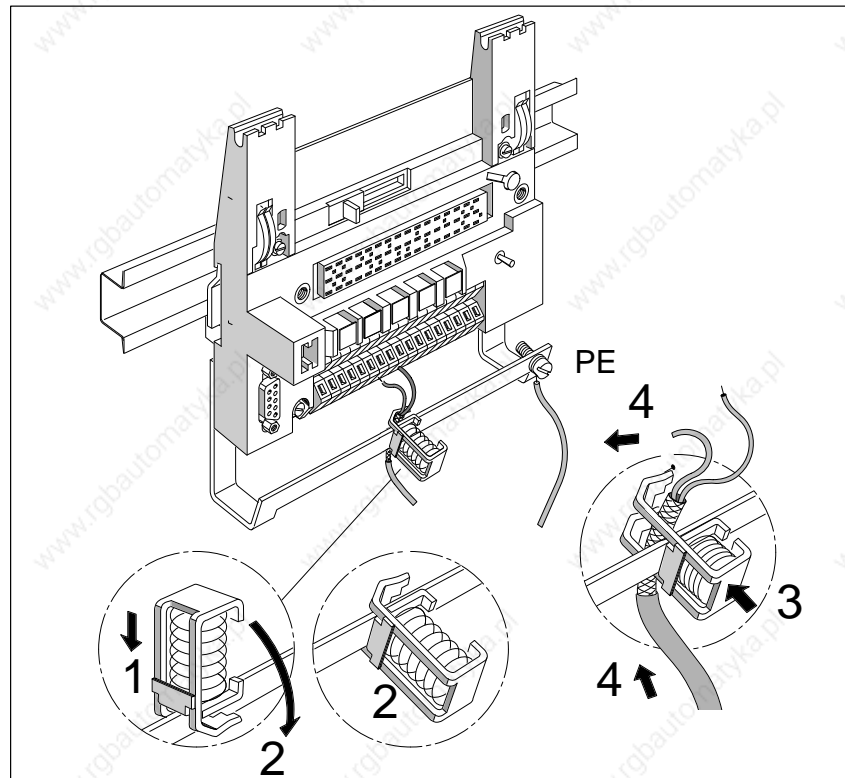

Figure 3-13 Shield Connecting Element on Terminal Block TB8



## 3.6 Wiring the Bus Interface

### Bus Interface

The SINEC L2-DP bus is connected via bus connectors.

### Bus Connectors

There are bus connectors in various installation sizes available for the ET 200B.

The previous SINEC L2 bus connectors (Order No.: 6ES5 ...) exceeded the installation height of the ET 200B. For this reason, new SINEC L2 bus connectors have been developed which **do not** exceed the installation height of the ET 200B when plugged in (Order No.: 6ES7 ...).

You can find the precise installation heights of the different SINEC L2 bus connectors in the Dimension Drawings in Section 8.1.1.

For the ET 200B, use one of the following SINEC L2 bus connectors with degree of protection IP 20:

Table 3-4 SINEC L2 Bus Connectors

Version	Order No.
Without programmer port	6ES7 972-0BA00-0XA0
With programmer port	6ES7 972-0BB00-0XA0
Without programmer port	6ES5 762-2AA12
With programmer port	6ES5 762-2AA21

# Address Assignment and Parameterization with COM ET 200

# 4

## Fundamentals

This chapter is based on the *ET 200 Distributed I/O System* manual.

The fundamentals of COM ET 200 are described in the *ET 200 Distributed I/O System* manual.

Address assignment is an important component of COM ET 200. The *ET 200 Distributed I/O System* manual contains useful information about the address assignment methods (linear and dual-port RAM addressing).

## In this Chapter

In this chapter, you will learn how to use the “CONFIGURING” screen form of the **COM ET 200** software package **V4.x** to configure and parameterize the ET 200B distributed I/O station.

You can define the following for each ET 200B slave station with this mask:

- The station number (see Section 4.1.1)
- The address range and the type of the station (see Section 4.1.2)
- The addresses of the inputs and outputs (see Section 4.1.3)
- The parameters for analog modules (see Section 4.2).

## COM ET 200 WINDOWS

If you are operating the ET 200B with **COM ET 200 WINDOWS**, you do not need to study this chapter.

The simple procedure for configuring and parameterizing slave stations with COM ET 200 WINDOWS is identical for all the ET 200 slaves and is not described in this manual. Please refer to the *ET 200 Distributed I/O System* manual (Order No. 6ES5 998-3ES12) for further details about how to use COM ET 200 WINDOWS.

COM ET 200 WINDOWS also provides extensive support for starting up the ET 200B modules through its integrated help system.

Chapter 9 “Analog Modules” lists all the parameters which you can set for the analog modules of the ET 200B with COM ET 200 WINDOWS.

## 4.1 Address Assignment with COM ET 200 V4.x

### In this Section

In this section, you will learn how to use the “CONFIGURING” screen form of the COM ET 200 software package V4.x to configure the ET 200B distributed I/O station.

### Type Files

To start up an ET 200B with COM ET 200 V4.x, you must ensure that the type file of the ET 200B module has been installed in the COM ET 200 directory. The type files have the following designations:

Table 4-1 Designation of the Type Files for the ET 200B

Station Type		Order Number	Type File
B-16DI	DP	6ES7 131-0BH00-0XB0	SI0001TD.200
B-32DI	DP	6ES7 131-0BL00-0XB0	SI0004TD.200
B-32DI.2	DP	6ES7 131-0BL10-0XB0	SI000CTD.200
B-16DO	DP	6ES7 132-0BH00-0XB0	SI0002TD.200
B-16DO/2A	DP	6ES7 132-0BH10-0XB0	SI0005TD.200
B-32DO	DP	6ES7 132-0BL00-0XB0	SI000DTD.200
B-8DI/8DO	DP	6ES7 133-0BH00-0XB0	SI000BTD.200
B-24DI/8DO	DP	6ES7 133-0BN00-0XB0	SI000FTD.200
B-24DI/8DO.2	DP	6ES7 133-0BN10-0XB0	SI000ETD.200
B-16DI-AC	DP	6ES7 131-0HF00-0XB0	SI0019TD.200
B-16DO-AC	DP	6ES7 132-0HF00-0XB0	SI001ATD.200
B-16RO-AC	DP	6ES7 132-0HH00-0XB0	SI001CTD.200
B-8DI/8RO-AC	DP	6ES7 133-0HH00-0XB0	SI001DTD.200
B-8RO	DP	6ES7 132-0GF00-0XB0	SI0003TD.200
B-4/8AI	DP	6ES7 134-0KH00-0XB0	SI801ATD.200
B-4AI	DP	6ES7 134-0HF00-0XB0	SI8019TD.200
B-4AO	DP	6ES7 135-0HF00-0XB0	SI8018TD.200

### Availability of Type Files

All the type files are made available centrally in the Interface Center, from where you can pick them up by modem under the following mailbox number:

Tel.: (Germany) 0911/73-7972

The contents of the type files are reproduced in Appendix A of this manual. If any of the files are missing, you can thus create them yourself if necessary using an ASCII editor.

**Installing the Type Files**

Copy the files into the COM ET 200 directory as follows:

**Installation under S5-DOS/ST (MS-DOS):**

Copy the type files into the COM ET 200 directory with

**PCOPY 0A:\*.\*200 C:\COMET200**

**Installation under S5-DOS/ST (PCP/M):**

Copy the type files into the user area of the programmer containing COM ET 200 with

**PIP C:=A:\*.\*200[g0rvw**

### 4.1.1 Entering the Station Number

#### Starting Point

You have edited the ET 200 system parameters in the “ET 200 SYSTEM PARAMETERS” screen form of COM ET 200 (see *ET 200 Distributed I/O System* manual).

#### Rules

Please note the following when editing the station number:

- An ET 200B station must have a station number in the range 3 to 99. (Only two-digit station numbers can be set on the ET 200B slave station.)

#### How to Proceed When Entering the Station Number

To enter the station number, execute the following steps:

1. Press <F2> in the “FUNCTIONS” screen form to branch to the “CONFIGURING” screen form.
2. Correct the station number here if necessary.

#### Valid Entries:

Possible station numbers for ET 200B: 3 to 99

#### Help:

Press <F7> (HELP) to see a window with all previously assigned station numbers and station types. You can select a station and display its configuration. If no station numbers have yet been assigned, the message “No stations configured” appears.

3. Confirm the entry with <F6> (ENTER).

#### Result

If the station whose number you have entered has already been configured, the configuration appears on the screen after you have made your entry.

If the station has not yet been configured, two further input fields appear in the “CONFIGURING” screen form. These are “Area” and “Station type” (see Section 4.1.2).

**Example**

In our example, we assign the station number “5” to the station

Program file selected: TEST@@ET.200					SIMATIC S5 / COM ET 200		
CONFIGURING							
Station number: 5							
<b>F1</b>	<b>F2</b>	<b>F3</b>	<b>F4</b>	<b>F5</b>	<b>F6</b>	<b>F7</b>	<b>F8</b>
					ENTER	HELP	EXIT

Figure 4-1 “CONFIGURING” Screen Form (1)

## 4.1.2 Entering the Address Area and the Station Type

### Starting Point

If the station has not yet been configured, two further input fields appear in the “CONFIGURING” screen form after the station number has been confirmed. These are “Area” and “Station type” (see Section 4.1.1).

### How to Proceed When Entering the Address Area and the Station Type

Execute the following steps to define the address area and the station type of the ET 200B:

1. Enter the address area of the station in the “Area” input field.

#### Valid Entries:

If you have set the ET 200 system parameter “Dual-port RAM addressing”(paging) with a default of “Y” (yes), enter the abbreviation of the I/O area with the page number here (example: “P3” for page no. 3 in the P area).

If you have set the ET 200 system parameter “Dual-port RAM addressing” (paging) with a default of “N” (no), enter one of the permissible areas here (P or Q for linear addressing).

#### Fundamentals:

The fundamentals of addressing for the ET 200 (linear addressing or dual-port RAM addressing (paging)) are described in the *ET 200 Distributed I/O System* manual.

2. Enter the relevant designation for your ET 200B station in the “Station type” input field.

#### Help:

Press <F7> (HELP) to see a window showing all the station types you can enter in the input field.

If the desired station does not appear, check to see if the relevant type file is located in a directory known to COM ET 200 (see Table 4-1).

3. Confirm the entry with <F6> (ENTER).

### Result

After the entries have been made, further input fields appear for configuring the inputs and outputs in the “CONFIGURING” screen form (see Section 4.1.3).





### 4.1.3 Entering the Station Name, Addresses and Address ID

**Starting Point** After entering the station type (see Section 4.1.2), further input fields appear for configuring the inputs and outputs in the “CONFIGURING” screen form.

**“Station Name”** If desired, you can enter a name for the ET 200B distributed I/O station in the “Station name” input field (all keyboard characters permissible).

**“Next Available Address”** COM ET 200 automatically displays the “Next available address” for digital inputs (DIs), digital outputs (DOs), analog inputs (AIs) and analog outputs (AOs).

When the “CONFIGURING” screen form is called for the first time in the selected program file, the next available addresses are set to “0”.

**How to Proceed When Entering Addresses and Address IDs** Execute the following steps to define the addresses and the address ID of the ET 200B:

1. If desired, enter another **available** address which you want to use for the inputs or outputs of the ET 200B in the input fields “Next available address”.

**Valid Entries:**

In the case of linear addressing: 0 ... 255

In the case of dual-port RAM addressing in the Q area: 0 ... 254

In the case of dual-port RAM addressing in the P area: 192 ... 254

2. Enter the address IDs of the ET 200B in the input fields in the “Configuration area” (Figure 4-3 : )

---

**Note**

Enter the details for **one** ET 200B station per “CONFIGURING” screen form.

Analog ET 200B modules always have the slot “0.”. In the case of digital ET 200B modules, all output ports have the slot “0.”. All input ports have slot “1.”.

---

**Valid Entries:**

You can see from Table 4-2 how to enter the address IDs:

**Precondition:**

The cursor must be on the input field for the address ID.

3. Confirm the entries with <F6> (ENTER).

**Result**

COM ET 200 automatically displays the area starting address in the output field “Area address: I: O:”

- In field “I:”, the area starting address for the inputs
- In field “O:”, the area starting address for the outputs

**Address IDs**

The following address IDs are valid for the ET 200B:

Table 4-2 Address IDs for ET 200B

Module	Order Number	Address ID		Consistency	Address Range (Bytes)		Address Area
		Slot 0	Slot 1		I	O	
ET 200B-16DI	6ES7 131-0BH00-0XB0	000	017	Byte	2	–	Digital
ET 200B-32DI	6ES7 131-0BL00-0XB0	000	019	Byte	4	–	Digital
ET 200B-32DI 0.2ms	6ES7 131-0BL10-0XB0						
ET 200B-16DO	6ES7 132-0BH00-0XB0	033	000	Byte	–	2	Digital
ET 200B-16DO/2A	6ES7 132-0BH10-0XB0	033	000	Byte	–	2	Digital
ET 200B-32DO	6ES7 132-0BL00-0XB0	035	000	Byte	–	4	Digital
ET 200B-8DI/8DO	6ES7 133-0BH00-0XB0	8DA or 032	8DE or 016	Byte	1	1	Digital
ET 200B-24DI/8DO	6ES7 133-0BN00-0XB0	8DA or 032	018	Byte	3	1	Digital
ET 200B-24DI/8DO 0.2ms	6ES7 133-0BN10-0XB0						
ET 200B-8RO	6ES7 132-0GF00-0XB0	032	000	Byte	–	1	Digital
ET 200B-16DI-AC	6ES7 131-0HF00-0XB0	000	017	Byte	2	–	Digital
ET 200B-16DO-AC	6ES7 132-0HF00-0XB0	033	000	Byte	–	2	Digital
ET 200B-16RO-AC	6ES7 132-0HH00-0XB0	033	000	Byte	–	2	Digital
ET 200B-8DI/8RO-AC	6ES7 133-0HH00-0XB0	8DA or 032	8DE or 016	Byte	1	1	Digital
ET 200B-4/8AI	6ES7 134-0KH00-0XB0	087	–	Word	16	–	Analog
ET 200B-4AI	6ES7 134-0HF00-0XB0	4AE or 083	–	Word	8	–	Analog
ET 200B-4AO	6ES7 135-0HF00-0XB0	099	–	Word	–	8	Analog

## Entering the Station Name, Addresses and Address IDs, continued

### Example

In our example, the ET 200B-24DI/8DO is to be used for a “press control”.

#### Addresses:

24 digital inputs: I 0.0 to 0.7, I 1.0 to 1.7, I 2.0 to 2.7

8 digital outputs: O 0.0 to 0.7

#### Address IDs:

24 digital inputs: 018

8 digital outputs: 032

Program file selected: TEST@ET.200 SIMATIC S5 / COM ET 200  
**CONFIGURING**

---

Station number: 5      Area: P      Station type: B-24DI/8DO DP  
 Station name:   
 Next available address: DI:  DO:  AI:  AO:

Configuration: Area address I: O:  
 (Shift F6: DP slave parameterizat on frame)

0.	1.	2.	3.	4.	5.	6.	7.
<input type="text" value="032"/>	<input type="text" value="018"/>	<input type="text"/>	<input type="text"/>	<input type="text"/>	<input type="text"/>	<input type="text"/>	<input type="text"/>
8.	9.	10.	11.	12.	13.	14.	15.
<input type="text"/>	<input type="text"/>	<input type="text"/>	<input type="text"/>	<input type="text"/>	<input type="text"/>	<input type="text"/>	<input type="text"/>
16.	17.	18.	19.	20.	21.	22.	23.
<input type="text"/>	<input type="text"/>	<input type="text"/>	<input type="text"/>	<input type="text"/>	<input type="text"/>	<input type="text"/>	<input type="text"/>
24.	25.	26.	27.	28.	29.	30.	31.
<input type="text"/>	<input type="text"/>	<input type="text"/>	<input type="text"/>	<input type="text"/>	<input type="text"/>	<input type="text"/>	<input type="text"/>

<b>F1</b>	<b>F2</b>	<b>F3</b>	<b>F4</b>	<b>F5</b>	<b>F6</b>	<b>F7</b>	<b>F8</b>
STATION +	STATION -	DELETE STATION	NEW STATION	ADDRESS ASSIGN.	ENTER	HELP	EXIT

Figure 4-3 “CONFIGURING” Screen Form (3)

## Entering the Address IDs Individually

You can find all the address IDs you require for the ET 200B in Table 4-2.

If the address IDs are not available to you, you can have COM ET 200 generate them for you. For this purpose, you must fill out the “DP Identifier” window.

### Example

This example shows how to enter the address ID for ET 200B-24DI/8DO:

1. Position the cursor at the input field for slot “0.”.
2. Press <F7> (HELP).

The “DP Identifier” window appears:

```

DP Identifier -----
I/O: # Length: ## Format: # Consistency: #
Help: -----
I/O:      I: Input,           O: Output,
          X: Input/output,
Length:   1 - 16
Format:   B: Byte,           W: Word,
Consistency: 0: Byte/Word    1: Total
          (depending on format)
  
```

3. Fill out the 4 input fields with the help of the legend.

“DP Identifier” window for the 8 outputs of the ET 200B-24DI/8DO (slot “0.”):

```

DP Identifier -----
I/O: 0 Length: 1 Format: B Consistency: 0
Help: -----
I/O:      I: Input,           O: Output,
          X: Input/output,
Length:   1 - 16
Format:   B: Byte,           W: Word,
Consistency: 0: Byte/Word    1: Total
          (depending on format)
  
```

4. Confirm the entries with <F6> (ENTER).
5. Position the cursor at the input field for slot “1.”.
6. Press <F7> (HELP) again.

The “DP Identifier” window appears again.

## Entering the Station Name, Addresses and Address IDs, continued

7. Fill out the 4 input fields for the 24 inputs too with the help of the legend.

“DP Identifier” window for the 24 inputs of the ET 200B-24DI/8DO (slot “1.”):

```
DP Identifier
-----
I/O: I Length: 3 Format: B Consistency: 0
Help:
-----
I/O:      I: Input,      O: Output,
          X: Input/output,
Length:   1 - 16
Format:   B: Byte,      W: Word,
Consistency: 0: Byte/Wort  1: Total
          (depending on format)
```

8. Confirm the entries with <F6> (ENTER).

### Result

The input fields for the address ID contain the correct address IDs for the ET 200B-24DI/8DO (see Figure 4-3):

032: for 8 outputs in slot “0.”

018: for 24 inputs in slot “1.”

## 4.2 Entering the Parameterization Frame with COM ET 200 V.4x

### Introduction

The diagnostics characteristics for the analog ET 200B modules and the necessary defaults for analog value measurement or analog value output are defined in the parameterization frame.

In the case of the digital ET 200B modules, settings cannot be made via the parameterization frame. When the “DP Slave Parameterization frame” window is selected, 5 bytes are pre-assigned with “00<sub>H</sub>”.

### Note

You are not allowed to overwrite the 5 bytes of the parameterization frames of the digital ET 200B modules which have been pre-assigned with “00<sub>H</sub>”.

### How to Proceed When Entering Parameters

Execute the following steps to enter the parameterization frame of the ET 200B:

1. Press (Shift) <F6> (DP Slave Parameterization Frame)

The “DP Slave Parameterization Frame” window appears with the default parameters for the ET 200B station.

#### Example:

Below is the pre-assigned parameterization frame for the ET 200B-4AI:

DP SLAVE PARAMETERIZATION FRAME										
Byte	(Input in KH format)									
0	13	00	00	00	00	00	00	19	19	19
10	19	00	00	00	00	00	00	00	00	06
20	FF	00	00	00	00					

2. Enter the parameters in “KH”. The figures and tables on the following pages explain the valid entries and their meanings.
3. Terminate entry of the parameterization frame with <F6> (ENTER).
4. Confirm the configuration with <F6> (ENTER).

### Result

The configuration is then stored in the default file.

COM ET 200 automatically ensures that areas that must be transferred consistently are also marked as consistent areas. This means that analog values, for example, are transferred in one frame (consistency over an area of 2 bytes).

### 4.2.1 Parameterizing the ET 200B-4/8AI (6ES7 134-0KH00-0XB0)

#### Pre-Assignment of the Parameterization Frame

When the “DP SLAVE PARAMETERIZATION FRAME” window is selected for the first time, the parameterization frame for the ET 200B-4/8AI is pre-assigned as follows:

DP SLAVE PARAMETERIZATION FRAME										
Byte   (Input in KH format)										
0	13	00	00	00	00	00	AA	14	14	14
10	14	00	00	00	00	00	00	00	00	06
20	FF	00	00	00	00					

#### Note

Only bytes 3, 4, 6 to 10 and 23 (marked in the figure with “□”) are relevant for parameterizing the function of the ET 200B-4/8AI.

All other bytes contain “00H” or COM ET 200-specific codes (“13H” in byte 0; “06H” in byte 19; “FFH” in byte 20), which you must not overwrite!

#### Structure of the Parameterization Frame, Byte 3

In byte 3, you define the diagnostics characteristics for the input channels of the ET 200B-4/8AI:

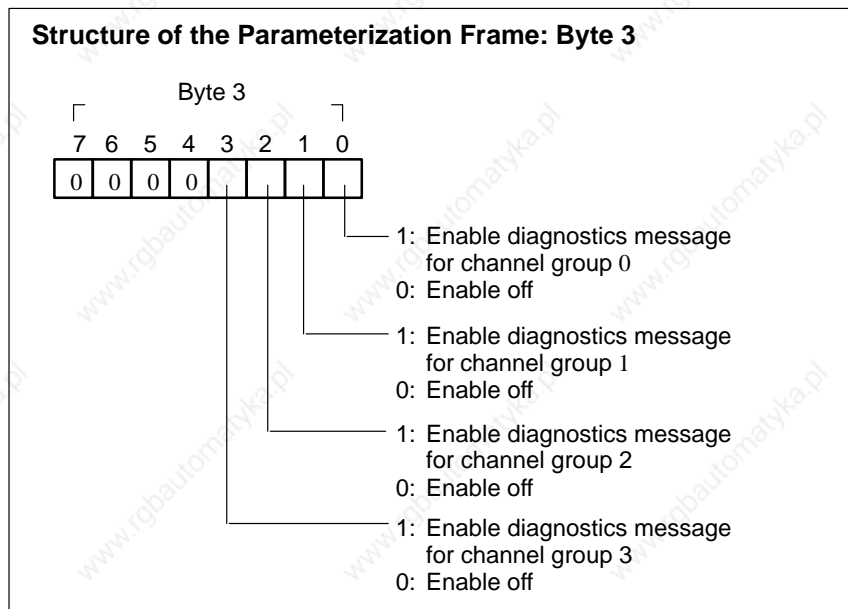

Figure 4-4 Structure of the Parameterization Frame of the ET 200B-4/8AI: Byte 3

### Structure of the Parameterization Frame, Byte 4

In byte 4, you define the response of the ET 200B-4/8AI to wire break:

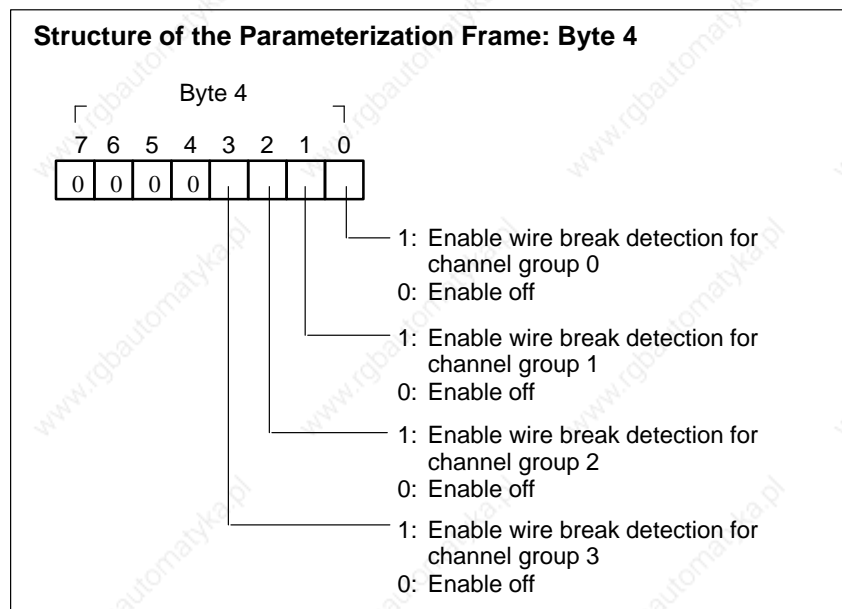

Figure 4-5 Structure of the Parameterization Frame of the ET 200B-4/8AI: Byte 4

#### Note

You can only parameterize wire break detection if the following sensors are connected:

- Thermocouple: type J, K, L
- Resistance thermometer: Pt 100
- Voltage sensor:  $\pm 80$  mV

In all other measured value ranges, you must assign byte 4 the value "00".



## Parameterizing the ET 200B-4/8AI (6ES7 134-0KH00-0XB0), continued

### Structure of the Parameterization Frame, Bytes 6 to 10

Table 4-3 contains the permissible entries for bytes 6 to 10 of the parameterization frame of the ET 200B-4/8AI.

Table 4-3 Parameters for the ET 200B-4/8AI (Bytes 6 to 10 of the Parameterization Frame)

Byte	Parameter	Explanation	Value Range	Hex Code
6	Integration time	Specify an optimal integration time of the A/D converter for the purpose of noise suppression.	20 ms 16.7 ms	AA <sub>H</sub> 55 <sub>H</sub>
7	Type and range of the measurement for channel group 0 (channels 0, 1) (terminals 0.1/0.2, 0.3/0.4)	Set the type and the range of the measurement according to the channel group.		
8	Type and range of the measurement for channel group 1 (channels 2, 3) (terminals 1.1/1.2, 1.3/1.4)	in the case of voltage measurement:	± 1 V ± 0.5 V ± 0.25 V ± 80 mV	14 <sub>H</sub> 13 <sub>H</sub> 12 <sub>H</sub> 11 <sub>H</sub>
9	Type and range of the measurement for channel group 2 (channels 4, 5) (terminals 2.1/2.2, 2.3/2.4)	in the case of resistance thermometer with linearization:	Pt 100 standard range	82 <sub>H</sub>
10	Type and range of the measurement for channel group 3 (channels 6, 7) (terminals 3.1/3.2, 3.3/3.4)	in the case of a thermocouple with external reference junction:	Type J with linearization Type K with linearization Type L with linearization	E5 <sub>H</sub> E8 <sub>H</sub> E6 <sub>H</sub>
23	Measured value representation		Two's complement Amount with sign	00 <sub>H</sub> 01 <sub>H</sub>

■ : Default in the parameterization frame

## 4.2.2 Parameterization of the ET 200B-4AI (6ES7 134-0HF00-0XB0)

### Pre-Assignment of the Parameterization Frame

When the “DP SLAVE PARAMETERIZATION FRAME” window is selected for the first time, the parameterization frame for the ET 200B-4AI is pre-assigned as follows:

DP SLAVE PARAMETERIZATION FRAME										
Byte   (Input in KH format)										
0	13	00	00	00	00	00	00	19	19	19
10	19	00	00	00	00	00	00	00	00	06
20	FF	00	00	00	00	00	00	00	00	00

### Note

Only bytes 3, 7 to 10 and 23 (marked in the figure with “□”) are relevant for parameterizing the function of the ET 200B-4AI.

All other bytes contain “00H” or COM ET 200-specific codes (“13H” in byte 0; “06H” in byte 19; “FFH” in byte 20), which you must not overwrite!

### Structure of the Parameterization Frame, Byte 3

In byte 3, you define the diagnostics characteristics for the input channels of the ET 200B-4AI:

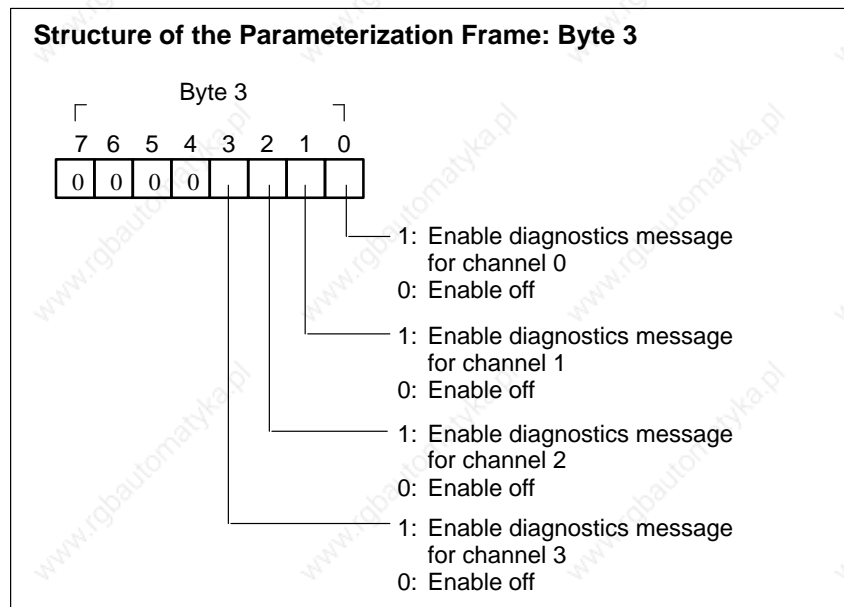

Figure 4-6 Structure of the Parameterization Frame of the ET 200B-4AI: Byte 3

## Parameterization of the ET 200B-4AI (6ES7 134-0HF00-0XB0), continued

### Structure of the Parameterization Frame, Bytes 7 to 10

Table 4-4 contains the permissible entries for bytes 7 to 10 of the parameterization frame of the ET 200B-4AI.

Table 4-4 Parameters for the ET 200B-4AI (Bytes 7 to 10 of the Parameterization Frame)

Byte	Parameter	Explanation	Value Range	Hex Code
7	Type and range of the measurement for channel 0 (terminals 0.1/0.2)	Set the type and the range of the measurement according to the channel.  in the case of voltage measurement:  in the case of current measurement:		
8	Type and range of the measurement for channel 1 (terminals 1.1/1.2)			
9	Type and range of the measurement for channel 2 (terminals 2.1/2.2)			
10	Type and range of the measurement for channel 3 (terminals 3.1/3.2)			
23	Measured value representation		Two's complement Amount with sign Binary	00 <sub>H</sub> 01 <sub>H</sub> 02 <sub>H</sub>

■ : Defaults in the parameterization frame

### 4.2.3 Parameterization of the ET 200B-4AO (6ES7 135-0HF00-0XB0)

#### Pre-Assignment of the Parameterization Frame

When the “DP SLAVE PARAMETERIZATION FRAME” window is selected for the first time, the parameterization frame for the ET 200B-4AO is pre-assigned as follows:

DP SLAVE PARAMETERIZATION FRAME										
Byte	(Input in KH format)									
0	13	00	00	00	00	00	00	19	19	19
10	19	00	00	00	00	00	00	00	00	06
20	FF	00	00	00	00	00	00	00	00	00

#### Note

Only bytes 3, 7 to 10 (marked in the figure with “□”) are relevant for parameterizing the function of the ET 200B-4AO.

All other bytes contain “00H” or COM ET 200-specific codes (“13H” in byte 0; “06H” in byte 19; “FFH” in byte 20), which you must not overwrite!

#### Structure of the Parameterization Frame, Byte 3

In byte 3, you define the diagnostics characteristics for the output channels of the ET 200B-4AO:

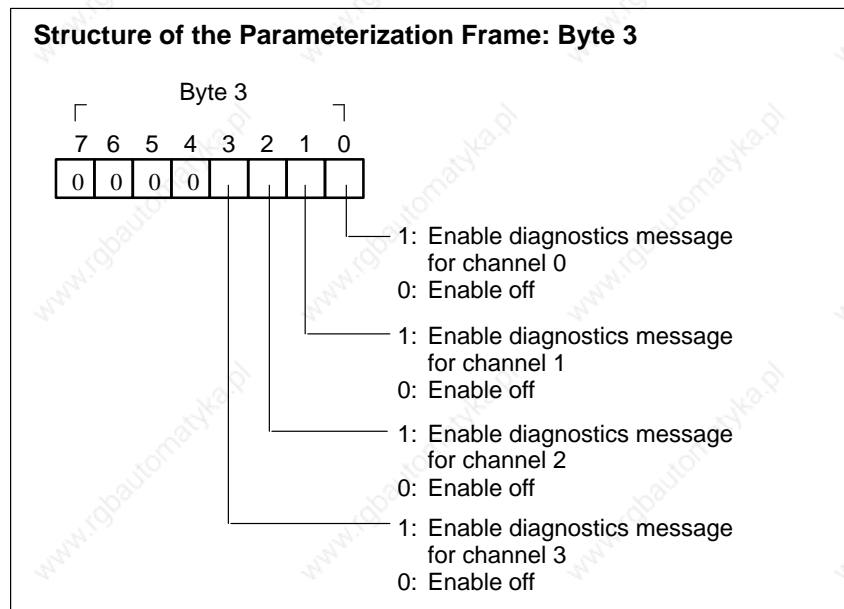

Figure 4-7 Structure of the Parameterization Frame of the ET 200B-4AO: Byte 3

## Parameterization of the ET200B-4AO (6ES7 135-0HF00-0XB0), continued

### Structure of the Parameterization Frame, Bytes 7 to 10

Table 4-5 contains the permissible entries for bytes 7 to 10 of the parameterization frame of the ET 200B-4AO.

Table 4-5 Parameters for the ET 200B-4AO (Bytes 7 to 10 of the Parameterization Frame)

Byte	Parameter	Explanation	Value Range	Hex Code
7	Type and range of the measurement for channel 0 (terminals 0.1/0.2)	Set the type and the range of the output according to the channel.  in the case of voltage output:  in the case of current output:		
8	Type and range of the measurement for channel 1 (terminals 1.1/1.2)			
9	Type and range of the measurement for channel 2 (terminals 2.1/2.2)			
10	Type and range of the measurement for channel 3 (terminals 3.1/3.2)			

■ : Defaults in the parameterization frame

#### 4.2.4 Structure of the Parameterization Frame in KH Format (Summary)

**Structure** The 25-byte parameterization frame has the following structure:

<b>Byte No.</b>	0	1	2	3	4	5	6	7	8	9	10	11 ... 18	19	20	21	22	23	24
<b>Contents in Hex</b>	13	00	00	xx	xx	00	xx	xx	xx	xx	xx	00	06	FF	00	00	xx	00

The bytes indicated with “xx” have the following meanings:

Table 4-6 Contents and Meaning of the Bytes

Byte	Structure	Code		
<b>03</b>	Enables diagnostics message for channel (group).			
	Bit 0 = channel (group) 0 Bit 1 = channel (group) 1 Bit 2 = channel (group) 2 Bit 3 = channel (group) 3	Bit at “1”: diagnostics message enabled Bit at “0”: diagnostics message not enabled (default)		
<b>04</b>	Enables wire break detection, only in the case of the ET 200B-4/8AI with selected value range Pt 100, thermocouple or voltage sensor $\pm 80$ mV			
	Bit 0 = channel group 0 Bit 1 = channel group 1 Bit 2 = channel group 2 Bit 3 = channel group 3	Bit at “1”: diagnostics message enabled Bit at “0”: diagnostics message not enabled (default) (In the event of a wire break, the overflow bit is also set.)	4/8AI	
<b>06</b>	Sets the integration time, only for ET 200B-4/8AI			
		AA <sub>H</sub> 55 <sub>H</sub>	Integration time 20 ms for 50 Hz supply (default) Integration time 16.7 ms for 60 Hz supply	4/8AI 4/8AI
<b>07, 08, 09, 10</b>	Sets the analog value range			
	Byte 7 = channel (group) 0	19 <sub>H</sub>	$\pm 10$ V	4AI, 4AO
	Byte 8 = channel (group) 1	18 <sub>H</sub>	0 to 10 V	4AO
	Byte 9 = channel (group) 2	16 <sub>H</sub>	$\pm 5$ V	4AI
	Byte 10 = channel (group) 3	15 <sub>H</sub>	$\pm 2.5$ V	4AI
		14 <sub>H</sub>	$\pm 1.25$ V, for ET 200B-4AI	4AI
		14 <sub>H</sub>	$\pm 1$ V, for ET 200B-4/8AI	4/8AI
		13 <sub>H</sub>	$\pm 0.5$ V	4/8AI
		12 <sub>H</sub>	$\pm 0.25$ V	4/8AI
		11 <sub>H</sub>	$\pm 80$ mV	4/8AI
		24 <sub>H</sub>	$\pm 20$ mA	4AI, 4AO
		22 <sub>H</sub>	0 to 20 mA	4AI, 4AO
		23 <sub>H</sub>	4 to 20 mA	4AI, 4AO
		82 <sub>H</sub>	Pt 100 standard	4/8AI
		E5 <sub>H</sub>	Thermocouple type J with linearization	4/8AI
		E8 <sub>H</sub>	Thermocouple type K with linearization	4/8AI
		E6 <sub>H</sub>	Thermocouple type L with linearization	4/8AI

**Parameterization of the ET200B-4A0 (6ES7 135-0HF00-0XB0), continued**

Table 4-6 Contents and Meaning of the Bytes, continued

Byte	Structure	Code		
23	Selects the measured value representation (ET 200B-4AI and ET 200B-4/8AI only)			
		00 <sub>H</sub>	Two's complement	4AI, 4/8AI
		01 <sub>H</sub>	Amount and sign	4AI, 4/8AI
		02 <sub>H</sub>	Binary	4AI

# Startup and Test with COM ET 200

# 5

## Startup Methods

There are two methods of starting up and testing the ET 200B distributed I/O station:

- Using the ET 200 Handheld (only ET 200B digital modules)
- Using COM ET 200 v 4.x and a programmer (with the CP 5410 S5-DOS/ST interface module)

## Handheld

Startup and test of the ET 200B digital modules using the ET 200 Handheld is described in the *ET 200 Handheld* manual.

Starting up the ET 200B analog modules using the ET 200 Handheld is not possible.

## In this Chapter

This chapter describes startup and testing of the ET 200B using a programmer and **COM ET 200 V4.x**.

You will learn

- Which constraints are important for operation and testing (see Section 5.1)
- How to select the station and transfer the configuration data to the station (see Section 5.2)
- How you can test the station (see Section 5.3).

## COM ET 200 WINDOWS

If you are operating the ET 200B with **COM ET 200 WINDOWS**, you do not need to study this chapter.

The simple procedure for starting up slave stations with COM ET 200 WINDOWS is identical for all the ET 200 slaves and is not described in this manual. Please refer to the *ET 200 Distributed I/O System* manual (Order No. 6ES5 998-3ES12) for further details about whether or not test and startup functions are possible with COM ET 200 WINDOWS, and if so with which version.

COM ET 200 WINDOWS also provides extensive support for starting up the ET 200B modules through its integrated help system.



## 5.1 Constraints in Operation and Testing

### **Response Power Off/Power On**

In the case of "power off/power on" occurring repeatedly within a short period of time it is possible in exceptional cases that the ET 200B digital module will not be accepted by the SINEC L2-DP bus.

#### **Remedy:**

Switch the STOP/RUN switch to STOP and then back to RUN.

### **Baud Rate Change**

With the ET 200B digital modules, it is not possible to correct a wrong configuration and simultaneously to change the baud rate. If this is attempted, the station will not be accepted by the SINEC L2-DP bus.

#### **Remedy:**

Switch the STOP/RUN switch to STOP and then back to RUN.

### **Minimum Configuration**

If there is only one IM 308-B and only one ET 200B analog input module on the bus at a baud rate of  $\leq 93.75$  kbaud, it can happen that the analog input values will not be transferred to the IM 308-B (analog inputs = 0).

#### **Remedy:**

- Select "Programmer connected to the bus: Y" in COM ET 200
- or
- Select a higher baud rate
- or
- If you require a further ET 200B station for your application, operate this on the bus also.

## 5.2 Startup of the ET 200B Distributed I/O Station

### Precondition

The correct station number must be set on the terminal block.

---

### Note

A station number (set with a screwdriver, for example) only becomes valid when you have executed a cold restart on the ET 200B slave station (STOP-RUN switch changed from STOP → RUN position).

---

### Procedure When Selecting the Station

Execute the following steps to parameterize the ET 200B:

1. Connect the programmer (with CP5410 S5-DOS/ST interface module) to the SINEC L2-DP bus or directly to the ET 200B module.
2. Call up the "STARTUP/TEST" screen form of the COM ET 200 software package (<F5> in the "FUNCTIONS" screen form).
3. Enter the station number of the plugged-in ET 200B station.
4. Confirm the entry with <F6> (ENTER).

### Result

After a safety prompt, COM ET 200 establishes a connection with the plugged-in station, parameterizes it and branches to the "STARTUP/TEST: MODULE SELECTION" screen form if the configuration and the actual station structure agree.

If they do not agree, COM ET 200 reports an error in the message line. If this happens, you must correct the structure of the station in the "CONFIGURING" screen form.



---

### Caution

If you start up an ET 200B station during "bus operation" using the programmer connected to the bus, you must note the following: The station cannot be controlled by the master while it is being accessed by the programmer!

---

## Startup of the ET 200B Distributed I/O station, continued

### Example

In our example, the ET 200B station with station number “6” is to be started up.

Program file selected: TEST@ET.200				SIMATIC S5 / COM ET 200			
STARTUP / TEST: STATION SELECTION							
Station number: 6							
F1	F2	F3	F4	F5	F6	F7	F8
					ENTER	HELP	EXIT

Figure 5-1 “STARTUP/TEST: STATION SELECTION” Screen Form

### 5.3 Testing the ET 200B Distributed I/O Station

#### Starting Point

COM ET 200 branches automatically to the “STARTUP/TEST: MODULE SELECTION” screen form after parameterizing the ET 200B station (see Section 5.2).

#### How to Proceed When Selecting the Slots

Execute the following steps to select the slots of the input or output ports:

1. Position the cursor at the slot of the ET 200B station whose input status you want to evaluate or whose outputs you want to control.
2. Press <F5> (SELECT).

#### Result:

The selected slot is marked with a “\*”. Press <F5> (SELECT) again to undo the selection.

3. Confirm the selection with <F6> (ENTER).

#### Result

The “STARTUP/TEST: STATUS/CONTROL” screen form for the selected station appears with the following contents:

The “Station status” output field contains diagnostics messages in plain text concerning the entire station.

Two tables show the inputs and outputs in “KH” format:

## Testing the ET200B Distributed I/O station, continued

### Example

In our example, the ET 200B-4AI analog input module (address ID 4AI) is tested.

Program file selected: TEST@ET.200				SIMATIC S5 / COM ET 200			
STARTUP / TEST: STATUS/CONTROL							
Station number: 6				Station type: B-4AI DP			
Station name: PRESS							
Station status: Station cannot be controlled by PLC							
Slot: 0		ID: 4AI					
Control							
-----							
Outputs							
Status							
-----							
Inputs							
KH = 2CA0 0000 0000 0000							
<b>F1</b>	<b>F2</b>	<b>F3</b>	<b>F4</b>	<b>F5</b>	<b>F6</b>	<b>F7</b>	<b>F8</b>
					ENTER	HELP	EXIT

Figure 5-2 "STARTUP/TEST: STATUS/CONTROL" Screen Form

### How to Proceed When Testing Inputs

Execute the following steps to test inputs:

1. Specify the input signals (sensor signals) for the module.
2. Press <F6> (ENTER).

#### **Result:**

The input data of the selected module and the (station) diagnostics data are requested. The diagnosis appears as plain text in the "Station status" field.

The assignments of the function keys on the screen form change.

3. Press <F6> (STOP) to freeze the screen, that is to stop the output fields in the "Inputs" line from being updated.

### Example

Displayed inputs in the case of the ET 200B-4AI (address ID 4AI):

Channel	0	1	2	3
<b>KH =</b>	<b>0100</b>	<b>00FF</b>	<b>00AB</b>	<b>01AA</b>

## Testing the ET 200B Distributed I/O Station, continued

### How to Proceed When Testing Outputs

Execute the following steps to test outputs:

1. Enter output signals in the "Outputs" line.
2. Press <F6> (ENTER).

#### Result:

The output data is transferred cyclically to the selected module.

The assignments of the function keys on the screen form change.

3. Press <F6> (STOP) to freeze the screen, that is to stop the outputs from being controlled.



#### Caution

Setting outputs when the load current circuit is switched on can cause hazardous plant conditions.

Outputs are only reset in the following cases:

- If you call the MODULE SELECTION screen form
  - If you reset the outputs in the MODULE SELECTION screen form
  - If you exit the MODULE SELECTION screen form with <F8> (EXIT) and "YES".
- 

### Example

Set outputs in the case of the ET 200B-32DO (address ID 035):

Byte	0	1	2	3
<b>KH =</b>	<b>2C</b>	<b>A0</b>	<b>01</b>	<b>34</b>

# Fault Diagnostics

# 6

## In this Chapter

This chapter describes the fault diagnostics of the ET 200B distributed I/O station.

You will find notes on locating faults:

- Via LEDs on the front of the module (see Section 6.1)
- Using **COM ET 200 V4.x** on the programmer (see Section 6.2)
- Via STEP 5 (station diagnostics) in combination with an **IM 308-B** (see Section 6.3)
- Via STEP 5 (station diagnostics) in combination with an **IM 308-C** (see Section 6.4)

## COM ET 200 WINDOWS

If you are operating the ET 200B with **COM ET 200 WINDOWS**, you do not need to study Section 6.2.

The simple procedure for diagnosing faults in slave stations with COM ET 200 WINDOWS is identical for all ET 200 slaves and is not described in this manual. Please refer to the *ET 200 Distributed I/O System* manual (Order No. 6ES5 998-3ES12) for further details about whether or not fault diagnostics are possible with COM ET 200 WINDOWS, and if so with which version.

COM ET 200 WINDOWS also provides extensive support for starting up the ET 200B modules through its integrated help system.



## 6.1 Fault Diagnostics Through LEDs

**Introduction** The LEDs on the front of the ET 200B modules give you initial information on the type of fault.

**Fault Indications** Table 6-1 explains the meanings of the LED signals on the ET 200B modules.

Table 6-1 LED Indicators

LED	Indication	Meaning
RUN	Lit (green)	ET 200B in operation (power supply switched on; STOP/RUN switch in "RUN" position <sup>1</sup> ).
BF	Lit (red)	The monitoring time has elapsed without the ET 200B station being addressed (either because the connection to the IM 308-B or IM 308-C has failed or because the IM 308-B or IM 308-C is set to STOP)  or  The ET 200B station was not parameterized during startup/restart.
DIA	Lit (red)	For digital 24 V DC output modules: <ul style="list-style-type: none"> <li>Short-circuit or load voltage failure (L1+, L2+, L3+, L4+) at at least one output</li> </ul> For analog modules: <ul style="list-style-type: none"> <li>Diagnosis for at least one input or output</li> </ul>
L1+	Lit (green)	For ET 200B-16DO 8DI/8DO, 24DI/8DO and 24DI/8DO 0.2 ms: <ul style="list-style-type: none"> <li>Voltage is applied for channel group Q0: .0 to .7.<sup>2</sup></li> </ul>
L2+	Lit (green)	For ET 200B-16DO: <ul style="list-style-type: none"> <li>Voltage is applied for channel group Q1: .0 to .7.<sup>2</sup></li> </ul>
L1+/L2+	Lit (green)	For ET 200B-32DO: <ul style="list-style-type: none"> <li>Voltage is applied for channel groups Q0: .0 to .7 and Q1: .0 to .7.<sup>2</sup></li> </ul> For ET 200B-16DO/2A: <ul style="list-style-type: none"> <li>Voltage is applied for channel groups Q0: .0 to .3 and Q0: .4 to .7.<sup>2</sup></li> </ul>
L3+/L4+	Lit (green)	For ET 200B-32DO: <ul style="list-style-type: none"> <li>Voltage is applied for channel groups Q2: .0 to .7 and Q3: .0 to .7.<sup>2</sup></li> </ul> For ET 200B-16DO/2A: <ul style="list-style-type: none"> <li>Voltage is applied for channel groups Q1: .0 to .3 and Q1: .4 to .7.<sup>2</sup></li> </ul>

<sup>1</sup> Not 120/230 V AC digital modules. These have no STOP/RUN switch.

<sup>2</sup> LED goes out if fuse blows or voltage drops below a certain limit (typically: 15.5 V).

## 6.2 Fault Diagnostics with COM ET 200 V4.x

### Introduction

The COM ET 200 software package provides the “DIAGNOSTICS” screen form for diagnostics functions.

### Precondition

The following preconditions must be met before using the diagnostics functions:

- You must have connected a programmer to the SINEC L2-DP bus using the CP5410 S5-DOS/ST programmer interface module.
- You must have indicated “Programmer connected to the bus: Y” in the “ET 200 SYSTEM PARAMETERS” screen form.
- The selected program file must be identical to the program file on the E(E)PROM.

### How to Proceed When Requesting Station Diagnostics

Execute the following steps to request station diagnostics:

1. Call the “DIAGNOSTICS: OVERVIEW” screen form (<F6> in the “FUNCTIONS” screen form).

#### Result:

All numbers of stations on which diagnostics data is available are listed under “Station number” in the screen form.

2. Press <F1> (INDIVIDUAL DIAGNOSTICS).

#### Result:

COM ET 200 prompts you for a “Station number”.

3. Enter the number of the faulty station you wish to diagnose in the “Station number” input field.
4. Press <F6> (ENTER) in order to evaluate diagnostics messages from this station.

### Result

After you press <F6> (ENTER), COM ET 200 branches to the “INDIVIDUAL DIAGNOSTICS” screen form with the following contents:

The diagnostics messages for the entire station are displayed in the “Station status” output field in plain text (see Figure 6-1).

The “**Device-Related Diagnostics**” give the channel-group-related diagnostics in “KH” format. See Sections 6.3.5 and 6.3.6 for more detailed information on the structure of the device-related diagnostics of the ET 200B.

## Fault Diagnostics with COM ET 200 V4.x, continued

### Example

In our example, one or more signal sensor lines of the ET 200B-4AI are interrupted. The ET 200B-4AI has device-related diagnostics of 9 bytes.

See Section 6.3.6 for the precise meaning of the bytes.

Programm file selected: TEST@@ET.200 SIMATIC S5 / COM ET 200  
**INDIVIDUAL DIAGNOSTICS**

---

Station number: 10 Station type: B-4AI DP  
 Station name: Press control  
 Station status: External Diagnostics

Byte 0
Byte 8

Device-related diagnostics:

---

KH = 00 00 0B 15 00 00 71 08 04

Identifier-related diagnostics:

Slot:

---

Active

F1	F2	F3	F4	F5	F6	F7	F8
							<b>EXIT</b>

Figure 6-1 "INDIVIDUAL DIAGNOSTICS" Screen Form

## 6.3 Fault Diagnostics with STEP 5 (Station Diagnostics) in Combination with an IM 308-B

### Introduction

You can locate and evaluate a fault systematically with STEP 5.

### Diagnostics Functions Using STEP 5

Table 6-2 lists the STEP 5 diagnostics functions in combination with an IM 308-B:

Table 6-2 Diagnostics Functions Using STEP 5 in combination with an IM 308-B

<b>Diagnostics</b>	<b>Information</b>
Diagnostics "Overview"	Determines all stations for which diagnostics data is available.
Diagnostics for "Parameterization and accessibility"	Determines the stations which are parameterized and can be contacted.
Station diagnostics	Provides information on the status of the slave station and displays diagnostics data for individual channel groups (only in the case of modules with diagnostics capability).

### Diagnostics "Overview" and "Parameterization and Accessibility"

The "Overview" and "Parameterization and Accessibility" diagnostics functions each comprise two bytes organized in one word.

## Fault Diagnostics with STEP 5 (Station Diagnostics) in Combination with an IM 308-B, continued

**Structure:  
Station  
Diagnostics**

16 bytes are reserved per slave station for station diagnostics purposes. The 16 bytes are organized into 8 words.

To avoid misunderstandings, the two diagnostics bytes of the diagnostics word will be referred to in the following as “diagnostics address” and “diagnostics address +1”.

You will find a description of device-related diagnostics as follows:

- In Section 6.3.5 for digital ET 200Bs
- In Section 6.3.6 for analog ET 200Bs

Table 6-3 Structure of the Station Diagnostics for the ET 200B in combination with an IM 308-B

Code	Diagnostics Address	Diagnostics Address + 1
0	Station status 1	Station status 2
1	Station status 3	Master address
2	Manufacturer identification	
3	<b>Digital:</b> Header <b>Analog:</b> Header	<b>Digital:</b> Device-related diagnostics (group diagnostics) <b>Analog:</b> Reserved (byte 0)
4	<b>Digital:</b> Free <b>Analog:</b> Device-related diagnostics (byte 1) (reserved)	<b>Digital:</b> Free <b>Analog:</b> Device-related diagnostics (byte 2) (system-related diagnostics)
5	<b>Digital:</b> Free <b>Analog:</b> Device-related diagnostics (byte 3) (system-related diagnostics)	<b>Digital:</b> Free <b>Analog:</b> Device-related diagnostics (byte 4) (system-related diagnostics)
6	<b>Digital:</b> Free <b>Analog:</b> Device-related diagnostics (byte 5) (system-related diagnostics)	<b>Digital:</b> Free <b>Analog:</b> Device-related diagnostics (byte 6) (input or output channels)
7	<b>Digital:</b> Free <b>Analog:</b> Device-related diagnostics (byte 7) (reserved)	<b>Digital:</b> Free <b>Analog:</b> Device-related diagnostics (byte 8) (no. of channels)

**Requesting Diagnostics**

The diagnostics are loaded word by word and transferred to the diagnostics word. (The load and transfer operations always refer in the following to the default diagnostics address 252.)

In the case of dual-port RAM addressing, the diagnostics word is located on the “basic page”. Before requesting diagnostics in the case of dual-port RAM addressing, you must also “switch” to the basic page number.

Structure of the STEP 5 listing for diagnostics:

STL	Explanation
L KB (basic page number)	Page selection
T PY 255	(basic page number: nx16, n=0,1,..)
L KY (station number),(code)	Load diagnostics (station number: 3 to 99, code: -> Table 6-3) and transfer to the diagnostics word (diagnostics word: in this case, PW 252).
T PW 252	
L PW 252	Evaluate diagnostics word (hex code: -> Sections 6.3.1 to 6.3.6)
L KH (hex-code: no error)	Error?
!=F	
BEC	
JC FBx	Evaluate error in FBx

### 6.3.1 Diagnostics “Overview” with IM 308-B

#### Introduction

The diagnostics “Overview” encompasses all stations for which diagnostics data is available.

#### Requesting the Diagnostics “Overview”

Program the following in STEP 5:

STL	Explanation
L KY 127,n T PW 252	Store the value 127 (code for requesting the diagnostics “Overview”) in the “Diagnostics address” byte; store in the “Diagnostics address +1” byte the code for the station numbers of the stations from which the diagnostics “Overview” are to be requested (the diagnostics “Overview” cover station (n x 16) to station (n x 16 + 15) in each case!)
L PW 252	Load diagnostics word
L KH 0000	
!=F	No station with errors?
BEC	
JC FBx	Evaluate error in FBx

**Structure:  
Diagnostics Word  
“Overview”**

The diagnostics word has the following structure after requesting the diagnostics “Overview”:

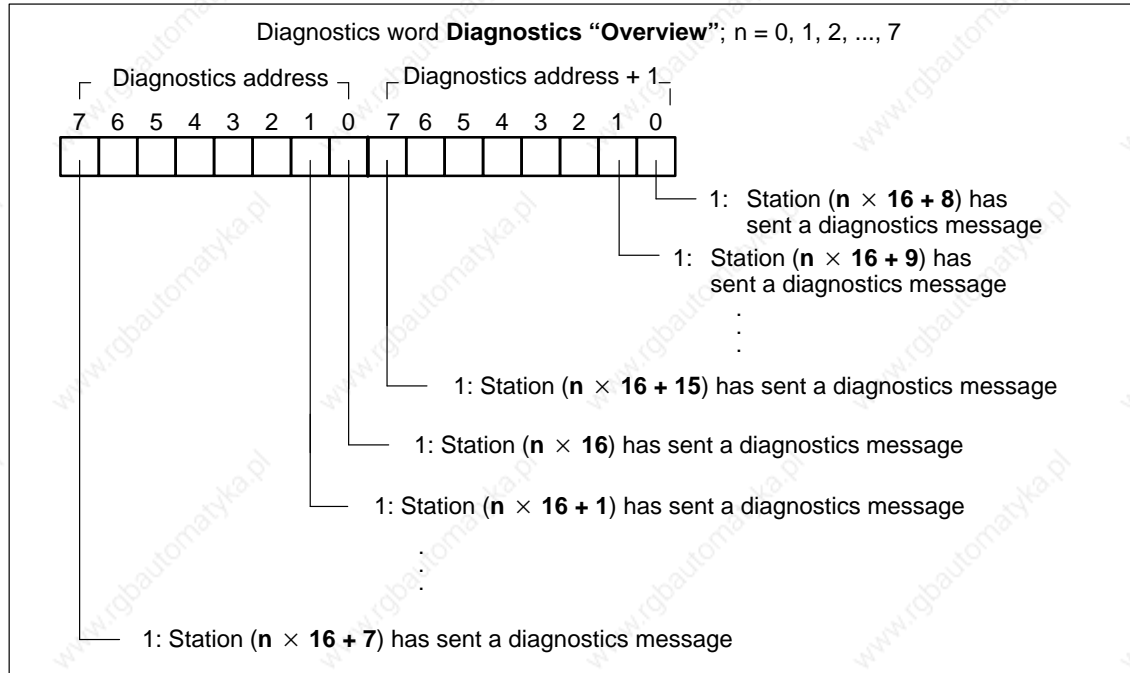

Figure 6-2 Structure of the Diagnostics Word After Requesting the Diagnostics “Overview”



### 6.3.2 Diagnostics “Parameterization and Accessibility” with IM 308-B

#### Introduction

The diagnostics “Parameterization and Accessibility” encompass all stations which have been parameterized and are accessible.

#### Requesting the Diagnostics “Parameterization and Accessibility”

Program the following in STEP 5:

STL	Explanation
L KY 126,n T PW 252	Store the value 126 (code for requesting the diagnostics “Parameterization and Accessibility”) in the “Diagnostics address” byte; store in the “Diagnostics address +1” byte the code for the station numbers of the stations from which the diagnostics “Parameterization and Accessibility” are to be requested (the diagnostics cover station (n x 16) to station (n x 16 + 15) in each case!)
L PW 252	Load diagnostics word
L KH FFFF !=F	No station with errors?
BEC	
JC FBx	Evaluate error in FBx.

**Structure:  
Diagnostics Word  
“Parameterization  
and Accessibility”**

The diagnostics word has the following structure after requesting the diagnostics “Parameterization and Accessibility”:

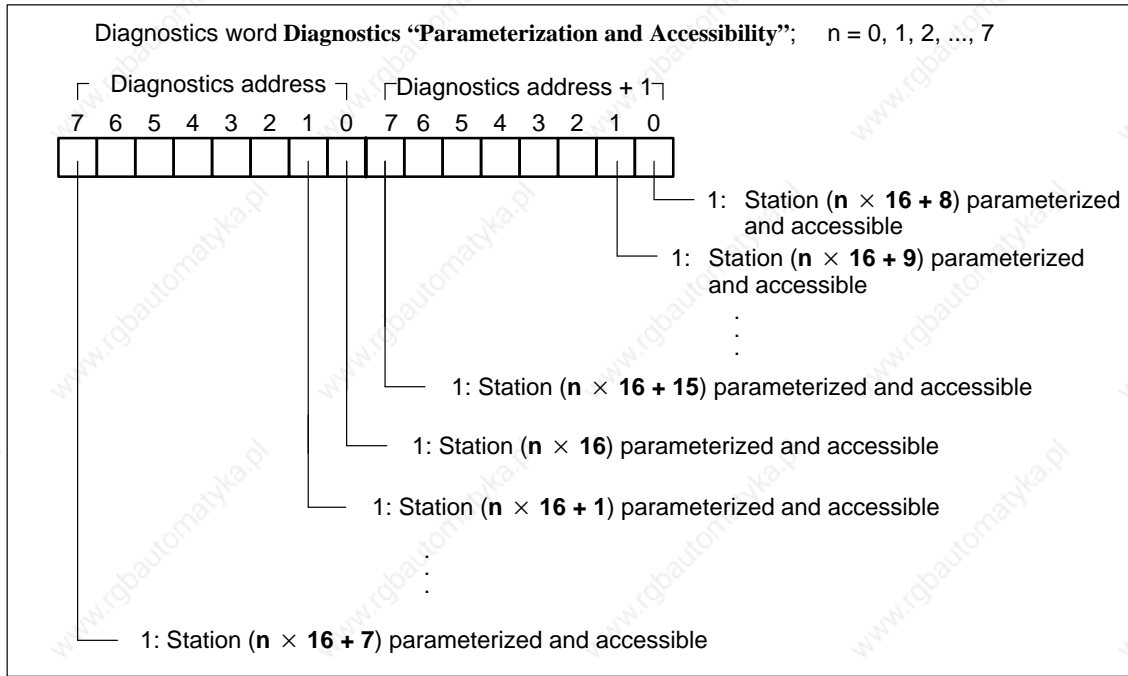

Figure 6-3 Structure of the Diagnostics Word After Requesting the Diagnostics “Parameterization and Accessibility”

**Diagnostics  
“Overview” and  
“Parameterization  
and Accessibility”**

The following diagnostics messages can be generated by combining diagnostics “Overview” and diagnostics “Parameterization and Accessibility”:

Table 6-4 Combination of Diagnostics “Overview” and Diagnostics “Parameterization and Accessibility”

Overview	Parameterization and Accessibility	Meaning: Station is ...
0	0	... not parameterized and not accessible
0	1	... error-free and accessible
1	0	... parameterized and not accessible
1	1	... contains errors but is accessible

### 6.3.3 Station Status Diagnostics with IM 308-B

#### Introduction

The diagnostics bytes “Station status 1 to 3” give information on the station. The station number of the master station which has parameterized the slave station is stored in the “Master address” diagnostics byte.

#### Requesting Station Status 1 and 2

Program the following in STEP 5:

STL	Explanation
L KY n,0 T PW 252	Store in the “Diagnostics address” byte the number of the slave station (n = station number) from which the station status is to be requested; store the code for “Station status 1 and station status 2” (code = 0) in the “Diagnostics address +1” byte.
L PW 252 L KH 000C !=F BEC JC FBx	Load the diagnostics word Threshold monitoring activated No error? Evaluate error in FBx

**Structure:** The diagnostics word has the following structure when station status 1 and 2 (code = 0) has been requested:

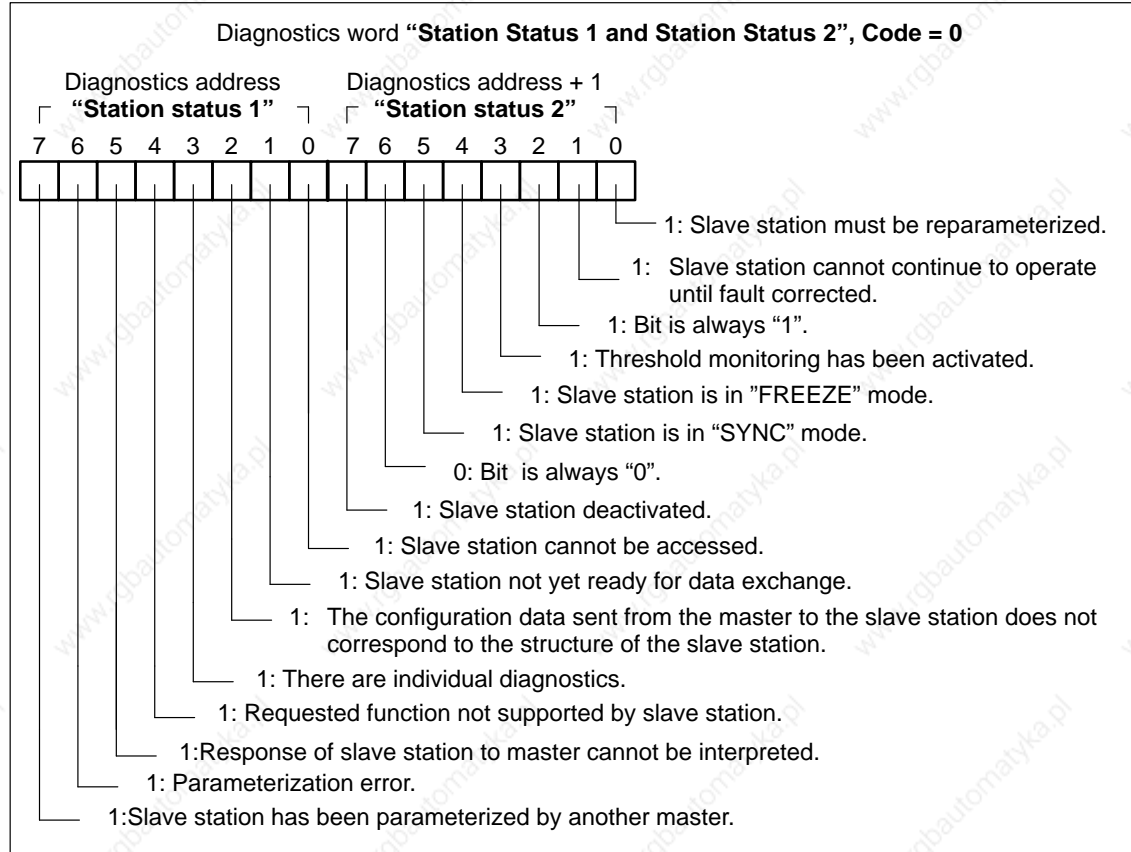

Figure 6-4 Structure of the Diagnostics Word (Station Status 1 and Station Status 2)

**Note**

If you are operating with the IM 308-B and the slave station has not been configured with COM ET 200 (V4.0), the diagnostics word "Station status 1 and station status 2" has the following structure (in KH format):

Station status 1: 01<sub>H</sub>

Station status 2: 44<sub>H</sub>

## Station Status Diagnostics with IM 308-B, continued

### Requesting Station Status 3 and Master Address

Program the following in STEP 5:

STL	Explanation
L KY n,1 T PW 252	Store the number of the slave station (n = station number) from which the master address is to be requested in the "Diagnostics address" byte; store the code for "Station status 3 and master address" (code = 1) in the "Diagnostics address + 1" byte.

### Structure: Diagnostics Word Station Status 3 and Master Address

The diagnostics word has the following structure after station status 3 and the master address (code = 1) has been requested.

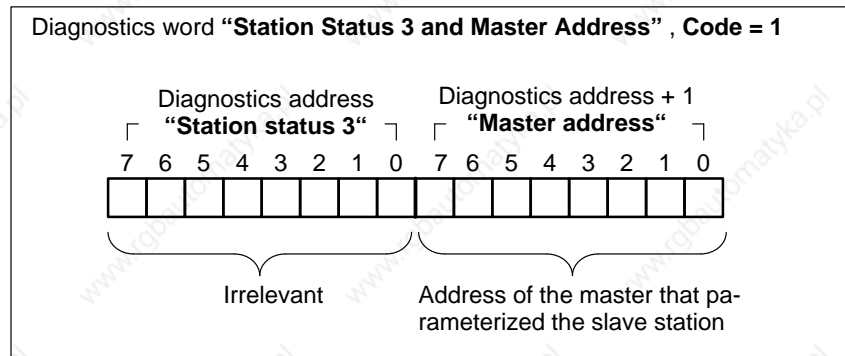

Figure 6-5 Structure of the "Station Status 3 and Master Address" Diagnostics Word

### 6.3.4 Diagnostics of the Manufacturer Identification with IM 308-B

#### Introduction

The “Manufacturer identification” diagnostics word describes the type of the slave station.

#### Requesting the Manufacturer Identification

Program the following in STEP 5:

STL	Explanation
L KY n,2	Store the number of the slave station (n = station number) from which the manufacturer identification is to be requested in the “Diagnostics address” byte; store the code for “Manufacturer identification” (code = 2) in the “Diagnostics address +1” byte.
T PW 252	
L PW 252	Load the manufacturer identification (e.g. “0001 <sub>H</sub> ” for ET 200B-16DI)
L KH 0001	
! =F	No error?
BEC	
JC FBx	Evaluate error in FBx.

## Diagnostics of the Manufacturer Identification with IM 308-B, continued

**Structure:** The diagnostics word has the following structure when the manufacturer identification (code = 2) has been requested:  
**Diagnostics Word**  
**Manufacturer Identification**

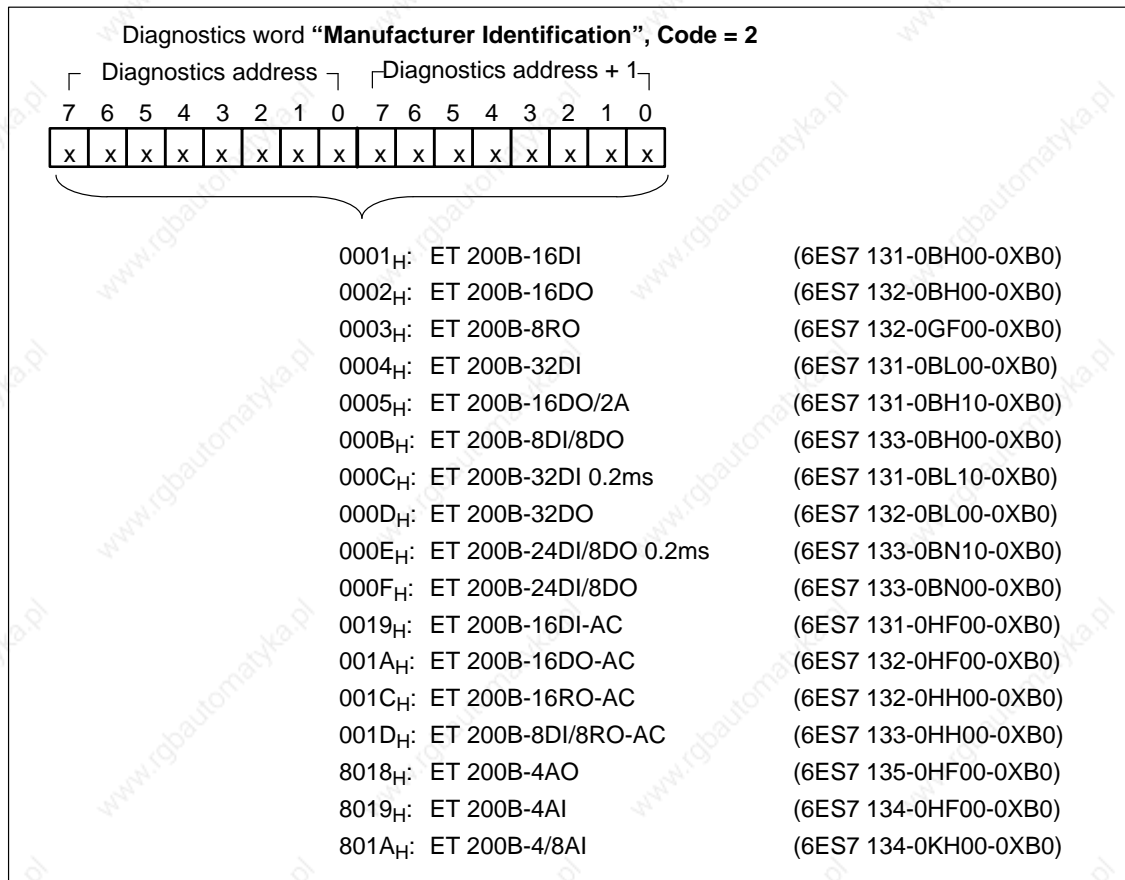

Figure 6-6 Structure of the “Manufacturer Identification” Diagnostics Word

### 6.3.5 Device-Related Diagnostics (Digital ET 200B) in the Case of Operation with IM308-B

#### Introduction

You can detect faults in inputs and outputs using device-related diagnostics. The header gives information on the length of the device-related diagnostics.

#### Note

Device-related diagnostics are only possible in the case of ET 200B stations with diagnostics capability.

ET 200B stations **without** diagnostics capability contain the value "07H" in the header and the remaining bytes are reserved.

#### Requesting Device-Related Diagnostics

Program the following in STEP 5:

STL	Explanation
L KY n,3 T PW 252	Store the number of the slave station (n = station number) from which the device-related diagnostics are to be requested in the "Diagnostics address" byte; store the code for "Header and device-related diagnostics" (code = 3) in the "Diagnostics address +1" byte.
L KH 0700 L PW 252	Load the diagnostics word.
!=F BEC	No error?
JC FBx	Evaluate error in FBx.



## Device-Related Diagnostics (Digital ET 200B) in the Case of Operation with IM 308-B, continued

**Structure:  
Diagnostics Word  
Header and  
Device-Related  
Diagnostics**

The diagnostics word has the following structure after device-related diagnostics (code = 3) has been requested in the case of digital ET 200B modules:

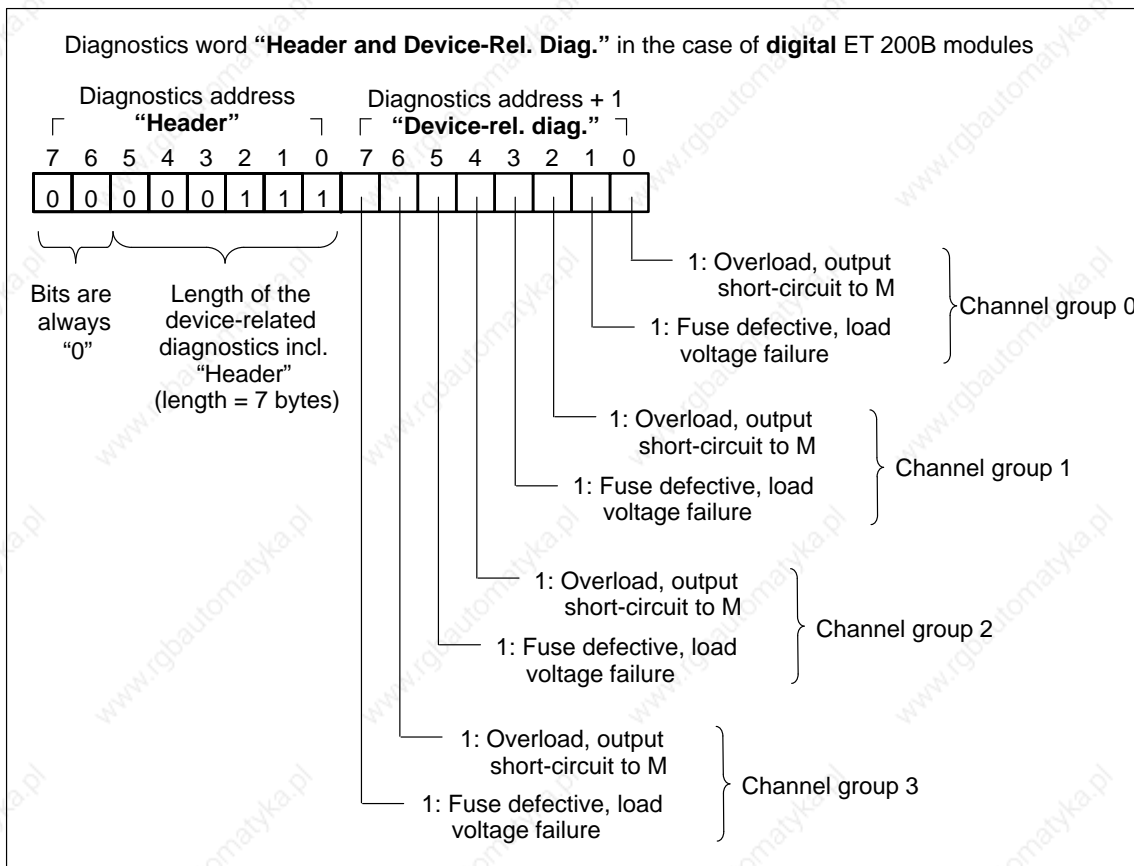

Figure 6-7 Structure of the "Header and Device-Related Diagnostics" Diagnostics Word in the Case of Digital ET 200B Modules

**Note**

The channel group of a digital ET 200B module always comprises one byte in the S5 address range of the CPU (corresponding to 8 inputs or 8 outputs), irrespective of the galvanic isolation of the module (grouping).

**Example:** ET 200B-16DO/2A (galvanic isolation in groups of 4)

Channel group 0 corresponds to Q0: outputs .0 ... .7.

Potential group 0 corresponds to Q0: outputs .0 ... .3.

### 6.3.6 Device-Related Diagnostics (Analog ET 200B) in the Case of Operation with IM 308-B

#### Introduction

Using the device-related diagnostics for an analog ET 200B, you can detect which faults the ET 200B reports. The header gives information on the length of the device-related diagnostics.

#### Note

Under analog value representation in Chapter 9, you will find "Supplementary Bits" which will provide you with additional diagnostics information.

#### Requesting Device-Related Diagnostics

To request device-related diagnostics for an analog ET 200B, program the following in STEP 5:

STL	Explanation
L KY n,4 T PW 252	Store the number of the slave station (n = station number) from which device-related diagnostics are to be requested in the "Diagnostics address" byte; store the code for "Device-related diagnostics (byte 1, 2)" in the "Diagnostics address +1" byte.
L KH 0000 L PW 252	Load the diagnostics word
!=F	No error?
BEC	
JC FBx	Evaluate error in FBx.

Select code = 5 (bytes 3, 4), 6 (bytes 5, 6) or 7 (bytes 7, 8) for further device-related diagnostics.

## Device-Related Diagnostics (Analog ET 200B) in the Case of Operation with IM 308-B, continued

**Structure:** The diagnostics word “Header” has the following structure after device-related diagnostics (code = 3) has been requested in the case of analog ET 200B modules:  
**Diagnostics Word Header**

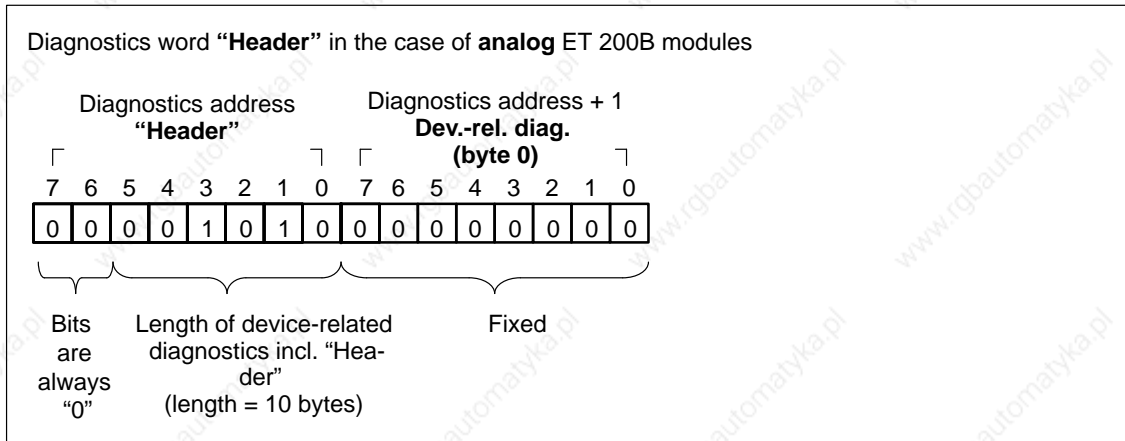

Figure 6-8 Structure of the “Header” Diagnostics Word in the Case of Analog ET 200B Modules

**Structure:** The diagnostics word has the following structure after device-related diagnostics (code = 4) has been requested in the case of analog ET 200B modules:  
**Diagnostics Word Device-Related Diagn. (Byte 2)**

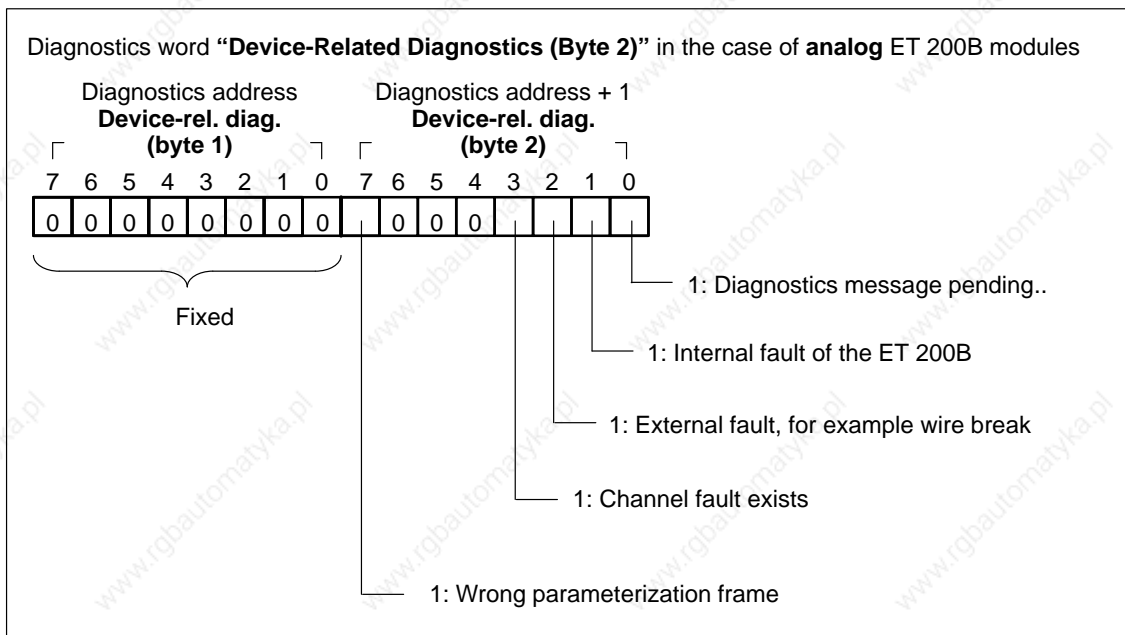

Figure 6-9 Structure of the “Device-Related Diagnostics (Byte 2)” Diagnostics Word in the Case of Analog ET 200B Modules

**Structure:**  
**Diagnostics Word**  
**Device-Related**  
**Diag. (Bytes 3, 4)**

The diagnostics word has the following structure after device-related diagnostics (code = 5) has been requested in the case of analog ET 200B modules:

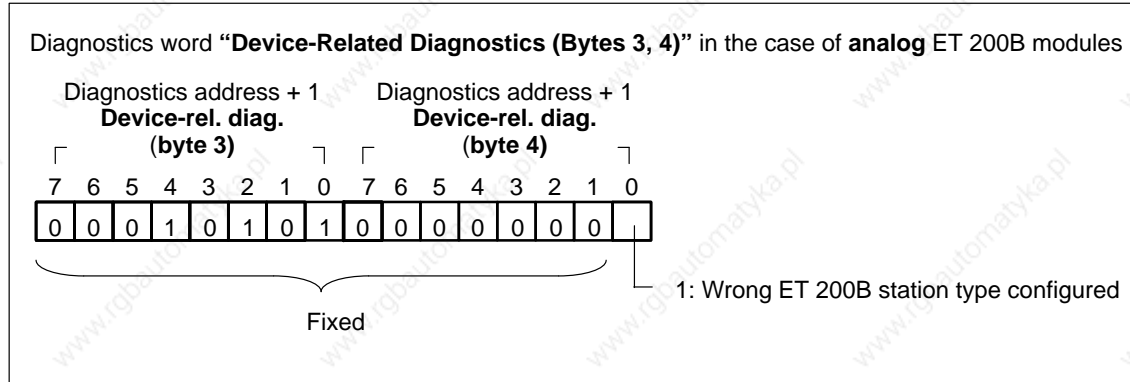

Figure 6-10 Structure of the “Device-Related Diagnostics (Bytes 3, 4)” Diagnostics Word in the Case of Analog ET 200B Modules

**Structure:**  
**Diagnostics Word**  
**Device-Related**  
**Diagn. (Bytes 5, 6)**

The diagnostics word has the following structure after device-related diagnostics (code = 6) has been requested in the case of analog ET 200B modules:

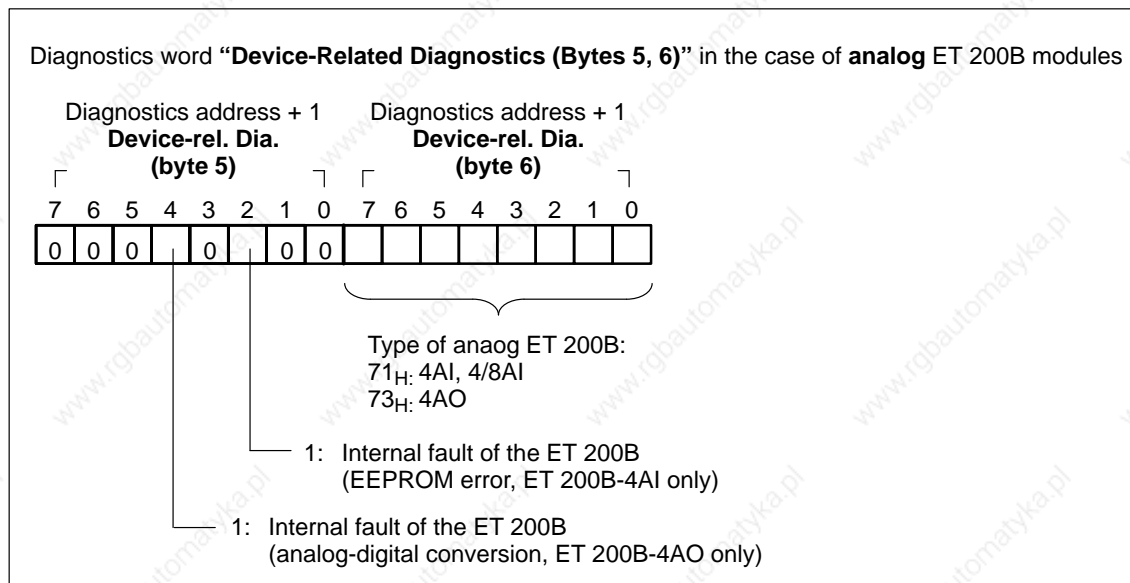

Figure 6-11 Structure of the “Device-Related Diagnostics (Byte 5, 6)” Diagnostics Word in the Case of Analog ET 200B Modules

## Device-Related Diagnostics (Analog ET 200B) in the Case of Operation with IM 308-B, continued

**Structure:** The diagnostics word has the following structure after device-related diagnostics (code = 7) has been requested in the case of analog ET 200B modules:

**Diagnostics Word Device-Related Diagnostics (Bytes 7, 8)**

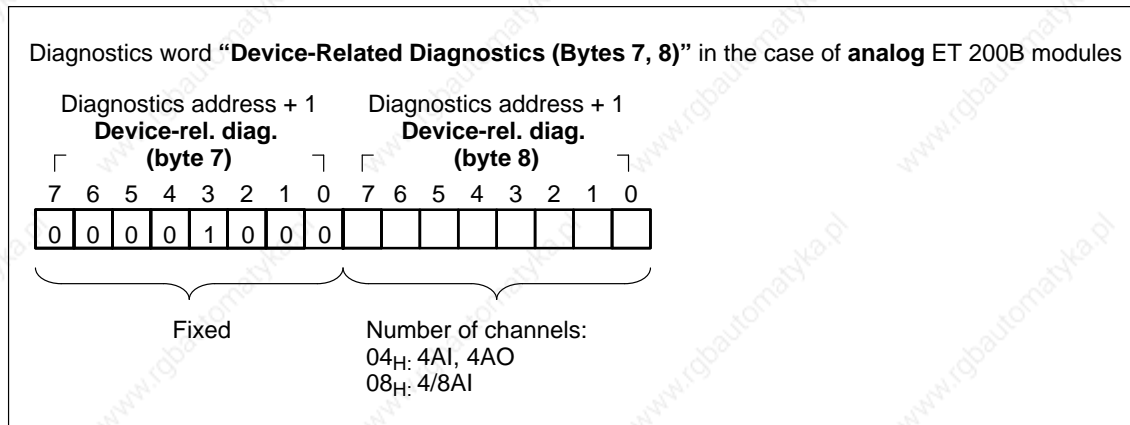

Figure 6-12 Structure of the “Device-Related Diagnostics (Byte 7, 8)” Diagnostics Word in the Case of Analog ET 200B Modules

## 6.4 Fault Diagnostics with STEP 5 (Station Diagnostics) in Combination with an IM 308-C

### Introduction

You can locate and evaluate a fault systematically with STEP 5.

### Diagnostics Functions Using STEP 5

Table 6-5 lists the STEP 5 diagnostics functions in combination with an IM 308-C:

Table 6-5 Diagnostics Functions Using STEP 5 in Combination with an IM 308-C

Diagnosics	Contents
Master diagnostics	<ul style="list-style-type: none"> <li>• Determines all slaves for which diagnostics data is available.</li> <li>• Determines all slaves with which data transfers have taken place during a specified period.</li> <li>• Provides information on the operating mode of the DP master.</li> </ul>
Station diagnostics	Provides information on the status of the slave and displays diagnostics data separately for each channel group (only in the case of modules with diagnostics capability).

### In this Section

Master diagnostics with the IM 308-C are independent of the station type of the slaves. They are described in detail in the *ET 200 Distributed I/O System* manual (Order No. 6ES5 998-3ES12).

**Station diagnostics** for the **ET 200B** are described below.

## Fault Diagnostics with STEP 5 (Station Diagnostics) in Combination with an IM 308-C, continued

### Structure: Station Diagnostics

25 bytes are reserved per slave station for station diagnostics purposes.

Table 6-6 shows the structure of the station diagnostics for the ET 200B:

Table 6-6 Structure of the Station Diagnostics for the ET 200B in Combination with an IM 308-C

Byte	Contents
Diagnostics byte 0	Station status 1
Diagnostics byte 1	Station status 2
Diagnostics byte 2	Station status 3
Diagnostics byte 3	Master station number
Diagnostics byte 4	Manufacturer identification (high)
Diagnostics byte 5	Manufacturer identification (low)
Diagnostics byte 6	Header (device-related diagnostics)
Diagnostics byte 7	<b>Digital:</b> Device-related diagnostics (group diagnostics) <b>Analog:</b> Device-related diagnostics (byte 0)
Diagnostics bytes 8 to 24	<b>Digital:</b> Free <b>Analog:</b> Device-related diagnostics (bytes 1 to 17)

### Requesting Station Diagnostics

In order to request the station diagnostics for an ET 200B station, you must invoke the FB IM308C function block (FB 192) with the FCT = SD function.

FB IM308C saves the station diagnostics in the S5 data area of the CPU which was opened by the function block call (data block or flag area).

### Description

FB IM308C handling comprises general access to the diagnostics data of the IM 308-C and is described in detail in the *ET 200 Distributed I/O System* manual (Order No. 6ES5 998-3ES12).

The example given below shows how you can request the station diagnostics with the aid of FB IM308C and save them in a data block.

The procedure for analyzing the station diagnostics is described next. We have assumed that the diagnostics data have already been saved in a data block.

**Example: Requesting Diagnostics with FB IM308C**

This example shows how the station diagnostics of a slave with station number 3 can be requested with FB IM308C (FB 192). The diagnostics data should be saved in data block DB 10, starting at data word DW 0.

Basic structure of the STEP 5 listing (e.g. in OB 1):

STL	Explanation
:	
:JU FB 192	Invoke FB IM308C
Name:IM308C	DP frame: F800
DPAD: KH F800	Number of IM 308-C: 0, station number of slave: 3
IMST: KY 0,3	SD = Read slave diagnostics
FCT: KS SD	Irrelevant
GCGR: KM 00000000 00000000	Page: 0, block: DB 10
TYP: KY 0,10	Number of first data word: DW 0
STAD: KF +0	Bytes to be transferred: -1 (joker length)
LENG: KF -1	Error word: MW 134
ERR: FW 134	
:	
:***	

**Note**

The block parameters of FB IM308C and the error numbers in the ERR parameter of FB IM308C are described in detail in the *ET 200 Distributed I/O System* manual (Order No. 6ES5 998-3ES12).



### 6.4.1 Station Status Diagnostics with IM 308-C

**Introduction**

The diagnostics bytes "Station status 1 to 3" give information on the station. The number of the station which has parameterized the slave station is stored in the "Master station number" diagnostics byte.

**Assumption**

The station diagnostics of a digital ET 200B module have been requested by the CPU; they are saved in a data block (DB) starting at data word DW n (n = 0).

Table 6-7 shows the position of the diagnostics data in a data block:

Table 6-7 Position of the Diagnostics Data in a Data Block

Data Word	DL	DR
DW n	Station status 1	Station status 2
DW n + 1	Station status 3	Master station number
DW n + 2	Manufacturer identification	
DW n + 3	Header	Device-related diagnostics (byte 0)
...	...	...
DW n + 12	Device-related diagnostics (byte 17)	Free

n = Word address starting at which the diagnostics data is saved in the DB.

**Reading Station Status 1 and 2**

Program the following in STEP 5:

STL	Explanation
C DB 10	Invoke the data block (in this example: DB 10)
L DW 0	Load the diagnostics word "Station status 1 and station status 2"
L KH 0004	"No error?"
!=F	
BEC	
JC FBx	Evaluate error in FBx.

**Structure: Diagnostics Word Station Status 1 and 2**

The diagnostics word has the following structure for station status 1 and 2 (in this example: DW 0):

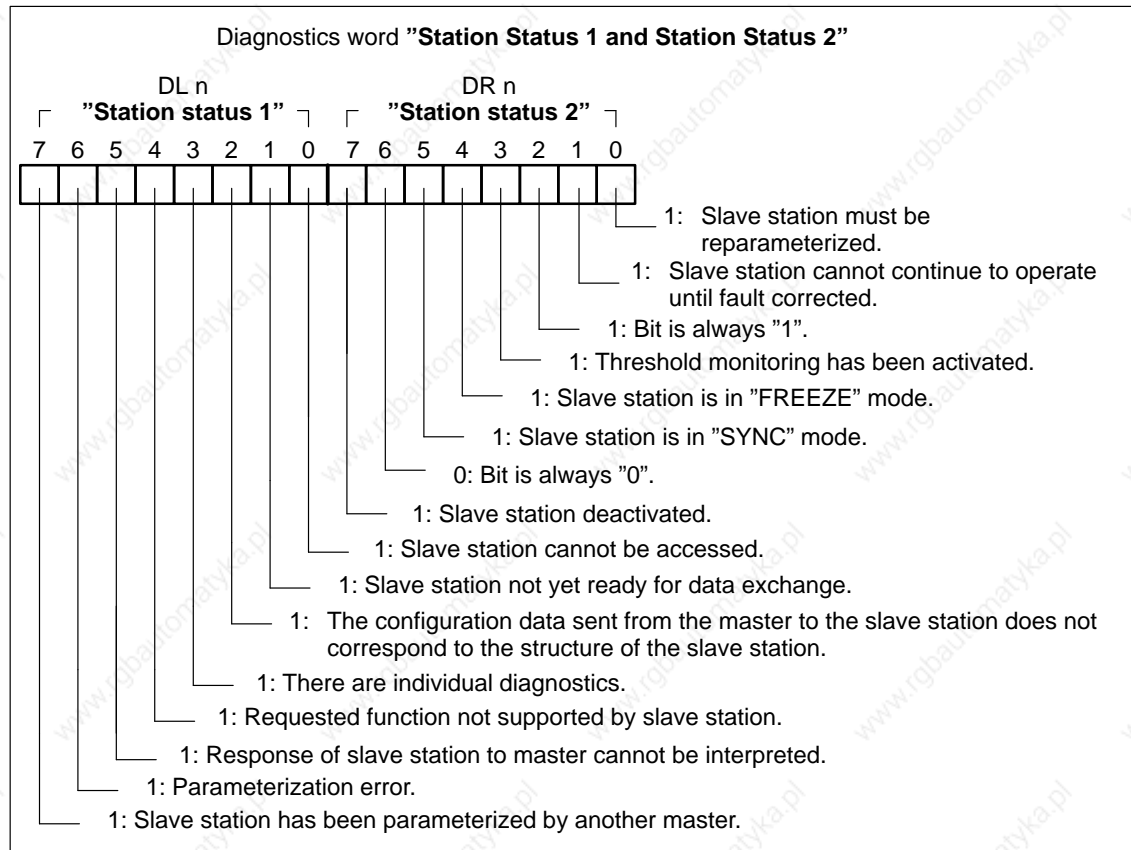

Figure 6-13 Structure of the Diagnostics Word (Station Status 1 and Station Status 2)

## Station Status Diagnostics with IM 308-C, continued

### Reading Station Status 3 and Master Station Number

Program the following in STEP 5:

STL	Explanation
C DB 10	Invoke the data block (in this example: DB 10)
L DW 1	Load the diagnostics word "Station status 3 and master station number" (in this example: 1)
L KH 0001	

### Structure: Diagnostics Word Station Status 3 and Master Station Number

The diagnostics word has the following structure for station status 3 and the master station number (in this example: DW 1):

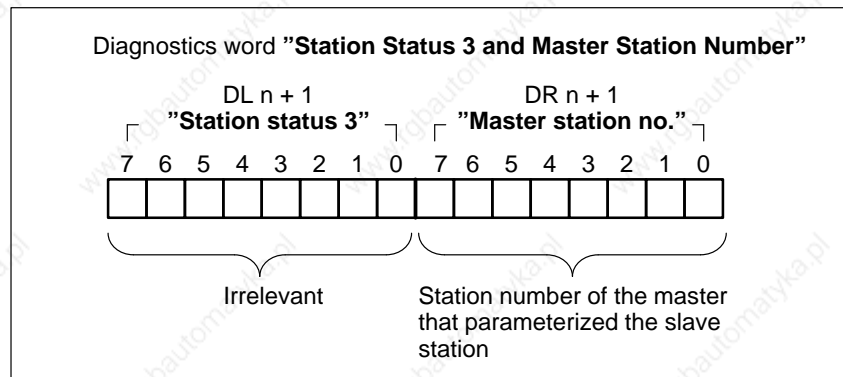

Figure 6-14 Structure of the "Station Status 3 and Master Station Number" Diagnostics Word

## 6.4.2 Diagnostics of the Manufacturer Identification with IM 308-C

### Introduction

The "Manufacturer identification" diagnostics word describes the type of the slave station.

### Assumption

The station diagnostics have been requested by the CPU; they are saved in data block DB 10 starting at data word DW n (n = 0) (see Table 6-7).

### Reading the Manufacturer Identification

Program the following in STEP 5:

STL	Explanation
C DB 10	Invoke the data block (in this example: DB 10)
L DW 2	Load the diagnostics word "Manufacturer identification" (e.g. "0001H" for ET 200B-16DI)
L KH 0001 !=F	No error?
BEC	Evaluate error in FBx.
JC FBx	

## Diagnostics of the Manufacturer Identification with IM 308-C, continued

**Structure:** The diagnostics word has the following structure for the manufacturer identification (in this example: DW 2):  
**Diagnostics Word**  
**Manufacturer Identification**

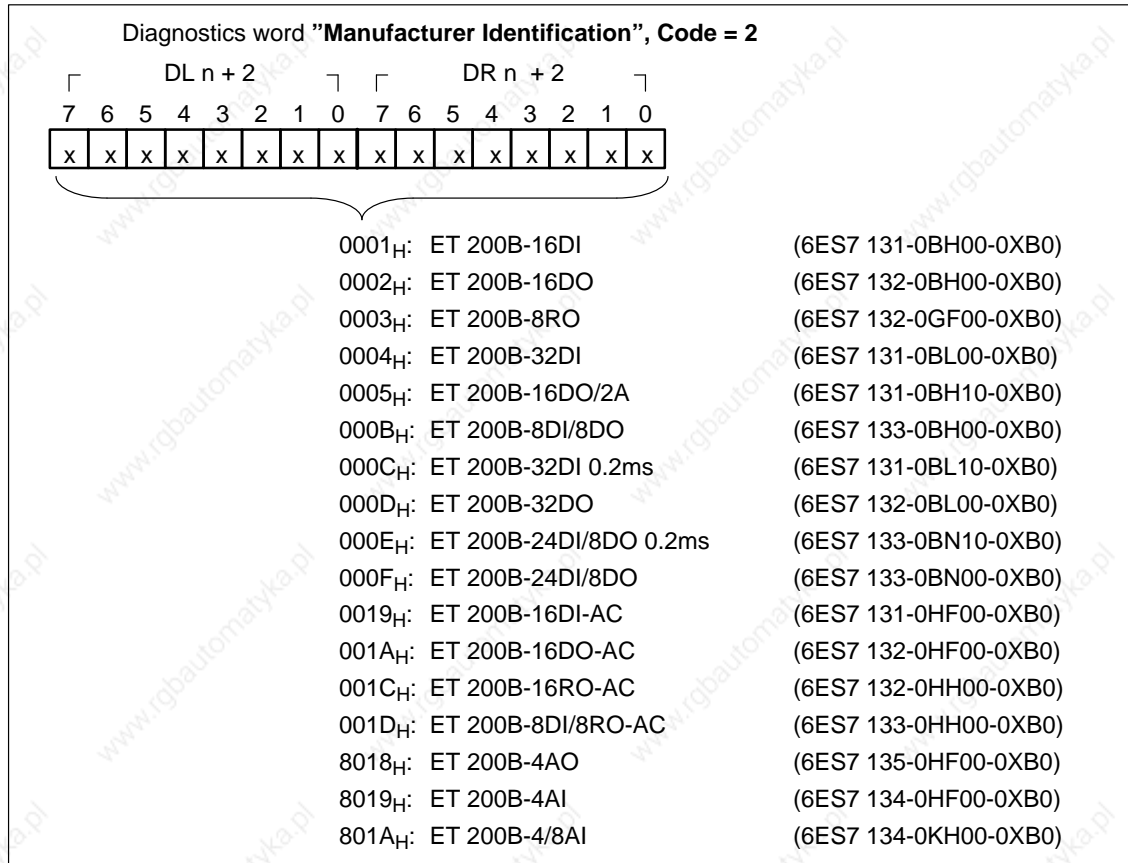

Figure 6-15 Structure of the "Manufacturer Identification" Diagnostics Word

### 6.4.3 Device-Related Diagnostics (Digital ET 200B) in the Case of Operation with IM 308-C

#### Introduction

You can detect faults in inputs and outputs using device-related diagnostics. The header gives information on the length of the device-related diagnostics.

#### Note

Device-related diagnostics are only possible in the case of ET 200B stations with diagnostics capability.

ET 200B stations **without** diagnostics capability contain the value "07H" in the header and the remaining bytes are reserved.

#### Assumption

The station diagnostics of a digital ET 200B module have been requested by the CPU; they are saved in data block DB 10 starting at data word DW n (n = 0). Device-related diagnostics with a length of 7 bytes exist.

Table 6-8 shows the position of the diagnostics data in a data block:

Table 6-8 Position of the Diagnostics Data in a Data Block (Digital ET 200B)

Data Word	DL	DR
DW n	Station status 1	Station status 2
DW n + 1	Station status 3	Master station number
DW n + 2	Manufacturer identification	
DW n + 3	Header	Device-related diagnostics (group diagnostics)
DW n + 4 ... DW n + 6	Reserved	Reserved

n = Word address starting at which the diagnostics data is saved in the DB.

#### Reading Device-Related Diagnostics

Program the following in STEP 5:

STL	Explanation
C DB 10	Invoke the data block (in this example: DB 10)
L DW 3	Load the diagnostics word "Header and device-related diagnostics"
L KH 0700	
!=F	No error?
BEC	
JC FBx	Evaluate error in FBx.

## Device-Related Diagnostics (Digital ET 200B) in the Case of Operation with IM 308-C, continued

### Structure: Diagnostics Word Header and Device-Related Diagnostics

The diagnostics word has the following structure for the header and device-related diagnostics (in this example: DW 3) in the case of digital ET 200B modules:

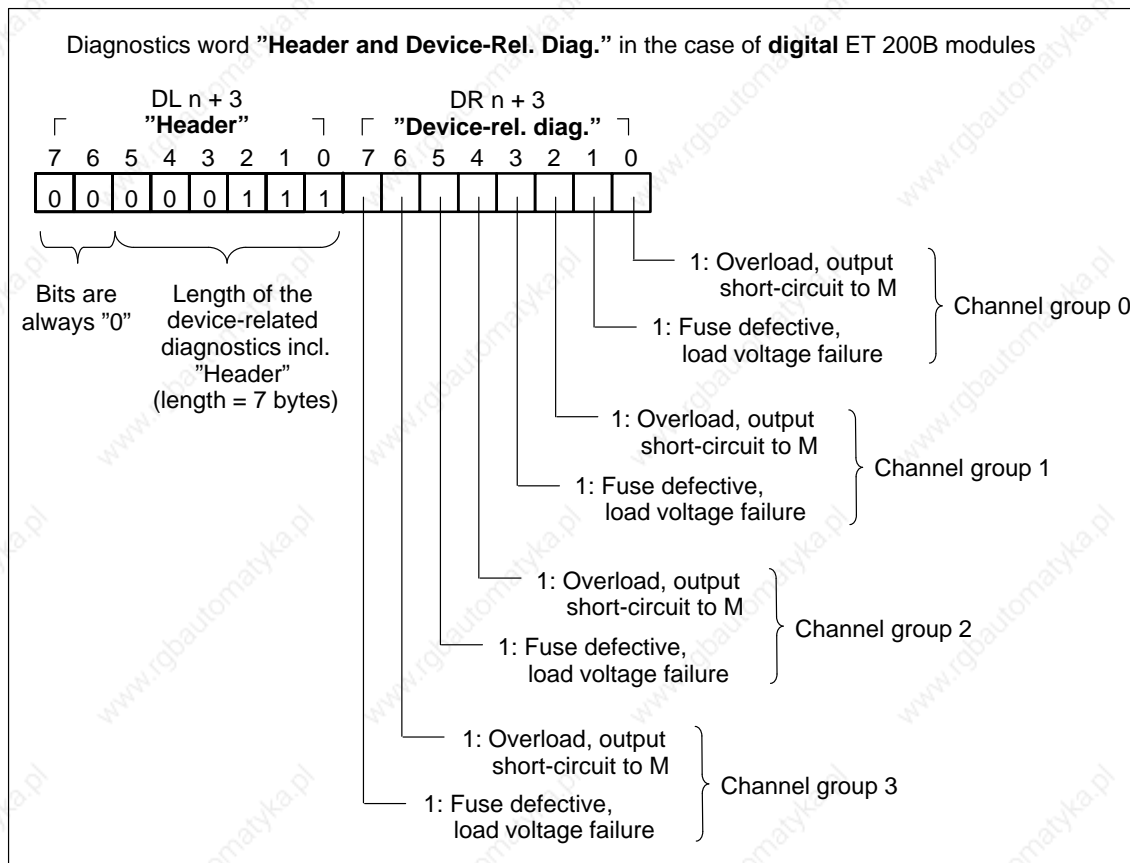

Figure 6-16 Structure of the "Header and Device-Related Diagnostics" Diagnostics Word in the Case of Digital ET 200B Modules"

#### Note

The channel group of a digital ET 200B module always comprises one byte in the S5 address range of the CPU (corresponding to 8 inputs or 8 outputs), irrespective of the galvanic isolation of the module (grouping).

**Example:** ET 200B-16DO/2A (galvanic isolation in groups of 4)

Channel group 0 corresponds to Q0: outputs .0 ... .7.

Potential group 0 corresponds to Q0: outputs .0 ... .3.

## 6.4.4 Device-Related Diagnostics (Analog ET 200B) in the Case of Operation with IM 308-C

### Introduction

Using the device-related diagnostics for an analog ET 200B, you can detect which faults the ET 200B reports. The header gives information on the length of the device-related diagnostics.

### Note

Under analog value representation in Chapter 9 you will find "Supplementary Bits" which will provide you with additional diagnostics information.

### Assumption

The station diagnostics of analog ET 200B modules have been requested by the CPU; they are saved in data block DB 10 starting at data word DW n (n = 0).

Table 6-9 Position of the Diagnostics Data in the Data Block (Analog ET 200B)

Data Word	DL	DR
DW n	Station status 1	Station status 2
DW n + 1	Station status 3	Master station number
DW n + 2	Manufacturer identification	
DW n + 3	Header	Reserved (byte 0)
DW n + 4	Reserved (byte 1)	System-specific diagnostics (byte 2)
DW n + 5	System-specific diagnostics (byte 3)	System-specific diagnostics (byte 4)
DW n + 6	System-specific diagnostics (byte 5)	Input or output channels (byte 6)
DW n + 7	Reserved (byte 7)	Number of channels (byte 8)
DW n + 8	Channel fault (byte 9)	Channel-specific diagnostics (byte 10) <b>Channel 0:</b> 4/8AI, 4AI, 4AO
DW n + 9	Channel-specific diagnostics (byte 11) <b>Channel 1:</b> 4/8AI, 4AI, 4AO	Channel-specific diagnostics (byte 12) <b>Channel 2:</b> 4/8AI, 4AI, 4AO
DW n + 10	Channel-specific diagnostics (byte 13) <b>Channel 3:</b> 4/8AI, 4AI, 4AO	Channel-specific diagnostics (byte 14) <b>Channel 4:</b> 4/8AI
DW n + 11	Channel-specific diagnostics (byte 15) <b>Channel 5:</b> 4/8AI	Channel-specific diagnostics (byte 16) <b>Channel 6:</b> 4/8AI
DW n + 12	Channel-specific diagnostics (byte 17) <b>Channel 7:</b> 4/8AI	Free

n = Word address starting at which the diagnostics data is saved in the DB.



## Device-Related Diagnostics (Analog ET 200B) in the Case of Operation with IM 308-C, continued

### Reading Device-Related Diagnostics

Program the following in STEP 5:

STL	Explanation
C DB 10	Invoke the data block (in this example: DB 10)
L DW 4	Load the diagnostics word "Device-related diagnostics (bytes 1, 2)"
L KH 0700	"No error?"
!=F	Evaluate error in FBx.
BEC	
JC FBx	

Load the appropriate data words of the DB instead of DW 4 for further device-related diagnostics (see Table 6-9).

### Structure: Diagnostics Word Header

The diagnostics word "Header and device-related diagnostics" (in this example: DW 3) has the following structure in the case of analog ET 200B modules:

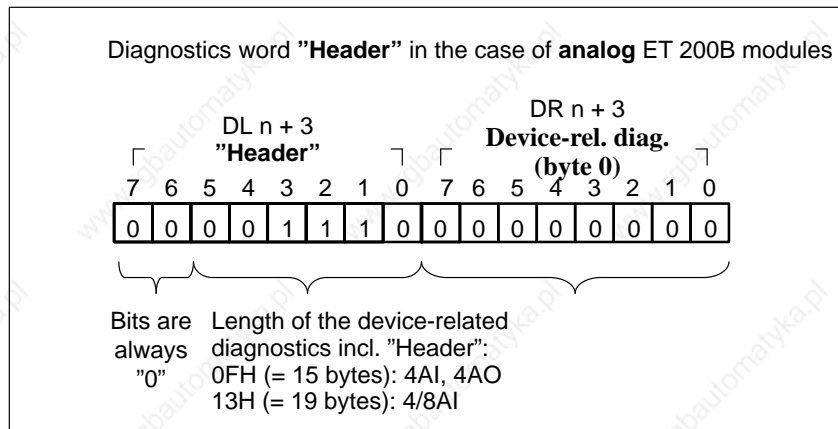

Figure 6-17 Structure of the "Header" Diagnostics Word in the Case of Analog ET 200B Modules

**Structure:** The diagnostics word (in this example: DW 4) has the following structure in the case of analog ET 200B modules:  
**Diagnostics Word Device-Related Diagnostics (Byte 2)**

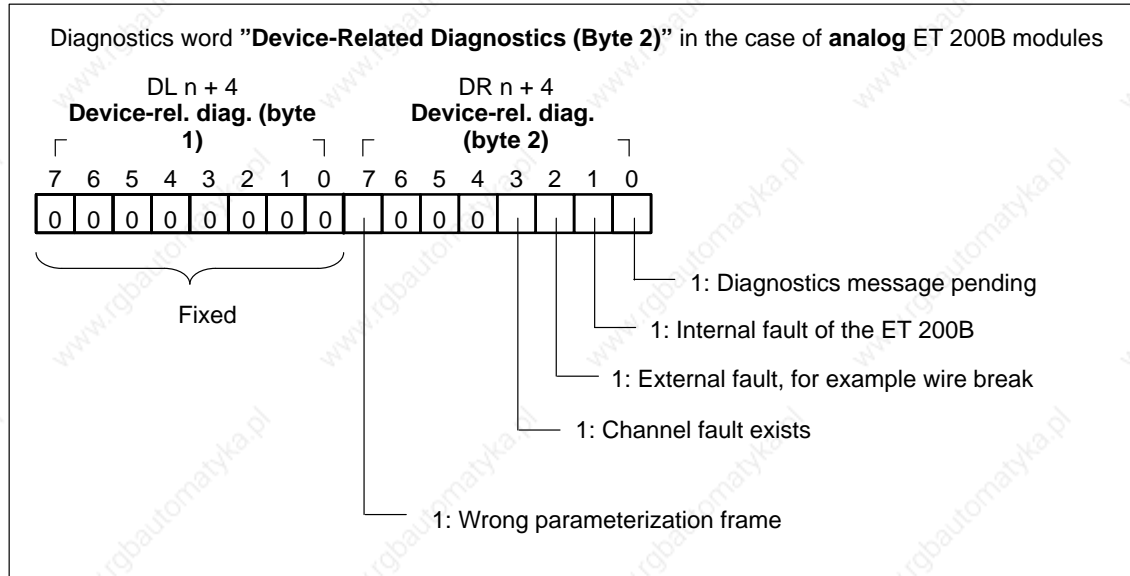

Figure 6-18 Structure of the "Device-Related Diagnostics (Byte 2)" Diagnostics Word in the Case of Analog ET 200B Modules

**Structure:** The diagnostics word (in this example: DW 5) has the following structure in the case of analog ET 200B modules:  
**Diagnostics Word Device-Related Diagnostics (Bytes 3, 4)**

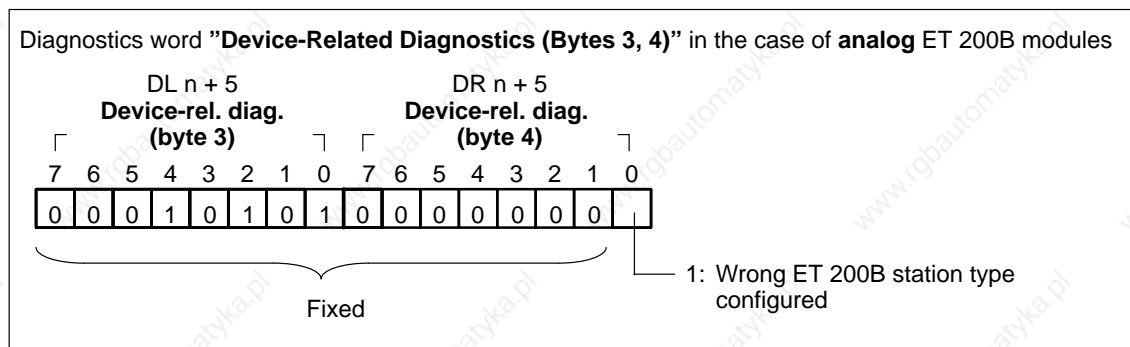

Figure 6-19 Structure of the "Device-Related Diagnostics (Bytes 3, 4)" Diagnostics Word in the Case of Analog ET 200B Modules

## Device-Related Diagnostics (Analog ET 200B) in the Case of Operation with IM 308-C, continued

**Structure:** The diagnostics word (in this example: DW 6) has the following structure in the case of analog ET 200B modules:  
**Diagnostics Word**  
**Device-Related**  
**Diagn. (Bytes 5, 6)**

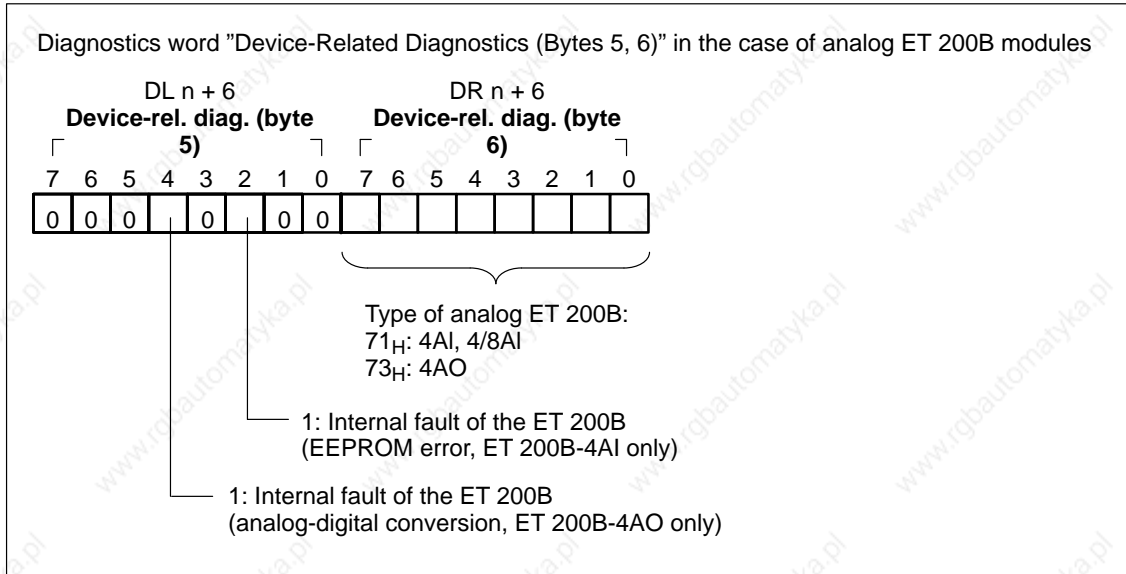

Figure 6-20 Structure of the "Device-Related Diagnostics (Bytes 5, 6)" Diagnostics Word in the Case of Analog ET 200B Modules

**Structure:** The diagnostics word (in this example: DW 7) has the following structure in the case of analog ET 200B modules:  
**Diagnostics Word**  
**Device-Related**  
**Diagn. (Bytes 7, 8)**

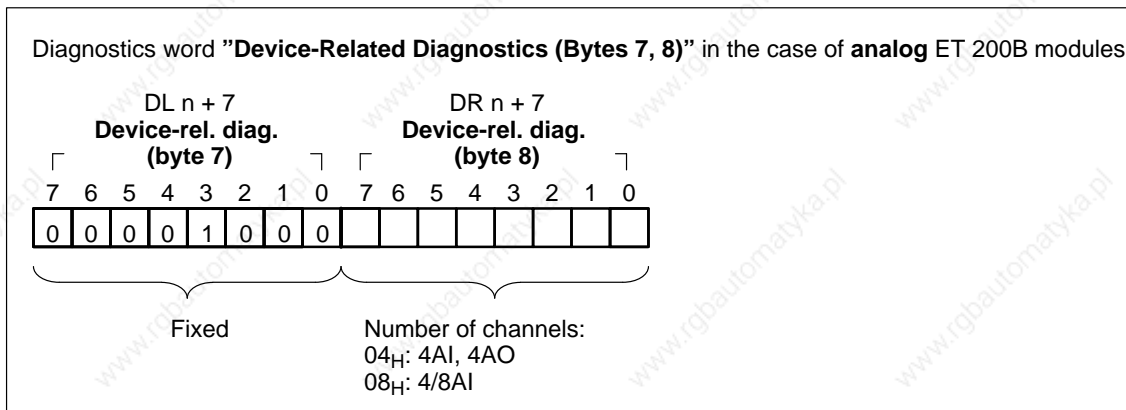

Figure 6-21 Structure of the "Device-Related Diagnostics (Bytes 7, 8)" Diagnostics Word in the Case of Analog ET 200B Modules

**Structure:  
Diagnostics Word  
Device-Related  
Diagnostics  
(Bytes 9, 10)**

The diagnostics word (in this example: DW 8) has the following structure in the case of analog ET 200B modules:

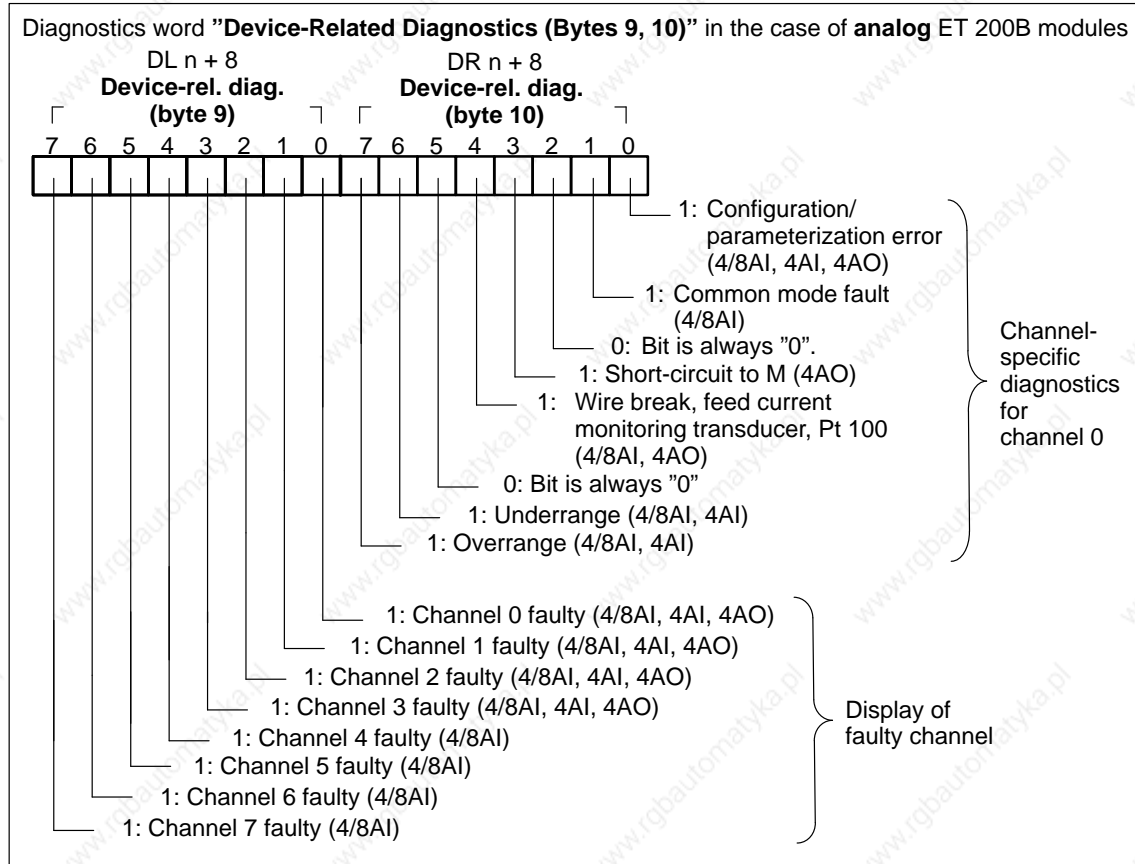

Figure 6-22 Structure of the "Header and Device-Related Diagnostics (Bytes 9, 10)" Diagnostics Word in the Case of Analog ET 200B Modules

**Structure:  
Diagnostic Word  
Device-Related  
Diagnostics  
(Bytes 11, 12)**

Diagnostics bytes 11 and 12 (in this example: DW 9) have the same structure as byte 10; they describe the channel-specific diagnostics for channels 1 and 2.

## Device-Related Diagnostics (Analog ET 200B) in the Case of Operation with IM 308-C, continued

**Structure:** The diagnostics word (in this example: DW 8) has the following structure in the case of analog ET 200B modules:  
**Diagnostics Word Device-Related Diagnostics (Bytes 13, 14)**

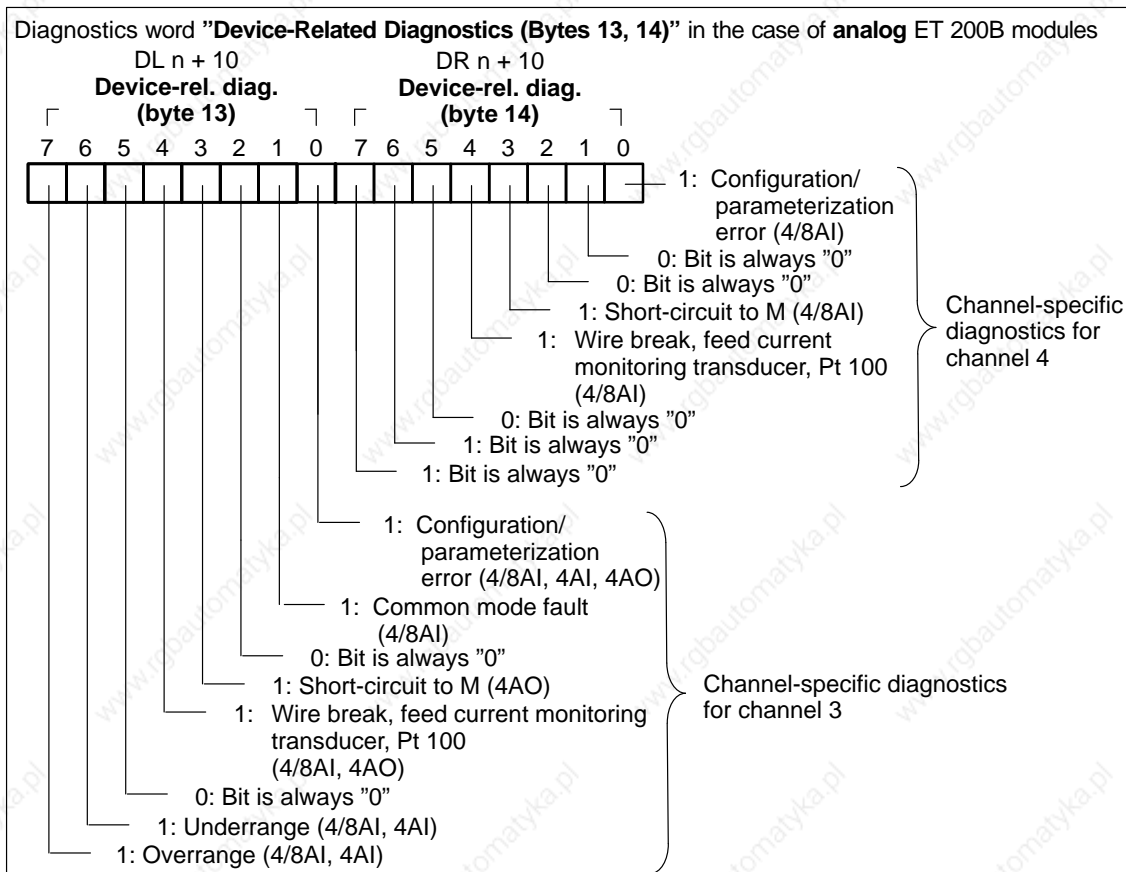

Figure 6-23 Structure of the "Header and Device-Related Diagnostics (Bytes 13, 14)" Diagnostics Word in the Case of Analog ET 200B Modules

**Structure:** Diagnostics bytes 15 to 17 have the same structure as byte 14; they describe the channel-specific diagnostics for channels 5 to 7 of the ET 200B-4/8AI.  
**Diagnostic Word Device-Related Diagnostics (Bytes 15, 16, 17)**

# General Technical Specifications

# 7

## **In this Chapter**

This chapter contains the technical specifications.

The general technical specifications contain the standards and test values all ET 200B modules comply with and the test criteria for which all modules were checked.

## 7.1 General Technical Specifications

<p><b>Climatic environ. conditions acc. to IEC 1131-2</b></p> <p>Operating temperature</p> <ul style="list-style-type: none"> <li>Preferred installation (= horizontal installation on a vertical wall: see Figure 3-5) 0 to +60 °C (32 to 140 °F)</li> <li>Other installation positions 0 to +40 °C (32 to 104 °F) (Air intake temperature, measured at the bottom of the module)</li> </ul> <p>Storage/transport temperature -40 to +70 °C (-40 to 158 °F)</p> <p>Relative humidity to DIN 40040 15 to 95 % (indoor), no condensation</p> <p>Atmospheric pressure</p> <ul style="list-style-type: none"> <li>Operating 795 to 1080 hPa</li> <li>Storage/transport 660 to 1080 hPa</li> </ul> <p>Pollutants</p> <ul style="list-style-type: none"> <li>SO<sub>2</sub> ≤ 0.5 ppm (rel. humidity ≤ 60 %, no condensation)</li> <li>H<sub>2</sub>S ≤ 0.1 ppm (rel. humidity ≤ 60 %, no condensation)</li> </ul>	<p><b>Electromagnetic compatibility (EMC)/noise immunity</b></p> <p>Static electricity to IEC 801-2 Discharge to all parts that are accessible to the operator during normal operation</p> <ul style="list-style-type: none"> <li>Test voltage 8 kV air discharge 4 kV contact discharge (relative humidity 30 to 95%)</li> </ul> <p>Electromagnetic fields to IEC 801-3 Field strength 10 V/m</p> <p>Fast transient burst to IEC 801-4, Class III</p> <ul style="list-style-type: none"> <li>Digital input/output module for V = 24 V 2 kV for V &gt; 24 V 2 kV</li> <li>Analog input/output module 2 kV</li> <li>Communications interface 2 kV</li> </ul>						
<p><b>Mechanical environmental conditions</b></p> <p>Vibration<sup>1</sup> tested to IEC 68-2-6</p> <ul style="list-style-type: none"> <li>10 Hz ≤ f &lt; 57 Hz Const. amplitude 0.075 mm</li> <li>57 Hz ≤ f &lt; 150 Hz Const. acceleration 1g</li> <li>Mode of vibration Frequency sweeps with a rate of change of 1 octave/min.</li> <li>Period of oscillation 10 frequency sweeps per axis in each of the 3 perpendicular axes</li> <li>Operating conditions In accordance with IEC 1131-2</li> </ul> <p>Shock<sup>1</sup> tested to IEC 68-2-27</p> <ul style="list-style-type: none"> <li>Type of shock Semi-sinusoidal</li> <li>Strength of shock 15 g peak value, 11 ms duration</li> <li>Direction of shock 2 shocks in each of the 3 perpendicular axes</li> </ul> <p>Drop and topple to IEC 68-2-31</p> <ul style="list-style-type: none"> <li>Tested with Height of fall 100 mm (3.90 in.)</li> </ul>	<p><b>IEC/VDE safety information</b></p> <p>Degree of protection to IEC 529</p> <ul style="list-style-type: none"> <li>Type IP 20</li> <li>Class I to IEC 536</li> </ul> <p>Insulation rating</p> <ul style="list-style-type: none"> <li>Between electrically independent circuits and circuits connected to a central grounding point to DIN VDE 0160 (05.1988) and IEC 1131-2</li> <li>Between all circuits and central grounding point (standard sectional rail) to DIN VDE 0160 (05.1988) and IEC 1131-2</li> </ul> <p>Test voltage for a nominal voltage V<sub>input</sub> of the circuits (AC/DC)</p> <table border="0"> <tr> <td>V<sub>input</sub> = 0 to 50 V</td> <td>500 V DC</td> </tr> <tr> <td>V<sub>input</sub> = 50 to 125 V</td> <td>1250 V AC</td> </tr> <tr> <td>V<sub>input</sub> = 125 to 250 V</td> <td>1500 V AC</td> </tr> </table> <p>Radio interference suppression to VDE 0871</p> <ul style="list-style-type: none"> <li>Limit class A</li> </ul>	V <sub>input</sub> = 0 to 50 V	500 V DC	V <sub>input</sub> = 50 to 125 V	1250 V AC	V <sub>input</sub> = 125 to 250 V	1500 V AC
V <sub>input</sub> = 0 to 50 V	500 V DC						
V <sub>input</sub> = 50 to 125 V	1250 V AC						
V <sub>input</sub> = 125 to 250 V	1500 V AC						

<sup>1</sup> Vibrations and shocks permanently reaching the specified values as well as bumps must be prevented by adequate measures.

# Digital Modules

# 8

## In this Chapter

This chapter contains the technical specifications of the ET 200B digital modules. The chapter is broken down into sections for

- 24 V DC digital modules
- 120/230 V AC V digital modules



## 8.1 Digital Modules

**Introduction** The tables below provide an overview of the digital modules of the ET 200B.

**List of Electronics Blocks** The following types of digital electronics blocks are available:

Table 8-1 ET 200B Digital Electronics Blocks (24 V DC)

Electronics Block	Order No.	Description
ET 200B-16DI	6ES7 131-0BH00-0XB0	Inputs: 16 × DC 24 V (3 ms)
ET 200B-32DI	6ES7 131-0BL00-0XB0	Inputs: 32 × DC 24 V (3 ms)
ET 200B-32DI 0.2ms	6ES7 131-0BL10-0XB0	Inputs: 32 × DC 24 V (0,2 ms)
ET 200B-16DO	6ES7 132-0BH00-0XB0	Outputs: 16 × DC 24 V (0,5 A/2 A)
ET 200B-16DO/2A	6ES7 132-0BH10-0XB0	Outputs: 16 × DC 24 V (2 A)
ET 200B-32DO	6ES7 132-0BL00-0XB0	Outputs: 32 × DC 24 V (0,5 A)
ET 200B-8DI/8DO	6ES7 133-0BH00-0XB0	Inputs: 8 × DC 24 V (3 ms) Outputs: 8 × DC 24 V (0,5 A)
ET 200B-24DI/8DO	6ES7 133-0BN00-0XB0	Inputs: 24 × DC 24 V (3 ms) Outputs: 8 × DC 24 V (0,5 A)
ET 200B-24DI/8DO 0.2ms	6ES7 133-0BN10-0XB0	Inputs: 24 × DC 24 V (0,2 ms) Outputs: 8 × DC 24 V (0,5 A)
ET 200B-8RO	6ES7 132-0GF00-0XB0	Outputs: 8 × REL. DC 24 ... 60 V
ET 200B-16DI-AC	6ES7 131-0HF00-0XB0	Inputs: 16 x AC 120/230 V
ET 200B-16DO-AC	6ES7 132-0HF00-0XB0	Outputs: 16 x AC 120/230 V (0,5 A)
ET 200B-16RO-AC	6ES7 132-0HH00-0XB0	Outputs: 16 x REL. AC 120/230 V/DC 24 ... 150 V
ET 200B-8DI/8RO-AC	6ES7 133-0HH00-0XB0	Inputs: 8 x AC 120/230 V Outputs: 8 x REL. AC 120/230 V/DC 24 ... 150 V

**List of Terminal Blocks**

The following types of digital terminal blocks are available:

Table 8-2 ET 200B Digital Terminal Blocks

Terminal Block	Order No.	Description
TB1/DC	6ES7 193-0CA10-0XA0	16-channel, screw-type terminal, 3-tier
TB1-4/DC	6ES7 193-0CA20-0XA0	16-channel, screw-type terminal, 4-tier
TB2/DC	6ES7 193-0CB10-0XA0	32-channel, screw-type terminal, 3-tier
TB2-4/DC	6ES7 193-0CB20-0XA0	32-channel, screw-type terminal, 4-tier
TB3/DC	6ES7 193-0CA30-0XA0	16-channel, spring-loaded terminal
TB4/DC	6ES7 193-0CB30-0XA0	32-channel, spring-loaded terminal
TB6/AC	6ES7 193-0CC10-0XA0	16-channel, screw-type terminal, 3-tier

### 8.1.1 Terminal Blocks TB1/DC (6ES7 193-0CA10-0XA0), TB1-4/DC (6ES7 193-0CA20-0XA0) and TB3/DC (6ES7 193-0CA30-0XA0)

#### Dimension Drawing TB1/DC

Dimension drawing: Terminal block TB1/DC (screw-type terminal, 3-tier)

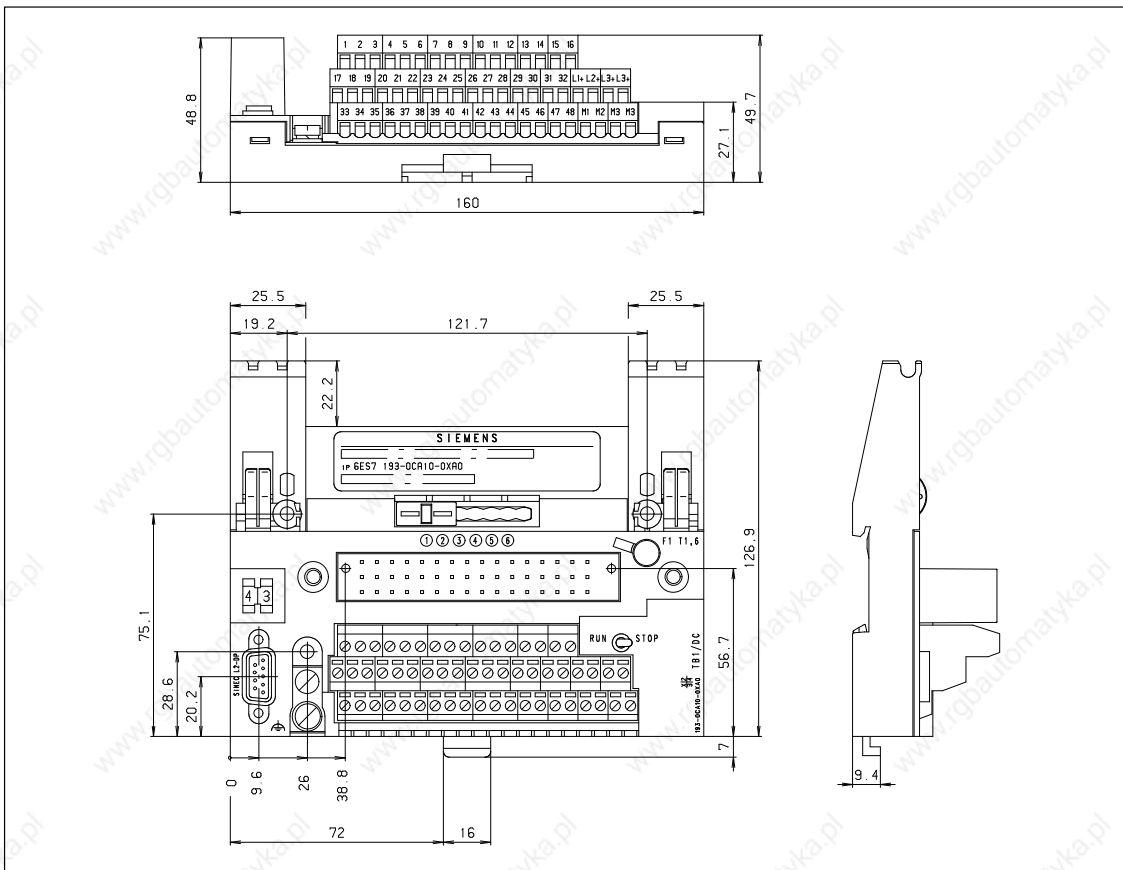

Figure 8-1 Dimension Drawing: Terminal Block TB1/DC (Screw-Type Terminal, 3-Tier)

**Dimension  
Drawing TB1-4/DC**

Dimension drawing: Terminal block TB1-4/DC (screw-type terminal, 4-tier)

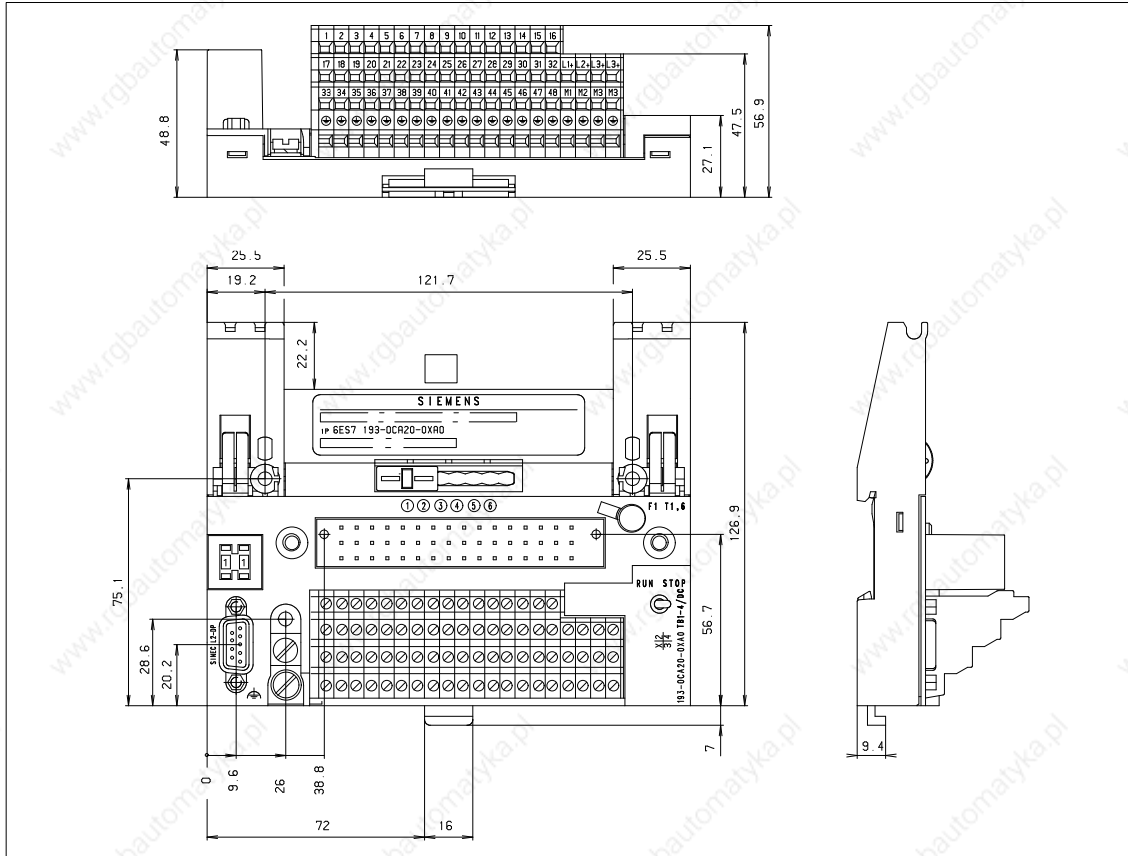

Figure 8-2 Dimension Drawing: Terminal Block TB1-4/DC (Screw-Type Terminal, 4-Tier)

**Terminal Blocks TB1/DC (6ES7 193-0CA10-0XA0), TB1-4/DC (6ES7 193-0CA20-0XA0) and TB3/DC (6ES7 193-0CA30-0XA0), continued**

**Dimension Drawing TB3/DC**

Dimension Drawing: Terminal block TB3/DC (spring-loaded terminal)

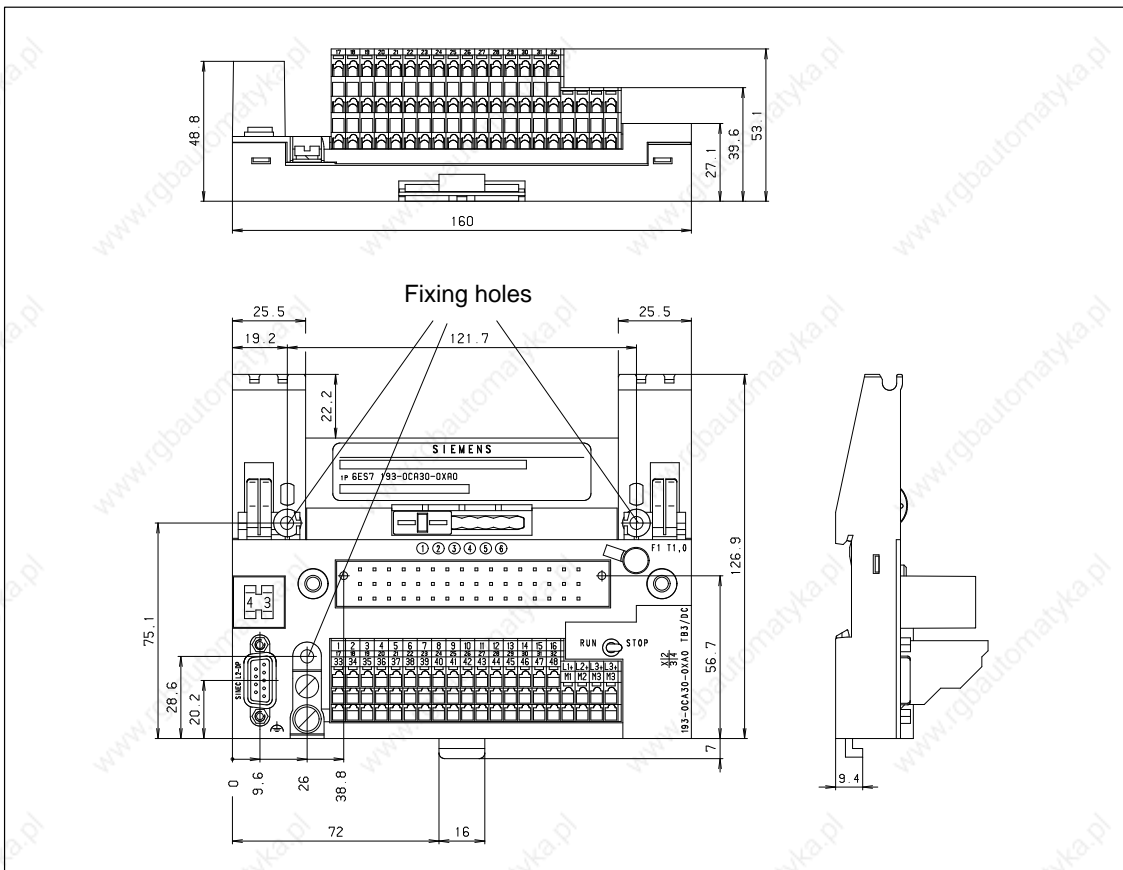

Figure 8-3 Dimension Drawing: Terminal Block TB3/DC (Spring-Loaded Terminal)

**Dimension Drawing TB with Bus Connector (6ES7 ...)**

Dimension drawing: Side elevation TB1/DC, TB1-4/DC or TB3/DC with SINEC L2 bus connector (6ES7 ...)

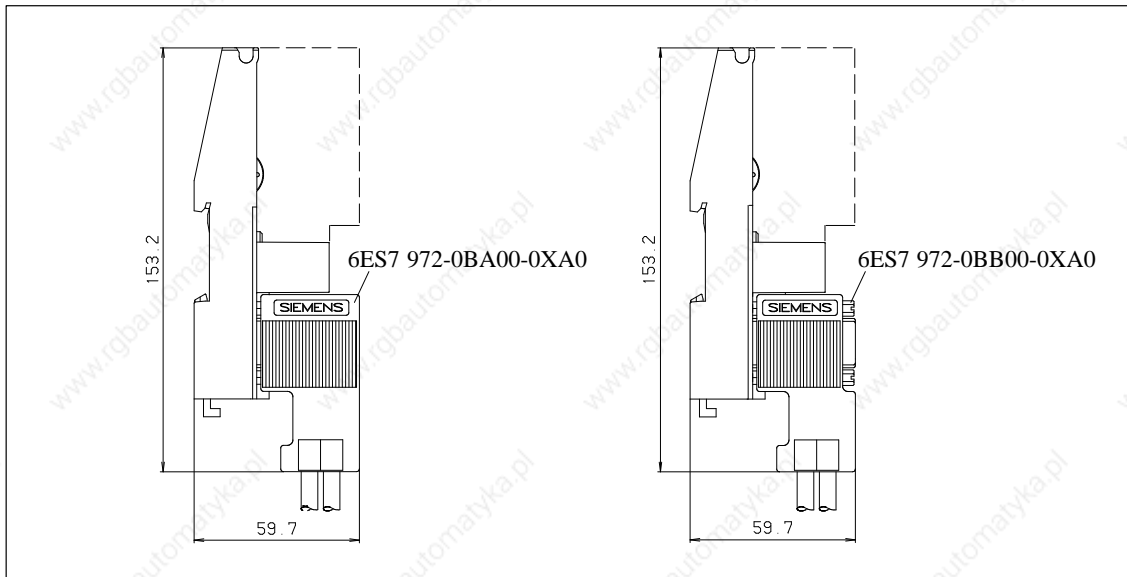

Figure 8-4 Dimension Drawing: Side Elevation of Terminal Blocks, TB1/DC, TB1-4/DC and TB3/DC with SINEC L2 Bus Connector (6ES7 972-0BA00-0XA0 and 6ES7 972-0BB00-0XA0)

**Dimension Drawing TB with Bus Connector (6ES5 ...)**

Dimension drawing: Side elevation TB1/DC, TB1-4/DC or TB3/DC with SINEC L2 bus connector (6ES5 ...)

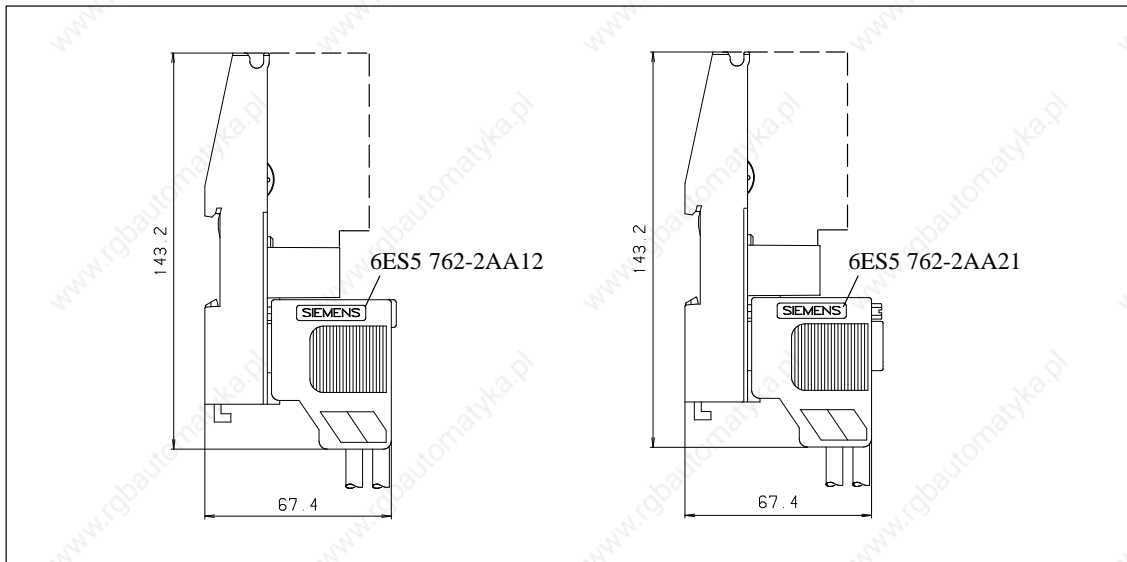

Figure 8-5 Dimension Drawing: Side Elevation of Terminal Blocks TB1/DC, TB1-4/DC and TB3/DC with SINEC L2 Bus Connector (6ES5 762-2AA12 and 6ES5 762-2AA21)

### 8.1.2 Terminal Blocks TB2/DC (6ES7 193-0CB10-0XA0), TB2-4/DC (6ES7 193-0CB20-0XA0) and TB4/DC (6ES7 193-0CB30-0XA0)

#### Dimension Drawing TB2/DC

Dimension Drawing: Terminal Block TB2/DC (screw-type terminal, 3-tier)

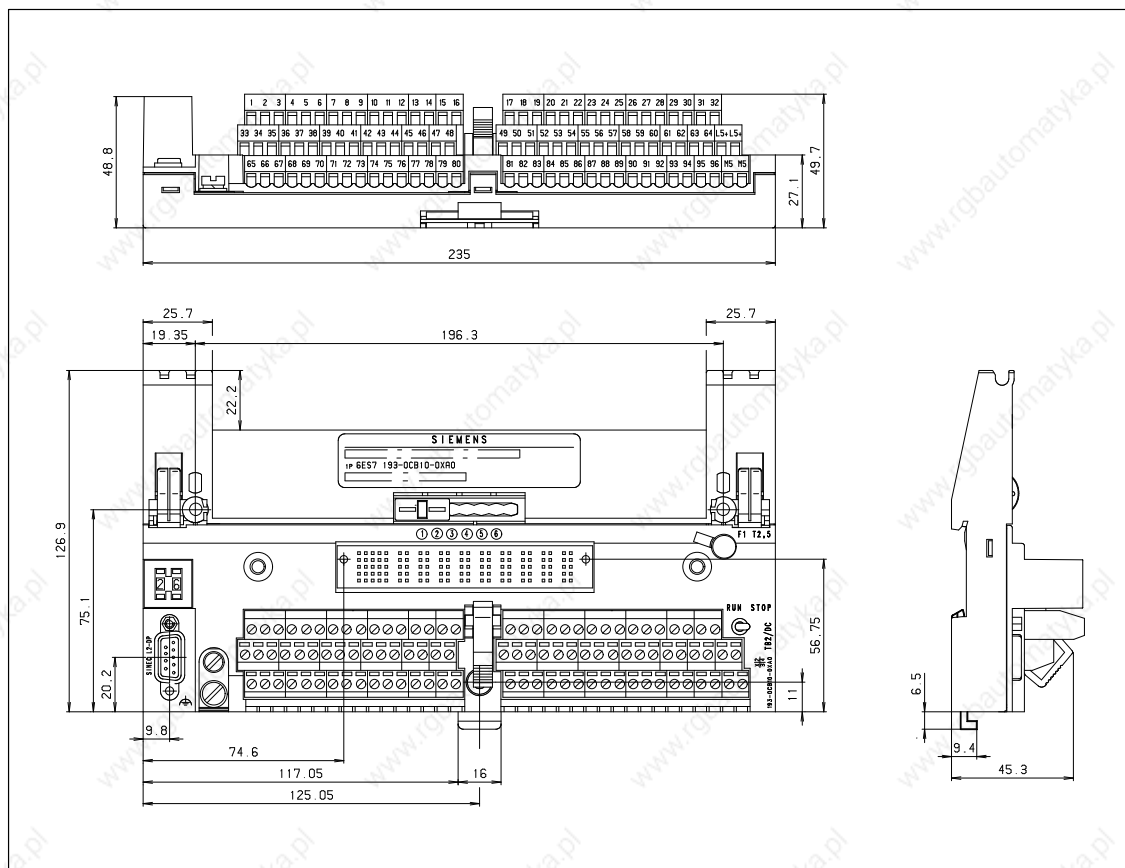

Figure 8-6 Dimension Drawing: Terminal Block TB2/DC (screw-type terminal, 3-tier)





**Terminal Blocks TB2/DC (6ES7 193-0CB10-0XA0), TB2-4/DC (6ES7 193-0CB20-0XA0) and TB4/DC (6ES7 193-0CB30-0XA0), continued**

**Dimension Drawing TB4/DC**

Dimension Drawing: TB4/DC (Spring-loaded terminal)

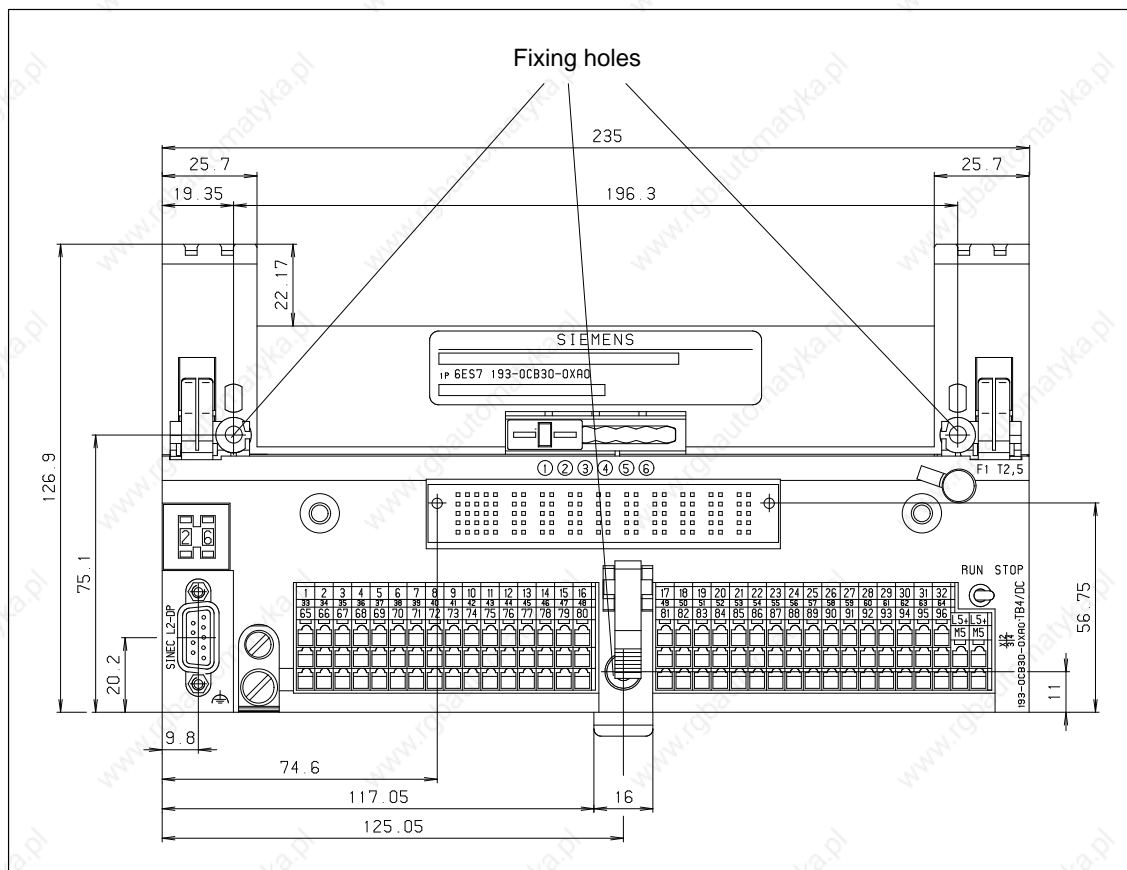

Figure 8-8 Dimension Drawing: TB4/DC (Spring-loaded terminal)

**Dimension Drawing TB with Bus Connector (6ES7 ...)**

Dimension drawing: Side elevation TB2/DC, TB2-4/DC or TB4/DC with SINEC L2 bus connector (6ES7 ...)

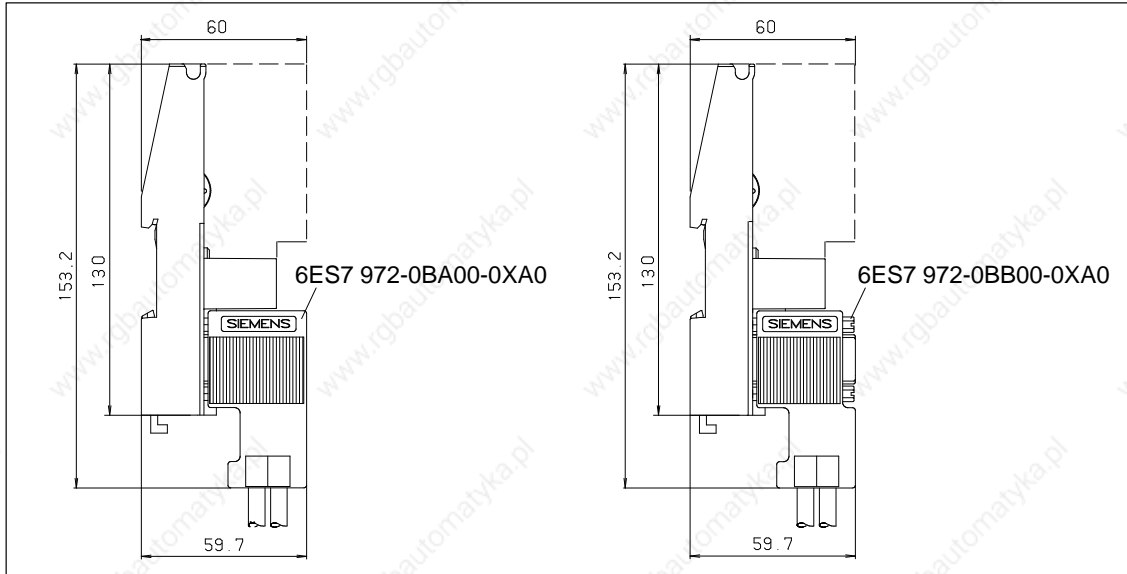

Figure 8-9 Dimension Drawing: Side Elevation of Terminal Blocks TB2/DC, TB2-4/DC and TB4/DC with SINEC L2 Bus Connector (6ES7 972-0BA00-0XA0 and 6ES7 972-0BB00-0XA0)

**Dimension Drawing TB with Bus Connector (6ES5 ...)**

Dimension drawing: Side elevation TB2/DC, TB2-4/DC or TB4/DC with SINEC L2 bus connector (6ES5 ...)

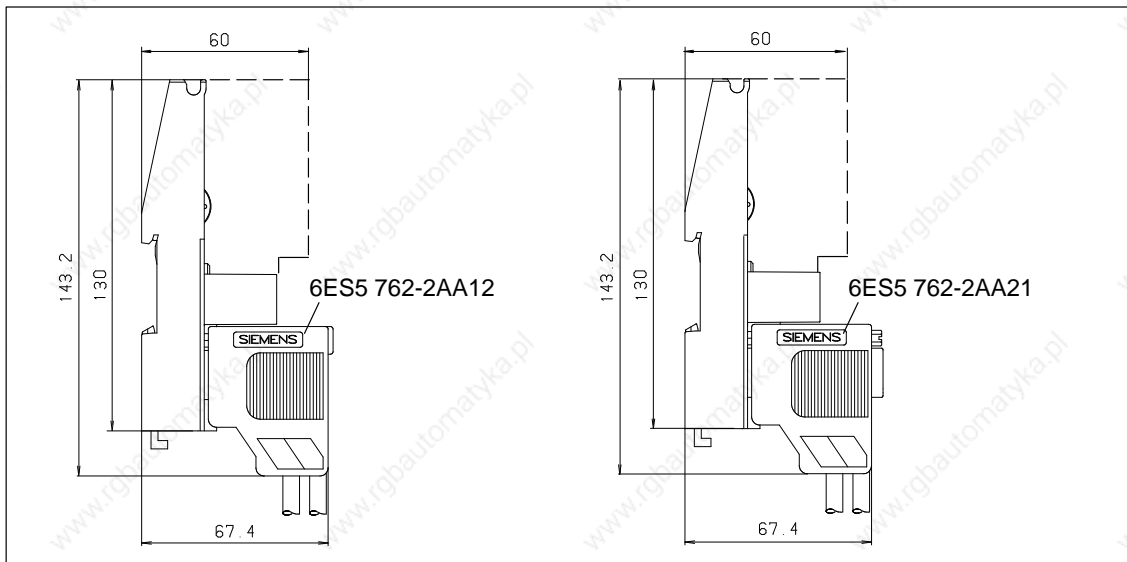

Figure 8-10 Dimension Drawing: Side Elevation of Terminal Blocks TB2/DC, TB2-4/DC and TB4/DC with SINEC L2 Bus Connector (6ES5 762-2AA12 and 6ES5 762-2AA21)

### 8.1.3 Terminal Block TB6/AC (6ES7 193-0CC10-0XA0)

**Dimension Drawing TB6/AC**

Dimension Drawing: Terminal Block TB6/AC (screw-type terminal, 3-tier)

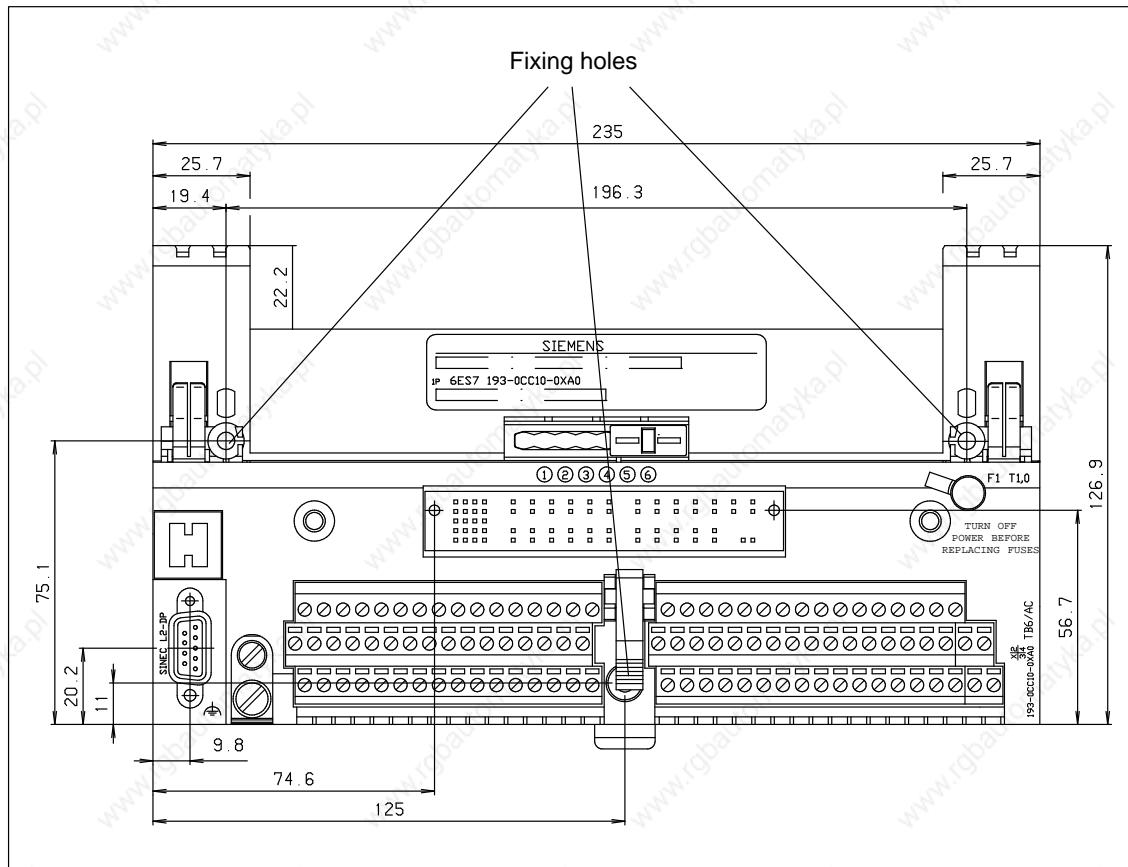

Figure 8-11 Dimension Drawing: Terminal Block TB6/AC (screw-type terminal, 3-tier)

**Dimension Drawing  
TB6/AC with Bus  
Connector  
(6ES7 ...)**

Dimension drawing: Side elevation TB6/AC with SINEC L2 bus connector

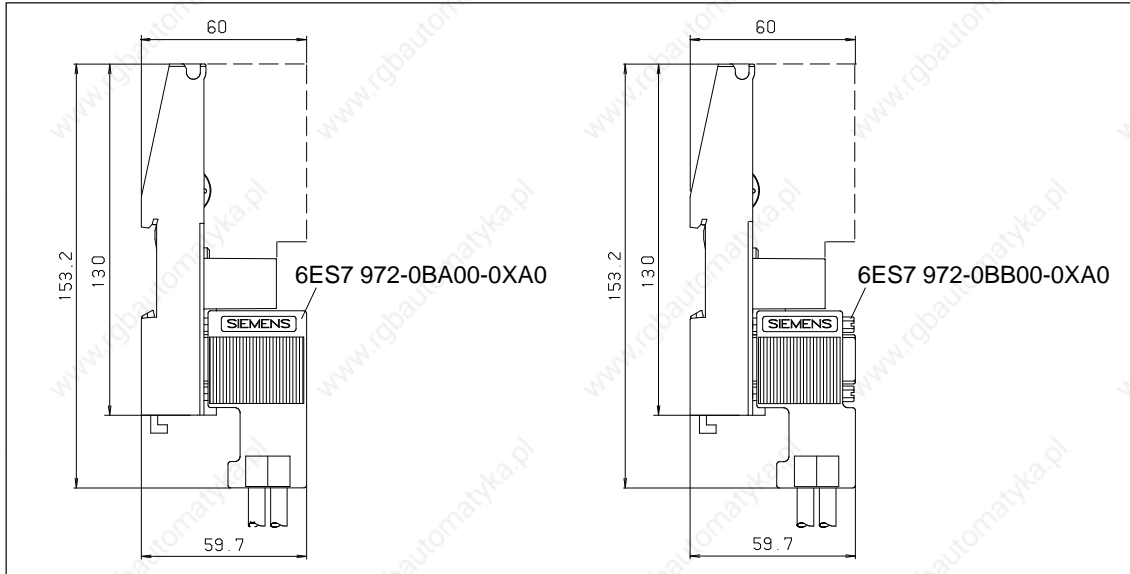

Figure 8-12 Dimension Drawing: Side Elevation of Terminal Block TB6/AC with SINEC L2 Bus Connector (6ES7 972-0BA00-0XA0 and 6ES7 972-0BB00-0XA0)

**Dimension Drawing  
TB6/AC with Bus  
Connector  
(6ES5 ...)**

Dimension drawing: Side elevation TB6/AC with SINEC L2 bus connector

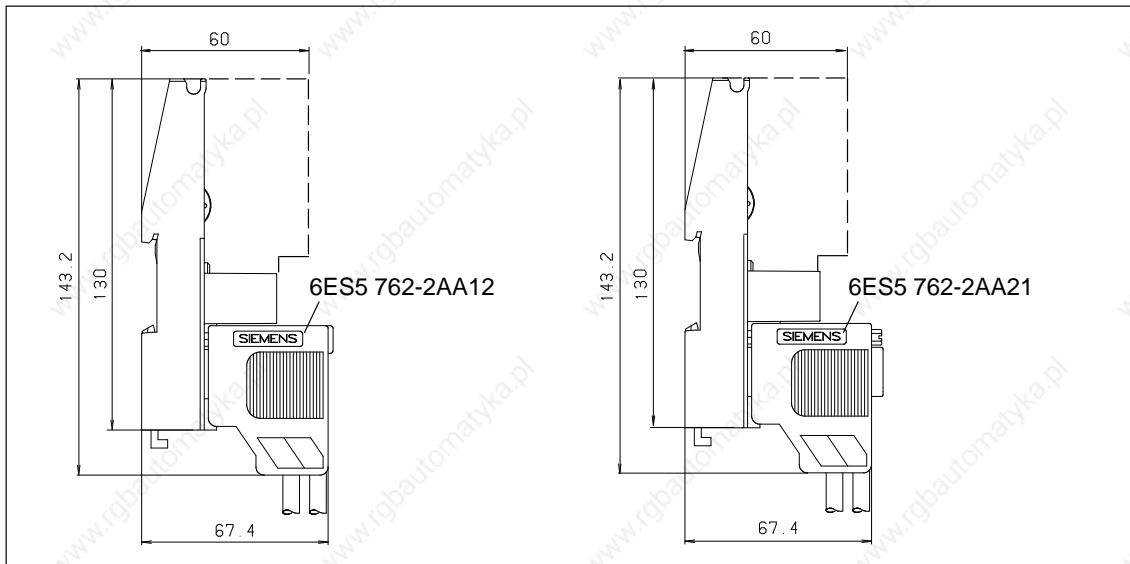

Figure 8-13 Dimension Drawing: Side Elevation of Terminal Block TB6/AC with SINEC L2 Bus Connector (6ES5 762-2AA12 and 6ES5 762-2AA21)

### 8.1.4 Electronics Block ET 200B-16DI (6ES7 131-0BH00-0XB0)

**Characteristics**

The ET 200B 16DI electronics block has the following features

- 16 inputs, non-floating
- Input voltage: 24 V DC
- Suitable for switches and 2/3-wire proximity switches (BEROs).

**Dimension Drawing**

Dimension drawing for ET 200B-16DI:

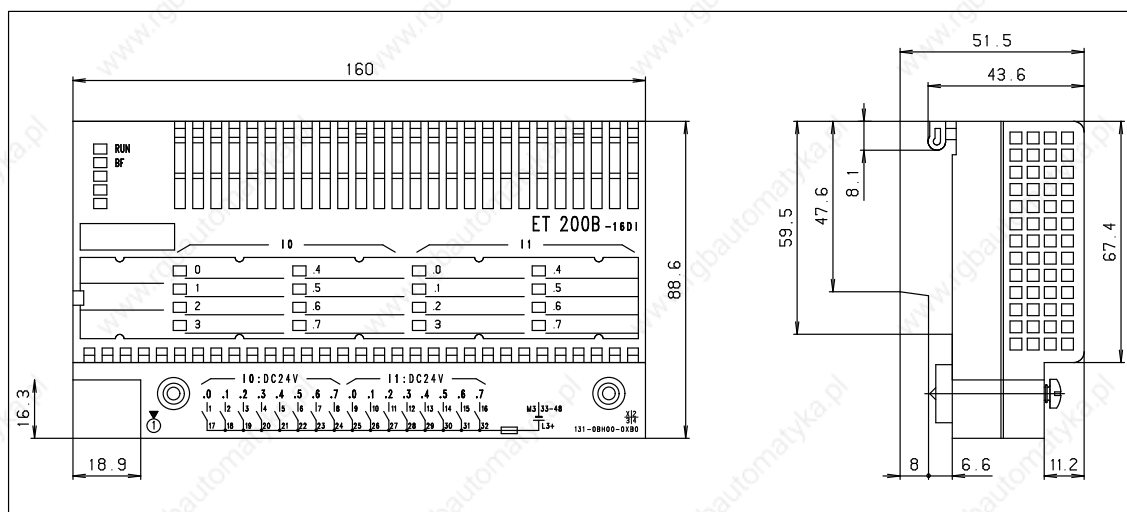

Figure 8-14 Dimension Drawing: ET 200B-16DI (6ES7 131-0BH00-0XB0)



## Electronics Block ET 200B-16DI (6ES7 131-0BH00-0XB0), continued

**Schematic Circuit Diagram** Simplified diagram of the potential for the ET 200B-16DI and TB1-4/DC:

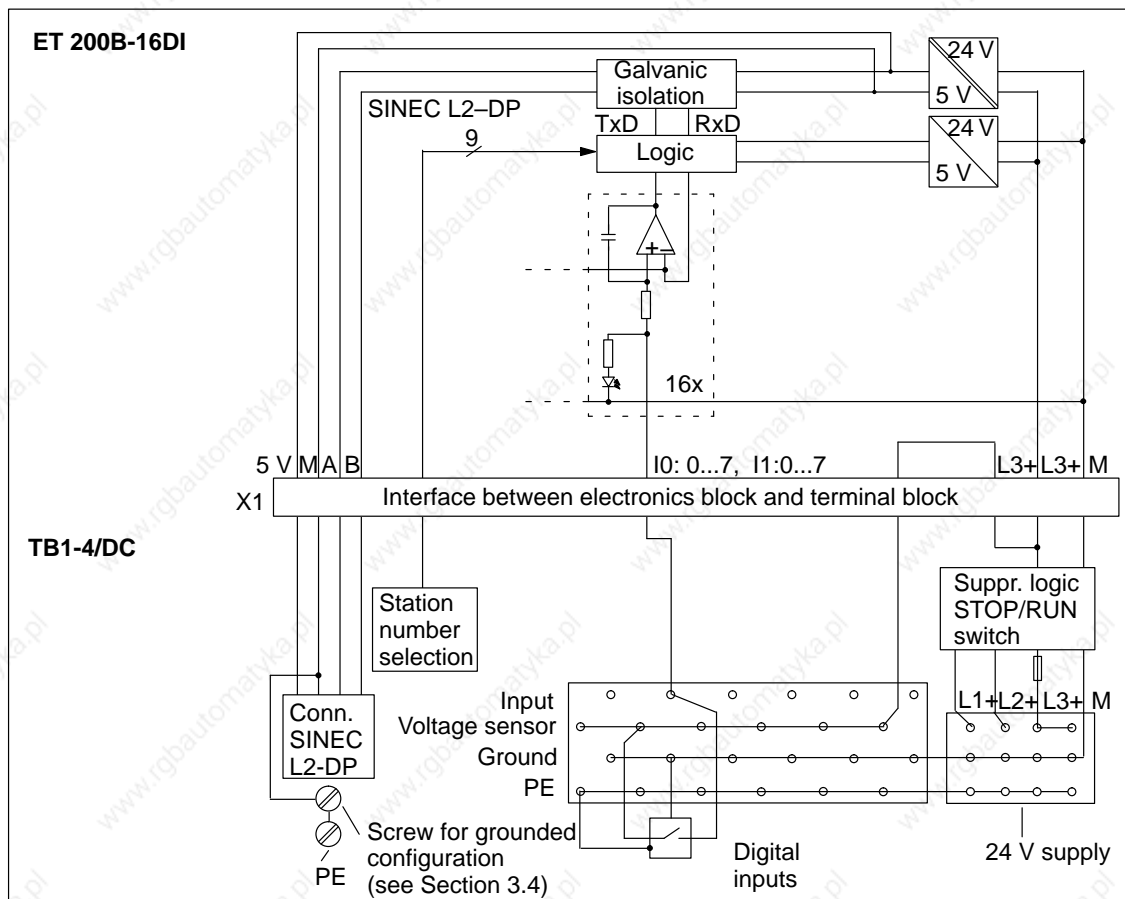

Figure 8-16 Schematic Circuit Diagram: ET 200B-16DI (6ES7 131-0BH00-0XB0) and TB1-4/DC

### Note

The connection terminals for PE on the 4-tier terminal block are not connected to the PE terminal of the TB1-4/DC terminal block.

## Terminal Assignments

The ET 200B-16DI can be plugged into the TB1/DC, TB1-4/DC or TB3/DC.

Table 8-3 contains the terminal assignments of the terminal blocks for the ET 200B-16DI:

Table 8-3 Terminal Assignments of Terminal Blocks TB1/DC, TB2-4/DC and TB3/DC for the ET 200B-16DI (6ES7 131-0BH00-0XB0)

Terminal	Assignment
1 to 8	I0: Inputs .0 to .7
9 to 16	I1: Inputs .0 to .7
17 to 32	24 V (sensor supply, internally jumpered)
33 to 48	Ground (sensor supply, internally jumpered)
20 terminals  (TB1-4/DC only)	PE (internally jumpered, but not connected to PE screw) (TB1-4/DC only)
L1+	Unassigned
L2+	Unassigned
L3+	Power supply of the internal logic <b>and</b> 24 V sensor supply
L3+	Power supply of the internal logic <b>and</b> 24 V sensor supply
M1	Unassigned
M2	Unassigned
M3	Ground connection of the internal logic <b>and</b> sensor supply
M3	Ground connection of the internal logic <b>and</b> sensor supply

### Note

L3+ and terminals 17 to 32 are connected to each other, as are M1, M2, M3 and terminals 33 to 48.



## Electronics Block ET 200B-16DI (6ES7 131-0BH00-0XB0), Continued

Technical specifications		Inputs	
Baud rates	9.6/19.2/93.75/187.5/500/ 1500/3000*/6000*/ 12000* kbps	Number of inputs	16
Bus protocol	DP standard	Galvanic isolation to internal electronic circuits	No
FREEZE capability	Yes+	Input voltage	
Galvanic isolation to SINEC L2-DP	Yes	• Rated value	24 V DC
Power losses	Typ. 2.5 W	• For "0" signal	- 30 V to 5 V
Weight (EB and TB)	Approx. 600 g (21 oz.)	• For "1" signal	13 V to 30 V
Dimensions (EB and TB: W × H × D)	160 × 130 × 60 mm (6.24 x 5.07 x 2.34 in.)	Input current for "1" signal	Typ. 4 mA at 24 V Min. 2 mA
<b>Diagnostics functions</b>		Delay of inputs	2.0 to 3.5 ms
Voltage monitoring	Green "RUN" LED	Connection of 2-wire BERO	Possible
Bus monitoring SINEC L2-DP	Red "BF" LED	• Quiescent current	≤ 1.5 mA
Status of inputs	Green LEDs	Connection of mechanical switches	Possible
<b>Supply voltage for inputs, sensor supply and internal logic</b>		Wire lengths of the sensors	
Supply voltage (L3+)		• Unshielded	Max. 100 m (328 ft.)
• Rated value	24 V DC	* Only relevant when operating with the IM 308-C.	
• Permissible range	18.5 to 30.2 V		
• Value for $t < 0.5$ s	35 V		
Current consumption from L3+			
• Logic	Typ. 70 mA		
• Sensors	Max. 500 mA		
$I^2t$ (for inrush current)	≤ 0.05 A <sup>2</sup> s		

### 8.1.5 Electronics Blocks ET 200B-32DI (6ES7 131-0BL00-0XB0) and ET 200B-32DI 0.2ms (6ES7 131-0BL10-0XB0)

#### Characteristics

The ET 200B-32DI and ET 200B-32DI 0.2ms electronics blocks have the following features:

- 32 inputs, non-floating
- Input voltage: 24 V DC
- Input delay:
  - 6ES7 131-0BL00-0XB0 → 3 ms
  - 6ES7 131-0BL10-0XB0 → 0.2 ms
- Suitable for switches and 2/3-wire proximity switches (BEROs).

#### Dimension Drawing

Dimension drawing for ET 200B-32DI (6ES7 131-0BL00-0XB0) and ET 200B-32DI 0.2ms (6ES7 131-0BL10-0XB0):

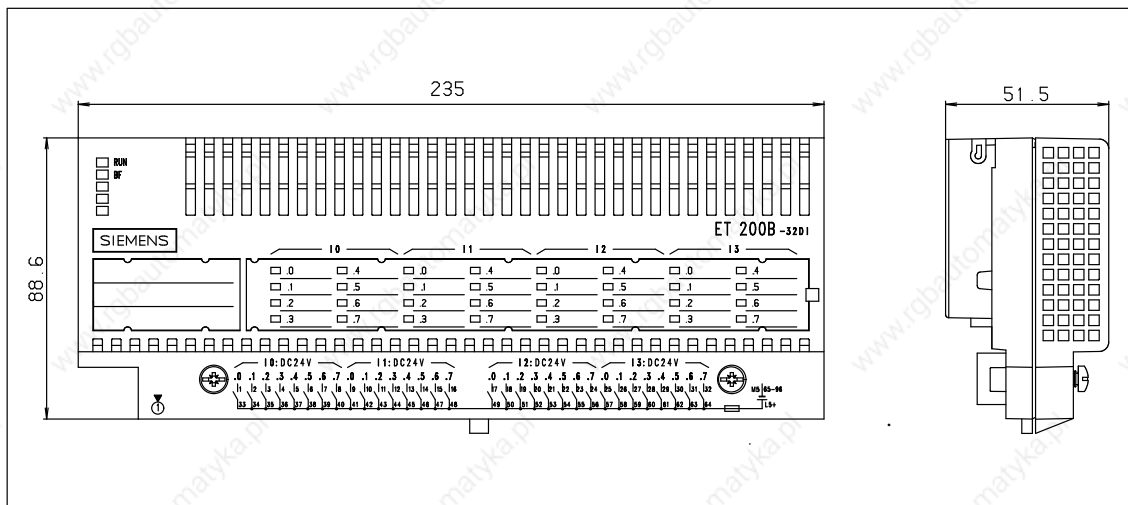

Figure 8-17 Dimension Drawing: ET 200B-32DI (6ES7 131-0BL00-0XB0) and ET 200B-32DI 0.2ms (6ES7 131-0BL10-0XB0)

## Electronics Blocks ET 200B-32DI (6ES7 131-0BL00-0XB0) and ET 200B-32DI 0.2ms (6ES7 131-0BL10-0XB0)

### Schematic Circuit Diagram

Simplified diagram of potential for the ET 200B-32DI or ET 200B-32DI 0.2 ms and TB2/DC or TB4/DC:

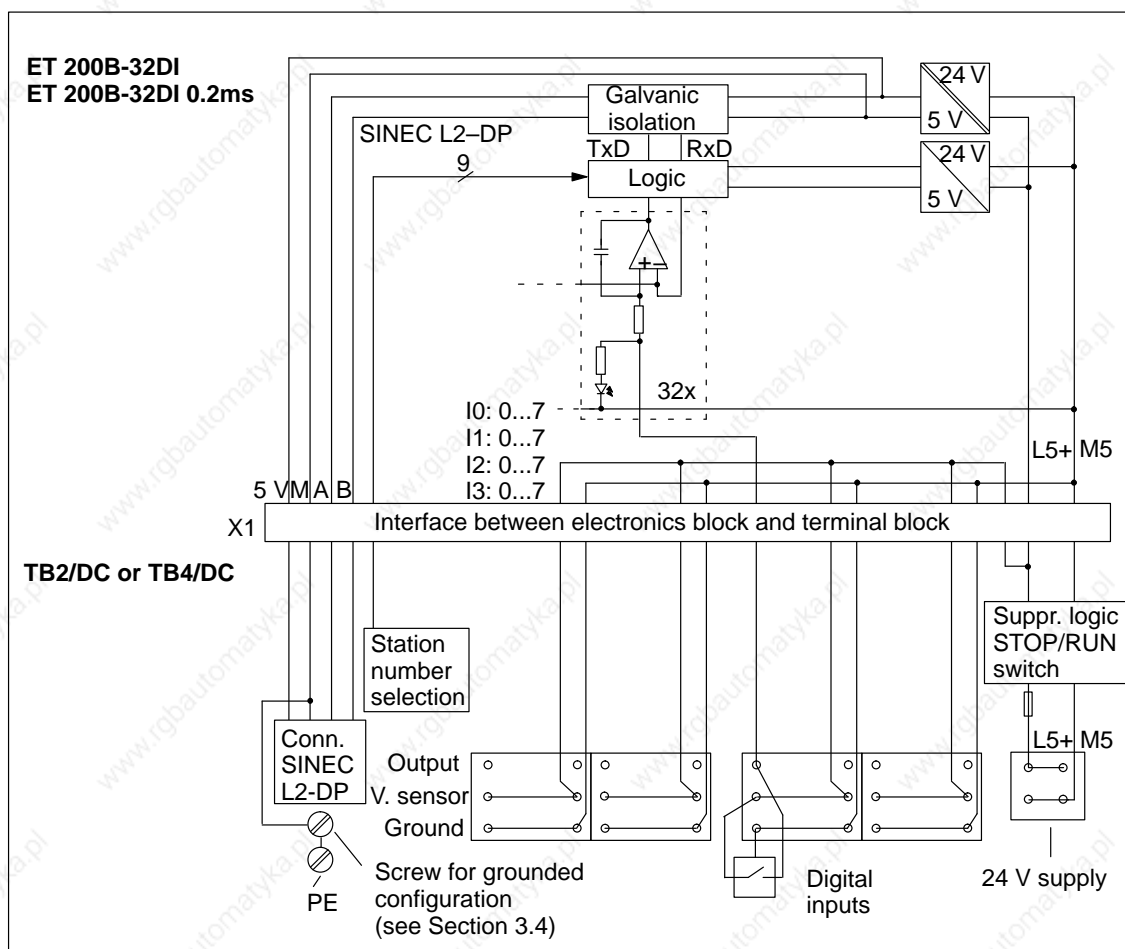

Figure 8-18 Schematic Circuit Diagram: ET 200B-32DI (6ES7 131-0BL00-0XB0) or ET 200B-32DI 0.2ms (6ES7 131-0BL10-0XB0) and TB2/DC or TB4/DC



## Electronics Blocks ET 200B-32DI (6ES7 131-0BL00-0XB0) and ET 200B-32DI 0.2ms (6ES7 131-0BL10-0XB0), continued

### Terminal Assignments

The ET 200B-32DI and ET 200B-32DI 0.2 ms can be plugged into the TB2/DC, TB2-4/DC or TB4/DC.

Table 8-4 contains the terminal assignments of the terminal blocks for the ET 200B-32DI and ET 200B-32DI 0.2 ms:

Table 8-4 Terminal Assignments of Terminal Blocks TB2/DC, TB2-4/DC and TB4/DC8-22 for ET 200B-32DI (6ES7 131-0BL00-0XB0) and ET 200B-32DI 0.2ms (6ES7 131-0BL10-0XB0)

Terminal	Assignment
1 to 8	I0: Inputs .0 to .7
9 to 16	I1: Inputs .0 to .7
17 to 24	I2: Inputs .0 to .7
25 to 32	I3: Inputs .0 to .7
33 to 64	24 V (sensor supply, internally jumpered)
65 to 96	Ground (sensor supply, internally jumpered)
34 terminals:  (TB2-4/DC only)	PE (internally jumpered, but not connected to PE screw) (TB2-4/DC only)
L5+	Power supply of the internal logic <b>and</b> 24 V sensor supply
L5+	Power supply of the internal logic <b>and</b> 24 V sensor supply
M5	Ground connection of the internal logic <b>and</b> sensor supply
M5	Ground connection of the internal logic <b>and</b> sensor supply

### Note

L5+ and terminals 33 to 64 are connected to each other, as are M5 and terminals 65 to 96.

Technical specifications		Inputs	
Baud rates for 6ES7 131-0BL10-0XB0 and 6ES7 131-0BL00-0BL0	9.6/19.2/93.75/187.5/500/1500/3000*/6000*/12000* kbps	Number of inputs	32
Bus protocol for 6ES7 131-0BL10-0XB0 and 6ES7 131-0BL00-0XB0	DP Standard	Galvanic isolation to internal electronic circuits	No
FREEZE capability for 6ES7 131-0BL10-0XB0 and 6ES7 131-0BL00-0XB0	Yes*	Input voltage	<ul style="list-style-type: none"> <li>• Rated value 24 V DC</li> <li>• For "0" signal – 30 V to 5 V</li> <li>• For "1" signal 13 V to 30 V</li> </ul>
Galvanic isolation to SINEC L2-DP	Yes	Input current for "1" signal	Typ. 4 mA for 24 V Min. 2 mA
Power losses	Typ. 4.8 W	Delay of inputs for 6ES7 131-0BL00-0XB0	3 ms
Weight (EB and TB)	Approx. 800 g (28 oz.)	Delay of inputs for 6ES7 131-0BL10-0XB0	0.2 ms
Dimensions (EB and TB): W x H x D)	235 x 130 x 60 mm (9.17 x 5.07 x 2.34 in.)	Connection of 2-wire BERO	Possible
		<ul style="list-style-type: none"> <li>• Quiescent current <math>\leq 1.5</math> mA</li> </ul>	
		Connection of mechanical switches	Possible
		Cable length of sensors	
		<ul style="list-style-type: none"> <li>• Unshielded Max. 100 m (328 ft.)</li> </ul>	
<b>Diagnostics functions</b>		* Only relevant when operating with the IM 308-C.	
Voltage monitoring	Green "RUN" LED		
Bus monitoring SINEC L2-DP	Red "BF" LED		
Status of inputs	Green LEDs		
<b>Supply voltage for inputs, sensor supply and internal logic</b>			
Supply logic (L5+)			
<ul style="list-style-type: none"> <li>• Rated value</li> <li>• Permissible range</li> <li>• Value for <math>t &lt; 0.5</math> s</li> </ul>	24 V DC 18.5 to 30.2 V 35 V		
Current consumption from L5+			
<ul style="list-style-type: none"> <li>• Logic</li> <li>• Sensors</li> </ul>	Typ. 70 mA Max. 1 A		
$I^2t$ (for inrush current)	$\leq 0.05$ A <sup>2</sup> s		

### 8.1.6 Electronics Block ET 200B-16DO (6ES7 132-0BH00-0XB0)

**Characteristics**

The ET 200B-16DO electronics block has the following features:

- 16 outputs, non-floating
- Load voltage: 24 V DC
- Output current: 0.5 A/2 A
- Suitable for solenoid valves and DC contactors.

**Dimension Drawing**

See Figure 8-14 for the precise dimensions.

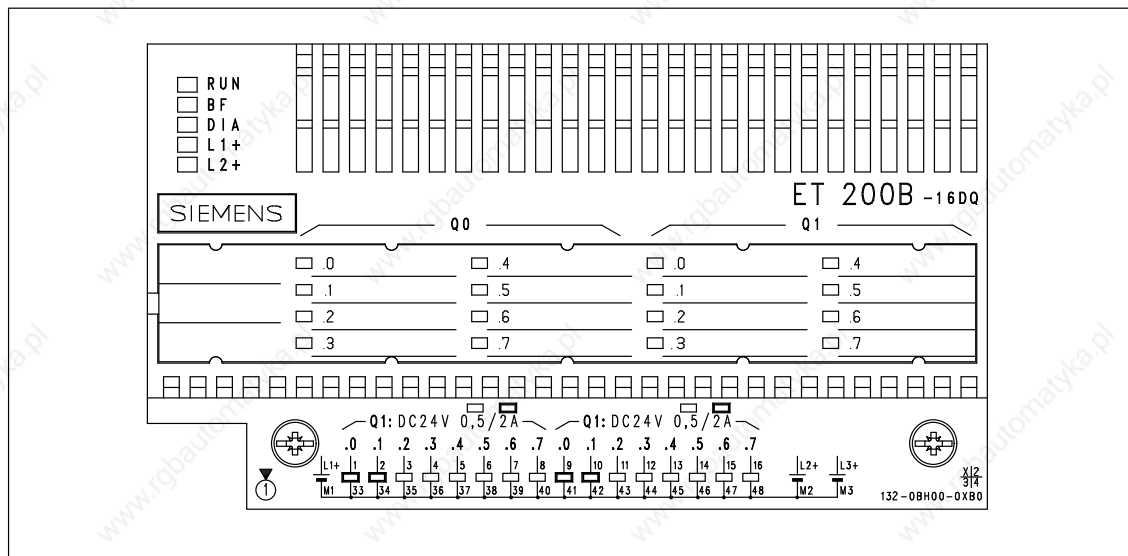

Figure 8-20 Front Elevation: ET 200B-16DO (6ES7 132-0BH00-0XB0)

**Schematic Circuit Diagram**

Simplified diagram of potential for the ET 200B-16DO and TB1/DC or TB3/DC:

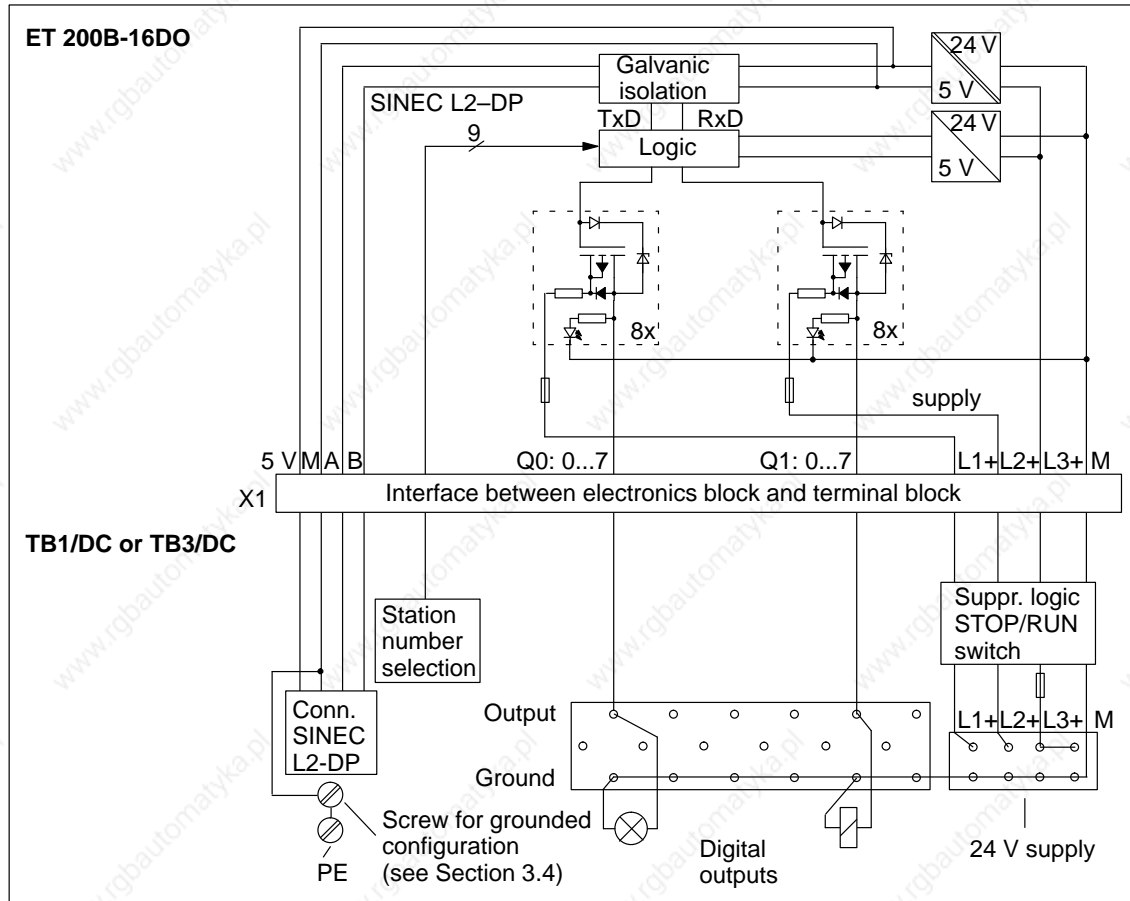

Figure 8-21 Schematic Circuit Diagram: ET 200B-16DO (6ES7 132-0BH0-0XB0) and TB1/DC or TB3/DC



## Electronics Block ET 200B-16DO (6ES7 132-0BH00-0XB0), continued

### Schematic Circuit Diagram

Simplified diagram of the potential for the ET 200B-16DO and TB1-4/DC:

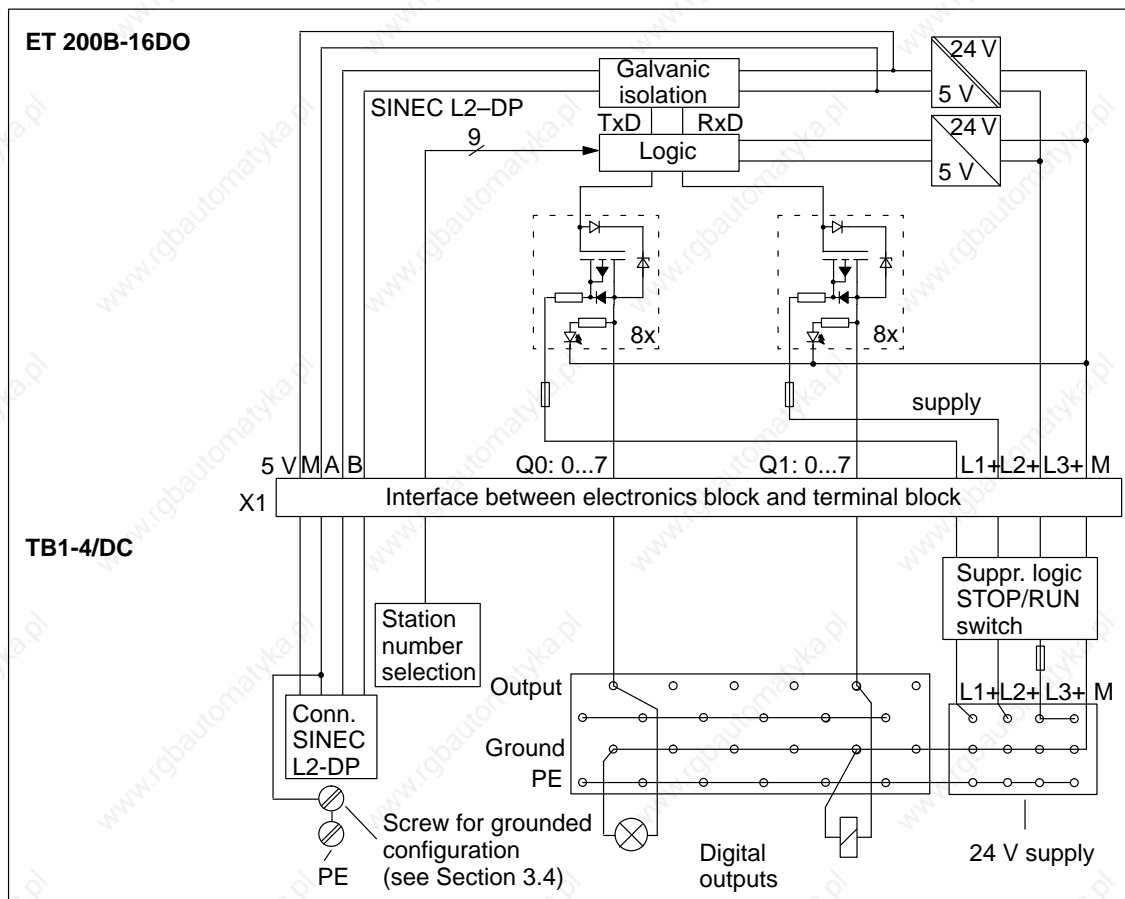

Figure 8-22 Schematic Circuit Diagram: ET 200B-16DO (6ES7 132-0BH00-0XB0) and TB1-4/DC

### Note

The connection terminals for PE on the 4-tier terminal block are not connected to the PE terminal of the TB1-4/DC terminal block.

## Terminal Assignments

The ET 200B-16DO can be plugged into the TB1/DC, TB1-4/DC or TB3/DC.

Table 8-5 contains the terminal assignments of the terminal blocks for the ET 200B-16DO:

Table 8-5 Terminal Assignments of Terminal Blocks TB1/DC, TB1-4/DC and TB3/DC for ET 200B-16DO (6ES7 132-0BH00-0XB0)

Terminal	Assignment
1 to 8	Q0: Outputs .0 to .7
9 to 16	Q1: Outputs .0 to .7
17 to 32	Unassigned
33 to 48	Ground (internally jumpered)
20 terminals.  (TB1-4/DC only)	PE (internally jumpered, but not connectd to PE screw) (TB1-4/DC only)
L1+	Power supply L1+ for channel group Q0: .0 to .7
L2+	Power supply L2+ for channel group Q1: .0 to .7
L3+	Power supply for the internal logic
L3+	Power supply for the internal logic
M1	Ground connection M1 for channel group Q0: .0 to .7
M2	Ground connection M2 for channel group Q1: .0 to .7
M3	Ground connection of internal logic
M3	Ground connection of internal logic

### Note

L1+, L2+ and L3+ are **not** connected to each other.

M1, M2, M3 and terminals 33 to 48 are connected to each other internally.

## Electronics Block ET200B-16DO (6ES7 132-0BH00-0XB0), continued

Technical specifications		Outputs	
Baud rates	9.6/19.2/93.75/187.5/500/ 1500/3000*/6000*/ 12000* kbps	Number of outputs	16
Bus protocol	DP standard	Galvanic isolation	No
SYNC capability	Yes*	• In groups of	8
Galvanic isolation to SINEC L2-DP bus	Yes	Output voltage	
Power losses	Max. 5 W	• For "0" signal	Max. 2 V (idle)
Weight (EB and TB)	Approx. 600 g (21 oz.)	• For "1" signal	Min. (supply voltage – 3 V)
Dimensions (EB and TB: W x H x D)	160 x 130 x 60 mm (6.24 x 5.07 x 2.34 in.)	Output voltage	
		• For "0" signal	Max. 1 mA
		• For "1" signal	Max. 2 A (2 outputs per group; .0 and .1) Max. 0.5 A (6 outputs per group; .2 to .7)
Diagnostics functions		Delay of outputs	Max. 1 ms
Voltage monitoring	Green "RUN" LED	• At max. lamp load	Max. 80 ms
Bus monitoring SINEC L2-DP	Red "BF" LED	Switching frequency	
Group diagnostics for short-circuit, load voltage failure	Red "DIA" LED	• Resistive load	Max. 100 Hz
Load voltage monitoring, by group	Green "L1+", "L2+" LEDs	• Inductive load	Max. 0.5 Hz
Status of outputs	Green LEDs	• Lamp load	Max. 8 Hz
Supply voltage for outputs, load voltage supply and internal logic		Load current per group	
Supply voltages (L1+,L2+,L3+)		• Total current	Max. 4 A
• Rated value	24 V DC	• In case of short-circuit	Max. 6.5 A
• Permissible range	18.5 to 30.2 V	Lamp load	
• Value for t < 0.5 s	35 V	• At I = 0.5 A	Max. 5 W
Current consumption from L3+		• At I = 2 A	Max. 10 W
• Logic	80 mA	Setting a digital input	Possible
I <sup>2</sup> t (for inrush current)	≤ 0.05 A <sup>2</sup> s	Limitation of voltage induced on current interruption	Typ. (L5+) –55 V
Short-circuit protection in case of polarity reversal (L1+ and L2+) of load voltage	No		

\* Only relevant when operating with the IM 308-C.

### 8.1.7 Electronics Block ET 200B-16DO/2A (6ES7 132-0BH10-0XB0)

**Characteristics**

The ET 200B-16DO/2A electronics block has the following features:

- 16 outputs, floating in groups of 4
- Load voltage: 24 V DC
- Output current: 2 A

**Dimension Drawing**

See Figure 8-17 for the precise dimensions.

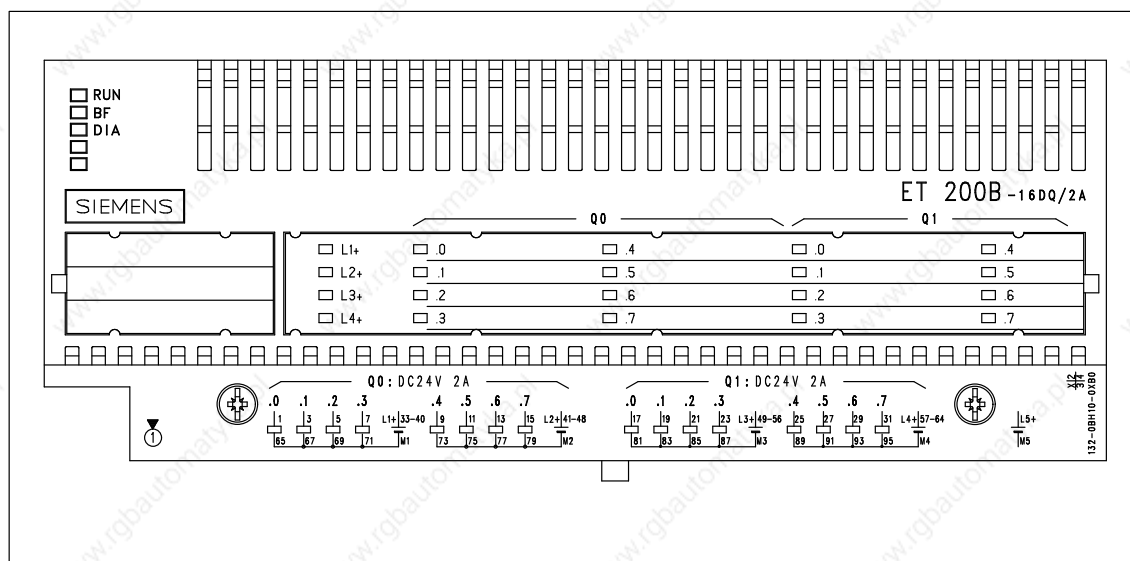

Figure 8-23 Front Elevation: ET 200B-16DO/2A (6ES7 132-0BH10-0XB0)

## Electronics Block ET 200B-16DO/2A (6ES7 132-0BH10-0XB0), continued

### Schematic Circuit Diagram

Simplified diagram of the potential for the ET 200B-16DO/2A and TB2/DC or TB4/DC:

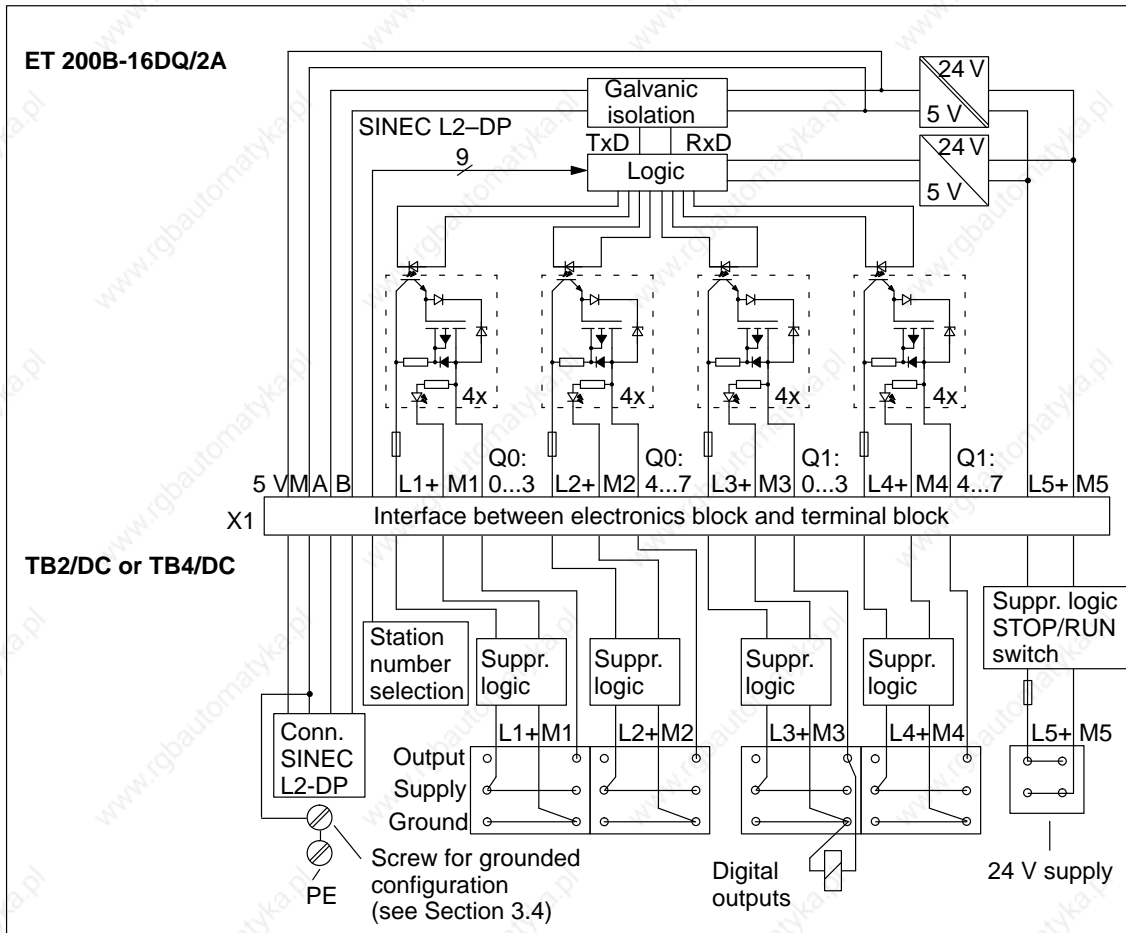

Figure 8-24 Schematic Circuit Diagram: ET 200B-16DO/2A (6ES7 132-0BH10-0XB0) and TB2/DC or TB4/DC

**Schematic Circuit Diagram**

Simplified diagram of the potential for the ET 200B-16DO/2A and TB2-4/DC:

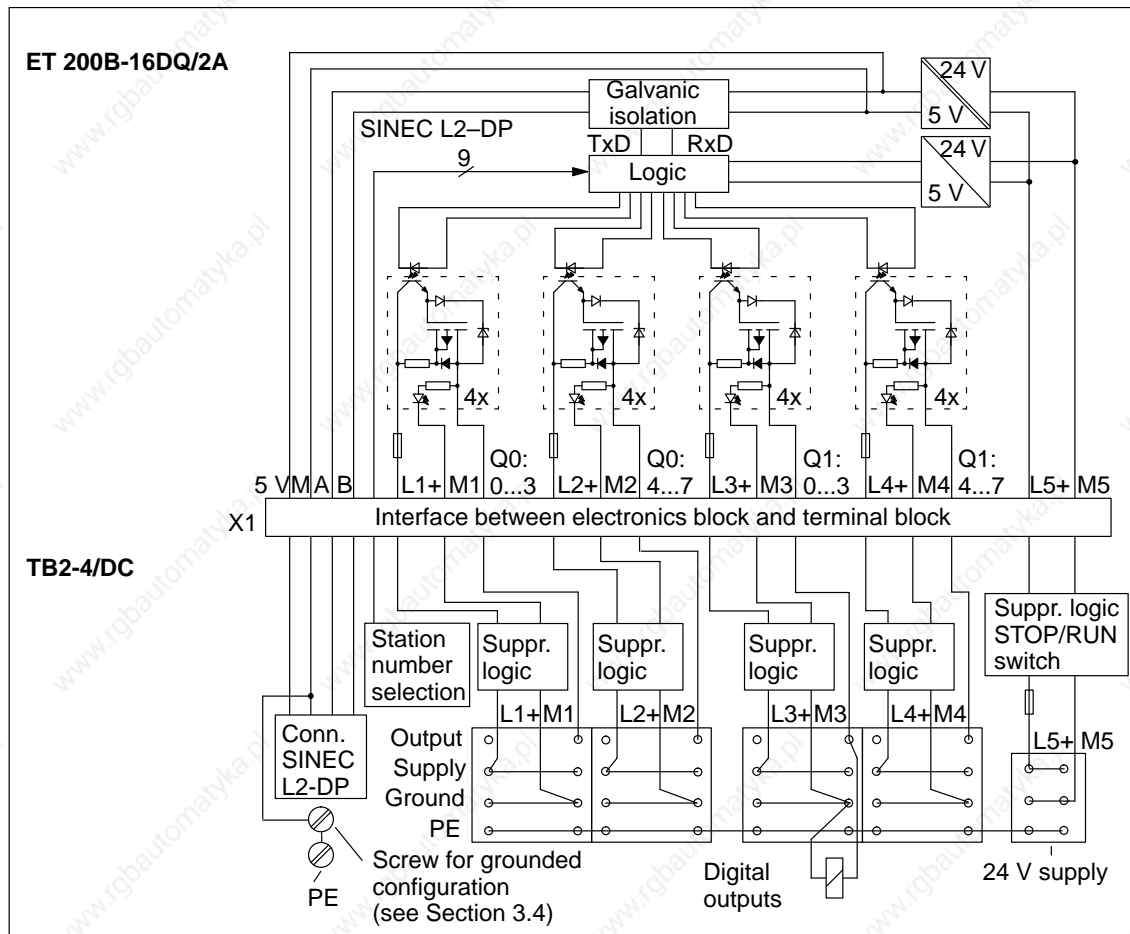

Figure 8-25 Schematic Circuit Diagram: ET 200B-16DO/2A (6ES7 132-0BH10-0XB0) and TB2-4/DC

**Note**

The connection terminals for PE on the 4-tier terminal block are not connected to the PE terminal of the TB2-4/DC terminal block.

## Electronics Block ET 200B-16DO/2A (6ES7 132-0BH10-0XB0), continued

### Terminal Assignments

The ET 200B-16DO/2A can be plugged into the TB2/DC, TB2-4/DC or TB4/DC.

Table 8-6 contains the terminal assignments of the terminal blocks for the ET 200B-16DO/2A:

Table 8-6 Terminal Assignments of Terminal Blocks TB2/DC, TB2-4/DC and TB4/DC for ET 200B-16DO/2A (6ES7 132-0BH10-0XB0)

Terminal <sup>1</sup>	Assignment
1, 3, 5 to 15	Q0: Outputs .0 to .7
17, 19, 21 to 31	Q1: Outputs .0 to .7
33 to 40	Power supply L1+ for channel group Q0: .0 to .3 (internally jumpered)
41 to 48	Power supply L2+ for channel group Q0: .4 to .7 (internally jumpered)
49 to 56	Power supply L3+ for channel group Q1: .0 to .3 (internally jumpered)
57 to 64	Power supply L4+ for channel group Q1: .4 to .7 (internally jumpered)
65 to 72	Ground M1 for channel group Q0: .0 to .3 (internally jumpered)
73 to 80	Ground M2 for channel group Q0: .4 to .7 (internally jumpered)
81 to 88	Ground M3 for channel group Q1: .0 to .3 (internally jumpered)
89 to 96	Ground M4 for channel group Q1: .4 to .7 (internally jumpered)
34 terminals  (TB2-4/DC only)	PE (internally jumpered, but not connected to PE screw) (TB2-4/DC only)
L5+	Power supply of the internal logic
L5+	Power supply of the internal logic
M5	Ground connection of the internal logic
M5	Ground connection of the internal logic

<sup>1</sup> Terminals 2, 4, 6, 8, 10, 12, 14, 16, 18, 20, 22, 24, 26, 28, 30, 32 are unassigned.

### Note

If all actuators have 2-wire connections to TB2/DC or TB4/DC, terminate for each group the ground connection of one actuator and the incoming reference potential line via a terminal pin in accordance with DIN 46231.

L1+ to L5+ and M1 to M5 are not connected to each other internally.

Technical specifications		Outputs	
Baud rates	9.6/19.2/93.75/187.5/500/ 1500/3000*/6000*/ 12000* kbps	Number of outputs	16
Bus protocol	DP standard	Galvanic isolation	Yes
SYNC capability	Yes*	• In groups of	4
Galvanic isolation to SINEC L2-DP bus	Yes	Output voltage	
Power losses	Max. 7 W	• For "0" signal	Max. 2 V (idle)
Weight (EB and TB)	Approx. 900 g (31.5 oz.)	• For "1" signal	Min. (supply voltage – 3 V)
Dimensions (EB and TB: W x H x D)	235 x 130 x 60 mm (9.17 x 5.07 x 2.34 in.)	Output	
<b>Diagnostics functions</b>		• For "0" signal	Max. 1 mA
Voltage monitoring	Green "RUN" LED	• For "1" signal	Max. 2 A
Bus monitoring SINEC L2-DP	Red "BF" LED	Delay of outputs	Max. 1 ms
Group diagnostics for short-circuit, load voltage failure	Red "DIA" LED	• At max. lamp load	Max. 80 ms
Load voltage monitoring, by channel group (QO, Q1)	Green LEDs "L1+/"L2+" (QO: .0 to 7) "L3+/"L4+" (Q1: .0 to 7)	Switching frequency	
Status of outputs	Green LEDs	• Resistive load	Max. 100 Hz
<b>Supply voltage for outputs, load voltage supply and internal logic</b>		• Inductive load	Max. 0.5 Hz
Supply voltage (L1+,L2+,L3+,L4+,L5+)		• Lamp load	Max. 8 Hz
• Rated value	24 V DC	Load current per group	
• Permissible range	18.5 to 30.2 V	• Total current	Max. 4 A
• Value at t < 0.5 s	35 V	• In case of short-circuit	Max. 6.5 A
Current consumption from L5+		Lamp load	Max. 10 W
• Logic	100 mA	Setting a digital input	Possible
I <sup>2</sup> t (for inrush current)	≤ 0.05 A <sup>2</sup> s	Cable length	Max. 100 m (328 ft.)
Short-circuit protection in case of polarity reversal (L1+,L2+,L3+,L4+) of load voltage	No		

\* Only relevant when operating with the IM 308-C.



### 8.1.8 Electronics Block ET 200B-32DO (6ES7 132-0BL00-0XB0)

**Characteristics**

The ET 200B-32DO electronics block has the following features:

- 32 outputs, floating in groups of 8
- Load voltage: 24 V DC
- Output voltage: 0.5 A
- Suitable for solenoid valves and DC contactors

**Dimension Drawing**

See Figure 8-17 for the precise dimensions.

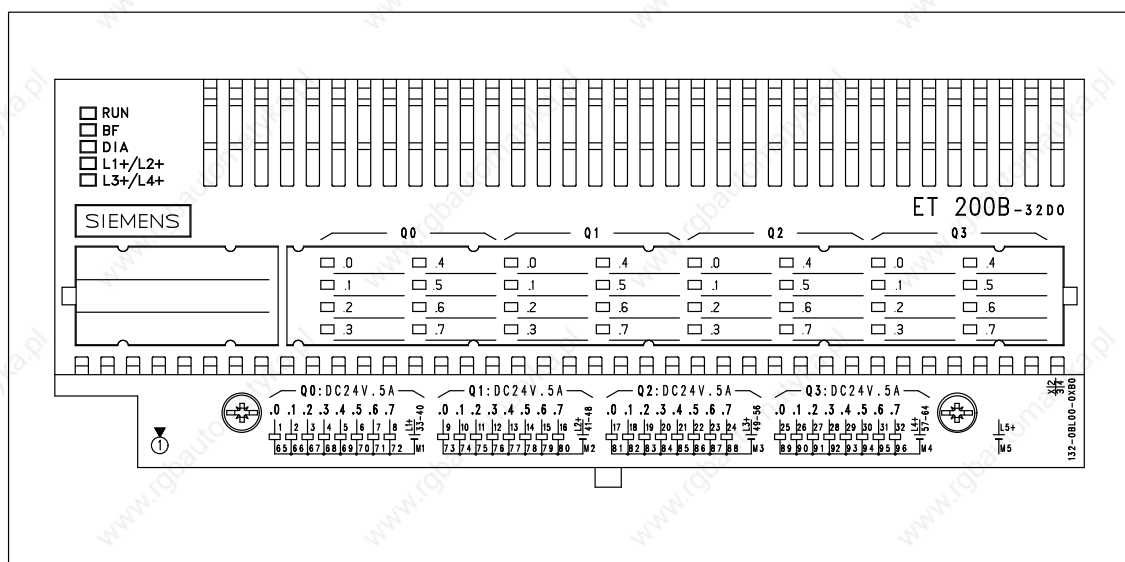

Figure 8-26 Front Elevation: ET 200B-32DO (6ES7 132-0BL00-0XB0)

**Schematic Circuit Diagram**

Simplified diagram of potential for the ET 200B-32DO and TB2/DC or TB4/DC:

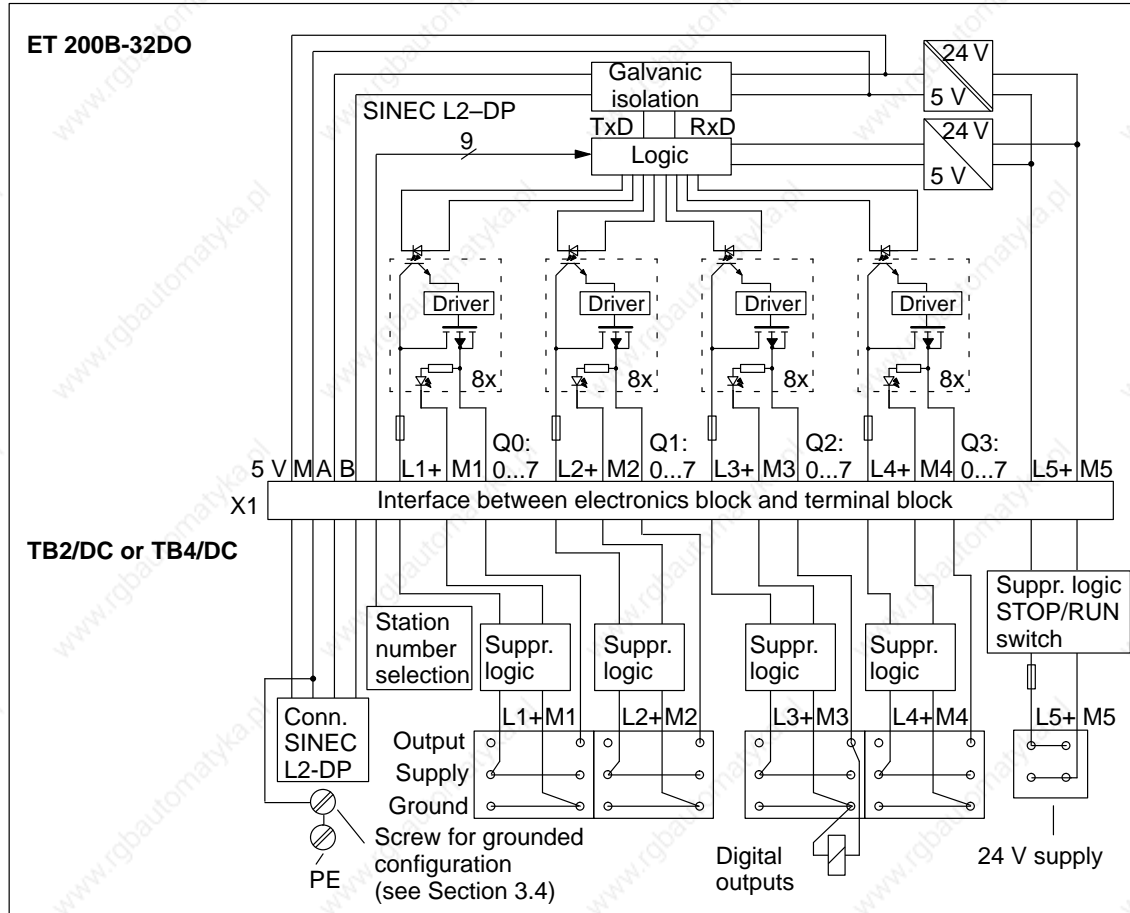

Figure 8-27 Schematic Circuit Diagram: ET 200-B-32DO (6ES7 132-0BL00-0BX0) and TB2/DC or TBA/DC

## Electronics Block ET 200B-32DO (6ES7 132-0BL00-0XB0), continued

### Schematic Circuit Diagram

Simplified diagram of the potential for the ET 200B-32DO and TB2-4/DC:

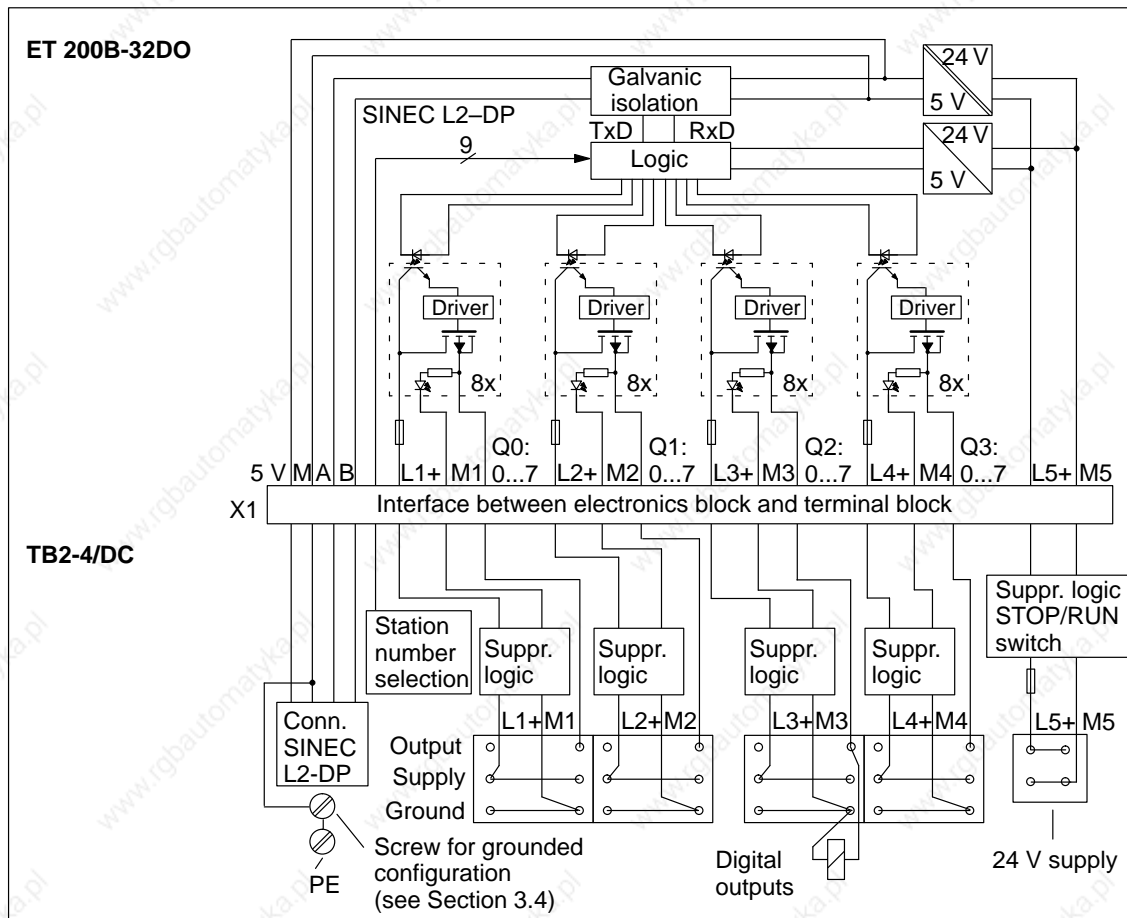

Figure 8-28 Schematic Circuit Diagram: ET 200B-32DO (6ES7 132-0BL00-0XB0) and TB2-4/DC

### Note

The connection terminals for PE on the 4-tier terminal block are not connected to the PE terminal of the TB2-4/DC terminal block.

## Terminal Assignments

The ET 200B-32DO can be plugged into the TB2/DC, TB2-4/DC or TB4/DC.

Table 8-7 contains the terminal assignments of the terminal blocks for the ET 200B-32DO:

Table 8-7 Terminal Assignments of Terminal Blocks TB2/DC, TB2-4/DC and TB4/DC for ET 200B-32DO (6ES7 132-0BL00-0XB0)

Terminal	Assignment
1 to 8	Q0: Outputs .0 to .7
9 to 16	Q1: Outputs .0 to .7
17 to 24	Q2: Outputs .0 to .7
25 to 32	Q3: Outputs .0 to .7
33 to 40	Power supply L1+ for channel group Q0: .0 to .7 (internally jumpered)
41 to 48	Power supply L2+ for channel group Q1: .0 to .7 (internally jumpered)
49 to 56	Power supply L3+ for channel group Q2: .0 to .7 (internally jumpered)
57 to 64	Power supply L4+ for channel group Q3: .0 to .7 (internally jumpered)
65 to 72	Ground M1 for channel group Q0: .0 to .7 (internally jumpered)
73 to 80	Ground M2 for channel group Q1: .0 to .7 (internally jumpered)
81 to 88	Ground M3 for channel group Q2: .0 to .7 (internally jumpered)
89 to 96	Ground M4 for channel group Q3: .0 to .7 (internally jumpered)
34 terminals  (TB2-4/DC only)	PE (internally jumpered, but not connected to PE screw) (TB2-4/DC only)
L5+	Power supply of the internal logic
L5+	Power supply of the internal logic
M5	Ground connection of the internal logic
M5	Ground connection of the internal logic

### Note

If all actuators have 2-wire connections to TB2/DC or TB4/DC, terminate for each group the ground connection of one actuator and the incoming reference potential line via a terminal pin in accordance with DIN 46231.

L1+ to L5+ and M1 to M5 are not connected to each other internally.

## Electronics Block ET 200B-32DO (6ES7 132-0BL00-0XB0), continued

Technical specifications		Outputs	
Baud rates	9.6/19.2/93.75/187.5/500/ 1500/3000*/6000*/ 12000* kbps	Number of outputs	32
Bus protocol	DP Standard	Galvanic isolation	Yes
SYNC capability	Yes*	• In groups of	8
Galvanic isolation to SINEC L2-DP bus	Yes	Output voltage	
Power losses	Max. 7.9 W	• For "0" signal	Max. 2 V (idle)
Weight (EB and TB)	Approx. 800 g (28 oz.)	• For "1" signal	Min. (supply voltage – 3 V)
Dimensions (EB and TB: W x H x D)	235 x 130 x 60 mm (9.17 x 5.07 x 2.34 in.)	Output current	
<b>Diagnostics functions</b>		• For "0" signal	Max. 1 mA
Voltage monitoring	Green "RUN" LED	• For "1" signal	Max. 0.5 A
Bus monitoring SINEC L2-DP	Red "BF" LED	Delay of outputs	
Group diagnostics for short-circuit, load voltage failure	Red "DIA" LED	• From "0" to "1"	Approx. 20 µs
Load voltage monitoring	Green "L1+/L2+", "L3+/L4+" LEDs	• From "1" to "0"	Max. 0.5 ms
Status of outputs	Green LEDs	Switching frequency	
<b>Supply voltage for outputs, load voltage supply and internal logic</b>		• Resistive load	Max. 1000 Hz
Supply voltage (L1+,L2+,L3+,L4+,L5+)		• Inductive load	Max. 0.5 Hz
• Rated value	24 V DC	• Lamp load	Max. 8 Hz
• Permissible range	18.5 to 30.2 V	Short-circuit protection	Yes
• Value for $t < 0.5$ s	35 V	Load current per group	
$I^2t$ (for inrush current)	$\leq 0.05$ A <sup>2</sup> s	• Total current	Max. 2 A
Current consumption from L5+		Lamp load	Max. 5 W
• Logic	Typ. 75 mA	Setting a digital input	Possible
		Limitation of voltage induced on current interruption	Typ. (L5+) – 55 V
		Cable length	Max. 100 m (328 ft.)

\* Only relevant when operating with the IM 308-C.

## 8.1.9 Electronics Block ET 200B-8RO (6ES7 132-0GF00-0XB0)

### Characteristics

The ET 200B-8RO electronics block has the following features:

- 8 relay outputs, floating in groups of 1
- Switching voltage: 24 to 60 V DC

### Dimension Drawing

See Figure 8-14 for the precise dimensions.

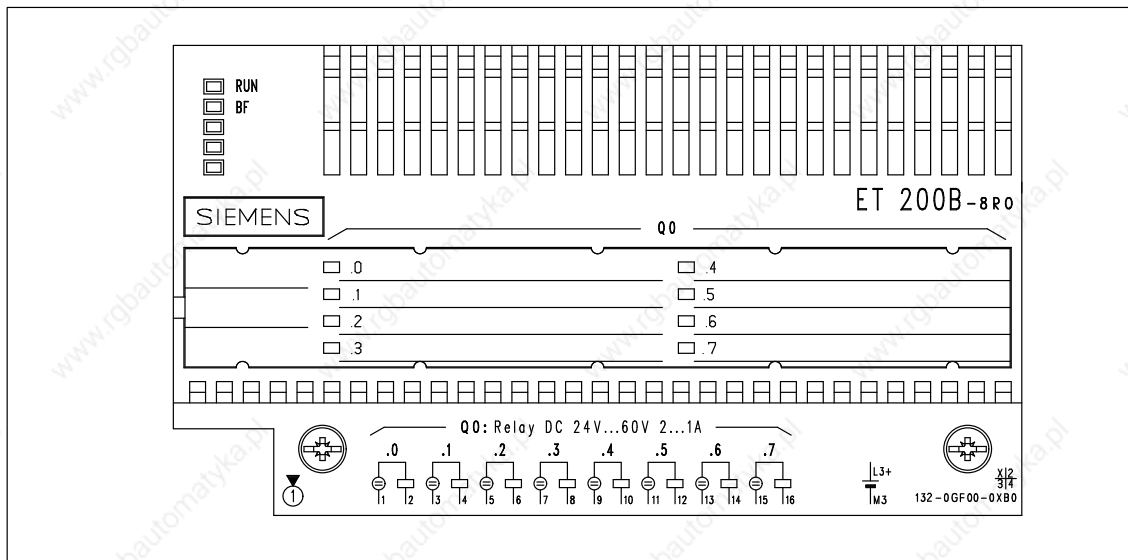

Figure 8-29 Front Elevation: ET 200B-8RO (6ES7 132-0GF00-0XB0)

## Electronics Block ET 200B-8RO (6ES7 132-0GF00-0XB0), continued

### Schematic Circuit Diagram

Simplified diagram of the potential for the ET 200B-8RO and TB1/DC or TB3/DC:

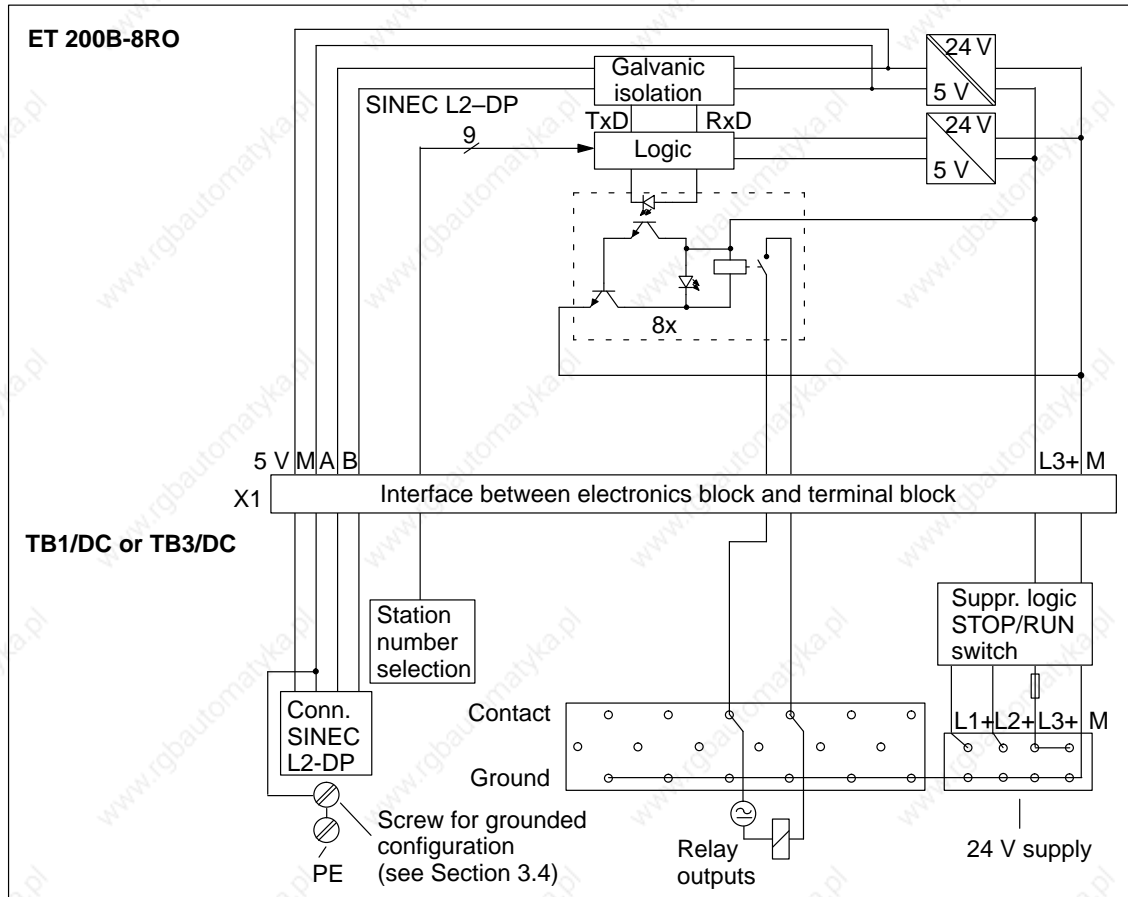

Figure 8-30 Schematic Circuit Diagram: ET 200B-8RO (6ES7 132-0GF00-0XB0) and TB1/DC or TB3/DC

**Schematic Circuit Diagram**

Simplified diagram of the potential for the ET 200B-8RO and TB1-4/DC:

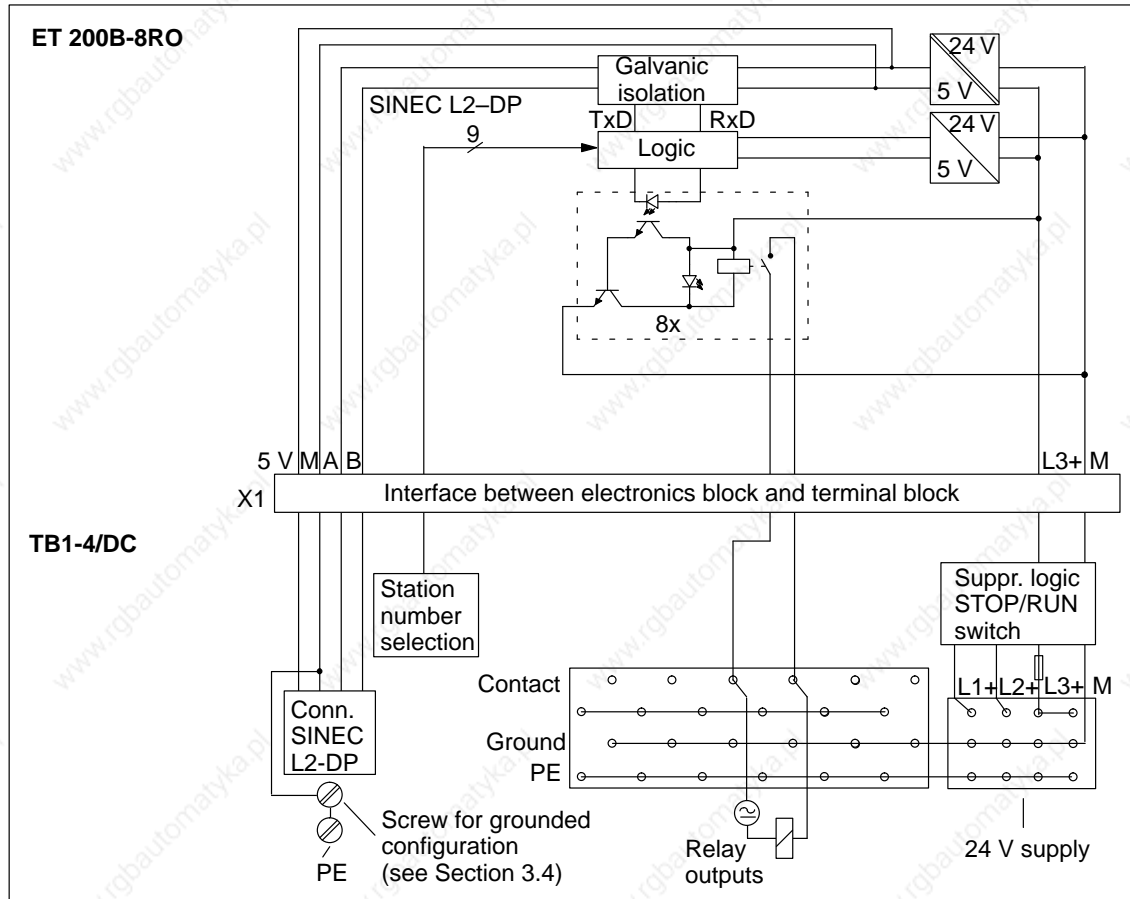

Figure 8-31 Schematic Circuit Diagram: ET 200B-8RO (6ES7 132-0GF00-0XB0) and TB1-4/DC

**Note**

The connection terminals for PE on the 4-tier terminal block are not connected to the PE terminal of the TB1-4/DC terminal block.



## Electronics Block ET 200B-8RO (6ES7 132-0GF00-0XB0), continued

### Terminal Assignments

The ET 200B-8RO can be plugged into the TB1/DC, TB1-4/DC or TB3/DC.

Table 8-8 contains the terminal assignments of the terminal blocks for the ET 200B-8RO:

Table 8-8 Terminal Assignments of Terminal Blocks TB1/DC, TB1-4/DC and TB3/DC for ET 200B-8RO (6ES7 132-0GF00-0XB0)

Terminal	Assignment
1	Q0: Output 0/0
2	Q0: Output 0/1
3	Q0: Output 1/0
4	Q0: Output 1/1
5	Q0: Output 2/0
6	Q0: Output 2/1
7	Q0: Output 3/0
8	Q0: Output 3/1
9	Q0: Output 4/0
10	Q0: Output 4/1
11	Q0: Output 5/0
12	Q0: Output 5/1
13	Q0: Output 6/0
14	Q0: Output 6/1
15	Q0: Output 7/0
16	Q0: Output 7/1
17 to 32	Unassigned
33 to 48	Ground (internally jumpered)
20 terminals:  (TB1-4/DC only)	PE (internally jumpered, but not connected to PE screw) (TB1-4/DC only)
L1+	Unassigned
L2+	Unassigned
L3+	Power supply of the internal logic
L3+	Power supply of the internal logic
M1	Unassigned
M2	Unassigned
M3	Ground connection of the internal logic
M3	Ground connection of the internal logic

**Note**

M1, M2, M3 and terminals 33 to 48 are connected to each other.

Technical specifications		Relay outputs	
Baud rates	9.6/19.2/93.75/187.5/500/ 1500/3000*/6000*/ 12000* kbps	Number of outputs	8
Bus protocol	DP standard	Galvanic isolation	Yes
SYNC capability	Yes*	• In groups of	1
Galvanic isolation to the SINEC L2-DP bus	Yes	Short-circuit protection	No
Power losses	Typ. 2 W	Continuous current $I_{th}$	Max. 5 A
Weight (EB and TB)	Approx. 650 g (22.75 oz.)	Relay type	Dold OW 5699
Dimensions (EB and TB: W x H x D)	160 x 130 x 60 mm (6.24 x 5.07 x 2.34 in.)	Cycling capacity of contacts	
<b>Diagnostics functions</b>		• Resistive load	Max. 2 A at 24 V DC Max. 1.5 A at 48 V DC Max. 1 A at 60 V DC
Voltage monitoring	Green "RUN" LED	• Inductive load	Max. 0.5 A at 30 V DC
Bus monitoring SINEC L2-DP	Red "BF" LED	Mechanical service life	> 10 <sup>8</sup> switching operations
Status of outputs	Green LEDs	Switching rate	Max. 20/s
<b>Supply voltage for relay outputs and internal logic</b>		Cable length	
Supply voltage (L3+)		• Unshielded	Max. 100 m (328 ft.)
• Rated value	24 V DC	Setting of a digital input	Possible
• Permissible range	18.5 to 30.2 V		
• Value for $t < 0.5$ s	35 V		
Current consumption from L3+			
• Logic	Typ. 130 mA		
$I^2t$ (for inrush current)	$\leq 0.05$ A <sup>2</sup> s		

\* Only relevant when operating with the IM 308-C.

### 8.1.10 Electronics Block ET 200B-8DI/8DO (6ES7 133-0BH00-0XB0)

**Characteristics**

The ET 200B-8DI/8DO electronics block has the following features:

- 8 inputs, non-floating
- 8 outputs, non-floating
- Input voltage: 24 V DC
- Input delay: 3 ms
- Load voltage: 24 V DC

**Dimension Drawing**

See Figure 8-14 for the precise dimensions.

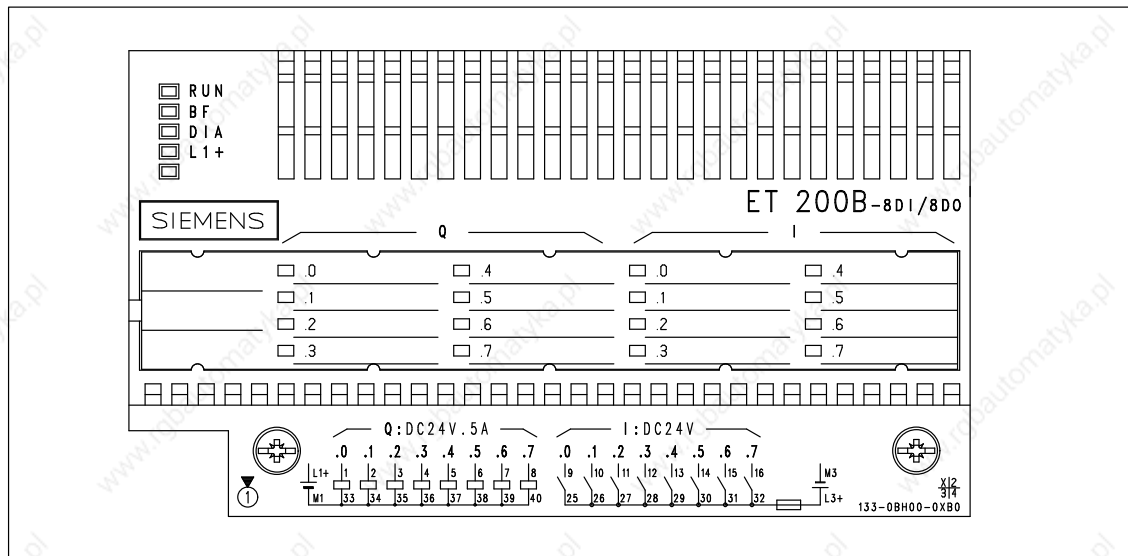

Figure 8-32 Front Elevation: ET 200B-8DI/8DO (6ES7 133-0BH00-0XB0)

**Schematic Circuit Diagram**

Simplified diagram of potential for the ET 200B-8DI/8DO and TB1/DC or TB3/DC:

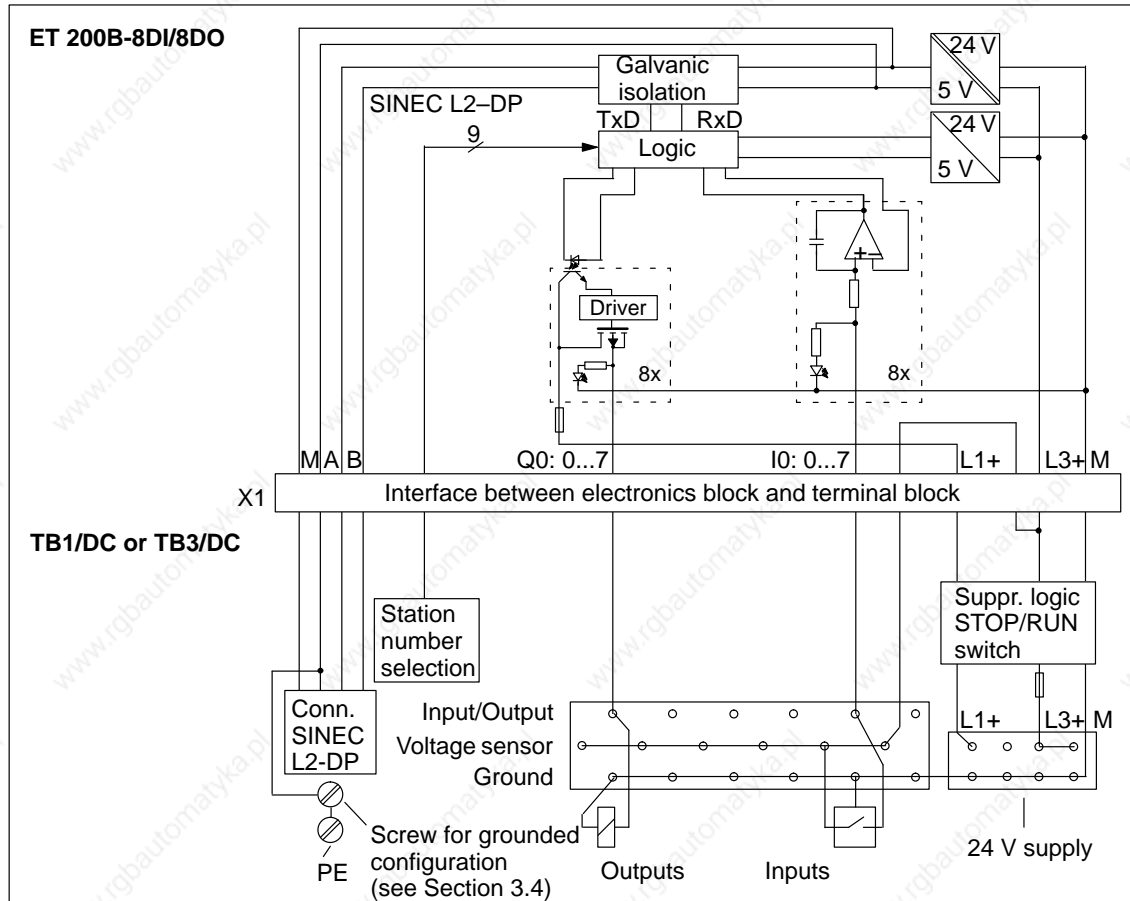

Figure 8-33 Schematic Circuit Diagram: ET 200B-8DI/8DO (6ES7 133-0BH00-0XB0) and TB1/DC or TB3/DC

## Electronics Blocks ET 200B-8DI/8DO (6ES7 133-0BH00-0XB0), continued

### Schematic Circuit Diagram

Simplified diagram of the potential for the ET 200B-8DI/8DO and TB1-4/DC:

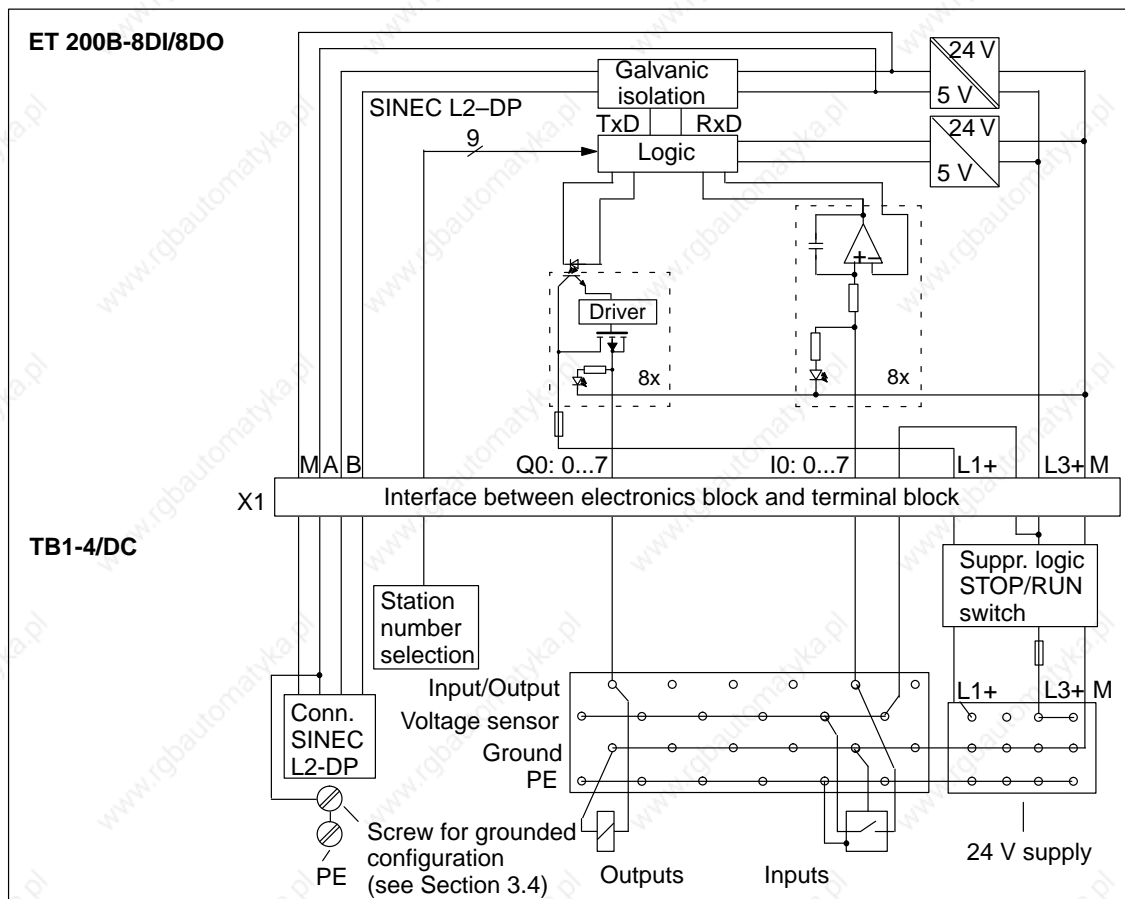

Figure 8-34 Schematic Circuit Diagram: ET 200B-8DI/8DO (6ES7 133-0BH00-0XB0) and TB1-4/DC

### Note

The connection terminals for PE on the 4-tier terminal block are not connected to the PE terminal of the TB1-4/DC terminal block.

## Terminal Assignments

The ET 200B-8DI/8DO can be plugged into the TB1/DC, TB1-4/DC or TB3/DC.

Table 8-9 contains the terminal assignments of the terminal blocks for the ET 200B-8DI/8DO:

Table 8-9 Terminal Assignments of Terminal Blocks TB1/DC, TB1-4/DC and TB3/DC for ET 200B-8DI/8DO (6ES7 133-0BH00-0XB0)

Terminal	Assignment
1 to 8	Q0: Output .0 to .7
9 to 16	I0: Input .0 to .7
17 to 24	24 V (sensor supply) (internally jumpered)
25 to 32	24 V (sensor supply) (internally jumpered)
33 to 40	Ground (outputs) (internally jumpered)
41 to 48	Ground (sensor supply) (internally jumpered)
20 terminals:  (TB1-4/DC only)	PE (internally jumpered, but not connected to PE screw) (TB1-4/DC only)
L1+	Power supply L1+ for channel group Q0: .0 to .7
L2+	Unassigned
L3+	Power supply of the internal logic <b>and</b> 24 V sensor supply
L3+	Power supply of the internal logic <b>and</b> 24 V sensor supply
M1	Ground connection M1 for channel group Q0: .0 to .7
M2	Unassigned
M3	Ground connection of the internal logic <b>and</b> sensor supply
M3	Ground connection of the internal logic <b>and</b> sensor supply

### Note

L1+ and L3+ are **not** connected to each other internally.

L3+ and terminals 25 to 32 are connected to each other, as are M1, M2, M3 and terminals 33 to 48.

## Electronics Block ET 200B-8DI/8DO (6ES7 133-0BH00-0XB0), continued

Technical specifications		Inputs, continued	
Baud rates	9.6/19.2/93.75/187.5/500/ 1500/3000*/6000*/ 12000* kbps	Input current for "1" signal	Typ. 4 mA at 24 V Min. 2 mA
Bus protocol	DP Standard	Delay of inputs for 6ES7 133-0BN00-0XB0	3 ms
FREEZE and SYNC capability	Yes*	Delay of inputs for 6ES7 133-0BN10-0XB0	0.2 ms
Galvanic isolation to SINEC L2-DP bus	Yes	Connection of 2-wire BERO	Possible
Power losses	Max. 3.8 W	• Quiescent current	≤ 1.5 mA
Weight (EB and TB)	Approx. 650 g (22.75 oz.)	Connection of mechanical switches	Possible
Dimensions (EB and TB: W x H x D)	160 x 130 x 60 mm (6.24 x 5.07 x 2.34 in.)	Cable length of sensors	
<b>Diagnostics functions</b>		• Unshielded	Max. 100 m (328 ft.)
Voltage monitoring	Green "RUN" LED	<b>Outputs</b>	
Bus monitoring SINEC L2-DP	Red "BF" LED	Number of outputs	8
Group diagnostics for short-circuit, load voltage failure	Red "DIA" LED	Galvanic isolation	No
Load voltage monitoring	Green "L1+" LED	• In groups of	8
Status of inputs and outputs	Green LEDs	Output voltage	
<b>Supply voltage for sensor supply, load voltage supply and internal logic</b>		• For "0" signal	Max. 2 V (idle)
Supply voltage (L1+,L3+)		• For "1" signal	Min. (supply voltage – 3 V)
• Rated value	24 V DC	Output current	
• Permissible range	18.5 to 30.2 V	• For "0" signal	Max. 1 mA
• Value for $t < 0.5$ s	35 V	• For "1" signal	Max. 0.5 A
Current consumption from L3+		Delay of outputs	
• Logic	Typ. 70 mA	• From "0" to "1"	Approx. 20 $\mu$ s
• Sensors	Max. 500 mA	• From "1" to "0"	Max. 0.5 ms
$I^2t$ (for inrush current)	≤ 0.05 A <sup>2</sup> s	Switching frequency	
<b>Inputs</b>		• Resistive load	Max. 100 Hz
Number of inputs	8	• Inductive load	Max. 0.5 Hz
Galvanic isolation to internal electronic circuits	No	• Lamp load	Max. 8 Hz
Input voltage		Short-circuit protection	Yes
• Rated value	24 V DC	Load current	
• For "0" signal	– 30 V to 5 V	• Total current	Max. 2 A
• For "1" signal	13 V to 30 V	Lamp load	Max. 5 W
		Setting a digital input	Possible
		Limitation of voltage induced on current interruption	Typ. (L3+) – 55 V
		Cable length	Max. 100 m (328 ft.)

\* Only relevant when operating with the IM 308-C.





## Electronics Blocks ET 200B-24DI/8DO (6ES7 133-0BN00-0XB0) and ET 200B-24DI/8DO 0.2 ms (6ES7 133-0BN10-0XB0), continued

### Schematic Circuit Diagram

Simplified diagram of the potential for the ET 200B-24DI/8DO or ET 200B-24DI/8DO 0.2 ms and TB2/DC or TB4/DC:

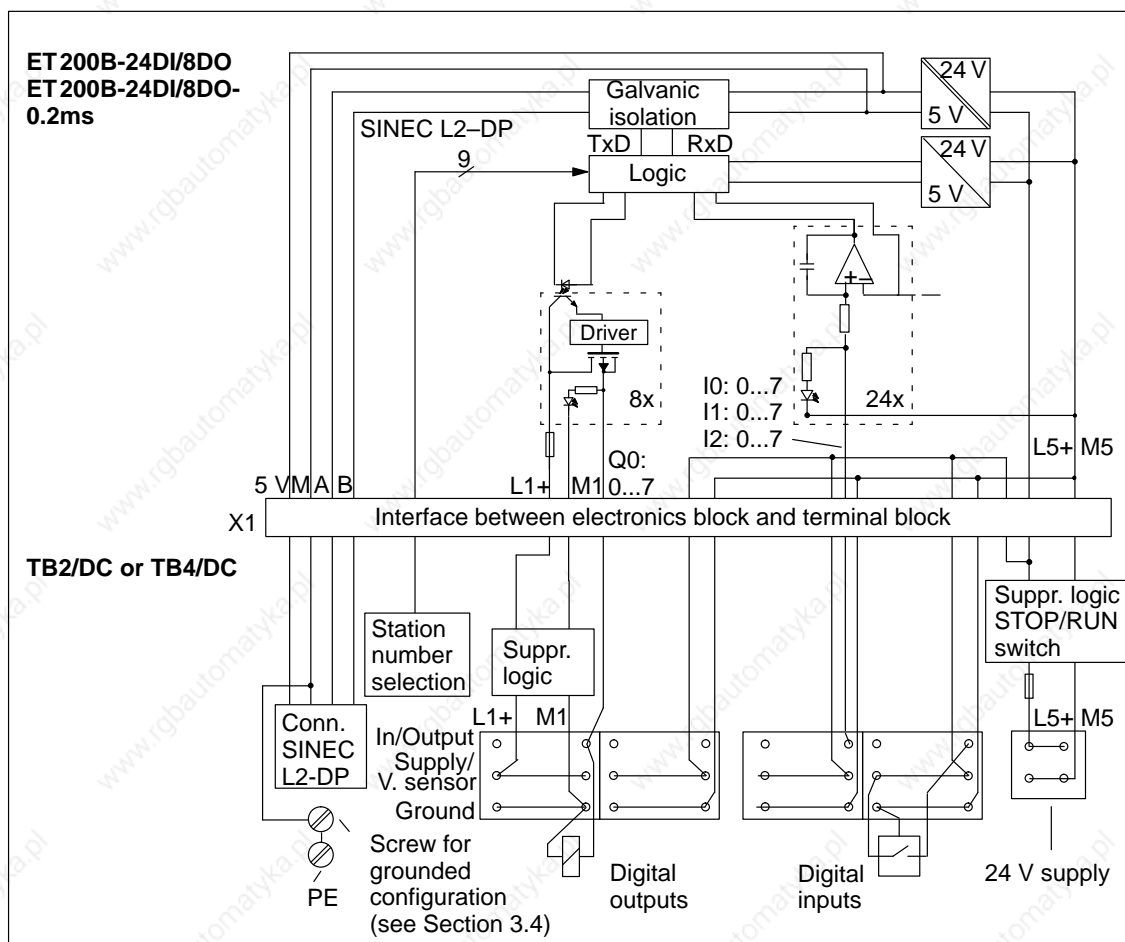

Figure 8-36 Schematic Circuit Diagram: ET 200B-24DI/8DO (6ES7 133-0BN00-0XB0) or ET 200B-24DI/8DO 0.2 ms (6ES7 133-0BN10-0XB0) and TB2/DC or TB4/DC

**Schematic Circuit Diagram**

Simplified diagram of the potential for the ET 200B-24DI/8DO or ET 200B-24DI/8DO 0.2 ms and TB2-4/DC:

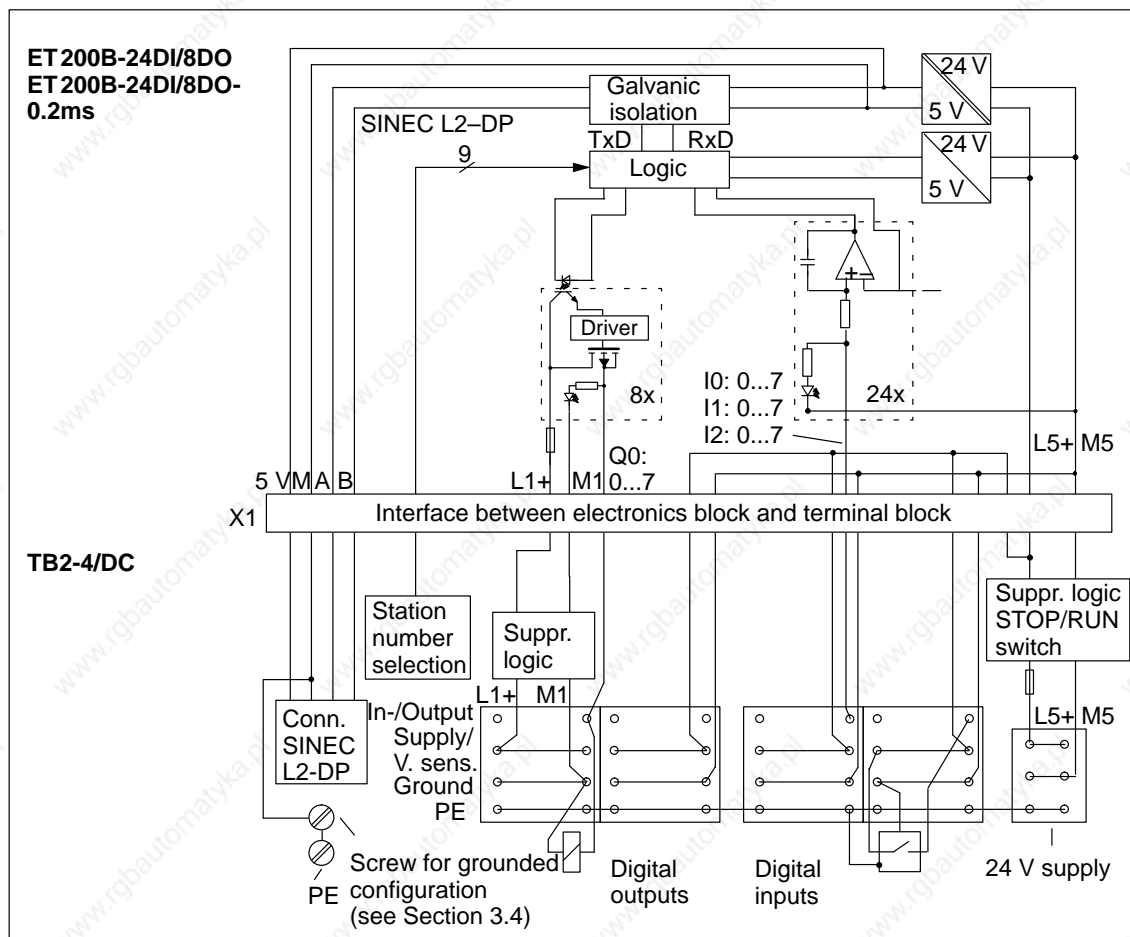

Figure 8-37 Schematic Circuit Diagram: ET 200B-24DI/8DO (6ES7 133-0BN00-0XB0) or ET 200B-24DI/8DO 0.2 ms (6ES7 133-0BN10-0XB0) and TB2-4/DC

**Note**

The connection terminals for PE on the 4-tier terminal block are not connected to the PE terminal of the TB2-4/DC terminal block.

## Electronics Blocks ET 200B-24DI/8DO (6ES7 133-0BN00-0XB0) and ET 200B-24DI/8DO 0.2ms (6ES7 133-0BN10-0XB0), continued

### Terminal Assignments

The ET 200B-24DI/8DO and ET 200B-24DI/8DO 0.2ms can be plugged into the TB2/DC, TB2-4/DC or TB4/DC.

Table 8-10 contains the terminal assignments of the terminal blocks for the ET 200B-24DI/8DO and ET 200B-24DI/8DO 0.2ms:

Table 8-10 Terminal Assignments of Terminal Blocks TB2/DC, TB2-4/DC and TB4/DC for ET 200B-24DI/8DO (6ES7 133-0BN00-0XB0) and ET 200B-24DI/8DO 0.2ms (6ES7 133-0BN10-0XB0)

Terminal	Assignment
1 to 8	Q0: Outputs .0 to .7
9 to 16	I0: Inputs .0 to .7
17 to 24	I1: Inputs .0 to .7
25 to 32	I2: Inputs .0 to .7
33 to 40	Power supply L1+ for channel group Q0: .0 to .7
41 to 64	24 V (sensor supply)
65 to 72	Ground M1 for channel group Q0: .0 to .7
73 to 96	Ground (sensor supply)
34 terminals  (TB2-4/DC only)	PE (internally jumpered, but not connected to PE screw) (TB2-4/DC only)
L5+	Power supply of the internal logic <b>and</b> 24 V sensor supply
L5+	Power supply of the internal logic <b>and</b> 24 V sensor supply
M5	Ground connection of the internal logic <b>and</b> 24 V sensor supply
M5	Ground connection of the internal logic <b>and</b> 24 V sensor supply

### Note

If all actuators have 2-wire connections to TB2/DC or TB4/DC, terminate for each group the ground connection of one actuator and the incoming reference potential line via a terminal pin in accordance with DIN 46231.

L1+/L5+ and M1/M5 are **not** connected to each other.

L5+ and terminals 41 to 64 are connected to each other, as are M5 and terminals 73 to 96.

Technical specifications		Inputs, continued	
Baud rates	9.6/19.2/93.75/187.5/500/1500/3000*/6000*/12000* kbps	Delay of inputs for 6ES7 133-0BN00-0XB0	3 ms
Bus protocol	DP Standard	Delay of inputs for 6ES7 133-0BN10-0XB0	0.2 ms
FREEZE and SYNC capability	Yes*	Connection of 2-wire BERO	Possible
Galvanic isolation SINEC L2-DP bus	Yes	• Quiescent current	≤ 1.5 mA
Power losses	Max. 5.5 W	Connection of mechanical switches	Possible
Weight (EB and TB)	Approx. 800 g (28 oz.)	Cable length of sensors	
Dimensions (EB and TB): W x H x D)	235 x 130 x 60 mm (9.17 x 5.07 x 2.34 in.)	• Unshielded	Max. 100 m (328 ft.)
Diagnostics functions		Outputs	
Voltage monitoring	Green "RUN" LED	Number of outputs	8
Bus monitoring SINEC L2-DP	Red "BF" LED	Galvanic isolation	Yes
Group diagnostics for short-circuit, load voltage failure	Red "DIA" LED	• In groups of	8
Load voltage monitoring	Green "L1+" LED	Output voltage	
Status of inputs and outputs	Green LEDs	• For "0" signal	Max. 2 V (idle)
		• For "1" signal	Min. (supply voltage – 3 V)
Supply voltage for sensor supply, load voltage supply and internal logic		Output current	
Supply voltage (L1+,L5+)		• For "0" signal	Max. 1 mA
• Rated value	24 V DC	• For "1" signal	Max. 0.5 A
• Permissible range	18.5 to 30.2 V	Delay of outputs	
• Value for $t < 0.5$ s	35 V	• From "0" to "1"	Approx. 20 $\mu$ s
Current consumption from L5+		• From "1" to "0"	Max. 0.5 ms
• Logic	Typ. 85 mA	Switching frequency	
• Sensors	Max. 1 A	• Resistive load	Max. 1000 Hz
$I^2t$ (for the inrush current)	≤ 0.05 A <sup>2</sup> s	• Inductive load	Max. 0.5 Hz
		• Lamp load	Max. 8 Hz
Inputs		Short-circuit protection	Yes
Number of inputs	24	Load current	
Galvanic isolation to internal electronic circuits	No	• Total current	Max. 2 A
Input voltage		Lamp load	Max. 5 W
• Rated value	24 V DC	Setting a digital input	Possible
• For "0" signal	– 30 V to 5 V	Limitation of voltage induced on current interruption	Typ. (L5+) – 55 V
• For "1" signal	13 V to 30 V	Cable length	Max. 100 m (328 ft.)
Input current for "1" signal	Typ. 4 mA at 24 V Min 2 mA		

\* Only relevant when operating with the IM 308-C.

### 8.1.12 Electronics Block ET 200B-16DI-AC (6ES7 131-0HF00-0XB0)

**Characteristics**

The ET 200B-16DI-AC electronics block has the following features:

- 16 inputs, floating in groups of 4
- Input voltage: 120/230 V AC
- Suitable for switches and 2-wire proximity switches acc. to IEC 1131, type 1

**Dimension Drawing**

See Figure 8-17 for the precise dimensions.

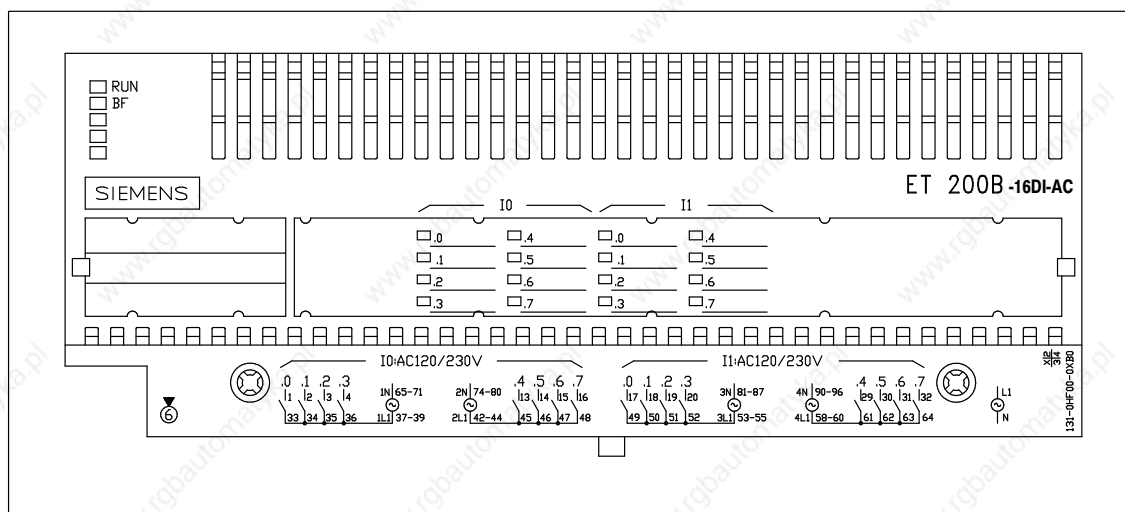

Figure 8-38 Front Elevation: ET 200B-16DI-AC (6ES7 131-0HF00-0XB0)

**Schematic Circuit Diagram**

Simplified diagram of the potential for the ET 200B-16DI-AC and TB6/AC:

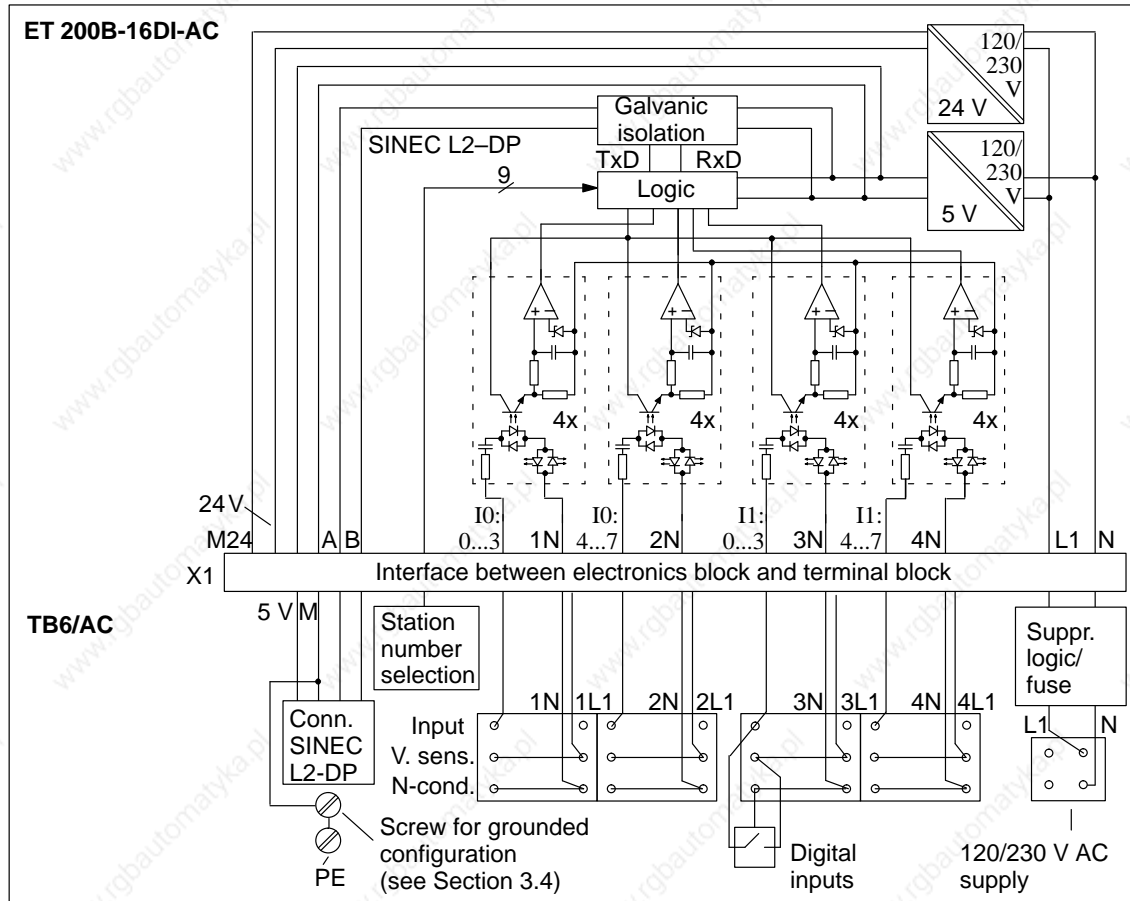

Figure 8-39 Schematic Circuit Diagram: ET 200B-16DI-AC (6ES7 131-0HF00-0XB0) and TB6/AC

## Electronics Block ET 200B-16DI-AC (6ES7 131-0HF00-0XB0), continued

### Terminal Assignments

The ET 200B-16DI-AC can be plugged into the TB6/AC.

Table 8-11 contains the terminal assignments of the TB6/AC terminal block for the ET 200B-16DI-AC:

Table 8-11 Terminal Assignments of Terminal Block TB6/AC for ET 200B-16DI-AC (6ES7 131-0HF00-0XB0)

Terminal	Assignment
1 ... 4	I0: Inputs .0 ... .3
13 ... 16	I0: Inputs .4 ... .7
17 ... 20	I1: Inputs .0 ... .3
29 ... 32	I1: Inputs .4 ... .7
33 ... 39	Sensor supply 1L1 for channel I0: .0 ... .3
42 ... 48	Sensor supply 2L1 for channel I0: .4 ... .7
49 ... 55	Sensor supply 3L1 for channel I1: .0 ... .3
58 ... 64	Sensor supply 4L1 for channel I1: .4 ... .7
65 ... 71	Sensor supply 1N for channel I0: .0 ... .3
74 ... 80	Sensor supply 2N for channel I0: .4 ... .7
81 ... 87	Sensor supply 3N for channel I1: .0 ... .3
90 ... 96	Sensor supply 4N for channel I1: .4 ... .7
L1	Power supply for the internal logic
N	Power supply for the internal logic

Technical specifications		Inputs	
Baud rates	9,6/19,2/93,75/187,5/500/ 1500/3000*/6000*/ 12000* kbps	Number of inputs	16
Bus protocol	DP-Standard	Galvanic isolation	Yes (Optokoppler)
Galvanic isolation to SINEC L2-DP	Yes, 500 V DC to logic, 1500 V AC to connection terminals	• In groups of	4
Power losses		Input voltage	
• at 230 V	Typ. 6 W	• Rated value	120/230 V AC
• at 120 V	Typ. 4.5 W	• For "0" signal	0 to 40 V AC
Weight (EB and TB)	811 g (29 oz.)	• For "1" signal	79 to 264 V AC
Dimensions (EB and TB): W x H x D)	235 x 130 x 60 mm (9.17 x 5.07 x 2.34 in.)	Input current for "1" signal	3 to 16 mA
<b>Diagnostics functions</b>		• At 120 V, 60 Hz	Typ. 6,5 mA
Voltage monitoring	Green "RUN" LED	• At 230 V, 50 Hz	Typ. 10,5 mA
Bus monitoring SINEC L2-DP	Red "BF" LED	Type of input acc. to IEC 1131	Type 1
Status of inputs	Green LEDs	Delay of inputs	0 to 25 ms
<b>Supply voltage for internal logic</b>		Connection of 2-wire BERO	No
Supply voltage L1		• Permissible quiescent current	2 mA
• Rated value	120/230 V AC	Connection of mechanical switches	Yes
• Permissible range	85 to 264 V AC	Cable length	Max. 600 m (1968 ft)
• Frequency	47 to 63 Hz		
• Current consumption from L1	Typ. 60 mA		
<b>Note:</b>			
If the module is installed in a 230 V AC system, the following must each be connected to the same phase:			
• 1L1/1N and 2L1/2N (same phase)			
• 3L1/3N and 4L1/4N (same phase)			
<b>Restriction:</b>			
If the module is installed in a 230 V AC system with ambient temperatures higher than 40 °C (104 °F), only 12 inputs are allowed to be used and the rated input voltage must not exceed 240 V AC.* Only relevant when operating with the IM 308-C.			

\* Only relevant when operating with the IM 308-C.



### 8.1.13 Electronics Block ET 200B-16DO-AC (6ES7 132-0HF00-0XB0)

**Characteristics**

The ET 200B-16DO-AC electronics block has the following features:

- 16 outputs, floating in groups of 4
- Output current: 0.5 A
- Load voltage: 120/230 V AC

**Dimension Drawing**

See Figure 8-17 for the precise dimensions.

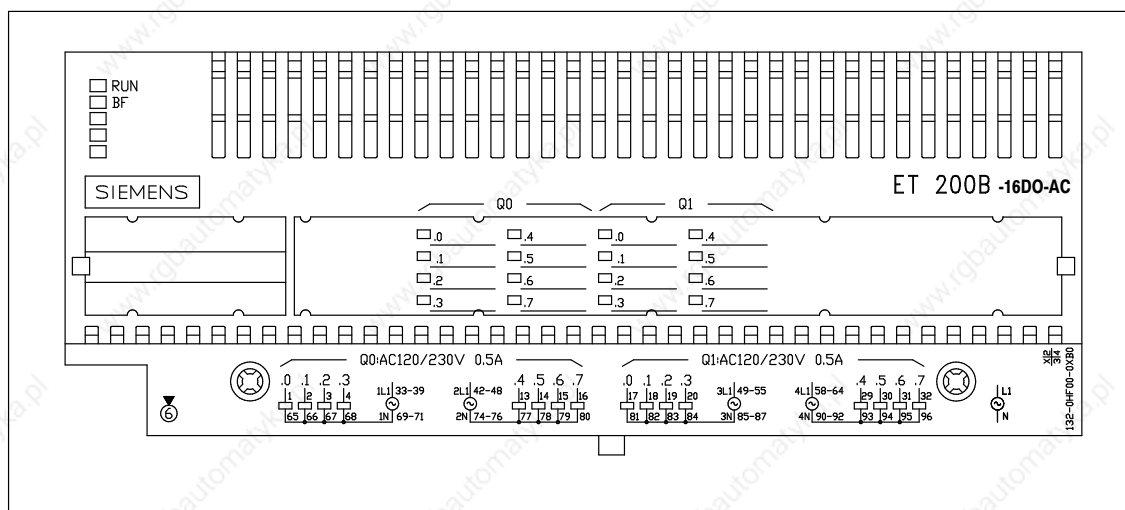

Figure 8-40 Front Elevation: ET 200B-16DO-AC (6ES7 132-0HF00-0XB0)

**Schematic Circuit Diagram**

Simplified diagram of the potential for the ET 200B-16DO-AC and TB6/AC:

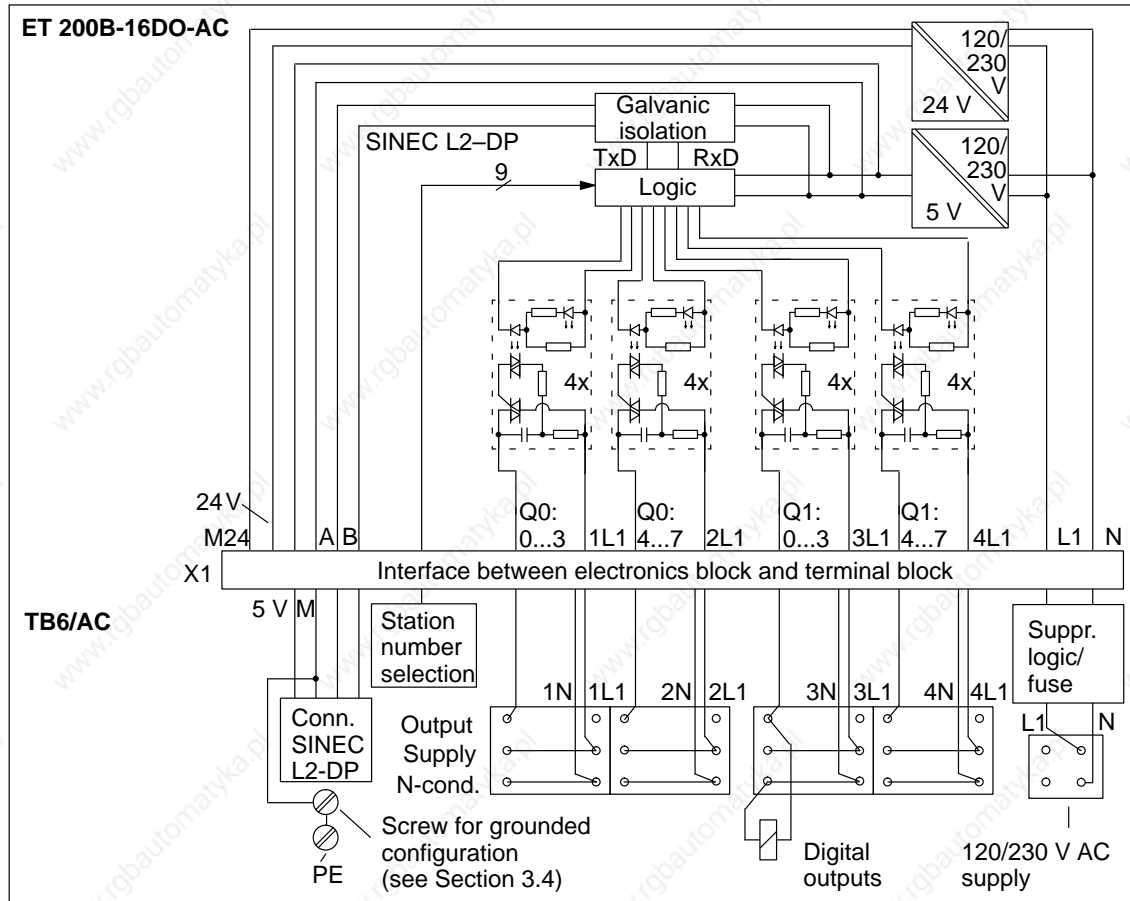

Figure 8-41 Schematic Circuit Diagram: ET 200B-16DO-AC (6ES7 132-0HF00-0XB0) and TB6/AC

## Electronics Block ET 200B-16DO-AC (6ES7 132-0HF00-0XB0), continued

### Terminal Assignments

ET 200B-16DO-AC can be plugged into the TB6/AC.

Table 8-12 contains the terminal assignments of the TB6/AC terminal block for the ET 200B-16DO-AC:

Table 8-12 Terminal Assignments of Terminal Block TB6/AC for ET 200B-16DO-AC (6ES7 132-0HF00-0XB0)

Terminal	Assignment
1 ... 4	Q0: Outputs .0 ... .3
13 ... 16	Q0: Outputs .4 ... .7
17 ... 20	Q1: Outputs .0 ... .3
29 ... 32	Q1: Outputs .4 ... .7
33 ... 39	Sensor supply 1L1 for channel Q0: .0 ... .3
42 ... 48	Sensor supply 2L1 for channel Q0: .4 ... .7
49 ... 55	Sensor supply 3L1 for channel Q0: .0 ... .3
58 ... 64	Sensor supply 4L1 for channel Q0: .4 ... .7
65 ... 71	Sensor supply 1N for channel Q1: .0 ... .3
74 ... 80	Sensor supply 2N for channel Q1: .4 ... .7
81 ... 87	Sensor supply 3N for channel Q1: .0 ... .3
90 ... 96	Sensor supply 4N for channel Q1: .4 ... .7
L1	Power supply for the internal logic
N1	Power supply for the internal logic

Technical specifications		Outputs	
Baud rates	9,6/19,2/93,75/187,5/500/ 1500/3000*/6000*/ 12000* kbps	Number of outputs	16
Bus protocol	DP-Norm	Galvanic isolation	Yes (optocouplers)
Galvanic isolation to SI- NEC L2-DP bus	Yes, 500 V DC to logic, 1500 V AC to connection terminals	• In groups of	4
Power losses	Max. 11 W	• Signal voltage	79 to 264 V AC
Weight (EB and TB)	Approx. 805 g (29 oz)	Output voltage	
Dimensions (EB and TB): W x H x D)	235 x 130 x 60 mm (9.17 x 5.07 x 2.34 in.)	• For "1" Signal (≥ 50 mA)	Max. L1 – 1,5 V
		• For "1" Signal (≤ 50 mA)	Max. L1 – 8,5 V
		Output current	
		• For "0" signal	Max. 1,3 mA
		Delay of outputs	Max. 20 ms
		Short-circuit protection	No
		Switching frequency	
		• Resistive load	10 Hz
		• Inductive load	0,5 Hz
		• Lamp load	1 Hz
		Load current per output in preferred mounting position	
		• 0 °C to 40 °C (32 ° F to 104 ° F)	0,5 A
		• 40 °C to 60 °C (32 ° F to 140 ° F)	0,35 A
		Load current per output in other mounting positions	
		• 0 °C to 40 °C (32 ° F to 104 ° F)	0,35 A
		Lamp load	Max. 25 W
		Size of motor starter	Max. size 3 acc. to NEMA
		Parallel connection of 2 outputs	Possible (though not in order to increase power)
		Setting a digital input	Possible
		Cable length	Max. 600 m (1968 ft)
Diagnostics functions			
Voltage monitoring	Green "RUN" LED		
Bus monitoring SINEC L2-DP	Red "BF" LED		
Group diagnostics for short-circuit, load voltage failure	No		
Load voltage monitoring	No		
Status of outputs	Green LEDs		
Supply voltage for internal logic			
Supply voltage L1			
• Rated value	120/230 V AC		
• Permissible range	85 to 264 V AC		
• Frequency	47 to 63 Hz		
• Current consumption from L1	Typ. 150 mA		
<b>Note:</b>			
If the module is installed in a 230 V AC system, the following must each be connected to the same phase:			
• 1L1/1N and 2L1/2N (same phase)			
• 3L1/3N and 4L1/4N (same phase)			

\* Only relevant when operating with the IM 308-C.

### 8.1.14 Electronics Block ET 200B-16RO-AC (6ES7 132-0HH00-0XB0)

#### Characteristics

The ET 200B-16RO-AC electronics block has the following features:

- 16 relay outputs, floating in groups of 1
- Load voltage: 120/230 V AC  
24 ... 150 V DC
- Output current: 4A for outputs 0.0, 0.7, 1.0 and 1.7  
12 A for outputs 0.1 to 0.6 and 1.1 to 1.6
- Suitable for AC/DC solenoid valves, switches, motor starters, small-power motors, motors and lamps.

#### Dimension Drawing

See Figure 8-17 for the precise dimensions.

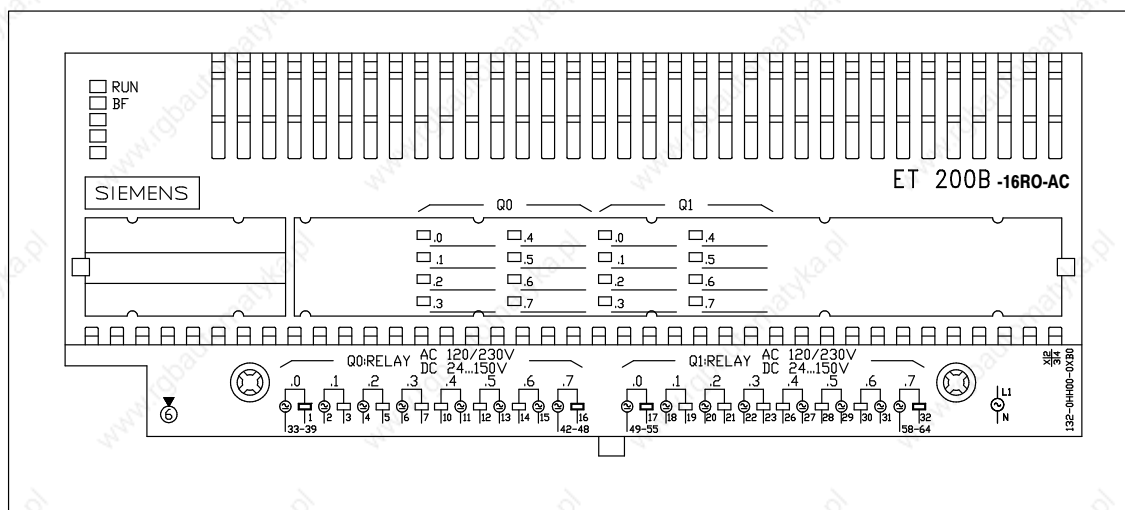

Figure 8-42 Front Elevation: ET 200B-16RO-AC (6ES7 132-0HH00-0XB0)

**Schematic Circuit Diagram**

Simplified diagram of the potential for the ET 200B-16RO-AC and TB6/DC:

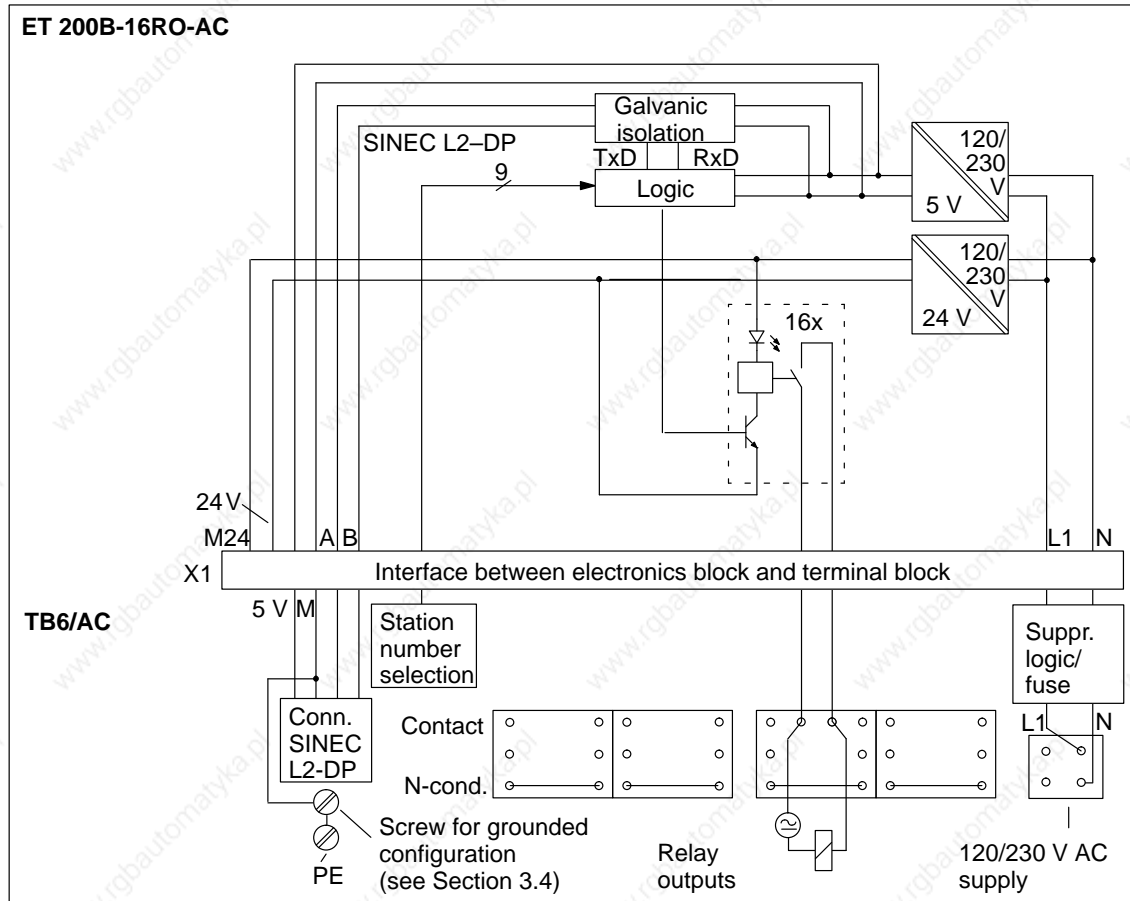

Figure 8-43 Schematic Circuit Diagram: ET 200B-16RO-AC (6ES7 132-0HH00-0XB0) and TB6/AC

## Electronics Block ET 200B-16RO-AC (6ES7 132-0HH00-0XB0), continued

### Terminal Assignments

The ET 200B-16RO-AC can be plugged into the TB6/AC.

Table 8-13 contains the terminal assignments of the TB6/AC terminal block for the ET 200B-16RO-AC:

Table 8-13 Terminal Assignments of Terminal Block TB6/AC for ET 200B-16RO-AC (6ES7 132-0HH00-0XB0)

Terminal	Assignment
33 ... 39	Q0: Output 0/0
1	Q0: Output 0/1
2	Q0: Output 1/0
3	Q0: Output 1/1
4	Q0: Output 2/0
5	Q0: Output 2/1
6	Q0: Output 3/0
7	Q0: Output 3/1
10	Q0: Output 4/1
11	Q0: Output 4/0
12	Q0: Output 5/1
13	Q0: Output 5/0
14	Q0: Output 6/1
15	Q0: Output 6/0
16	Q0: Output 7/1
42 ... 48	Q0: Output 7/0
49 ... 55	Q1: Output 0/0
17	Q1: Output 0/1
18	Q1: Output 1/0
19	Q1: Output 1/1
20	Q1: Output 2/0
21	Q1: Output 2/1
22	Q1: Output 3/0
23	Q1: Output 3/1
26	Q1: Output 4/1
27	Q1: Output 4/0
28	Q1: Output 5/1
29	Q1: Output 5/0
30	Q1: Output 6/1

Table 8-13 Terminal Assignments of Terminal Block TB6/AC for ET 200B-16RO-AC (6ES7 132-0HH00-0XB0)

Terminal	Assignment
31	Q1: Output 6/0
32	Q1: Output 7/1
58 ... 64	Q1: Output 7/0
L1	Power supply of the internal logic
N	Power supply of the internal logic



## Electronics Block ET 200B-16RO-AC (6ES7 132-0HH00-0XB0), continued

Technical specifications		Relay outputs	
Baud rates	9,6/19,2/93,75/187,5/500/ 1500/3000*/6000*/ 12000* kbps	Number of outputs	
Bus protocol	DP Standard	• High current	4 (0.0, 0.7, 1.0 and 1.7)
Galvanic isolation to SI- NEC L2-DP bus	Yes, 500 V DC to logic, 1500 V AC to connection terminals	• Low current	12 (0.1 to 0.6, 1.1 to 1.6)
Power losses	20 W	Galvanic isolation	Yes (relays)
Weight (EB and TB)	814 g (29 oz)	• In groups of	1
Dimensions (EB and TB: W x H x D)	235 x 130 x 60 mm (9.17 x 5.09 x 2.34 in.)	Short-circuit protection	No
<b>Diagnostics functions</b>		Relay type	Takamisawa NY 24 W-K
Voltage monitoring	Green "RUN" LED	Output voltage	
Bus monitoring SINEC L2-DP	Red "BF" LED	• Rated value	24 to 150 V DC 120/230 V AC
Group diagnostics for short-circuit, load voltage failure	No	• Permissible range	0,1 to 150 V DC 79 to 264 V AC
Load voltage monitoring	No	Continuous current $I_{th}$	Max. 4 A (for high current points) Max. 2 A (for low current points)
Status of outputs	Green LEDs	Switching capacity of con- tacts	
<b>Supply voltage for internal logic</b>		• High current points	
Supply voltage L1		Resistive load	0 to 40 °C      60 °C (32 to 104 ° F)    (140° F)
• Rated value	120/230 V AC	24 V DC/ 120/230 V AC	4 A              2 A
• Permissible range	85 to 264 V AC	120 V DC	0,2 A            0,2 A
• Frequency	47 to 63 Hz	Inductive load	
• Current consumption from L1	Typ. 210 mA	24 V DC/ 120/230 V AC	2 A              2 A
<b>Note:</b>		120 V DC	0,2 A            0,2 A
Protect the module against inductive overvoltages at the relay contacts. Use an RC element or a varistor, switched either via the relay contact or via the load, as the over-voltage protection device. The size and values of the components must be chosen according to the magnitude and type of the load. Overvoltage protection devices increase the service life of the relay contacts.		• Low current points	
<b>Note:</b>		Resistive and inductive loads	0 to 40 °C      60 °C (32 to 104 ° F)    (140° F)
If the module is installed in a 230 V AC system, all the outputs belonging to a particular channel group (Q0, Q1) must be connected to the same phase.		24 V DC/ 120/230 V AC	2 A              1 A
		120 V DC	0,2 A            0,2 A
		Switching cycles of con- tacts acc. to VDE 0660, Part 200	
		• DC-11	> 100 x 10 <sup>6</sup>
		• AC-15	> 300 x 10 <sup>5</sup>
		Switching frequency	
		• Resistive load	Max. 10 Hz
		• Inductive load	Max. 2 Hz
		Cable length	Max. 600 m (1968 ft.)
		Setting a digital input	Possible

\* Only relevant when operating with the IM 308-C.

### 8.1.15 Electronics Block ET 200B-8DI/8RO-AC (6ES7 133-0HH00-0XB0)

#### Characteristics

The ET 200B-8DI/8RO-AC electronics block has the following features:

- 8 inputs, floating in groups of 4  
8 relay outputs, floating in groups of 1
- Input voltage: 120/230 V AC
- Inputs suitable for switches and 2-wire proximity switches acc. to IEC 1131, type 1
- 8 relay outputs, floating in groups of 1
- Output load voltage: 120/230 V AC  
24 ... 150 V DC
- Output current: 4 A for outputs 0.0 and 0.7  
2 A for outputs 0.1 to 0.6
- Outputs suitable for AC/DC solenoid valves, switches, motor starters, small-power motors, motors and lamps.

#### Dimension Drawing

See Figure 8-17 for the precise dimensions.

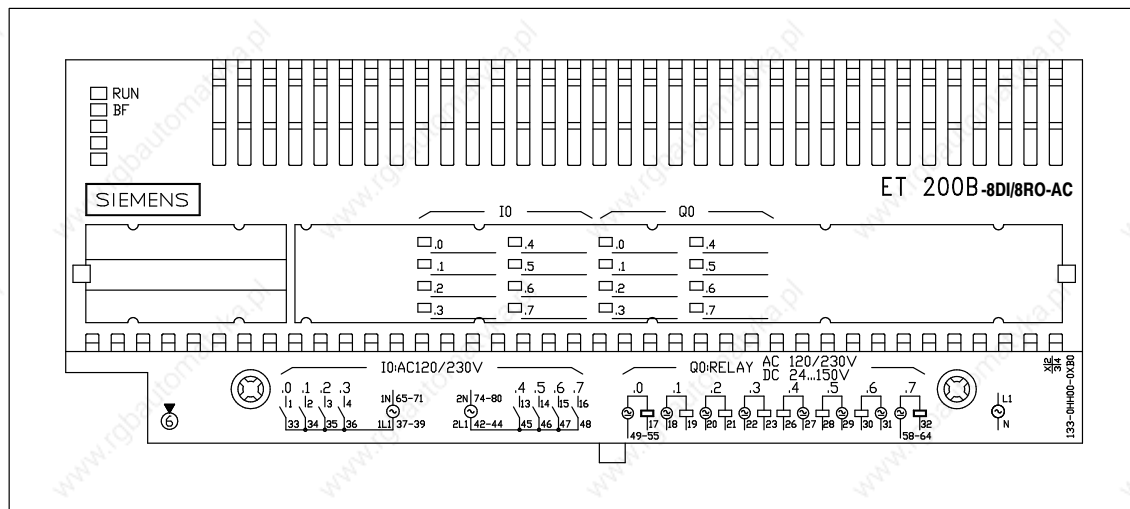

Figure 8-44 Front Elevation: ET 200B-8DI/8RO-AC (6ES7 133-0HH00-0XB0)

**Electronics Block ET 200B-8DI/8RO-AC (6ES7 133-0HH00-0XB0),  
continued**

**Schematic Circuit  
Diagram**

Simplified diagram of the potential for the ET 200B-8DI/8RO-AC and TB6/DC:

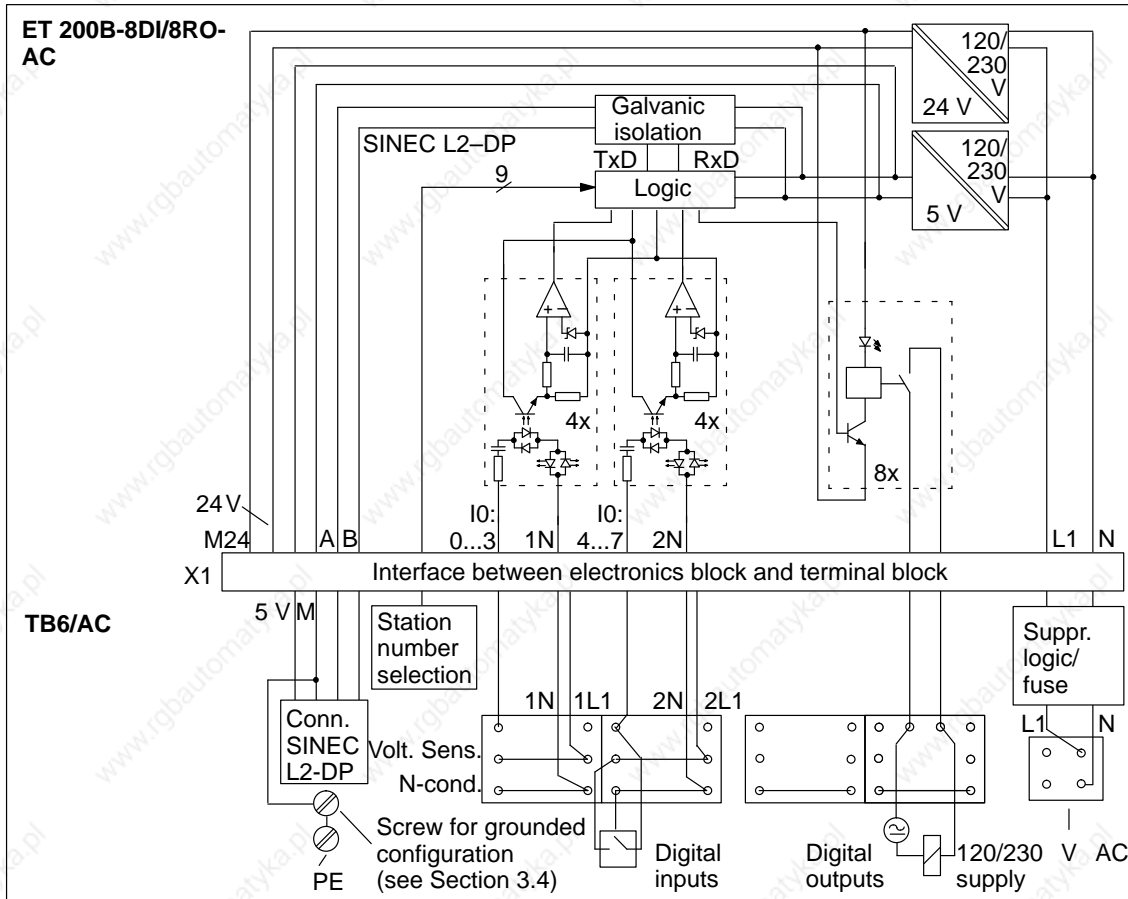

Figure 8-45 Schematic Circuit Diagram: ET 200B-8DI/8RO-AC (6ES7 133-0HH00-0XB0) and TB6/AC

## Terminal Assignments

The ET 200B-8DI/8RO-AC can be plugged into the TB6/AC.

Table 8-14 contains the terminal assignments of the TB6/AC terminal block for the ET 200B-8DI/8RO-AC:

Table 8-14 Terminal Assignments of Terminal Block TB6/AC for ET 200B-8DI/8RO-AC (6ES7 133-0HH00-0XB0)

Terminal	Assignment
1 ... 4	I0: Inputs .0 ... .3
13 ... 16	I0: Inputs .4 ... .7
33 ... 39	Sensor supply 1L1 for channel I0: .0 ... .3
42 ... 48	Sensor supply 2L1 for channel I0: .4 ... .7
65 ... 71	Sensor supply 1N for channel I0: .0 ... .3
74 ... 80	Sensor supply 2N for channel I0: .4 ... .7
49 ... 55	Q0: Output 0/0
17	Q0: Output 0/1
18	Q0: Output 1/0
19	Q0: Output 1/1
20	Q0: Output 2/0
21	Q0: Output 2/1
22	Q0: Output 3/0
23	Q0: Output 3/1
26	Q0: Output 4/1
27	Q0: Output 4/0
28	Q0: Output 5/1
29	Q0: Output 5/0
30	Q0: Output 6/1
31	Q0: Output 6/0
32	Q0: Output 7/1
58 ... 64	Q0: Output 7/0
L1	Power supply of the internal logic
N	Power supply of the internal logic

## Electronics Block ET 200B-8DI/8RO-AC (6ES7 133-0HH00-0XB0), continued

Technical specifications		Inputs	
Baud rates	9,6/19,2/93,75/187,5/500/ 1500/3000*/6000*/ 12000* kBaud	Number of inputs	8
Bus protocol	DP Standard	Galvanic isolation	Yes (optocouplers)
Galvanic isolation to SI- NEC L2-DP bus	Yes, 500 V DC to logic, 1500 V AC to connection terminals	• In groups of	4
Power losses	13 W	Input voltage	
Weight (EB and TB)	811 g (29 oz)	• Rated value	120/230 V AC
Dimensions (EB and TB: W x H x D)	235 x 130 x 60 mm (9.17 x 5.07 x 2.34 in.)	• For "0" signal	0 to 40 V AC
		• For "1" signal	79 to 264 V AC
		Input current for "1" sig- nal	3 to 16 mA
		• at 120, 60 Hz	Typ. 6,5 mA
		• at 230 V, 50 Hz	Typ. 10,5 mA
		Type of input acc. to IEC 1131	Type 1
		Delay of inputs	0 to 25 ms
		Connection of 2-wire BERO	No
		• Permissible quiescent current	2 mA
		Connection of mechanical switches	Yes
		Cable length of sensors	
		Cable length	Max. 600 m (1968 ft.)
Diagnostics functions			
Voltage monitoring	Green LED "RUN"		
Bus monitoring SINEC L2-DP	Red LED "BF"		
Group diagnostics for short-circuit, load voltage failure	No		
Load voltage monitoring	No		
Status of outputs	Green LEDs		
Supply voltage for internal logic			
Supply voltage L1			
• Rated value	120/230 V AC,		
• Permissible range	85 to 264 V AC		
• Frequency	47 to 63 Hz		
• Current consumption from L1	Typ. 165 mA		
<b>Restriction:</b>			
If the module is installed in a 230 V AC system with ambient temperatures higher than 40 °C (104 °F), only 6 inputs are allowed to be used and the rated input voltage must not exceed 240 V AC.			
<b>Note:</b>			
If the module is installed in a 230 V AC system, the following must each be connected to the same phase:			

\* Only relevant when operating with the IM 308-C.

Relay outputs		Relay outputs, continued	
Number of outputs		Switching cycles of contacts acc. to VDE 0660, Part 200	
• High current	2 (0.0, 0.7)	• DC-11	> 100 x 10 <sup>6</sup>
• Low current	6 (0.1 to 0.6)	• AC-15	> 300 x 10 <sup>5</sup>
Galvanic isolation	Yes (relays)	Switching frequency	
• In groups of	1	• Resistive load	Max. 10 Hz
Short-circuit protection	No	• Inductive load	Max. 2 Hz
Relay type	Takamisawa NY 24W-K	Cable length	Max. 600 m (1968 ft.)
Output voltage		Setting a digital input	Possible
• Rated value	24 to 150 V DC 120/230 V AC	<b>Note:</b>	
• Permissible range	0,1 to 150 V DC 79 to 264 V AC	Protect the module against inductive overvoltages at the relay contacts. Use an RC element or a varistor, switched either via the relay contact or via the load, as the overvoltage protection device. The size and values of the components must be chosen according to the magnitude and type of the load.	
Continuous current I <sub>th</sub>	Max. 4 A (for high current points) Max. 2 A (for low current points)	Overvoltage protection devices increase the service life of the relay contacts.	
Switching capacity of contacts		<b>Note:</b>	
• High current points		If the module is installed in a 230 V AC system, all the outputs belonging to a particular channel group (Q0, Q1) must be connected to the same phase.	
Resistive load	0 to 40 °C      60 °C (32 to 104 ° F)    (140° F)		
24 V DC/ 120/230 V AC	4 A                      2 A		
120 V DC	0,2 A                    0,2 A		
Inductive load			
24 V DC/ 120/230 V AC	2A                        2A		
120 V DC	0,2 A                    0,2 A		
• Low current points			
Resistive and inductive loads	0 to 40 °C      60 °C (32 to 104 ° F)    (140° F)		
24 V DC/ 120/230 V AC	2A                        1 A		
120 V DC	0.2 A                    0.2 A		

# Analog Modules

# 9

## **In this Chapter**

This chapter contains the technical specifications of the analog ET 200B modules.

In addition to the technical specifications, this chapter also describes the measuring principles and the measured value representation for the analog modules.

## 9.1 Analog Modules

### Introduction

There are analog modules available for connecting analog current sensors, voltage sensors or loads.

The tables below give an overview of the ET 200B analog modules.

### List of Electronics Blocks

The following types of electronics blocks are available:

Table 9-1 Analog Electronics Blocks of the ET 200B

Electronics Block	Order No.	Description
ET 200B-4/8AI	6ES7 134-0KH00-0XB0	8 analog differential inputs <b>or</b> 4 x Pt 100 (measuring principle: integrating)
ET 200B-4AI	6ES7 134-0HF00-0XB0	4 analog differential inputs (measuring principle: successive approximation)
ET 200B-4AO	6ES7 135-0HF00-0XB0	4 analog outputs

### List of Terminal Blocks

A terminal block is available for all analog electronics blocks:

Table 9-2 Analog Terminal Block of the ET 200B

Terminal Block	Order No.	Description
TB8	6ES7 193-0CD40-0XA0	4/8-channel, spring-loaded terminal



## 9.1.1 Setting and Parameterizing the Analog Modules

### Introduction

You can set the function of the analog modules

- via the COM ET 200 parameterization software and
- via the coding plugs on the TB8 terminal block.

### Where to Find a Description

Parameterization of the analog modules using COM ET 200 V 4.x is described in detail in Section 4.2.

COM ET 200 WINDOWS also provides extensive support for parameterizing the ET 200B-4/8AI with COM ET 200 WINDOWS through its integrated help system.

Please refer to the *ET 200 Distributed I/O System* manual (Order No. 6ES5 998-3ES12) for further information about how to use COM ET 200 WINDOWS.

Below, you will learn how to set the coding plugs.

### Coding Plugs

The TB8 terminal block has a coding plug for each channel or channel group (0, 1, 2, 3,) and one for setting the compensation.

You use the coding plugs to define the input or output circuit of the TB8 depending on the measured value sensor/load connected and on the desired measuring principle.

The coding plugs can be set to: “A”, “B”, “C” and “D”.

The assignment of coding plug settings to measuring principle or measured value sensor/load can be found in the sections dealing with the individual electronics blocks (see Sections 9.1.3 to 9.1.5).

## Setting and Parameterizing the Analog Modules, continued

### Setting the Coding Plug

Proceed as follows if you want to change the setting of the coding plug:

1. Remove the coding plug from the TB8 via the channel group (1).

**Tip:**

The coding plugs can be adjusted more easily before the electronics block is hung into place.

2. Turn the coding plug to the desired setting (2) and insert it back into place (3).

**Correct Setting:**

The nose “Δ” next to the letter “A”, “B”, “C” or “D” must point in the direction of the electronics block.

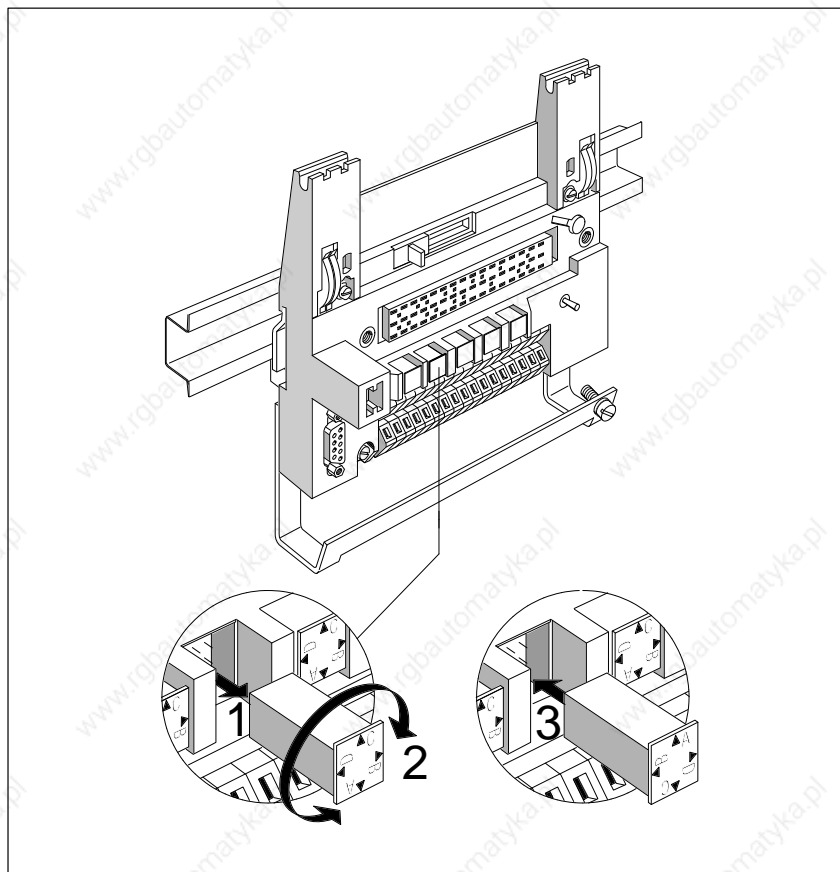

Figure 9-1 Changing the Setting of the Coding Plug

### 9.1.2 TB8 Terminal Block (6ES7 193-0CD40-0XA0)

**Dimension Drawing TB8**

Dimension Drawing: TB8 terminal block (spring-loaded terminal)

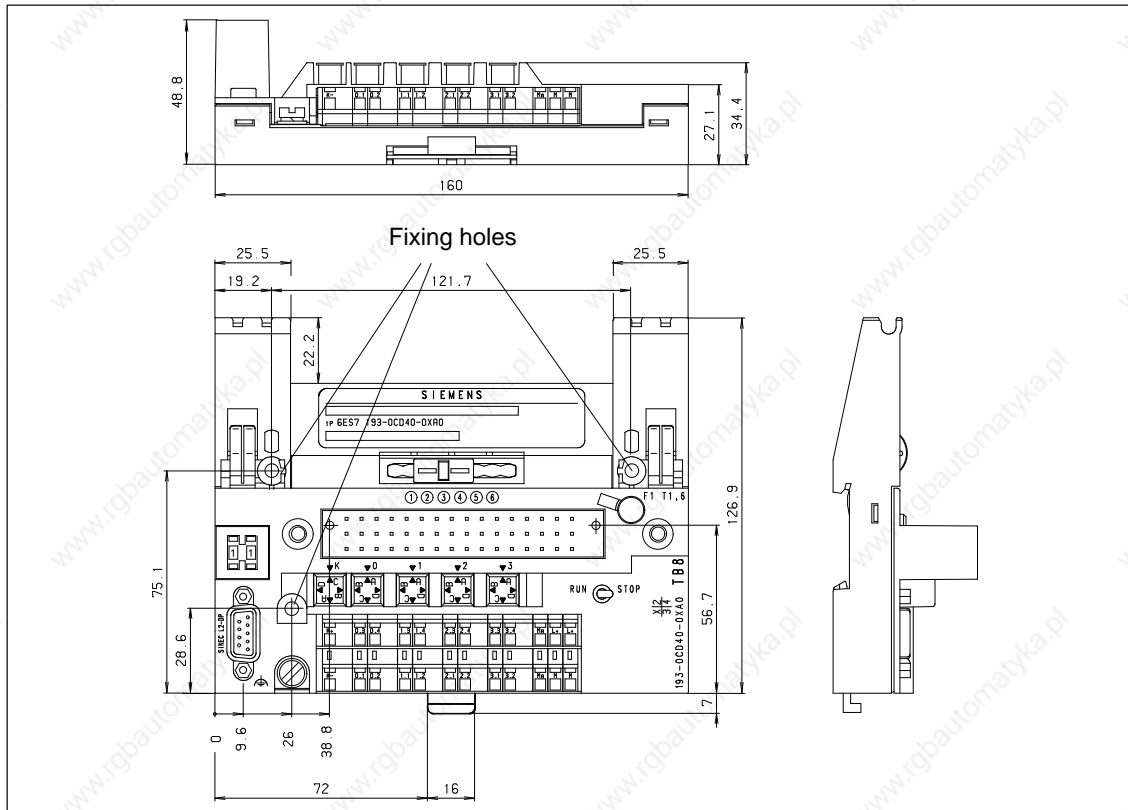

Figure 9-2 Dimension Drawing: TB8 Terminal Block (Spring-Loaded Terminal)

### TB8 Terminal Block (6ES7 193-0CD40-0XA0), continued

**Dimension Drawing TB8 with Bus Conn. (6ES7...)**      Dimension drawing: Side elevation of the TB8 with SINEC L2 bus connector (6ES7 ...)

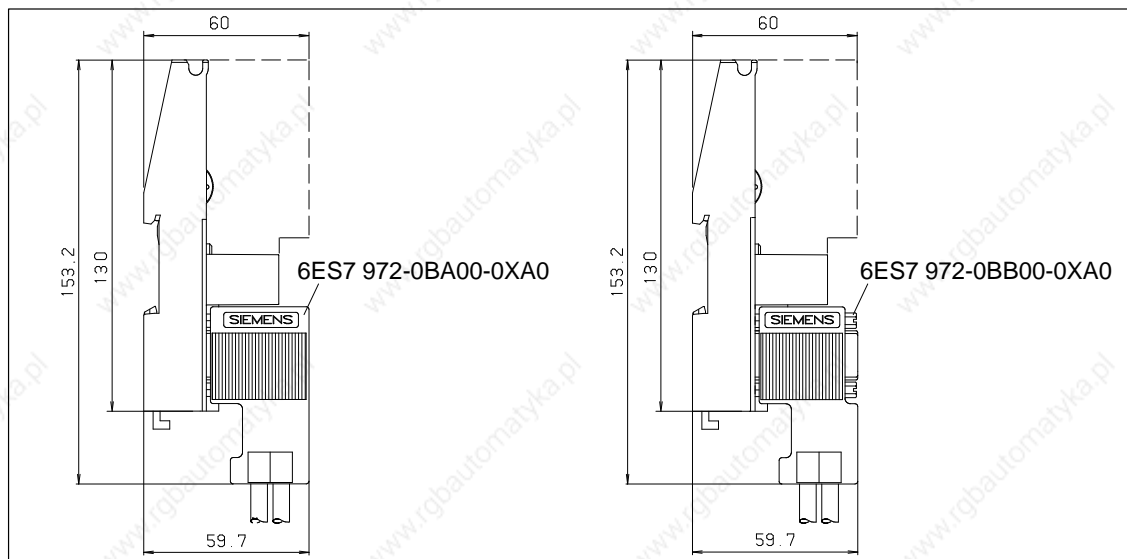

Figure 9-3 Dimension Drawing: Side Elevation of the Terminal Block TB8 with SINEC L2 Bus Connector (6ES7 972-0BA00-0XA0 and 6ES7 972-0BB00-0XA0)

**Dimension Drawing TB8 with Bus Conn. (6ES5...)**      Dimension drawing: Side elevation of the TB8 with SINEC L2 bus connector (6ES5...)

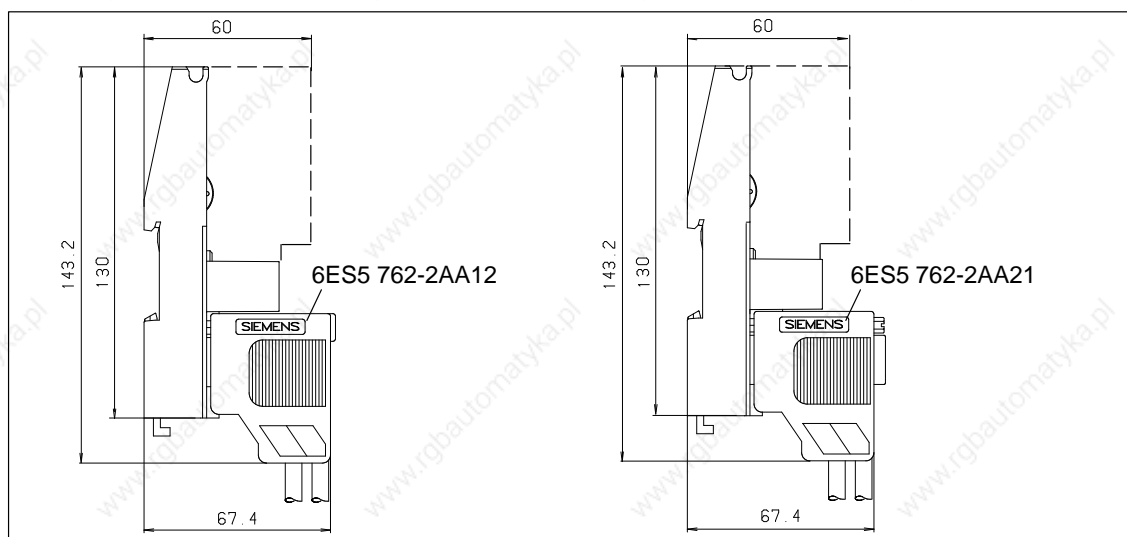

Figure 9-4 Dimension Drawing: Side Elevation of the Terminal Block TB8 with SINEC L2 Bus Connector (6ES5 762-2AA12 and 6ES5 762-2AA21)



## Electronics Block ET 200B-4/8AI (6ES7 134-0KH00-0XB0), continued

### Possible Connections

You can connect the following to the ET 200B-4/8AI electronics block:

- Up to 8 thermocouples with compensating box
- Up to 4 resistance thermometers in 2-wire or 4-wire connection
- Up to 8 voltage sensors (2-wire connection)

Simultaneous connection of different sensors is possible.

### Channel Group

A channel group consists of two channels parameterized with COM ET 200 and the coding plug.

The parameters of a channel group apply generally to all channels of this group (for example input voltage, diagnostics enable, measuring method, etc.)

### Measuring Methods

You have the choice of two methods of measuring analog signals from thermocouples, resistance thermometers and voltage sensors:

- Floating-ground measurement
- Ground-referenced measurement

### Floating-Ground Measurement

In the case of floating-ground measurement (differential measurement), each signal line has its own signal reference conductor.

Differential measurement is required in the following cases:

- If the sensors are connected to different potentials and
- If the different signal sources are physically apart.

---

### Note

The maximum permissible common mode voltage ( $V_{CM}$ ) of the differential inputs to analog ground ( $M_A$ ) is  $\pm 1V$ .

The maximum permissible voltage difference between  $M_A$  and PE must not exceed 75 V DC/60 V AC.

Avoid ground loops!

---

### Ground-Referenced Measurement

In the case of ground-referenced measurement, all signal reference conductors in the TB8 are connected to a common reference point (analog ground  $M_A$ ).

To avoid ground loops, galvanically isolated and ungrounded signal sources (thermocouples, Pt 100, voltage sources) are required.

---

#### Note

Connect  $M_A$  to PE () to enhance noise immunity in the case of ground-referenced measurement.

---

### On the Following Pages

The following pages contain a connection example for every connection possibility and measuring principle. Please note the following rules.

#### Rules

Please note the following rules when connecting measured-value sensors to the ET 200B-4/8AI:

- The permissible potential difference at the differential input ( $x.1 \leftrightarrow x.2$  or  $x.3 \leftrightarrow x.4$ ,  $x = 0$  to  $3$ ) must not exceed  $\pm 1$  V.
- The maximum permissible common mode voltage ( $V_{CM}$ ) between the differential inputs ( $x.1 \leftrightarrow x.2$ ,  $x.3 \leftrightarrow x.4$ ,  $x = 0$  to  $3$ ) and analog ground  $M_A$  is  $\pm 1$  V.
- The maximum permissible isolation voltage between analog ground ( $M_A$ ) and PE () or between the reference potential of the supply voltage (M) is 75 V DC/60 V AC.
- You must short-circuit the connection terminals of unused voltage inputs and connect them to  $M_A$ .

If the coding plug is in the C position, the connection to  $M_A$  is not required (already jumpered internally).

- If you connect only one voltage sensor (2-wire connection) to one channel, you must also short-circuit the remaining free differential input of the channel group and connect it to  $M_A$ .

If the coding plug is in the C position, the connection to  $M_A$  is not required (already jumpered internally).

- If you connect a compensating box, you must short-circuit terminals “K+” and “K-”. For this purpose, set the coding plug to the “C” position.
- 

#### Note

Please note the explanation of shielding of analog lines in Sections 3.1 and 3.5.

---

## Electronics Block ET 200B-4/8AI (6ES7 134-0KH00-0XB0), continued

### Connecting Thermocouples with Compensating Boxes

The ET 200B-4/8AI does not have an internal compensating box. The influence of temperature on the reference junction can be countered with a compensating box.

Please note the following rules when connecting a compensating box:

- The compensating box must be connected to terminals K+ and K-.
- The compensating box must have a floating power supply. The power supply unit of the compensating box must have a grounded shielding winding.
- In the case of external compensation with one compensating box per channel, the same thermocouple type must be used for each channel group.
- External compensation where the compensating box is connected to the COMP connections of the module can only be implemented for one thermocouple type. This means you must use the same type for all channels working with this compensating box.

Figures 9-6 and 9-7 show both methods of connecting thermocouples. Up to 8 thermocouples can be connected.

### Valid Compensating Boxes

We recommend the following compensating boxes for connection to the ET 200B-4/8AI:

- Compensating box type U with current stabilizer.
- Reference junction with built-in power supply unit.

The order numbers of the compensating boxes and the associated components can be found in the tables below.

Table 9-3 Compensating Box Type U with Current Stabilizer.

Accessories	Weight	Order Number
<b>Type U compensating box</b> Reference temp. 20 °C (68 °F)→ 0 mV 0 °C (32 °F)→ 0 mV	0.22 kg (7.7 oz.) 0.22 kg (7.7 oz.)	C70153-A502-A1 C70153-A502-A5
<b>Insert for type U compensating box</b> (as spare part and for installation in distribution boxes or similar) Reference temp. 20 °C (68 °F)→ 0 mV 0 °C (32 °F)→ 0 mV	0.09 kg (3.15 oz.) 0.09 kg (3.15 oz.)	C70153-A502-B7 C70153-A502-B9
<b>Current stabilizer</b> for feeding a compensating box for thermocouple Fe/Cu Ni, Ni Cr/Ni Reference temp. 20 °C (68 °F)→ 0 mV 0 °C (32 °F)→ 0 mV	0.25 kg (8.75 oz.) 0.25 kg (8.75 oz.)	M55232-A1 M55232-A2

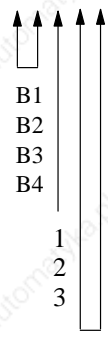

Table 9-4 Reference Junction with Built-In Power Supply Unit

Accessories		Order Number
<b>Reference junction</b> with built-in power supply unit, for installation on a mounting rail		M72166-□□□□
Auxiliary power	220 V AC 110 V AC 24 V AC 24 V DC	 B1 B2 B3 B4
Connection of thermocouple	Fe-CuNi type L Fe/Cu Ni type J Ni Cr/Ni type K	1 2 3
Reference temperature	0 °C (32 °F) 20 °C (68 °F)	00 20

## Electronics Block ET 200B-4/8AI (6ES7 134-0KH00-0XB0), continued

### Floating-Ground Measurement

Connection of thermocouples with a compensating box (floating-ground measurement) is shown below:

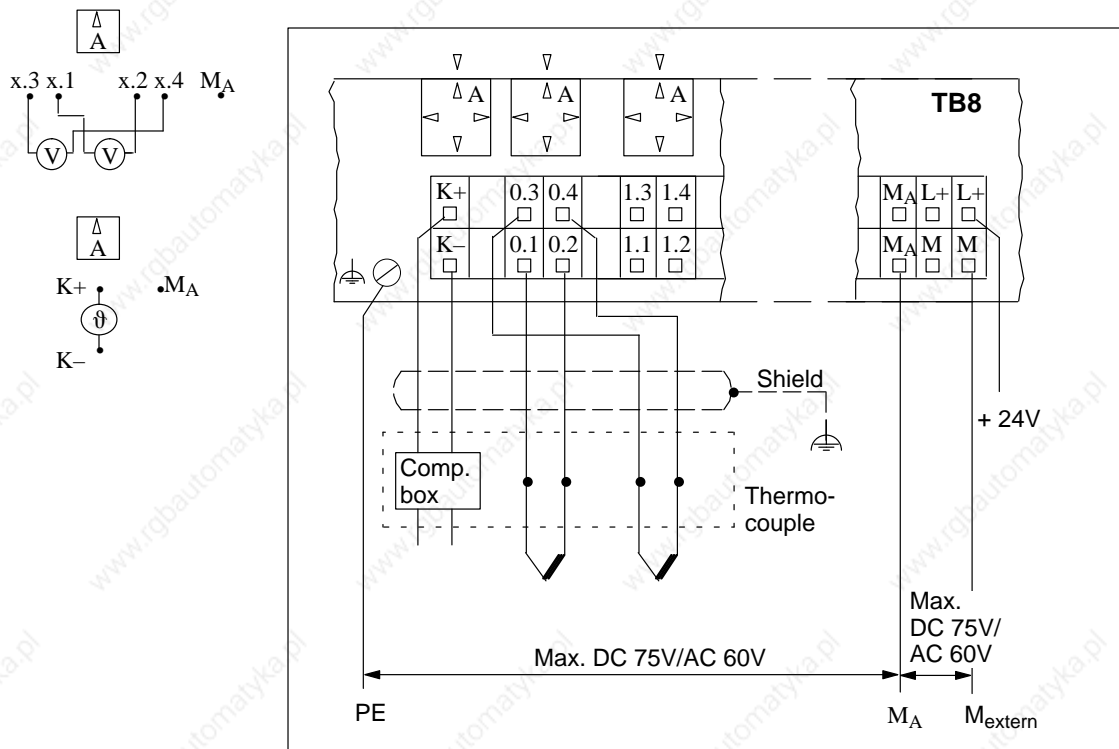

Figure 9-6 Connection of Thermocouples with a Compensating Box (Floating-Ground Measurement)

### Note

The maximum permissible common mode voltage ( $V_{CM} \leq \pm 1V$ ) must not be exceeded at any of the

**Ground-Referenced Measurement**

The connection of thermocouples with a compensating box (ground-referenced measurement) is shown below:

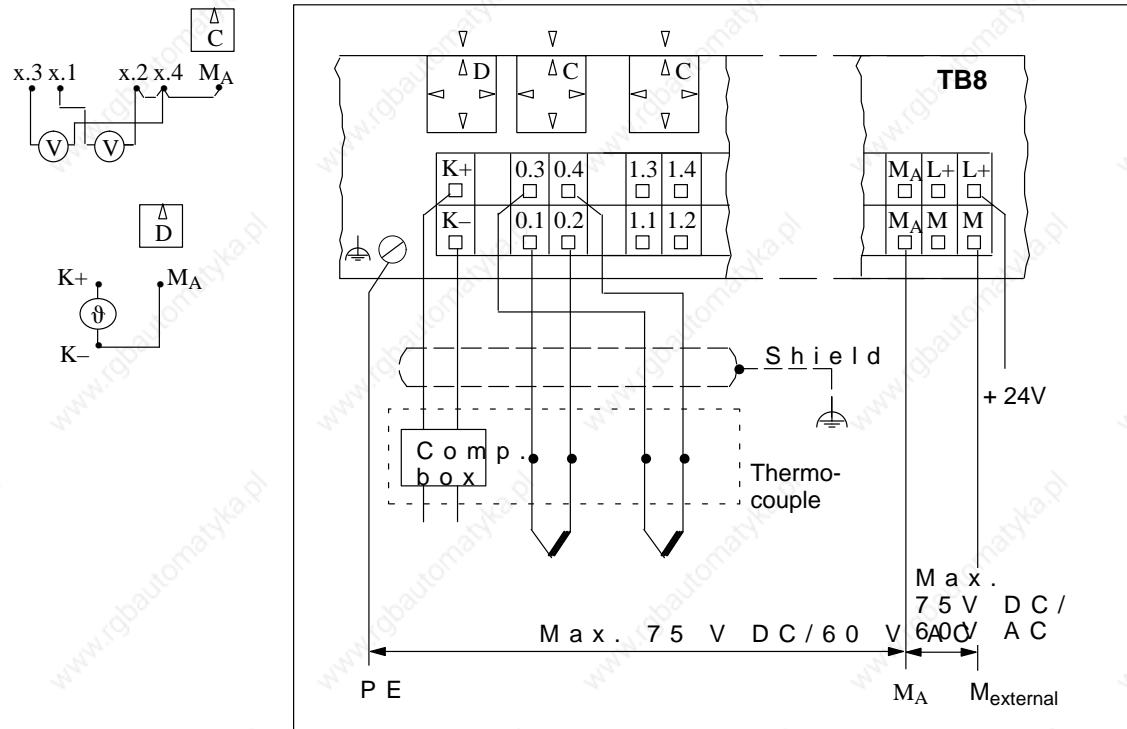

Figure 9-7 Connection of Thermocouples with a Compensating Box (Ground-Referenced Measurement)

## Electronics Block ET 200B-4/8AI (6ES7 134-0KH00-0XB0), continued

### Connection of Resistance Thermometers (2-Wire Connection)

The resistance of the resistance thermometer (Pt 100) is measured via a 2-wire connection.

A constant current is fed to the resistance thermometer via terminals x.1 and x.2. Voltage drops on the measuring lines can corrupt the result of the measurement. This type of measurement is appropriate where the measuring lines are short and thick or where accuracy requirements are not stringent.

Figures 9-8 and 9-9 show both methods of connecting resistance thermometers with 2-wire connections. Up to four Pt 100s can be connected.

### Floating-Ground Measurement

The connection of resistance thermometers (Pt 100) with 2-wire connections (floating-ground measurement) is shown below:

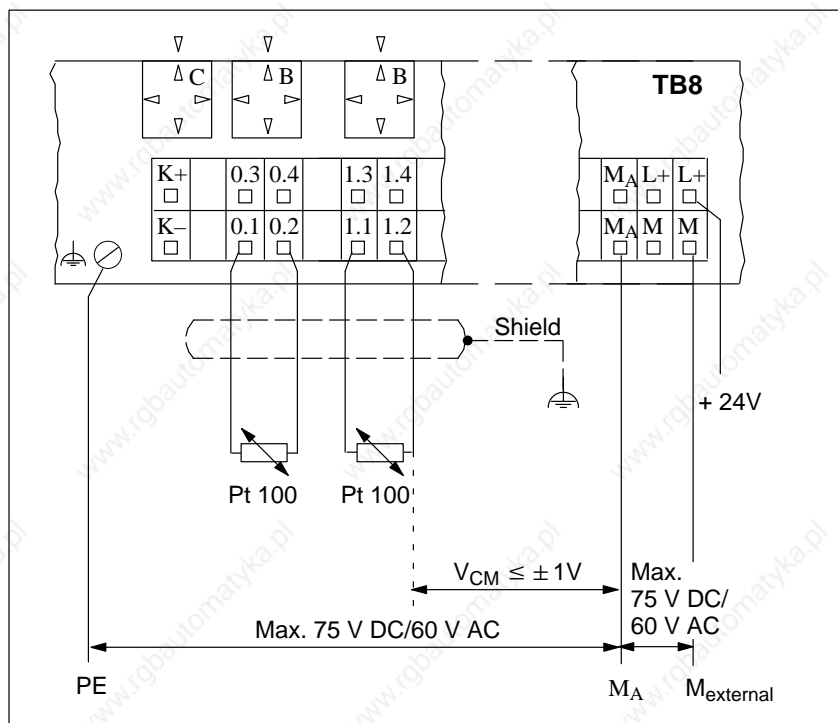
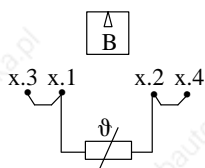
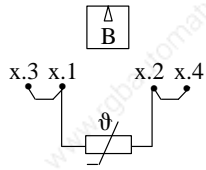

Figure 9-8 Connection of Resistance Thermometers (Pt 100) with 2-Wire Connections (Floating-Ground Measurement)

### Note

The maximum permissible common mode voltage ( $V_{CM} \leq \pm 1V$ ) must not be exceeded at any of the differential inputs with reference to  $M_A$ .

**Ground-Referenced Measurement**



In the case of ground-referenced measurement, you must connect terminal x.4 externally with analog ground ( $M_A$ ).

The connection of resistance thermometers (Pt 100) with 2-wire connections (ground-referenced measurement) is shown below:

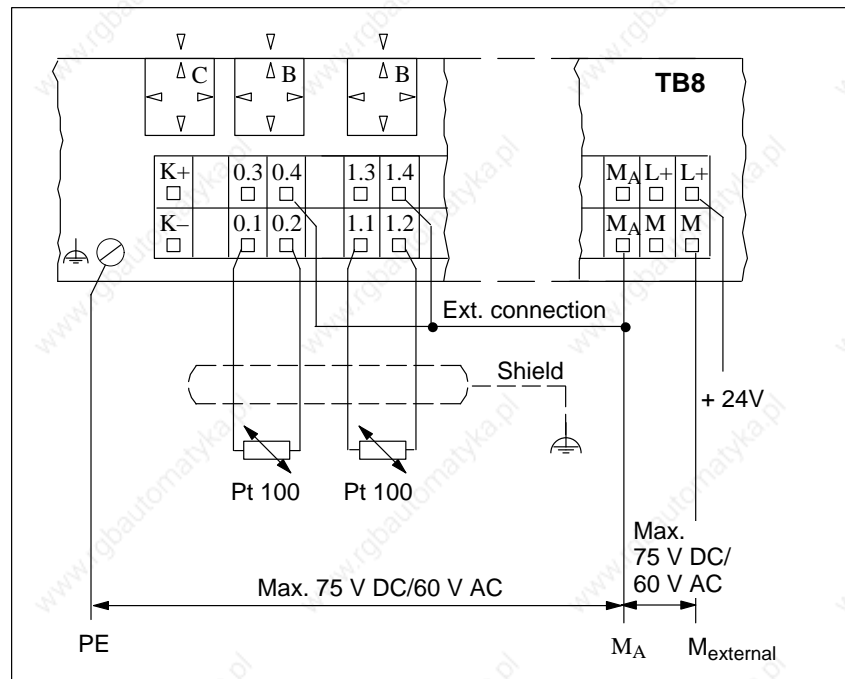

Figure 9-9 Connection of Resistance Thermometers (Pt 100) with 2-Wire Connections (Ground-Referenced Measurement)

## Electronics Block ET 200B-4/8AI (6ES7 134-0KH00-0XB0), continued

### Connection of Resistance Thermometers (4-Wire Connection)

The resistance of the resistance thermometer (Pt 100) is measured via a 4-wire connection.

A constant current  $I_C$  is fed to the resistance thermometer via terminals x.1 and x.2. The voltage generated at the resistance thermometer is measured via x.3/x.4. This means that voltage drops on the “constant current lines” do not corrupt the result of the measurement. The measurement inputs have a high resistance so that only a negligible voltage drop occurs on the measuring lines.

Figures 9-10 and 9-11 show both methods of connecting resistance thermometers with 4-wire connections.

### Floating-Ground Measurement

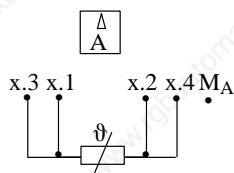

The connection of resistance thermometers (Pt 100) with 4-wire connections (floating-ground measurement) is shown below:

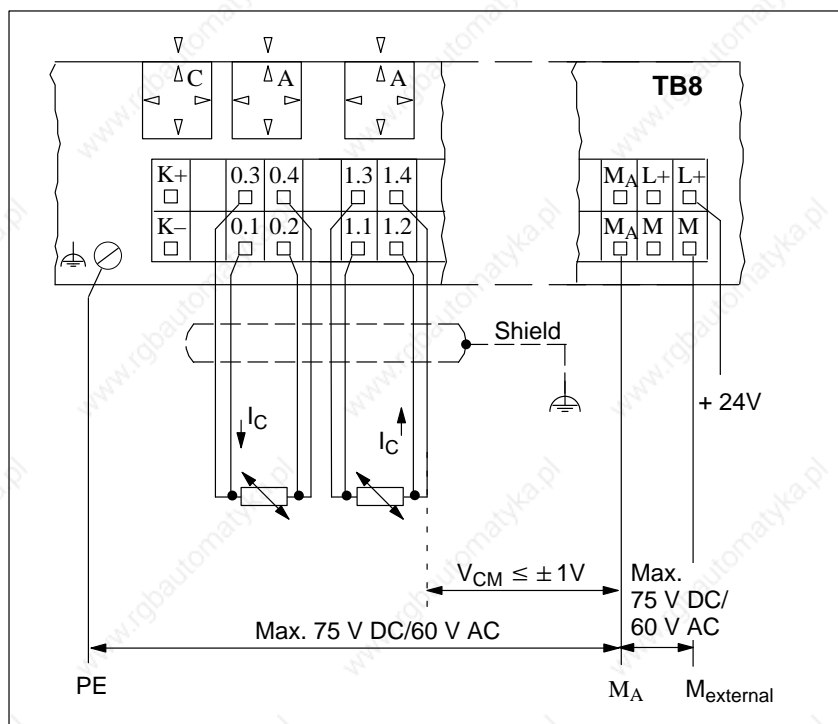

Figure 9-10 Connection of Resistance Thermometers (Pt 100) with 4-Wire Connections (Floating-Ground Measurement)

### Note

The maximum permissible common mode voltage ( $V_{CM} \leq \pm 1V$ ) must not be exceeded at any of the differential inputs with reference to  $M_A$ .

**Ground-Referenced Measurement**

The connection of resistance thermometers (Pt 100) with 4-wire connections (ground-referenced measurement) is shown below:

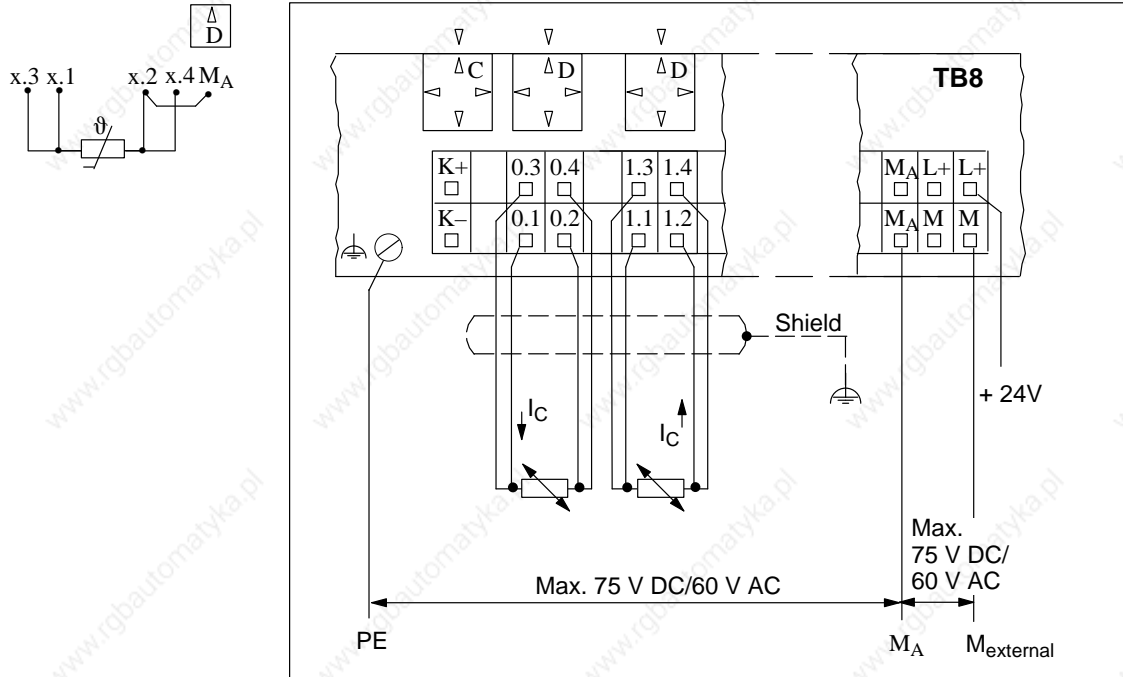

Figure 9-11 Connection of Resistance Thermometers (Pt 100) with 4-Wire Connections (Ground-Referenced Measurement)

## Electronics Block ET 200B-4/8AI (6ES7 134-0KH00-0XB0), continued

### Connecting Voltage Sensors

Free channels can be used for connecting voltage sensors ( $\pm 80 \text{ mV}$ ,  $\pm 250 \text{ mV}$ ,  $\pm 500 \text{ mV}$ ,  $\pm 1000 \text{ mV}$ ).

Two voltage sensors per channel group can be connected.

Figures 9-12 and 9-13 show both methods of connecting voltage sensors.

### Floating-Ground Measurement

Two-wire connection of voltage sensors (floating-ground measurement) is shown below:

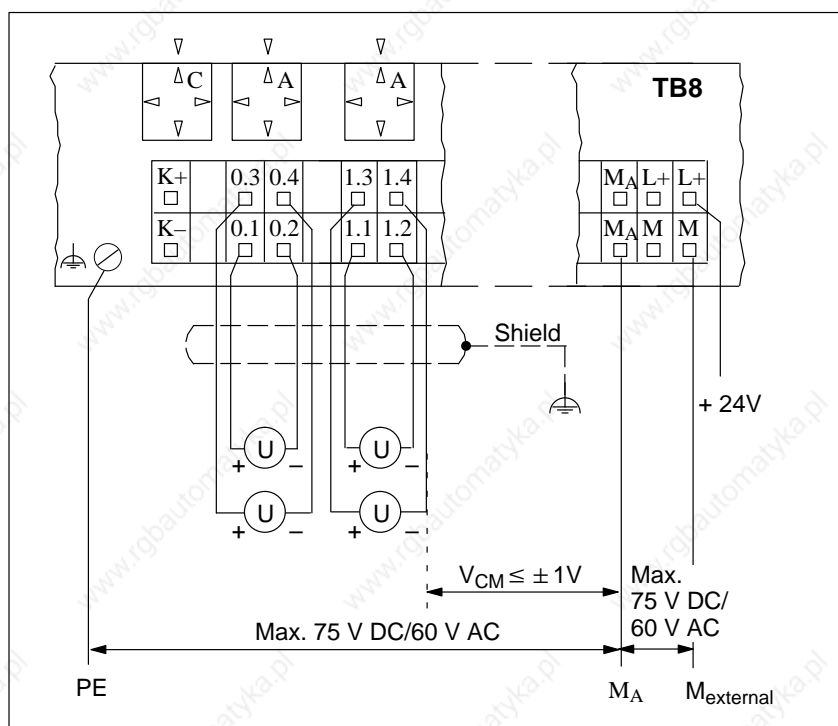
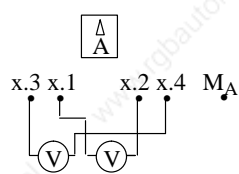

Figure 9-12 Two-Wire Connection of Voltage Sensors to 6ES7 134-0KH00-0XB0 (Floating-Ground Measurement)

### Note

The maximum permissible common mode voltage ( $V_{CM} \leq \pm 1\text{V}$ ) must not be exceeded at any of the differential inputs with reference to  $M_A$ .



**Ground-Referenced Measurement**

Two-wire connection of voltage sensors (ground-referenced measurement) is shown below:

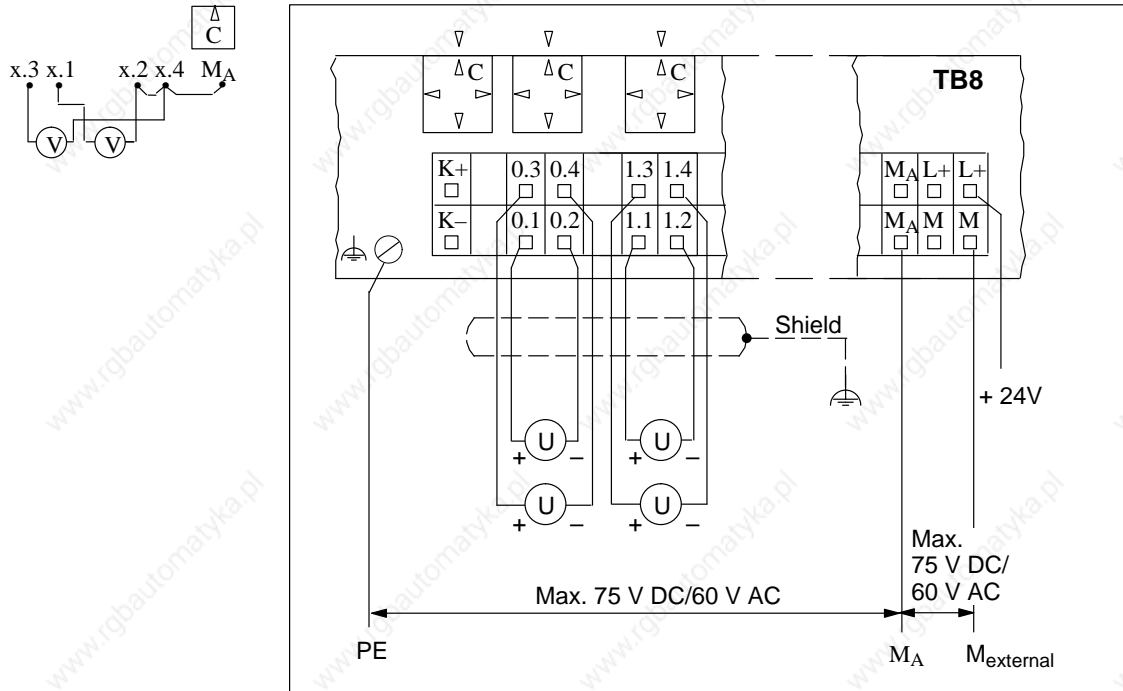

Figure 9-13 Two-Wire Connection of Voltage Sensors to 6ES7 134-0KH00-0XB0 (Ground-Referenced Measurement)

## Electronics Block ET 200B-4/8AI (6ES7 134-0KH00-0XB0), continued

**Parameterization** You define the functional principle of the ET 200B-4/8AI with COM ET 200 parameterization software.

Table 9-5 shows all the parameters for the ET 200B-4/8AI:

Table 9-5 Parameters for ET 200B-4/8AI

Byte <sup>1</sup>	Parameter	Explanation	Value Range
3 (Bit 0)	Diagnostics enable for channel group 0 (channels 0,1) (terminals 0.1/0.2, 0.3/0.4)	Diagnostics messages enabled separately for each channel	<input type="checkbox"/> Disable <input type="checkbox"/> Enable
3 (Bit 1)	Diagnostics enable for channel group 1 (kanal 2, 3) (terminals 1.1/1.2, 1.3/1.4)		
3 (Bit 2)	Diagnostics enable for channel group 2 (channels 4, 5) (terminals 2.1/2.2, 2.3/2.4)		
3 (Bit 3)	Diagnostics enable for channel group 3 (channels 6, 7) (terminals 3.1/3.2, 3.3/3.4)		
4 (Bit 0)	Wire break monitoring enable for channel group 0 (channels 0, 1) (terminals 0.1/0.2, 0.3/0.4)	Wire break monitoring enabled separately for each channel	<input type="checkbox"/> Disable <input type="checkbox"/> Enable
4 (Bit 1)	Wire break monitoring enable for channel group 1 (channels 2, 3) (terminals 1.1/1.2, 1.3/1.4)		
4 (Bit 2)	Wire break monitoring enable for channel group 1 (channels 4, 5) (terminals 2.1/2.2, 2.3/2.4)		
4 (Bit 3)	Wire break monitoring enable for channel group 1 (channels 6, 7) (terminals 3.1/3.2, 3.3/3.4)		
6	Integration time	Specifying the optimum integration time for the A/D converter helps suppress noise voltages	<input type="checkbox"/> 20 ms <input type="checkbox"/> 16,7 ms
7	Measurement method and range for channel group 0 (channels 0, 1) (terminals 0.1/0.2, 0.3/0.4)	You can set the measurement method and range separately for each channel group	<input type="checkbox"/> ± 1 V <input type="checkbox"/> ± 0,5 V <input type="checkbox"/> ± 0,25 V <input type="checkbox"/> ± 80 mV
8	Measurement method and range for channel group 1 (channels 2, 3) (terminals 1.1/1.2, 1.3/1.4)	For voltage measurement:	

Table 9-5 Parameters for ET 200B-4/8AI

Byte <sup>1</sup>	Parameter	Explanation	Value Range
9	Measurement method and range for channel group 2 (channels 4, 5) (terminals 2.1/2.2, 2.3/2.4)	For resistance thermometer with linearization:	Pt 100 standard range
10	Measurement method and range for channel group 3 (channels 6, 7) (terminals 3.1/3.2, 3.3/3.4)	For thermocouple with external reference junction:	Type J with linearization Type K with linearization Type L with linearization
23	Representation of measured values		Two's complement Amount with sign

■ : Default setting in parameterization frame

<sup>1</sup> Byte address in parameterization frame of slave

### Where to Find a Description

Parameterization of the ET 200B-4/8 with COM ET 200 V4.x is described in detail in Section

COM ET 200 WINDOWS also provides extensive support for parameterizing the ET 200B-4/8AI with COM ET 200 WINDOWS through its integrated help system.

Please refer to the *ET 200 Distributed I/O System* manual (Order No. 6ES5 998-3ES12) for further information about how to use COM ET 200 WINDOWS.

## Electronics Block ET 200B-4/8AI (6ES7 134-0KH00-0XB0), continued

### Analog Value Representation

Analog values can be represented in two data formats with the ET 200B-4/8AI:

- 12-bit two's complement representation (range: -2048 to +2047 units)
- 11-bit amount and 1-bit sign (range: -2048 to +2047 units)

Table 9-6 shows the analog value representation of the ET 200B-4/8AI:

Table 9-6 Representing an Analog Input Value as a Bit Pattern (6ES7 134-0KH00-0XB0)

	High Byte								Low Byte							
Bit number	15	14	13	12	11	10	9	8	7	6	5	4	3	2	1	0
Analog value representation	SI	$2^{11}$	$2^{10}$	$2^9$	$2^8$	$2^7$	$2^6$	$2^5$	$2^4$	$2^3$	$2^2$	$2^1$	$2^0$	X	F	OV

Bits 0 to 2 and bit 15 have no significance for the amount of the measured value. See Table 9-7 for a detailed description of these bits.

### Supplementary Bits

Bits 0 to 2 and bit 15 have the following meaning in the bit pattern of the analog input value:

Table 9-7 Description of the Bits (6ES7 134-0KH00-0XB0)

Bit	Meaning	Signal Status	Meaning of the Signal Status
OV	Overflow bit	1	Overrange <sup>1</sup>
F	Fault bit	1	Wire break; the measured value read in is not valid
SI	Sign	0	“+” sign
		1	“-” sign
X	Irrelevant	–	–

<sup>1</sup> In the event of overflow at one measuring point, the overflow bits of the other channels remain unaffected; this means the values of the other channels are correct and can be evaluated.

### Note

When the ET 200B-4/8AI signals a wire break (fault bit F = 1), the overflow bit OV is also set.

**Measured Value Table**

Tables 9-8 to 9-10 show the assignments of analog to digitized measured values for the measuring ranges:  $\pm 80$  mV,  $\pm 250$  mV,  $\pm 500$  mV and  $\pm 1000$  mV.

Table 9-8 Representation of Digitized Measured Values of the ET 200B-4/8AI (6ES7 134-0KH00-0XB0; Measuring Ranges:  $\pm 80$  mV,  $\pm 250$  mV,  $\pm 500$  mV and  $\pm 1000$  mV; **Two's Complement**)

Units	Measured Value in mV				Digitized Measured Value															X	F	OV	Range
	$\pm 80$ mV	$\pm 250$ mV	$\pm 500$ mV	$\pm 1000$ mV	15	14	13	12	11	10	9	8	7	6	5	4	3	2	1				
> 2409	94.10	294.07	588.13	1176.26	0	1	0	0	1	0	1	1	0	1	0	0	1	0	0	1	Over-flow		
2408	94.06	293.95	587.89	1175.78	0	1	0	0	1	0	1	1	0	1	0	0	0	0	0	0	Over-range		
:	:	:	:	:	:																		
2049	80.04	250.12	500.24	1000.48	0	1	0	0	0	0	0	0	0	0	0	0	1	0	0	0			
2048	80.00	250.0	500.0	1000.0	0	1	0	0	0	0	0	0	0	0	0	0	0	0	0	Nominal range			
1024	40.00	125.00	250.00	500.00	0	0	1	0	0	0	0	0	0	0	0	0	0	0	0				
1	0.039	0.12	0.24	0.48	0	0	0	0	0	0	0	0	0	0	0	1	0	0	0				
0	0.00	0.00	0.00	0.00	0	0	0	0	0	0	0	0	0	0	0	0	0	0	0				
-1	-0.039	-0.12	-0.24	-0.48	1	1	1	1	1	1	1	1	1	1	1	1	0	0	0				
-1024	-40.00	-125.00	-250.00	-500.00	1	1	1	0	0	0	0	0	0	0	0	0	0	0	0				
-2048	-80.00	-250.0	-500.0	-1000.0	1	1	0	0	0	0	0	0	0	0	0	0	0	0	0				
-2049	-80.04	-250.12	-500.24	-1000.48	1	0	1	1	1	1	1	1	1	1	1	1	0	0	0	Over-range			
:	:	:	:	:	:																		
-2408	-94.06	-293.95	587.89	-1175.78	1	0	1	1	0	1	0	0	1	1	0	0	0	0	0	0			
< -2409	-94.10	-294.07	-588.13	-1176.26	1	0	1	1	0	1	0	0	1	0	1	1	1	0	0	1	Over-flow		

**Electronics Block ET 200B-4/8AI (6ES7 134-0KH00-0XB0), continued**

Table 9-9 Representation of Digitized Measured Values of the ET 200B-4/8AI (6ES7 134-0KH00-0XB0; Measuring Ranges:  $\pm 80$  mV,  $\pm 250$  mV,  $\pm 500$  mV and  $\pm 1000$  mV; **Amount and Sign**)

Units	Measured Value in mV				SI	Digitized Measured Value										X	F	OV	Range												
	$\pm 80$ mV	$\pm 250$ mV	$\pm 500$ mV	$\pm 1000$ mV		15	14	13	12	11	10	9	8	7	6					5	4	3	2	1	0						
> 2409	94.10	294.07	588.13	1176.26	0	1	0	0	1	0	1	1	0	1	0	0	1	0	0	1	0	0	1	0	0	1	0	0	1	Overflow	
2408	94.06	293.95	587.89	1175.78	0	1	0	0	1	0	1	1	0	1	0	0	0	0	0	0	0	0	0	0	0	0	0	0	0	Overflow	
:	:	:	:	:							:																				
2049	80.04	250.12	500.24	1000.48	0	1	0	0	0	0	0	0	0	0	0	0	0	0	0	0	0	0	0	0	0	0	1	0	0	0	
2048	80.00	250.0	500.0	1000.0	0	1	0	0	0	0	0	0	0	0	0	0	0	0	0	0	0	0	0	0	0	0	0	0	0	Nominal range	
1024	40.00	125.00	250.00	500.00	0	0	1	0	0	0	0	0	0	0	0	0	0	0	0	0	0	0	0	0	0	0	0	0	0		
1	0.039	0.12	0.24	0.48	0	0	0	0	0	0	0	0	0	0	0	0	0	0	0	0	0	0	0	0	0	1	0	0	0		
0	0.00	0.00	0.00	0.00	0	0	0	0	0	0	0	0	0	0	0	0	0	0	0	0	0	0	0	0	0	0	0	0	0		
-1	-0.039	-0.12	-0.24	-0.48	1	0	0	0	0	0	0	0	0	0	0	0	0	0	0	0	0	0	0	0	0	1	0	0	0		
-1024	-40.00	-125.00	-250.00	-500.00	1	0	1	0	0	0	0	0	0	0	0	0	0	0	0	0	0	0	0	0	0	0	0	0	0		
-2048	-80.00	-250.0	-500.0	-1000.0	1	1	0	0	0	0	0	0	0	0	0	0	0	0	0	0	0	0	0	0	0	0	0	0	0		
-2049	-80.04	-250.12	-500.24	-1000.48	1	1	0	0	0	0	0	0	0	0	0	0	0	0	0	0	0	0	0	0	0	1	0	0	0	Overflow	
:	:	:	:	:							:																				
-2408	-94.06	-293.95	587.89	-1175.78	1	1	0	0	1	0	1	1	0	1	0	0	0	0	0	0	0	0	0	0	0	0	0	0	0	0	
< -2409	-94.10	-294.07	-588.13	-1176.26	1	1	0	0	1	0	1	1	0	1	0	0	0	1	0	0	1	0	0	1	0	0	1	0	0	1	Overflow

**Note**

Bit 15 of the digitized measured value indicates the sign.

The following applies: SI = 0  $\rightarrow$  positive value; SI = 1  $\rightarrow$  negative value.

**Measured Value Table**

Table 9-10 shows the assignment of analog to digitized measured value for the resistance thermometer (Pt 100):

Table 9-10 Representation of Digitized Measured Values of the ET 200B-4/8AI in the Case of Resistance Thermometers (**Two's Complement**)

Units	Resistance in $\Omega$	Temperature in $^{\circ}\text{C}$	Digitized Measured Value											X	F	OV	Range		
			15	14	13	12	11	10	9	8	7	6	5					4	3
> 1766	> 400	> 883	0	0	1	1	0	1	1	1	0	0	1	1	0	0	0	1	Overflow
1766		883	0	0	1	1	0	1	1	1	0	0	1	1	0	0	0	1	Overrange <sup>1</sup>
:		:							:										
1702		851	0	0	1	1	0	1	0	1	0	0	1	1	0	0	0	1	
1700	390.26	850	0	0	1	1	0	1	0	1	0	0	1	0	0	0	0	0	Nominal range
1400	345.13	700	0	0	1	0	1	0	1	1	1	1	0	0	0	0	0	0	
1000	280.90	500	0	0	0	1	1	1	1	1	0	1	0	0	0	0	0	0	
600	212.02	300	0	0	0	1	0	0	1	0	1	1	0	0	0	0	0	0	
300	157.31	150	0	0	0	0	1	0	0	1	0	1	1	0	0	0	0	0	
200	138.50	100	0	0	0	0	0	1	1	0	0	1	0	0	0	0	0	0	
2	100.39	1	0	0	0	0	0	0	0	0	0	0	0	1	0	0	0	0	
-0	100.00	0	0	0	0	0	0	0	0	0	0	0	0	0	0	0	0	0	
-40	92.16	-20	1	1	1	1	1	1	1	0	1	1	0	0	0	0	0	0	
-80	84.27	-40	1	1	1	1	1	1	0	1	1	0	0	0	0	0	0	0	
-200	60.25	-100	1	1	1	1	1	0	0	1	1	1	0	0	0	0	0	0	
-202		-101	1	1	1	1	1	0	0	1	1	0	1	1	0	0	0	1	Overrange <sup>1</sup>
:		:							:										
-494		-247	1	1	1	1	0	0	0	0	1	0	0	1	0	0	0	1	
< -494		< -247	1	1	1	1	0	0	0	0	1	0	0	1	0	0	0	1	Overflow

<sup>1</sup> In the overrange, any rise in the characteristic curve is retained when the linearized nominal range is exited.

**Electronics Block ET 200B-4/8AI (6ES7 134-0KH00-0XB0), continued**

**Measured Value Table** Tables 9-11 to 9-13 show the assignment of analog to digitized measured values for thermocouples of types J, K and L.

Table 9-11 Representation of Digitized Measured Values of the ET 200B-4/8AI with Linearization: Thermocouple Type K (Nickel-Chromium/Nickel-Aluminum, to IEC 584) (**Two's Complement**)

Units	Thermal e. m. f. in mV <sup>1</sup>	Temperature in °C	Digitized Measured Value										X	F	OV	Range			
			15	14	13	12	11	10	9	8	7	6					5	4	3
> 2359			0	1	0	0	1	0	0	1	1	0	1	1	1	0	0	1	Overflow
1370		1370	0	0	1	0	1	0	1	0	1	1	0	1	0	0	0	1	Overrange <sup>2</sup>
1369	54.773	1369	0	0	1	0	1	0	1	0	1	1	0	0	1	0	0	0	Nominal range
1000	41.269	1000	0	0	0	1	1	1	1	1	0	1	0	0	0	0	0	0	
500	20.640	500	0	0	0	0	1	1	1	1	1	0	1	0	0	0	0	0	
150	6.137	150	0	0	0	0	0	1	0	0	1	0	1	1	0	0	0	0	
100	4.095	100	0	0	0	0	0	0	1	1	0	0	1	0	0	0	0	0	
1	0.039	1	0	0	0	0	0	0	0	0	0	0	0	0	1	0	0	0	
0	0	0	0	0	0	0	0	0	0	0	0	0	0	0	0	0	0	0	
-1	-0.039	-1	1	1	1	1	1	1	1	1	1	1	1	1	1	0	0	0	
-100	-3.553	-100	1	1	1	1	1	1	0	0	1	1	1	0	0	0	0	0	Accuracy ≤ 2 K
-101	-3.584	-101	1	1	1	1	1	1	0	0	1	1	0	1	1	0	0	0	
-150	-4.912	-150	1	1	1	1	1	0	1	1	0	1	0	1	0	0	0	0	
-200	-5.891	-200	1	1	1	1	1	0	0	1	1	1	0	0	0	0	0	0	
-201		-201	1	1	1	1	1	0	0	1	1	0	1	1	1	0	0	1	Overrange <sup>2</sup>
-273			1	1	1	1	0	0	0	0	1	0	0	1	0	0	0	1	Overflow
X		X	X	X	X	X	X	X	X	X	X	X	X	X	X	0	1	0	Wire break

<sup>1</sup> For a reference temperature of 0 °C (32 °F)  
<sup>2</sup> In the overrange, any rise in the characteristic curve is retained when the linearized nominal range is exited.



Table 9-12 Representation of Digitized Measured Values of the ET 200B-4/8AI with Linearization: Thermocouple Type J (Iron/Copper-Nickel (Constantan), to IEC 584) (Two's Complement)

Units	Thermal e. m. f. in mV <sup>1</sup>	Temperature in °C	Digitized Measured Value										X	F	OV	Range			
			15	14	13	12	11	10	9	8	7	6					5	4	3
1485			0	0	1	0	1	1	1	0	0	1	1	0	1	0	0	1	Overflow
1201		1201	0	0	1	0	0	1	0	1	1	0	0	0	1	0	0	1	Overrange <sup>2</sup>
1200	69.536	1200	0	0	1	0	0	1	0	1	1	0	0	0	0	0	0	0	Nominal range
1000	57.942	1000	0	0	0	1	1	1	1	1	0	1	0	0	0	0	0	0	
500	27.388	500	0	0	0	0	1	1	1	1	1	0	1	0	0	0	0	0	
100	5.268	100	0	0	0	0	0	0	1	1	0	0	1	0	0	0	0	0	
1	0.05	1	0	0	0	0	0	0	0	0	0	0	0	0	1	0	0	0	
0	0	0	0	0	0	0	0	0	0	0	0	0	0	0	0	0	0	0	
-1	-0.05	-1	1	1	1	1	1	1	1	1	1	1	1	1	1	0	0	0	
-100	-4.632	-100	1	1	1	1	1	1	0	0	1	1	1	0	0	0	0	0	
-150	-6.499	-150	1	1	1	1	1	0	1	1	0	1	0	1	0	0	0	0	
-199	-7.868	-199	1	1	1	1	1	0	0	1	1	1	0	0	1	0	0	0	
-200	-7.890	-200	1	1	1	1	1	0	0	1	1	1	0	0	0	0	0	0	
-201		-201	1	1	1	1	1	0	0	1	1	0	1	1	1	0	0	1	Overrange <sup>2</sup>
-273			1	1	1	1	0	1	1	1	0	1	1	1	1	0	0	1	Overflow
X		X	X	X	X	X	X	X	X	X	X	X	X	X	X	0	1	0	Wire break

<sup>1</sup> For a reference temperature of 0 °C (32 °F)

<sup>2</sup> In the overrange, any rise in the characteristic curve is retained when the linearized nominal range is exited.

**Electronics Block ET 200B-4/8AI (6ES7 134-0KH00-0XB0), continued**

Table 9-13 Representation of Digitized Measured Values of the ET 200B-4/8AI with Linearization: Thermocouple Type L (Iron/Copper-Nickel (Constantan), to DIN 43710) (Two's Complement)

Units	Thermal e. m. f. in mV <sup>1</sup>	Temperature in °C	Digitized Measured Value										X	F	OV	Range			
			15	14	13	12	11	10	9	8	7	6					5	4	3
1361			0	0	1	0	1	0	1	0	1	0	0	0	1	0	0	1	Overflow
901		901	0	0	0	1	1	1	0	0	0	0	1	0	1	0	0	1	Over-range <sup>2</sup>
900	53.14	900	0	0	0	1	1	1	0	0	0	0	1	0	0	0	0	0	Nominal range
500	27.85	500	0	0	0	0	1	1	1	1	0	1	0	0	0	0	0		
250	13.75	250	0	0	0	0	0	1	1	1	1	0	1	0	0	0	0		
100	+5.37	100	0	0	0	0	0	0	1	1	0	0	1	0	0	0	0		
1	0.05	1	0	0	0	0	0	0	0	0	0	0	0	1	0	0	0		
0	0	0	0	0	0	0	0	0	0	0	0	0	0	0	0	0	0		
-1	-0.05	-1	1	1	1	1	1	1	1	1	1	1	1	1	0	0	0		
-100	-4.75	-100	1	1	1	1	1	0	0	1	1	1	0	0	0	0	0		
-150	-6.60	-150	1	1	1	1	1	0	1	1	0	1	0	1	0	0	0		
-190	-7.86	-190	1	1	1	1	1	0	1	0	0	0	0	1	0	0	0		
-199	-8.12	-199	1	1	1	1	1	0	0	1	1	1	0	0	1	0	0		
-200		-200	1	1	1	1	1	0	0	1	1	1	0	0	0	0	1	Over-range <sup>2</sup>	
-273			1	1	1	1	0	1	1	1	0	1	1	1	1	0	1	Overflow	
X		X	X	X	X	X	X	X	X	X	X	X	X	X	0	1	0	Wire break	

<sup>1</sup> For a reference temperature of 0 °C (32 °F)

<sup>2</sup> In the overrange, any rise in the characteristic curve is retained when the linearized nominal range is exited.

**Schematic Circuit Diagram**

Simplified representation of potential for the ET 200B-4/8AI and TB8:

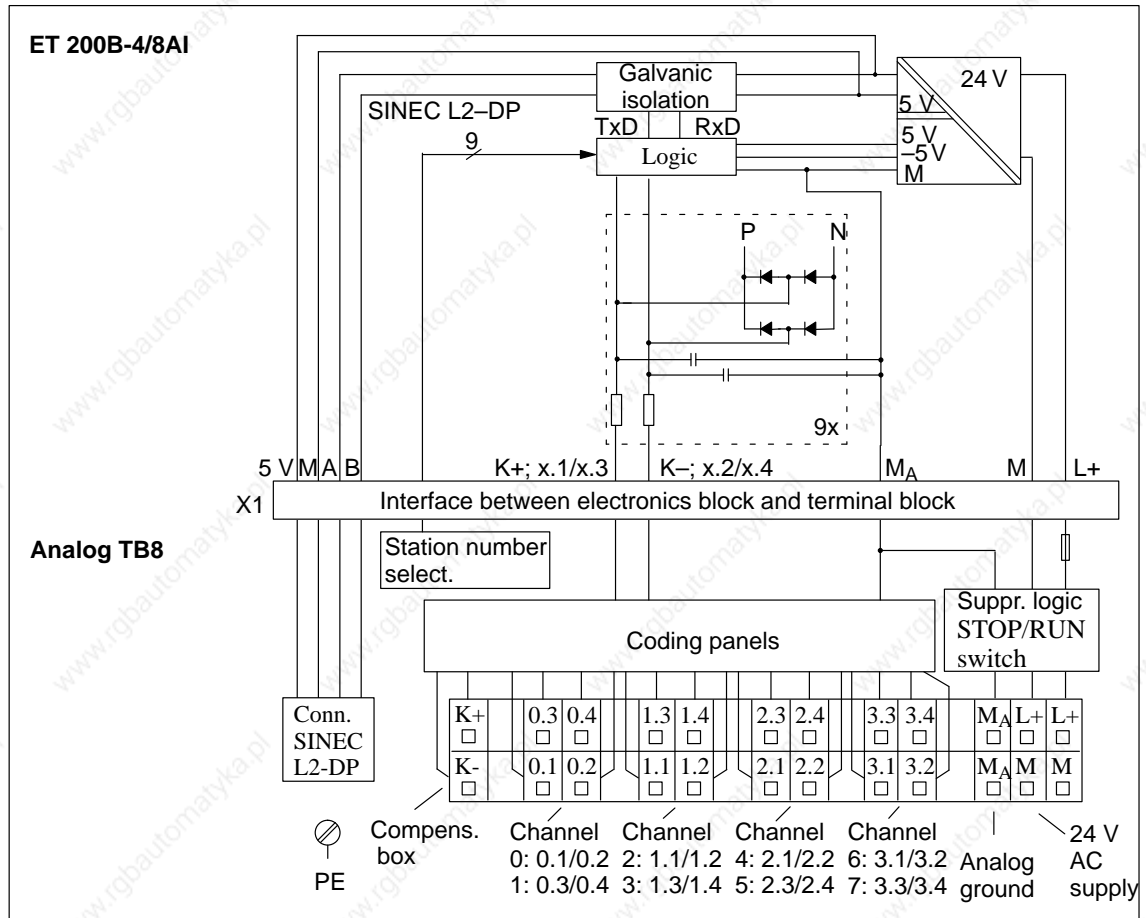

Figure 9-14 Schematic Circuit Diagram: ET 200B-4/8AI (6ES7 134-0KH00-0XB0) and TB8

## Electronics Block ET 200B-4/8AI (6ES7 134-0KH00-0XB0), continued

### Terminal Assignments

The ET 200B-4/8AI is plugged into the TB8.

Table 9-14 contains the terminal assignments of the TB8 for the ET 200B-4/8AI depending on the sensor connected.

Table 9-14 Terminal Assignments of the TB8 for ET 200B-4/8AI (6ES7 134-0KH00-0XB0)

Terminal	Assignment When the Following are Connected		
	Thermocouple	Resistance Thermometer	Voltage Sensor
K+	Compensating box	Unassigned	Unassigned
K-	Compensating box	Unassigned	Unassigned
x.1	Measuring line (+)	Constant current line $I_{C+}$	Measuring line (+)
x.2	Measuring line (-)	Constant current line $I_{C-}$	Measuring line (-)
x.3	Measuring line (+)	Measuring line (+)	Measuring line (+)
x.4	Measuring line (-)	Measuring line (-)	Measuring line (-)
$M_A$	Analog ground ( $M_A$ )		
L+	Voltage supply for internal logic		
M	Voltage supply for internal logic		

x = 0, 1, 2, 3

### Note

You must make additional settings for the input circuits of the TB8 via coding plugs. See Figures 9-12 and 9-13 for the necessary settings of the coding plugs.

Technical specifications		Inputs, continued	
Baud rates	9.6/19.2/93.75/187.5/500/1500 kbps	Characteristic curve linearization for following thermocouples	
Bus protocol	DP Standard	<ul style="list-style-type: none"> <li>Nickel-chromium/nickel-aluminum (type K) To IEC 584</li> <li>Iron/copper-nickel (type J) To IEC 584</li> <li>Iron/copper-nickel (type L) To DIN 43710</li> </ul>	
Galvanic isolation to SINEC L2-DP bus	Yes	Linearization accuracy in nominal range (for types K, J, L)	$\pm 1^{\circ}\text{C}$ (33.8 $^{\circ}\text{F}$ )
Power losses	Typ. 2 W	Method of connecting signal sensors	2-wire connection; 4-wire connection for Pt 100
Weight (EB and TB)	Approx. 550 g (19.25 oz.)	Input resistance	$\geq 10\ \text{M}\Omega$
Dimensions (EB and TB): W x H x D)	160 x 130 x 60 mm (6.24 x 5.07 x 2.34 in.)	Measured value representation	Can be switched between following data formats: 12-bit two's complement, 11-bit amount with sign
Diagnostics functions		Overrange	Approx. 17.5 %
Voltage monitoring	Green "RUN" LED	Measuring method	Integrating
Bus monitoring SINEC L2-DP	Red "BF" LED	Integration/conversion time/resolution (per channel)	
Group diagnostics	Red "DIA" LED, parameterizable	<ul style="list-style-type: none"> <li>Parameterizable Yes</li> <li>Integration time in ms <math>16^{2/3}</math> 20</li> <li>Basic conversion time incl. integration time and offset measuring time in ms 34 44</li> </ul>	
Supply voltage for inputs and internal logic		or additional conversion time for wire break monitoring in ms 10 10	
Supply voltage (L+)		<ul style="list-style-type: none"> <li>Noise suppression for interference frequency f1 in Hz 60 50</li> </ul>	
<ul style="list-style-type: none"> <li>Rated value 24 V DC</li> <li>Permissible range 18.5 to 30.2 V</li> <li>Value for <math>t &lt; 0.5\text{s}</math> 35 V</li> </ul>		Permissible potential difference	
Current consumption from L+		<ul style="list-style-type: none"> <li>Inputs to each other Max. <math>\pm 1\ \text{V}</math></li> <li>Inputs to <math>M_A</math> (<math>V_{CM}</math>) Max. <math>\pm 1\ \text{V}</math></li> <li><math>M_A</math> to PE or M Max. 75 V DC/60 V AC</li> </ul>	
<ul style="list-style-type: none"> <li>Logic 80 mA</li> </ul>			
Inputs			
Number of inputs	8 voltage inputs or 4 inputs for Pt 100 or 8 inputs for thermocouple types K, J, L		
Galvanic isolation to internal electronic circuits	No		
Galvanic isolation to voltage supply of internal electronic logic	Yes		
Measured value ranges			
<ul style="list-style-type: none"> <li>Voltage sensors <math>\pm 80\ \text{mV}</math>, <math>\pm 250\ \text{mV}</math>, <math>\pm 500\ \text{mV}</math>, <math>\pm 1000\ \text{mV}</math></li> <li>Resistance-type sensors 0 to 400 <math>\Omega</math></li> </ul>			
Permissible input voltage for voltage input (destruction limit)	32 V		

**Electronics Block ET 200B-4/8AI (6ES7 134-0KH00-0XB0), continued**

Inputs, continued	Inputs, continued
<p>Fault message in event of</p> <ul style="list-style-type: none"> <li>• Overrange Yes</li> <li>• Wire break of signal sensor lines Yes for Pt 100, <math>\pm 80</math> mV, thermocouple types K, J, L (can be set with COM ET 200)</li> </ul> <p>Noise suppression for <math>f = n \times (f1 \pm 1\%)</math> (f1 = interference frequency)</p> <ul style="list-style-type: none"> <li>• Common mode noise <math>&gt; 70</math> dB (<math>V_{pp} &lt; 3</math> V)</li> <li>• Series-mode noise <math>&gt; 40</math> dB (peak value of interference <math>&lt;</math> rated value of input range)</li> </ul> <p>Crosstalk between the inputs</p> <ul style="list-style-type: none"> <li>• At 50 Hz 50 dB</li> <li>• At 60 Hz 50 dB</li> </ul> <p>Working error limit (over entire temperature range in relation to input range)</p> <ul style="list-style-type: none"> <li>• 80 mV <math>\pm 1\%</math></li> <li>• From 250 to 1000 mV <math>\pm 0.6\%</math></li> <li>• Thermocouples <math>\pm 10</math> K</li> <li>• Resistance <math>\pm 5</math> K</li> </ul>	<p>Basic error limit (working error limit at 25 °C (77 °C) in relation to input range)</p> <ul style="list-style-type: none"> <li>• 80 mV <math>\pm 0.6\%</math></li> <li>• From 250 to 1000 mV <math>\pm 0.4\%</math></li> <li>• Thermocouples <math>\pm 7</math> K</li> <li>• Resistance <math>\pm 3</math> K</li> </ul> <p>Temperature error (in relation to input range) <math>\pm 0.005\%/K</math></p> <p>Linearity error (in relation to input range) <math>\pm 0.05\%</math></p> <p>Repeatability (in steady-state condition at 25°C (77 °F), in relation to input range) <math>\pm 0.05\%</math></p> <p>Cable length</p> <ul style="list-style-type: none"> <li>• Shielded Max. 100 m (328 ft.)</li> </ul>

### 9.1.4 Electronics Block ET 200B-4AI (6ES7 134-0HF00-0XB0)

#### Characteristics

The ET 200B-4AI electronics block has the following features:

- 4 inputs, floating to the supply voltage of the internal logic
- Measuring ranges:  $\pm 1.25$  V,  $\pm 2.5$  V,  $\pm 5$  V,  $\pm 10$  V, 0 to 20 mA, 4 to 20 mA,  $\pm 20$  mA
- Measuring principle: successive approximation
- Supply voltage: 24 V DC
- Connectable sensors
  - Voltage sensors (2-wire connection)
  - Current sensors (2-wire connection)
- Measuring range set using COM ET 200

#### Dimension Drawing

See Figure 9-5 for the precise dimensions.

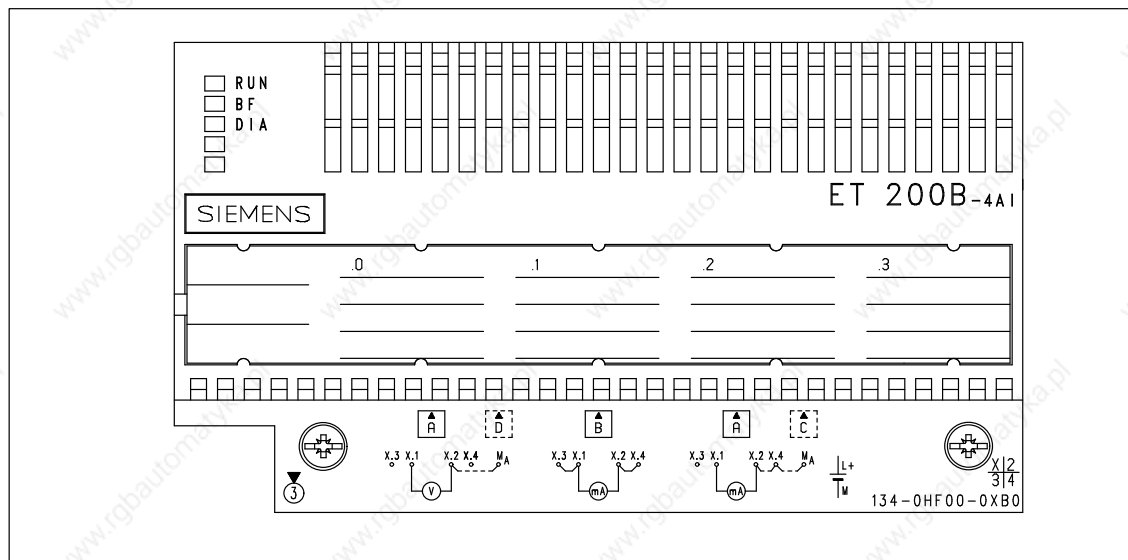

Figure 9-15 Front Elevation: ET 200B-4AI (6ES7 134-0HF00-0XB0)

## Electronics Block ET 200B-4AI (6ES7 134-0HF00-0XB0), continued

### Possible Connections

You can connect the following to the ET 200B-4AI:

- Up to 4 voltage sensors (2-wire connection)
- Up to 4 current sensors (2-wire connection)

Mixed connection of current and voltage sensors is possible.

### Measuring Methods

You have the choice of two methods of measuring analog signals from current/voltage sensors:

- Floating-ground measurement
- Ground-referenced measurement

### Floating-Ground Measurement

In the case of floating-ground measurement (differential measurement), each signal line has its own signal reference conductor.

Differential measurement is required in the following cases:

- If the sensors are connected to different potentials and
- If the different signal sources are physically apart.

---

### Note

The maximum permissible common mode voltage ( $V_{CM}$ ) of the differential inputs to analog ground ( $M_A$ ) is  $\pm 1$  V.

The maximum permissible voltage difference between  $M_A$  and PE must not exceed 75 V DC/60 V AC.

Avoid ground loops!

---

### Ground-Referenced Measurement

In the case of ground-referenced measurement, all signal reference conductors in the TB8 are connected to a common reference point (analog ground  $M_A$ ).

To avoid ground loops, galvanically isolated and ungrounded signal sources (thermocouples, Pt 100, voltage sources) are required.

---

### Note

Connect  $M_A$  to PE() to enhance noise immunity in the case of ground-referenced measurement.

---



**On the Following Pages**

The following pages contain a connection example for every connection possibility and measuring principle. Please note the following rules.

**Rules**

Please note the following rules when connecting measured-value sensors to the ET 200B-4AI:

- The permissible potential difference at the differential input ( $x.1 \leftrightarrow x.2$ ,  $x = 0$  to 3) must not exceed  $\pm 10$  V.
- The maximum permissible common mode voltage ( $V_{CM}$ ) between the differential inputs ( $x.1 \leftrightarrow x.2$ ,  $x = 0$  to 3) and analog ground  $M_A$  is  $\pm 1$  V.
- The maximum permissible isolation voltage between analog ground ( $M_A$ ) and PE () or between the reference potential of the supply voltage (M) is 75 V DC/60 V AC.
- You must short-circuit the connection terminals of unused voltage inputs and connect them to  $M_A$  (coding plug at position "D" for voltage sensors; position "C" implements the connection to  $M_A$  for current sensors).
- You must short-circuit terminals "K+" and "K-". For this purpose, set the coding plug to the "C" position.

---

**Note**

Please note the explanation of shielding of analog lines in Sections 3.1 and 3.5.

---

## Electronics Block ET 200B-4AI (6ES7 134-0HF00-0XB0), continued

### Connecting Voltage Sensors

Voltage sensors for the following measured value ranges can be connected:  
 $\pm 1.25\text{ V}$ ,  $\pm 2.5\text{ V}$ ,  $\pm 5\text{ V}$ ,  $\pm 10\text{ V}$

Figures 9-16 and 9-17 show the two methods of connecting voltage sensors.

### Floating-Ground Measurement

Figure 9-16 shows the 2-wire connection of voltage sensors (floating-ground measurement):

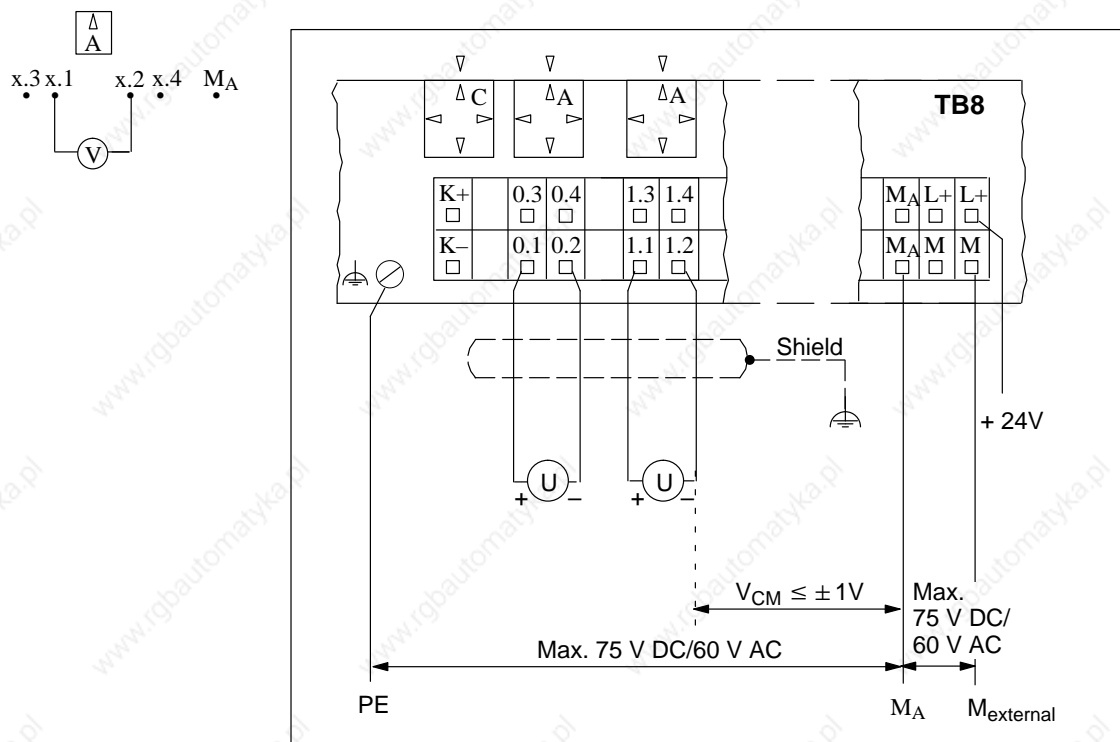

Figure 9-16 Two-Wire Connection of Voltage Sensors to 6ES7 134-0HF00-0XB0 (Floating-Ground Measurement)

### Note

The maximum permissible common mode voltage ( $V_{CM} \leq \pm 1\text{ V}$ ) must not be exceeded at any of the differential inputs with reference to  $M_A$ .

**Ground-Referenced Measurement**

The 2-wire connection of voltage sensors (ground-referenced measurement) is shown below:

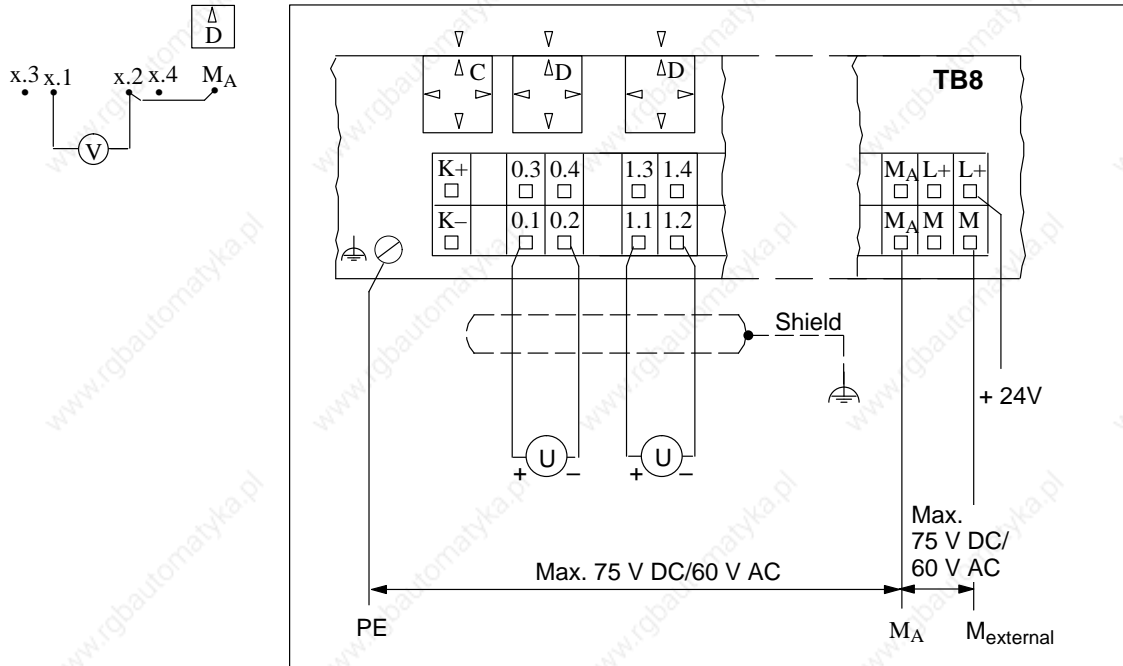

Figure 9-17 Two-Wire Connection of Voltage Sensors 6ES7 134-0HF00-0XB0 (Ground-Referenced Measurement)

## Electronics Block ET 200B-4AI (6ES7 134-0HF00-0XB0), continued

### Connecting Current Sensors

Current sensors for the following measured value ranges can be connected:  
0 to 20 mA, 4 to 20 mA,  $\pm 20$  mA

Figures 9-18 and 9-19 show the two methods of connecting current sensors.

### Floating-Ground Measurement

The 2-wire connection of current sensors (floating-ground measurement) is shown below:

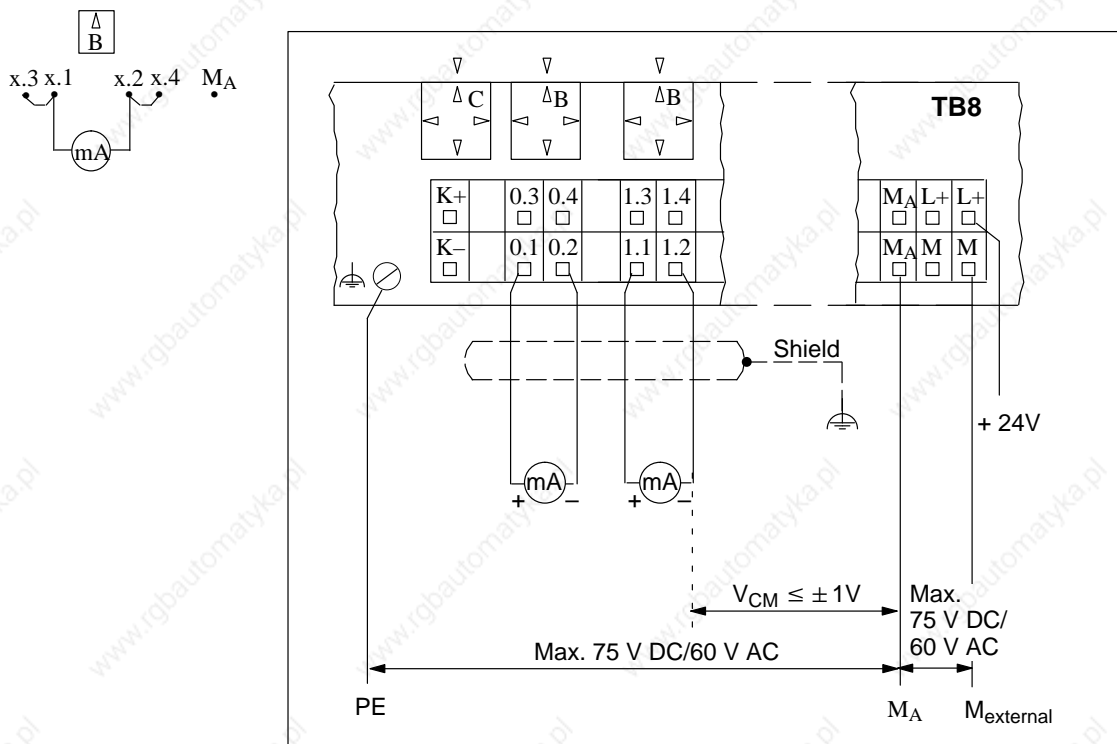

Figure 9-18 Two-Wire Connection of Current Sensors (Floating-Ground Measurement)

### Note

The maximum permissible common mode voltage ( $V_{CM} \leq \pm 1 V$ ) must not be exceeded at any of the differential inputs with reference to  $M_A$ .

**Ground-Referenced Measurement**

The 2-wire connection of current sensors (ground-referenced measurement) is shown below:

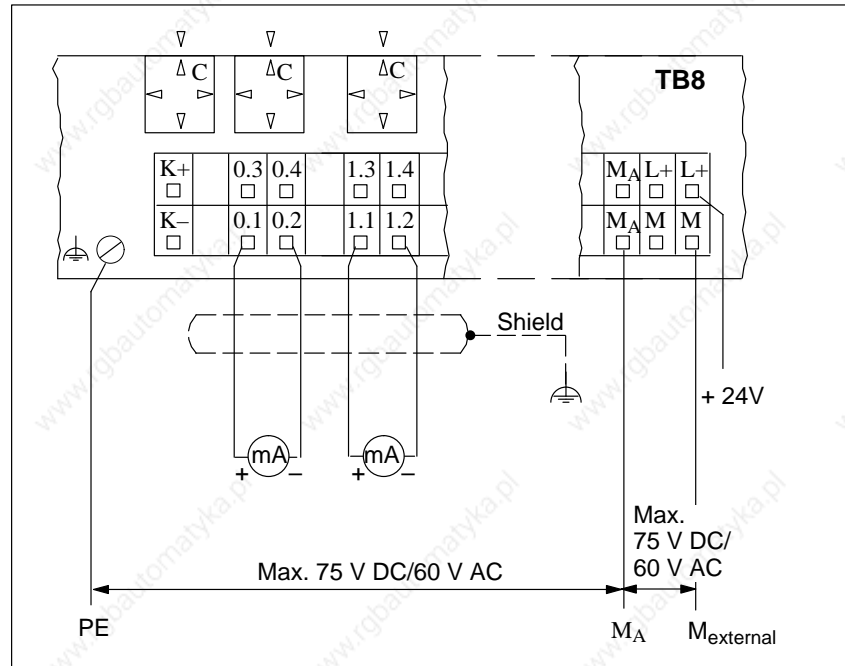
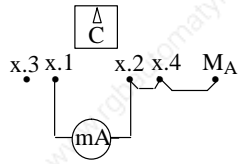

Figure 9-19 Two-Wire Connection of Current Sensors (Ground-Referenced Measurement)

## Electronics Block ET 200B-4AI (6ES7 134-0HF00-0XB0), continued

**Parameterization** You can define the functional principle of the ET 200B-4AI with the COM ET 200 parameterization software.

Table 9-15 shows all the parameters for the ET 200B-4AI:

Table 9-15 Parameter für ET 200B-4AI

Byte <sup>1</sup>	Parameter	Explanation	Value Range
3 (Bit 0)	Diagnostic enable for channel 0 (terminals 0.1/0.2)	Diagnostics messages enabled separately for each channel	<div style="background-color: #cccccc; display: inline-block; width: 1em; height: 1em; vertical-align: middle;"></div> Disable Enable
3 (Bit 1)	Diagnostic enable for channel 1 (terminals 1.1/1.2)		
3 (Bit 2)	Diagnostic enable for channel 2 (terminals 2.1/2.2)		
3 (Bit 3)	Diagnostic enable for channel 3 (terminals 3.1/3.2)		
7	Measurement method and range for channel 0 (terminals 0.1/0.2)	You can set the measurement method and range separately for each channel.  For voltage measurement:  For current measurement:	<div style="background-color: #cccccc; display: inline-block; width: 1em; height: 1em; vertical-align: middle;"></div> ± 10 V ± 5 V ± 2,5 V ± 1,25 mV  ± 20 mA 0 to 20 mA 4 to 20 mA
8	Measurement method and range for channel 1 (terminals 1.1/1.2)		
9	Measurement method and range for channel 2 (terminals 2.1/2.2)		
10	Measurement method and range for channel 3 (terminals 3.1/3.2)		
23	Representation of measured values		<div style="background-color: #cccccc; display: inline-block; width: 1em; height: 1em; vertical-align: middle;"></div> Two's complement Amount with sign Binary

: Default setting in parameterization frame

<sup>1</sup> Byte address in parameterization frame of slave

### Where to Find a Description

Parameterization of the ET 200B-4AI with COM ET 200 V 4.x is described in detail in Section 4.2.

COM ET 200 WINDOWS also provides extensive support for parameterizing the ET 200B-4AI with COM ET 200 WINDOWS through its integrated help system.

Please refer to the *ET 200 Distributed I/O System* manual (Order No. 6ES5 998-3ES12) for further information about how to use COM ET 200 WINDOWS.

### Analog Value Representation

Analog values can be represented in three data formats with the ET 200B-4AI:

- 12-bit two's complement representation (range: -2048 to +2047 units)
- 11-bit amount and 1-bit sign (range: -2048 to +2047 units)
- 12-bit binary number (range: 0 to 4095 units)

Table 9-16 shows the analog value representation of the ET 200B-4AI:

Table 9-16 Representing an Analog Input Value as a Bit Pattern (6ES7 134-0HF00-0XB0)

	High Byte								Low Byte							
Bit number	15	14	13	12	11	10	9	8	7	6	5	4	3	2	1	0
Analog value representation	SI	2 <sup>11</sup>	2 <sup>10</sup>	2 <sup>9</sup>	2 <sup>8</sup>	2 <sup>7</sup>	2 <sup>6</sup>	2 <sup>5</sup>	2 <sup>4</sup>	2 <sup>3</sup>	2 <sup>2</sup>	2 <sup>1</sup>	2 <sup>0</sup>	X	X	OV

Bits 0 to 2 and bit 15 have no significance for the amount of the measured value. See Table 9-17 for a detailed description of these bits.

### Supplementary Bits

Bits 0 to 2 and bit 15 have the following meaning in the bit pattern of the analog input value:

Table 9-17 Description of the Bits (6ES7 134-0HF00-0XB0)

Bit	Meaning	Signal Status	Meaning of the Signal Status
OV	Overflow bit	1	Overrange <sup>1</sup>
SI	Sign	0	“+” sign
		1	“-” sign
X	Irrelevant	–	–

<sup>1</sup> In the event of overflow at one measuring point, the overflow bits of the other channels remain unaffected; this means the values of the other channels are correct and can be evaluated.

**Electronics Block ET 200B-4AI (6ES7 134-0HF00-0XB0), continued**

**Measured Value Table**

Tables 9-18 to 9-20 show the assignments of analog to digitized measured values for the measuring ranges:  
 $\pm 1.25\text{ V}$ ,  $\pm 2.5\text{ V}$ ,  $\pm 5\text{ V}$ ,  $\pm 10\text{ V}$ .

The ET 200B-4AI module (6ES7 134-0HF00-0XB0) has no overrange.

Table 9-18 Representation of Digitized Measured Values of the ET 200B-4AI (6ES7 134-0HF00-0XB0; Measuring Ranges:  $\pm 1.25\text{ V}$ ,  $\pm 2.5\text{ V}$ ,  $\pm 5\text{ V}$ ,  $\pm 10\text{ V}$ ; **Two's Complement**)

Units	Measured Value in V				Digitized Measured Value													X	X	OV	Range
	$\pm 1.25\text{V}$	$\pm 2.5\text{V}$	$\pm 5\text{V}$	$\pm 10\text{V}$	15	14	13	12	11	10	9	8	7	6	5	4	3				
2047	1.2494	2.4988	4.9976	9.9951	0	0	1	1	1	1	1	1	1	1	1	1	1	0	0	1	Nominal range
2046	1.2488	2.4975	4.9951	9.9902	0	0	1	1	1	1	1	1	1	1	1	1	0	0	0		
:	:	:	:	:	:													:	:	:	
1	0.0006	0.0012	0.0024	0.0049	0	0	0	0	0	0	0	0	0	0	0	0	1	0	0		
0	0.0000	0.0000	0.0000	0.0000	0	0	0	0	0	0	0	0	0	0	0	0	0	0	0		
-1	-0.0006	-0.0012	-0.0024	-0.0049	1	1	1	1	1	1	1	1	1	1	1	1	1	0	0		
:	:	:	:	:	:													:	:	:	
-2047	-1.2494	-2.4988	-4.9976	-9.9951	1	1	0	0	0	0	0	0	0	0	0	0	1	0	0		
-2048	-1.2500	-2.5000	-5.0000	-10.000	1	1	0	0	0	0	0	0	0	0	0	0	0	0	1		

Table 9-19 Representation of Digitized Measured Values of the ET 200B-4AI (6ES7 134-0HF00-0XB0; Measuring Ranges:  $\pm 1.25\text{ V}$ ,  $\pm 2.5\text{ V}$ ,  $\pm 5\text{ V}$ ,  $\pm 10\text{ V}$ ; **Amount and Sign**)

Units	Measured Value in V				SI	Digitized Measured Value													X	X	OV	Range
	$\pm 1.25\text{V}$	$\pm 2.5\text{V}$	$\pm 5\text{V}$	$\pm 10\text{V}$		15	14	13	12	11	10	9	8	7	6	5	4	3				
2047	1.2494	2.4988	4.9976	9.9951	0	0	1	1	1	1	1	1	1	1	1	1	1	0	0	1	Nominal range	
2046	1.2488	2.4975	4.9951	9.9902	0	0	1	1	1	1	1	1	1	1	1	1	0	0	0			
:	:	:	:	:	:													:	:	:		
1	0.0006	0.0012	0.0024	0.0049	0	0	0	0	0	0	0	0	0	0	0	0	1	0	0			
0	0.0000	0.0000	0.0000	0.0000	0	0	0	0	0	0	0	0	0	0	0	0	0	0	0			
-1	-0.0006	-0.0012	-0.0024	-0.0049	1	0	0	0	0	0	0	0	0	0	0	0	1	0	0			
:	:	:	:	:	:													:	:	:		
-2047	-1.2494	-2.4988	-4.9976	-9.9951	1	0	1	1	1	1	1	1	1	1	1	1	1	0	0			
-2048	-1.2500	-2.5000	-5.0000	-10.000	1	1	0	0	0	0	0	0	0	0	0	0	0	0	1			



Table 9-20 Representation of Digitized Measured Values of the ET 200B-4AI (6ES7 134-0HF00-0XB0; Measuring Ranges:  $\pm 1.25$  V,  $\pm 2.5$  V,  $\pm 5$  V,  $\pm 10$  V; **Binary**)

Units	Measured Value in V				Digitized Measured Value										OV	Range					
	$\pm 1.25$ V	$\pm 2.5$ V	$\pm 5$ V	$\pm 10$ V	15	14	13	12	11	10	9	8	7	6			5	4	3	2	1
4095	1.2494	2.4988	4.9976	9.9951	0	1	1	1	1	1	1	1	1	1	1	1	1	0	0	1	Nominal range
4094	1.2488	2.4975	4.9951	9.9902	0	1	1	1	1	1	1	1	1	1	1	1	0	0	0		
:	:	:	:	:	:										:	:					
2049	0.0006	0.0012	0.0024	0.0049	0	1	0	0	0	0	0	0	0	0	0	0	0	1	0	0	
2048	0.0000	0.0000	0.0000	0.0000	0	1	0	0	0	0	0	0	0	0	0	0	0	0	0	0	
2047	-0.0006	-0.0012	-0.0024	-0.0049	0	0	1	1	1	1	1	1	1	1	1	1	1	0	0	0	
:	:	:	:	:	:										:	:					
1	-1.2494	-2.4988	-4.9976	-9.9951	0	0	0	0	0	0	0	0	0	0	0	0	0	1	0	0	
0	-1.2500	-2.5000	-5.0000	-10.000	0	0	0	0	0	0	0	0	0	0	0	0	0	0	0	1	

**Electronics Block ET 200B-4AI (6ES7 134-0HF00-0XB0), continued**

**Measured Value Table**

Tables 9-21 to 9-25 show the assignments of analog to digitized measured values for the measuring ranges:  
0 to 20 mA, 4 to 20 mA,  $\pm 20$  mA.

The ET 200B-4AI module (6ES7 134-0HF00-0XB0) has no overrange.

Table 9-21 Representation of Digitized Measured Values of the ET 200B-4AI (6ES7 134-0HF00-0XB0; Measuring Range:  $\pm 20$  mA; Two's Complement)

Units	Measured Value in mA	Digitized Measured Value											X	X	OV	Range	
		15	14	13	12	11	10	9	8	7	6	5					4
$\pm 20$ mA																	
2047	19.9902	0	0	1	1	1	1	1	1	1	1	1	1	1	0	0	1
2046	19.9804	0	0	1	1	1	1	1	1	1	1	1	1	0	0	0	
:	:																
1	0.00976	0	0	0	0	0	0	0	0	0	0	0	0	1	0	0	
0	0.0000	0	0	0	0	0	0	0	0	0	0	0	0	0	0	0	
-1	-0.00976	1	1	1	1	1	1	1	1	1	1	1	1	1	0	0	
:	:																
-2047	-19.9902	1	1	0	0	0	0	0	0	0	0	0	0	1	0	0	
-2048	-20.0000	1	1	0	0	0	0	0	0	0	0	0	0	0	0	1	

Table 9-22 Representation of Digitized Measured Values of the ET 200B-4AI  
(6ES7 134-0HF00-0XB0; Measuring Range:  $\pm 20$  mA;  
Amount and Sign)

Units	Measured Value in mA $\pm 20$ mA	SI	Digitized Measured Value											X	X	OV	Range		
			15	14	13	12	11	10	9	8	7	6	5					4	3
2047	19.9902	0	0	1	1	1	1	1	1	1	1	1	1	1	1	0	0	1	Nominal range
2046	19.9804	0	0	1	1	1	1	1	1	1	1	1	1	1	0	0	0		
:	:																		
1	0.00976	0	0	0	0	0	0	0	0	0	0	0	0	0	1	0	0		
0	0.0000	0	0	0	0	0	0	0	0	0	0	0	0	0	0	0	0		
-1	-0.00976	1	0	0	0	0	0	0	0	0	0	0	0	0	0	1	0	0	
:	:																		
-2047	-19.9902	1	0	1	1	1	1	1	1	1	1	1	1	1	0	0	0		
-2048	-20.0000	1	1	0	0	0	0	0	0	0	0	0	0	0	0	0	1		

Table 9-23 Representation of Digitized Measured Values of the ET 200B-4AI  
(6ES7 134-0HF00-0XB0; Measuring Range:  $\pm 20$  mA; Binary)

Units	Measured Value in mA $\pm 20$ mA	Digitized Measured Value											X	X	OV	Range		
		15	14	13	12	11	10	9	8	7	6	5					4	3
4095	19.9902	0	1	1	1	1	1	1	1	1	1	1	1	1	0	0	1	Nominal range
4094	19.9804	0	1	1	1	1	1	1	1	1	1	1	1	0	0	0		
:	:																	
2049	0.00976	0	1	0	0	0	0	0	0	0	0	0	0	1	0	0		
2048	0.0000	0	1	0	0	0	0	0	0	0	0	0	0	0	0	0		
2047	-0.00976	0	0	1	1	1	1	1	1	1	1	1	1	1	0	0	0	
:	:																	
1	-19.9902	0	0	0	0	0	0	0	0	0	0	0	0	0	1	0	0	
0	-20.0000	0	0	0	0	0	0	0	0	0	0	0	0	0	0	0	1	

**Electronics Block ET 200B-4AI (6ES7 134-0HF00-0XB0), continued**

Table 9-24 Representation of Digitized Measured Values of the ET 200B-4AI (6ES7 134-0HF00-0XB0; Measuring Range: 0 to 20 mA)

Units	Measured Value in mA	Digitized Measured Value <sup>1</sup>											X	X	OV	Range	
		15	14	13	12	11	10	9	8	7	6	5					4
	<b>0 to 20 mA</b>																
4095	19.9951	0	1	1	1	1	1	1	1	1	1	1	1	0	0	1	Nominal range
4094	19.9902	0	1	1	1	1	1	1	1	1	1	1	0	0	0	0	
:	:																
1	0.00488	0	0	0	0	0	0	0	0	0	0	0	0	1	0	0	
0	0 . 0 0 0	0	0	0	0	0	0	0	0	0	0	0	0	0	0	1	

<sup>1</sup> Same representation for two's complement, amount and sign, and binary

Table 9-25 Representation of Digitized Measured Values of the ET 200B-4AI (6ES7 134-0HF00-0XB0; Measuring Range: 4 to 20 mA)

Units	Measured Value in mA	Digitized Measured Value <sup>1</sup>											X	X	OV	Range	
		15	14	13	12	11	10	9	8	7	6	5					4
	<b>4 to 20 mA</b>																
2559	19.992	0	1	0	0	1	1	1	1	1	1	1	1	0	0	1	Nominal range
2048	16.000	0	1	0	0	0	0	0	0	0	0	0	0	0	0	0	
512	4.000	0	0	0	1	0	0	0	0	0	0	0	0	0	0	0	
511	3.992	0	0	0	0	1	1	1	1	1	1	1	1	0	0	0	
384	3.000	0	0	0	0	1	1	0	0	0	0	0	0	0	0	0	
383	2.992	0	0	0	0	1	0	1	1	1	1	1	1	0	0	0	
0	0.000	0	0	0	0	0	0	0	0	0	0	0	0	0	0	1	

<sup>1</sup> Same representation for two's complement, amount and sign, and binary

**Note**

The measuring range 4 to 20 mA is resolved to 2048 units in the interval 512 to 2560. For a representation in the range 0 to 2048 units, 512 units must be subtracted per software.

**Schematic Circuit Diagram**

Simplified representation of potential for the ET 200B-4AI and TB8:

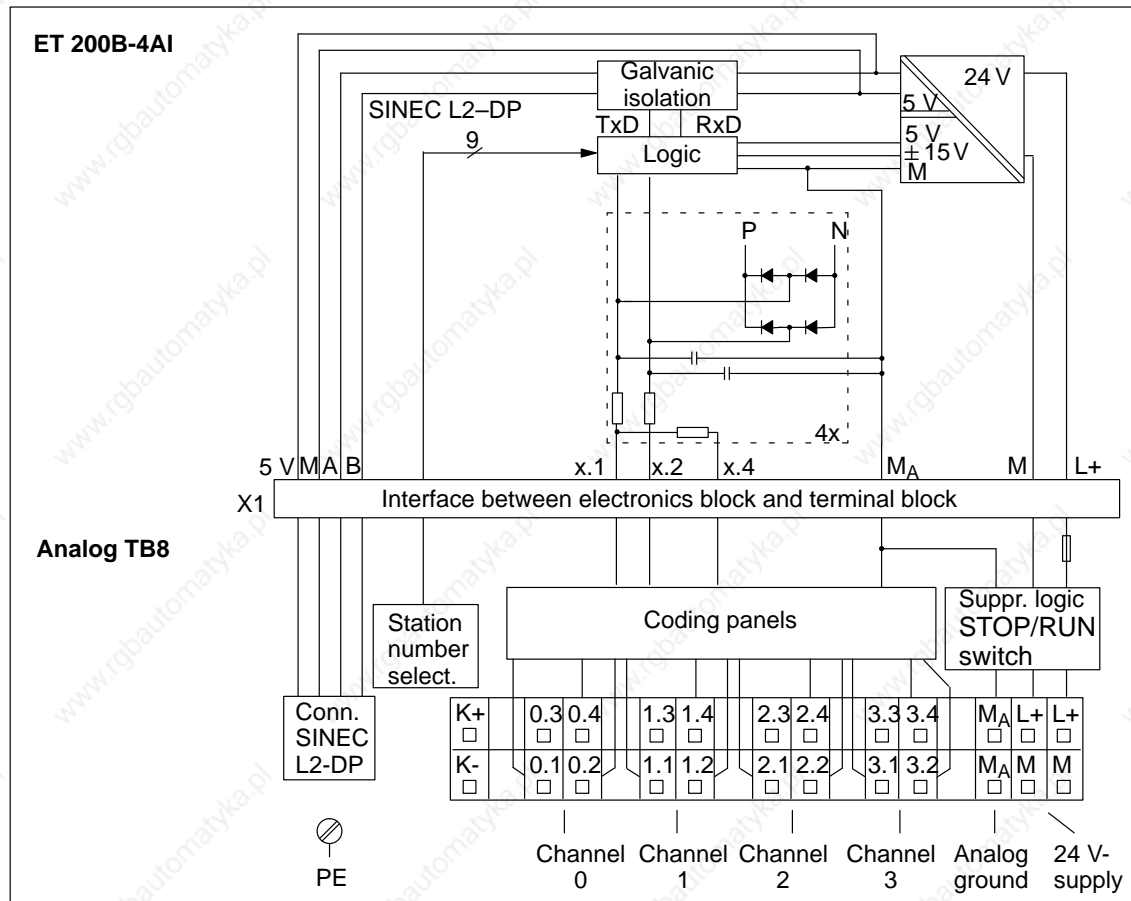

Figure 9-20 Schematic Circuit Diagram: ET 200B-4AI (6ES7 134-0HF00-0XB0) and TB8

**Electronics Block ET 200B-4AI (6ES7 134-0HF00-0XB0), continued****Terminal Assignments**

The ET 200B-4AI is plugged into the TB8.

Table 9-26 contains the terminal assignments of the TB8 for the ET 200B-4AI.

Table 9-26 Terminal Assignments of the TB8 for ET 200B-4AI  
(6ES7 134-0HF00-0XB0)

Terminal	Assignment
K+	Unassigned
K-	Unassigned
x.1	Measuring line (+)
x.2	Measuring line (-)
x.3	Unassigned
x.4	Connection of current resistance
M <sub>A</sub>	Analog ground (M <sub>A</sub> )
L+	Voltage supply for internal logic
M	Voltage supply for internal logic

x = 0, 1, 2, 3

---

**Note**

You must make additional settings for the input circuits of the TB8 via coding plugs. See Figures 9-16 to 9-19 for the necessary settings of the coding plugs.

---

Technical specifications		Inputs, continued	
Baud rates	9.6/19.2/93.75/187.5/500/1500 kbps	Measured value representation	Can be switched between following data formats: 12-bit two's complement, 11-bit amount with sign, 12-bit binary
Bus protocol	DP Standard	Measuring principle	Successive approximation
Galvanic isolation to SINEC L2-DP bus	Yes	Conversion time	Max. 100 $\mu$ s
Power losses	Typ. 1.8 W	Module cycle time	Approx. 2 ms
Weight (EB and TB)	Approx. 550 g (19.25 oz.)	Permissible potential difference	
Dimensions (EB and TB): W x H x D)	160 x 130 x 60 mm (6.24 x 5.07 x 2.34 in.)	<ul style="list-style-type: none"> <li>Inputs to each other</li> <li>Inputs to <math>M_A</math> (<math>V_{CM}</math>)</li> <li><math>M_A</math> to PE or M</li> </ul>	Max. $\pm$ 10 V Max. $\pm$ 1 V Max. 75 V DC/60 V AC
Diagnostics functions		Fault message in event of	
Voltage monitoring	Green "RUN" LED	<ul style="list-style-type: none"> <li>Ovrange</li> <li>Wire break of signal sensor lines</li> </ul>	Yes No
Bus monitoring SINEC L2-DP	Red "BF" LED	Noise suppression for $f = n \times (50/60 \text{ Hz} \pm 1\%)$ $n = 1, 2, \dots$	
Group diagnostics	Red "DIA" LED, parameterizable	<ul style="list-style-type: none"> <li>Common mode noise (<math>V_{PP} &lt; 1 \text{ V}</math>)</li> </ul>	Min. 70 dB
Supply voltage for inputs and internal logic		Basic error limit	
Supply voltage (L+)		<ul style="list-style-type: none"> <li>Voltage ranges</li> <li>Current range</li> </ul>	0.15 % 0.20 %
<ul style="list-style-type: none"> <li>Rated value</li> <li>Permissible range</li> <li>Value for <math>t &lt; 0.5\text{s}</math></li> </ul>	24 V DC 18.5 to 30.2 V 35 V	Working error limit (0 to 60 °C) (32 to 140 °F)	
Current consumption from L+		<ul style="list-style-type: none"> <li>Voltage ranges</li> <li>Current range</li> </ul>	0.32 % 0.41 %
<ul style="list-style-type: none"> <li>Logic</li> </ul>	70 mA	Permissible input voltage (destruction limit)	Max. $\pm$ 30 V (static) <b>or</b> $\pm$ 75 V (pulse for max. 1 ms and mark-space ratio 1:20)
Inputs		Permissible input current (destruction limit)	Max. 40 mA
Number of inputs	4	Cable length	
Galvanic isolation to internal electronic circuits	No	<ul style="list-style-type: none"> <li>Shielded</li> </ul>	Max. 100 m (328 ft.)
Galvanic isolation to voltage supply of internal logic	Yes		
Measured value ranges			
<ul style="list-style-type: none"> <li>Voltage sensors</li> <li>Current sensors</li> </ul>	$\pm 1.25 \text{ V}, \pm 2.5 \text{ V}, \pm 5 \text{ V},$ $\pm 10 \text{ V}$ 0 to 20 mA, 4 to 20 mA, $\pm 20 \text{ mA}$		
Method of connecting signal sensors	2-wire connection		
Input resistance			
<ul style="list-style-type: none"> <li>Voltage measurement</li> <li>Current measurement</li> </ul>	$\geq 100 \text{ k}\Omega$ 125 $\Omega$		

### 9.1.5 Electronics Block ET 200B-4AO (6ES7 135-0HF00-0XB0)

#### Characteristics

The ET 200B-4AO electronics block has the following features:

- 4 inputs, floating to the supply voltage of the internal logic
- Output ranges:  $\pm 10\text{ V}$ ,  $0\text{ to }10\text{ V}$ ,  $\pm 20\text{ mA}$ ,  $0\text{ to }20\text{ mA}$ ,  $4\text{ to }20\text{ mA}$
- Supply voltage:  $24\text{ V DC}$
- Loads connectable in
  - 4-wire connection
  - 2-wire connection
- Measuring range set via COM ET 200

#### Dimension Drawing

See Figure 9-5 for the precise dimensions.

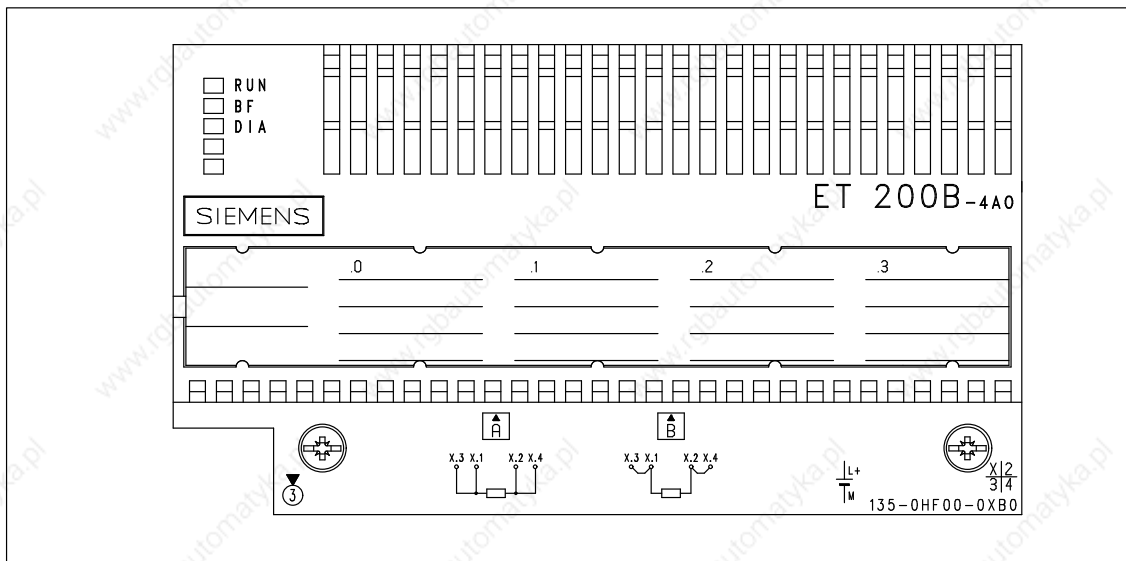

Figure 9-21 Front Elevation: ET 200B-4AO (6ES7 135-0HF00-0XB0)



**Possible Connections**

There are two methods of connecting loads to the ET 200B-4AO:

- 4-wire connection of loads
- 2-wire connection of loads

**On the Following Pages**

The following pages contain a connection example for every connection possibility. Please note the following rules.

**Rules**

Please note the following rules when connecting loads to the ET 200B-4AO:

- The output terminals  $x.2$  ( $x = 0$  to  $3$ ) have a fixed connection to analog ground ( $M_A$ ).  
If non-floating loads are connected to a common reference potential, please ensure minimum potential differences. Failure to do so can lead to undesired transient currents across the output module.
- You are recommended to connect floating-ground loads which are floating with reference to each other. In such cases, connect analog ground ( $M_A$ ) with PE ( $\text{⏏}$ ) to enhance noise immunity.
- The connection terminals of unused outputs are left open.
- You must short-circuit terminals “K+” and “K-”. For this purpose, set the coding plug to the “C” position.

**Caution**

If the supply voltage is below the lower tolerance limit, the output analog values can deviate from the specified values.

**Note**

Please note the explanation of shielding of analog lines in Sections 3.1 and 3.5.

## Electronics Block ET 200B-4AO (6ES7 135-0HF00-0XB0), continued

### 4-Wire Connection of Loads (Voltage Output)

The voltage on the load is re-adjusted via two high-resistance sensor lines per channel (S+, S- at terminals x.3 and x.4). In this way, voltage drops of up to 3 V per line can be re-adjusted.

Please ensure that the sensor lines are connected directly to the load.

4-wire connection of loads in the case of voltage output is shown below:

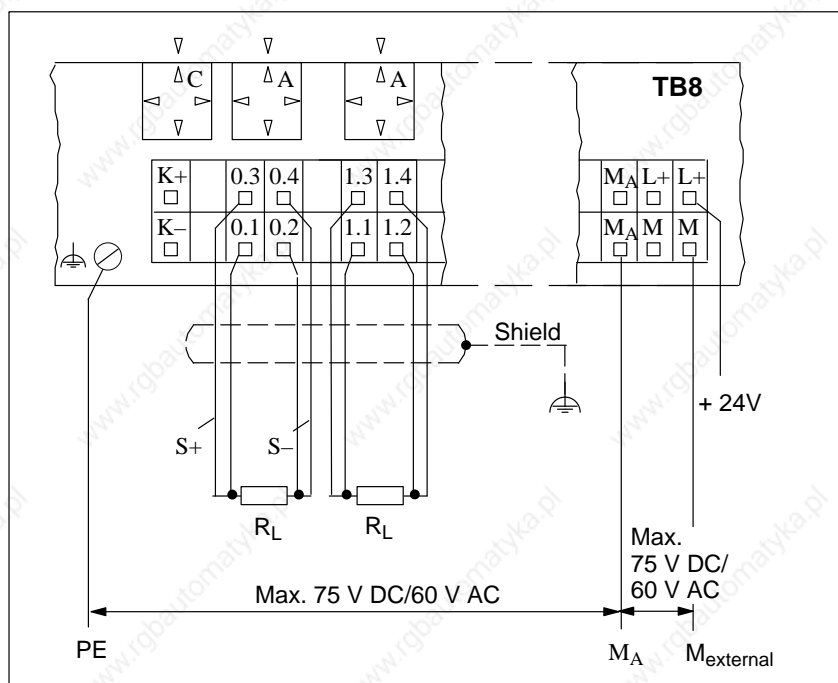
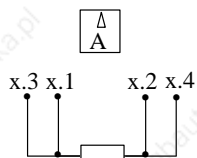

Figure 9-22 4-Wire Connection of Loads in the Case of Voltage Output

**2-Wire Connection of Loads (Voltage Output)**

The sensor lines are not required for 2-wire connection. Two-wire connection is possible for voltage output if the line resistance of the signal lines is negligible compared to the load resistance.

2-wire connection of loads in the case of voltage output is shown below:

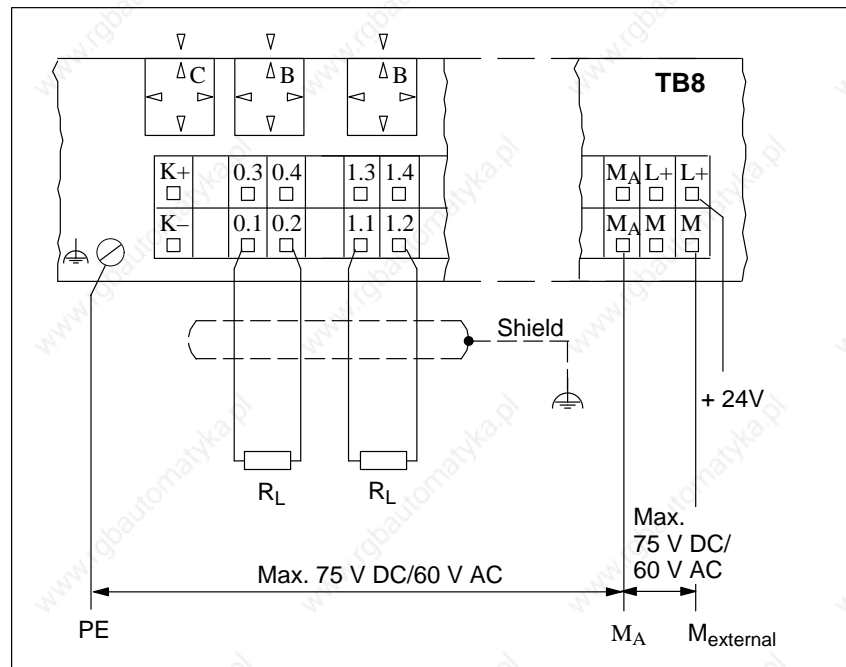
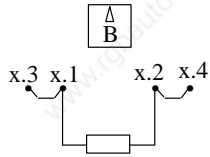

Figure 9-23 2-Wire Connection of Loads in the Case of Voltage Output

## Electronics Block ET 200B-4AO (6ES7 135-0HF00-0XB0), continued

### Two-Wire Connection of Loads (Current Output)

Two-wire connection of loads in the case of current output is shown below:

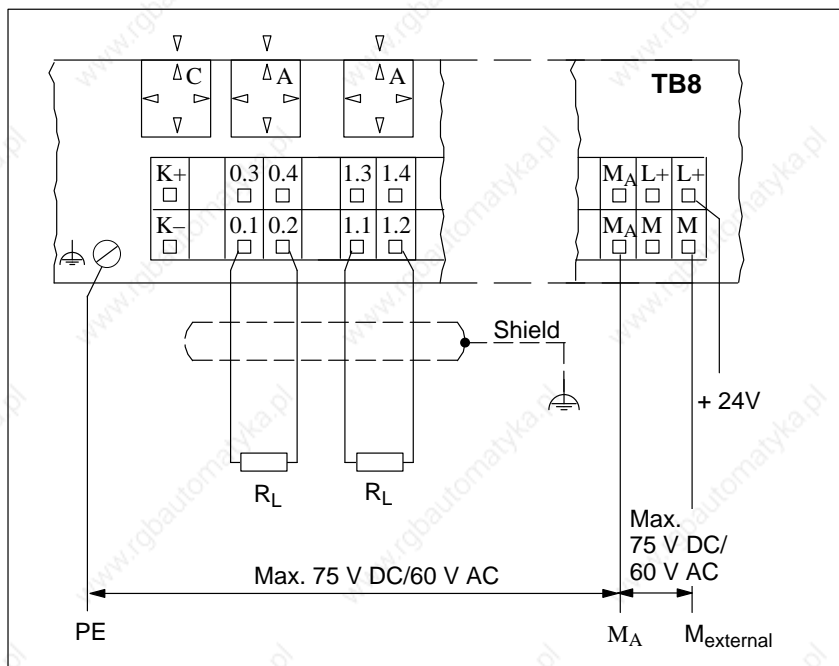
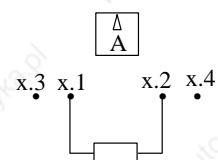

Figure 9-24 2-Wire Connection of Loads in the Case of Current Output

**Parameterization** You can define the functional principle of the ET 200B-4AO with the COM ET 200 parameterization software.

Table 9-27 shows all the parameters for the ET 200B-4AO:

Table 9-27 Parameters for the ET 200B-4AO

Byte <sup>1</sup>	Parameter	Explanation	Value Range	
3 (Bit 0)	Diagnostics enable for channel 0 (terminals 0.1/0.2)	Diagnostics messages enabled separately for each channel	<input checked="" type="checkbox"/> Disable <input type="checkbox"/> Enable	
3 (Bit 1)	Diagnostics enable for channel 1 (terminals 1.1/1.2)			
3 (Bit 2)	Diagnostics enable for channel 2 (terminals 2.1/2.2)			
3 (Bit 3)	Diagnostics enable for channel 3 (terminals 3.1/3.2)			
7	Output method and range for channel 0 (terminals 0.1/0.2)	You can set the output method and range separately for each channel	<input checked="" type="checkbox"/> $\pm 10\text{ V}$ 0 to 10 V  <input type="checkbox"/> $\pm 20\text{ mA}$ 0 to 20 mA 4 to 20 mA	
8	Output method and range for channel 1 (terminals 1.1/1.2)			For voltage output:
9	Output method and range for channel 2 (terminals 2.1/2.2)			For current output:
10	Output method and range for channel 3 (terminals 3.1/3.2)			

: Default setting in parameterization frame

<sup>1</sup> Byte address in parameterization frame of slave

### Where to Find a Description

Parameterization of the ET 200B-4AO with COM ET 200 V 4.x is described in detail in Section 4.2.

COM ET 200 WINDOWS also provides extensive support for parameterizing the ET 200B-4AO with COM ET 200 WINDOWS through its integrated help system.

Please refer to the *ET 200 Distributed I/O System* manual (Order No. 6ES5 998-3ES12) for further information about how to use COM ET 200 WINDOWS.

## Electronics Block ET 200B-4AO (6ES7 135-0HF00-0XB0), continued

### Analog Value Representation

Analog values can be represented in two's complement with the ET 200B-4AO.

Table 9-28 shows the analog value representation of the ET 200B-4AO:

Table 9-28 Representing an Analog Input Value as a Bit Pattern (6ES7 135-0HF00-0XB0)

	High Byte								Low Byte							
Bit number	15	14	13	12	11	10	9	8	7	6	5	4	3	2	1	0
Analog value representation	SI	$2^{10}$	$2^9$	$2^8$	$2^7$	$2^6$	$2^5$	$2^4$	$2^3$	$2^2$	$2^1$	$2^0$	X	X	X	X

Bits 0 to 3 and bit 15 have no significance for the amount of the measured value. See Table 9-29 for a detailed description of these bits.

### Supplementary Bits

Bits 0 to 3 and bit 15 have the following meaning in the bit pattern of the analog input value:

Table 9-29 Description of the Bits (6ES7 135-0HF00-0XB0)

Bit	Meaning	Signal Status	Meaning of the Signal Status
SI	Sign	0	“+” sign
		1	“-” sign
X	Irrelevant	–	–

**Measured Value Table**

Table 9-30 shows the assignments of analog to digitized output signals for the value ranges:  $\pm 10$  V, 0 to 10 V,  $\pm 20$  mA, 0 to 20 mA, 4 to 20 mA.

Table 9-30 Analog Output Signals of the ET 200B-4AO (Value Ranges:  $\pm 10$  V, 0 to 10 V,  $\pm 20$  mA, 0 to 20 mA, 4 to 20 mA; **Two's Complement**)

Units	Measured Value in mV					Digitized Measured Value										Range		
	0 to 20 mA	4 to 20 mA	$\pm 20$ mA	0 to 10 V	$\pm 10$ V	15	14	13	12	11	10	9	8	7	6		5	4
1249		23.52				0	1	0	0	1	1	1	0	0	0	0	1	Over-range
1204	23.52	:	23.52	11.758	11.758	0	1	0	0	1	0	1	1	0	1	0	0	
:	:	:	:	:	:								:					
1025	20.0195	20.016	20.2	10.0098	10.0098	0	1	0	0	0	0	0	0	0	0	0	1	
1024	20.0	20.0	20.0	10.00	10.00	0	1	0	0	0	0	0	0	0	0	0	0	Nominal range
1023	19.98	19.98	19.98	9.99	9.990	0	0	1	1	1	1	1	1	1	1	1	1	
512	10.0	12.0	10.0	5.00	5.000	0	0	1	0	0	0	0	0	0	0	0	0	
256	5.0	8.00	5.0	2.50	2.500	0	0	0	1	0	0	0	0	0	0	0	0	
1	0.0195	4.015	0.02	0.0098	0.0098	0	0	0	0	0	0	0	0	0	0	0	0	
0	0.0	4.0	0.0	0.0	0.000	0	0	0	0	0	0	0	0	0	0	0	0	
-1	0.0	3.984	-0.02	0.0	-0.0098	1	1	1	1	1	1	1	1	1	1	1	1	
-256	0.0	0.0	-05.0	0.0	-2.500	1	1	1	1	0	0	0	0	0	0	0	0	
-512	0.0	0.0	-10.0	0.0	-5.000	1	1	1	0	0	0	0	0	0	0	0	0	
-1024	0.0	0.0	-20.00	0.0	-10.000	1	1	0	0	0	0	0	0	0	0	0	0	
-1025	0.0	0.0	-20.02	0.0	-10.009	1	0	1	1	1	1	1	1	1	1	1	1	Over-range
:	:	:	:	:	:								:					
-1204	0.0	0.0	-23.52	0.0	-11.758	1	0	1	1	0	1	0	0	1	1	0	0	

### Electronics Block ET 200B-4AO (6ES7 135-0HF00-0XB0), continued

**Schematic Circuit Diagram** Simplified representation of potential for the ET 200B-4AO and TB8:

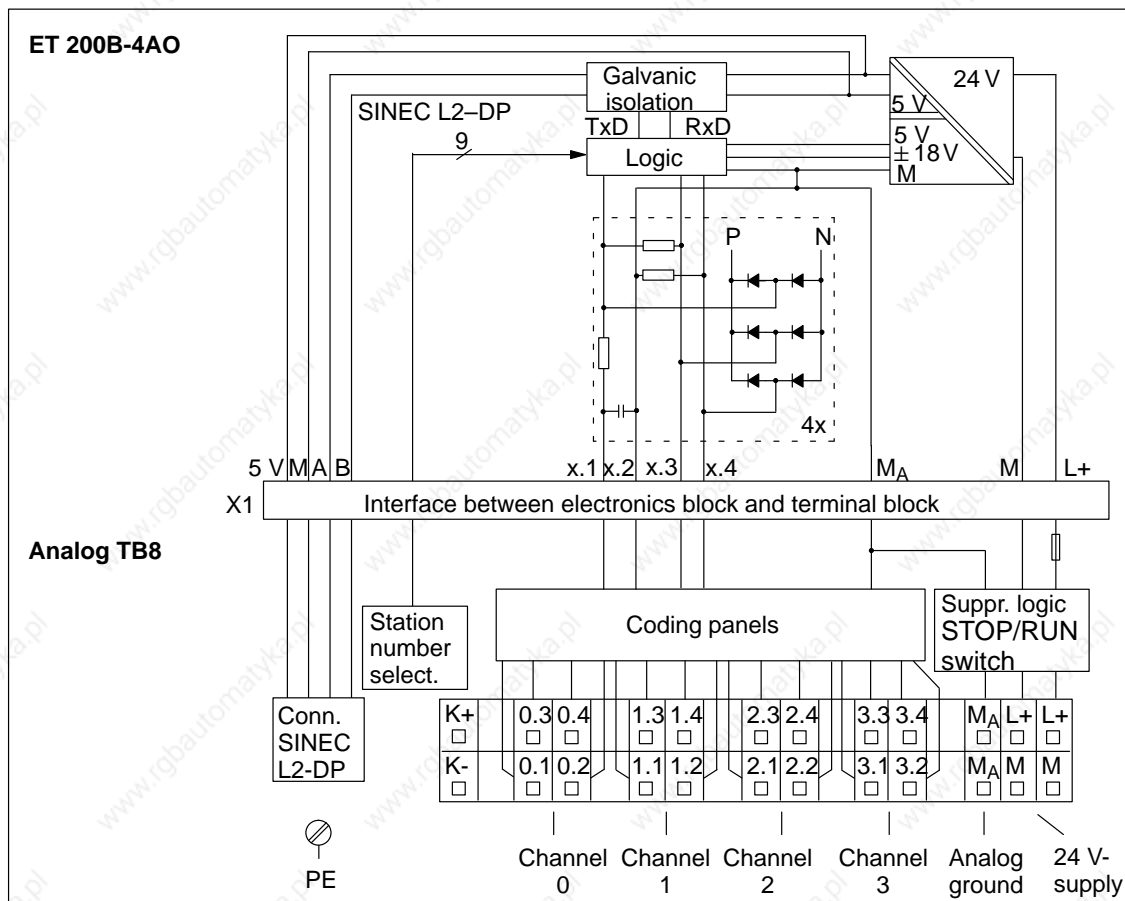

Figure 9-25 Schematic Circuit Diagram: ET 200B-4AO (6ES7 135-0HF00-0XB0) and TB8



## Terminal Assignments

The ET 200B-4AO is plugged into the TB8.

Table 9-31 contains the terminal assignments of the TB8 for the ET 200B-4AO depending on the connection method.

Table 9-31 Terminal Assignments of the TB8 for ET 200B-4AO  
(6ES7 135-0HF00-0XB0)

Terminal	4-Wire Connection	2-Wire Connection
K+	Unassigned	
K-	Unassigned	
x.1	Analog output "voltage" (+)	Analog output "current or voltage" (+)
x.2	Analog output "voltage" (-)	Analog output "current or voltage" (-)
x.3	Sensor line (S+)	Unassigned
x.4	Sensor line (S-)	Unassigned
M <sub>A</sub>	Analog ground (M <sub>A</sub> )	
L+	Voltage supply for internal logic	
M	Voltage supply for internal logic	

x = 0, 1, 2, 3

### Note

You must make additional settings for the input circuits of the TB8 via coding plugs. See Figures 9-22 and 9-24 for the necessary settings of the coding plugs.

## Electronics Block ET 200B-4AO (6ES7 135-0HF00-0XB0), continued

Technical specifications		Outputs, continued	
Baud rates	9.6/19.2/93.75/187.5/500/1500 kbps	Data input format	11-bit two's complement
Bus protocol	DP Standard	Overrange	Approx. 17.5 %
Galvanic isolation to SINEC L2-DP bus	Yes	Conversion time	Approx. 1 ms
Power losses	Typ. 2.4 W	Settling time	
Weight (EB and TB)	Approx. 550 g (19.25 oz.)	<ul style="list-style-type: none"> <li>For resistive load</li> <li>For capacitive load</li> <li>For inductive load</li> </ul>	<ul style="list-style-type: none"> <li>0.1 ms</li> <li>3.3 ms</li> <li>0.5 ms</li> </ul>
Dimensions (EB and TB: W x H x D)	160 x 130 x 60 mm (6.24 x 5.07 x 2.34 in.)	Permissible potential difference	
<b>Diagnostics functions</b>		<ul style="list-style-type: none"> <li>M<sub>A</sub> to PE or M</li> </ul>	Max. 75 V DC/60 V AC
Voltage monitoring	Green "RUN" LED	Crosstalk between outputs	40 dB
Bus monitoring SINEC L2-DP	Red "BF" LED	Working error limit (over entire temperature range in relation to output range)	
Group diagnostics	Red "DIA" LED, parameterizable	<ul style="list-style-type: none"> <li>Voltage</li> <li>Current</li> </ul>	<ul style="list-style-type: none"> <li>± 0.5 %</li> <li>± 1 %</li> </ul>
<b>Supply voltage for outputs and internal logic</b>		Basic error limit (working error limit at 25°C (77 °F) in relation to output range)	
Supply voltage (L+)		<ul style="list-style-type: none"> <li>Voltage</li> <li>Current</li> </ul>	<ul style="list-style-type: none"> <li>± 0.2 %</li> <li>± 0.3 %</li> </ul>
<ul style="list-style-type: none"> <li>Rated value</li> <li>Permissible range</li> <li>Value for t &lt; 0.5s</li> </ul>	<ul style="list-style-type: none"> <li>24 V DC</li> <li>18.5 to 30.2 V</li> <li>35 V</li> </ul>	Temperature error (in relation to output range)	± 0.02 %/K
Current consumption from L+		Linearity error (in relation to output range)	± 0.05 %
<ul style="list-style-type: none"> <li>Logic</li> </ul>	Max. 200 mA	Repeatability (in steady-state condition at 25°C (77 °F), in relation to output range)	± 0.05 %
<b>Outputs</b>		Output ripple (in relation to output range)	± 0.05 %
Number of outputs	4	Voltage output	
Galvanic isolation to internal electronic circuits	No	<ul style="list-style-type: none"> <li>Short-circuit protection</li> <li>Short-circuit current</li> </ul>	<ul style="list-style-type: none"> <li>Yes, max. 1 output simultaneously</li> <li>Max. 25 mA</li> </ul>
Galvanic isolation to voltage supply of internal logic	Yes	Current output	
Output ranges		<ul style="list-style-type: none"> <li>Idle voltage</li> </ul>	Max. 18 V
<ul style="list-style-type: none"> <li>Voltage range</li> <li>Current range</li> </ul>	<ul style="list-style-type: none"> <li>± 10 V, 0 to 10 V</li> <li>± 20 mA, 0 to 20 mA, 4 to 20 mA</li> </ul>	Cable length	
Method of connecting signal sensors	2-wire or 4-wire connection	<ul style="list-style-type: none"> <li>Shielded</li> </ul>	Max. 100 m (.328 ft.)
Load resistance			
<ul style="list-style-type: none"> <li>Voltage output</li> <li>Load impedance in case of current output</li> <li>Capacitive load</li> <li>Inductive load</li> </ul>	<ul style="list-style-type: none"> <li>Min. 3.3 kΩ</li> <li>Max. 300 Ω</li> <li>Max. 1 μF</li> <li>Max. 1 mH</li> </ul>		

# Type Files

# A

## Installing the Type Files

All the type files required for starting up the ET 200B with COM ET 200 V4.x and COM ET 200 WINDOWS are made available centrally in the Interface Center, from where you can pick them up by modem under the following mailbox number:

Tel.: (Germany) 0911/73-7972

## Installing the GSD Files

You need a device master data file (GSD file) in accordance with DIN E 19245, Part 3, to connect ET 200B modules to DP masters which are not able to process the type files (e.g. DP masters not manufactured by Siemens). All the device master data for the ET 200U/B/C is available on floppy disk and can be ordered under the following number:

Device master data disk: 6ES7 190-1AA00-0AA0

You can also pick up all device master data from the Interface Center by modem under the following mailbox number:

Tel.: (Germany) 0911/73-7972

## In this Chapter

The contents of all the type files needed to start up the system with COM ET 200 V4.x are reproduced in this chapter. If any of the files for this version of COM ET 200 are missing, you can thus create them yourself if necessary using an ASCII editor.

Please refer to Section 4.1 for further information about installing the type files for COM ET 200 V4.x.

All the type files necessary to start up the ET 200B with COM ET 200 WINDOWS are component parts of COM ET 200 WINDOWS; you thus do not need to install them separately.

## A.1 Contents of the type file for the COM ET 200 V4.x

### Introduction

The contents of the type files for all the ET 200B station types are reproduced in this chapter.

Please pay careful attention to the blanks and line breaks if you edit the type files. If you edit a type file incorrectly, COM ET 200 V4.x will output the following message:

”File format incorrect”

Please use the file names specified next to the station types for the type files (e.g. SI0001TD.200 for the ET 200B-16DI) and copy the files to the COM ET 200 directory.

**SI0001TD.200**

Contents of the type file for the ET 200B-16DI (6ES7 131-0BH00-0XB0):

Type file for ET 200B-16DI: SI0001TD.200:	[No. of char]
ET200B-16DI 3ms, MLFB<6ES7 131-0BH00-0XB0>, Siemens slave	[80 characters]
V4.0;	[4 characters]
B-16DI 3.0 DP;	[17 characters]
SIEMENS ;	[10 characters]
SIMATIC ;	[10 characters]
ET 200 ;	[10 characters]
ET200B/24V/DP ;	[15 characters]
00001;	[5 characters]
J;	[1 character]
J;	[1 character]
N;	[1 character]
J;	[1 character]
J;	[1 character]
J;	[1 character]
N;	[1 character]
N;	[1 character]
N;	[1 character]
N;	[1 character]
N;	[1 character]
N;	[1 character]
N;	[1 character]
N;	[1 character]
00000;	[5 characters]
1111011111;	[10 characters]
032;	[3 characters]
032;	[3 characters]
032;	[3 characters]
016;	[3 characters]
012;	[3 characters]
PV005;	[5 characters]
00;	[2 characters]
00;	[2 characters]
00;	[2 characters]
00;	[2 characters]
00;	[2 characters]
PSL000;	[6 characters]
KV000;	[5 characters]
SY;	[2 characters]
DKM000;	[6 characters]

## Type Files for COM ET 200 V4.x (continued)

## SI0004TD.200

Contents of the type file for the ET 200B-32DI (6ES7 131-0BL00-0XB0):

Type file for ET 200B-32DI: SI0004TD.200	[No. of char]
ET200B-32DI, MLFB<6ES7 131-0BL00-0XB0>, Siemens slave	[80 characters]
V4.0;	[4 characters]
B-32DI DP;	[17 characters]
SIEMENS ;	[10 characters]
SIMATIC ;	[10 characters]
ET 200 ;	[10 characters]
ET200B/24V/DP ;	[15 characters]
00004;	[5 characters]
J;	[1 character]
J;	[1 character]
N;	[1 character]
J;	[1 character]
J;	[1 character]
J;	[1 character]
N;	[1 character]
N;	[1 character]
N;	[1 character]
N;	[1 character]
N;	[1 character]
N;	[1 character]
N;	[1 character]
N;	[1 character]
00000;	[5 characters]
1111011111;	[10 characters]
032;	[3 characters]
032;	[3 characters]
032;	[3 characters]
016;	[3 characters]
012;	[3 characters]
PV005;	[5 characters]
00;	[2 characters]
00;	[2 characters]
00;	[2 characters]
00;	[2 characters]
00;	[2 characters]
PSL000;	[6 characters]
KV000;	[5 characters]
SY;	[2 characters]
DKM000;	[6 characters]

**SI000CTD.200**

Contents of the type file for the ET 200B-32DI 0.2ms  
(6ES7 131-0BL10-0XB0):

Type file for ET 200B-32DI 0.2ms: SI000CTD.200	[No. of char]
ET200B-32DI 0,2ms, MLFB<6ES7 131-0BL10-0XB0>, Siemens slave	[80 characters]
V4.0;	[4 characters]
B-32DI.2 DP;	[17 characters]
SIEMENS ;	[10 characters]
SIMATIC ;	[10 characters]
ET 200 ;	[10 characters]
ET200B/24V/DP ;	[15 characters]
00012;	[5 characters]
J;	[1 character]
J;	[1 character]
N;	[1 character]
J;	[1 character]
J;	[1 character]
J;	[1 character]
N;	[1 character]
N;	[1 character]
N;	[1 character]
N;	[1 character]
N;	[1 character]
N;	[1 character]
N;	[1 character]
N;	[1 character]
N;	[1 character]
00000;	[5 characters]
1111011111;	[10 characters]
032;	[3 characters]
032;	[3 characters]
032;	[3 characters]
016;	[3 characters]
012;	[3 characters]
PV005;	[5 characters]
00;	[2 characters]
00;	[2 characters]
00;	[2 characters]
00;	[2 characters]
00;	[2 characters]
PSL000;	[6 characters]
KV000;	[5 characters]
SY;	[2 characters]
DKM000;	[6 characters]

## Type Files for COM ET 200 V4.x (continued)

**SI0002TD.200** Contents of the type file for the ET 200B-16DO (6ES7 132-0BH00-0XB0):

Type file for ET 200B-16DO: SI0002TD.200	[No. of char]
ET200B-16DO 0,5A, MLFB<6ES7 132-0BH00-0XB0>, Siemens slave	[80 characters]
V4.0;	[4 characters]
B-16DO 0,5A DP;	[17 characters]
SIEMENS ;	[10 characters]
SIMATIC ;	[10 characters]
ET 200 ;	[10 characters]
ET200B/24V/DP ;	[15 characters]
00002;	[5 characters]
J;	[1 character]
J;	[1 character]
N;	[1 character]
J;	[1 character]
J;	[1 character]
J;	[1 character]
N;	[1 character]
N;	[1 character]
N;	[1 character]
N;	[1 character]
N;	[1 character]
N;	[1 character]
N;	[1 character]
N;	[1 character]
00000;	[5 characters]
1111011111;	[10 characters]
032;	[3 characters]
032;	[3 characters]
032;	[3 characters]
016;	[3 characters]
012;	[3 characters]
PV005;	[5 characters]
00;	[2 characters]
00;	[2 characters]
00;	[2 characters]
00;	[2 characters]
00;	[2 characters]
PSL000;	[6 characters]
KV000;	[5 characters]
SY;	[2 characters]
DKM000;	[6 characters]



**SI0005TD.200**

Contents of the type file for the ET 200B-16DO/2A  
(6ES7 132-0BH10-0XB0):

Type file for ET 200B-16DO/2A: SI0005TD.200	[No. of char.]
ET200B-16DO, MLFB<6ES7 132-0BH10-0XB0>, Siemens slave	[80 characters]
V4.0;	[4 characters]
B-16DO 2A DP;	[17 characters]
SIEMENS ;	[10 characters]
SIMATIC ;	[10 characters]
ET 200 ;	[10 characters]
ET200B/24V/DP ;	[15 characters]
00005;	[5 characters]
J;	[1 character]
J;	[1 character]
N;	[1 character]
J;	[1 character]
J;	[1 character]
J;	[1 character]
N;	[1 character]
N;	[1 character]
N;	[1 character]
N;	[1 character]
N;	[1 character]
N;	[1 character]
N;	[1 character]
N;	[1 character]
00000;	[5 characters]
1111011111;	[10 characters]
032;	[3 characters]
032;	[3 characters]
032;	[3 characters]
016;	[3 characters]
012;	[3 characters]
PV005;	[5 characters]
00;	[2 characters]
00;	[2 characters]
00;	[2 characters]
00;	[2 characters]
00;	[2 characters]
PSL000;	[6 characters]
KV000;	[5 characters]
SY;	[2 characters]
DKM000;	[6 characters]

## Type Files for COM ET 200 V4.x (continued)

**SI000DTD.200** Contents of the type file for the ET 200B-32DO (6ES7 132-0BL00-0XB0):

Type file for ET 200B-32DO: SI000DTD.200	[No. of char.]
ET200B-32DO, MLFB<6ES7 132-0BL00-0XB0>, Siemens slave	[80 characters]
V4.0;	[4 characters]
B-32DO DP;	[17 characters]
SIEMENS ;	[10 characters]
SIMATIC ;	[10 characters]
ET 200 ;	[10 characters]
ET200B/24V/DP ;	[15 characters]
00013;	[5 characters]
J;	[1 character]
J;	[1 character]
N;	[1 character]
J;	[1 character]
J;	[1 character]
J;	[1 character]
N;	[1 character]
N;	[1 character]
N;	[1 character]
N;	[1 character]
N;	[1 character]
N;	[1 character]
N;	[1 character]
N;	[1 character]
00000;	[5 characters]
1111011111;	[10 characters]
032;	[3 characters]
032;	[3 characters]
032;	[3 characters]
016;	[3 characters]
012;	[3 characters]
PV005;	[5 characters]
00;	[2 characters]
00;	[2 characters]
00;	[2 characters]
00;	[2 characters]
00;	[2 characters]
PSL000;	[6 characters]
KV000;	[5 characters]
SY;	[2 characters]
DKM000;	[6 characters]

**SI0003TD.200**

Contents of the type file for the ET 200B-8RO (6ES7 132-0GF00-0XB0):

Type file for ET 200B-8RO: SI0003TD.200	[No. of char.]
ET200B 8RO , MLFB<6ES7 132-0GF00-0XB0>, Siemens slave	[80 characters]
V4.0;	[4 characters]
B- 8RO DP;	[17 characters]
SIEMENS ;	[10 characters]
SIMATIC ;	[10 characters]
ET 200 ;	[10 characters]
ET200B/24V/DP ;	[15 characters]
00003;	[5 characters]
J;	[1 character]
J;	[1 character]
N;	[1 character]
J;	[1 character]
J;	[1 character]
J;	[1 character]
N;	[1 character]
N;	[1 character]
N;	[1 character]
N;	[1 character]
N;	[1 character]
N;	[1 character]
N;	[1 character]
N;	[1 character]
00000;	[5 characters]
1111011111;	[10 characters]
032;	[3 characters]
032;	[3 characters]
032;	[3 characters]
016;	[3 characters]
012;	[3 characters]
PV005;	[5 characters]
00;	[2 characters]
00;	[2 characters]
00;	[2 characters]
00;	[2 characters]
00;	[2 characters]
PSL000;	[6 characters]
KV000;	[5 characters]
SY;	[2 characters]
DKM000;	[6 characters]

## Type Files for COM ET 200 V4.x (continued)

**SI000BTD.200** Contents of the type file for the ET 200B-8DI/8DO  
(6ES7 133-0BH00-0XB0):

Type file for ET 200B-8DI/8DO: SI000BTD.200	[No. of char.]
ET200B-8DI/8DO, MLFB<6ES7 133-0BH00-0XB0>, Siemens slave	[80 characters]
V4.0;	[4 characters]
B-8DI/8DO DP;	[17 characters]
SIEMENS ;	[10 characters]
SIMATIC ;	[10 characters]
ET 200 ;	[10 characters]
ET200B/24V/DP ;	[15 characters]
00011;	[5 characters]
J;	[1 character]
J;	[1 character]
N;	[1 character]
J;	[1 character]
J;	[1 character]
J;	[1 character]
N;	[1 character]
N;	[1 character]
N;	[1 character]
N;	[1 character]
N;	[1 character]
N;	[1 character]
N;	[1 character]
N;	[1 character]
N;	[1 character]
N;	[1 character]
00000;	[5 characters]
1111011111;	[10 characters]
032;	[3 characters]
032;	[3 characters]
032;	[3 characters]
016;	[3 characters]
012;	[3 characters]
PV005;	[5 characters]
00;	[2 characters]
00;	[2 characters]
00;	[2 characters]
00;	[2 characters]
00;	[2 characters]
PSL000;	[6 characters]
KV000;	[5 characters]
SY;	[2 characters]
DKM000;	[6 characters]

**SI000FTD.200**

Contents of the type file for the ET 200B-24DI/8DO  
(6ES7 133-0BN00-0XB0):

Type file for ET 200B-24DI/8DO: SI000FTD.200	[No. of char.]
ET200B-24DI/8DO 3ms, MLFB<6ES7 133-0BN00-0XB0>, Siemens slave	[80 characters]
V4.0;	[4 characters]
B-24DI/8DO DP;	[17 characters]
SIEMENS ;	[10 characters]
SIMATIC ;	[10 characters]
ET 200 ;	[10 characters]
ET200B/24V/DP ;	[15 characters]
00015;	[5 characters]
J;	[1 character]
J;	[1 character]
N;	[1 character]
J;	[1 character]
J;	[1 character]
J;	[1 character]
N;	[1 character]
N;	[1 character]
N;	[1 character]
N;	[1 character]
N;	[1 character]
N;	[1 character]
N;	[1 character]
N;	[1 character]
00000;	[5 characters]
1111011111;	[10 characters]
032;	[3 characters]
032;	[3 characters]
032;	[3 characters]
016;	[3 characters]
012;	[3 characters]
PV005;	[5 characters]
00;	[2 characters]
00;	[2 characters]
00;	[2 characters]
00;	[2 characters]
00;	[2 characters]
PSL000;	[6 characters]
KV000;	[5 characters]
SY;	[2 characters]
DKM000;	[6 characters]

## Type Files for COM ET 200 V4.x (continued)

**SI000ETD.200** Contents of the type file for the ET 200B-24DI/8DO 0.2ms  
(6ES7 133-0BN10-0XB0):

Type file for ET 200B-24DI/8DO 0.2ms: SI000ETD.200	[No. of char.]
ET200B-24DI/8DO 0,2ms, MLFB<6ES7 133-0BN10-0XB0>, Siemens slave	[80 characters]
V4.0;	[4 characters]
B-24DI/8DO.2 DP;	[17 characters]
SIEMENS ;	[10 characters]
SIMATIC ;	[10 characters]
ET 200 ;	[10 characters]
ET200B/24V/DP ;	[15 characters]
00014;	[5 characters]
J;	[1 character]
J;	[1 character]
N;	[1 character]
J;	[1 character]
J;	[1 character]
J;	[1 character]
N;	[1 character]
N;	[1 character]
N;	[1 character]
N;	[1 character]
N;	[1 character]
N;	[1 character]
N;	[1 character]
N;	[1 character]
N;	[1 character]
N;	[1 character]
00000;	[5 characters]
1111011111;	[10 characters]
032;	[3 characters]
032;	[3 characters]
032;	[3 characters]
016;	[3 characters]
012;	[3 characters]
PV005;	[5 characters]
00;	[2 characters]
00;	[2 characters]
00;	[2 characters]
00;	[2 characters]
00;	[2 characters]
PSL000;	[6 characters]
KV000;	[5 characters]
SY;	[2 characters]
DKM000;	[6 characters]

**SI0019TD.200**

Contents of the type file for the ET 200B-16DI-AC  
(6ES7 131-0HF00-0XB0):

Type file for ET 200B-16DI-AC: SI0019TD.200	[No. of char.]
ET200B-16DI-AC, MLFB<6ES7 131-0HF00-0XB0>, Siemens slave	[80 characters]
V4.0;	[4 characters]
B-16DI-AC DP;	[17 characters]
SIEMENS ;	[10 characters]
SIMATIC ;	[10 characters]
ET 200 ;	[10 characters]
ET200B/AC ;	[15 characters]
00025;	[5 characters]
J;	[1 character]
J;	[1 character]
N;	[1 character]
J;	[1 character]
J;	[1 character]
J;	[1 character]
N;	[1 character]
N;	[1 character]
N;	[1 character]
N;	[1 character]
N;	[1 character]
N;	[1 character]
N;	[1 character]
N;	[1 character]
00000;	[5 characters]
1111011111;	[10 characters]
032;	[3 characters]
032;	[3 characters]
032;	[3 characters]
016;	[3 characters]
012;	[3 characters]
PV005;	[5 characters]
00;	[2 characters]
00;	[2 characters]
00;	[2 characters]
00;	[2 characters]
00;	[2 characters]
PSL000;	[6 characters]
KV000;	[5 characters]
SY;	[2 characters]
DKM000;	[6 characters]

## Type Files for COM ET 200 V4.x (continued)

**SI001ATD.200** Contents of the type file for the ET 200B-16DO-AC  
(6ES7 132-0HF00-0XB0):

Type file for ET 200B-16DO-AC: SI001ATD.200	[No. of char.]
ET200B-16DO-AC, MLFB<6ES7 132-0HF00-0XB0>, Siemens slave	[80 characters]
V4.0;	[4 characters]
B-16DO-AC DP;	[17 characters]
SIEMENS ;	[10 characters]
SIMATIC ;	[10 characters]
ET 200 ;	[10 characters]
ET200B/AC ;	[15 characters]
00026;	[5 characters]
J;	[1 character]
J;	[1 character]
N;	[1 character]
J;	[1 character]
J;	[1 character]
J;	[1 character]
N;	[1 character]
N;	[1 character]
N;	[1 character]
N;	[1 character]
N;	[1 character]
N;	[1 character]
N;	[1 character]
N;	[1 character]
N;	[1 character]
N;	[1 character]
00000;	[5 characters]
1111011111;	[10 characters]
032;	[3 characters]
032;	[3 characters]
032;	[3 characters]
016;	[3 characters]
012;	[3 characters]
PV005;	[5 characters]
00;	[2 characters]
00;	[2 characters]
00;	[2 characters]
00;	[2 characters]
00;	[2 characters]
PSL000;	[6 characters]
KV000;	[5 characters]
SY;	[2 characters]
DKM000;	[6 characters]



**SI001CTD.200**

Contents of the type file for the ET 200B-16RO-AC  
(6ES7 132-0HH00-0XB0):

Type file for ET 200B-16RO-AC: SI001CTD.200	[No. of char.]
ET200B-16RO-AC, MLFB<6ES7 132-0HH00-0XB0>, Siemens slave	[80 characters]
V4.0;	[4 characters]
B-16RO-AC DP;	[17 characters]
SIEMENS ;	[10 characters]
SIMATIC ;	[10 characters]
ET 200 ;	[10 characters]
ET200B/AC ;	[15 characters]
00028;	[5 characters]
J;	[1 character]
J;	[1 character]
N;	[1 character]
J;	[1 character]
J;	[1 character]
J;	[1 character]
N;	[1 character]
N;	[1 character]
N;	[1 character]
N;	[1 character]
N;	[1 character]
N;	[1 character]
N;	[1 character]
N;	[1 character]
00000;	[5 characters]
1111011111;	[10 characters]
032;	[3 characters]
032;	[3 characters]
032;	[3 characters]
016;	[3 characters]
012;	[3 characters]
PV005;	[5 characters]
00;	[2 characters]
00;	[2 characters]
00;	[2 characters]
00;	[2 characters]
00;	[2 characters]
PSL000;	[6 characters]
KV000;	[5 characters]
SY;	[2 characters]
DKM000;	[6 characters]

## Type Files for COM ET 200 V4.x (continued)

**SI001DTD.200** Contents of the type file for the ET 200B-8DI/8DO-AC  
(6ES7 133-0HH00-0XB0):

Type file for ET 200B-8DI/8RO-AC: SI001DTD.200	[No. of char.]
ET200B-8DI/8RO-AC, MLFB<6ES7 133-0HH00-0XB0>, Siemens slave	[80 characters]
V4.0;	[4 characters]
B-8DI/8RO-AC DP;	[17 characters]
SIEMENS ;	[10 characters]
SIMATIC ;	[10 characters]
ET 200 ;	[10 characters]
ET200B/AC ;	[15 characters]
00029;	[5 characters]
J;	[1 character]
J;	[1 character]
N;	[1 character]
J;	[1 character]
J;	[1 character]
J;	[1 character]
N;	[1 character]
N;	[1 character]
N;	[1 character]
N;	[1 character]
N;	[1 character]
N;	[1 character]
N;	[1 character]
N;	[1 character]
N;	[1 character]
N;	[1 character]
00000;	[5 characters]
1111011111;	[10 characters]
032;	[3 characters]
032;	[3 characters]
032;	[3 characters]
016;	[3 characters]
012;	[3 characters]
PV005;	[5 characters]
00;	[2 characters]
00;	[2 characters]
00;	[2 characters]
00;	[2 characters]
00;	[2 characters]
PSL000;	[6 characters]
KV000;	[5 characters]
SY;	[2 characters]
DKM000;	[6 characters]

**SI801ATD.200**

Contents of the type file for the ET 200B-4/8AI (6ES7 134-0KH00-0XB0):

Type file for ET 200B-4/8AI: SI801ATD.200	[No. of char.]
ET200B-4/8AI, MLFB<6ES7 134-0KH00-0XB0>, Siemens slave	[80 characters]
V4.0;	[4 characters]
B-4/8AI DP;	[17 characters]
SIEMENS ;	[10 characters]
SIMATIC ;	[10 characters]
ET200 ;	[10 characters]
ET200B/ANALOG ;	[15 characters]
32794;	[5 characters]
J;	[1 character]
J;	[1 character]
N;	[1 character]
N;	[1 character]
N;	[1 character]
J;	[1 character]
N;	[1 character]
N;	[1 character]
N;	[1 character]
N;	[1 character]
N;	[1 character]
N;	[1 character]
N;	[1 character]
N;	[1 character]
00020;	[5 characters]
0001011111;	[10 characters]
032;	[3 characters]
032;	[3 characters]
032;	[3 characters]
016;	[3 characters]
032;	[3 characters]
PV025;	[5 characters]
13;	[2 characters]
00;	[2 characters]
00;	[2 characters]
00;	[2 characters]
00;	[2 characters]
00;	[2 characters]
AA;	[2 characters]
14;	[2 characters]
14;	[2 characters]
14;	[2 characters]
14;	[2 characters]
00;	[2 characters]
00;	[2 characters]
00;	[2 characters]
00;	[2 characters]
00;	[2 characters]
00;	[2 characters]
00;	[2 characters]
00;	[2 characters]
06;	[2 characters]
FF;	[2 characters]
00;	[2 characters]

## Type Files for COM ET 200 V4.x (continued)

(Type file SI801ATD.200, continued)

00;	[ 2 characters]
00;	[ 2 characters]
00;	[ 2 characters]
PSL000;	[ 6 characters]
KV000;	[ 5 characters]
SY;	[ 2 characters]
DKM000;	[ 6 characters]

## SI8019TD.200

Contents of the type file for the ET 200B-4AI (6ES7 134-0HF00-0XB0):

Type file for ET 200B-4AI: SI8019TD.200	[No. of char.]
ET200B-4AI, MLFB<6ES7 134-0HF00-0XB0>, Siemens slave	[80 characters]
V4.0;	[4 characters]
B-4AI DP;	[17 characters]
SIEMENS ;	[10 characters]
SIMATIC ;	[10 characters]
ET200 ;	[10 characters]
ET200B/ANALOG ;	[15 characters]
32793;	[5 characters]
J;	[1 character]
J;	[1 character]
N;	[1 character]
N;	[1 character]
N;	[1 character]
J;	[1 character]
N;	[1 character]
N;	[1 character]
N;	[1 character]
N;	[1 character]
N;	[1 character]
N;	[1 character]
N;	[1 character]
00020;	[5 characters]
0001011111;	[10 characters]
032;	[3 characters]
032;	[3 characters]
032;	[3 characters]
016;	[3 characters]
032;	[3 characters]
PV025;	[5 characters]
13;	[2 characters]
00;	[2 characters]
00;	[2 characters]
00;	[2 characters]
00;	[2 characters]
00;	[2 characters]
00;	[2 characters]
19;	[2 characters]
19;	[2 characters]
19;	[2 characters]
19;	[2 characters]
00;	[2 characters]
00;	[2 characters]
00;	[2 characters]
00;	[2 characters]
00;	[2 characters]
00;	[2 characters]
00;	[2 characters]
00;	[2 characters]
06;	[2 characters]
FF;	[2 characters]
00;	[2 characters]

## Type Files for COM ET 200 V4.x (continued)

(Type file SI8019TD.200, continued)

00;	[ 2 characters]
00;	[ 2 characters]
00;	[ 2 characters]
PSL000;	[ 6 characters]
KV000;	[ 5 characters]
SY;	[ 2 characters]
DKM000;	[ 6 characters]

## SI8018TD.200

Contents of the type file for the ET 200B-4AO (6ES7 135-0HF00-0XB0):

Type file for ET 200B-4AO: SI8018TD.200	[No. of char.]
ET200B-4AO, MLFB<6ES7 135-0HF00-0XB0>, Siemens slave	[80 characters]
V4.0;	[4 characters]
B-4AO DP;	[17 characters]
SIEMENS ;	[10 characters]
SIMATIC ;	[10 characters]
ET200 ;	[10 characters]
ET200B/ANALOG ;	[15 characters]
32792;	[5 characters]
J;	[1 character]
J;	[1 character]
N;	[1 character]
N;	[1 character]
N;	[1 character]
J;	[1 character]
N;	[1 character]
N;	[1 character]
N;	[1 character]
N;	[1 character]
N;	[1 character]
N;	[1 character]
N;	[1 character]
00020;	[5 characters]
0001011111;	[10 characters]
032;	[3 characters]
032;	[3 characters]
032;	[3 characters]
016;	[3 characters]
032;	[3 characters]
PV025;	[5 characters]
13;	[2 characters]
00;	[2 characters]
00;	[2 characters]
00;	[2 characters]
00;	[2 characters]
00;	[2 characters]
00;	[2 characters]
19;	[2 characters]
19;	[2 characters]
19;	[2 characters]
19;	[2 characters]
00;	[2 characters]
00;	[2 characters]
00;	[2 characters]
00;	[2 characters]
00;	[2 characters]
00;	[2 characters]
00;	[2 characters]
00;	[2 characters]
06;	[2 characters]
FF;	[2 characters]
00;	[2 characters]

## Type Files for COM ET 200 V4.x (continued)

(Type file SI8018TD.200, continued)

00;	[ 2 characters]
00;	[ 2 characters]
00;	[ 2 characters]
PSL000;	[ 6 characters]
KV000;	[ 5 characters]
SY;	[ 2 characters]
DKM000;	[ 6 characters]



# Safety-Related Guidelines

# B

## In this Chapter

The following guidelines are designed to help you avoid injury to personnel and damage either to the product described or to connected devices.

## B.1 Active and Passive Faults in Automation Equipment

### Active and Passive Faults

Depending on the particular task for which the electronic automation equipment is used, both **active** as well as **passive** faults can result in a **dangerous** situation. For example, in drive control, an active fault is generally dangerous because it can result in an unauthorized startup of the drive. On the other hand, a passive fault in a signalling function can result in a dangerous operating state not being reported to the operator.

This differentiation of the possible faults and their classification into dangerous and non-dangerous faults, depending on the particular task, is important for all safety considerations with respect to the product supplied.



---

### Warning

In all cases where a fault in automation equipment can result in severe personal injury or substantial damage to property, i.e. where a dangerous fault can occur, additional external measures must be taken or equipment provided to ensure or enforce safe operating conditions, even in the event of a fault (e.g. by means of independent limit monitors, mechanical interlocks, etc.).

---

### Procedures for Maintenance and Repair

If measurement or testing work is to be carried out on the **ET 200B distributed I/O station**, the rules and regulations contained in the "VBG 4.0 Accident Prevention Regulations" of the German employers liability assurance association (Berufsgenossenschaft) must be observed. Particular attention is drawn to paragraph 8 "Permissible deviations when working on live parts".

Repairs to an item of automation equipment may only be carried out by **SIEMENS service personnel** or **repair shops authorized by SIEMENS** to carry out such repairs.

## B.2 Guidelines for the Planning and Installation of the Product

### Warnings

The product generally forms a part of larger systems or plants. These guidelines are intended to help integrate the product into its environment without it constituting a source of danger.



#### Warning

- Follow strictly the safety and accident prevention rules that apply in each particular case.
- In the case of equipment with a permanent power connection (stationary equipment/systems) which is not provided with an isolating switch and/or fuses which disconnect all poles, a suitable isolating switch or fuses must be provided in the building wiring system (distribution board). Furthermore, the equipment must be connected to a protective ground (PE) conductor.
- Before switching on the equipment which is operated with power system voltage, make sure that the voltage range setting on the equipment corresponds to the local power system voltage.
- In the case of equipment operating on 24 V DC, make sure that proper electrical isolation is provided between the mains supply and the 24 V supply. Only use power supply units to IEC 364-4-41 or HD 384.04.41 (VDE 0100 Part 410).
- Fluctuations or deviations of the power supply voltage from the rated value must not exceed the tolerances specified in the technical specifications. Otherwise, functional failures or dangerous conditions can occur in the electronic modules/equipment.
- Suitable measures must be taken to make sure that programs that are interrupted by a voltage dip or power supply failure resume proper operation when the power supply is restored. Care must be taken to ensure that dangerous operating conditions do not occur even momentarily. If necessary, the equipment must be forced into the "emergency stop" state.
- Emergency stop devices in accordance with EN 60204/IEC 204 (VDE 0113) must be effective in all operating modes of the automation equipment. Resetting the emergency stop device must not result in any uncontrolled or undefined restart of the equipment.
- Install the power supply and signal cables in such a manner as to prevent inductive and capacitive interference voltages from affecting the automation functions.
- Automation equipment and its operating elements must be installed in such a manner as to prevent unintentional operation.
- Automation equipment can assume an undefined state in the event of a wire break in the signal lines. To prevent this, suitable hardware and software measures must be taken when interfacing the inputs and outputs of the automation equipment.

# Glossary

## A

### **Active nodes**

Active nodes may send data to other nodes, when authorized to send, and request data from other nodes (= master station).

The IM 308-C master interface module, for example, is an active node.

## B

### **Baud rate**

Data transmission speed; specifies the number of bits transferred per second (baud rate = bit rate).

### **Bus**

Common transmission path connecting all nodes; possesses two defined ends.

### **Bus connector**

Physical connection between bus nodes and bus cable.

### **Bus node**

Device which can send, receive or amplify data over the bus, e.g. master station, slave station, programming device or ET 200 Handheld, repeater, active star coupler, etc.

### **Bus segment**

→ Segment

## C

- Chassis** Chassis defines the entire range of interconnected inactive parts of a device that are not subject to any dangerous touch voltages, even in the case of a fault.
- Coding plug** You determine the input/output circuits of the analog modules via coding plugs.
- Coding slide switch** The setting of the coding slide switch on the → terminal block determines the → electronics block that can be attached.
- Configuring** Configuring refers to address assignment for inputs/outputs of a slave station.
- Control command** A DP master can send commands to a group of slaves simultaneously for the purpose of synchronizing the slave stations.  
Event-driven synchronization of slave stations is possible using the control commands -> FREEZE and -> SYNC.
- CP 5410 S5-DOS/ST** Programming device interface for connecting SINECL2 and also SINECL2-DP. The CP5410 S5-DOS/ST can only be plugged into the PG 730, 740, 750 and 770 programming devices.
- Cyclic processing** In cyclic processing the master regularly accesses the slave station.  
The master (e.g. the IM 308-C) reads the input data of the slaves and passes on output data to the slaves.

## D

- Device-related diagnostics** Top level of slave-specific diagnostics. Device-related diagnostics refer to the entire slave.
- Diagnostics** Detection, location, classification, display and further evaluation of errors, faults and signals.  
Diagnostics offer monitoring functions which execute automatically during system operation.  
Application: enhancement of plant availability by reducing startup times and down times.

<b>DP Master</b>	→Active node which communicates with the slave stations according to a fixed algorithm and provides data for the user.
<b>DP Siemens</b>	Bus protocol developed by Siemens AG.
<b>DP Slave</b>	→DP Standard slave
<b>DP Standard</b>	Abbreviation for Draft Standard DIN 19245; Part 3.
<b>DP Standard slave</b>	→Passive node which behaves in accordance with Draft Standard DIN 19245; Part 3.
<b>E</b>	
<b>Electronics block</b>	Upper section of the ET 200B distributed I/O station. The electronics block contains the logic and is plugged into the→ terminal block.
<b>ET 200</b>	<p>Distributed I/O system for connecting distributed I/O to the S5-115U to S5-155U programmable controllers or an adequate master. ET 200 is characterized by high-speed response times since only a small amount of data (bytes) is transferred.</p> <p>ET 200 is based on the PROFIBUS Standard (DIN 19245/Part 1) and the PROFIBUS-DP Draft Standard (DIN 19245/Part 3).</p> <p>ET 200 works according to the→ master-slave access method. The master can be an IM 308-C master interface module or a host containing the CP 5480-DP.</p> <p>Slaves can be the ET 200B distributed I/O station, the ET 200C, the ET 200U or non-Siemens devices.</p>

## F

### **Floating**

In the case of floating I/O modules, the reference potentials of control and load circuits are galvanically isolated by, for example, optocouplers, relay contacts or line transformers. Input and output circuits can be grouped.

### **Floating-ground configuration**

Configuration without galvanic connection to ground. In most cases, an RC element is used to divert interference currents. (manual entitled "Guidelines for Interference – Free Installation of Stored-Program Controllers").

### **Floating-ground measurement**

With floating-ground measurement, each signal line has its own signal reference line.

Floating-ground measurement is required in the following cases:

- If the sensors are connected to different potentials and
- If different signal sources are physically apart.

## **FREEZE**

A control command from the master to the slave.

Using this control command, the master can freeze the statuses of the inputs at any given instant. The input data is then updated again only when the master sends the control command UNFREEZE.

## G

### **Ground**

Conducting ground whose potential at every point can be set to zero.

### **Ground (v.)**

To connect an electrically conducting part via a ground system to ground.

### **Ground-referenced measurement**

With ground-referenced measurement, all signal reference lines are run to a common → reference potential.

### **GSD file**

Device master data file; file in which the slave-specific characteristics such as the number of inputs or outputs, number of diagnostics bytes, SYNC capability, etc. are defined. There is a GSD file for every Siemens DP standard slave.

You only require this file if you want to connect a DP standard slave to a non-Siemens DP master. If you are using a Siemens DP master, you do not need a GSD file. The device master data for Siemens DP masters is defined in the → type file (COM ET-specific format).

**I****IP 20**

Degree of protection to DIN 40050: protection against touch and the ingress of foreign bodies with a diameter of over 12 mm Ø.

**M****Master interface module**

Module for distributed configuration. The distributed I/O is "connected" to the PLC using the IM 308-C master interface module.

**Master-slave access method**

Bus access method according to which only one node is → active at any time and all others are → passive.

**N****Non-floating**

The reference potentials of control and load circuits are electrically connected in the case of non-floating I/O modules.

**O****Overview diagnostics**

Overview diagnostics show which slave station has a diagnostics message.

**P****Parameterization master**

The master authorized to parameterize a slave station.

**Passive nodes**

Passive nodes can only exchange data with an active node after a request to do so from the active node.

Examples of passive nodes are all slaves such as ET 200B, ET 200C, etc.



**PROFIBUS** PROcess FIeld BUS, German process and field bus standard defined by the PROFIBUS standard (DIN 19245).

It specifies functional, electrical and mechanical characteristics for a bit-serial field bus system.

**PROFIBUS-DP** Draft standard PROFIBUS-DP (DIN 19245, Part 3) on which the ET 200 distributed I/O system is based.

**Protective ground conductor** A conductor required as a protection measure against electric shock currents. The symbol for the protective ground conductor is PE.

## R

**Reference potential** Potential in relation to which the voltages of the circuits concerned are observed and/or measured.

**Response time** Interval between an edge change at the input and the assigned output signal change. Response times are described in the "ET 200 Distributed I/O System" manual.

## S

**Segment** The bus cable between two terminating resistances forms a segment. A segment contains 0 to 32 → bus nodes. Segments can be linked via → repeaters.

**Short circuit** A short circuit is a fault causing a connection between conductors that are energized in normal operation if no resistance is inserted in the faulty circuit.

**SINEC L2** Bus system; networks PROFIBUS-compatible automation systems and field devices at the cell and field levels.

**SINEC L2-DP** SINEC L2 bus system with the DP protocol. DP stands for distributed I/O. ET 200 corresponds to SINEC L2-DP.

<b>Standard sectional rail</b>	<p>Standard metal section to DIN EN 50022.</p> <p>The standard sectional rail is used for fixing devices in the SIMATIC family such as the S5-95U I/O modules, the ET 200B, etc.</p>
<b>Station number</b>	<p>Each ET 200 bus node must receive a station number. The programming device is accessed with the station number "0".</p> <p>The master and slave have a station number in the range 3 to 125. Exception: the ET 200B has a station number in the range 3 to 99.</p>
<b>STOP</b>	<p>STOP is a master operating mode. Data exchange between the master and slaves does not take place.</p>
<b>SYNC</b>	<p>SYNC is a → control command issued by the master to a slave.</p> <p>Using this control command, the master can freeze the outputs at an instantaneous value. The output data for subsequent frames is stored, but the statuses of the outputs remain unchanged. The outputs are not updated again until the master sends the UNSYNC command.</p>
<b>T</b>	
<b>Terminal block</b>	<p>The terminal block carries the permanent wiring. The → electronics block is plugged into the terminal block.</p>
<b>Terminating resistance</b>	<p>Resistance for matching the impedance of bus cables; terminating resistances are always required on cable ends or segment ends.</p>
<b>Threshold monitoring time</b>	<p>This is a slave parameter in COM ET 200. If a slave station is not accessed within the threshold monitoring time, it changes to the safe state, that is, all outputs are set to "0".</p>
<b>Type file</b>	<p>File required by COM ET 200 for configuring a slave station. The slave-specific characteristics such as the number of inputs/outputs, number of diagnostics bytes, SYNC capability, etc., are defined in the type file.</p> <p>For every ET 200B station type there is a type file which is generated by Siemens, forms a component part of COM ET 200 (from Version 4.1) or is supplied with the manual.</p>

**U**

**UNFREEZE**

→FREEZE

**UNSYNC**

→SYNC

**W**

**Wire break**

This means there is a break in the lines to the sensor or a fault in the sensor itself.

# Index

## A

Active node, Glossary-1  
Address Area, 4-6  
Address ID, 4-9  
Addressing, 4-8

## B

Baud rate, Glossary-1  
Bus, Glossary-1  
Bus connector, Glossary-1  
Bus node, Glossary-1  
Bus segment, Glossary-1

## C

Changing the Fuse, 3-8  
Chassis, Glossary-2  
Code Slide Switch, 3-7  
Coding Connector, 3-7  
Coding plug, Glossary-2  
    Setting, 9-4  
Coding slideswitch, Glossary-2  
Configuration  
    Floating-ground, Glossary-4  
    Grounded, 3-13  
    Ungrounded, 3-16  
Configuring, Glossary-2  
Control command, Glossary-2  
CP 5410 S5-DOS/ST, Glossary-2  
Cyclic processing, Glossary-2

## D

Device-related diagnostics, Glossary-2  
Diagnostics, Glossary-2  
    Device-related (analog ET 200B), 6-19, 6-33  
    Device-related (digital ET 200B), 6-17, 6-31  
    Manufacturer identification, 6-29  
    Manufacturer identification, 6-15  
    Station Status, 6-12–6-14, 6-26–6-28  
Diagnostics word, 6-6  
Dismantling, 3-11

DP Master, Glossary-3  
DP Siemens, Glossary-3  
DP Slave, Glossary-3  
DP Standard, Glossary-3  
DP Standard slave, Glossary-3

## E

Electronics Block, Installing, 3-9  
Electronics block, **1-3**, 1-6, Glossary-3  
    Design, 2-4  
ET 200, Glossary-3

## F

Fault Diagnostics  
    through LEDs, 6-2  
    with COM ET 200, 6-3  
    with STEP 5, 6-5  
Floating, Glossary-4  
Floating-ground measurement, Glossary-4  
FREEZE, Glossary-4

## G

Ground, Glossary-4  
Ground (v), Glossary-4  
Grounded configuration, 3-13  
Ground-referenced measurement, Glossary-4  
GSD file, **A-1**, Glossary-4

## H

Header, 6-17, 6-19, 6-31, 6-34

## I

Individual Diagnostics, 6-17, 6-19  
Installing  
    Electronics Block, 3-9  
    Terminal block, 3-2  
IP 20, Glossary-5

## L

LEDs, 2-4, **6-2**, 6-2

## M

Manufacturer identification, 6-15, 6-29  
Master interface module, Glossary-5  
Master-Slave access method, Glossary-5  
Mounting  
    on a standard section rail, 3-4  
    with Shield Attachment, 3-5

## N

Nodes, passive, Glossary-5  
Non-floating, Glossary-5

## O

Overview diagnostics, Glossary-5

## P

Parameterization, 4-13  
Parameterization master, Glossary-5  
Parameterizing  
    ET 200B-4AI, 4-17  
    ET 200B-4AO, 4-19  
    ET 200B-4/8AI, 4-14  
Passive nodes, Glossary-5  
PROFIBUS, Glossary-6  
PROFIBUS-DP, Glossary-6  
Protective ground connector, Glossary-6

## R

Reference potential, Glossary-6  
Response time, Glossary-6

## S

Screen Form, CONFIGURING (3), 4-8  
Screen form  
    CONFIGURING (1), 4-4, 4-5  
    CONFIGURING (2), 4-6, 4-7  
    CONFIGURING (3), 4-10  
    DIAGNOSTICS, 6-3  
    DIAGNOSTICS: OVERVIEW, 6-3  
Segment, Glossary-6

Shield Connecting Element, 3-2, 3-21  
Shielding, 3-21  
Short circuit, Glossary-6  
SINEC L2, Glossary-6  
SINEC L2-DP, 1-2, Glossary-6  
Standard sectional rail, Glossary-7  
Station Diagnostics, 6-6, 6-24  
Station number, 1-5, 4-4, Glossary-7  
Station Status, 6-12–6-14, 6-26–6-28  
Station Type, 4-6  
STOP, Glossary-7  
SYNC, Glossary-7

## T

Technical specifications  
    ET 200B-16DI, 8-18  
    ET 200B-24DI/8DO, ET 200B-24DI/8DO  
        0.2ms, 8-53  
    ET 200B-32DI, ET 200B-32DI 0.2ms, 8-23  
    ET 200B-32DO, 8-38  
    ET 200B-4/8AI, 9-31  
    ET 200B-4AI, 9-49  
    ET 200B-4AO, 9-60  
    ET 200B-8DI/8DO, 8-48  
    ET 200B-16DI-AC, 8-57  
    ET 200B-16DO, 8-28  
    ET 200B-16DO/2A, 8-33  
    ET 200B-16DO-AC, 8-61  
    ET 200B-16RO-AC, 8-66  
    ET 200B-8DI/8RO-AC, 8-70  
    ET 200B-8RO, 8-43  
    General, 7-2  
Terminal block, 1-3, 1-5, Glossary-7  
    Design, 2-2  
    Installing, 3-2  
    TB1-4/DC, 8-4  
    TB1/DC, 8-4  
    TB2-4/DC, 8-12  
    TB2/DC, 8-12  
    TB3/DC, 8-4  
    TB4/DC, 8-12  
    TB6/AC, 8-12  
    TB8-analog, 9-5  
    Wiring, 3-18  
Terminating resistance, Glossary-7  
Threshold monitoring time, Glossary-7  
Type file, 4-2, **A-1**, Glossary-7

**U**

UNFREEZE, Glossary-8  
Ungrounded configuration, 3-16  
UNSYNC, Glossary-8

**W**

Wire break, Glossary-8  
Wiring, 3-18

Siemens AG  
AUT 125 Doku  
Postfach 1963  
D-92209 Amberg  
Federal Republic of Germany

From:

Your Name: .....

Your Title: .....

Company Name: .....

Street: .....

City, Zip Code: .....

Country: .....

Phone: .....

Please check any industry that applies to you:

- |  |   |
|--|---|
| <input type="checkbox"/> Automotive              | <input type="checkbox"/> Pharmaceutical |
| <input type="checkbox"/> Chemical                | <input type="checkbox"/> Plastic        |
| <input type="checkbox"/> Electrical Machinery    | <input type="checkbox"/> Pulp and Paper |
| <input type="checkbox"/> Food                    | <input type="checkbox"/> Textiles       |
| <input type="checkbox"/> Instrument and Control  | <input type="checkbox"/> Transportation |
| <input type="checkbox"/> Nonelectrical Machinery | <input type="checkbox"/> Other .....    |
| <input type="checkbox"/> Petrochemical           |   |

