



Main

Range of product	Lexium 32
Product or component type	Motion servo drive
Device short name	LXM32C
Format of the drive	Book
Network number of phases	Three phase
[Us] rated supply voltage	200...240 V (- 15...10 %) 380...480 V (- 15...10 %)
Supply voltage limits	170.0 V...264.0 V 323.0 V...528.0 V
Supply frequency	50/60 Hz (- 5...5 %)
Network frequency	47.5...63 Hz
EMC filter	Integrated
Continuous output current	21.9 A (f = 8 kHz)
Output current 3s peak	72 A for 5 s
Continuous power	6500 W at 230 V 13000 W at 400 V
Nominal power	5 kW at 230 V (f = 8 kHz) 7 kW at 400 V (f = 8 kHz)
Line current	23.5 A, THDI of 43 % at 380 V, with external line choke of 1 mH 19.5 A, THDI of 55 % at 480 V, with external line choke of 1 mH 14.6 A, THDI of 129 % at 480 V, without line choke 21.9 A, THDI of 124 % at 380 V, without line choke

Complementary

Switching frequency	8 kHz
Overvoltage category	III
Leakage current	>0.0 mA...<30.0 mA
Output voltage	<= power supply voltage
Electrical isolation	Between power and control
Type of cable	Single-strand IEC cable (for $\theta = 50^\circ\text{C}$) conductor material: copper 90°C ,wire insulation material: XLPE/EPR
Electrical connection	Terminal cable 3 mm ² AWG 12 (CN8) Terminal cable 5 mm ² AWG 10 (CN1) Terminal cable 5 mm ² AWG 10 (CN10)
Tightening torque	0.5 N.m (CN8) 0.7 N.m (CN1) 0.7 N.m (CN10)
Discrete input number	2 safety 6 logic
Discrete input type	Logic (DI) Safety (compliment of STO_A, compliment of STO_B)
Sampling duration	0.25 ms (ANA1+/ANA1-, ANA2+/ANA2-) for analog 0.25 ms (DI) for discrete
Discrete input voltage	24 V DC for logic 24 V DC for safety

The information provided in this documentation contains general descriptions and/or technical characteristics of the performance of the products contained herein. This documentation is not intended as a substitute for and is not to be used for determining suitability or reliability of these products for specific user applications. It is the duty of any such user or integrator to perform the appropriate and complete risk analysis, evaluation and testing of the products with respect to the relevant specific application or use thereof. Neither Schneider Electric Industries SAS nor any of its affiliates or subsidiaries shall be responsible or liable for misuse of the information contained herein.

Discrete input logic	Positive (compliment of STO_A, compliment of STO_B) at State 0: < 5 V at State 1: > 15 V conforming to EN/IEC 61131-2 type 1 Positive (DI) at State 0: > 19 V at State 1: < 9 V conforming to EN/IEC 61131-2 type 1 Positive or negative (DI) at State 0: < 5 V at State 1: > 15 V conforming to EN/IEC 61131-2 type 1
Response time	<= 5 ms (compliment of STO_A, compliment of STO_B)
Discrete output number	5
Discrete output type	Logic (DO) 24 V DC
Discrete output voltage	<= 30 V DC
Discrete output logic	Positive or negative (DO) conforming to EN/IEC 61131-2
Contact bounce time	<= 1 ms (compliment of STO_A, compliment of STO_B) 0.25 µs...1.5 ms (DI)
Braking current	50 mA
Analogue input number	2
Response time on output	250 µs (DO) discrete
Absolute accuracy error	< +/- 0.5 %
Linearity error	< +/- 0.1 %
Analogue input type	Analog input (ANA1+/ANA1-, ANA2+/ANA2-), differential +/- 10 V input impedance: >= 20 Ohm, resolution: 14 bits
Control signal type	Pulse train output (PTO) :RS422 (f = <= 500 kHz) (cable length: 100 m) Pulse/Direction (P/D), A/B, CW/CCW :5 V, 24 V link (open collector) (f = <= 10 kHz) (cable length: 1 m) Pulse/Direction (P/D), A/B, CW/CCW :5 V, 24 V link (push-pull) (f = <= 200 kHz) (cable length: 10 m) Pulse/Direction (P/D), A/B, CW/CCW :RS422 (f = <= 1000 kHz) (cable length: 100 m) Servo motor encoder feedback
Protection type	Against reverse polarity :inputs signal Against short-circuits :outputs signal
Safety function	STO (safe torque off), integrated
Safety level	SIL 3 conforming to EN/IEC 61508 PL = e conforming to ISO 13849-1
Communication interface	Integrated Modbus
Type of connector	RJ45 (labelled CN7) :Modbus
Physical interface	2-wire RS485 multidrop Modbus
Transmission rate	9600, 19200, 38400 bps for bus length of <= 40 m Modbus
Number of addresses	1...247 Modbus
Status LED	1 LED (red) servo drive voltage
Signalling function	Display of faults in 7 segments
Marking	CE
Operating position	Vertical +/- 10 degree
Product compatibility	Servo motor BMH (140 mm, 2 motor stacks) Servo motor BMH (140 mm, 3 motor stacks) Servo motor BMH (190 mm, 1 motor stacks) Servo motor BMH (190 mm, 2 motor stacks) Servo motor BMH (190 mm, 3 motor stacks) Servo motor BMH (205 mm, 3 motor stacks) Servo motor BSH (140 mm, 2 motor stacks) Servo motor BSH (140 mm, 3 motor stacks) Servo motor BSH (140 mm, 4 motor stacks)
Width	108 mm
Height	270 mm
Depth	237 mm
Product weight	4.8 kg
Output current 3s peak 2	72 A
Output current 3s peak 3	72 A

Environment

Electromagnetic compatibility	Conducted EMC at class A group 1 conforming to EN 55011 Conducted EMC at class A group 2 conforming to EN 55011 Conducted EMC at environment 2 category C3 conforming to EN/IEC 61800-3 Conducted EMC at category C2 conforming to EN/IEC 61800-3 Conducted EMC at environments 1 and 2 conforming to EN/IEC 61800-3 Electrostatic discharge immunity test at level 3 conforming to EN/IEC 61000-4-2 Susceptibility to electromagnetic fields at level 3 conforming to EN/IEC 61000-4-3 1.2/50 µs shock waves immunity test at level 3 conforming to EN/IEC 61000-4-5 Electrical fast transient/burst immunity test at level 4 conforming to EN/IEC 61000-4-4 Radiated EMC at class A group 2 conforming to EN 55011 Radiated EMC at category C3 conforming to EN/IEC 61800-3
Standards	EN/IEC 61800-3 EN/IEC 61800-5-1
Product certifications	CSA RoHS TÜV UL
IP degree of protection	IP20 conforming to EN/IEC 60529 IP20 conforming to EN/IEC 61800-5-1
Vibration resistance	1 gn (f = 13...150 Hz) conforming to EN/IEC 60068-2-6 1.5 mm peak to peak (f = 3...13 Hz) conforming to EN/IEC 60068-2-6
Shock resistance	15 gn for 11 ms conforming to EN/IEC 60028-2-27
Pollution degree	2 conforming to EN/IEC 61800-5-1
Environmental characteristic	Classes 3C1 conforming to IEC 60721-3-3
Relative humidity	Class 3K3 (5 to 85 %) without condensation conforming to IEC 60721-3-3
Ambient air temperature for operation	0...50 °C conforming to UL
Ambient air temperature for storage	-25.0 °C...70.0 °C
Type of cooling	Integrated fan
Operating altitude	<= 1000 m without derating > 1000...3000 m with conditions

Offer Sustainability

Sustainable offer status	Green Premium product
RoHS (date code: YYWW)	Compliant since 0930; Schneider Electric declaration of conformity
Product environmental profile	Available Download Product Environmental Product Environmental
Product end of life instructions	Available Download End Of Life Manual End Of Life Manual

RoHS compliance

RoHS EUR status	Compliant
RoHS EUR conformity date(YYWW)	0930

Lexium 32 Servo Drive

Dimensions

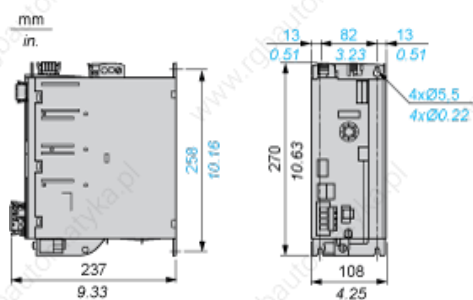

Lexium 32 Motion Control Servo Drives

Mounting Recommendations

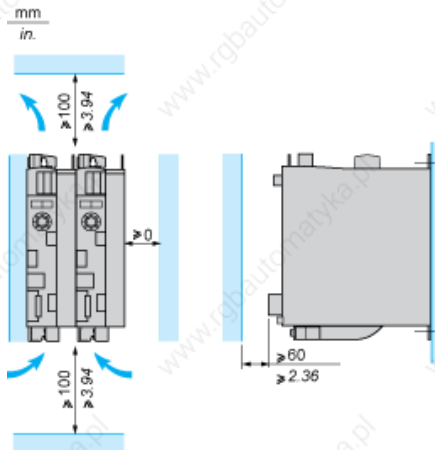

LXM32•U45M2, •U90M2 and LXM32•U60N4 servo drives are cooled by natural convection. LXM32•D18M2, •D30M2, LXM32 •D12N4, •D18N4, •D30N4 and •D72N4 servo drives have an integrated fan.

When installing the servo drive in the enclosure, follow the instructions below with regard to the temperature and protection index:

- Provide sufficient cooling of the servo drive
- Do not mount the servo drive near heat sources
- Do not mount the servo drive on flammable materials
- Do not heat the servo drive cooling air by currents of hot air from other equipment and components, for example from an external braking resistor
- Mount the servo drive vertically ($\pm 10\%$)
- If the servo drive is used above its thermal limits, control stops due to overtemperature

NOTE: For cables that are connected via the underside of the servo drive, a free space ≥ 200 mm/7.87 in. is required under the unit to comply with the bending radius of the connection cables.

Ambient temperature	Mounting distances	Instructions to be followed
0°C...+ 50°C	$d \geq 0$ mm	–
+ 50°C...+ 60°C	$d \geq 0$ mm	Reduce the output current by 2.2% per °C above 50°C

NOTE: Do not use insulated enclosures, as they have a poor level of conductivity.

Recommendations for Mounting in an Enclosure

To ensure good air circulation in the servo drive:

- Fit ventilation grilles on the enclosure.
- Ensure that ventilation is adequate, otherwise install a forced ventilation unit with a filter.

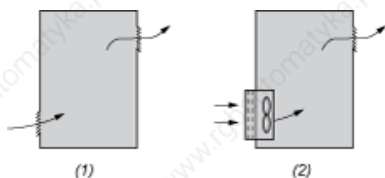

- (1) Natural convection
- (2) Forced ventilation

- Any apertures and/or fans must provide a flow rate at least equal to that of the servo drive fans (refer to characteristics).
- Use special filters with IP 54 protection.

Mounting in Metal Enclosure (IP 54 Degree of Protection)

The servo drive must be mounted in a dust and damp proof enclosure in certain environmental conditions, such as dust, corrosive gases, high humidity with risk of condensation and dripping water, splashing liquid, etc. In these cases, Lexium 32 servo drives can be installed in an enclosure where the internal temperature must not exceed 60°C.