

Magnetic rotary angle and position sensor-control

Contactless sensor PSC-360

Dimensions

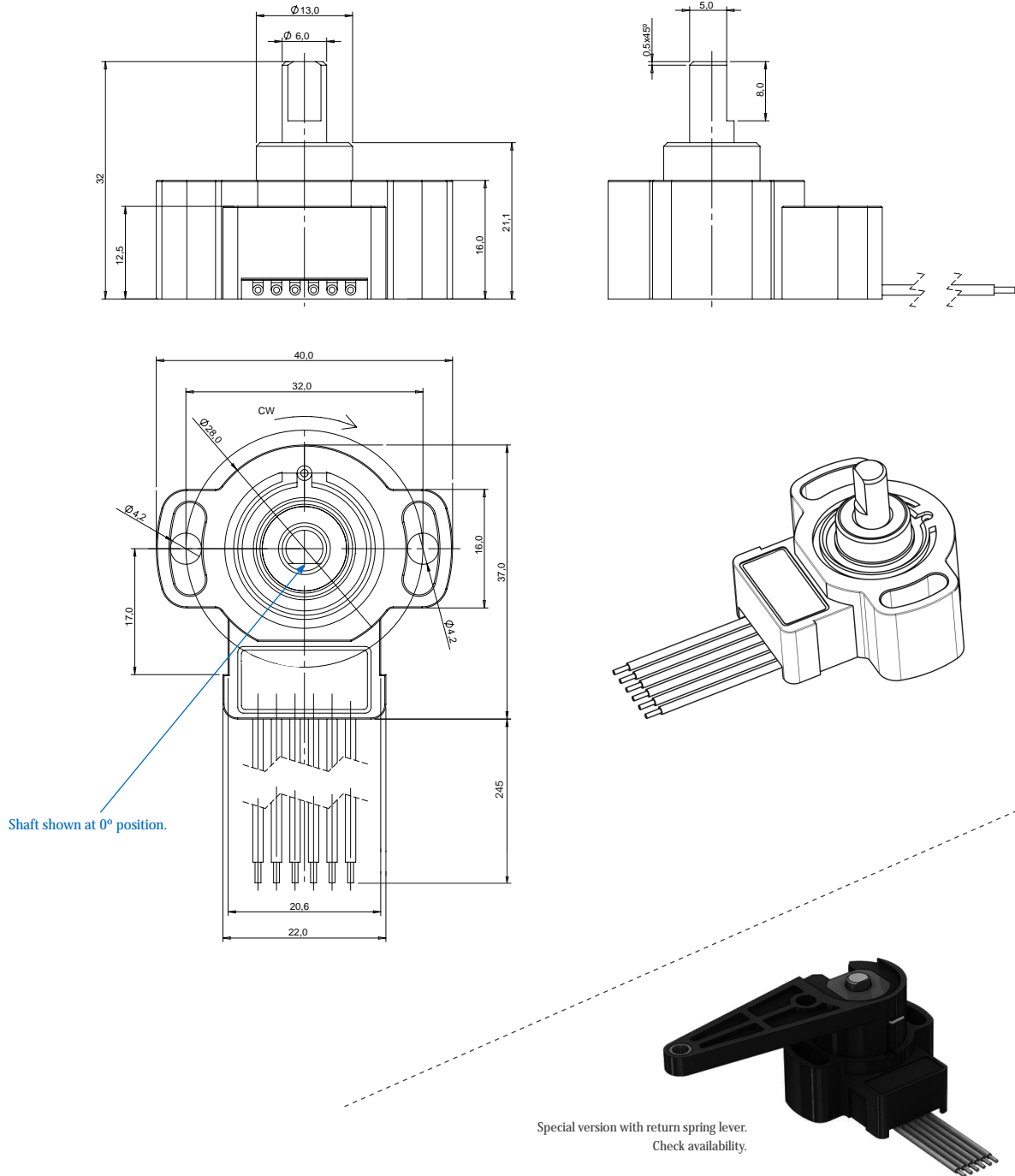

Piher Sensing Systems

Our product competencies and services:
Potentiometers | [Position / angle sensors](#) | Rotary switches | Incremental encoders
Printed circuit resistors | Mechatronics | Value added assemblies

Magnetic rotary angle and position sensor-control

Contactless sensor PSC-360

Mounting instructions

- 1.- Place the component on a flat surface.
- 2.- Fit the actuator onto the shaft avoiding any mechanical play/wobble.
- 3.- Fasten the two M4 screws (M4 washers are recommended).

Connections scheme

Simple analog output connection wiring scheme. Other versions available upon request.

- Brown = Power supply.
- Blue = Ground.
- Black = Signal output.
- White = Not used.
- Grey = Not used.

Fly leads with Wire: 0.35mm². TXL SAE J1128.
 Check availability for the connector options.

Output

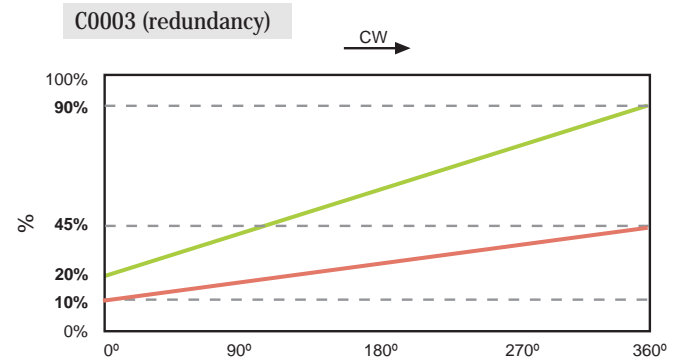
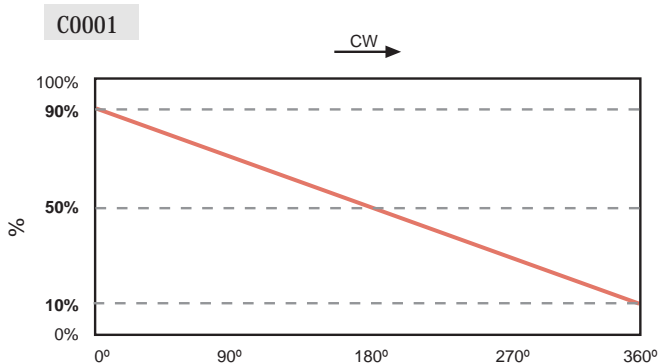
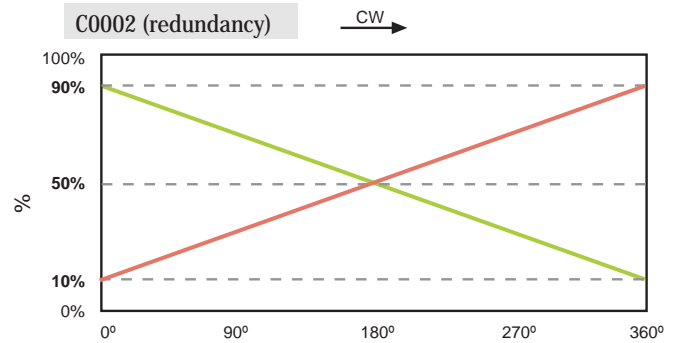
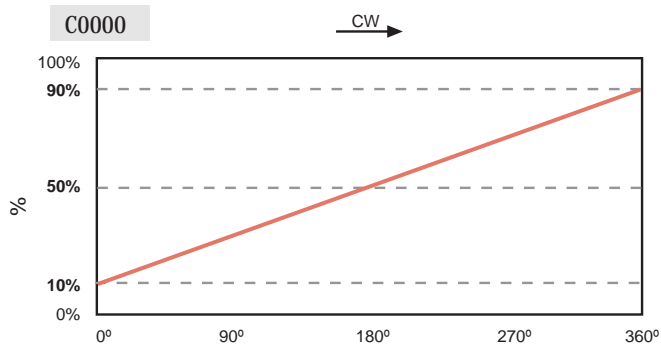

Others upon request.

Piher Sensing Systems

Our product competencies and services:
 Potentiometers | [Position / angle sensors](#) | Rotary switches | Incremental encoders
 Printed circuit resistors | Mechatronics | Value added assemblies