

rho 3

# Interface Conditions



Version

# 102



rho 3

# Interface Conditions

1070 073 025-102 (95.01) GB



Reg. Nr. 16149-03

© 1991 - 1995

by Robert Bosch GmbH,

All rights reserved, including applications for protective rights.  
Reproduction or handing over to third parties are subject to our written permission.

Discretionary charge 40.- DM

**C O N T E N T**

<b>1</b>	<b>System design</b>	
1.1	General .....	1
1.2	Card rack .....	4
1.2.1	Rack Version 1 (4 slots) .....	4
1.2.2	Rack version 2 ( 5 slots ) .....	6
1.2.3	Rack version 3 ( 19" 5/8 Slots ) .....	8
1.2.4	Rack version 4 (19" 5/7 Slots ) .....	10
1.2.5	Rackvariante 5 (6 Steckplätze) .....	12
1.2.6	Rack version 6 (8 Slots) .....	14
1.2.7	Rack VERsion 7 rho 3.2 (6 Slots) .....	16
1.2.8	Rack version 8 rho 3.2 (8 Slots) .....	18
1.2.9	rho 3 with external PLC Input/Output Cards .....	20
<b>2.</b>	<b>Dimensions, installation and interface conditions</b>	
2.1.	Dimensions – Card rack .....	21
<b>2.2.</b>	<b>Installation .....</b>	<b>25</b>
2.2.1.	Installation distances .....	26
2.3.	Card rack .....	27
2.3.1.	RC card rack 1.0 – 5 .....	27
2.3.2.	RC/PLC card rack 1.0 – 5/8 .....	28
<b>2.4.</b>	<b>Electrical connection</b>	
2.4.1.	Power supply (general) .....	34
2.4.2.	Voltages and tolerances .....	36
2.4.3.	24 V power supply for load and logic supply .....	36
2.4.4.	PE conductor, 0 V, neutral conductor, analog ground .....	37
2.4.5.	Voltage connection .....	38
2.4.6.	Interference suppression .....	40
<b>2.4.</b>	<b>Operating conditions .....</b>	<b>43</b>
<b>2.6.</b>	<b>Maintenance</b>	
2.6.1.	Control panels .....	47
2.6.2.	Card rack .....	47
2.6.3.	CP/MEM 4 module .....	48
2.6.4.	PLC modules .....	49
<b>3</b>	<b>Plug–in units</b>	
3.1	Processor/memory module CP/MEM4 .....	50
3.2	Processor/memory module CP/MEM5 .....	55
3.2.1	Input Voltage .....	56
3.2.2	Data Interfaces on CP/MEM 5 .....	57
3.2.3	Interface assignment x11,x12,x22 .....	60
<b>3.3.</b>	<b>Processor module CP 2.5 .....</b>	<b>61</b>
<b>3.4.</b>	<b>Memory module MEM 5 .....</b>	<b>68</b>



<b>3.5</b>	<b>Servo loop interface SERVO 3–5</b>	
3.5.1	Overview .....	70
3.5.2	Measuring system inputs .....	71
3.5.7	Analog setpoint outputs .....	77
3.5.8	Probe inputs / 5V probe switching voltage .....	79
3.5.8.1	Technical data, probe inputs .....	79
3.5.8.2	Pin assignment, probe inputs .....	80
3.5.8.3	Connection options for probes .....	81
<b>3.6.</b>	<b>Servo loop interface SERVO 8</b>	
3.6.1.	Overview .....	82
3.6.2.	Measuring system inputs .....	83
3.6.4.	Analog setpoint outputs .....	90
<b>3.7.</b>	<b>Servo card modular SERVO .....</b>	<b>95</b>
3.7.1.	Overview of modular Servo abs8 .....	96
3.7.2.	Overview of modular Servo abs7/inc1 .....	97
3.7.3.	Overview of modular Servo abs5 .....	98
3.7.4.	Overview of modular Servo inc6/poti1 .....	99
3.7.5.	Incremental measuring system inputs .....	100
3.7.5.1.	Approved incremental digital measuring .....	101
3.7.5.2.	Pin assignments of incremental measuring systems .....	103
3.7.6.	Absolute encoder module .....	106
3.7.6.1.	Pin assignment for absolute encoder module .....	107
3.7.7.	Potentiometer measuring system module .....	108
3.7.7.1.	Pin assignment for potentiometer module .....	109
3.7.8.	Analog setpoint outputs .....	111
3.7.8.1.	Pin assignment OUT ANALOG X22 .....	112
<b>3.8</b>	<b>Control Loop Card Modular SERVO m.i. ....</b>	<b>113</b>
3.8.1	Identification of connections .....	114
3.8.2	Overview of SERVO m.i. ABS3 .....	115
3.8.3	Overview of SERVO m.i. ABS4/INC1 .....	116
3.8.4	Overview of SERVO m.i. ABS6/INC1 .....	117
3.8.5	Overview of SERVO m.i. ABS8/INC1 .....	118
3.8.6	Overview of SERVO m.i. ABS9 .....	119
3.8.7	Overview of SERVO m.i. ABS6/INC1/Potentiometer .....	120
3.8.8	Incremental measuring system inputs .....	121
3.8.8.1	Permissible incremental measuring systems .....	121
3.8.8.2	Rotary measuring systems .....	123
3.8.8.3	Linear measuring systems .....	123
3.8.8.4	Recommended pulse shaper electronics (EXE) .....	124
3.8.8.5	Connection assignment for incremental measuring systems .....	125
3.8.8.6	Cable Servo measuring system (ROD) .....	128
3.8.9	Absolute encoder module .....	129
3.8.9.1	Interface characteristics of absolute measuring systems ..	129
3.8.9.2	Permissible absolute measuring systems .....	130
3.8.9.3	Pin assignment for absolute encoder module .....	132
3.8.10	Potentiometer measuring system module .....	133
3.8.10.1	Pin assignment for potentiometer module .....	134
3.8.11	Analog setpoint outputs .....	136



3.8.11.1	Pin assignment analog outputs .....	137
3.8.12	Fast inputs .....	138
3.8.12.1	Technical data, fast inputs .....	138
3.8.12.2	Pin assignment, fast inputs .....	139
3.8.13	Probe inputs / 5V probe switching voltage .....	140
3.8.13.1	Technical data, probe inputs .....	140
3.8.13.2	Pin assignment, probe inputs .....	141
3.8.13.3	Connection options for probes .....	142
<b>3.9.</b>	<b>Servo interface SERVO i</b>	
3.9.1.	Overview .....	143
3.9.2.	Measuring system inputs .....	145
3.9.3.	Analog setpoint outputs .....	153
3.9.4.	Fast inputs .....	155
3.9.4.1.	Technical data, fast inputs .....	155
3.9.4.2.	Pin assignment, fast inputs .....	156
3.9.5.	Probe inputs / 5V probe switching voltage .....	157
3.9.5.1.	Technical data, probe inputs .....	157
3.9.5.2.	Pin assignment, probe inputs .....	158
3.9.5.3.	Connection options for probes .....	159
<b>3.10</b>	<b>Modulo I/O 24/0.1 with PIC250 .....</b>	<b>160</b>
<b>3.11</b>	<b>Input/Output Module I/O-32/16 0.5-A .....</b>	<b>166</b>
3.11.1	Power Supply .....	167
3.11.3	Outputs .....	168
3.11.4	Generating and Applying the 24 Volts .....	169
3.11.5	Extensions .....	170
<b>3.12</b>	<b>Module NC-PLC-I/O .....</b>	<b>172</b>
<b>3.13</b>	<b>Module NC-PLC-Bit (Bit Coupler) .....</b>	<b>175</b>
3.13.1	Connection cable NC-PLC-Bit to AG/Z or AG/P .....	176
3.13.2	Connection cable NC-PLC-Bit to AG/Z-S or AG/P-S. ....	177
<b>3.14</b>	<b>Power supply PS 75 .....</b>	<b>178</b>
<b>3.15</b>	<b>Module PS 200 (power supply) .....</b>	<b>180</b>
<b>4</b>	<b>Programmable manipulator PHG 3</b>	
4.1	Construction .....	183
4.2	Environmental conditions .....	184
4.3	Keypad .....	184
4.4	Display .....	184
4.5	Emergency stop .....	184
4.6	Confirmation key .....	184
4.7	Cable and Connector .....	185
4.8	Interface .....	185
4.9	Adaptor cable .....	186
4.10	Extension cable for the PHG .....	187

## 1 System design

### 1.1 General

GeneralThe rho 3 a modular design, i.e. different function areas such as processor, memory, servo loops etc. are located on separate plug-in units.

The card rack accommodates all the plugged-in modules required. It combines the individual modules to produce an electrical and mechanical unit (**logic unit**).

The control rho3 is available with two different processor concepts:

the **rho 3.1**, where the CPU and memory are located in one module (see plug-in unit CP/MEM 4 CP/MEM 5),

the **rho 3.2**, where the CPU and memory are located on separate modules (see plug-in units CP2.5 and MEM5)

In addition to the logic unit, the control system may also include the following elements:

- Programming system**
- Handheld programmer**
- Handling system/robot**
- external PLC**

**Online/Offline programming system Hand-held programmer**

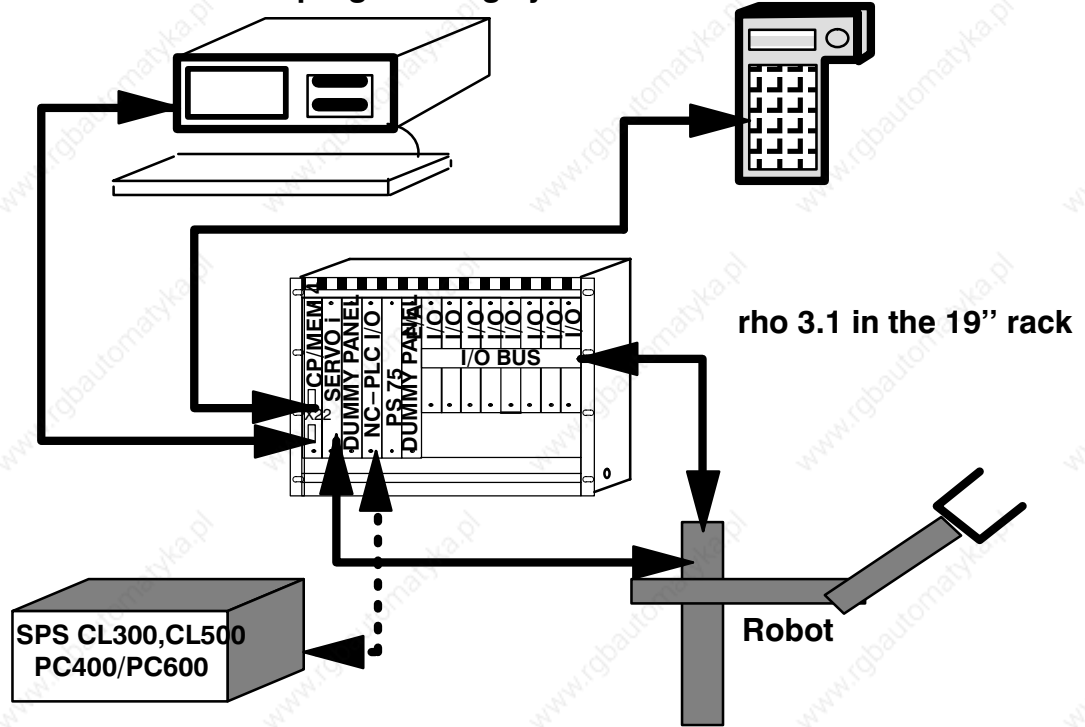

**Example: RC card rack**  
equipped with CP/MEM4, Servo i,  
I/O 24/0.1 and PS 75

**Example: RC/PLC I/O card rack**  
equipped with CP/MEM4, Servo i, NC-PLC  
I/O, PS 75 and I/O cards

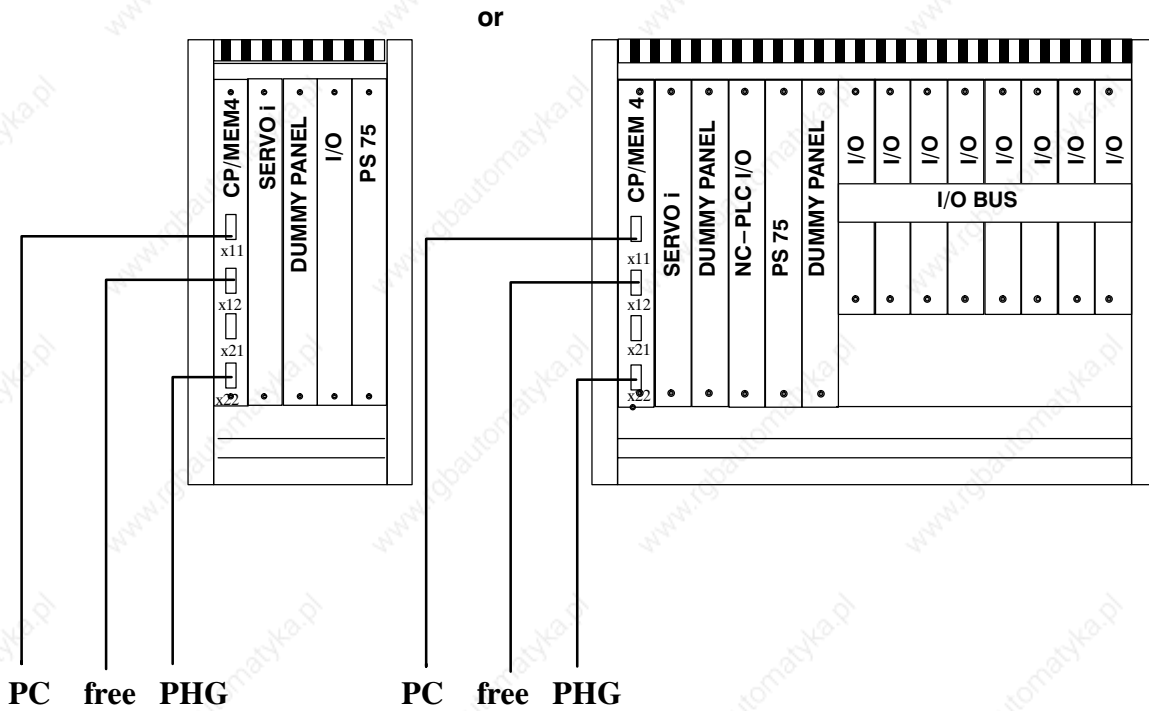

**System design rho 3.1 (schematic)**



**1.2 Card rack**

The rho 3.1 is available in the following versions 1 through 6, and the rho 3.2 in the version 7 and 8.

**1.2.1 RACK VERSION 1 (4 SLOTS)**



**Version table for  
rack version 1**

Card \ Rack slot	RACK 1.0 – 4			
	201	202	203	204
<b>CP/MEM5 up to 512 kB</b>				
<b>I/O 32/24 with PIC + CAN</b>				
I/O 64/40 with PIC + CAN				
I/O 32/16 with PIC + CAN				
NC – PLC (B) with CAN				
PC – IO with PIC + CAN				
SERVO 3 narrow				
SERVO 5 narrow				
SERVO 4i				
SERVO 6i				
SERVO ABS 3i				
I/O 32/24				
I/O 64/40				
I/O 32/16				
I/O 32/16 with PIC				
I/O 32/24 with PIC				
I/O 64/40 with PIC				
NC – PLC (B)				
PC – IO with PIC 250				
<b>PS 75</b>				



Card can be inserted in this slot and occupies one slot.

**1.2.2 RACK VERSION 2 ( 5 SLOTS )**

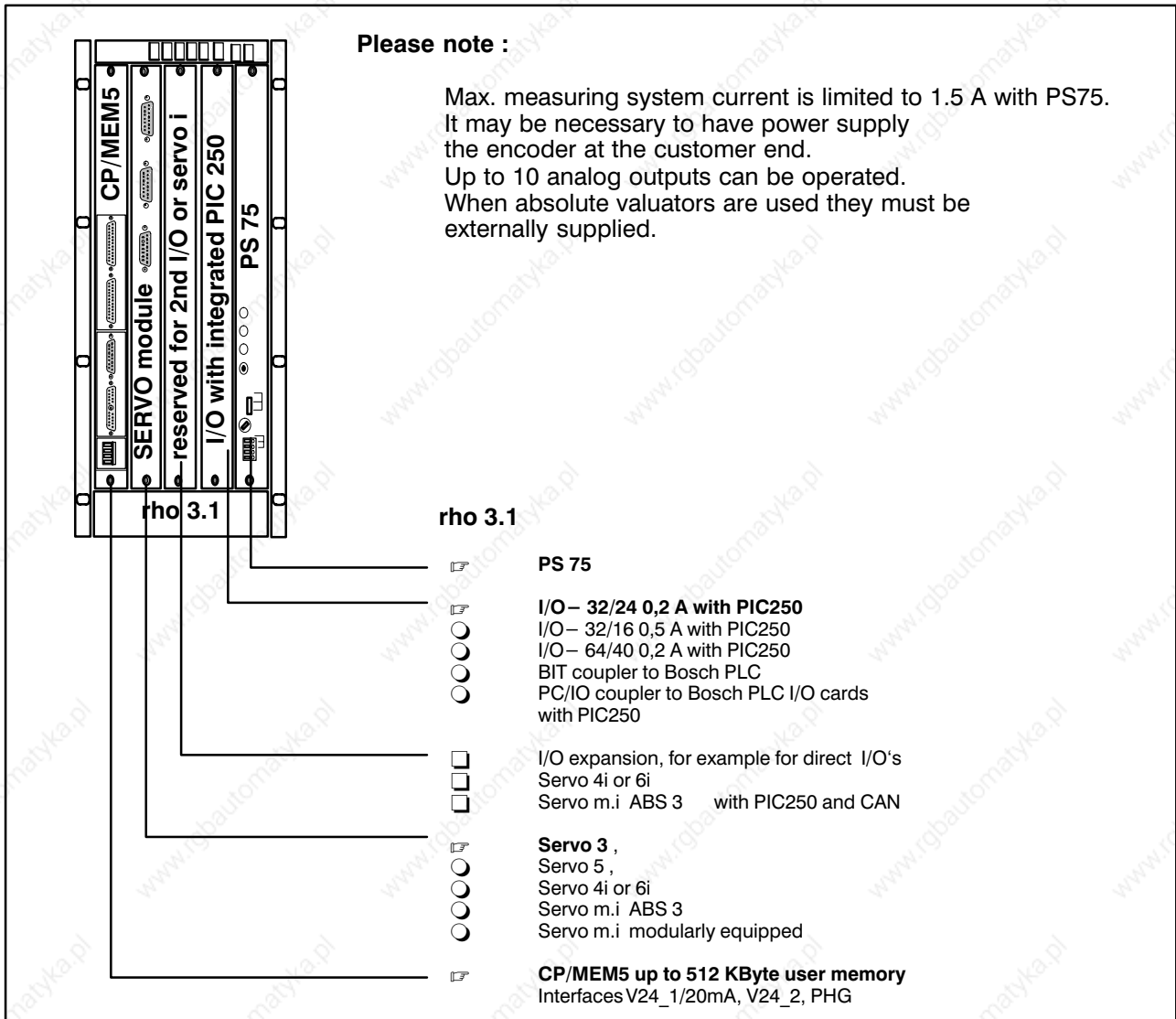

Card \ Rack slot	RACK 1.0 – 5				
	201	202	203	204	205
<b>CP/MEM 5 until 512kB</b>					
<b>SERVO 3 narrow</b>					
SERVO 5 narrow					
SERVO8 wide					
SERVO 4iS					
SERVO 6iS					
SERVO ABS 3i					
SERVO m.i.ABS4/INC1					
SERVO m.i.ABS6/INC1					
SERVO m.i.ABS8/INC1					
SERVO m.i.ABS9					
I/O 32/24 0,2A 24V DC					
I/O 64/40 0,2A 24V DC					
I/O 32/16 0,5A 24V DC					
I/O 32/16 with PIC					
<b>I/O 32/24 with PIC</b>					
I/O 64/40 with PIC					
I/O 32/24 with PIC + CAN					
I/O 64/40 with PIC + CAN					
I/O 32/16 with PIC + CAN					
NC – PLC (B)					
NC – PLC (B) with CAN					
PC – IO with PIC + CAN					
PC – IO with PIC 250					
<b>PS 75</b>					

**Version table for rack version 2**



Card can be inserted in this slot and occupies one slot.



Card occupies two slots

**1.2.3 RACK VERSION 3 ( 19" 5/8 SLOTS )**



Rack slot Card	RACK NC 5/8 19" with PC – IO													
	201	202	203	204	205	206	1	2	3	4	5	6	7	8
<b>CP/MEM 5 512kB</b>														
<b>SERVO 3 narrow</b>														
SERVO 5 narrow														
SERVO8 wide														
SERVO 4iS														
SERVO 6iS														
SERVO ABS 3i														
SERVO m.i.ABS4/INC1														
SERVO m.i.ABS6/INC1														
SERVO m.i.ABS8/INC1														
SERVO m.i.ABS9														
I/O 32/24														
I/O 64/40														
I/O 32/16														
I/O 32/16 with PIC														
I/O 32/24 with PIC														
I/O 64/40 with PIC														
I/O 64/40 with PIC + CAN														
I/O 32/16 with PIC + CAN														
NC – PLC (B)														
NC – PLC (B) with CAN														
PC – IO with PIC + CAN														
<b>PC – IO with PIC 250</b>														
<b>PS 75</b>														
PS 200 *)														
PLC I/O card														

 Card can be inserted in this slot and occupies one slot

 Card occupies two slots

\*) PS200 for configurations with more than 1.5 A measuring system current and/or when operating more than 10 analog outputs.

**1.2.4 RACK VERSION 4 (19" 5/7 SLOTS )**



Rack slot Card	RACK NC/CL 5/7 19"with Bitkoppler														
								202	203	204	205	206	207	208	209
<b>CP/MEM5 512kB</b>	■														
<b>SERVO 3 narrow</b>		■													
SERVO 5 narrow			■												
SERVO8 wide				■											
SERVO 4iS					■										
SERVO 6iS						■									
SERVO ABS 3i							■								
SERVO m.i. ABS4/INC1					■										
SERVO m.i. ABS6/INC1						■									
SERVO m.i. ABS8/INC1							■								
SERVO m.i.ABS6/INC1/PO								■							
SERVO m.i. ABS9									■						
I/O 32/24										■					
I/O 64/40											■				
I/O 32/16												■			
I/O 32/16 with PIC													■		
I/O 32/24 with PIC														■	
I/O 64/40 with PIC															■
I/O 64/40 with PIC + CAN															
I/O 32/16 with PIC + CAN															
NC – PLC (B)															
NC – PLC (B) with CAN															
PC – IO with PIC + CAN															
PC – IO with PIC 250															
<b>PS 75</b>															
PS 200 *)															
<b>NT1</b>															
<b>ZE300</b>															
PLC I/O card															

■ Cards can be inserted in this slot and occupies one slot

■ Card occupies two slots

\*) PS200 for configurations with more than 1.5 A measuring system current and/or when operating more than 10 analog outputs.



**1.2.5 RACKVARIANTE 5 (6 STECKPLÄTZE)**

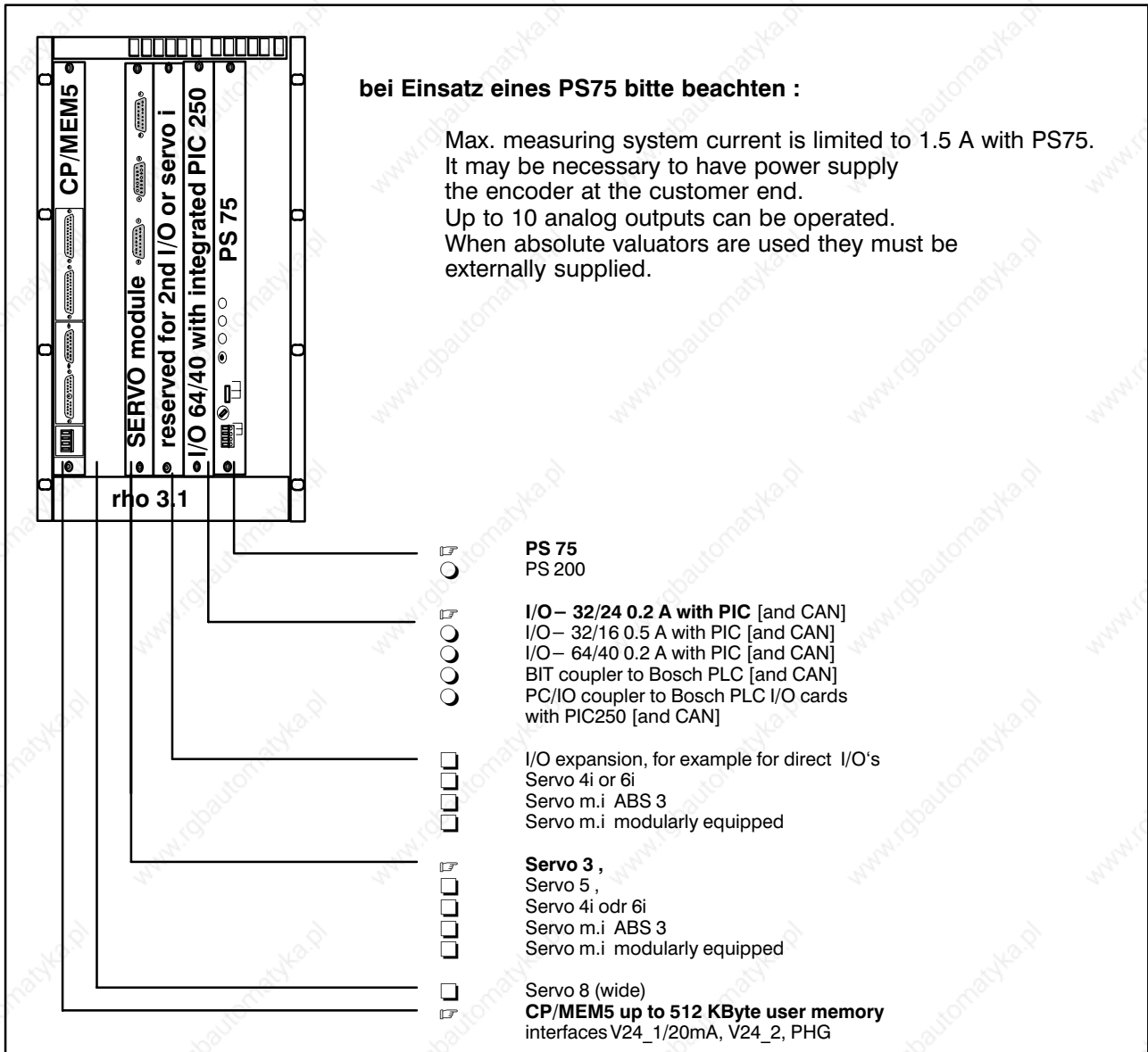

Rack slot Card	RACK 2.5 – 6						
	201	202	203	204	205	206	207
<b>CP/MEM 5 up to 512kB</b>							
<b>SERVO 3 narrow</b>							
SERVO 5 narrow							
SERVO 8 wide							
SERVO 4iS							
SERVO 6iS							
SERVO ABS 3i							
SERVO m.i. ABS4/INC1							
SERVO m.i. ABS6/INC1							
SERVO m.i. ABS8/INC1							
SERVO m.i. ABS6/INC/POT							
SERVO m.i. ABS9							
I/O 32/24							
I/O 64/40							
I/O 32/16							
<b>I/O 32/16 with PIC</b>							
I/O 32/24 with PIC							
I/O 64/40 with PIC							
I/O 32/24 with PIC + CAN							
I/O 64/40 with PIC + CAN							
I/O 32/16 with PIC + CAN							
NC – PLC (B)							
NC – PLC (B) with CAN							
PC – IO with PIC + CAN							
PC – IO with PIC 250							
<b>PS 75</b>							
<b>PS 200 *)</b>							

**Version table  
for rack 5**

 Card can be inserted in this slot and occupies one slot

 Card occupies two slots

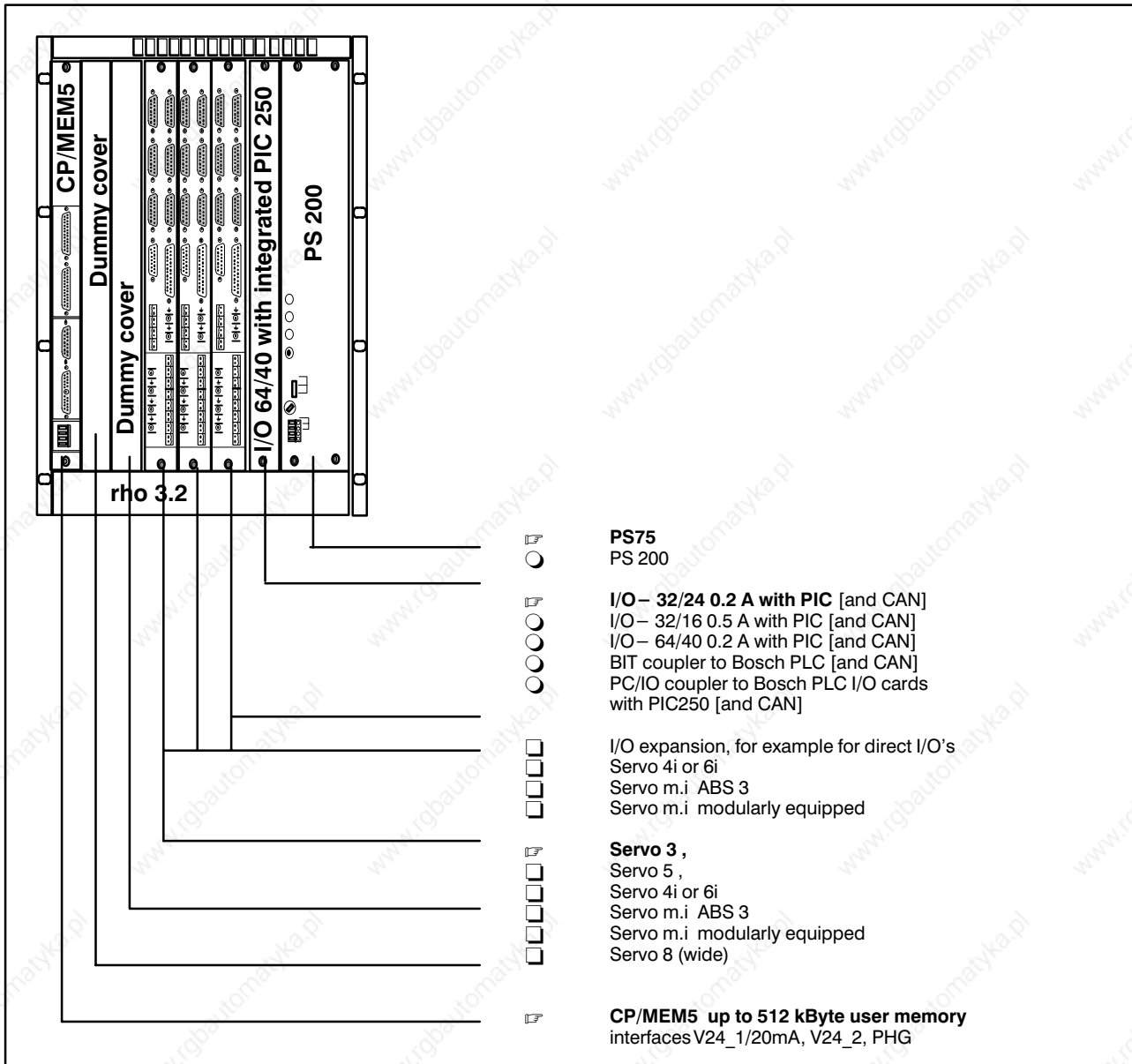

\*) PS200 for configurations with more than 1.5 A measuring system current and/or when operating more than 10 analog outputs.

**1.2.6 RACK VERSION 6 (8 SLOTS)**



Rack slot Card	RACK 2.5 – 8								
	201	202	203	204	205	206	207	208	209
<b>CP/MEM 5 up to 512kB</b>									
<b>SERVO 3 narrow</b>									
SERVO 5 narrow									
SERVO8 wide									
SERVO 4iS									
SERVO 6iS									
SERVO ABS 3i									
SERVO m.i.ABS4/INC1									
SERVO m.i.ABS6/INC1									
SERVO m.i.ABS8/INC1									
SERVO m.i.ABS6/INC1/PO									
SERVO m.i.ABS9									
I/O 32/24									
I/O 64/40									
I/O 32/16									
I/O 32/16 with PIC									
<b>I/O 32/24 with PIC</b>									
I/O 64/40 with PIC									
I/O 32/24 with PIC + CAN									
I/O 64/40 with PIC + CAN									
I/O 32/16 with PIC + CAN									
NC – PLC (B)									
NC – PLC (B) with CAN									
PC – IO with PIC + CAN									
PC – IO with PIC 250									
<b>PS 75</b>									
PS 200 *)									

**Version table  
for rack version 6**

-  Card can be inserted in this slot and occupies one slot
-  Card occupies two slots

\*) PS200 for configurations with more than 1.5 A measuring system current and/or when operating more than 10 analog outputs.

**1.2.7 RACK VERSION 7 RHO 3.2 (6 SLOTS)**

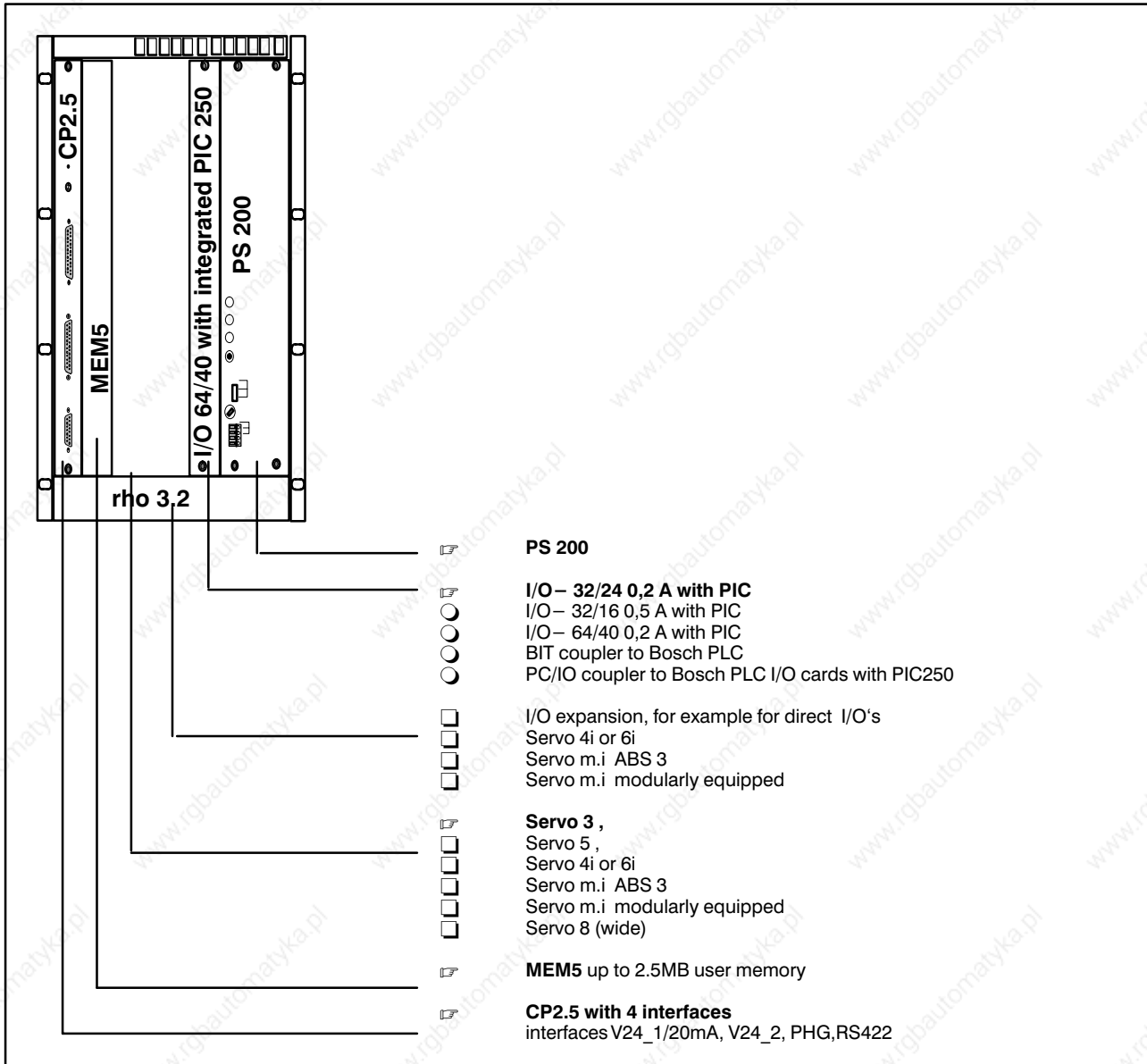

- **CP2.5** processor card with 2 CPU/FPU – cards15 MHz  
serial interface  
Interface RS 232/20mA for connecting  
the Offline programming system  
Serial interface for connecting the PHG  
2 free serial interfaces (RS232/20mA)  
1 free serial interface (RS 422)
- **MEM5** Memory with 128 KBYTE user memory  
expandable to 2.5 MB
- **SERVO 3** Control and evaluation for 3 axes  
incremental, measuring probe input
- **I/O 32/24 0,2A** with intergrated PLC PIC250  
4k program step EEPROM
- **PS200** power supply

Rack slot Card	RACK 2.5 – 6						
	201	202	203	204	205	206	207
CP2.5							
MEM5 bis 2,5 MB							
SERVO 3 narrow							
SERVO 5 narrow							
SERVO8 wide							
SERVO 4iS							
SERVO 6iS							
SERVO ABS 3i							
SERVO m.i.ABS4/INC1							
SERVO m.i.ABS6/INC1							
SERVO m.i.ABS8/INC1							
SERVO m.i.ABS6/INC1/PO							
SERVO m.i.ABS9							
I/O 32/24							
I/O 64/40							
I/O 32/16							
I/O 32/16 with PIC							
I/O 32/24 with PIC							
I/O 64/40 with PIC							
PC – IO with PIC 250							
NC – PLC (B)							
PS 200							

Version table  
for rack version 7



Card can be inserted in this slot and occupies one slot.



Card can be inserted in this slot and occupies one slot.

**1.2.8 RACK VERSION 8 RHO 3.2 (8 SLOTS)**



Rack slot Card	RACK 2.5 – 8								
	201	202	203	204	205	206	207	208	209
CP2.5	■								
MEM5 up to 2.5 MB		■							
SERVO 3 narrow				■					
SERVO 5 narrow				■					
SERVO8 wide			■	■					
SERVO 4iS				■		■			
SERVO 6iS				■		■			
SERVO ABS 3i				■	■	■			
SERVO m.i.ABS4/INC1			■	■	■	■			
SERVO m.i.ABS6/INC1			■	■	■	■			
SERVO m.i.ABS8/INC1			■	■	■	■			
SERVO m.i.ABS6/INC1/POT			■	■	■	■			
SERVO m.i.ABS9			■	■	■	■			
I/O 32/24						■			
I/O 64/40						■			
I/O 32/16						■			
I/O 32/16 with PIC							■		
I/O 32/24 with PIC							■		
I/O 64/40 with PIC							■		
PC – IO with PIC 250							■		
NC – PLC (B)							■		
PS 200									■

**Version table**  
**for rack version 8**



Card can be inserted in this slot and occupies one slot.



Card can be inserted in this slot and occupies two slots.



**1.2.9 rho 3 with external PLC Input/Output Cards**



## 2. Dimensions, installation and interface conditions

### 2.1. Dimensions – Card rack



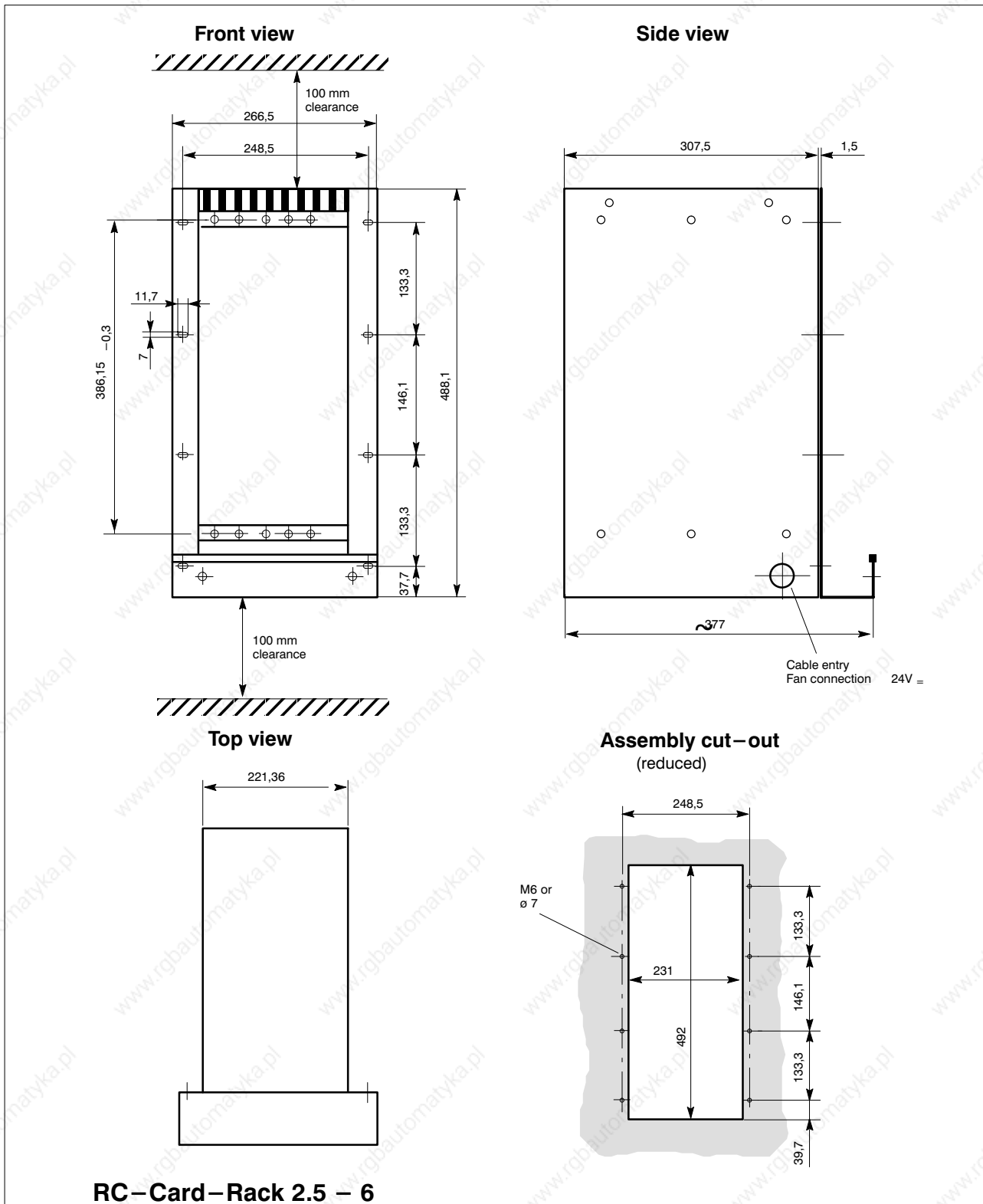



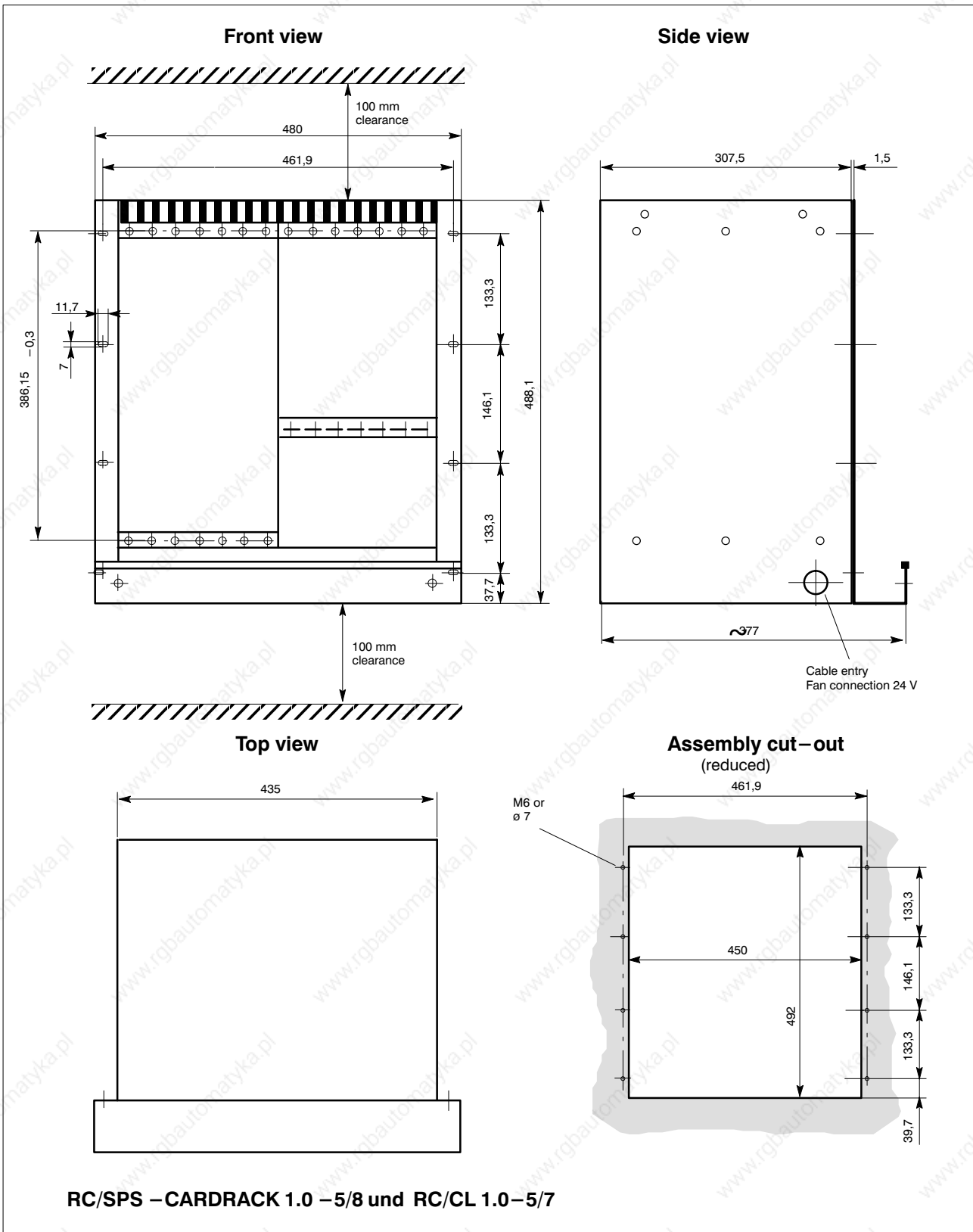

## 2.2. Installation

The RC logic unit can be mounted on the **front or rear side**. The assembly kit order No. 050409 (bracket + screws) is required for rear mounting.

**Installation Position** : Vertical. Make sure that there is a clearance on all sides of 100 mm and a clearance of 5 mm from the rear wall for ventilation purposes.

**Type of installation**: Control cabinet installation in accordance with IP 54.

### Rear installation



### Hole pattern for rear installation



### 2.2.1. Installation distances

The individual RC and PLC card racks require certain clearances for ventilation and cable routing.

- In the RC card rack, the **minimum clearance** is 100 mm. Cable ducts may be located in this clearance.

- The **maximum distance** between the RC and PLC card racks is restricted by their connecting cables (refer to the system description PC 60, P. No. 3594, for information on distance and design of the PLC modules themselves). Cable lengths for bit coupling between RC and PLC:

Cable NC–PLC–bit to AG/Z or AG/P: 0.55m  
(Order No. 041535)

Cable NC–PLC–bit to AG/P: 1.8m  
(Order No. 048081)

Cable length for word coupling between RC and PLC:

Cable NC–PLC–Word to AG/NC3: 0.7m  
(Order No. 060742)

Cable NC–PLC–Word to AG/NC3: 1.5 m  
(Order No. 060743).

Recommended installation of RC and PLC card racks:

Install PLC rack flush right above RC rack. Vertical distance between the two racks 100 mm.

- The **distances from sources of interference** (transformers, reactors, drive amplifiers, power contactors etc.) must be as large as possible. If necessary, sources of interference must be partitioned off by screen plates.

### 2.3. Card rack

Two different card rack versions are available for the rho 3.1:

- RC card rack 1.0–5 (RC logic unit with max. 5 plug-in units).
- RC/PLC card rack 1.0–5/8 (RC–PLC I/O logic unit with max. 5 plug-in units and 8 PLC modules).

#### 2.3.1. RC card rack 1.0 – 5

The housing is designed to accommodate a maximum of 5 plug-units. The plug-in fan unit underneath the card is operated with 24 V<sub>DC</sub>.

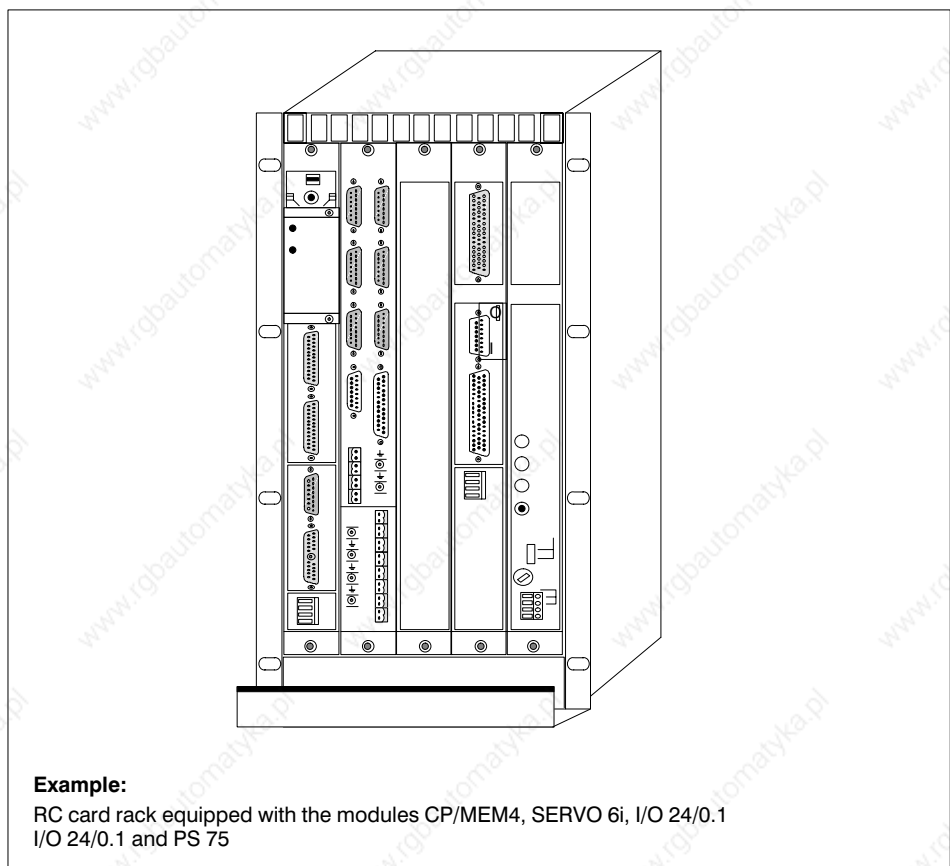



**2.3.2. RC/PLC card rack 1.0 – 5/8**

The rho 3.1 section is extended here by a rack section for PLC I/O modules. A total of 8 slots are available for PLC modules.

The fan underneath the PLC cards (24 V DC) is already prewired with the plug-in fan unit.



**1.2.3 Equipment variants**

The card rack (rho 3.1 section) is prepared for the following rho cards. The respective figures schematically show the equipment possibilities for the RC card rack 1.0–5 and the RC/PLC card rack 1.0–5/8.

- CP/MEM4, processor/memory module**
  - Max. 512 kByte RAM (user memory)
  - Max. 64 kByte EEPROM
- Servo modules**
  - Servo3
  - Servo5
  - Servo8
  - Servo3i, Servo4i, Servo6i – these cards may be installed twice
  - Modular servo for connection of up to 8 axes with different measuring systems
- Power supply PS 75**
  - The power supply supplies the internal voltages for the logic circuits of all plug-in units.

**rho 3.1 Logic unit**

	1.		5.		Slot
		CP/ MEM4	SERVO 3i	Dummy- Panel	I/O 24/0.1
			SERVO 4i	Second I/O	NC-PLC BIT
			SERVO 6i	SERVO 3i	PS 75
				SERVO 4i	
				SCP2	NC-PLC I/O

\*) only on CC 220 M

**Slots 1 and 5**

Slots **1** and **5** are reserved for the modules CP/MEM4 and PS75 in **both** card racks.

In the **RC/PLC card rack**, slot **6** is always additionally equipped with a dummy panel.

**rho 3.1-PLC I/O logic  
unit**

	1.	2	3	4	5	6	Slot							
CP/ MEM4	SERVO 3i	DUMMY PANEL	Second I/O	NC-PLC I/O	PS 75	DUMMY PANEL	I/O	I/O	I/O	I/O	I/O	I/O	I/O	I/O
	SERVO 4i	SERVO 3i												
		SERVO 4i												
	SERVO 6i	SCP2			PS 200									

○ **Servo variants, servo loop modules (servo cards)**

- Servo 3i with 3 incremental measuring system inputs and 3 analog setpoint outputs.
- Servo 4i with 4 incremental measuring system inputs and 4 analog setpoint outputs
- Servo 6i with 6 incremental measuring system inputs and 7 analog setpoint outputs
- A maximum of 2 servo i cards can be installed.

**rho 3.1 – Logic unit**

		2.	3.	Slot	
CP/ MEM4	SERVO 3i	DUMMY PANEL	I/O 24/0.1	PS 75	
		Second I/O	NC-PLC BIT		
	SERVO 4i	SERVO 3i	NC-PLC WORD*)		
		SERVO 4i	NC-PLC I/O		
	SERVO 6i	SCP2			

\*) Only on CC 220 M

**Slot 3**

Slot 3 can be alternatively used for a second servo card (Servo 3i, Servo 4i), a **second** I/O card or one SPC2 card. The cards installed in slots 2 and 4 are decisive here. A dummy panel is fitted instead of a second servo or I/O card or the SPC card.

**Slot 2**

Slot 2 is intended for one Servo i card in both card rack versions (Servo 6i, Servo 4i, Servo 3i).

**rho 3.1 – PLC I/O Logic unit**

		1.	2	3	4	5	6	Slot					
CP/ MEM4	SERVO 3i	DUMMY PANEL	NC-PLC I/O	PS 75	DUMMY PANEL	I/O	I/O	I/O	I/O	I/O	I/O	I/O	I/O
		Second I/O											
	SERVO 4i	SERVO 3i	PS 200										
		SERVO 4i											
	SERVO 6i	SCP2											

**Slot 3**

Slot 3 can be alternatively used for a second Servo i card (Servo 3i, Servo 4i) or a dummy panel.

○ **PLC-variants**

- I/O 24/0.1 with PIC 250  
I/O card with 64 inputs and 40 outputs and internal PLC (PIC 250).  
Installation of a second I/O card (without PIC 250) is possible.
- Bit coupling  
RC-PLC bit coupler, interface module to external PLC (PC600, CL300).
- RC-PLC I/O coupling  
Direct coupling with PLC I/O cards which are accommodated in the combined rack or an external rack.

**rho 3.1-Logic unit**

		3.	4.	Slot
CP/ MEM4	SERVO 3i	DUMMY PANEL	I/O 24/0.1	PS 75
	SERVO 4i	Second I/O	NC-PLC BIT	
	SERVO 6i	SERVO 3i	NC-PLC WORD*)	
		SERVO 4i	NC-PLC I/O	
		SCP2		

\*) Only on CC 220 M

**Slot 3**

A **second** I/O card or a **second** servo card (Servo 6i, 4i or Servo 3i) can be fitted in slot 3.

**Slot 4**

The slot can be used alternatively for an I/O card, the RC-PLC I/O coupling card or RC-PLC bit coupling card. The system connection to the external PLC is established with this card (connecting cable RC-PLC bit to AG/Z or AG/P)

**rho 3.1 – PLC I/O Logic unit**



**Slot 3**

Slot for a second servo card (Servo 3i or Servo 4i). This slot is covered with a dummy panel if no card is equipped here.

**Slot 4**

The slot is intended for the RC-PLC I/O coupling card. The connection between the RC and PLC I/O modules is made internally via the backplane.

## 2.4. Electrical connection

The robot installation is normally supplied with power from the 3-phase AC mains supply. All internal system voltages are derived from this. The relevant standards and regulations must be taken into account for the mains power supply.

The electrical connections specific to the RC and PLC are described in the following sections

### 2.4.1. Power supply (general)



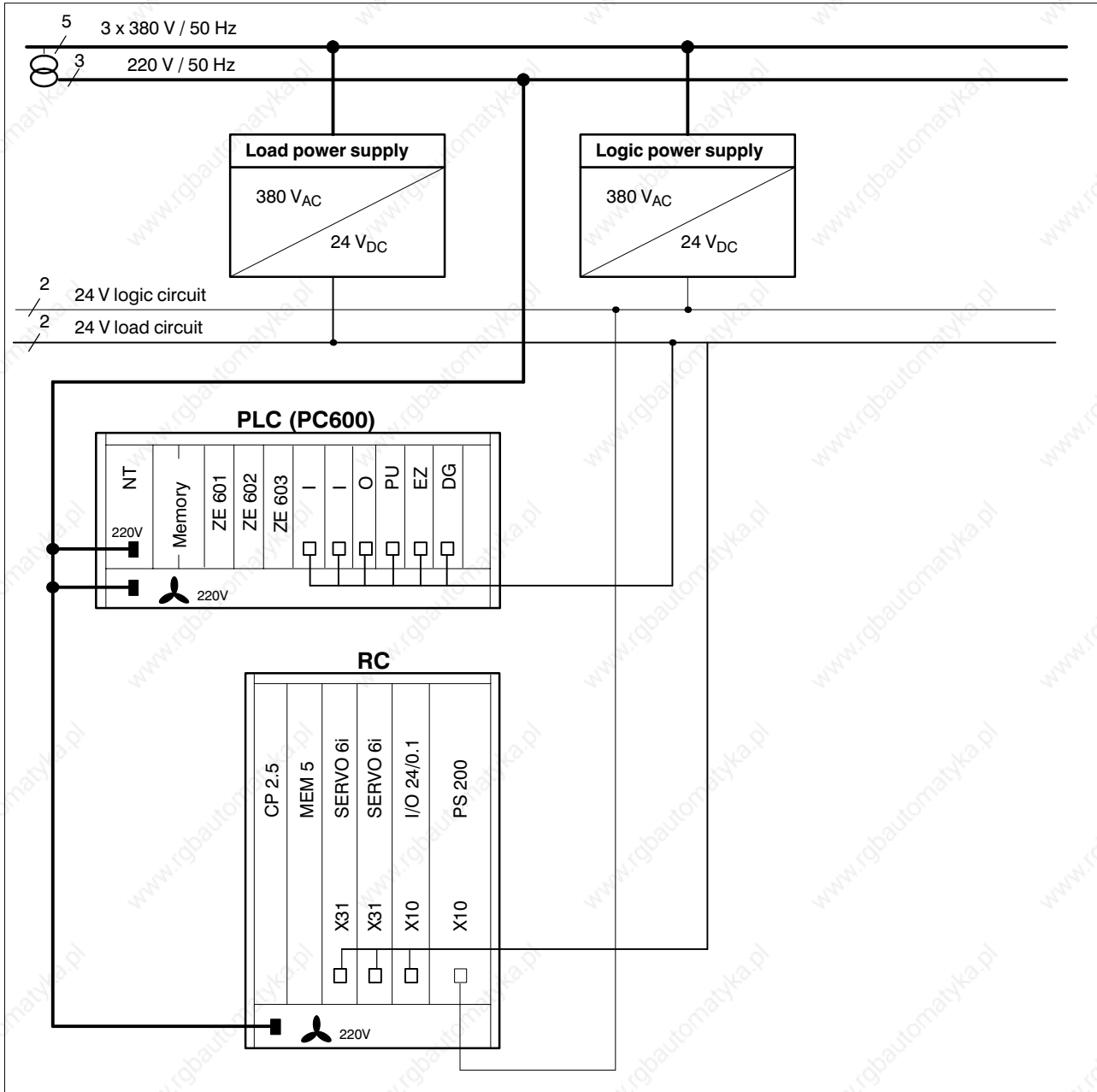



**2.4.2. Voltages and tolerances**

220 V supply	24 V logic supply	24 V load supply
<ul style="list-style-type: none"> <li>● 220 V<sub>Norm</sub> +10% / -15%</li> <li>● 48 – 62 Hz</li> <li>● max. interruption time 10 ms all 10 sec.</li> </ul>	<ul style="list-style-type: none"> <li>● 24 V<sub>DC</sub> , +30% / -15%</li> <li>● 5 A for powersupply PS 75 (*)</li> <li>● 6 A for power supply PS 200(**)</li> <li>● Residual ripple max. 1.2 V<sub>pp</sub> at U<sub>norm</sub></li> <li>● Max. interruption time 10 ms all 10 sec.</li> </ul>	<ul style="list-style-type: none"> <li>● 24 V<sub>DC</sub> , + 30% / -15% max.4 A I/O 24/0.1 (**)</li> <li>● for PLC dependent on configuration approx. 0.5 A for fan</li> <li>● Residual ripple max. 1.2 V<sub>pp</sub> at U<sub>norm</sub></li> </ul>
<p>(*) Values at U<sub>Norm</sub> (clock power supply) (**) Load dependent</p>		

**2.4.3. 24 V power supply for load and logic supply**



Power supplies to VDE 0550

Order number	913485	913486	913487	913488
Input voltage	380 V, 3-phase, 50 Hz			
Input current at nominal load	0.3 A~	0.45 A~	0.83 A~	1.7 A~
Input current in no-load condition	0.05 A~	0.08 A~	0.19 A~	0.19 A~
Output voltage	24 V <sub>DC</sub> ; +/- 10 % unregulated, residual ripple approx. 4.8 %			
Max. output current	6 A	10 A	20 A	40 A
Fuse (output side)	Mini. fuse with LED	Termal excess-current circuit – breaker (NEOZED)		Fuse
Efficiency at nominal load approx. .	72%	77%	80%	86%
Connection terminals	1.5 mm <sup>2</sup>	1.5 mm <sup>2</sup>	2.5 mm <sup>2</sup>	4 mm <sup>2</sup>
Isolation group	Group C for 380 V			
Type of protection	IP 00			
Dimensions in mm (W x H x D)	300x165x100	300x165x100	340x185x140	420x240x140
Weight in kg	6.3	6.4	10.9	19.5

**2.4.4. PE conductor, 0 V, neutral conductor, analog ground**

The potential bonding connections of all system parts (particularly between RC and drives) must be kept as short as possible.

All screens must be connected at both ends, subject to the precondition that the system parts are electrically networked.

**Exception:**

Refer to the individual drives for details of screen connection in the case of setpoint lines.



**Observe the relevant VDE regulations (e.g. VDE 0100) and the regulations of our local power supply company!**

**2.4.5. Voltage connection**



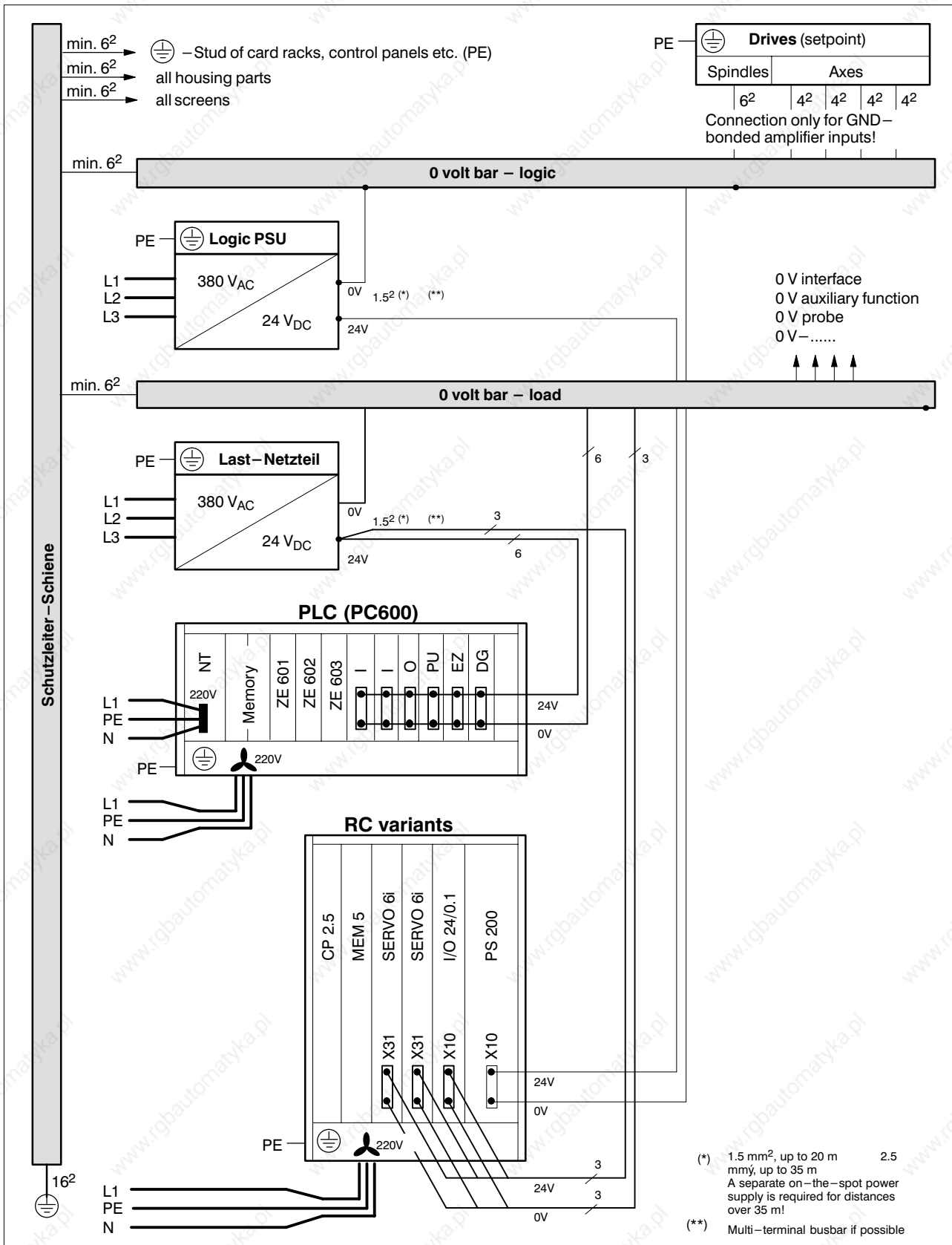

### 2.4.6. Interference suppression

Electrically operated and controlled machine installations can cause electromagnetic fields (radio and audio frequency) and disturbances in the mains power supply network. For this reason, interference suppression is necessary in accordance with the applicable regulations.

VDE regulations apply in addition to the corresponding legal regulations, e.g.:

#### **VDE 0874**

Principles for realization of measures for radio interference suppression

#### **VDE 0875**

Regulations for radio interference suppression of devices, machines and installations for nominal frequencies from 0 to 10 kHz.

The corresponding interference suppression measures have already been implemented in Bosch controls. However, the operating reliability of a control may be impaired by wire-carried interference.

The external circuitry (control cabinet) must therefore include

- spare-quenching circuits
- attenuation of inductive switching peaks
- limitation of the switching voltages of fast semiconductors
- screen

It is important that all these components are taken into account in interference suppression measures, since they produce an optimum and economical solution only as a whole.

#### **Please note**

- Perform interference suppression as close as possible to the source of interference.
- Limit leakage currents in accordance with the applicable safety regulations (shock-hazard protection!).
- Provide suppressors with good mechanical support in order to prevent breakage by vibration.
- Use only components which are identified as interference suppressors.

The question of electrical symmetry or asymmetry is also important. This is because asymmetrical interference voltages occur in addition to the symmetrical interference voltage components produced between the supplied cables. The former are caused, for example, by capacitive coupling of the interference source with the mains supply. The following diagram shows a common interference suppression circuit. Here, the asymmetrical interference voltages are discharged via  $C_y$  to the housing.  $C_x$  attenuates the symmetrical interference.



**Interference suppression examples**

**Contact circuitry**

(AC, DC, superposed DC)



- b) for sensitive contacts, residual current when contact is open!
- c) for highly-inductive load
- d) voltage-dependent resistance, residual current when contact is open

**Circuitry for an inductive load**

(Motors, solenoids, relay and contactor coils)



- c) drop-out delay for relays!
- d) defined drop-out delay for relays
- f) gas-discharge tube

**Mains power circuitry**



## 2.4. Operating conditions

### Ambient/operating conditions

Ambient temperatures from +5 °C to +55 °C.

If the angle from the vertical does not exceed  $\pm 30^\circ$  and a clearance of 100 mm (see dimension drawings) exists:

Storage temperature from  $-25^\circ\text{C}$  to  $+70^\circ\text{C}$ .

The ambient temperature may drop to  $0^\circ\text{C}$  when the control is switched on. The ambient temperature range refers to the temperature in the housing:

Temperature change rates of up to  $3^\circ\text{C}$  per minute are permitted.

### Humidity

Humidity class F in accordance with DIN 40 040.

The benchmark values for relative humidity are 50 % at  $40^\circ\text{C}$  and 90 % at  $20^\circ\text{C}$ . Dew formation in the control is not permitted.

### Mechanical loading

a) Vibration test \*)

**IEC 68–2–6**

Loading by 3 axes offset at  $90^\circ$  to each other

Test conditions:

Frequency range: 10 – 150 Hz

Deflection amplitude 10 – 57 Hz: 0.075 mm

Acceleration amplitude 57 – 150 Hz: 1 g

Test duration per axis: 10 frequency cycles

Frequency change rate: 1 octave/min

b) Shock test \*)

**IEC**

**68–2–27**

Shock loading with three shocks in each principal positive and negative axis direction

Pulse strength 15 g

Pulse duration 11 ms

Pulse shape semi-sinusoidal

c) Transport vibration test in accordance with Bosch guideline

**N42 AP 450**

\*) Examples apply to PLC

### Corrosive influences

The ambient air must be free of high concentrations of acids, lyes, corrosive agents, salts, metal vapors or other electrically conducted contamination.

### Electromagnetic interference

Strong electromagnetic fields must not occur in the direct proximity of the equipment.



**Interference immunity**

- a) Static discharge in accordance with IEC 801–2, severity better than 3.
- b) Conducted interference of the power supply in accordance with IEC 801–4, severity better than 3.
- c) Non–conducted interference IEC 801–3  
Test field strength in the frequency band 27–50 MHz > 10 V/m.

**Dirt (EN 60 204, Part 1 Paras. 7.2.1 and 8.1.2)**

Dust–free air is demanded for the environment of our built–in devices. Housings and compartments in which the devices are accommodated must comply at least with type of protection IP 54 in accordance with DIN 40 050.

**Installation position, installation location**

Installation position: vertical (card rack)  
Installation location: control cabinet installation  
in accordance with IP 54 (card rack)

**Positioning of the control panel**

The operating personnel must have a clear view from the control panel to the moved machine parts irrespective of the chosen location of the control.  
Direct sunlight reduces display readability and should be avoided.

**Control panel installation**

**Type of protection**

IP 20 in accordance with DIN 40 050 for card rack

**Air pressure**

In operation up to 3000 m above sea level.

**Boundary conditions**

Standards, regulations and guidelines

The control is based on the following standards and guidelines:

- Bosch safety guidelines
- VDE 0113 (EN 60 204) \*)
- VDE 0160 \*)
- IEC 801 (interference definitions) \*)
- IEC 68 (mechanical load)
- Humidity class F in accordance with DIN 40 040
- Types of protection in accordance with DIN 40 050 (also including IP 00, IP 20, IP 54).
- Transport vibration test in accordance with Bosch standard N42 AP 450
- Control connection and operation in accordance with IEC 550 and VDE 551

\*) is not completely satisfied



BVE 15239-5 A© Rechte bei ROBERT BOSCH GMBH, auch für den Fall von Schutzrechtsanmeldungen. Jede Verfügungsbefugnis, wie Kopier- und Weitergaberecht, bei uns.

## 2.6. Maintenance

The control electronics, interface cabinet and mechanical components of a robot installation must be serviced at regular intervals in order to guarantee problem-free operation.

### Caution!

Perform maintenance and inspection work only when the system is switched off and de-energized – if not otherwise described.

### 2.6.1. Control panels

- Clean the **monitor screen surface** at least **once weekly** with an anti-static cloth or window cleaning agent containing spirit.  
**Do not use any solvents** (thinner or similar).
- Readjust **screen brightness every 6 months**.
- Check **plug-in and terminal connections annually**.

### 2.6.2. Card rack

- Check **plug-in and terminal connections** annually.
- Check **ventilators of the plug-in fan units** annually to make sure that they are running properly and that ventilation is functioning.  
Check air filter mats for soiling. Watch out filter mats in soap solution if necessary. **Fit again only when they have dried.**  
Fit new filter mats if necessary.  
Order No.: 066796 (RC section); 066797 (PLC section)
- **Inspection of filter mats**

### Caution!

Revolving fan impeller. Perform maintenance work only in de-energized condition!

The plug-in fan unit is located in the **RC card rack** (filter support plate with ventilators) under the plug-in units and behind the cable duct.

The **RC/PLC card** possesses an additional plug-in fan unit underneath the PLC I/O modules (see figure).



### **RC card rack**

- The horizontal plug-in fan unit can be pulled out to the front after removing the cable duct (2 quick-release screws). Pay attention to the connecting cable! The filter mat is located under the support plate behind a inch-down frame.
- After inspection, carefully push in the support plate again together with the inserted filter mat. Screw on the cable duct again.

### **RC/SPS card rack**

- Undo the four screws on the cover plate. Remove the plate.
- Undo the quick-release screw of the filter support frame (with screwdriver or coin; 1/4 turn to left)
- Hinge up the filter support frame so that the filter mat can be removed.
- Insert the filter mat again after inspection. Press in the quick-release screw.
- Screw on the cover plate again.

### **2.6.3. CP/MEM 4 module**

- Replace the **buffer battery annually** (the Bosch shipment date applies). The battery **must** be replaced within 14 days after the error "CP/MEM BATTERY EMPTY" occurs for the first time at the latest.  
Battery type: Alkaline battery, 4.5 V.  
Perform battery replacement within 5 min. with the control **switched off** (data will be lost if this time is exceeded).

Procedure:

1. Control "Off".
2. Short-circuit new battery for approx. 2 sec.
3. Remove the cover for EPROM modules and battery socket.
4. Remove old battery and insert new one.  
Pay attention to polarity
5. Screw on battery cover again.

The processor/memory module CP/MEM4 must not be pulled out for battery replacement.

**Note:**

- Batteries must not be forcibly opened, charged or thrown into a fire.
- Dispose of exhausted batteries properly.

Refer to the section "CP/MEM4" for further information on the battery of the CP/MEM4.

#### **2.6.4. PLC modules**

Remember that the batteries of the PLC modules RAM600 and ZE603 must also be replaced annually. Please refer to the PLC manual for instructions on how to change the batteries in these modules.

### 3 Plug-in units

#### 3.1 Processor/memory module CP/MEM4



**Caution:**

The module CP/MEM4 must be removed only when the control is switched off. Internal RAM data (e.g. time) is then buffered for **max. 5 minutes**.

 **Input voltage**

**Input voltage 24 V dc logic (connector X10)**

Weidmüller terminal strip for connection of 24 V = (logic dc). The voltage connection must be routed directly from the logic power supply.

**Toggle switch 1**

Write protection for EEPROM ( $\hat{=}$  protected).

**Rotary switch S2**

Switch for internal test purposes.

**Buffer battery for data in RAM memory**

The battery must be replaced annually.

The battery voltage is automatically checked when the control is switched on. An error message "CP/MEM BATTERY EMPTY" appears if the voltage is too low. RAM buffering of at least 14 days is guaranteed after the first error display under normal battery charge conditions.

The CP/MEM4 possesses a capacitor for interim buffering of the data in the RAM. However, the voltage interruption must not exceed 5 min. when the battery is replaced while the control is switched off.

In order to change the battery, remove the battery cover and push the battery up out of the holder.

Battery 4.5 V, alkaline battery Order No. 107 – 913 572 The operating system is located on a soft board under the cover.

 **Data interfaces**

**Serial data interface 1 (connector X11)**

V24/20 mA interface for connection of a data terminal (socket X11, Sub-D, 25-pole).

Both interface variants (V24 and 20 mA) are wired at the socket. The V24 interface behaves like the 20 mA interface with respect to the data. Parameterization of the interface (baud rate, stop bits etc.) is performed via the PHG or by machine parameters.

Following parameters are set as defaults: 8 data bits , NO parity,  
1 stop bit, 9600 baud

Variable parameters: Baud rate 110–9600 baud, 1/1.5/2 stop bits.

**20mA interface (current loop)**

The following interface lines are used on the RC end:

TX+, TX– Transmit data, transmit line of the RC.

RX+, RX– Receive data, receive line of the RC.

DTR+, DTR– Data terminal ready, a HIGH signal indicates to the connected device that the RC is ready to receive.

DSR+, DSR– Data set ready, a HIGH signal indicates to the RC that the



connected device can receive data.

**GND** Signal ground.

In the case of a 20 mA connection, one device must always be connected as an active device and the other as a passive device (active: the device acts as current source). The 20 mA control interface can be switched active by jumpering pins 9 and 10.

The interface is parameterized as passive if this jumper is missing.

Technical data:

Level	HIGH:	approx. 20 mA (min. 12 mA)
	LOW:	approx. 0 mA (max. 3 mA).
Transfer rate:		max. 9600 baud with handshake.
Max. external voltage drop: (connected as 20 mA active)		3.5 V
(connected as 20 mA passive) driving device:		max. 12 V

**Notes on the 20 mA interface:**

- A handshake is possible only by device control (software handshake) for baud rates < 600 baud.
- The cable length should not be greater than 50 or 100 m for a 20 mA connection in order to ensure reliable data transfer. A maximum cable length of 100 m is permitted if the RC is used as the driving device (20 mA active). A maximum of 50 m is permitted if the peripheral interface functions as current source (CNC: 20 mA passive). Suitable repeaters must be installed in the line for greater distances.

**Serial data interface 2 (connector X12)**

**V24 interface (socket X12, Sub-D, 25-pole)**

The following interface lines are used on the RC end:

<b>TX</b>	Transmit data, transmit line of the RC.
<b>RX</b>	Receive data, receive line of the RC.
<b>DTR</b>	Data terminal ready, a HIGH signal indicates to the connected device that the RC is ready to receive.
<b>DSR</b>	Data set ready, a HIGH signal indicates to the RC that the connected device can receive data.
<b>GND</b>	Signal ground.

The status line CTS is not evaluated by the RC. Pin 4 (RTS) is permanently connected to 10 V on the RC end.

Technical data:

Level	HIGH:	+3V to +9V
	LOW:	-3V to -9V.
Transfer rate:		max. 9600 baud with handshake.

**Notes on V24 interface:**

- A handshake is possible only by device control (software handshake) for baud rate < 600 baud.
- The cable length for a V24 connection should not be greater than 15 m in order to ensure reliable data transfer. Either suitable repeaters must be connected in the line or the 20 mA interface used for greater distances.
- Pin 20 must be jumpered with pin 6 at the RC end if the connected device does not support a hardware handshake.

○ **Interface assignment x11, x12, x22**



**RGB signal (connector X21)**

This connection is not currently used on the rho3.

### 3.2 Processor/memory module CP/MEM5

The processor and memory module CP/MEM5 is compatible with CP/MEM4 and can be used as a replacement. Module CP/MEM5 is equipped with either a 15 Mhz CPU module or a 30 Mhz CPU module, depending on the customer's requirements. When the module is supplied, the front panel is marked to show which processor module is fitted.



---

**Caution:**

The CP/MEM5 module must only be disconnected when the controller is **switched off!** Internal RAM data (e.g. time) are then buffered for a **maximum of 5 minutes**.

---

### 3.2.1 Input Voltage

 **Input voltage 24V dc logic (connection X10)**

Weidmüller terminal strip for connection of 24V<sub>=</sub> (Logic dc). The power connection must be routed directly from the logic mains unit.

**Rocker switch S1**

Write protection for EEPROM (1<sup>∧</sup>=protected).

**Rotary switch S2**

Switch for internal test purposes

**Buffer battery for data in RAM memory**

The battery must be replaced once a year!

The battery voltage is automatically tested when the controller is switched on. If low voltage is detected, an error message appears

“CP/MEM BATTERY EMPTY”.

With a normal battery charge, RAM buffering of at least 14 days is assured after the first error display.

The CP/MEM5 has a condenser for intermediate buffering of the data in the RAM memory. When the battery is replaced quickly with the controller switched off, however, the power interruption must not last more than 5 minutes.

To change the battery, remove the battery cover and push the battery up out of the bracket.

Battery: 4.5 alkali battery, order No. 107 - 913 572

The operating system is located on a pluggable circuit board (soft board) under the cover.

### 3.2.2 Data Interfaces on CP/MEM 5

#### ○ **Serial data interface 1 (terminal X11)**

V24/20mA interface for connection of a data terminal unit  
(Socket X11, SUB-D, 25-pole)

Both interface varieties (V24 and 20 mA) are wired on the socket.  
As far as the data are concerned, the V24 interface acts just the same as the 20mA interface. The parameterisation of the interface (baud rate, stop bits etc.) is implemented via the PHG or by machine parameters.

The following parameters are implemented:

	8 data bits, NO parity,
	1 stop bit, 9600 baud
Variable parameters:	Baud rate 110-9600 baud,
	1/1.5/2 stop bits.

#### ○ **20mA interface (current loop)**

On the RC side, the following interface lines are used:

TX+, TX-	Transmit data, transmission line of RC.
RX+, RX-	Receive data, reception line of RC.
DTR+, DTR-	Data terminal ready, HIGH signal tells the connected device that the RC is ready for reception.
DSR+, DSR-	Data set ready, HIGH signal tells the RC that the connected device can accept data.
GND	Signal ground.

In the 20 mA connection, one device must always be switched as the active device, the other as the passive one (active: the device works as the power source). The 20mA interface of the controller is switched active by bridging pins 9 and 10. If this bridge is not present, the interface is parameterised as passive.

#### Technical data:

Level:	HIGH:	appr. 20 mA (min. 12 mA)
	LOW:	appr. 0 mA (max. 3 mA)
Transmission rate:		max. 9600 baud with handshake.
Max. external voltage fall: (switched as 20mA active)		3.5 V
Voltage fall in the controller: (switched as 20mA passive)		max. 3.5 V
Power supply of the leading device		max. 12 V

#### ○ **Notes on the 20mA interface:**

- For baud rates < 600 baud, handshake is only possible via the device control (software handshake).
- For reliable data transmission, the cable length for a 20mA connection should be **no more than 50 or 100 m**. If the RC is used as the leading device (20 mA active), the maximum permitted cable length is 100 m. If the peripheral interface works as the power source (CNC: 20 mA passive), the maximum permitted length is 50 m. For longer distances, suitable intermediate repeaters must be included.



**Serial data interface 2 (terminal X12)**

**V24 interface (socket X12, SUB-D, 25-pole)**

On the RC side, the following interface lines are used:

TX	Transmit data, transmission line of RC.
RX	Receive data, reception line of RC.
DTR	Data terminal ready, HIGH signal tells the connected device that the RC is ready for reception.
DSR	Data set ready, HIGH signal tells the RC that the connected device can accept data.
GND	Signal ground.

The status line CTS is not evaluated by the RC. Pin 4 (RTS) is permanently connected to 10V on the RC side.

**Technical data:**

Level:	HIGH:	+3V to +9V
	LOW:	-3V to -9V
Transmission rate:		max. 9600 baud with handshake.

**Notes on the V24 interface:**

- For baud rates < 600 baud, handshake is only possible via the device control (software handshake).
- For reliable data transmission, the cable length for a V24 connection should **not be greater than 15 m**. For greater distances, either suitable intermediate repeaters must be installed, or the 20mA interface must be used.
- If the connected device does not support a hardware handshake, pin 20 must be bridged with pin 6 on the RC side.



**3.2.3 Interface assignment x11,x12,x22**



**RGB signal (terminal X21)**

This connection is currently not used in the rho3.

### 3.3. Processor module CP 2.5



**Caution:**

The processor module CP2.5 must be removed only when the control is switched off. Internal RAM data (e.g. time) is then buffered for a maximum of 10 minutes.

**NMI pushbutton**

The READY 2 contact drops out when this pushbutton is pressed.

**Rotary switch for baud rate**

Currently no function if CP 2.5 is used as the processor module of the rho 3.

**Rotary switch S2**

Currently no function if the CP 2.5 is used as the processor module of the rho 3.

**Terminals 2–5 (connector X13)**

4 interfaces are available at this connector.

- Interface for PHG connection
- Two RS232/V24 or 20 mA interfaces
- One interface in accordance with RS422

The interfaces are controlled by a separate intelligent module which is plugged onto the CP 2.5 card.

The following diagram shows the assignment of the 50-pole D-sub socket.

An interface distributor AF5 with corresponding cables is available for connection purposes.

The 20 mA interfaces can also be operated in active mode. In this case, 12 V must be supplied externally.



**Terminal 1 (connector X11)**

A combined V24/RS232, 20 mA interface is available at connector X11. The pin assignment is shown in the following diagrams.



**V24 interface**

The following interface lines are used on the RC end:

- TX Transmit data, transmit line of the RC.
- RX Receive data, receive line of the RC.
- DTR Data terminal ready, a HIGH signal indicates to the connected device that the RC is ready to receive.
- DSR Data set ready, a HIGH signal indicates to the RC that the connected device can receive data.
- GND Signal ground.

The status line CTS is not evaluated by the RC. Pin 4 (RTS) is permanently connected to 10 V on the RC end.

Pin 20 must be jumpered with pin 6 at the RC end if the connected device cannot generate any status signals.

Technical data:

- Level HIGH: +3V to +9V  
LOW: -3V to -9V.
- Transferrate: max. 9600 baud with handshake.

Information on V24 interface:

- A handshake is possible only by device control (software handshake) for baud rates < 600 baud.
- The cable length for a V24 connection should not be greater than 15 m in order to ensure reliable data transfer. Either suitable repeaters must be connected in the line or the 20 mA interface used for greater distances.
- It is possible to restrict the maximum transfer rate to values of < 9600 Baud if special line drivers or receivers are used. In this case, refer to the technical data of the devices in question.
- Pin 20 must be jumpered with pin 6 at the CNC end if the connected device does not support a hardware handshake.

**20 mA interface (current loop)**



The following interface lines are used at the RC end:

TX+, TX-	Transmit data, transmit line of the RC.
RX+, RX-	Receive data, receive line of the RC.
DTR+, DTR-	Data terminal ready, a HIGH signal indicates to the connected device that the RC is ready to receive.
DSR+, DSR-	Data set ready, a HIGH signal indicates to the RC that the connected device can receive data.
GND	Signal ground.

Other status lines (RTS, CTS) are not set or evaluated by the RC.

In the case of a 20 mA connection, one device must always be connected as an active device and the other as a passive device (active: the device acts as current source). The 20 mA control interface can be switched active by jumpering pins 9 and 10. The interface is parameterized as passive if this jumper is missing.

Technical data:

Level	HIGH:	ca. 20 mA (min. 12 mA)
	LOW:	ca. 0 mA (max. 3 mA).
Transfer rate:		max. 9600 baud with handshake.
Max. external voltage drop: (connected as 20 mA active)		3.5 V
Voltage drop in control: (connected as 20 mA passive)		max. 3.5 V
Power supply of the driving device:		max. 12 V

Information on 20 mA interface:

- A handshake is possible only by device control (software handshake) for baud rates < 600 baud.
- The cable length for a 20 mA connection should **not be greater than 50 or 100 m** in order to ensure reliable data transfer. A maximum cable length of 100 m is permitted if the RC is used as the driving device (20 mA active). A maximum length of 50 m is permitted if the peripheral interface acts as the current source (RC: 20 mA passive). Suitable repeaters must be connected in the line for greater distances.
- It is possible to restrict the maximum transfer rate to values of < 9600 baud if special line drivers or repeaters are used. Please refer to the technical data of these devices if they are used.

**System Intercon (connector X12)**

Being prepared.

Party line connection to connect the logic unit with the control panel of the rho 3.2.  
(Socket, Sub-D, 15-pole).



### 3.4. Memory module MEM 5

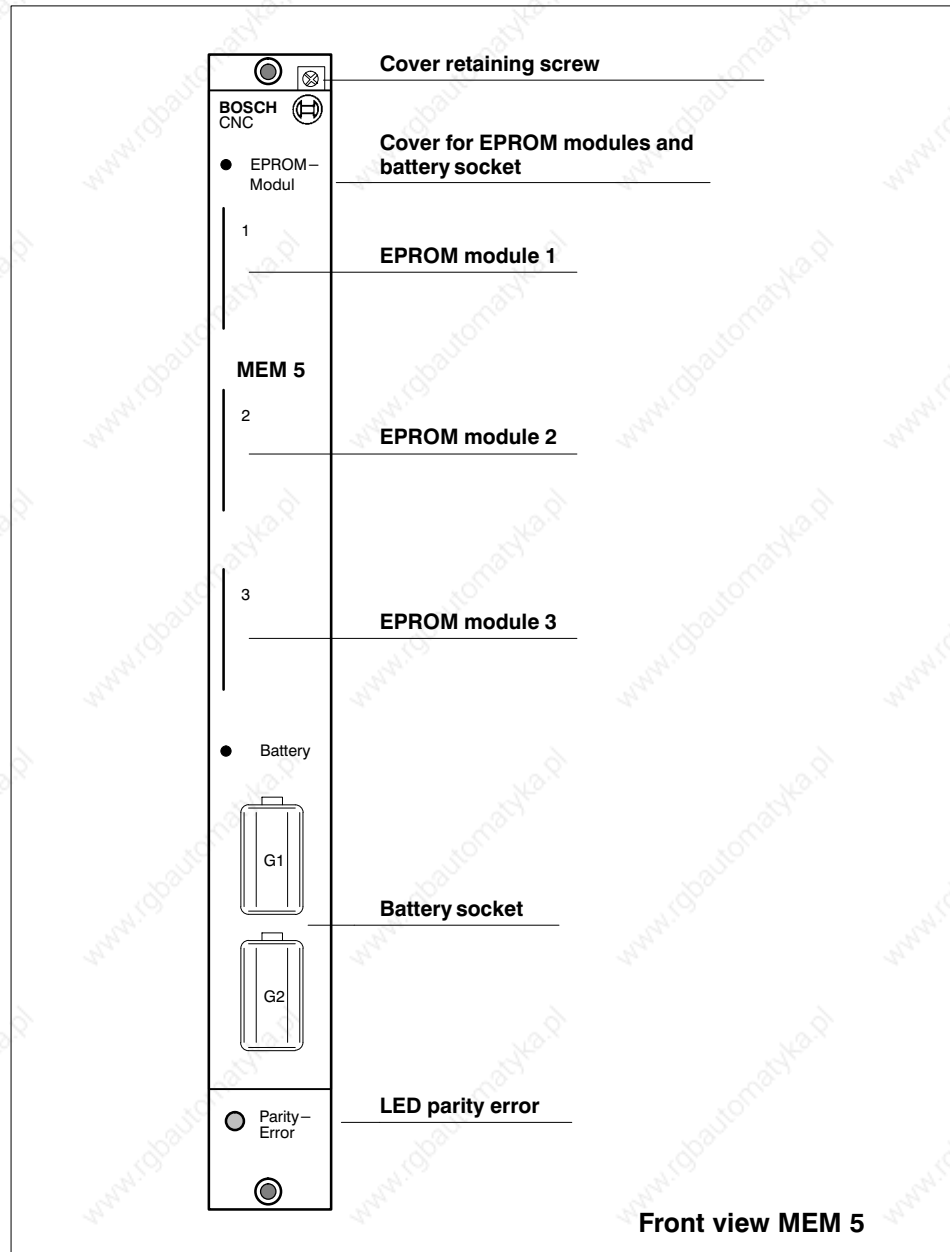

**Caution:**

The memory module MEM 5 must be removed only when the control is **switched off**.

If the memory module MEM 5 is removed, never remove both batteries at the same time, otherwise all data in the RAM will be lost.

Please remember that internal RAM data and the current time **of the CP 2.5** are also buffered by the batteries of the MEM 5. **The data of the CP 2.5** is buffered for a maximum of 10 minutes if the control is switched off and the MEM 5 removed.

**Basic configuration of the MEM 5:**

- 512 kByte RAM
- 32 kByte EEPROM

**Options:**

- RAM: 1 MByte, 2.5 MByte
- EEPROM: 64 kByte

**RAM**

Memory area for part programs. The whole RAM area is buffered in order to prevent data information loss when the control is switched off (or when the module is removed) (also see the section "Battery").

**EEPROM**

This memory area is used to save the machine parameters.

The MEM 5 can be equipped with up to 3 EPROM modules on which the operating system software of the rho 3 is stored; 2 of these modules are currently used.

**Battery**

2 lithium batteries are used (size C, 3.6 V, Order No. 046800), each with a capacity of 5.2 Ah for buffering the MEM5 RAM area. The typical value of the buffer time is around **1 year per battery** (replace with cycle: annual). The batteries are connected in the hardware in such a way that the battery which is fitted first is discharged first. The unused battery is in "standby mode".

The batteries are protected against reverse polarity, short-circuits and leakage. The corresponding battery must be replaced **within 30 days** after the error "MEM-BATTERY 1 EMPTY" or "MEM BATTERY 2 EMPTY" appears for the first time. Refer to the section "**Maintenance**" for battery replacement instructions.

**LED parity error**

The LED indicates a parity error in the RAM area of MEM 5. The READY contact (see PS200) is opened in the event of a parity error. **The control is then no longer ready for operation!**

It may be possible to remedy the error by restarting the control (Reset); otherwise, the MEM card must be replaced.

### 3.5 Servo loop interface SERVO 3–5

The servo card is used for output of the analog speed setpoints and closes the position control loop by evaluation of the signals of the connected incremental position measuring systems. The servo sampling rate depends on machine parameter **P5**. The overall system may contain a maximum of one SERVO 3–5. A mixed configuration (SERVO 3–5/ SERVO 6i) is permitted.

#### 3.5.1 Overview



**Caution:**

The servo card SERVO 3–5 must be removed only when the control is switched off!

**Basic configuration of the SERVO 3:**

- 3 axis

**Options:**

- Upgrading for up to 5 axes

**3.5.2 Measuring system inputs**

(Sockets X11 to X15)

Measuring systems from Messrs. Heidenhain are used. These are suitable either for direct connection or connection via a pulse shaper (EXE). The connection instructions of the manufacture with respect to cable lengths and routing must be observed.

The power supply for a directly connected encoder or an EXE with external 5 V supply is provided via the measuring system input socket.

The following data generally applies to SERVO 3 – 5 measuring system inputs:

- Max. permissible cable length/input: 35 m or manufacturer's specification
- Max. permissible cable length difference at all inputs : 15 m
- Cable type: Special cable NFS 7264  
0 x 0.14 mm<sup>2</sup> + 4 x 0.5 mm<sup>2</sup>  
(not for trailing operation!)
- Signal inputs: Differential line receiver  
R<sub>i</sub> = 120 Ω
- Input signals: A, B, R,  $\bar{A}$ ,  $\bar{B}$ ,  $\bar{R}$  (TTL level);  
min. voltage differences between  
A and  $\bar{A}$ , B and  $\bar{B}$ , R and  $\bar{R}$   $\geq$  600 mV
- Pulse multiplication: Quadruplication of the input frequency (four-edge evaluation)
- Max permitted input frequency: 500 kHz
- Encoder/EXE power supply: +5 V (adjustable at PSU PS200)
- Max. permissible current consumption per encoder/EXE 350 mA

The signal lines of the measuring systems must be connected exactly in accordance with these conditions. **It is not permitted to change around the signal lines for the purpose of direction reversal owing to the resultant decoding of the zero pulse!** Direction reversal is possible in the software by means of the machine parameters.



### 3.5.3 Approved digital measuring systems

The system combinations from the ROD/LS and EXE product range of Messrs. Heidenhain must be adapted individually to the requirements of the machine and control in question.

In principle, it is possible to install direct-connection rotary encoders from Messrs. Heidenhain subject to the following preconditions:

- 5 V encoder power supply
- Square-wave signal output
- Line driver in accordance with RS 485
- Encoder current consumption < 350 mA
- Min. edge spacing between two active counting pulses  $\geq 250 \text{ ns}$
- Min. edge spacing for direction reversal  $\geq 0 \text{ ns}$
- Safety distance for reference signal  $\geq 100 \text{ ns}$

In addition, it is possible to install EXEs from Messrs. Heidenhain if the following preconditions are satisfied:

- 5 V or external 220 V power supply
- Square-wave signal output
- Line drive in accordance with RS 485
- Max. encoder and EXE current consumption with 5 V supply: < 350 mA
- Min. edge spacing between active counting pulses  $\geq 250 \text{ ns}$
- Min. edge spacing for direction reversal  $\geq 0 \text{ ns}$
- Safety distance for reference signal  $\geq 100 \text{ ns}$

### 3.5.4 Rotary measuring systems

- Rotary encoder f. direct conn.:
 

ROD 220 (Messrs. Heidenhain)
ROD 420                   "
ROD 426                   "
ROD 428                   "

**Recommended rotary encoders for direct connection:**

ROD 428                   "

- Rotary encoders for connection via EXE 604 C, EXE 605 C:
 

ROD 250 (Messrs. Heidenhain)
ROD 450                   "
ROD 456                   "
ROD 700                   "
ROD 800                   "

- Rotary encoder for connection via EXE 702, EXE 816:
 

ROD 800 (Messrs. Heidenhain)
------------------------------

### 3.5.5 Linear measuring systems

- Linear scales for connection to EXE 604 C, EXE 605 C, EXE 610, EXE 801, EXE 802, EXE 803, EXE 804, EXE 805, EXE 813:
 

LS 703 (Messrs. Heidenhain)
LS 707                   "
LS 903                   "

- Linear scales for connection to EXE 808, EXE 816:
 

LS 300 (Messrs. Heidenhain)
LIDA 325               "

**Recommended electronic pulse shaper (EXE)**

Of the EXEs with external 5 V supply, we recommend the following:

- EXE 604 C (Messrs. Heidenhain)

However, EXEs with own 220 V power supply should be preferred.

**Recommendation for electronic pulse shaper (EXE) and encoder**

We recommend using the EXE 604 C and encoder ROD 428. These types do not have any capacitive connection between 0 V of the supply voltage and the housing. This leads to higher interference immunity. In addition, these types possess an extended measuring system monitoring function which informs the Bosch control of errors by tri-state switching of the output signals. The EXE 604 C was developed specially for Bosch controls. It corresponds to the EXE 601 and addi-

tionally possesses a ground stud as well as a 12–pole Souriau connector at the RC end.

**Notes:**

- The list of suitable measuring systems can only be considered as a general recommendation owing to frequent technical modifications and increasing product priority.
- Please enquire if it is wished to use other measuring systems.
- The encoder supply voltage is  $+5\text{ V} \pm 5\%$  for all connected encoders and the permitted cable lengths (measured directly at the encoder input). The encoder supply voltage is set at the potentiometer  $V_{MS}$  of the power supply when PS200 is used.
- The encoder cable from the RC control to the ROD encoder can be supplied by Bosch. This is equipped with a 15–pole Sub–D connector at the RC end and a 12–pole circular socket of the type "Souriau" at the encoder end. Preassembled encoder cables are available with length of 5 m, 8 m, 16 m, 25 m, 35 m .
- If the ROD encoder is supplied by Bosch, its cable (0.5 m) is equipped with a circular connector of the type "Souriau".

---

 **The error signal Uas is not evaluated by the SERVO 8. The EXEs 604 C and 605 C signal a measuring system error by tri–state switching of the output signals. If the EXEs 604 C and 605 C are not used, this means that any errors which occur in the area of the measuring system – EXE input cannot be detected! In this case, the user must take other suitable protective measures.**

---

### 3.5.6 Pin assignments

The cable shield must possess a continuous connection from the front panel of the SERVO 3 – 5 to the measuring system.

**The connector pin assignment applies only to cables and encoders supplied by BOSCH**



The connecting cables from EXE to the measuring systems are cables from Messrs. Heidenhain.





**Cable: Servo – measuring system (ROD)**



**Pin assignment**

Color	Connector X11	Color	Socket X2
white–yellow	1	white–yellow	1
green	2	green	2
grey	3	grey	3
pink	4	pink	4
brown 0.5 □	5	brown 0.5 □	5
white	6	white	6
white–grey	7	white–grey	7
violet	8	violet	8
red 0.5 □	9	red 0.5 □	9
black 0.5 □	10	black 0.5 □	10
blue 0.5 □	12	blue 0.5 □	12
Screen	Connector housing	Screen	11

### 3.5.7 Analog setpoint outputs

(Connectors X21 )

Speed–proportional voltages for controlling the individual axes are available at these outputs. The spindle must be considered as an asynchronous axis.

---

 **An undefined output voltage may be output at the setpoint outputs of the SERVO 3–5 when the control is switched off. For this reason, the load voltage must be switched off first and then the logic voltage when the control is switched off.**

---

In addition, the following points must be observed with respect to the analog setpoint outputs of the SERVO 3–5 :

- Recommended cable type: Belden 2 x 0.5 mm<sup>2</sup> (8762–20)
- The screen connection depends on the drives used (e.g. for Servodyn T: connection at both ends).
- Max. output range:  $\pm 10,0$  V
- Output voltage (rapid traverse):  $\pm (-) 7,5$  V
- The output voltages are non–isolated.
- Permitted load resistance at output: min. 10 k $\Omega$
- The output stages are resistant to sustained short circuits. However, if several outputs are short–circuited, the output operational amplifier may be destroyed as a result of the increased power loss.
- The inputs at the drive amplifiers must be connected as a difference amplifier. Ground–bonded circuits must be avoided.

### 3.5.7.1 Pin assignments analog setpoint output



### 3.5.8 Probe inputs / 5V probe switching voltage

#### (Connector X31)

Connector X31 has two inputs (24 V DC, 5 V DC) for switching probes (label on front panel: "Pr"). Internally, the two inputs are linked via an OR function.

An additional switching voltage for a 5V probe is also available (load capacity: max. 10 mA). This voltage can be switched by the switching contact of a probe and returned to the controller at the 5 V DC probe input.

The inputs of connector X31 are used in the rho 3 controller in the configuration level "fast measuring".

Further information on this function can be found in document "rho 3 software Releases", article No. 073077, and in document "rho3 description of machine parameters", article No. 073027.

#### 3.5.8.1 Technical data, probe inputs

The following general points must be taken into account for the probe inputs of the SERVO :

- The input signals must be free from radio interference and bounce. .
- Shielded cables must be used.
- An open input is detected as "logically 0".
- All inputs are galvanically isolated from the logic voltage by optical couplers.

##### 24 V probe input

- Max. permissible input voltage: +32 V
- HIGH level: +17 to +32 V
- LOW level: -3 bis +5 V (or open input)
- Rated input current (at 24 V): 8 mA
- Typical switching threshold: +12 V

##### 5 V probe input

- Max. permissible input voltage: +6 V
- HIGH level: +4 to +6 V
- LOW-Pegel: -3 to +0.8 V (or open input)
- Rated input current (at 5 V): 8 mA
- Typical switching threshold: +3 V

### 3.5.8.2 Pin assignment, probe inputs



**3.5.8.3 Connection options for probes**



### 3.6. Servo loop interface SERVO 8

The servo card is used for output of the analog speed setpoints and closes the position control loop by evaluation of the signals of the connected incremental position measuring systems. The servo sampling rate depends on machine parameter **P5**. The overall system may contain a maximum of one SERVO 8. A mixed configuration (SERVO 8 / SERVO 6i) is permitted.

#### 3.6.1. Overview



**Caution:**

The servo card SERVO 8 must be removed only when the control is switched off!

**Basic configuration of the SERVO 8:**

- 5 axis

**Options:**

- Upgrading for up to 8 axes
- High Speed I/O

**3.6.2. Measuring system inputs**

(Sockets X11 to X18) (X16 to X18 optional)

Measuring systems from Messrs. Heidenhain are used. These are suitable either for direct connection or connection via a pulse shaper (EXE). The connection instructions of the manufacture with respect to cable lengths and routing must be observed.

The power supply for a directly connected encoder or an EXE with external 5 V supply is provided via the measuring system input socket.

The following data generally applies to SERVO 8 measuring system inputs:

- Max. permissible cable length/input: 50 m or manufacturer's specification
- Max. permissible cable length difference at all inputs : 15 m
- Cable type: Special cable NFS 7264  
0 x 0.14 mm<sup>2</sup> + 4 x 0.5 mm<sup>2</sup>  
(not for trailing operation!)
- Signal inputs: Differential line receiver  
R<sub>i</sub> = 120 Ω
- Input signals: A, B, R,  $\bar{A}$ ,  $\bar{B}$ ,  $\bar{R}$  (TTL level);  
min. voltage differences between  
A and  $\bar{A}$ , B and  $\bar{B}$ , R and  $\bar{R}$   $\geq$  600 mV
- Pulse multiplication: Quadruplication of the input frequency (four-edge evaluation)
- Max permitted input frequency: 500 kHz
- Encoder/EXE power supply: +5 V (adjustable at PSU PS200)
- Max. permissible current consumption per encoder/EXE 350 mA

The signal lines of the measuring systems must be connected exactly in accordance with these conditions. **It is not permitted to change around the signal lines for the purpose of direction reversal owing to the resultant decoding of the zero pulse!** Direction reversal is possible in the software by means of the machine parameters.



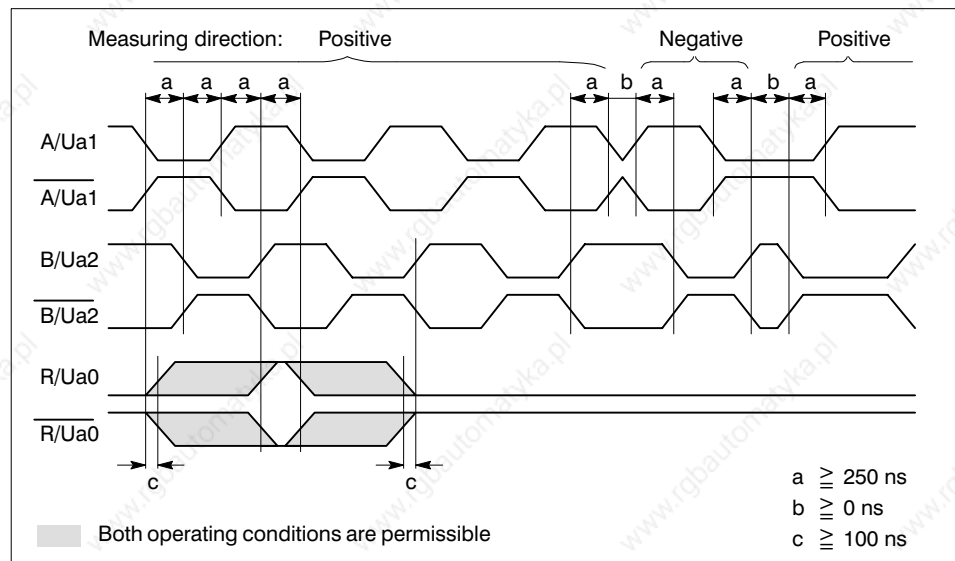

### Approved digital measuring systems

The system combinations from the ROD/LS and EXE product range of Messrs. Heidenhain must be adapted individually to the requirements of the machine and control in question.

In principle, it is possible to install direct-connection rotary encoders from Messrs. Heidenhain subject to the following preconditions:

- 5 V encoder power supply
- Square-wave signal output
- Line driver in accordance with RS 485
- Encoder current consumption < 350 mA
- Min. edge spacing between two active counting pulses  $\geq$  250 ns
- Min. edge spacing for direction reversal  $\geq$  0 ns
- Safety distance for reference signal  $\geq$  100 ns

In addition, it is possible to install EXEs from Messrs. Heidenhain if the following preconditions are satisfied:

- 5 V or external 220 V power supply
- Square-wave signal output
- Line drive in accordance with RS 485
- Max. encoder and EXE current consumption with 5 V supply: < 350 mA
- Min. edge spacing between active counting pulses  $\geq$  250 ns
- Min. edge spacing for direction reversal  $\geq$  0 ns
- Safety distance for reference signal  $\geq$  100 ns

### Rotary measuring systems

- |                                   |                              |
|-----------------------------------|------------------------------|
| ○ Rotary encoder f. direct conn.: | ROD 220 (Messrs. Heidenhain) |
|                                   | ROD 420 "                    |
|                                   | ROD 426 "                    |
|                                   | ROD 428 "                    |

**Recommended rotary encoders for direct connection:**

ROD 428       ”

- Rotary encoders for connection via EXE 604 C, EXE 605 C:
  - ROD 250 (Messrs. Heidenhain)
  - ROD 450       ”
  - ROD 456       ”
  - ROD 700       ”
  - ROD 800       ”

- Rotary encoder for connection via EXE 702, EXE 816:       ROD 800 (Messrs. Heidenhain)

**Linear measuring systems**

- Linear scales for connection to  
EXE 604 C, EXE 605 C, EXE 610,  
EXE 801, EXE 802, EXE 803  
EXE 804, EXE 805, EXE 813:
 

LS 703 (Messrs. Heidenhain)	
LS 707	”
LS 903	”
  
- Linear scales for connection to  
EXE 808, EXE 816:
 

LS 300 (Messrs. Heidenhain)	
LIDA 325	”

**Recommended electronic pulse shaper (EXE)**

Of the EXEs with external 5 V supply, we recommend the following:

- EXE 604 C (Messrs. Heidenhain)

However, EXEs with own 220 V power supply should be preferred.

**Recommendation for electronic pulse shaper (EXE) and encoder**

We recommend using the EXE 604 C and encoder ROD 428. These types do not have any capacitive connection between 0 V of the supply voltage and the housing. This leads to higher interference immunity. In addition, these types possess an extended measuring system monitoring function which informs the Bosch control of errors by tri–state switching of the output signals. The EXE 604 C was developed specially for Bosch controls. It corresponds to the EXE 601 and additionally possesses a ground stud as well as a 12–pole Souriau connector at the RC end.

**Notes:**

- The list of suitable measuring systems can only be considered as a general recommendation owing to frequent technical modifications and increasing product priority.
- Please enquire if it is wished to use other measuring systems.
- The encoder supply voltage must be adjusted so that the encoder supply voltage is +5 V +/- 5 % for all connected encoders and the permitted cable lengths (measured directly at the encoder input). The encoder supply voltage is set at the potentiometer  $V_{MS}$  of the power supply PS200.
- The encoder cable from the RC control to the ROD encoder can be supplied by Bosch. This is equipped with a 15–pole Sub–D connector at the RC end and a 12–pole circular socket of the type "Souriau" at the encoder end. Preassembled encoder cables are available with length of 5 m, 8 m, 16 m, 25 m, 35 m or 50 m.
- If the ROD encoder is supplied by Bosch, its cable (0.5 m) is equipped with a circular connector of the type "Souriau".

---

 **The error signal Uas is not evaluated by the SERVO 8. The EXEs 604 C and 605 C signal a measuring system error by tri-state switching of the output signals. If the EXEs 604 C and 605 C are not used, this means that any errors which occur in the area of the measuring system – EXE input cannot be detected! In this case, the user must take other suitable protective measures.**

---

### 3.6.3. Pin assignments

The cable screen must possess a continuous connection from the front panel of the SERVO 8 (screen terminals) to the measuring system.

**The connector pin assignment applies only to cables and encoders supplied by BOSCH**



The connecting cables from EXE to the measuring systems are cables from Messrs. Heidenhain.

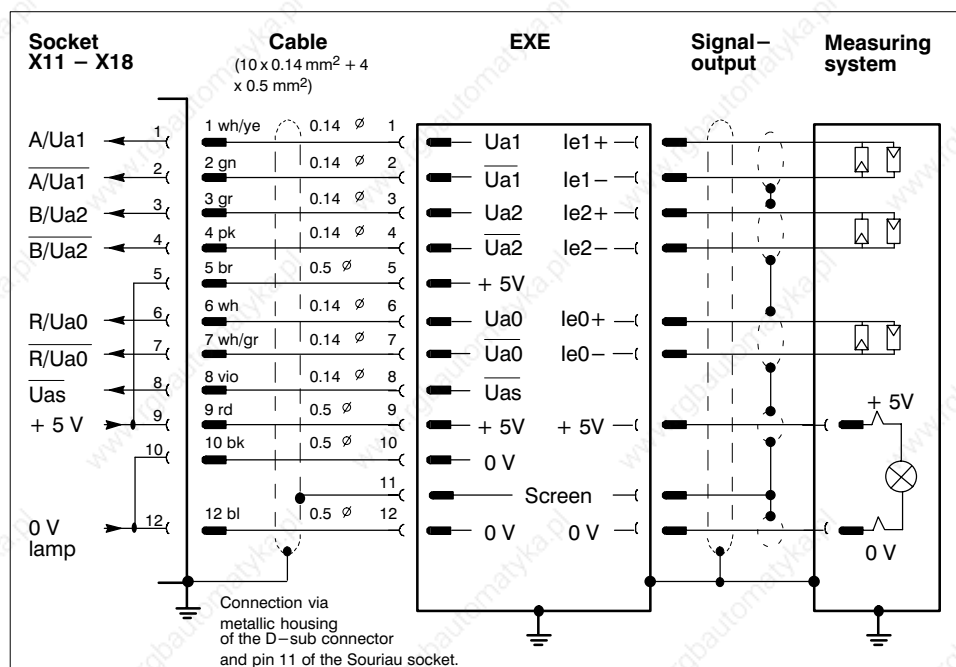

**Cable: Servo – measuring system (ROD)**



**Pin assignment**

Color	Connector X11	Color	Socket X2
white–yellow	1	white–yellow	1
green	2	green	2
grey	3	grey	3
pink	4	pink	4
brown 0.5 □	5	brown 0.5 □	5
white	6	white	6
white–grey	7	white–grey	7
violet	8	violet	8
red 0.5 □	9	red 0.5 □	9
black 0.5 □	10	black 0.5 □	10
blue 0.5 □	12	blue 0.5 □	12
Screen	Connector housing	Screen	11

### 3.6.4. Analog setpoint outputs

(Connectors X21 and X22) (X22 optional)

Speed-proportional voltages for controlling the individual axes are available at these outputs. The spindle must be considered as an asynchronous axis.

---

 **An undefined output voltage may be output at the setpoint outputs of the SERVO 8 when the control is switched off. For this reason, the load voltage must be switched off first and then the logic voltage when the control is switched off.**

---

In addition, the following points must be observed with respect to the analog setpoint outputs of the SERVO 8:

- Recommended cable type: Belden 2 x 0.5 mm<sup>2</sup> (8762–20)
- The screen connection depends on the drives used (e.g. for Servodyn T: connection at both ends).
- Max. output range:  $\pm 13.3\text{ V}$
- Output voltage (rapid traverse):  $\pm 10\text{ V}$
- The output voltages are non-isolated.
- Permitted load resistance at output: min. 10 k $\Omega$
- The output stages are resistant to sustained short circuits. However, if several outputs are short-circuited, the output operational amplifier may be destroyed as a result of the increased power loss.
- The inputs at the drive amplifiers must be connected as a difference amplifier. Ground-bonded circuits must be avoided.

**Pin assignments**









### 3.7. Servo card modular SERVO

The servo card (modular Servo) is used for output of analog speed setpoints and closes the position servo loop by evaluation of the signals of the connected position measuring systems. The servo sampling rate depends on machine parameters P5. The overall system may contain a maximum of one modular SERVO. A mixed configuration (modular SERVO/SERVO 6i) is permitted.

Die modulare Servokarte ist für unterschiedliche Meßsysteme modular bestückbar .

The modular servo card is suitable for modular installation on conjunction with different measuring systems.

Evaluation modules are available for the following measuring systems:

**Incremental module**, one module per measuring system

**Absolute module**, one module per measuring system

**Potentiometer module**, for up to 12 potentiometer measuring systems;  
this module occupies 2 module slots.

Up to 8 analog outputs are available on the card. These are used for output of the nominal speed. Outputs which are not assigned to any controlled axis can be used for other functions (refer to rho 3 description of machine parameters and rho 3 description of additional features).

**3.7.1. Overview of modular Servo abs8**

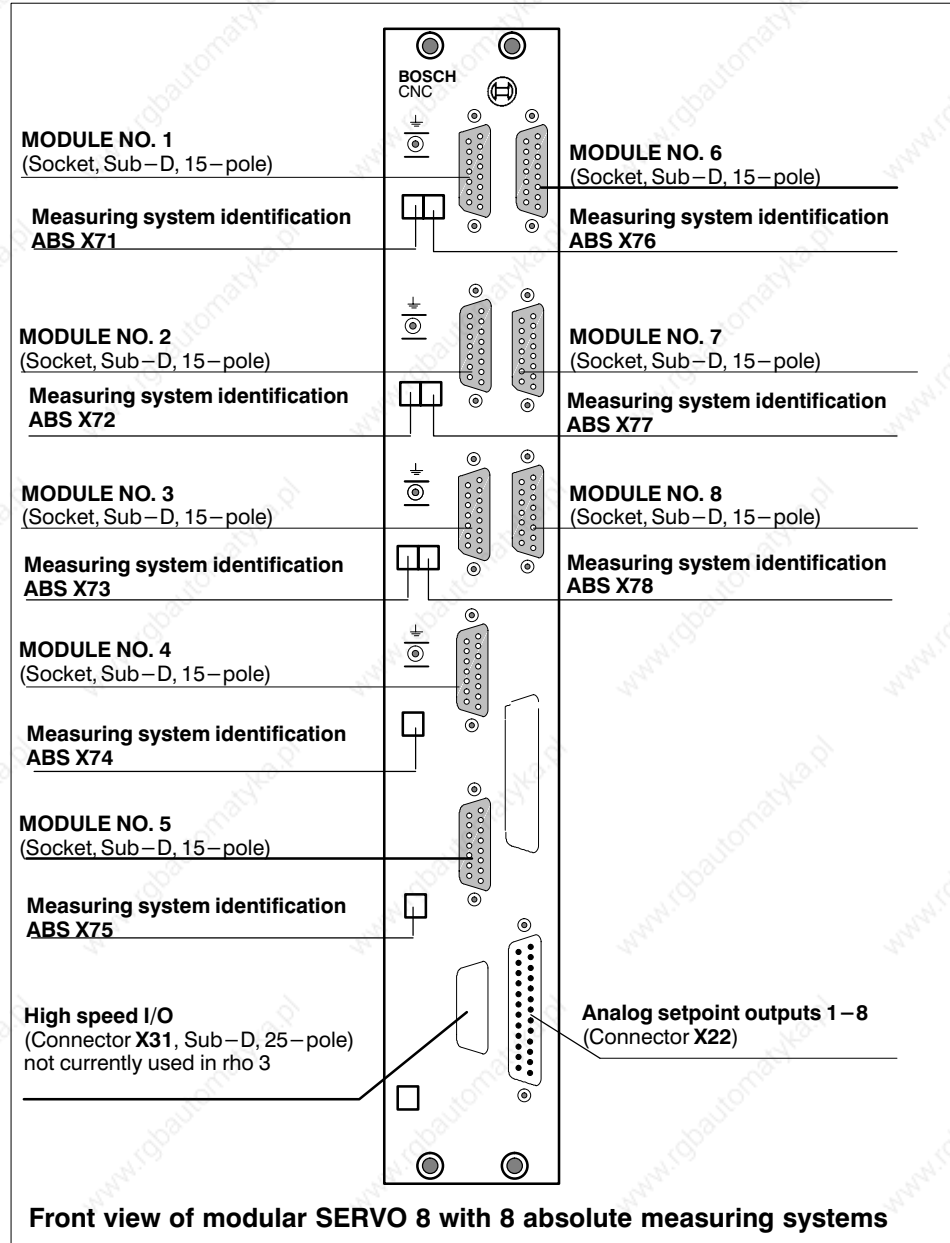

**3.7.2. Overview of modular Servo abs7/inc1**



**3.7.3. Overview of modular Servo abs5**

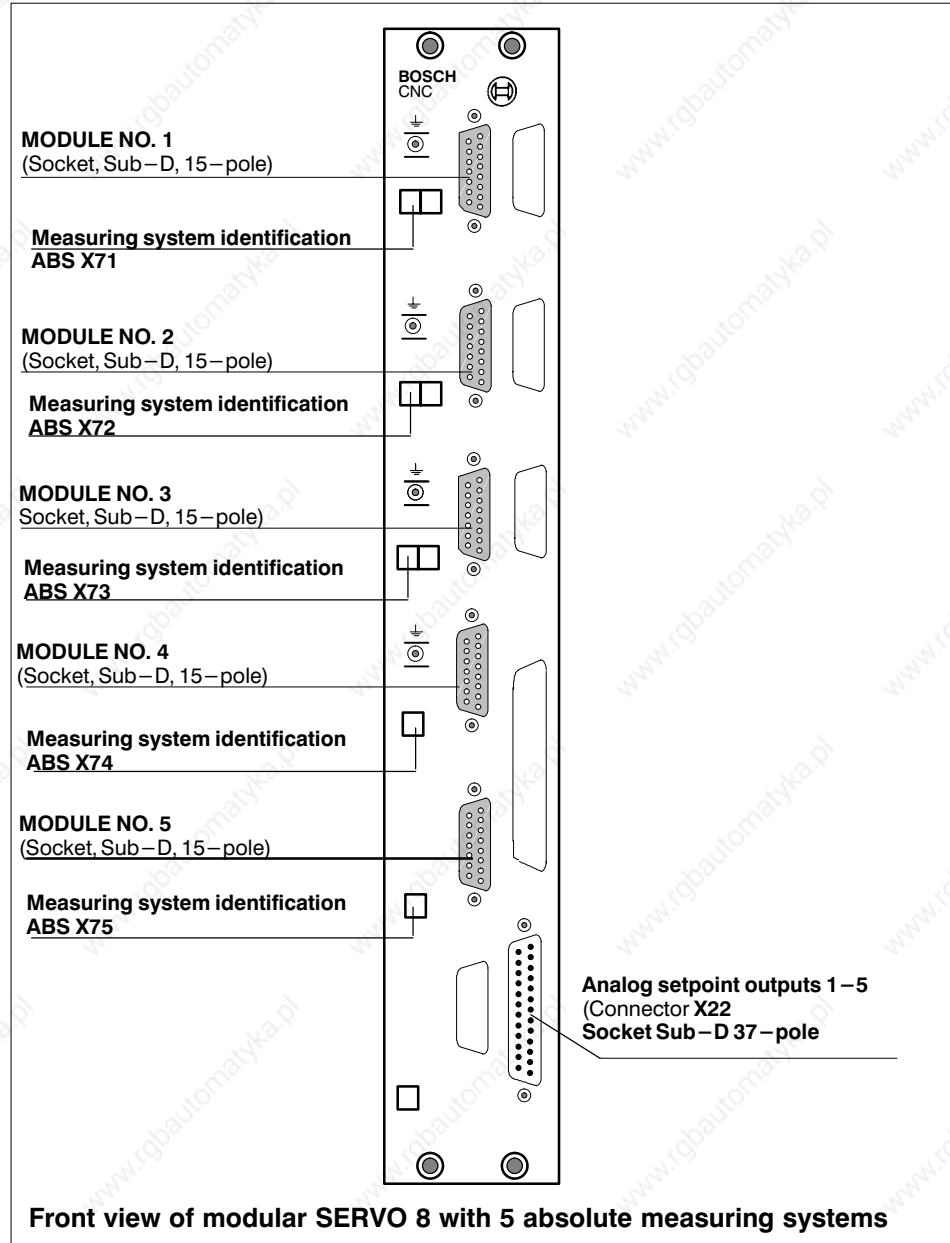

**3.7.4. Overview of modular Servo inc6/poti1**



**Caution:**

The servo card "modular SERVO" must be removed only when the control is switched off.

### 3.7.5. Incremental measuring system inputs

The following data applies generally to the incremental measuring system inputs:

- Max. permissible cable length/input: 50 m or manufacturer's specification
- Max. permissible cable length difference at all inputs: 15 m
- Cable type: Special cable NFS 7264  
10 x 0.14 mm<sup>2</sup> + 4 x 0.5 mm<sup>2</sup>  
(not for trailing operation!)
- Signal inputs: Differential line receiver  
Ri = 120 W Ω
- Input signals: A, B, R,  $\bar{A}$ ,  $\bar{B}$ ,  $\bar{R}$  (TTL level);  
min. voltage between A and  $\bar{A}$ , B and  $\bar{B}$ , R and  $\bar{R}$   $\geq$  600 mV
- Pulse multiplication: Quadruplication of the input frequency (four-edge evaluation)
- Max. permitted input frequency: 500 kHz
- Encoder/EXE power supply: +5 V (adjustable at PSU PS200)
- Max. permissible current consumption per encoder/EXE: 350 mA

The signal lines of the measuring systems must be connected exactly in accordance with these conditions. **It is not permitted to change around the signal lines for the purpose of direction reversal because this will lead to decoding of the zero pulse.** Direction reversal can be realized in the software by means of machine parameter **P308**.

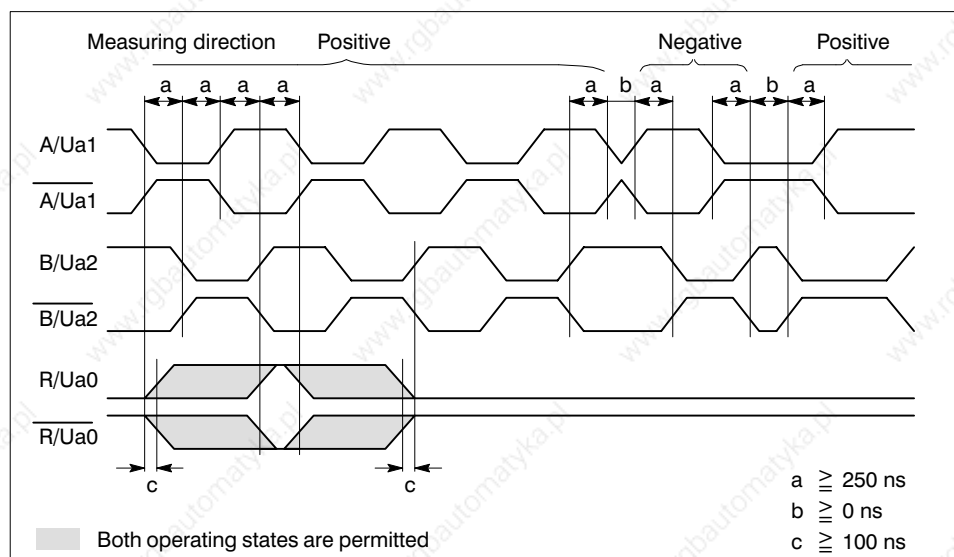



### 3.7.5.1. Approved incremental digital measuring

Measuring systems for direct connection or connection via a pulse shaper (EXE) are used. The interface condition of the manufacturer with respect to cable length and routing must be observed.

Power is supplied to a directly connected encoder or an EXE with external 5 V supply via the measuring system input socket.

Combinations from the ROD/LS and EXE product range from Messrs. Heidenhain must be adapted to the requirements of the machine and control in each case.

Rotary encoders for direct connection from Messrs. Heidenhain can be installed subject to the following preconditions:

- 5 V encoder power supply
- Square-wave signal output
- Line driver in accordance with RS 485
- Encoder current consumption < 350 mA
- Min. edge spacing between two active counting pulses  $\geq 250$  ns
- Min. edge spacing for direction reversal  $\geq 0$  ns
- Safety distance for reference signal  $\geq 100$  ns

In addition, it is possible to install EXEs from Messrs. Heidenhain if the following preconditions are satisfied:

- 5 V or external 220 V power supply
- Square-wave signal output
- Line drive in accordance with RS 485
- Max. encoder and EXE current consumption with 5 V supply: < 350 mA
- Min. edge spacing between active counting pulses  $\geq 250$  ns
- Min. edge spacing for direction reversal  $\geq 0$  ns
- Safety distance for reference signal  $\geq 100$  ns

#### Rotary measuring systems

- Rotary encoder for direct connection:
 

ROD 220 (Messrs. Heidenhain)	
ROD 420	"
ROD 426	"
ROD 428	"

#### Recommended rotary encoders for direct connection:

- |         |   |
|---------|---|
| ROD 428 | " |
|---------|---|
- Rotary encoders for connection via EXE 604 C, EXE 605 C:
 

ROD 250 (Messrs. Heidenhain)	
ROD 450	"
ROD 456	"
ROD 700	"
ROD 800	"
  - Rotary encoders for connection via EXE 702, EXE 816:
 

ROD 800 (Messrs. Heidenhain)	
------------------------------	--

### **Linear measuring systems**

- Linear scales for connection to  
EXE 604 C, EXE 605 C, EXE 610,  
EXE 801, EXE 802, EXE 803  
EXE 804, EXE 805, EXE 813:     LS 703 (Messrs. Heidenhain)  
   LS 707           ”  
   LS 903           ”
  
- Linear scales for connection to  
EXE 808, EXE 816:                 LS 300 (Messrs. Heidenhain)  
   LIDA 325          ”

### **Recommended electronic pulse shaper (EXE)**

Of the EXEs with external 5 V supply, we recommend the following:

- EXE 604 C (Messrs. Heidenhain)

However, EXEs with own 220 V power supply should be preferred.

### **Recommendation for electronic pulse shaper (EXE) and encoder**

We recommend using the EXE 604 C and encoder ROD 428. These types do not have any capacitive connection between 0 V of the supply voltage and the housing. This leads to higher interference immunity. In addition, these types possess an extended measuring system monitoring function which informs the Bosch control of errors by tri-state switching of the output signals.

The EXE 604 C was developed specially for Bosch controls. It corresponds to the EXE 601 and additionally possesses a ground stud as well as a 12-pole Souriau connector at the RC end.

### **Notes:**

- **The list of measuring systems should be considered only as a general recommendation owing to frequent technical modifications and increasing product priority.**
- Please enquire if it is wished to use other measuring systems.
- The encoder supply voltage must be adjusted so that the encoder supply voltage is +5 V +/- 5 % for all connected encoders and the permitted cable lengths (measured directly at the encoder input). The encoder supply voltage is set at the potentiometer  $V_{MS}$  of the power supply PS200.
- **The maximum permissible load of the measuring system supply voltage depends on the power supply module used and is a maximum of 3 A for the PS200 and a maximum of 1.5 A for the PS75.**
- The encoder cable from the RC control to the ROD encoder can be supplied by Bosch. This is equipped with a 15-pole Sub-D connector at the RC end and a 12-pole circular socket of the type "Souriau" at the encoder end. Preassembled encoder cables are available with length of 5 m, 8 m, 16 m, 25 m, 35 m or 50 m.
- If the ROD encoder is supplied by Bosch, its cable (0.5 m) is equipped with a circular connector of the type "Souriau".

☞ The error signal  $U_{as}$  is not evaluated by the SERVO 8. The EXEs 604 C and 605 C signal a measuring system error by tri-state switching of the output signals. If the EXEs 604 C and 605 C are not used, this means that any errors which occur in the area of the measuring system – EXE input cannot be detected! In this case, the user must take other suitable protective measures.

### 3.7.5.2. Pin assignments of incremental measuring systems

The cable screen must possess a continuous **connection** from the front panel of the servo card (screen terminal) to the measuring system.

☞ The connector pin assignment applies only to cables and encoders supplied by BOSCH

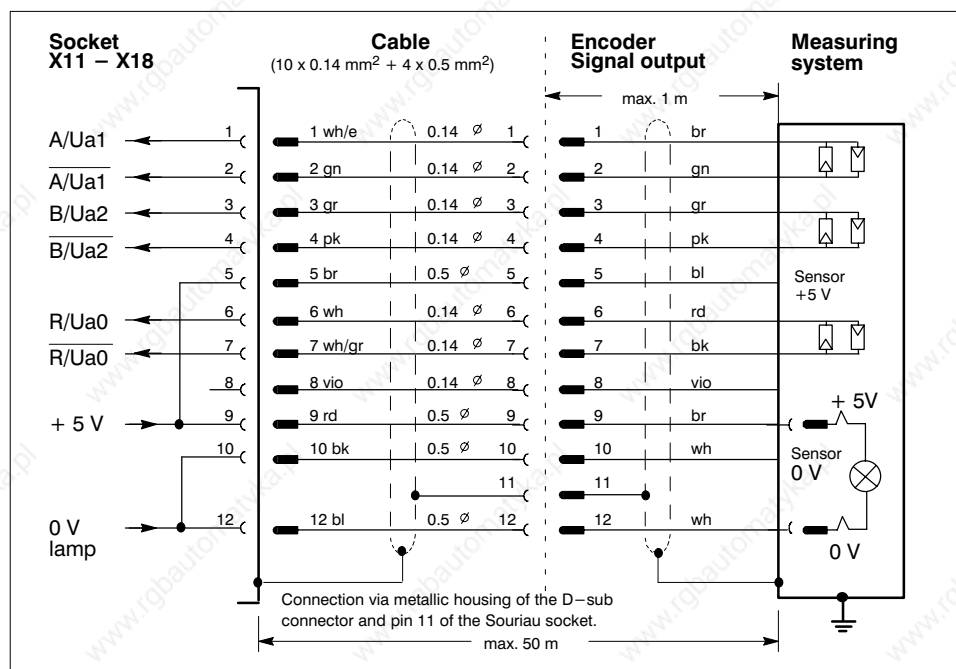

The connecting cables from EXE to the measuring system are cables from Messrs. Heidenhain.



**Cable: Servo – measuring system (ROD)**



**Pin assignment**

Color	Connector X11	Color	Socket X2
white–yellow	1	white–yellow	1
green	2	green	2
grey	3	grey	3
pink	4	pink	4
brown 0.5 □	5	brown 0.5 □	5
white	6	white	6
white–grey	7	white–grey	7
violet	8	violet	8
red 0.5 □	9	red 0.5 □	9
black 0.5 □	10	black 0.5 □	10
blue 0.5 □	12	blue 0.5 □	12
Screen	Connector housing	Screen	11

### 3.7.6. Absolute encoder module

The absolute encoder module permits connection of absolute encoders with synchronous serial interface (**SSI**). The module converts the serial data stream into parallel information and monitors data transfer and the connection to the connected measuring system.

The following monitoring functions are performed:

- Cable break monitoring** – Check of correct level before and after data transfer; **measuring system alarm** is signalled in the event of an error.
- Watchdog monitoring** – Conversion takes place cyclically and sets **measuring system error** in the event of an error
- Plausibility check** – If double transmission mode is active, the plausibility check function sets a measuring system error if double transmissions containing errors occur successively
- Supply voltage monitoring** – The absolute encoder monitors its supply voltage and sets a power failure flag in the serial data stream in the event of a voltage dip. The absolute encoder module generates a **measuring system alarm** from this.

#### Interface characteristics:

Max. permissible cable length      50 m for 24V encoders  
   35 m for 5V encoders

Max. permissible cable length difference with several encoders 10 m (for 5 V encoders)

Cable type: Special cable 2\*2\*0.5 mm<sup>2</sup> double screen 1\*2\*1.0 mm<sup>2</sup>

Resolution :                             16–bits per revolution  
   16–bits number of revolutions

Approved encoder types:             Stegmann AG 66 SSI  
   AG 110 SSI

The interface conditions and specifications of the encoder manufacturer must be observed and taken into account.

When ordering the encoder, the following information is required:

- Resolution per revolution
- Max. number of revolutions
- Coding of position information (grey, binary)
- Power supply (24 V or 5 V)

**It must be ensured that the encoder sets the POWER FAILURE BIT in the event of a voltage dip.**

**3.7.6.1. Pin assignment for absolute encoder module**



### 3.7.7. Potentiometer measuring system module

The potentiometer measuring system module permits connection of up to 12 potentiometers as measuring sensors, whereby a maximum of 8 of these measuring system inputs can be used as a position measuring system for controlled axes since a **maximum of 8** setpoint outputs are available on the modular Servo.

The Potentiometer measuring system module can also be used for connection of sensors which supply a DC voltage signal of + 10 V.

The module occupies two module slots located under each other on the modular Servo

○	technical data:	
	Permissible potentiometer resistance	10kOhm
	Potentiometer supply voltage	±10V + 1%
	Max. cable length	50m
	Min. cable cross-section	0,5 mm potentiometer supply 0.14 mm for slider
		connection
	Max. temperature increase of the cable	30°C
	Max. permissible rate of change of input voltage	± 20V/s Caution ! Incorrect function values may result if this value is exceeded.
	Max. internal resistance of the input voltage source	2,5kOhm
	Min. permissible external load resistance	10 MOhm
	Load resistance of the module	10 MOhm
	Conversion resolution	14 bits
	Increment voltage	1,22mV
	Number of input channels	12
	Linearity	0,01%
	Long-term stability, typical	± 0,5mV/1000h

Positive or negative full scale values ( $\pm 10$  V) are converted in the event of a short circuit or discontinuity in the measuring system circuit. The software monitors the function values of the individual input channels for 100 increments of the respective full scale value. A measuring system error is signalled in the event of an error. The monitoring area is lost to the working area. The slider wire is monitored for a short-circuit with respect to the two supply leads. There is no monitoring of the slider wire for discontinuity.





**3.7.7.1. Pin assignment for potentiometer module**





### 3.7.8. Analog setpoint outputs

Speed-proportional voltages for controlling the individual axes are available at these outputs.

---

 **An undefined output voltage may be output at the setpoint outputs of the modular SERVO when the control is switched off. For this reason, the load voltage must be switched off first and then the logic voltage when the control is switched off.**

---

In addition, the following points must be observed with respect to the analog setpoint outputs of the modular SERVO:

- Recommended cable type:
- The screen connection depends on the drives used (e.g. for Servodyn T: connection at both ends).
- Max. output range:  $\pm 13.3\text{ V}$
- Output voltage (rapid traverse):  $\pm 10\text{ V}$
- The output voltages are non-isolated.
- Permitted load resistance at output:  $\text{min. } 10\text{ k}\Omega$
- The output stages are resistant to sustained short circuits. However, if several outputs are short circuited, the output operational amplifier may be destroyed as a result of the increased power loss.
- The inputs at the drive amplifiers must be connected as a difference amplifier. Ground-bonded circuits must be avoided.

**3.7.8.1. Pin assignment OUT ANALOG X22**



### 3.8 Control Loop Card Modular SERVO m.i.

The control loop card Servo m.i. serves to output the analog speed nominal values and closes the position control circuit by evaluating the signals of the connected position measuring systems. The servo scanning rate is dependent on the machine parameter **P5**.

This card is equipped with its own processor module to reduce the interpolation and position control clock frequency.

The card has the hardware interface for **"fast inputs"**.

If incremental measuring systems are used, the hardware interface for **"fast measurement"** (probe) is also present on the card.

The modular servo card **SERVO m.i.** is available in a narrow version as:

**SERVO m.i. ABS3**

for 3 absolute measuring systems with 3 analog outputs for setpoint setting. This card only occupies one slot.

In the wide version, this card occupies two slots and can be fitted with the following modules on a modular principle:

<b>Incremental</b> module	one module per measuring system
<b>Absoluts</b> module	one module per measuring system
<b>Potentiometer</b> module	for up to 12 potentiometer measuring system. This module occupies 2 module slots.

The wide version is available in the configuration as:

**SERVO m.i. ABS4/INC1**

for four absolute and one incremental measuring system,

**SERVO m.i. ABS6/INC1**

for six absolute and one incremental measuring system,

**SERVO m.i. ABS8/INC1**

for eight absolute and one incremental measuring system,,

**SERVO m.i. ABS6/INC1/POTI**

for six absolute, one incremental

and one potentiometer module for connection of up to 12 potentiometer measuring systems,

and as

**SERVO m.i.ABS9** for nine absolute measuring systems.

Depending on the configuration, up to 10 analog outputs for setpoint output are present on the card.

Analog outputs that are not assigned to an axis can be used for other functions (see rho3 description of machine parameters and rho3 description of configuration options).

On the following pages, all necessary conditions for the selection of suitable measuring systems and their connection are described.

### 3.8.1 Identification of connections

All connections of the Servo m.i. are uniquely identified by a connector (socket) designation.

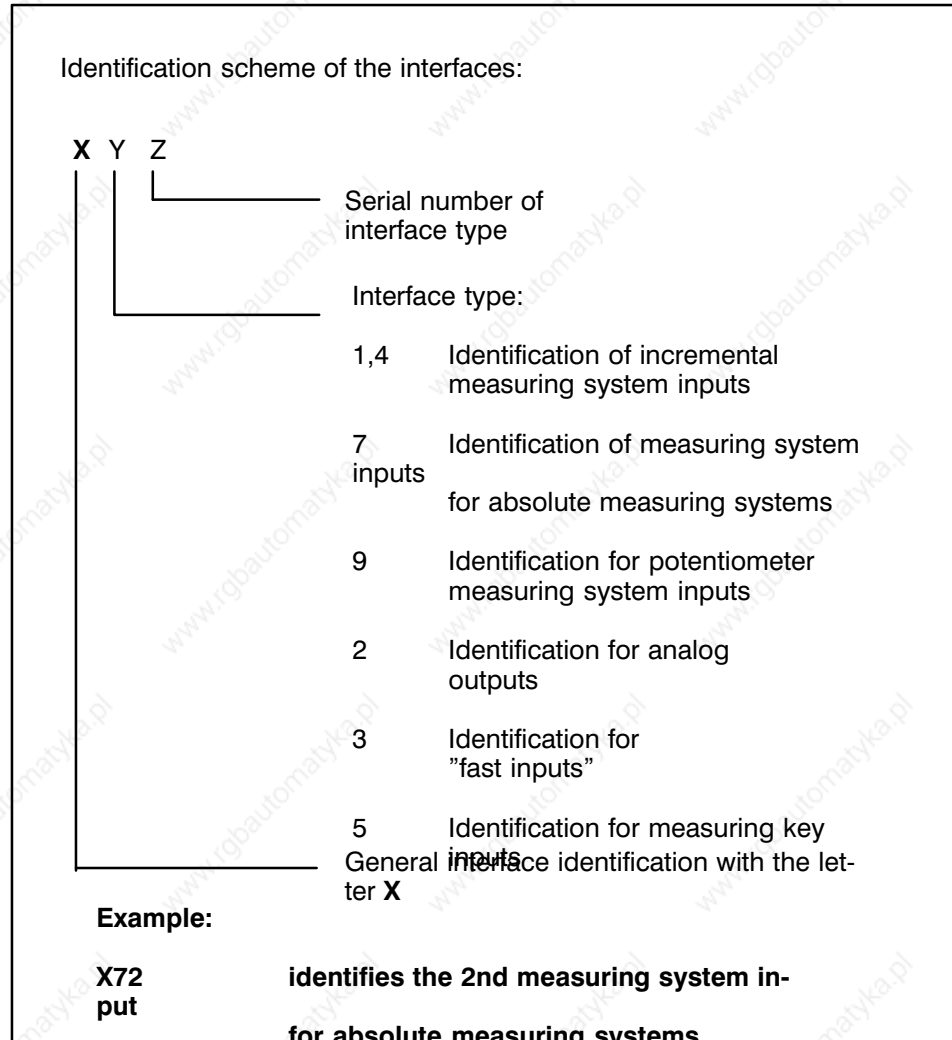

**3.8.2 Overview of SERVO m.i. ABS3**

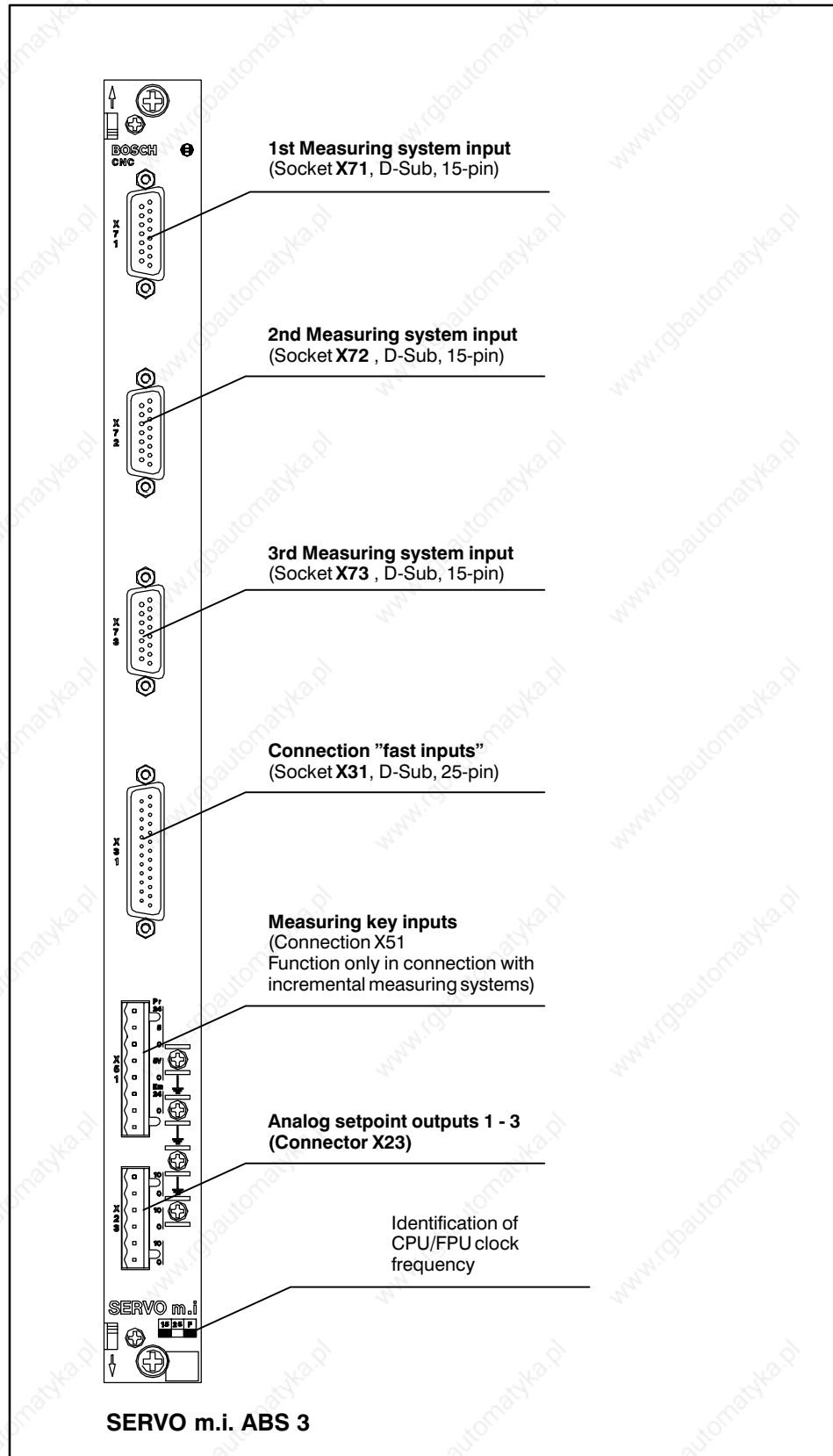

**3.8.3 Overview of SERVO m.i. ABS4/INC1**





**3.8.4 Overview of SERVO m.i. ABS6/INC1**



**3.8.5 Overview of SERVO m.i. ABS8/INC1**



**3.8.6 Overview of SERVO m.i. ABS9**

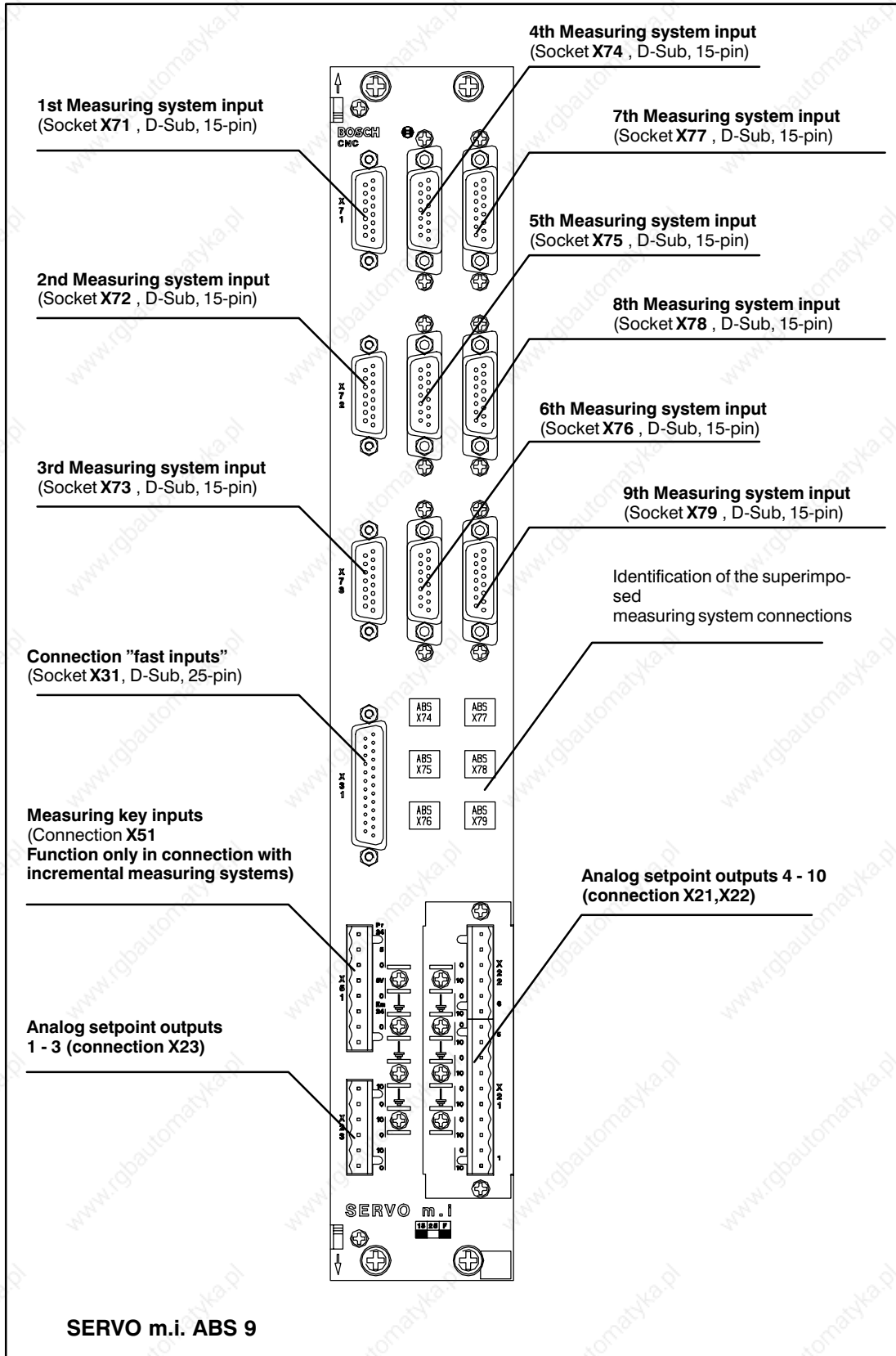

**3.8.7 Overview of SERVO m.i. ABS6/INC1/Potentiometer**

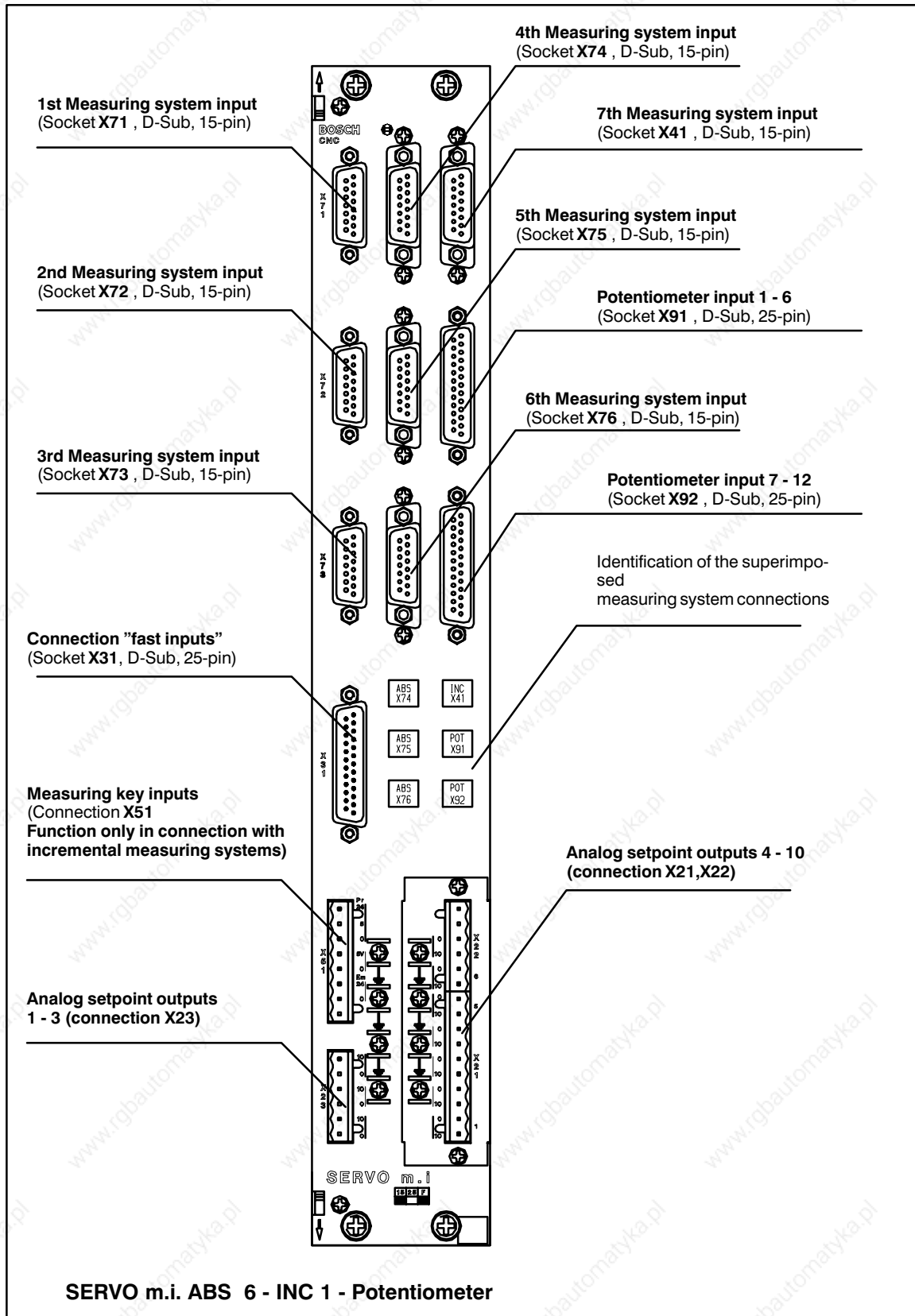

### 3.8.8 Incremental measuring system inputs

The following details apply in general for incremental measuring system inputs:

- Max. permitted cable length/input: 50 m when using voltage supply module PS200, or 30 m when using voltage supply module PS75.

**If the encoder manufacturer prescribes a lower value, this value is binding.**

- Max. permitted cable length difference at all inputs: 15 m
- Cable type: Special cable NFS 7264  
10 x 0.14 mm<sup>2</sup> + 4 x 0.5 mm<sup>2</sup>  
(not for trailing cable operation !)
- Signal inputs: Differential line receiver  
R<sub>i</sub> = 120 Ω
- Input signals: A, B, R,  $\bar{A}$ ,  $\bar{B}$ ,  $\bar{R}$  (TTL level);  
min. voltage difference between  
A and  $\bar{A}$ , B and  $\bar{B}$ , R and  $\bar{R}$  ≥ 600 mV
- Impulse multiplication: Quadrupling of input frequency  
(quad slope evaluation)
- Max. permissible input frequency: 800 kHz
- Encoder/EXE voltage supply: +5 V (adjustable at power supply module PS200)
- Max. permissible current consumption per encoder/EXE: 250 mA
- Max. permissible current consumption of all encoders and EXEs connected to one modular SERVO m.i.: 1.5 A

The signal lines of the measuring systems must be connected exactly in accordance with these connection conditions.

**Switching of the signal wires to change the direction is not permissible due to the coding of the reset pulse!**

A change of direction can be implemented with the software by means of machine parameter **P308**.

#### 3.8.8.1 Permissible incremental measuring systems

Measuring systems for direct connection or for connection via a pulse shaper (EXE) can be used. The connection conditions stipulated by the manufacturer for cable length and cable laying must be observed.

The power supply of a directly connected encoder or an EXE with an external 5V supply is implemented via the measuring system input socket.

The specific details of the ROD/LS and EXE proposal from the Heidenhain company must be adapted to the requirements of the machine and controller.

In general, rotary encoders for direct connection supplied by the companies Heidenhain and Stegmann can be fitted subject to the following conditions:

- 5V encoder power supply
  - Right-angled signal output
- Line driver conforming to RS485 or RS422
- Encoder power consumption < 250 mA
  - Min. edge interval between active counting pulses  $\geq 250$  ns
  - Min. edge interval in rotation direction reversal  $\geq 0$  ns
  - Reliability interval for reference signal  $\geq 100$  ns

EXEs from the Heidenhain company can also be fitted subject to the following conditions:

- 5V or external 230V power supply
  - Right-angled signal output
- Line driver conforming to RS485 or RS422
- Max. encoder and EXE power consumption for 5V supply: < 350 mA
- Min. edge interval between active counting pulses  $\geq 250$  ns
  - Min. edge interval in rotation direction reversal  $\geq 0$  ns
  - Reliability interval for reference signal  $\geq 100$  ns

Signal to time diagram

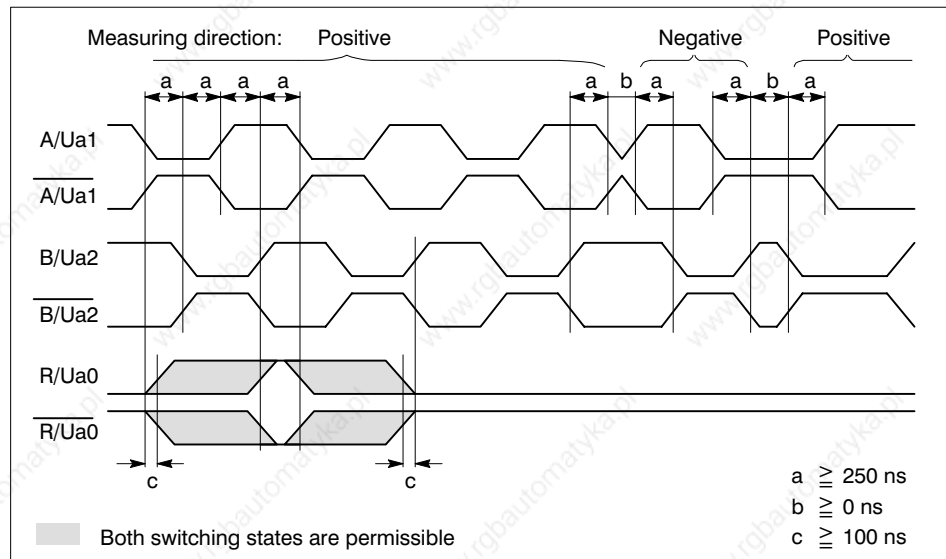

### 3.8.8.2 Rotary measuring systems

If the ROD encoder is supplied by Bosch, its cable (0.5 m) is fitted with a round plug of the "Souriau" type. The encoder cable from RCY controllers to the ROD encoder can be supplied by Bosch fully assembled in the lengths 5m, 8m, 16m, 25m, 35m or 50m. At the RCY end it contains a 15-pole D-SUB connector, and at the encoder end it contains a 12-pole "Souriau" round socket.

- Rotary encoder for direct connection                      ROD 220 (Heidenhain company).

ROD 420                      "  
ROD426                      "  
ROD 428                      "  
DG 60 (Stegmann company).  
DG 90 D                      "  
DG 100 D                      "

**Recommended rotary encoder for direct connection:**

ROD 428  
DG 60 D

- Rotary encoder for connection via  
EXE 604 C, EXE 605 C: ROD 250 (Heidenhain company).

ROD 450                      "  
ROD 456                      "  
ROD 700                      "  
ROD 800                      "

- Rotary encoder for connection via  
EXE 702, EXE 816:                      ROD 800 (Heidenhain company).

### 3.8.8.3 Linear measuring systems

- Linear measuring systems for direct connection:  
LS 323 (Heidenhain company).  
LS 623                      "

- Linear scales for connection via  
EXE 604 C, EXE 605 C, EXE 610,  
EXE 801, EXE 802, EXE 803,  
EXE 804, EXE 805, EXE 813:                      LS 403 (Heidenhain company).  
LS 703                      "  
LS 707                      "  
LS 903                      "

- Linear scales for connection via  
EXE 808, EXE 816:                      LS 300 (Heidenhain company).  
LIDA 325                      "

**Interval-coded measuring systems**

- Rotary encoder:                      TE 60 (Stegmann company).
- Linear scales:                      LIP 101 A  
LS xxx C (Heidenhain company).

### 3.8.8.4 Recommended pulse shaper electronics (EXE)

Of the available EXEs with an external 5V supply, we recommend:

- EXE 604 C (Heidenhain company).

It is preferable, however, to use EXEs with their own 230V power supply.

#### **Recommendation for pulse shaper electronics (EXE) and encoder**

We recommend the use of EXE 604 C and the encoder ROD 428. These types have no capacitive connection between 0V of the power supply and the housing. This provides a reduced susceptibility to interference. Furthermore, these types have an extended measuring system monitoring capacity which reports to the Bosch controller any errors caused by tristate switching of the output signals.

EXE 604 C was specially developed for Bosch controllers. It corresponds to EXE 601, and in addition it has an earthing pin and, at the RCY end, a 12-pole Souriau-type connector.

#### **Notes:**

- **Due to the frequency of alterations and the increasing number of types, the list of measuring systems can only be a general recommendation.**
- Other measuring systems are available on request.
- The encoder supply voltage must be set so that for all encoders connected, and the permissible cable lengths, the encoder supply voltage is +5V +/-5% (directly at the encoder input).  
When using the PS200, the encoder supply voltage is adjusted in the potentiometer  $V_{MS}$  of the power supply module.
- **The maximum permissible load placed on the measuring system supply voltage by all encoders and EXEs connected to the controller is dependent on the voltage supply module used; for the PS200 it is a maximum of 3A, for the PS75 a maximum of 1.5A.**
- The encoder cable from RCY controllers to the ROD encoder can be supplied by Bosch. At the RCY end it contains a 15-pole D-SUB connector, and at the encoder end it contains a 12-pole "Souriau" round socket. Completely assembled encoder cables can be supplied in the lengths 5 m, 8 m, 16 m, 25 m, 35 m or 50 m.
- If the ROD encoder is supplied by Bosch, its cable (0.5 m) is fitted with a round plug of the "Souriau" type.

---

 **The incremental measuring system module does not evaluate the error signal Uas. EXEs 604 C and 605 C report a measuring system error by tristate switching of the output signal. If EXEs 640 C and 605 C are not used, errors that occur in the area of the measuring system - EXE input can not be detected! In this case, the user must implement other suitable protective measures!**

---



### 3.8.8.5 Connection assignment for incremental measuring systems

The cable shield must have a **continuous** connection from the front panel of the servo card (screen connections) to the measuring system.

**Rotary encoder from Heidenhain company.**

**The pin assignment only applies to cables and encoders supplied by Bosch**



**Rotary encoder from Stegmann company.**

**The pin assignment only applies to cables and encoders supplied by Bosch**

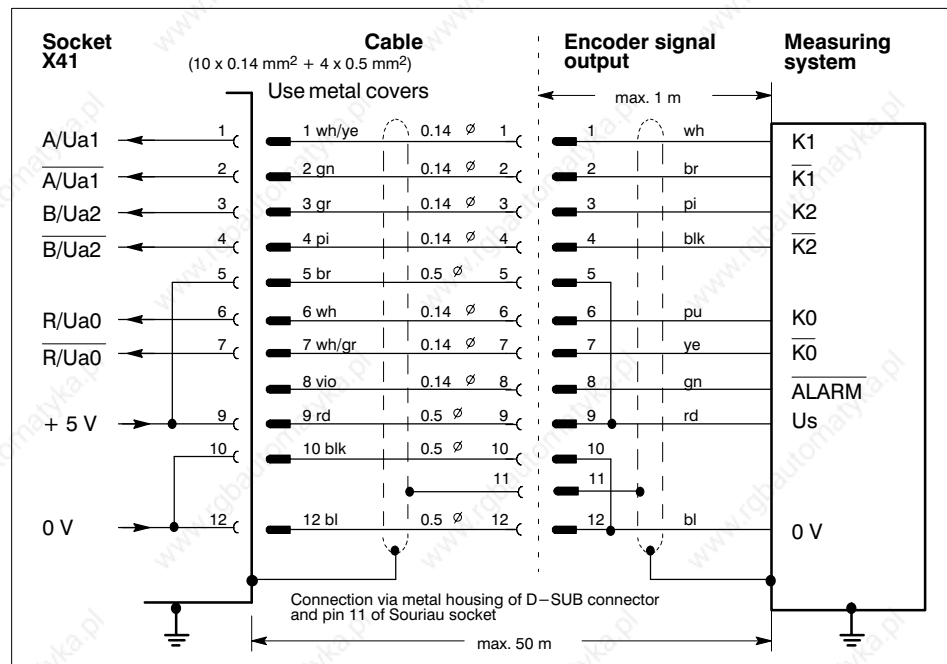

**NOTE:**

When using the BOSCH cable, only the housing form "1" with a cable tail of 0.5 m is permissible for the encoder. A 12-pin "Souriau" type round connector must then be fitted to the encoder **by the user**.

**Rotary encoder from the Heidenhain company with pulse shaper electronics (EXE)**  
The connection cables from EXE to the measuring system are cables supplied by the Heidenhain company.

☞ **The pin assignment only applies to cables and EXEs supplied by Bosch**

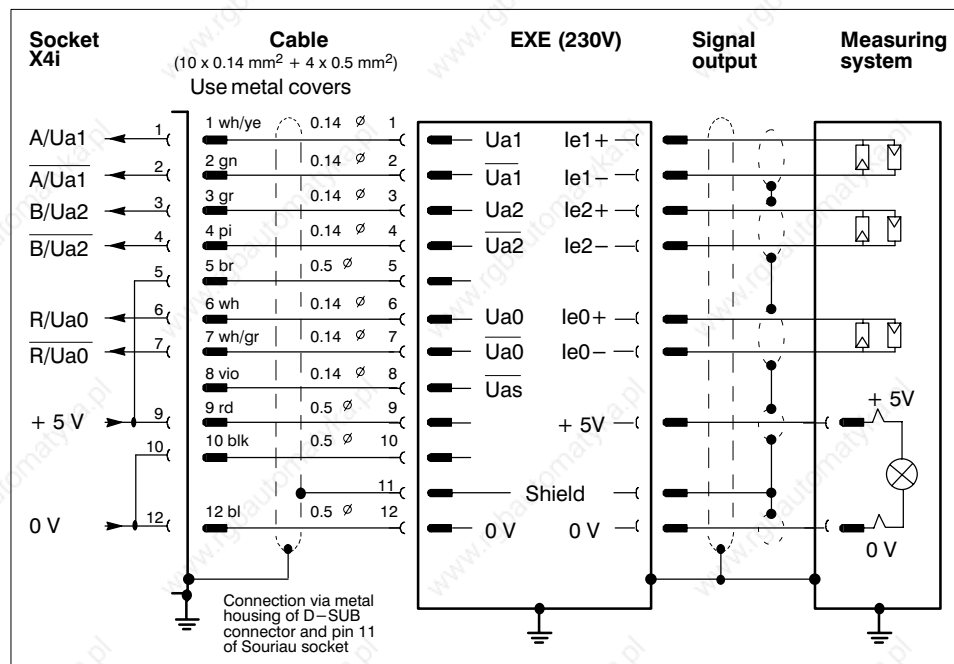
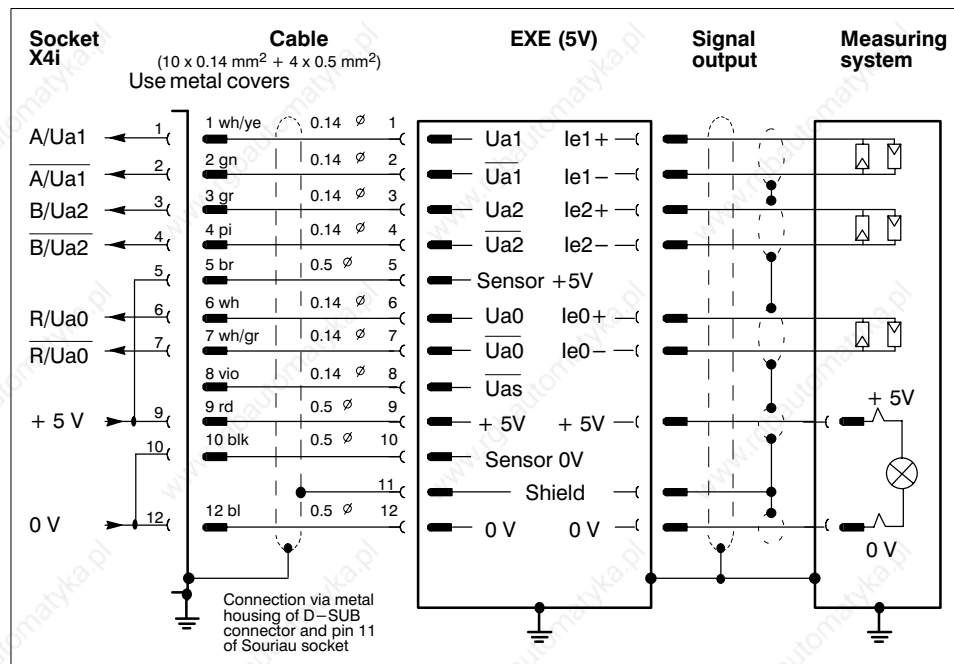

### 3.8.8.6 Cable Servo measuring system (ROD)



#### Pin assignment

Color	D-SUB connector X4i	Souriau socket
white-yellow	1	1
green	2	2
grey	3	3
pink	4	4
brown 0.5 <sup>2</sup>	5	5
white	6	6
white-grey	7	7
violet	8	8
red 0.5 <sup>2</sup>	9	9
black 0.5 <sup>2</sup>	10	10
blue 0.5 <sup>2</sup>	12	12
Shield	Connector housing	11

#### Ordering information

Type	No.
Ready-assembled cable length 5 m	048 662
Ready-assembled cable length 8 m	048 663
Ready-assembled cable length 16 m	048 664
Ready-assembled cable length 25 m	048 665
Ready-assembled cable length 35 m	048 666
Ready-assembled cable length 50 m	048 667
Single parts:	
Cable 10 x 0.14 + 4 x 0.5 <sup>2</sup>	903 499
D-connector, 15-pin. Pin904 440	
Metal cover for 15-pin D connector.	913 724
Socket 12 pin, Souriau909 131	
Accessory kit for Souriau socket	909 688

### 3.8.9 Absolute encoder module

(Terminals X71 to X79)

The absolute encoder module permits the connection of absolute encoders with a synchronous serial interface (**SSI**). The module converts the serial data flow into parallel information and monitors the transmission and link to the connected measuring system. The following checks are carried out:

- Cable breakage check -** Checks before and after a transmission for correct level; In the event of an error a **measuring system alarm** is reported
- Watchdog check -** Conversion proceeds cyclically, and in the event of an error it reports a **measuring system error**
- Plausibility check -** If dual transmission is activated, a measuring system error is set by the plausibility test if defective dual transmissions occur one after the other
- Supply voltage check -** the absolute encoder monitors its supply voltage, when there is a voltage fall, the encoder sets a power failure identifier in the serial data stream. The absolute encoder module then creates a **measuring system alarm**

#### 3.8.9.1 Interface characteristics of absolute measuring systems

<b>Max. permitted cable length:</b>	180 m
<b>Cable type</b> :	Special cable 2*2*0.5 mm <sup>2</sup> , double shielded 1*2*1.0 mm <sup>2</sup>
<b>Interface</b> :	Synchronous serial (SSI)
<b>Data input</b> :	TTL-compatible signals DATA and $\overline{\text{DATA}}$ from differential line drivers to EIA 422A
<b>Pulse output</b> :	TTL-compatible signals PULSE and $\overline{\text{PULSE}}$ from differential line drivers
<b>Pulse frequency</b> :	125kHz
<b>Number of pulses</b> :	In dual transmission 28 for single turn encoders 52 for multi-turn encoders  In single transmission 14 for single turn encoders 26 for multi-turn encoders
<b>Time between two transmissions:</b>	>35 $\mu$ s

### 3.8.9.2 Permissible absolute measuring systems

Encoders can be used which fulfil the characteristics stipulated,

e.g. Stegmann AG 66 SSI  
AG 110 SSI

Only encoders should be used which permit a dual transmission for the plausibility check of the measured value.

The supply voltage for the encoders is not provided by the modular Servo m. i.s. We recommend the use of encoders with a 24 V supply voltage. The 24 V logic voltage can be used to supply the encoders. If a different voltage source is used, its 0 V must be linked to the 0 V of the logic voltage.

**If the supply voltage fails, the encoders must set a power failure bit in accordance with the transmission format in order to detect incorrect measured values.**

Encoder characteristics:

Resolution per revolution	:	max. 4096 steps/360°
Number of revolutions	:	1 for single turn max. 4096 for multi–turn
Code:	:	Gray or binary

**Transmission format:**

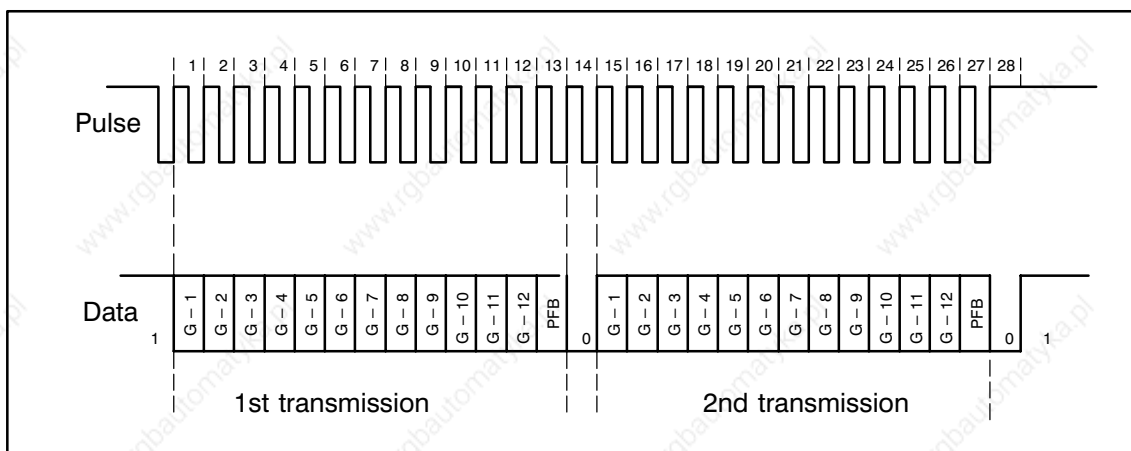

Fig. 1 Data telegram, single turn encoder

In Fig. 1 the illustration NO FLAG, the data word for a single turn encoder is represented with a resolution of 4096 increments /360°. For lower resolutions, the unused lower value bits (. . . ,G-11,G-12 ) must be transmitted as '0'. In single transmission, the data word ends with the 14th pulse.

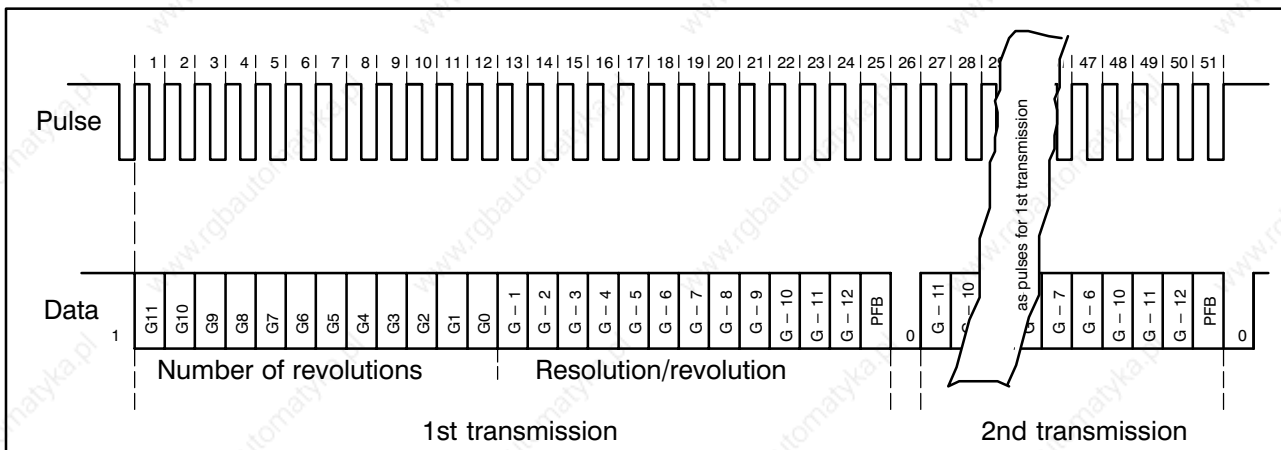

Fig. 2 Data telegram multi-turn encoder

Fig. 2 shows the structure of the data word for a multi-turn encoder with a resolution of 4096 revolutions and 4096 increments/360°.

For lower resolutions, the unused higher value bits (G<sub>11</sub>, G<sub>10</sub>...) and the unused lower value bits (...G<sub>-11</sub>, G<sub>-12</sub>) must be transmitted as '0'. In single transmission, the transmission of a data word ends with pulse 26.



Fig. 3 Time diagram for both encoders (single and multi-turn encoder)

- T** = 8 μs is pre-set by the controller
- t<sub>1</sub>** < 0.5 μs (directly at the encoder)
- 12 μs < **t<sub>2</sub>** < 35 μs
- G<sub>11</sub>** : highest value data bit (MSB)
- G<sub>-12</sub>** : lowest value data bit (LSB)
- PFB** : power failure bit (in case of an error = '1')

The connection conditions of the encoder manufacturer must be observed and adhered to.

The following data must be taken into account when selecting an encoder:

- Resolution per revolution
- Max. number of revolutions
- Coding of the path information (Gray or binary)
- Power failure bit as the last data bit (when a voltage failure occurs)
- Power supply 24V

### 3.8.9.3 Pin assignment for absolute encoder module



Fig. 4 Pin assignment for absolute encoder module



### 3.8.10 Potentiometer measuring system module

( Terminals X91 and X92 )

The potentiometer measuring system module permits the connection of up to 12 potentiometers as measured result recorders. A **maximum of 10** of these measuring system inputs can be used as position measuring systems for controlled axes, as a maximum of 10 setpoint outputs are present on the modular servo card.

The potentiometer measuring system module can also be used for the connection of sensors that provide a direct current signal of  $\pm 10V$ .

The module occupies two module slots situated one below the other.

#### Technical data:

<input type="radio"/>	Permissible potentiometer resistance	10kOhm
<input type="radio"/>	Potentiometer supply voltage	$\pm 10V + 1\%$
<input type="radio"/>	Max. cable length	50m
<input type="radio"/>	Min. cable cross section	0.5 mm <sup>2</sup> for potentiometer supply 0.14mm <sup>2</sup> for slider connection
<input type="radio"/>	Max. temperature rise of cable	30°C
<input type="radio"/>	Max. permissible alteration speed of input voltage	$\pm 20mV/ms$ Caution ! Exceeding this value can cause incorrect functional values.
<input type="radio"/>	Max. internal resistance of input voltage source	2.5kOhm
<input type="radio"/>	Min. permissible external load resistance	10 MOhm
<input type="radio"/>	Load resistance of the module	10 MOhm
<input type="radio"/>	Conversion resolution	14 Bit
<input type="radio"/>	Incremental voltage	1.22mV
<input type="radio"/>	Number of input channels	12
<input type="radio"/>	Linearity	0.01%
<input type="radio"/>	Long-term stability, typical value	$\pm 0.5mV/1000h$

If there is a short circuit or an interruption in the measuring system circuit, the positive or negative final value ( $\pm 10V$ ) is converted. The software monitors the functional values of the individual input channels up to 100 increments from the relevant final value. If an error occurs, a measuring system error is reported.

The supervision area is not available for the working area.

**The slider circuit is monitored for short circuits to the two supply circuits. The slider circuit is not monitored for interruptions.**



Fig. 5

### 3.8.10.1 Pin assignment for potentiometer module



Fig. 6



Fig. 7

### 3.8.11 Analog setpoint outputs

(Terminals X21, X22 and X23)

At these outputs, speed–proportional voltages are available for accessing the individual axes.

Folgendes ist für die Analog-Sollwertausgänge der Servo m.i. zu beachten:

- Recommended cable type: Belden 2 x 0.5 mm<sup>2</sup> (8762-20)
- Max. cable length: 50m
- The shield connection is dependent on the drives used (e.g. for Servodyn T: connection on both sides).
- Max. output voltage range: + /-13.3 V
- Incremental voltage (setpoint): 0.400 mV
- Output voltage (fast mode): +(-)10 V
- The output voltages are linked to potential.
- Permissible load resistance at the output min. 10 kΩ
- The output levels are permanently short–circuit–protected. However, if several outputs are short circuited, the higher loss performance may cause the destruction of the output operational amplifiers.
- The inputs of the drive amplifiers must be connected as differential amplifiers. Ground–linked circuits must be avoided.
- If the READY signal goes to LOW, the setpoint outputs are immediately set to 0 V (analog GND). This level is kept constant for a minimum of 1 sec. Therefore, the drives must be switched off **within 1 sec.**

**3.8.11.1 Pin assignment analog outputs**



### 3.8.12 Fast inputs

#### Connection (connector X31)

#### General remarks

The inputs of connector X31 are used in the rho 3 controller in the configuration levels "fast measuring" and "fast constant starting". Further information on these functions can be found in the document "rho 3 configuration level description", P.No. 4268, article No. 073077, and the document "rho3 Description of machine parameters", P.No. 4262, article No. 073027.

#### 3.8.12.1 Technical data, fast inputs

The following data must be taken into account for the "fast inputs" of the SERVO m.i.:

- The input signals must be free from radio interference and bounce.
- Input voltage range: -3 V to +32 V
- All inputs are galvanically isolated from the logic voltage by optical couplers.
- Voltage threshold for transition from LOW to HIGH level: +8.5 V, +/-1 V
- Hysteresis for transition from HIGH to LOW level: 1 V, +/-0.5 V
- An open input is recognized as "logically 0".
- Input current/ input: max. 8 mA, +/-1 mA
- Shielded cables must be used.

#### Outputs

The outputs of X31 are currently not used with the rho 3 controller. The output levels are not defined. They can be 0V or 24V.

**3.8.12.2 Pin assignment, fast inputs**



**Voltage supply**

The voltage supply is implemented via connector X31 in accordance with the pin assignment. The voltage source is the 24 V load voltage with the characteristics given in the chapter on voltages and tolerances.

### 3.8.13 Probe inputs / 5V probe switching voltage

#### (Connector X51)

Connector X51 has two inputs (24 V DC, 5 V DC) for switching probes (label on front panel: "Pr"). Internally, the two inputs are linked via an OR function.

An additional switching voltage for a 5V probe is also available (load capacity: max. 10 mA). This voltage can be switched by the switching contact of a probe and returned to the controller at the 5 V DC probe input.

The inputs of connector X51 are used in the rho 3 controller in the configuration level "fast measuring".

Further information on this function can be found in document "rho 3 configuration level description", P.No. 4268, article No. 073077, and in document "rho3 description of machine parameters", P.No. 4262, article No. 073027.

The probe inputs are only used in connection with incremental measuring systems.

#### 3.8.13.1 Technical data, probe inputs

The following general points must be taken into account for the probe inputs of the SERVO i:

- The input signals must be free from radio interference and bounce. .
- Shielded cables must be used.
- An open input is detected as "logically 0".
- All inputs are galvanically isolated from the logic voltage by optical couplers.

##### 24 V probe input

- Max. permissible input voltage: +32 V
- HIGH level: +17 to +32 V
- LOW level: -3 bis +5 V (or open input)
- Rated input current (at 24 V): 8 mA
- Typical switching threshold: +12 V

##### 5 V probe input

- Max. permissible input voltage: +6 V
- HIGH level: +4 to +6 V
- LOW-Pegel: -3 to +0.8 V (or open input)
- Rated input current (at 5 V): 8 mA
- Typical switching threshold: +3 V



**3.8.13.2 Pin assignment, probe inputs**

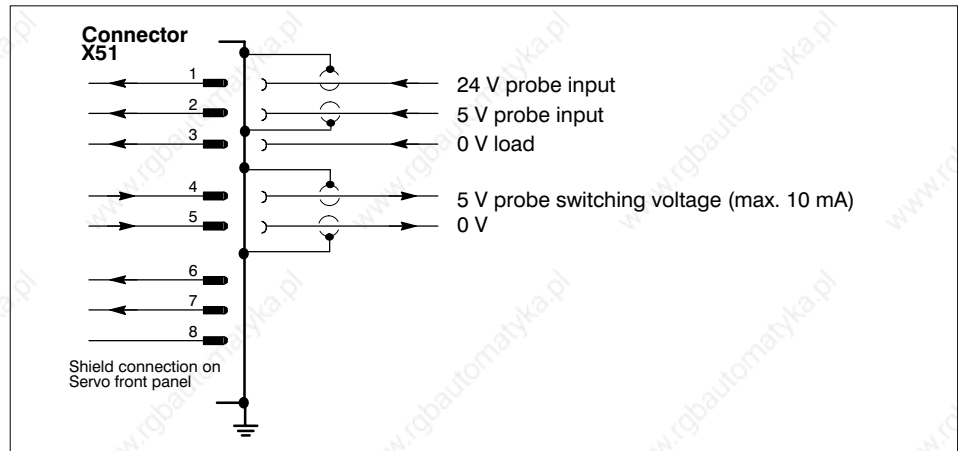

**3.8.13.3 Connection options for probes**

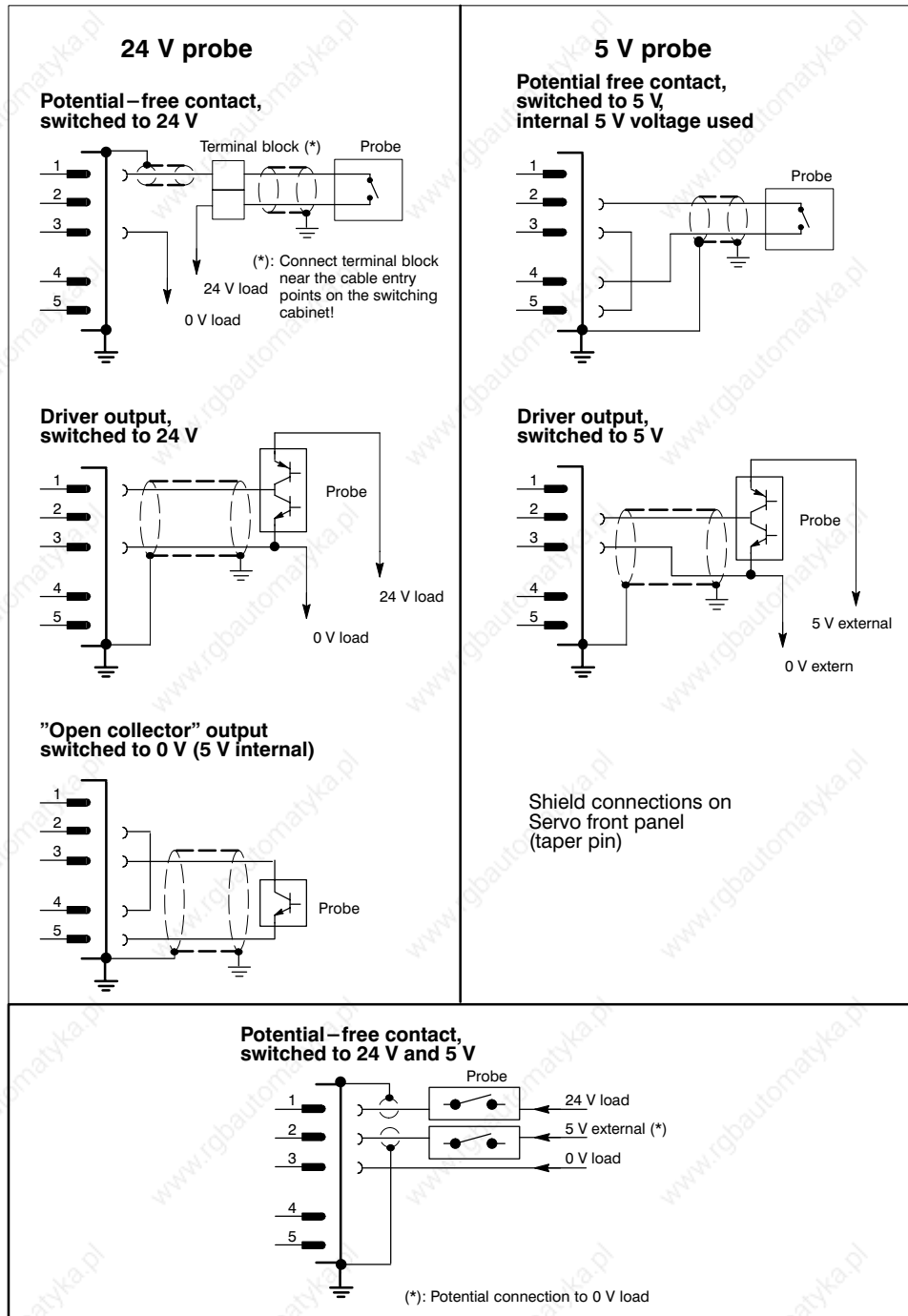

## 3.9. Servo interface SERVO i

### 3.9.1. Overview

The servo card is used for output of the analog speed setpoints and closes the position servo loop by evaluation of the signals of the connected incremental position measuring systems.

The Servo i card is offered in various hardware versions which differ with respect to the number of measuring system inputs and setpoint outputs.

#### **Servo 6i**

6 measuring system inputs  
7 analog setpoint outputs

#### **Servo 4i**

4 measuring system inputs  
4 analog setpoint outputs

#### **Servo 3i**

3 measuring system inputs  
3 analog setpoint outputs

The following descriptions refer to the Servo 6i. The details also apply to the Servo 4i and Servo 3i subject to the corresponding hardware restrictions.



### 3.9.2. Measuring system inputs

(Sockets X11 to X16) (X14 to X16 optional)

Both encoders for direct connection and encoders for electronic pulse shaper (EXE) can be connected to the measuring system inputs. The connection instructions of the manufacturers with respect to cable length and cable routing must be observed here. The power supply of a directly connected encoder or an EXE with external 5 V supply is also provided via the measuring system input socket.

The following data applies generally to the SERVO i measuring system inputs:

- Max. permissible cable length/input: 50 m or manufacturer specification
- Max. permissible cable length difference at all input: 15 m
- Cable type: Special cable NFS 7264  
10 x 0.14 mm<sup>2</sup> + 4 x 0.5 mm<sup>2</sup>  
(not for trailing operation!)
- Signal inputs: Differential line receiver  
 $R_i = 120 \Omega$
- Input signals: A, B, R,  $\overline{U_{as}}$ ,  $\overline{A}$ ,  $\overline{B}$ ,  $\overline{R}$   
(min. voltage difference between A and  $\overline{A}$ , B and  $\overline{B}$ , R and  $\overline{R} \geq 600 \text{ mV}$ )
- Pulse multiplication: Quadruplication of the input frequency (4-edge evaluation)
- Max. permissible input frequency: 500 kHz
- Encoder/EXE power supply: +5 V
- Max. total current consumption of all connected encoders/EXEs: 1.5 A

The signal lines of the measuring systems must be connected exactly in accordance with these conditions. **It is not permitted to change round the signal lines for the purpose of direct reversal because this one lead to decoding of the zero pulse!** Direction reversal can be realized in the software by means of the machine parameters.



### 3.9.2.1. Approved digital measuring systems

Rotary encoders for direct connection for Messrs. Heidenhain and Stegmann can be installed if they satisfy the following preconditions:

- 5 V encoder power supply
- Square-wave signal output
- Line driver in accordance with RS 485
- Encoder current consumption < 250 mA
- Min. edge spacing between active counting pulses  $\geq 250 \text{ ns}$

In addition, EXEs from Messrs. Heidenhain which satisfy the following preconditions can be installed:

- 5 V or external 220 V power supply
- Square-wave signal output
- Line drive in accordance with RS 485
- Max. encoder and EXE current consumption with 5 V supply: < 350 mA
- Min. edge spacing between active counting pulses  $\geq 250 \text{ ns}$

#### Rotary measuring systems

- Rotary encoder for direct connection:
 

ROD 220 (Messrs. Heidenhain)	
ROD 420	"
ROD 426	"
ROD 428	"
DG 60 D (Messrs. Stegmann)	
DG 90 D	"
DG 100 D	"

#### Recommended rotary encoders for direct connection:

ROD 428  
DG 60

- Rotary encoders for connection via EXE 604 C, EXE 605 C: ROD 250 (Messrs. Heidenhain)  
ROD 450 "

ROD 456       ”  
ROD 700       ”  
ROD 800       ”

- Rotary encoder for connection via EXE 702, EXE 816:       ROD 800 (Messrs. Heidenhain)

**Linear measuring systems**

- Linear scales for connection to EXE 604 C, EXE 605 C, EXE 610, EXE 801, EXE 802, EXE 803, EXE 804, EXE 805, EXE 813:       LS 703 (Messrs. Heidenhain)  
LS 707       ”  
LS 903       ”

- Linear scales for connection to EXE 808, EXE 816:       LS 300 (Messrs. Heidenhain)  
LIDA 325       ”

**Recommended electronic pulse shaper (EXE)**

Of the EXEs with external 5 V supply, we recommend the following:

- EXE 604 C (Messrs. Heidenhain)

However, EXEs with own 220 V power supply should be preferred.

**Notes:**

- The list of measuring systems should be considered only as a general recommendation owing to frequent technical modifications and increasing product priority.
- Please enquire if it is wished to use other measuring systems.
- In the case of rotary encoders with direct connection or EXEs, it is recommended to use such types which do not have any capacitive connection between 0 V or the supply voltage and the housing (e.g. ROD 428, EXE 604 C). This improves immunity to interference.
- The SERVO i detects a measuring system error both through the input signal Uas and when the connected encoders/EXEs switch their output stages to tri-state condition (high-resistance).
- Non-driven Uas lines are connected to inactive potential by pull-up resistors on the SERVO i.



### 3.9.2.2. Pin assignments

The cable screen must possess a **continuous connection** from the front panel of the SERVO i (screen terminals) to the measuring system.

#### Heidenhain rotary encoders

**The connector pin assignment applies only to cables and encoders supplied by BOSCH**



**Stegmann rotary encoders**

**The connector pin assignment applies only to cables and encoders supplied by BOSCH**



**Heidenhain rotary encoders with electronic pulse shaper (EXE)**

The connecting cables from the EXE to the measuring system are Heidenhain cables.

**The connector pin assignment applies only to cables and EXEs supplied by BOSCH**

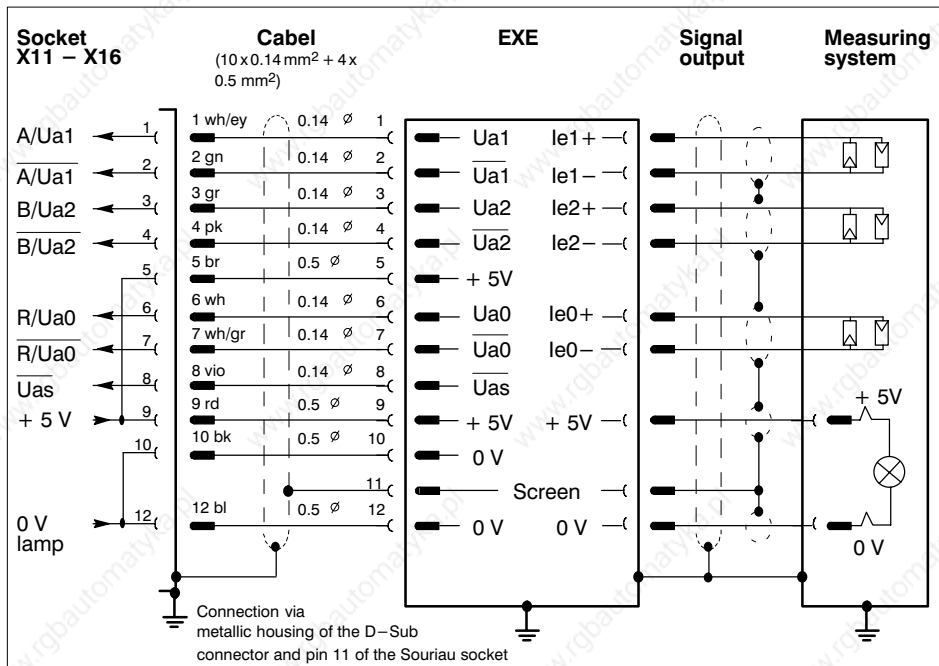

**Cable: Servo – measuring system (ROD)**



**Pin assignment**

Farbe	Stecker X11	Farbe	Buchse X2
white–yellow	1	white–yellow	1
green	2	green	2
grey	3	grey	3
pink	4	pink	4
brown 0.5 □	5	brown 0.5 □	5
white	6	white	6
white–grey	7	white–grey	7
violet	8	violet	8
red 0.5 □	9	red 0.5 □	9
black 0.5 □	10	black 0.5 □	10
blue 0.5 □	12	blue 0.5 □	12
Screen	Connector housing	Screen	11

**Ordering data**

Type	No.
Cable ... 10 x 0,14 + 4 x 0,5 □	903 499
D–connector, 15–pole male	904 440
Metal cover for 15–pole D–connector	913 724
Socket 12–pole Souriau	909 131
Accessory set for Souriau socket	909 688
Preassembled cable, cable length 5 m	048 663
Preassembled cable, cable length 8 m	048 663
Preassembled cable, cable length 16 m	048 664
Preassembled cable, cable length 25 m	048 665
Preassembled cable, cable length 35 m	048 666
Preassembled cable, cable length 50 m	048 667

### 3.9.3. Analog setpoint outputs

(Connectors 21 and X22)

Speed-proportional voltages are available at these outputs for controlling the individual axes.

The following points must be taken into account with respect to the analog setpoint outputs of the Servo i:

- Recommended cable type: Belden 2 x 0.5 mm<sup>2</sup> (8762-20)
- The screen connection depends on the drives used (e.g. for Servodyn T: connection at both ends) .
- Max. output voltage range: +/- 13.3 V
- Increment voltage (nom.): 406 µV
- Output voltage (rapid traverse): +(-)10 V
- The output voltages are non-isolated.
- Permissible load resistance at output: min. 10 kΩ
- The output stages are resistant to sustained short circuits. However, if several outputs are short-circuited, the output operational amplifier may be destroyed as a result of the increased power loss.
- The setpoint outputs are immediately set to 0 V (analog GND) if the READY signal goes LOW. This level is kept constant for a maximum of 1 s. The drives **must** be switched off during this time
- The inputs at the drive amplifiers must be connected as difference amplifiers. Ground-bonded circuits must be avoided.

**3.9.3.1. Pin assignment**



### 3.9.4. Fast inputs

#### Connection (connector X31)

#### General remarks

The inputs of connector X31 are used in the rho 3 controller in the configuration levels "fast measuring" and "fast constant starting". Further information on these functions can be found in the document "rho 3 configuration level description", P.No. 4268, article No. 073077, and the document "rho3 Description of machine parameters", P.No. 4262, article No. 073027.

#### 3.9.4.1. Technical data, fast inputs

The following data must be taken into account for the "fast inputs" of the SERVO m.i.:

- The input signals must be free from radio interference and bounce.
- Input voltage range: -3 V to +32 V
- All inputs are galvanically isolated from the logic voltage by optical couplers.
- Voltage threshold for transition from LOW to HIGH level: +8.5 V, +/-1 V
- Hysteresis for transition from HIGH to LOW level: 1 V, +/-0.5 V
- An open input is recognized as "logically 0".
- Input current/ input: max. 8 mA, +/-1 mA
- Shielded cables must be used.

#### Outputs

The outputs of X31 are currently not used with the rho 3 controller. The output levels are not defined. They can be 0V or 24V.

### 3.9.4.2. Pin assignment, fast inputs



#### Voltage supply

The voltage supply is implemented via connector X31 in accordance with the pin assignment. The voltage source is the 24 V load voltage with the characteristics given in the chapter on voltages and tolerances.



### 3.9.5. Probe inputs / 5V probe switching voltage

#### (Connector X31)

Connector X31 has two inputs (24 V DC, 5 V DC) for switching probes (label on front panel: "Pr"). Internally, the two inputs are linked via an OR function.

An additional switching voltage for a 5V probe is also available (load capacity: max. 10 mA). This voltage can be switched by the switching contact of a probe and returned to the controller at the 5 V DC probe input.

The inputs of connector X31 are used in the rho 3 controller in the configuration level "fast measuring".

Further information on this function can be found in document "rho 3 software Releases", article No. 073077, and in document "rho3 description of machine parameters", article No. 073027.

#### 3.9.5.1. Technical data, probe inputs

The following general points must be taken into account for the probe inputs of the SERVO :

- The input signals must be free from radio interference and bounce. .
- Shielded cables must be used.
- An open input is detected as "logically 0".
- All inputs are galvanically isolated from the logic voltage by optical couplers.

#### 24 V probe input

- Max. permissible input voltage: +32 V
- HIGH level: +17 to +32 V
- LOW level: -3 bis +5 V (or open input)
- Rated input current (at 24 V): 8 mA
- Typical switching threshold: +12 V

#### 5 V probe input

- Max. permissible input voltage: +6 V
- HIGH level: +4 to +6 V
- LOW-Pegel: -3 to +0.8 V (or open input)
- Rated input current (at 5 V): 8 mA
- Typical switching threshold: +3 V

**3.9.5.2. Pin assignment, probe inputs**

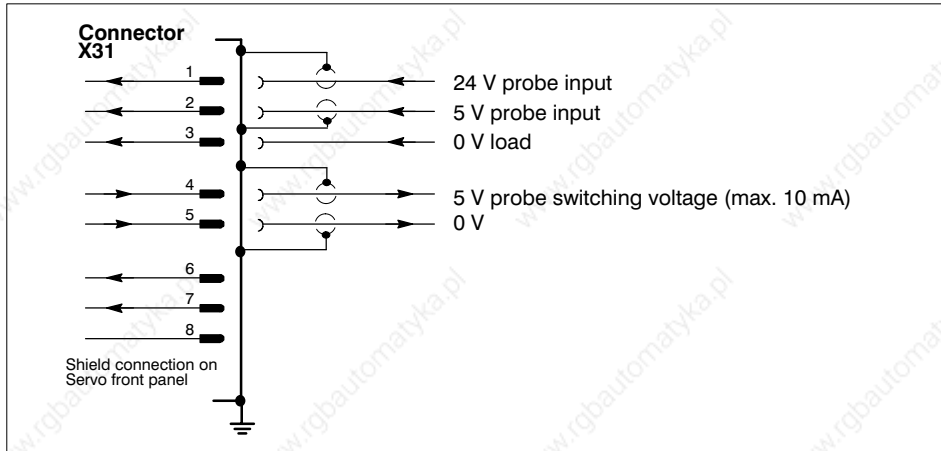

**3.9.5.3. Connection options for probes**

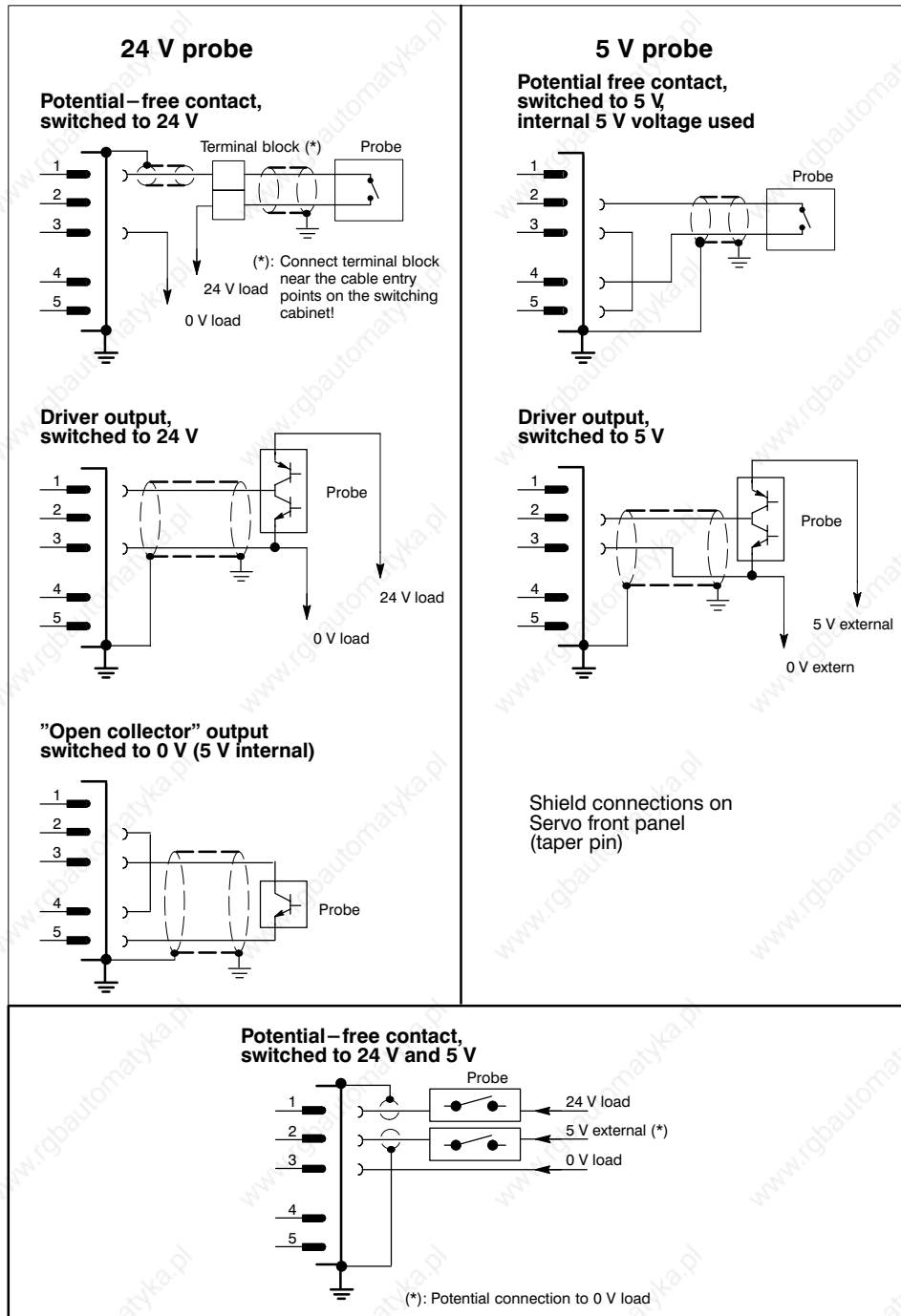

### 3.10 Modulo I/O 24/0.1 with PIC250

#### Digital I/O with integrated PLC PIC250

60 inputs and 40 outputs are available for machine and interface purposes.

A second I/O 24/0.1 module (without integrated PIC) can be installed in order to increase the number of inputs/outputs. 128 inputs and 80 outputs are then available as machine signals.

The PIC250 is a PLC which functions parallel to the RC and which can be plugged onto the I/O 24/0.1 module as a separate auxiliary card.



**Caution:**

The module must be removed only when the RC is **switched off**.

**Data of the PIC 250:**

1024 digital inputs                                8 times        1024 markers  
 1024 digital outputs        8 counters  
 Max. 8 k memory (EEPROM)  
 The processing speed is 10 ms for an 8 kB PIC program  
 The RC interface can be addressed via the PIC addresses  
 A0.0 to A88.7 (RC inputs) and  
 E0.0 to E88.7 (RC outputs).

Further information is contained in the manual rho 3 signal description and **rho 3 description of machine parameters**.

**Write protection PIC 250**

Position 0:  
 Access to the PIC program is possible (editing, deletion).  
 However, it is only possible to edit a PIC program which is **not** active.

Position 1:  
 PIC 250 memory is protected against write access.

**Caution:**

The write protection must be activated (position 1) after the PIC program is put into operation. If this is not done, the PIC memory may be overwritten and the PIC program lost.

**Supply voltage (connection X10)**

The 24 V supply must be provided via a transformer in accordance with VDE 0551. The 24 V supply is separate from the 24 V voltage supply for the NC power supply.

Incoming supply 24 V =; (plug-in terminal, 4-pole). Polarized supply voltage input for the digital outputs at X11. Maximum input current: 4 A.

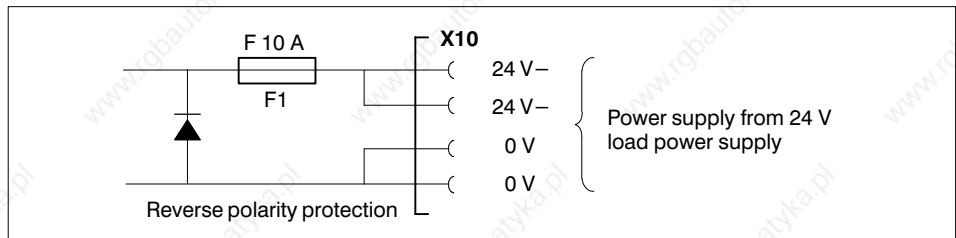

**Digital outputs (connection X11)** (Socket, Sub-D, 50-pole)

These outputs are freely assignable. The signal assignment depends on the PLC program. 40 outputs are available ( $I_{out}$ : max. 0.1 A per output). The assignment between PLC addresses and output pins is shown in the following table:

ADR	PIN	ADR	PIN	ADR	PIN	ADR	PIN	ADR	PIN	ADR	PIN	ADR	PIN	ADR	PIN
88.0	27	88.1	50	88.2	09	88.3	33	88.4	26	88.5	17	88.6	08	88.7	49
89.0	25	89.1	16	89.2	07	89.3	32	89.4	23	89.5	15	89.6	06	89.7	48
90.0	22	90.1	14	90.2	05	90.3	31	90.4	21	90.5	13	90.6	04	90.7	30
91.0	20	91.1	12	91.2	03	91.3	29	91.4	36	91.5	11	91.6	02	91.7	28
92.0	19	92.1	10	92.2	01	92.3	47	92.4	18	92.5	34	92.6	35	92.7	37

X11

**Digital outputs (Connection X11) with second I/O card**

ADR	PIN	ADR	PIN	ADR	PIN	ADR	PIN	ADR	PIN	ADR	PIN	ADR	PIN	ADR	PIN
93.0	27	93.1	50	93.2	09	93.3	33	93.4	26	93.5	17	93.6	08	93.7	49
94.0	25	94.1	16	94.2	07	94.3	32	94.4	23	94.5	15	94.6	06	94.7	48
95.0	22	95.1	14	95.2	05	95.3	31	95.4	21	95.5	13	95.6	04	95.7	30
96.0	20	96.1	12	96.2	03	96.3	29	96.4	36	96.5	11	96.6	02	96.7	28
97.0	19	97.1	10	97.2	01	97.3	47	97.4	18	97.5	34	97.6	35	97.7	37

X11

**Digital inputs (connections X21 and X22)** (X21: connector, Sub-D, 15-pole; X22: Connector, Sub-D, 50-pole)

The inputs are interrogated by the internal PLC (PIC 250). They are freely assignable. The signal assignments depends on the PLC program. 64 inputs are available.

The assignment between PLC addresses and input pins is shown in the following table:

ADR	PIN	ADR	PIN	ADR	PIN	ADR	PIN	ADR	PIN	ADR	PIN	ADR	PIN	ADR	PIN
88.0	48	88.1	47	88.2	50	88.3	49	88.4	33	88.5	32	88.6	17	88.7	16
89.0	46	89.1	15	89.2	31	89.3	45	89.4	30	89.5	14	89.6	29	89.7	44
90.0	13	90.1	12	90.2	28	90.3	43	90.4	11	90.5	27	90.6	42	90.7	10
91.0	26	91.1	41	91.2	09	91.3	25	91.4	24	91.5	08	91.6	40	91.7	07
92.0	23	92.1	39	92.2	06	92.3	22	92.4	38	92.5	05	92.6	21	92.7	04
93.0	37	93.1	20	93.2	03	93.3	36	93.4	19	93.5	02	93.6	01	93.7	18
94.0	34	94.1	35	94.2	15	94.3	07	94.4	14	94.5	06	94.6	13	94.7	05
95.0	12	95.1	04	95.2	11	95.3	03	95.4	10	95.5	02	95.6	09	95.7	01

X22

X21

**Digital inputs (Connectors X21 and X22)**(X21: Connector, Sub-D, 15-pole; X22: Connector, Sub-D, 50-pole)

ADR	PIN	ADR	PIN	ADR	PIN	ADR	PIN	ADR	PIN	ADR	PIN	ADR	PIN	ADR	PIN
96.0	48	96.1	47	96.2	50	96.3	49	96.4	33	96.5	32	96.6	17	96.7	16
97.0	46	97.1	15	97.2	31	97.3	45	97.4	30	97.5	14	97.6	29	97.7	44
98.0	13	98.1	12	98.2	28	98.3	43	98.4	11	98.5	27	98.6	42	98.7	10
99.0	26	99.1	41	99.2	09	99.3	25	99.4	24	99.5	08	99.6	40	99.7	07
100.0	23	100.1	39	100.2	06	100.3	22	100.4	38	100.5	05	100.6	21	100.7	04
101.0	37	101.1	20	101.2	03	101.3	36	101.4	19	101.5	02	101.6	01	101.7	18
102.0	34	102.1	35	102.2	15	102.3	07	102.4	14	102.5	06	102.6	13	102.7	05
103.0	12	103.1	04	103.2	11	103.3	03	103.4	10	103.5	02	103.6	09	103.7	01

X22

X21

**Interface cable**

**X11 (PIC 250 output signals)**



**Pin assignment**

Color	Connector	Color	Connector	Color	Conn.
white	1	grey-brown	18	green-black	35
brown	2	white-pink	19	yellow-black	36
green	3	pink-brown	20	green-blue	37
yellow	4	white-blue	21	pink-blue	38
grey	5	brown-blue	22	grey-red	39
pink	6	white-red	23	pink-red	40
blue	7	brown-red	24	grey-black	41
red	8	white-black	25	pink-black	42
black	9	brown-black	26	blue-black	43
violet	10	grey-green	27	red-black	44
grey-pink	11	Yellow-grey	28	white-brown-black	45
red-blue	12	pink-green	29	yellow-green-black	46
white-green	13	yellow-pink	30	grey.pink-black	47
brown-green	14	green-blue	31	red-blue-black	48
white-yellow	15	yellow-blue	32	white-green-black	49
yellow-brown	16	green-red	33	brown-green-black	50
white-grey	17	yellow-red	34		

**X21 (PIC 250 input signals)**



**Socket assignment**

Color	Connector
white	1
brown	2
green	3
yellow	4
grey	5
pink	6
blue	7
red	8
black	9
violet	10
grey-pink	11
red-blue	12
white-green	13
brown-green	14
white-yellow	15



**X22 (PIC 250 input signals)**

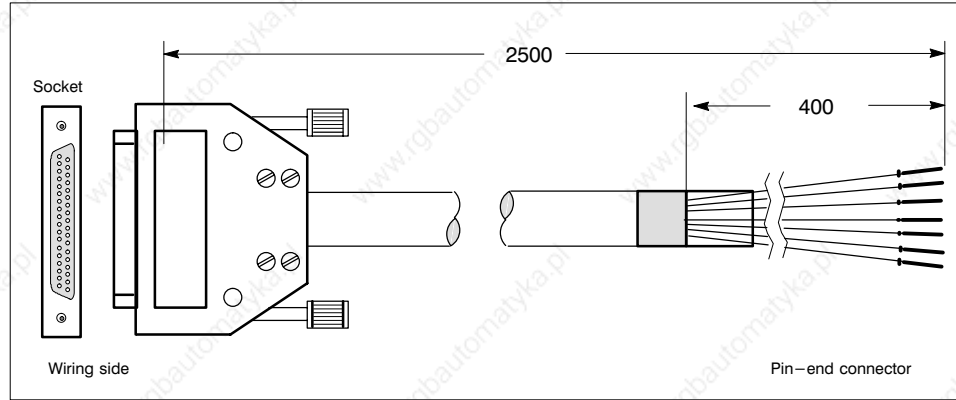

**Pin assignment**

Color	Connector	Color	Connector	Color	Conn.
white	1	grey-brown	18	green-black	35
brown	2	white-pink	19	yellow-black	36
green	3	pink-brown	20	green-blue	37
yellow	4	white-blue	21	pink-blue	38
grey	5	brown-blue	22	grey-red	39
pink	6	white-red	23	pink-red	40
blue	7	brown-red	24	grey-black	41
red	8	white-black	25	pink-black	42
black	9	brown-black	26	blue-black	43
violet	10	grey-green	27	red-black	44
grey-pink	11	Yellow-grey	28	white-brown-black	45
red-blue	12	pink-green	29	yellow-green-black	46
white-green	13	yellow-pink	30	grey.pink-black	47
brown-green	14	green-blue	31	red-blue-black	48
white-yellow	15	yellow-blue	32	white-green-black	49
yellow-brown	16	green-red	33	brown-green-black	50
white-grey	17	yellow-red	34		

**3.11 Input/Output Module I/O-32/16 0.5-A**

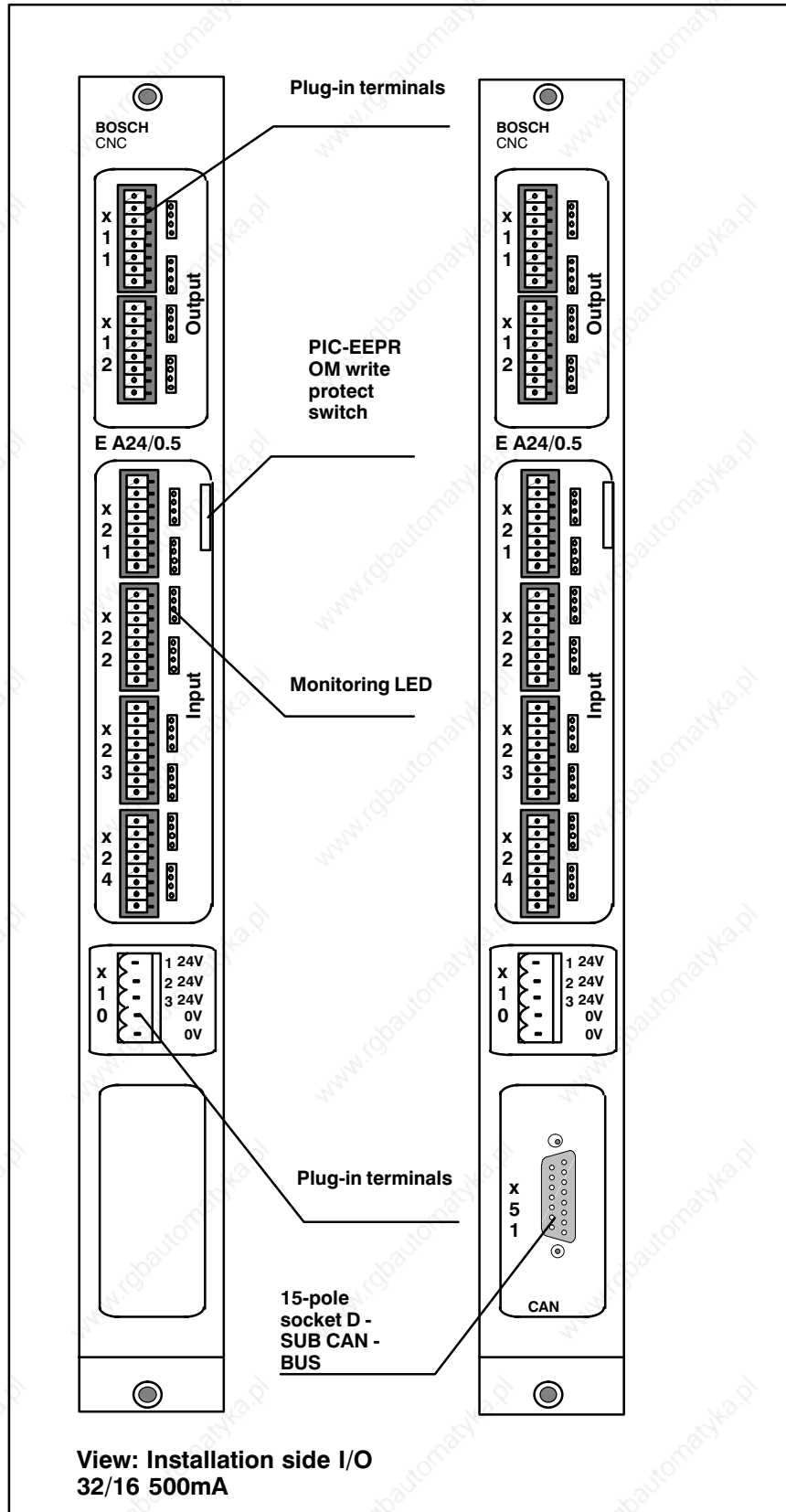

### 3.11.1 Power Supply

#### CONNECTOR X10

The power supply is 24 Volt +30%/ 15%.

The overall maximum nominal current consumption for a nominal voltage (24 V) and a nominal load is 8.7 amperes.

Under nominal conditions, the current consumption is distributed between the individual terminals (X10/1 to X10/3) as follows:

24V (X10/1)	0.8 amperes
24V (X10/2)	3.7 amperes
24V (X10/3)	4.2 amperes

These three terminals are **separate** power supply lines, so that if one power supply line fails, the corresponding part of the outputs no longer functions.

Each of the three power supply lines is fused with 6.3 A.

### 3.11.2 Inputs

#### CONNECTORS X21,X22,X23,X24

The maximum permissible input voltage range is between 3 volts and 31.2 volts.

An input is detected as HIGH from 15 volts upwards.

Up to 10 volts input voltage, the input is regarded as LOW.

The input current per input in the permissible range for HIGH is a minimum of 1 mA and a maximum of 15 mA (effective value, as the inputs are scanned). A light emitting diode is assigned to each input. It shows the logical status of the input. The internal supply voltage for the inputs is derived from the 24V (1).

#### NOTE:

**Even if the 24V is missing (X10/1), the light emitting diodes may light up when signals are received at the inputs. The display does not guarantee that the RC recognizes the input correctly (e.g. missing 24V (X10/1)).**

The inputs are protected with suppressor diodes. They serve the function of limiting transient voltage peaks (switching peaks). The nominal limitation voltage is approximately 60V. The current flow at that point is in the mA range. Larger currents (in the ampere range) can be conducted, but this means that a higher voltage briefly occurs in the diode. If a voltage greater than 60V is applied statically, and if the current flowing through the suppressor diode is greater than 10 mA, the diode may be destroyed. First, the diode forms a short circuit. However, if the current flow persists, depending on the magnitude of the current flowing in the case of a short circuit, the short circuit created by the suppressor diode may melt away again (diode evaporates).

The inputs are distributed to the addresses as follows:

Input	1 – 8	(Connector X21) to E88.0 E88.7
Input	9 – 16	(Connector X22) to E89.0 E89.7
Input	17 – 24	(Connector X23) to E90.0 E90.7
Input	25 – 32	(Connector X24) to E91.0 E91.7

For diagnostic purposes, the outputs (X11 and X12) are internally - directly - routed back to inputs. This enables the actual and nominal output status to be compared.

**The output status that has just been set can only be read in in the next PLC cycle.**

(Output 1-8)	Input E-92.0- -E-92.7
(Output 9-16)	Input E-93.0- -E-93.7

The voltage monitoring units check the three 24 V power supplies. The actuation thresholds lie between less than 13 volts for LOW (voltage not present) and greater than 19 volts for HIGH (voltage present).

Operation is correct if the inputs are recognized as follows:

E 95.0 = LOW [24-V-(1)],
E 95.1 = HIGH [24-V-(2)] and
E 95.2 = HIGH [24-V-(3)]

### 3.11.3 Outputs

#### CONNECTORS X11 AND X12

The maximum permissible output current per output is 500 mA. The outputs can only give off current. They are not allowed to accept current. The current output is not limited to 0.5A.

The maximum internal voltage fall is 1.4 volts for nominal current. In LOW status (OFF status) of the output, the output leakage current is less than 0.8 mA (must be taken into account with high-ohmic inputs).

The distribution of the outputs:

Output 1	to 24V (X10/1)
Output 2 - 8	to 24V (X10/2)
Output 9 - 16	to 24V (X10/3)

The outputs can be accessed at the following addresses:

	ADDR	PIN	ADDR	PIN	ADDR	PIN	ADDR	PIN	ADDR	PIN	ADDR	PIN	ADDR	PIN		
X11	88.0	1	88.1	2	88.2	3	88.3	4	88.4	5	88.5	6	88.6	7	88.7	8
X12	89.0	1	89.1	2	89.2	3	89.3	4	89.4	5	89.5	6	89.6	7	89.7	8

The outputs are permitted to work on ohmic or inductive loads. Each output has a free running diode. It is connected to 0V on the anode side, and on the cathode side it is connected with the output.

**Capacitive loads must not be connected to the outputs.**

Light bulbs are only permissible up to a total power of 5 watts per output. If light bulbs up to 12 watts are connected, measures must be adopted to limit the making current.

If the output is overloaded, the overloaded output driver heats up and switches off. The switched off status can be detected by means of the feedback of the outputs. The time that elapses before switching off varies, and is dependent on the ambient temperature, the supply voltage, the intensity of fan operation, the load on the other outputs and the extent of the overload of the output. After an output has switched off because of overloading, the overheated output driver cools down in accordance with the conditions given above. After the output driver has cooled, the output assumes its nominal status. If an output is operating on a short circuit, the current is below 1.7 amperes. The short circuit current is not constant. The output is checked for a short circuit by periodically switching it on for a short time. If the short circuit does not remain, or if the output is reset, the output driver interrupts the cyclical testing of the output. The output returns to its nominal status. All time values and other details are approximate values and only reflect typical conditions and approximations (orders of magnitude).

### **3.11.4 Generating and Applying the 24 Volts**

The 24 volt supply must be implemented with a transformer conforming to **VDE 0551**. Furthermore, the 0V of the 24V load side (secondary side) must be connected to the primary side (mains side) earth potential (PE).

The 24 volt supply is implemented separately from the 24 volt supply for the NC power supply module. The 24 volt supply for the NC power supply module must only be resorted to if it is assured that the power supply module load permits load changing at the outputs without any effect on the NC supply.

The connection of the power supply is implemented with 1.5 cubic mm of Cu wire per terminal. When the three 24 V circuits are combined, it is possible to call on a total of 2 x 1.5 cubic mm of Cu wire for the 24 V circuits.

**However, all three terminals must be assigned 24 volts.**

The wires must be laid out twisted. The wires that conduct the 0 volt potential to the I/O card must not bear any load from other consumers. The 0 volt wires must be connected directly to the 0 volt bar for the load supply. The shortest possible connection must be selected for all voltage supply connections. The wires for the 24 volt circuits and the 0 volt potential must each not be longer than 10 m. It is important to adhere to the minimum voltage to the card. If the supply voltages (24V(X10/2) or 24V(X10/3)) are switched off, the supply voltage of the respective output driver is also switched off. If the voltage of a 24 V circuit that has failed or been switched off is then switched on again, the outputs assume the nominal status that is valid at that point in time. The person who creates an emergency stop circuit or disabling circuit is responsible for testing to what extent the suggestion can be applied to the design of one of the above circuits.

### 3.11.5 Extensions

The I/O module can optionally be extended, as required, with a PIC250 (integrated PLC) and a CAN interface card (digital drive interface). The connection to the CAN bus is implemented with connector X51 (15-pole SUB-D).





### 3.12 Module NC-PLC-I/O

This module allows direct interfacing with PLC I/O modules in a combination rack or with external PLC I/O modules. If used in a combination rack, connection to PLC I/O modules is via the backplane. External PLC I/O modules are connected to the AG/Z-S is by means of the NC-PLC-Bit extension cable.

**Note:**

The I/O modules must be set consecutively starting at address 88.0; see also **rho3 Signal descriptions**.



**Front view NC-PLC-I/O interface module**



**Note:**

Modules must be **switched off** before they are removed from the controller or PLC.

**Write protection PIC 250**

Position 0:

Accessing the PIC program is possible (Edit, Delete).

However, it is only possible to edit one inactive PIC program.

Position 1:

PIC 250 memory is blocked for write protection.

**Caution:**

Write protection must be activated when the PIC program starts (position 1). If this is not done, the PIC program may be lost!

**Supply voltage input (connection X10)**

Supply voltage 24V=; (plug-in terminal, 4 pin). polarized supply voltage input for the digital outputs at X11. Supplied from a 24V load power supply module. Maximum input current: 4A.

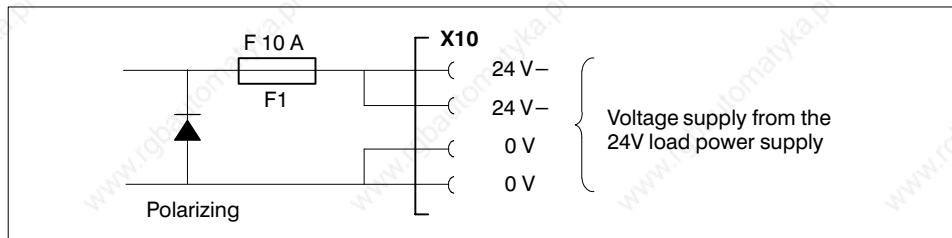

**LED 12V**

The internal 12V supply for the CMOS bus is present.

**LED logic**

The internal logic voltage for the PLC-I/O module is present.

**System connection to the external PLC (connection X11)**

(Connector, subminiature, 50 pin).

Bus connection between the CNC and the PLC module AG/Z or AF/P to the bit coupling between the CNC and PLC.

⚠ **The bus connection cable must be in a de-energized state before it is connected to or removed from the CNC and the PLC.**

**DNC interface (option) (connection X31)**

(Connector, subminiature, 25 pin)

For connection assignments, see section 1.4.5 "DNC interfaces".

**3.12.1 NC-PLC-Bit connection cable to the AG/Z**



**Pin assignment X11**

Color	Qty.	Qty.	Color	Qty.	Qty.	Color	Qty.	Qty.
black	3	3	orange–white	20	20	orange–black	37	37
blue	4	4	brown–white	21	21	brown–black	38	38
brown	5	5	blue–red	22	22	red–green	39	39
beige	6	6	yellow–red	23	23	gray–green	40	40
yellow	7	7	green–red	24	24	violet–green	41	41
green	8	8	white–red	25	25	white–green	42	42
violet	9	9	orange–red	26	26	orange–green	43	43
pink	10	10	brown–red	27	27	brown–green	44	44
orange	11	11	red–black	28	28	red–yellow	45	45
transparent	12	12	blue–black	29	29	blue–yellow	46	46
red–white	13	13	green–yellow	30	30	violet–yellow	47	47
blue–white	14	14	yellow–black	31	31	white–yellow	48	48
yellow–white	15	15	green–black	32	32	brown–yellow	49	49
green–white	16	16	voilet–black	33	33	red–blue	50	50
violet–white	17	17	white–black	36	36			

**Ordering information**

Type	No.
Cable NC-PLC-Bit 0.55m (for AG/Z)	041 535
Cable NC-PLC-Bit 1.8m	048 081

When using the PC-I/O-S interface card, use the following cables and interface modules:

Cable NC-PLC-Bit 0.55m (for AG/Z–S)	064754
Cable NC-PLC-Bit 1.8m	048 755

### 3.13 Module NC-PLC-Bit (Bit Coupler)

Using the module NC-PLC-Bit, an external PLC (PC600, CL300, CL500) can be coupled to the RC on the basis of a bit coupling. To do this, you need the PLC module AG/Z or AG/P on the PLC side.

The PLC can then access the individual RC input/outputs. The corresponding addresses for bit coupling to the RC can be found in **rho3 Signal descriptions**.

To prevent a conflict of addresses with PLC I/O signals, the start address of the rho 3 digital interface can be defined via machine parameter P20, cf.

#### rho3 Description of the machine parameters.

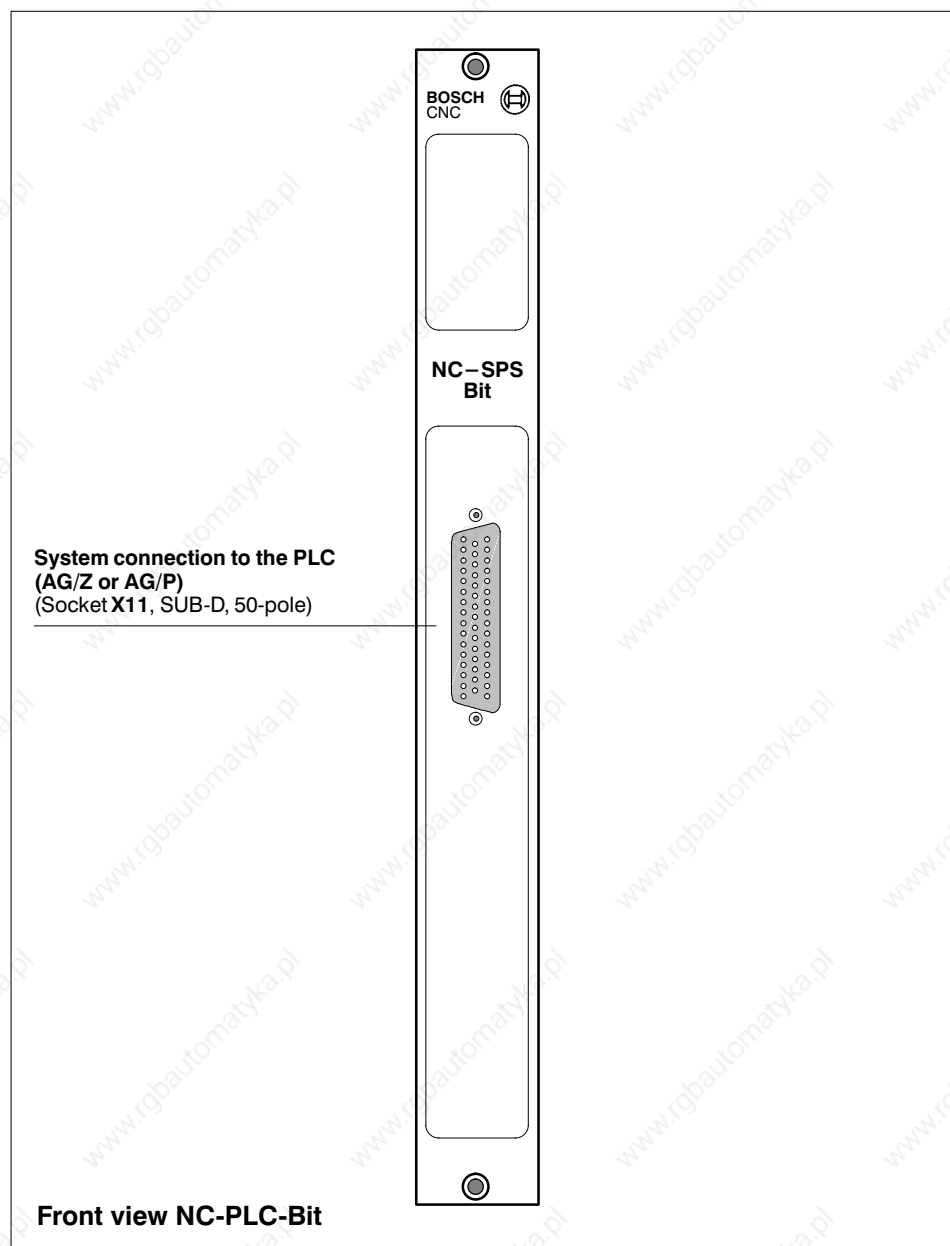

**Caution:**

The module must only be disconnected from the controller and PLC when it is **switched off!**

**System connection to the external PLC (terminal X11)**

(Socket, SUB-D, 50-pole)

Bus connection between the RC and the PLC module AG/Z or AG/P for bit coupling between RC and PLC.

**The bus connection cable must only be connected or disconnected when the RC and PLC are switched off!**

**3.13.1 Connection cable NC-PLC-Bit to AG/Z or AG/P.**



**Ordering information**

Type	No.
Cable NC-PLC-Bit 0.55m (for AG/Z or AG/P)	041 535
Cable NC-PLC-Bit 1.8m (for AG/P)	048 081

**3.13.2 Connection cable NC-PLC-Bit to AG/Z-S or AG/P-S.**



**Pin assignment X11**

Color	Qty.	Qty.	Color	Qty.	Qty.	Color	Qty.	Qty.
black	3	3	orange-white	20	20	orange-black	37	37
blue	4	4	brown-white	21	21	brown-black	38	38
brown	5	5	blue-red	22	22	red-green	39	39
beige	6	6	yellow-red	23	23	grey-green	40	40
yellow	7	7	green-red	24	24	violet-green	41	41
green	8	8	white-red	25	25	white-green	42	42
violet	9	9	orange-red	26	26	orange-green	43	43
pink	10	10	brown-red	27	27	brown-green	44	44
orange	11	11	red-black	28	28	red-yellow	45	45
transparent	12	12	blue-black	29	29	blue-yellow	46	46
red-white	13	13	green-yellow	30	30	violet-yellow	47	47
blue-white	14	14	yellow-black	31	31	white-yellow	48	48
yellow-white	15	15	green-black	32	32	brown-yellow	49	49
green-white	16	16	violet-black	33	33	red-blue	50	50
violet-white	17	17	white-black	36	36			

**Ordering information**

Type	No.
Cable NC-PLC-Bit 1.80 m (for AG/Z-S or AG/P_S)	0750008

### 3.14 Power supply PS 75

The power supply supplies the **internal** voltages for the logic circuits of all plug-in units (CP/MEM4 etc.).



**Caution:**

The module PS 75 must be removed only when the control is **switched off**.

**Output voltage LED**

Output voltage indicator. The LED lights up when the logic supply voltage is output at the PS 75.

**Ready 2 – LED**

The control is ready for operation when the contact is closed and the green LED READY lights up.

The control is not ready for operation if the contact is open.

This is equivalent to an EMERGENCY–STOP operation and must be correspondingly configured in the interface control.

**The Ready 2 circuit monitors the following errors:**

- Voltage fault            Overtemperature > equal to 58 °C supply air
- Servo error             Measuring system error
- Watchdog–Error

**24 V input voltage LED**

The green LED lights up when the 24 V input voltage is present.

**Reset key**

Key to reset all error messages and restart the CNC (HW reset).

**Ready 2 (X20)**

Relay contact (NO contact) opens in the event of errors as described for the Ready 2 LED (switching capacity 50 W/24 V DC,  $I_{max} = 2 A$ ).

**Input voltage 24 V (connection X10)**

Screw terminal, 4–pole.

Incoming supply of 24 V = +30 %/– 15 %, max. 1.2 V<sub>pp</sub> ripple voltage. The input is polarized. Power consumption 125 W.

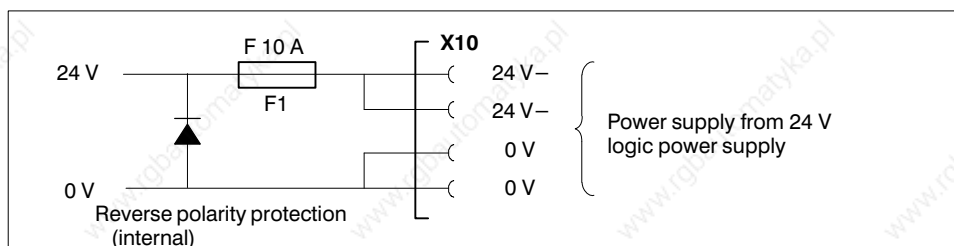

### 3.15 Module PS 200 (power supply)

The power supply provides the voltages for the logic circuits of all plug-in units (CP 2.5, MEM 5 etc.) and the measuring system supply voltages.

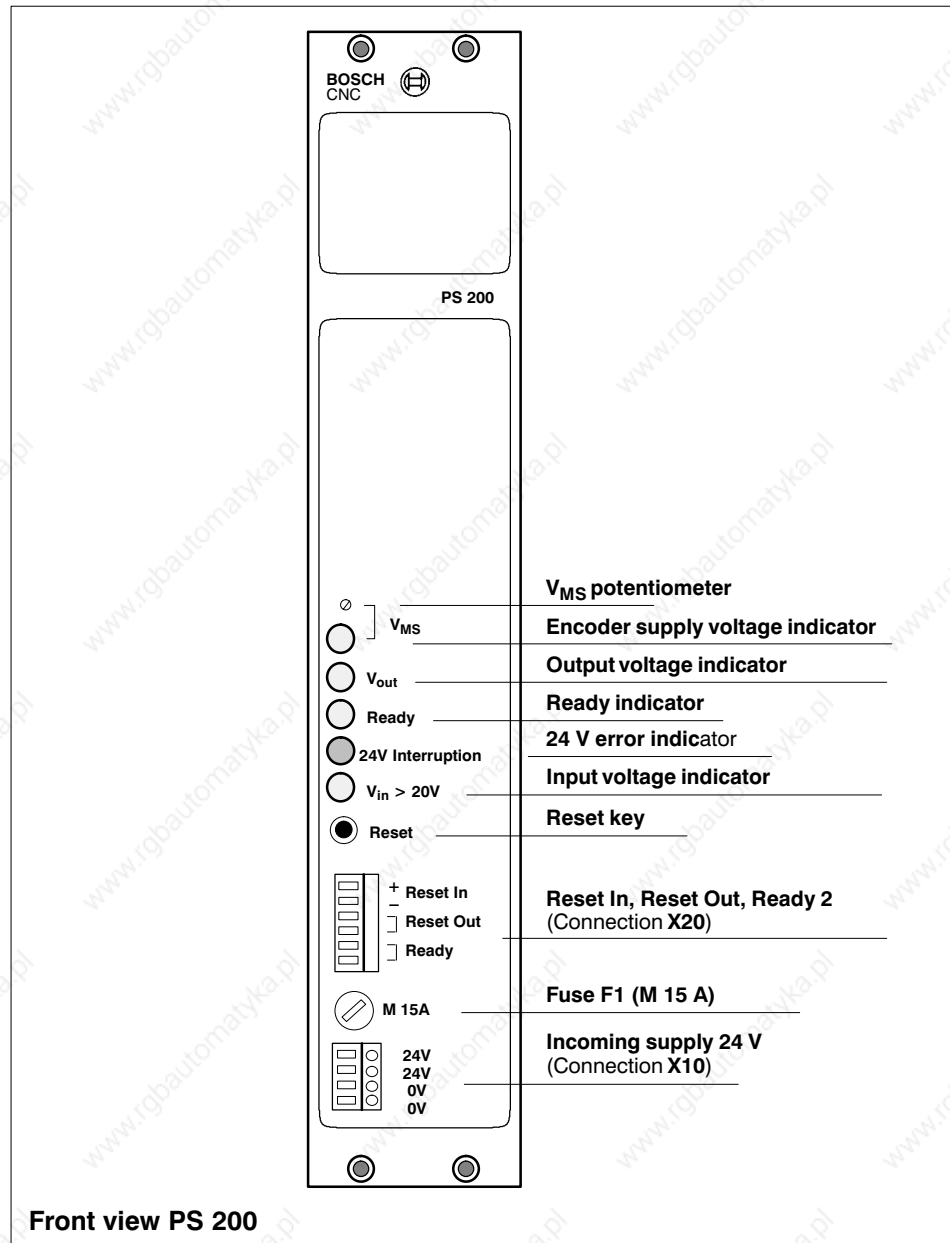

**Caution:**

The module PS 200 must be removed only when the control is switched off.



**V<sub>MS</sub> potentiometer**

This potentiometer is used to adjust the measuring system supply voltage. Adjustment range: 5 V =; +20 %, -6 %

The encoder supply voltage must be adjusted so that the encoder supply voltage is +5 V for all connected encoders and the permitted cable length (+/- 5 % measured directly at the individual encoders).

**Encoder supply voltage indicator**

The LED lights up when the encoder supply voltage is output at the PS 200.

**Output voltage indicator**

The LED lights up when the supply voltage for the plug-in units in the card rack is output at the PS 200.

**Ready indicator**

The LED lights up if **none** of the following errors are present:

- Internal voltage error
- Overtemperature (> 58 °C internal)
- Measuring system error- Servo loop error
- Processor error

**24 V interruption indicator**

The LED lights up if the external supply voltage at X10 has been interrupted briefly (10 ms < t < 10 s).

The 24 V error is cleared by pressing the Reset key (CNC restart) or by a voltage interruption of at least 30 seconds).

**Input voltage indicator**

The LED lights up when the external supply voltage (24 V =) is present at X10.

**Reset key**

Reset of all errors and CNC restart.

**Incoming supply 24 V (connection X10)**

Incoming supply 24 V =; (screw terminal, 4-pole).

Polarized supply voltage connection. Is supplied from a 24 V logic power supply (see Section 1.9.2).

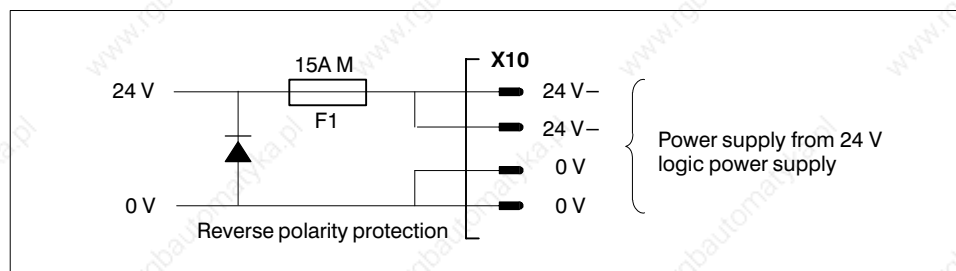

**Reset in, Reset Out, Ready 2 (connection X20)**

(Plug-in terminal, 6-pole)

Reset In: Relay input (same function as Reset key)

Reset Out: Relay contact (NO contact) opens in the event of an internal voltage fault and overtemperature ( $> 58^{\circ}\text{C}$  internal) and if the input voltage is missing at X10.

Ready 2: Relay contact (NO contact) opens in the event of the same errors as described under "Ready indicator".

**The control is not ready for operation when the contact is open. Consequently, Ready 2 must be correspondingly configured in the interface control (with EMERGENCY-STOP).**

**For safety reasons, the load voltage must be switched off first and then the logic voltage when the system is switched off**



## 4 Programmable manipulator PHG 3

The PHG 3 (from the German "*Programmier-Handbediengerät*", or programmable manipulator) is used for programming and operating the rho 3 controller.

### 4.1 Construction

The PHG 3 programmable manipulator is designed for mobile use and consists of a housing which contains the electrical components.

The housing is made of black high-impact plastic.

The key pad and display are located on the front, and the confirmation key and EMERGENCY STOP button are on the side of the PHG.

The PHG is connected to the controller by means of an adaptor cable.

**Protection rating : IP54**



Fig. 1

#### 4.2 Environmental conditions

Operating temperature range: + 5 to + 45° C

Storage temperature range: -20 to + 65° C

#### 4.3 Keypad

The PHG 3 has a total of 36 keys.

The CONFIRMATION KEY is located on the side of the PHG 3.

Key assignment is by means of a replaceable key labelling mask which is currently available in German and English.

#### 4.4 Display

The PHG 3's display is a 4 line, 20 character LCD.

Character height: approx. 5 mm.

#### 4.5 Emergency stop

The EMERGENCY STOP button is an emergency palm button with locked operating element and safety contact.

Color: red operating element with yellow contrast surface.

Load: 24V/2A – The voltage in the EMERGENCY STOP circuit must not deviate beyond 24V +20% –15%.

The EMERGENCY STOP contact on the connector is for wiring into the EMERGENCY STOP circuit.

#### 4.6 Confirmation key

The CONFIRMATION KEY is located on the side of the PHG 3 and is a two-channel design:

one channel is evaluated directly in the RC;  
the second channel is available for wiring on the connector as a potential-free contact and must be linked to the interface controller.

The confirmation key is arranged so that it can be used by right-handers as well as left-handers.

It must be pressed if a machine movement can be initiated in the MANUAL operating mode (see also the rho 3 PHG operating instructions).

The confirmation key must be linked to the safety circuit of the interface controller by means of an auxiliary relay.

**4.7 Cable and Connector**

Type:	A special cable is used: LIYCY-CY 4 x 0.3 mm <sup>2</sup> + 3 x 2 x 0.19 mm <sup>2</sup>
Cable length:	8 m, standard
Cable assignment:	See Fig. 1.1
Connector:	25-pin subminiature connector

**4.8 Interface**

A special current-loop interface is used for reliably transmitting data of data. The connection between the PHG 3 and the controller is permanently monitored. The confirmation key is a two-channel design and is used for transmitting information to the controller. In addition, it serves as a contact for interconnecting with the interface controller.

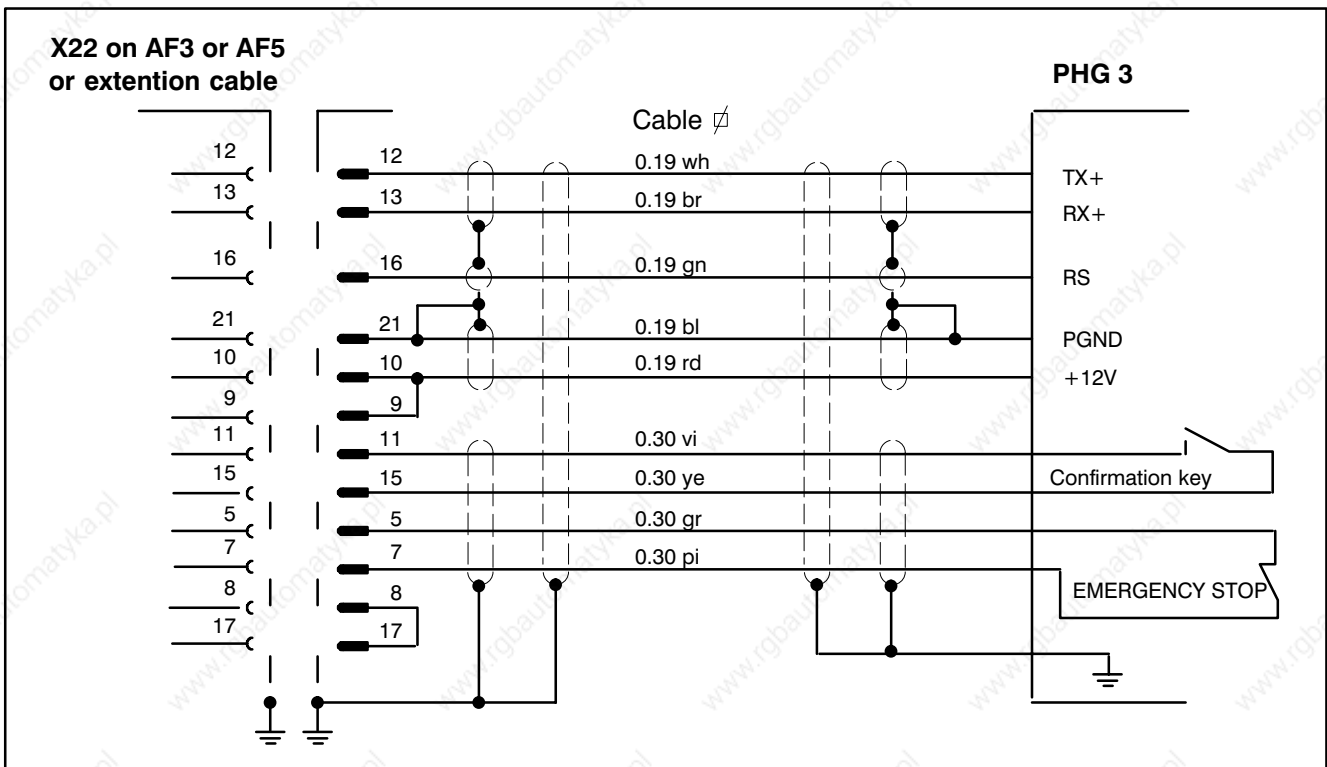

**Fig. 1.1**

### 4.9 Adaptor cable

The PHG cannot be directly connected to the interface of the rho 3 controller. Instead, it is connected to the controller by means of an adaptor cable (see Fig. 1.2. Für die zwei unterschiedlichen Hardwarekonzepte rho 3.1 und rho 3.2 stehen entsprechende Kabel zur Verfügung.



Fig. 1.2

### 4.10 Extension cable for the PHG

The connection between the interface field (AF3 or AF5) and the PHG can be extended with the proper extension cable by a max. of 45 m . See Fig. 1.4.

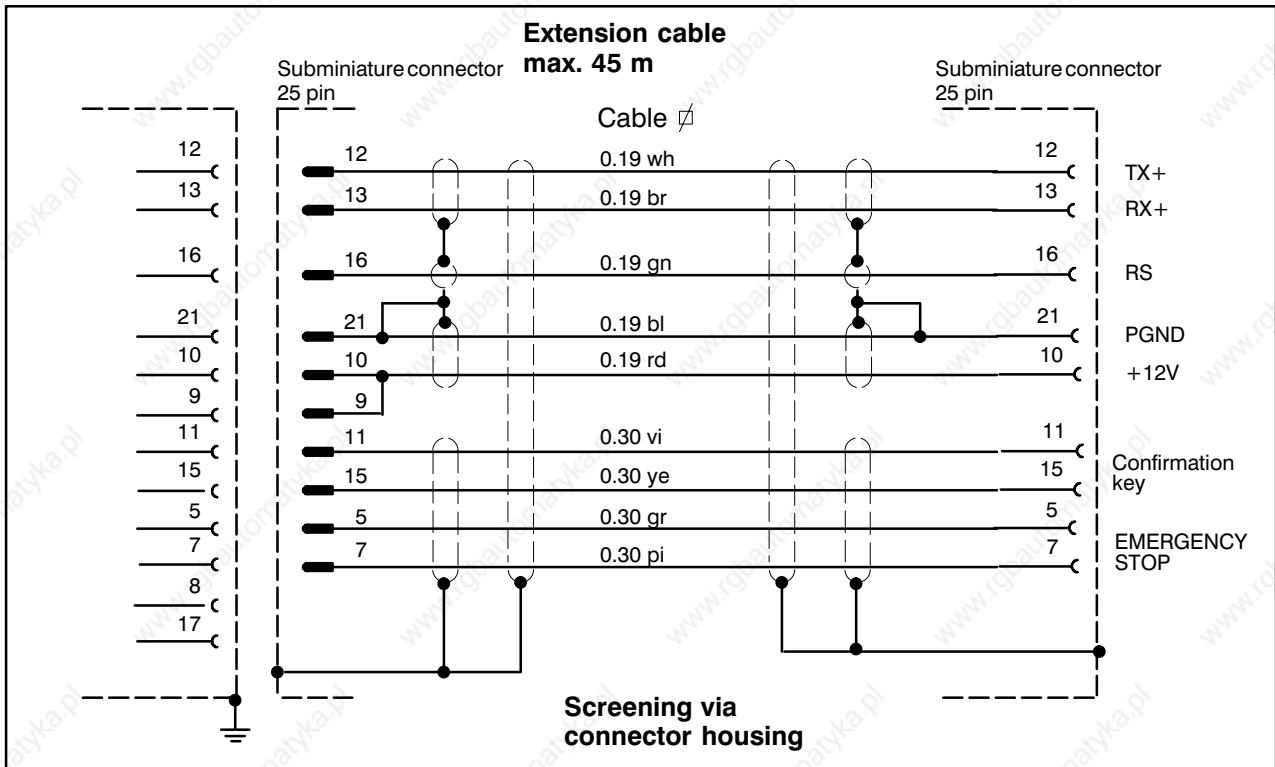

Fig. 1.4

# Bosch-Automationstechnik

Robert Bosch GmbH  
Geschäftsbereich  
Automationstechnik  
Industriehydraulik  
Postfach 30 02 40  
D-70442 Stuttgart  
Telefax (07 11) 8 11-18 57

Robert Bosch GmbH  
Geschäftsbereich  
Automationstechnik  
Fahrzeughydraulik  
Postfach 30 02 40  
D-70442 Stuttgart  
Telefax (07 11) 8 11-17 98

Robert Bosch GmbH  
Geschäftsbereich  
Automationstechnik  
Pneumatik  
Postfach 30 02 40  
D-70442 Stuttgart  
Telefax (07 11) 8 11-89 17

Robert Bosch GmbH  
Geschäftsbereich  
Automationstechnik  
Montagetchnik  
Postfach 30 02 07  
D-70442 Stuttgart  
Telefax (07 11) 8 11-77 12

Robert Bosch GmbH  
Geschäftsbereich  
Automationstechnik  
Antriebs- und Steuerungstechnik  
Postfach 11 62  
D-64701 Erbach  
Telefax (0 60 62) 78-4 28

Robert Bosch GmbH  
Geschäftsbereich  
Automationstechnik  
Schraub- und Einpreßsysteme  
Postfach 11 61  
D-71534 Murrhardt  
Telefax (0 71 92) 22-1 81

Robert Bosch GmbH  
Geschäftsbereich  
Automationstechnik  
Entgrattechnik  
Postfach 30 02 07  
D-70442 Stuttgart  
Telefax (07 11) 8 11-34 75

Technische Änderungen vorbehalten

Ihr Ansprechpartner

# BOSCH



Robert Bosch GmbH  
Geschäftsbereich  
Automationstechnik  
Antriebs- und Steuerungstechnik  
Postfach 11 62  
D-64701 Erbach  
Telefax (0 60 62) 78-4 28