

MRP2 - Directional power relay

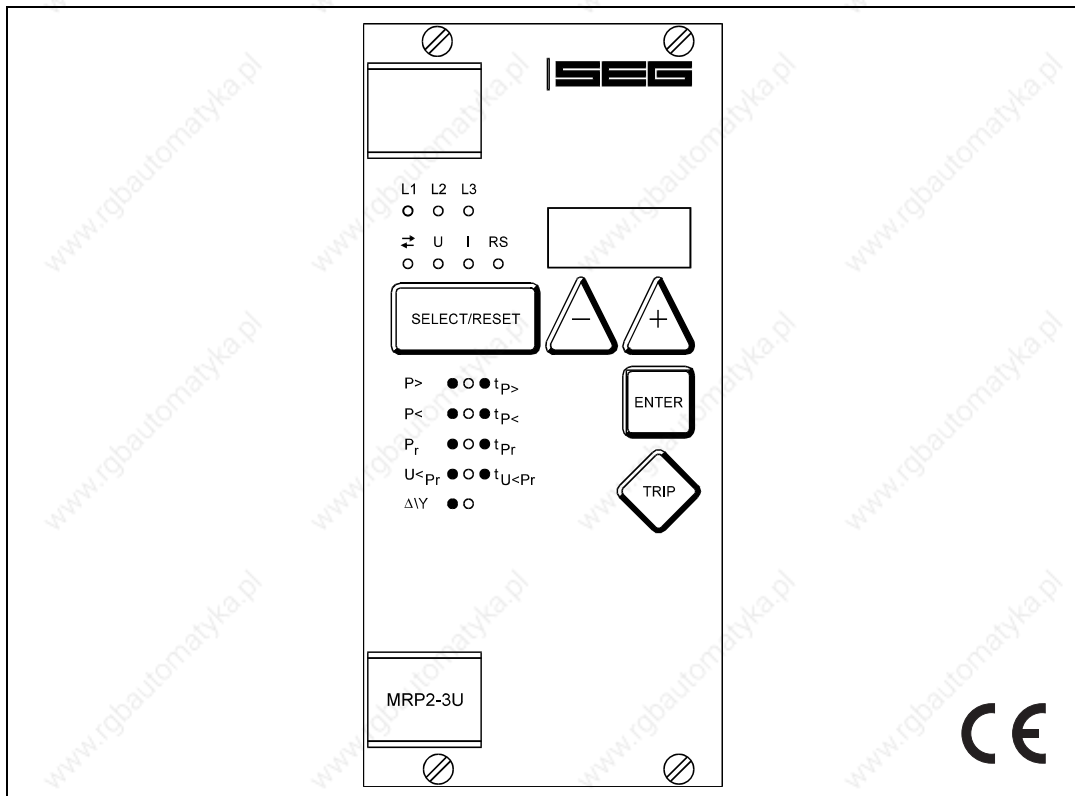

Contents

1 Introduction and application

2 Features and characteristics

3 Design

- 3.1 Connections
 - 3.1.1 Analog input circuits
 - 3.1.2 Output relays
 - 3.1.3 Blocking input
 - 3.1.4 External reset input
- 3.2 LEDs

4 Working principle

- 4.1 Analog circuits
- 4.2 Digital circuits
- 4.3 Measuring principle
- 4.4 Demand imposed on the main current transformers

5 Operations and settings

- 5.1 Display
- 5.2 Setting procedure
 - 5.2.1 Pickup value for power increase ($P>$), power decrease ($P<$) and reverse power (Pr)
 - 5.2.2 Pickup value for undervoltage $U_{<pr}$ of the voltage dependent reverse power element
 - 5.2.3 Tripping times for power increase ($P>$), power decrease ($P<$) and reverse power (Pr)
 - 5.2.4 Y/Δ - Change-over of the input transformers
 - 5.2.5 Circuit breaker failure protection t_{CBFP}
 - 5.2.6 Selection of the rated voltage (100V/110V)
 - 5.2.7 Display of the activation storage (FLSH/NOFL)
 - 5.2.8 Adjustment of the slave address
 - 5.2.9 Setting of Baud rate (applies for Modbus Protocol only)
 - 5.2.10 Setting of parity (applies for Modbus protocols only)
 - 5.2.11 Blocking the protection functions and assignment of the output relays
- 5.3 Indication of measuring values and fault data
 - 5.3.1 Indication of measuring values
 - 5.3.2 Indication of fault data
 - 5.3.3 Fault Recorder
- 5.4 Reset
- 5.5 Hints for the setting procedure
 - 5.5.1 Setting of the power measuring circuits switching point

6 Relay Testing and commissioning

- 6.1 Power-On
- 6.2 Testing the output relays
- 6.3 Checking the set values
- 6.4 Secondary injection test
 - 6.4.1 Test equipment
 - 6.4.2 Example of test circuit for *MRP2* relay
 - 6.4.3 Checking the input circuits and measured values
 - 6.4.4 Checking the operating and resetting values of the relay
 - 6.4.5 Checking the relay operating time
 - 6.4.6 Test of the CB failure protection
 - 6.4.7 Checking the external blocking and reset functions
- 6.5 Primary injection test
- 6.6 Maintenance

7 Technical data

- 7.1 Measuring input circuits
- 7.2 Common data
- 7.3 Setting ranges and steps
 - 7.3.1 Setting ranges and steps *MRP2-1* and *MRP2-3*
 - 7.3.2 Setting ranges and steps *MRP2-R1* and *MRP2-R3*
 - 7.3.3 Interface parameters
- 7.4 Output contact ratings

8 Order form

Important:

For additional common data of all **MR**-relays please refer to manual "**MR** - Digital Multifunctional Relays".

This technical manual is valid for software version

D13-4.12 (MRP2-1) or
D14-4.12 (MRP2-3) onwards!

1 Introduction and application

The power relay *MRP2* is used in 3-phase systems for active power measurement.

In the single-phase relay type *MRP2-1*, the load of the three phases is assumed to be symmetrical so that a single phase power measurement can be realized. For application fields (i.e. turbine movers) where two reverse power switching points with higher precision are required, the relay type *MRP2-R* is available.

Among others, the *MRP2*-relays serve:

- for supervision of load flow between two systems. (*MRP2*)

If the generated power of one system fails, unimportant consumers have to be disconnected by the power relay. Thereby the mains is stabilised and the supply of important consumers maintained. If gen.-sets are operating in parallel, these consumers can be disconnected if the load remains below the set minimal value or - in peak load operating mode - they can be connected if a limit value for the mains power is exceeded.

- as reverse power relay to protect turbines and Diesel gen.-sets from reverse power if this prime mover fails. (*MRP2* and *MRP2-R*)

For generators operating in parallel with a mains or another generator, it is imperative to supervise the power direction. If for example the prime mover fails the alternator operates as a motor and drives the prime mover (diesel or turbine). The *MRP2* "recognizes" the reverse of the power direction and - in case of this error - switches off the alternator. This way, power losses and damages of the prime mover are avoided.

- as voltage dependent reverse power relay for mains decoupling

The criterium for tripping the voltage-dependent reverse power element is the reverse power with simultaneous voltage decrease as a result of an external mains fault. Decoupling prevents external mains faults from affecting the own mains section. Internal faults are selectively detected by other protection devices.

2 Features and characteristics

Unit *MRP2* still has another feature besides those described in the general *MR*-description, namely:

- Measuring of the actual power by means of multiplication and integration of the instantaneous values of current and voltage.
- Correct measuring even at unequally loaded phases (*MRP2-3*).
- Switchable measuring for delta or star connection of v.t.'s.
- Indication of current, voltage and power
- Serial interface
- Three adjustable power switching-points.
- voltage dependent reverse power element
- Plug-in type design with automatic short-circuiters for current transformer circuits.
- Circuit Breaker failure protection
- Storing of trip values and breaking times (t_{CBFP}) of eight fault events
- Ability of serial data transmission via RS485 interface optional with SEG RS485 Pro Open Data Protocol or Modbus Protocol

3 Design

3.1 Connections

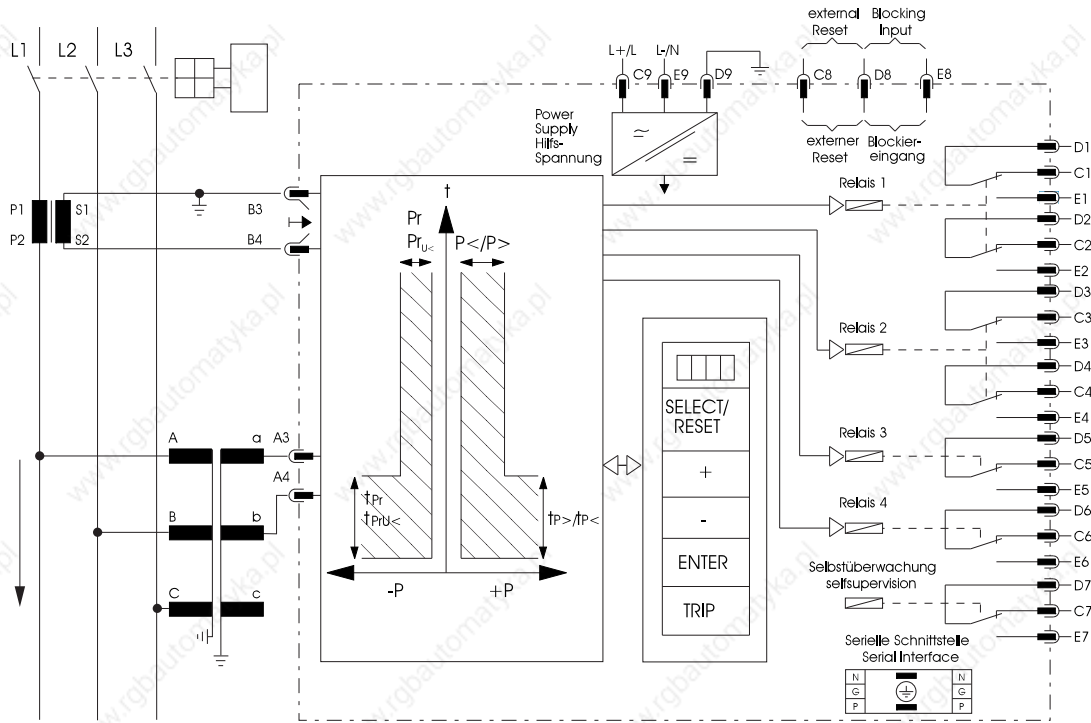

Fig. 3.1: Connection diagram MRP2-1 and MRP2-R1 (Star/Delta adjustment has to be set to DELTA)

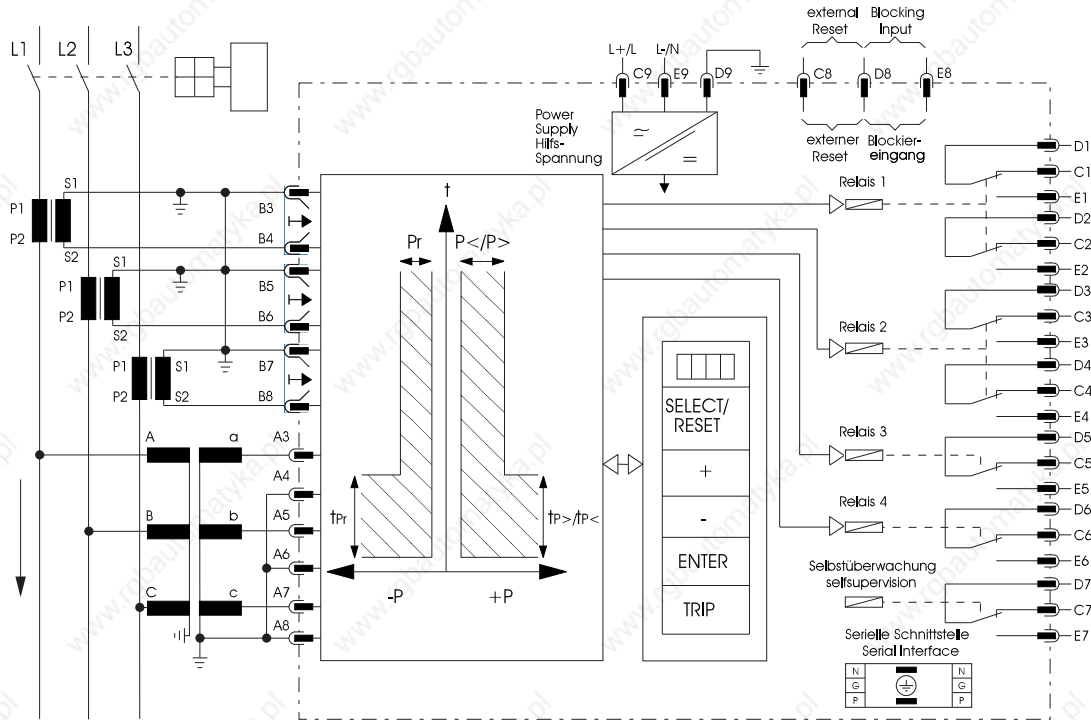

Fig. 3.2: Connection diagram MRP2-3 and MRP2-R3 (Star/Delta adjustment has to be set to Y)

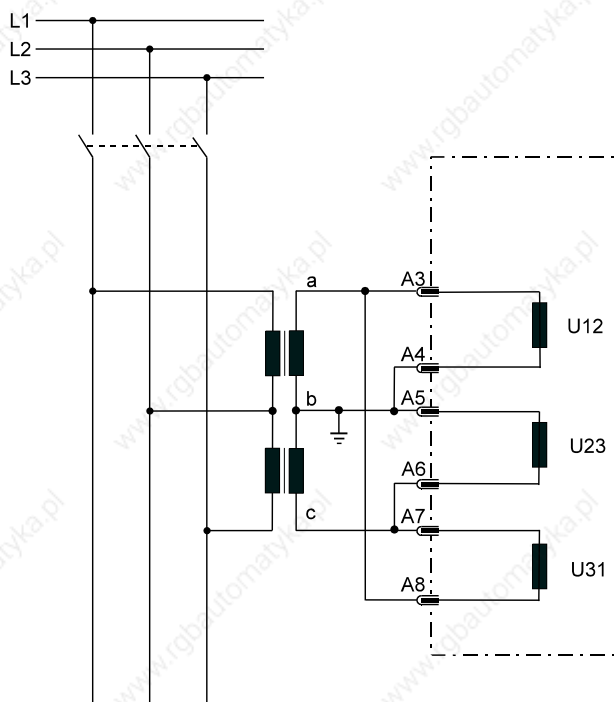

Fig 3.3: Voltage transformer in V-connection

3.1.1 Analog input circuits

The analog input signals of the conductor currents I_{L1} (B3-B4), I_{L2} (B5-B6), I_{L3} (B7-B8) and the phase voltages U1 (A3), U2 (A5), U3 (A7) with A8 as starpoint are each transmitted to the protection device *MRP2-3* by means of separate input transformers (star connection).

At the single-phase version of unit *MRP2-1* the input signals are also transmitted via separate input transformers: I_{L1} (B3-B4); U1 (A3-A4).

The constantly measured current values are galvanically decoupled, filtered by a low pass-filter and finally fed to the analog/digital converter.

3.1.2 Output relays

The *MRP2* is equipped with 5 output relays. Apart from the relay for self-supervision, all protective functions can be optionally assigned:

- Relay 1: C1, D1, E1 and C2, D2, E2
- Relay 2: C3, D3, E3 and C4, D4, E4
- Relay 3: C5, D5, E5
- Relay 4: C6, D6, E6
- Self-supervision C7, D7, E7

All trip and alarm relays are working current relays, the relay for self-supervision is an idle current relay.

3.1.3 Blocking input

The function for blocking can be parameterized arbitrary. When an auxiliary voltage is connected to D8/E8 those relay functions will be blocked which were parameterized before (refer to chapter 5.2.6).

3.1.4 External reset input

Please refer to chapter 5.4

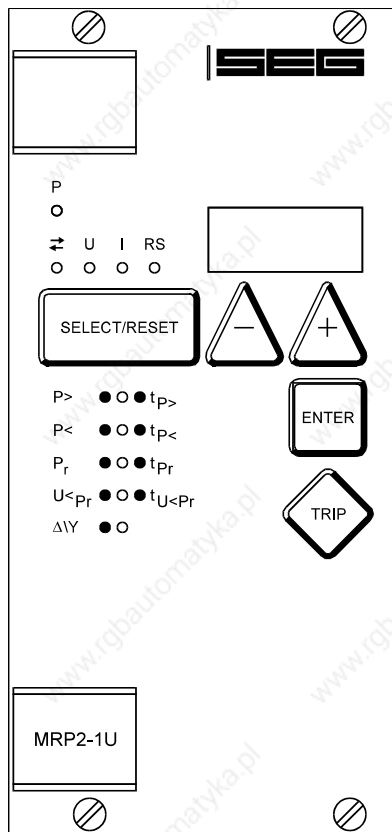

Fig.3.4: Front plate MRP2-1 and MRP2-R1

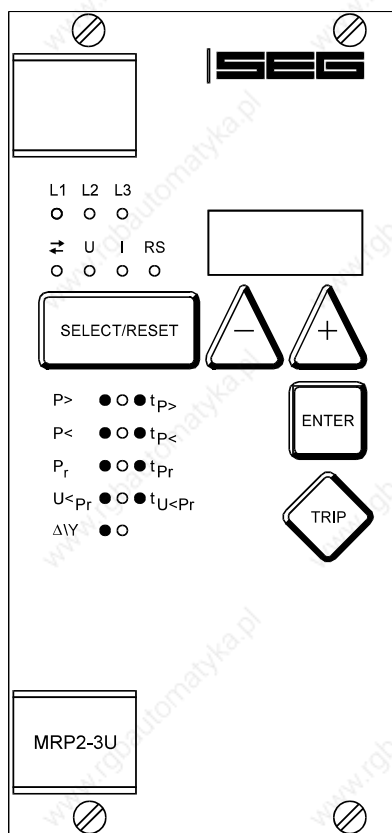

Fig. 3.5: Front plate MRP2-3 and MRP2-R3

3.2 LEDs

Measuring values will be indicated on display together with the LEDs P, L1, L2, L3, U and I (refer to chapter 5.3).

The **MRP2** provides one LED to indicate the power direction (green and red arrow). Green indicates generator power, red indicates reverse power.

For setting and indication of protection trippings the LEDs beneath the push buttons are used.

The five LEDs below push-button <SELECT/RESET> are bi-coloured: green relates to P_>, P_<, P_r, U_{<Pr}, Δ/Y, red relates to t_{p>}, t_{p<} and t_{pr} and t_{U<Pr}.

The LED marked with letters RS lights up during setting of the slave address of the device for serial data communication.

4 Working principle

4.1 Analog circuits

The incoming currents from the main current transformers on the protected object are converted to voltage signals in proportion to the currents via the input transformers and burden. The noise signals caused by inductive and capacitive coupling are suppressed by an analog R-C filter circuit.

The analog voltage signals are fed to the A/D-converter of the microprocessor and transformed to digital signals through Sample- and Hold- circuits. The measuring value detection takes with a sampling frequency of 900 Hz (1080 Hz), namely, a sampling rate of 1.11 ms (0.93 ms) for every measuring quantity at 50 Hz (60 Hz).

4.2 Digital circuits

The essential part of the **MRP2** relay is a powerful microcontroller. All of the operations, from the analog digital conversion to the relay trip decision, are carried out by the microcontroller digitally.

By means of a special protective routine stored in the EPROM, the microprocessor processes currents and voltages at the analog inputs and then - based on the measured values - calculates the existing power.

The measured power is permanently compared with the threshold value stored in the parameter memory (EEPROM - Electrically Erasable Programmable Read-Only Memory). If a measured power exceeds the pickup value, an alarm is given and after the set trip delay has elapsed, the corresponding trip relay is activated.

The relay setting values for all parameters are stored in a parameter memory (EEPROM), so that the actual relay settings cannot be lost, even if the power supply is interrupted.

The microprocessor is supervised through a built-in "watch dog" timer. In case of a failure the watch dog timer resets the microprocessor and gives an alarm signal, via the output relay "self supervision".

4.3 Measuring principle

Through multiplication of the actual current and voltage values $p(t) = u(t) \cdot i(t)$, the microprocessor calculates the phase power. 18 instantaneous values are measured and recorded per cycle. Afterwards the power value during one cycle is determined.

$$P = \frac{1}{T} \int P(t) \cdot dt$$

Consequently, the total three phase current is calculated from: $P_{total} = P1 + P2 + P3$

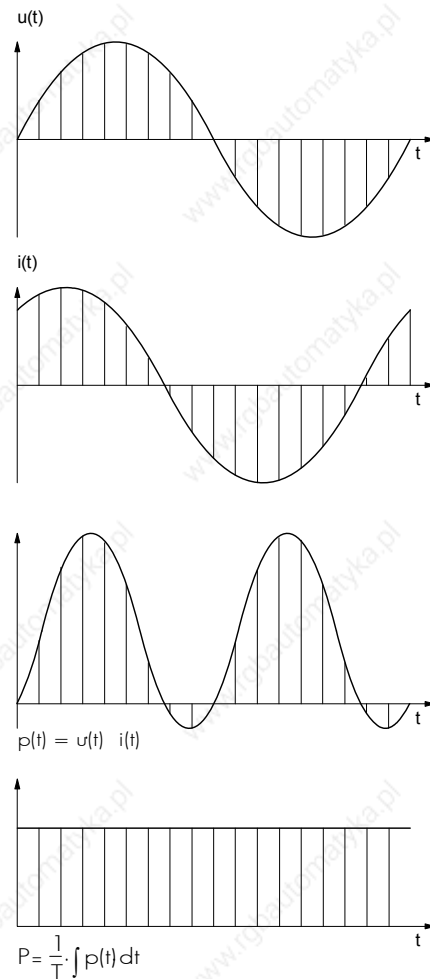

Fig. 4.1: Power measurement

4.4 Demand imposed on the main current transformers

The current transformers must be designed in such a manner that they are precisely dimensioned for pure reverse power in the lower range especially with the **MRP2-R**. We therefore recommend the use of measuring transformers which are at least type 1M5. The low energy consumption of the **MRP2-R** of <0.2 VA has a positive effect on the design of the current transformers.

5 Operations and settings

5.1 Display

Function	Display shows	Pressed pushbutton	Corresponding LED
Normal operation	SEG		
Measured operating values phase voltages, phase currents, power and power direction	Actual measured voltage U_{L1} , U_{L2} , U_{L3} , U_{L12} , U_{L23} , U_{L31} current I_{L1} , I_{L2} , I_{L3} power P_{tot} , P_{L1} , P_{L2} , P_{L3}	<SELECT/RESET> one time for each value	L1/U, L2/U, L3/U, L1/I, L2/I, L3/I →← P/L1/L2/L3
Setting values delta/star-connection adjustment	DELTA or Y	<SELECT/RESET><+><->	Δ/Y
power increase	setting value in P_N	<SELECT/RESET> one time for each value	P>
trip delay for power increase	setting value in seconds	<SELECT/RESET> one time for each value	$t_{P>}$
power decrease/reverse power	setting value in P_N	<SELECT/RESET> one time for each value	P<
trip delay for power decrease	setting value in seconds	<SELECT/RESET> one time for each value	$t_{P<}$
reverse power	setting value in P_N	<SELECT/RESET> one time for each value	P_r
trip delay for reverse power	setting value in seconds	<SELECT/RESET> one time for each value	t_{P_r}
undervoltage $U_{<Pr}$	setting value in volts	<SELECT/RESET> one time for each value	$U_{<Pr}$
trip delay $t_{U<Pr}$	setting value in seconds	<SELECT/RESET> one time for each value	$t_{U<Pr}$
Function blockade	EXIT	<+> until max. setting value	LED of blocked parame- ter
Circuit breaker failure protection	CBFP	<SELECT/RESET><+><->	L1, L2, L3, →← * P>, P<, P_r , $U_{<Pr}$
Indication of memorized pickup	FLSH/NOFL	<SELECT/RESET><+><->	
Selection of rated voltage	100 V/110 V	<SELECT/RESET><+><->	U
Slave address of serial interface	1-32	<SELECT/RESET><+><->	RS
Recorded fault data of power	Measured values in the instant of tripping	<SELECT/RESET> one time for each value	L1, L2, L3, P>, P<, P_r^* →←
Recorded fault data of voltage U_1 , U_2 , U_3	Measured values in volts	<SELECT/RESET> one time for each value	L1, L2, L3 and U*
Recorded fault data of current I_1 , I_2 , I_3	Measured values related to I_n	<SELECT/RESET> one time for each value	L1, L2, L3 and I*
Save parameter?	SAV?	<ENTER>	
Save parameter!	SAV!	<ENTER> for about 3 s	
Software version	First part (e.g. D16-) Second part (e.g. 5.01)	<TRIP> one time for each part	
Manual trip	TRI?	<TRIP> three times	
Inquire password	PSW?	<SELECT/RESET> <+><-><ENTER>	
Relay tripped	TRIP	<TRIP> or after fault tripping	L1, L2, L3, →← * P>, P<, P_r
Secret password input	XXXX	<SELECT/RESET> <+><-><ENTER>	
System reset	SEG	<SELECT/RESET> for about 3 s	

Table 5.1: possible indication messages on the display

* The units **MRP2-1** and **MRP2-R1** with single-phase power measurement have only the LED P available instead of LED L1, L2 and L3

5.2 Setting procedure

After push button <SELECT/RESET> has been pressed, always the next measuring value is indicated. Firstly the operating measuring values are indicated and then the setting parameters. By pressing the <ENTER> push button the setting values can directly be called up and changed. For parameter setting a password has to be entered. (please refer to chapter 4.4 of description "MR-Digital Multifunctional Relays")

5.2.1 Pickup value for power increase (P>), power decrease (P<) and reverse power (Pr)

After setting of the pickup value to supervise power increase, (P>), power decrease (P<) and reverse power (Pr), the display indicates a value that is related to the three phase nominal power P_N of the unit.

This means:

Pickup value = indicated value x nominal power ($P_N = \sqrt{3} \cdot U_N \cdot I_N$ with U_N = phase to phase voltage).
Push-buttons <+> or <-> can be pressed to change, <ENTER> to store the indicated value.

It is also possible to use the power decrease relay (P<) as a second reverse power relay. If applied for reverse power protection, the parameters for P< have to be adjusted to „negative values“, the value which is used for Pr must be set „positive“.

In the MRP2-R (reverse power relay with increased precision) unit version, the value for a power increase in forward direction P> can only be set to $0,5 \times P_N$ and must therefore - as a rule - be blocked by means of setting „EXIT“.

The functions P> and Pr are blocked each by incrementing via push-button <+> until „Exit“ appears on the display and storage with push-button <ENTER>. P< is deactivated by incrementing the set value via push-button <-> until „EXIT“ appears on the display. This entry as well has to be stored via push-button <ENTER>.

If trip time is set to exit but not so the threshold belonging to it, tripping is blocked. In case of failure, the belonging alarm relay picks up nevertheless.

Tripping takes place if the sum total of individual loads exceeds or drops below the set value.

5.2.2 Pickup value for undervoltage $U_{<Pr}$ of the voltage dependent reverse power element

When the threshold value of the secondary voltage excitation is being adjusted, the display shows a response value in volt.

The voltage-dependent reverse power element is excited when the device measures a reverse power greater than P_r (set value see 5.2.1) and a secondary voltage smaller than $U_{<Pr}$ in at least one phase. The displayed set values can be changed with the keys <+> and <-> and stored with <ENTER>.

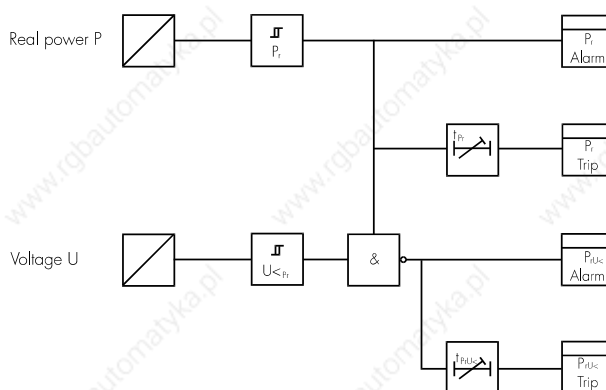

Fig. 5.1: Reverse power element P_r and voltage dependent reverse power element $P_{rU_{<Pr}}$

5.2.3 Tripping times for power increase (P>), power decrease (P<) and reverse power (Pr)

After setting of the tripping times a value indicated in seconds is shown on the display. The required time delay can be entered by means of push-buttons <+> and <-> and is stored via <ENTER>.

5.2.4 Y/ Δ - Change-over of the input transformers

The voltage sensing circuits of the *MRP2* may be connected in either star or delta configuration. The relay rated voltage, U_N , refer to the line-line voltage in the star connection. When the relay is connected in the delta connection the maximum line-to-line voltage must be reduced to $1/\sqrt{3} \times U_N$. During parameter setting the connection configuration either in star or delta has to be specified.

For the single-phase type (*MRP2-1*) phase-to-phase voltage U_{12} or phase-to-neutral voltage U_{1E} can be connected to terminals A3/A4. Pay attention to the correct setting of the star or delta adjustment.

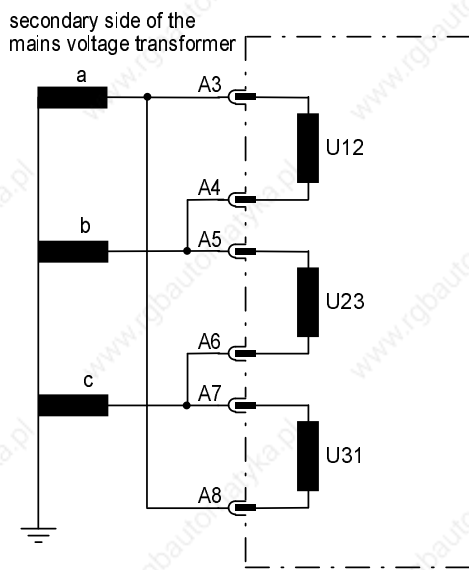

Fig. 5.2: Input transformers in delta-connection (*MRP2-3*)

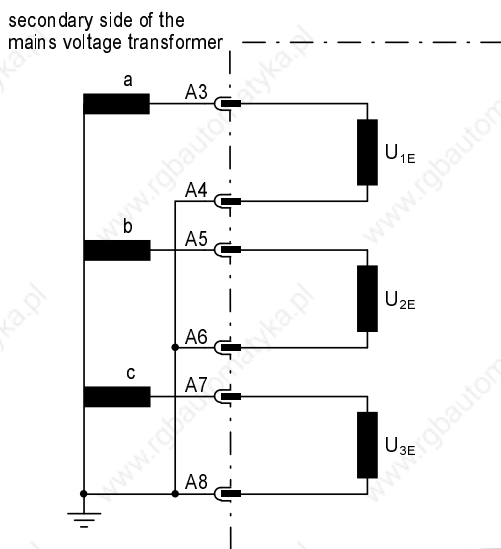

Fig. 5.3: Input transformers in star-connection (*MRP2-3*)

5.2.5 Circuit breaker failure protection t_{CBFP}

The CB failure protection is based on supervision of phase currents during tripping events. Only after tripping this protective function becomes active. The test criterion is whether all phase currents are dropped to $<1\% \times I_N$ within t_{CBFP} (Circuit Breaker Failure Protection - adjustable between 0.1 - 1.6s). If not all of the phase currents have dropped to $<1\% \times I_N$ within this time, CB failure is detected and the related relay activated. The CB failure protection is deactivated again as soon as the phase currents have dropped to $<1\% \times I_N$ within t_{CBFP} .

5.2.6 Selection of the rated voltage (100V/110V)

Relay types with a rated voltage of 100 V can optionally be adjusted to 110 V rated voltage. This simplifies calculation of the trip value of 110 V systems. This parameter can be changed by push buttons $\langle + \rangle$ and $\langle - \rangle$ and saved by pressing $\langle \text{ENTER} \rangle$.

5.2.7 Display of the activation storage (FLSH/NOFL)

If after an activation the existing power drops again below the pickup value, e.g. $P >$, without a trip has been initiated, LED $P >$ signals that an activation has occurred by flashing fast. The LED keeps flashing until it is reset again (push button $\langle \text{RESET} \rangle$). Flashing can be suppressed when the parameter is set to NOFL.

5.2.8 Adjustment of the slave address

Pressing push buttons $\langle + \rangle$ and $\langle - \rangle$ the slave address can be set in the range of 1 - 32. LED RS lights up during setting procedure.

5.2.9 Setting of Baud rate (applies for Modbus Protocol only)

Different transmission rates (Baud rate) can be set for data transmission via Modbus protocol.

The rate can be changed by push buttons <+> and <-> and saved by pressing <ENTER>.

5.2.10 Setting of parity (applies for Modbus protocol only)

The following three parity settings are possible :

- "EVN" = even
- "ODD" = odd
- "NO" = no parity check

The setting can be changed by push buttons <+> and <-> and saved by pressing <ENTER>.

5.2.11 Blocking the protection functions and assignment of the output relays

The blocking function of the *MRP2* can be set according to requirement. By applying the voltage (in the range from aux. voltage) to D8/E8, the functions chosen by the user are blocked. Setting of the parameter should be done as follows:

Setting of blocking input:

- Following the simultaneous activation of the <ENTER> and <TRIP> keys the display shows the text „BL=1“ (the blocking function is active if auxiliary voltage is fed) or „BL=0“ (the blocking function is active if auxiliary voltage is missing).
- By pressing push buttons <+> <-> the value displayed can be changed.
- The changed value is stored by pressing <ENTER> and entering the password.

Function		Display
BLOC	Blockage activ	BL= 1

Table 5.2: Default settings blocking parameters

Blocking the protection functions:

- When pressing push buttons <ENTER> and <TRIP> at the same time, message "BLOC" is displayed (i.e. the respective function is blocked) or "NO_B" (i.e. the respective function is not blocked). The LED allocated to the first protection function P> lights red.
- By pressing push buttons <+> <-> the value displayed can be changed.
- The changed value is stored by pressing <ENTER> and entering the password.
- By pressing the <SELECT/RESET> push button, any further protection function which can be blocked is displayed.
- Thereafter the blocking menu is left by pressing <SELECT/RESET> again.

Function		Display	LED/Colour
P>	power increase	BLOC	P> yellow
P<	power decrease	BLOC	P< yellow
Pr	reverse power	BLOC	Pr yellow
U<Pr	undervoltage	BLOC	U<Pr red
CBFP	C.B. failure protection	NO_B	

Table 5.3: Default settings of blocking functions

Assignment of the output relays:

Unit *MRP2* has five output relays. The fifth output relay is provided as permanent alarm relay for self supervision is normally on. Output relays 1 - 4 are normally off and can be assigned as alarm or tripping relays to the power functions which can either be done by using the push buttons on the front plate or via serial interface RS485. The assignment of the output relays is similar to the setting of parameters:

- By pressing push button <SELECT/RESET> in blocking mode again, the assignment mode is selected.

Definition:

Alarm relays are activated at pickup.

Tripping relays are only activated after elapse of the tripping delay.

The relays are assigned as follows:

- LEDs P>, P< and Pr are two-coloured and light up **green** when the output relays are assigned as **alarm relays** and **red** as **tripping relays**.
- After the assignment mode has been activated, first LED P> lights up green. Now one or several of the four output relays can be assigned to power element P> as alarm relays.
- Indication "1 _ _ _" means that output relay 1 is assigned to this power element. When the display shows " _ _ _ _", no alarm relay is assigned to this power element.
- The assignment of output relays 1 - 4 to the power elements can be changed by pressing <+> and <-> push buttons.
- The selected assignment can be stored by pressing push button <ENTER> and subsequent input of the password.
- By pressing push button <SELECT/RESET>, LED I> lights up red. The output relays can now be assigned to this power element as tripping relays. Relays 1 - 4 are selected in the same way as described before.
- By repeatedly pressing of the <SELECT/RESET> push button and assignment of the relays all elements can be assigned separately to the relays.

The blocking and assignment mode can be terminated at any time by pressing the <SELECT/RESET> push button for some time (abt. 3 s).

Note:

- The function of jumper J2 described in general description "MR Digital Multifunctional Relays" has no function. For relays without assignment mode this jumper is used for parameter setting of alarm relays (activation at pickup or tripping).
- A form is attached to this description where the setting requested by the customer can be filled-in. This form is prepared for telefax transmission and can be used for your own reference as well as for telephone queries.

Relay function	Output relays				Display-indication	Lighted LED
	1	2	3	4		
P> alarm tripping	X	X			_ 2 _ _ 1 _ _ _	P>: green P>: red
P< alarm tripping	X	X			_ 2 _ _ 1 _ _ _	P<: green P<: red
Pr alarm tripping	X		X		_ _ 3 _ 1 _ _ _	Pr: green Pr: red
U<Pr alarm tripping	X		X		_ _ 3 _ 1 _ _ _	U<Pr: green U<Pr: red
t _{CBFP} tripping				X	_ _ _ 4	

Table 5.4: Example of assignment matrix of the output relay (default settings).

5.3 Indication of measuring values and fault data

5.3.1 Indication of measuring values

During normal service, the following measuring values of the **MRP2-3** can be indicated:

- Total three-phase active power (LEDs L1, L2, L3 green)
- Active power in phase L1 (LED L1 green)
- Active power in phase L2 (LED L2 green)
- Active power in phase L3 (LED L3 green)

In star-connection only:

- Phase-to-neutral voltage in phase L1 (LED U and L1 green)
- Phase-to-neutral voltage in phase L2 (LED U and L2 green)
- Phase-to-neutral voltage in phase L3 (LED U and L3 green)

In delta-connection only:

- Phase-to-phase voltage U12 (LED U, L1, L2 green)
- Phase-to-phase voltage U23 (LED U, L2, L3 green)
- Phase-to-phase voltage U31 (LED U, L1, L3 green)

Phase currents:

- Current in phase 1 (LED I and L1 green)
- Current in phase 2 (LED I and L2 green)
- Current in phase 3 (LED I and L3 green)

The following measuring values of the **MRP2-1** can be indicated during normal service:

- Total three-phase active power (LED P green)

In star connection:

- phase-to-neutral voltage (LED U green)

In delta connection:

- phase-to-phase voltage (LED U green)
- phase current (LED I green)

5.3.2 Indication of fault data

All faults detected by the relay are indicated on the front plate optically. For this purpose, the four LEDs (L1, L2, L3, $\rightarrow\leftarrow$) and the four function LEDs (P>, P<, Pr, $U_{<Pr}$) are equipped at **MRP2** and **MRP2-R1**. If, for example a reverse power occurs, first the LEDs L1, L2, L3 will light up. LED Pr lights up at the same time. After tripping the LEDs are lit permanently.

At unit **MRP2-1** and **MRP2-R1** the two LEDs (P, $\rightarrow\leftarrow$) and the four functional LEDs (P>, P<, Pr, $U_{<Pr}$) are equipped to display the detected fault data.

5.3.3 Fault Recorder

When the relay is energized or is energized or trips, all fault data and times are stored in a non-volatile memory manner. The **MRP2** is provided with a fault value recorder for max. eight fault events. In the event of additional trippings always the oldest data set is written over.

For fault indication not only the trip values are recorded but also the status of LEDs. Fault values are indicated when push buttons <-> or <+> are pressed during normal measuring value indication.

- Normal measuring values are selected by pressing the <SELECT/RESET> button.
- When then the <-> button is pressed, the latest fault data set is shown. By repeated pressing the <-> button the last but one fault data set is shown etc. For indication of fault data sets abbreviations FLT1, FLT2, FLT3, ... are displayed (FLT1 means the latest fault data set recorded).
- By pressing <SELECT/RESET> the fault measuring values can be scrolled.
- By pressing <+> it can be scrolled back to a more recent fault data set. At first FLT8, FLT7, ... are always displayed. When fault recording is indicated (FLT1 etc), the LEDs flash in compliance with the stored trip information, i.e. those LEDs which showed a continuous light when the fault occurred are now blinking to indicate that it is not a current fault. LEDs which were blinking during trip conditions, (element had picked up) just briefly flash.
- If the relay is still in trip condition and not yet reset (TRIP is still displayed), no measuring values can be shown.
- To delete the trip store, the push button combination <SELECT/RESET> and <-> has to be pressed for about 3 s. The display shows 'wait'.

Recorded fault values at MRP2-3:

Indicated quantity	corresponding LED	Unit
Total power	L1, L2, L3	[x P _N]
Power in phase L1, L2, L3 *	L1, L2, L3	[x P _N]
Phase-to-phase voltage in delta connection	L1/L2, U L2/L3, U L3/L1, U	[V]
Phase-to-neutral voltage in Y connection	L1, L2, L3, U	[V]
Phase currents L1, L2, L3	L1, L2, L3, I	[x I _N]
C.B. tripping time ¹⁾		[s]

* only in Y connection

Recorded fault values at MRP2-1:

Indicated quantity	corresponding LED	Unit
Total power	P	[x P _N]
Phase-to-phase voltage in delta connection	U	[V]
Phase-to-neutral voltage in Y connection	U	[V]
Phase current	I	[x I _N]
C.B. tripping time ¹⁾		[s]

¹⁾ C.B. tripping time:
Time between pickup and release of the low set element. This value is only displayed for <1% x I_N

5.4 Reset

Unit *MRP2* has the following three possibilities to reset the display of the unit as well as the output relays at jumper position J3=ON.

Manual Reset

- Pressing the push button <SELECT/RESET> for some time (about 3 s).

Electrical Reset

- Through applying auxiliary voltage to C8/D8.

Software Reset

- The software reset has the same effect as the <SELECT/RESET> push button (see also communication protocol of RS485 interface).

The display can only be reset when the pickup is not present anymore (otherwise "TRIP" remains in display).

During resetting of the display the parameters are not affected.

5.5 Hints for the setting procedure

5.5.1 Setting of the power measuring circuits switching point

The fact that the relay has to pickup for example at an alternator reverse power of 5% does not necessarily mean that the setting value of the **MRP2** is also 5%. Due to the transformer ratio, the switchpoints' setting value must first be calculated.

Calculation of the setting value

Necessary data:

P_{GEN} [kW] Active power of the generator in kW
it is calculated from the apparent power of the generator S_{GEN} according to:
 $P_{GEN} = S_{GEN} \cdot \cos \varphi$

P_{MRP2} [kW] Reference power of the **MRP2** in kW
It is calculated from
 I_N Nominal current of the relay
 U_N Nominal voltage of the relay
 n_I Ratio of the current transformer
 n_U Ratio of the voltage transformer
for 4 wire system according to

$$P_{MRP2} = \sqrt{3} \times I_N \times U_N \times n_I \times n_U$$

with U_N = phase to phase voltage

If P_{REV} [%] is the desired reverse-power value in % referring to the active power of the generator, then the value to be adjusted on the relay is calculated as per following formula:

$$\text{adjustment value in \%} = \frac{P_{GEN} \text{ [kW]}}{P_{MRP1} \text{ [kW]}} \cdot P_{REV} \text{ [%]}$$

Calculation-example 1

active power of the generator
 $P_{GEN} = 625 \text{ kVA} \times 0.8 = 500 \text{ kW}$
rated current of **MRP2** $I_N = 5 \text{ A}$
rated voltage of **MRP2** (phase-to-phase voltage) $U_N = 400 \text{ V}$
ratio of the current transformer $n_I = 1000 \text{ A} / 5 \text{ A} = 200$
 \Rightarrow reference power of the unit

$$P_{MRP2} = \sqrt{3} \times 5 \text{ A} \times 400 \text{ V} \times 200 = 690 \text{ kW}$$

If the relay should respond at a reverse power of 5% the adjustment value can be calculated in the following way:

$$\text{adjustment value (\% of scale)} = \frac{500 \text{ kW}}{690 \text{ kW}} \times 5\% = 3.62\%$$

In the previous example the relay **MRP2** has to be adjusted to 4%, so that it responds to a generator reverse-active power of 5%. The more sensitive relay version **MRP2-R** can be adjusted to 3.7%

Calculation example 2

active power of the generator
 $P_{GEN} = 1875 \text{ kVA} \times 0.8 = 1500 \text{ kW}$
nominal current of **MRP2** $I_N = 5 \text{ A}$
nominal voltage of **MRP2** (phase-to-phase voltage) $U_N = 100 \text{ V}$
Ratio of current transformer $n_I = 150 \text{ A} / 5 \text{ A} = 30$
voltage transformer $n_U = 10 \text{ kV} / 100 \text{ V} = 100$
 \Rightarrow reference voltage of the unit

$$P_{MRP2} = \sqrt{3} \times 5 \text{ A} \times 100 \text{ V} \times 30 \times 100 = 2598 \text{ kW}$$

If the relay should pickup at reverse power greater than 3% (referred to the active power of the generator) the adjustment value can be calculated in the following way:

$$\text{adjustment value \%} = \frac{1500 \text{ kW}}{2598 \text{ kW}} \times 3\% = 1.73\%$$

In the foregoing example the relay **MRP2** has to be adjusted to 2%.

The more sensitive relay version **MRP2-R** can be adjusted to 1.8%.

6 Relay Testing and commissioning

The following test instructions should help to verify the protection relay performance before or during commissioning of the protection system. To avoid a relay damage and to ensure a correct relay operation, be sure that:

- the auxiliary power supply rating corresponds to the auxiliary voltage on site.
- the rated current and rated voltage of the relay correspond to the plant data on site.
- the current transformer circuits and voltage transformer circuits are connected to the relay correctly.
- all signal circuits and output relay circuits are connected correctly.

6.1 Power-On

NOTE!

Prior to switch on the auxiliary power supply, be sure that the auxiliary supply voltage corresponds with the rated data on the type plate.

Switch on the auxiliary power supply to the relay and check that the message "| SEG" appears on the display and the self supervision alarm relay (watchdog) is energized (Contact terminals D7 and E7 closed).

6.2 Testing the output relays

NOTE!

Prior to commencing this test, always block the output circuits or interrupt in another way the output circuits which can cause the tripping of the circuit breaker if the breaker operation during this test is not desired.

By pressing the push button <TRIP> once the display shows you the first part of the software version of the relay (e.g. „D08-“). By pressing the push button <TRIP> twice the display shows the second part of the software version of the relay (e.g. „4.01“). The software version should be quoted in all correspondence. After you have got a message "PSW?" on the display by pressing the push button <TRIP> once more please enter the correct password to proceed with the test. After that the message "TRI?" will follow. Confirm this testing by means of pressing push button <TRIP> again. All output relays should then be activated and the self supervision alarm relay (watchdog) be deactivated one after another with a time interval of 1 second. Thereafter, reset all output relays by pressing the push button <SELECT/RESET>.

6.3 Checking the set values

As input energizing quantities for three phase power relay **MRP2-3**, three phase voltages and currents will be applied to relay input circuits.

By repeatedly actuating the push button <SELECT> all relay set values may be checked. For detailed information, please refer to chapter 5.

Depending on the system conditions and the voltage transformer used, three phase voltages can be connected to the relay input circuits with either star or delta connection. In case of a star connection the phase-to-neutral voltage will be applied to the voltage input circuits, while the phase-to-phase voltages will be connected to the voltage input circuits in case of a delta connection. The voltage input connection can be set as a parameter, and should agree with the actual voltage input connection:

Y: Star connection. Phase-to-neutral voltages will be measured and evaluated.

Delt: Delta connection. Phase-to-phase voltages will be measured and evaluated.

Phase-to-phase voltages or phase-to-neutral voltage will be connected to the relay MRP2-1 when changeover star/delta correction.

NOTE!

For single phase power relay **MRP2-1**, if delta connection is chosen, current in phase 1 (I_{L1}) should be connected to input terminals B3/B4 and phase-to-phase voltage between phase 1 and phase 2 (U_{12}) should be connected to input terminals A3/A4. If star connection is chosen, the current in phase 1 (I_{L1}) should be connected to input terminals B3/B4 and phase-to-neutral voltage between phase 1 and neutral (U_{1E}) should be connected to input terminals A3/A4.

6.4 Secondary injection test

6.4.1 Test equipment

- Voltmeter, ammeter and wattmeter with class 1 or better
- Auxiliary power supply with the voltage corresponding to the rated data on the type plate
- Single-phase or three-phase current supply unit (adjustable from 0 to $2 \times I_n$)
- Single-phase or three phase voltage supply unit (adjustable from 0 to $1.2 \times U_n$)
- Timer to measure the operating time (Accuracy class 10 ms)
- Switching device
- Test leads and tools

6.4.2 Example of test circuit for MRP2 relay

For testing power relays, you need both current and voltage input signals with adjustable phase shifting. Figure 1 shows an example of a single phase test circuit with adjustable voltage and current energizing the **MRP2** relay under test.

For testing the power relay, the input voltage shall be applied to the relay with a constant value within its effective range ($U = U_n$ or $U = U_n/\sqrt{3}$). The input current and phase angle shall be appropriately varied. In figure 6.1 the relay voltage connection is supposed to be set to star connection and a single phase test circuit will be used to test a three phase power relay **MRP2-3** or a single phase power relay **MRP2-1**.

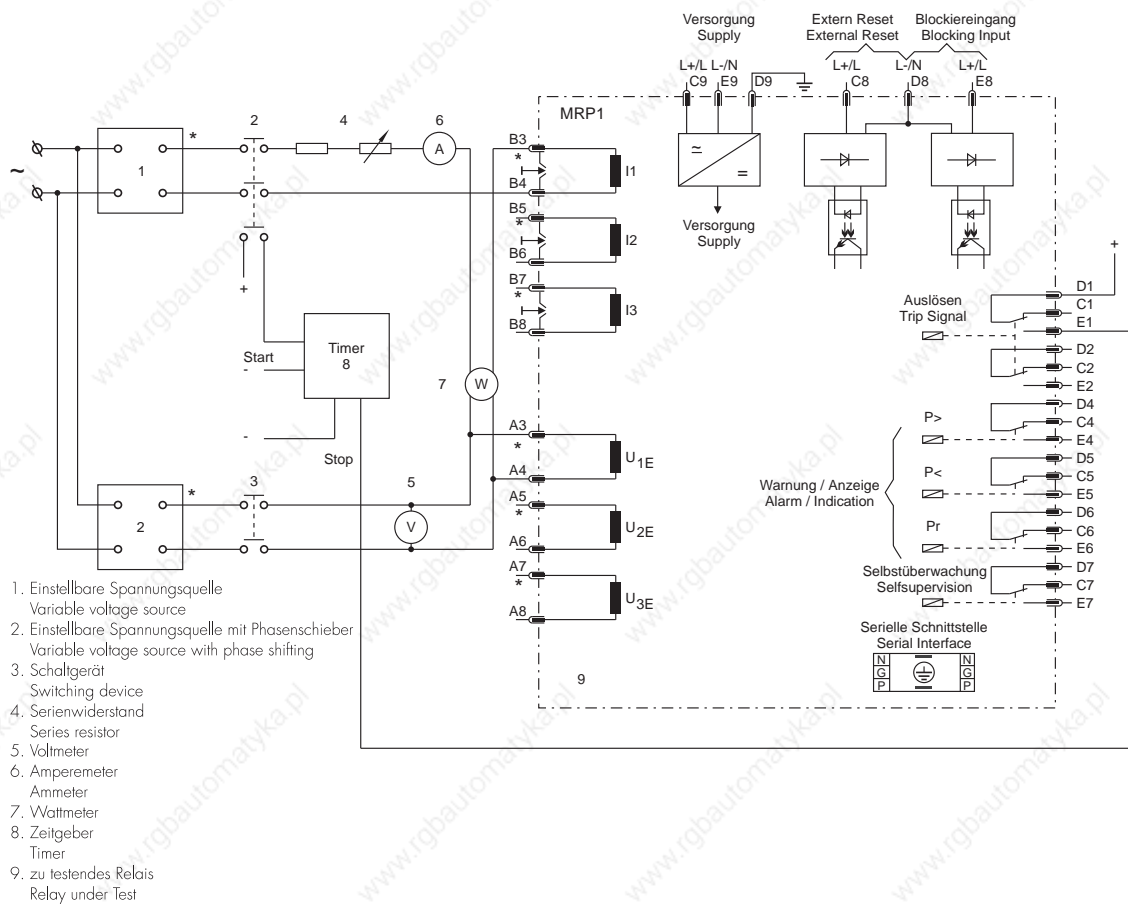

Fig. 6.1: Test circuit

Great care must be taken as to connect the test current and test voltage to the relay in correct polarity. In figure 6.1 the relay and test source polarity are indicated by a * mark near the terminals. The markings indicate that the relay will measure a forward active power when the voltage drops from polarity to non-polarity in the voltage input circuit and the current flows from polarity to non-polarity in the current input circuit in case of a unity power factor.

The power at MRP2-1 (Δ -setting) will be calculated as follows:

$P_{Tot} = I_1 \times U_{12} + I_3 \times U_{32}$, this means: phase 2 is used as reference current.

Meanwhile the displayed power will not be changed if current I_2 changes.

6.4.3 Checking the input circuits and measured values

The active power measured by *MRP2* is related to the rated power of the relay P_N :

$$P_N = 3 \cdot \frac{U_N}{\sqrt{3}} \cdot I_N$$

Inject a current of rated value (1A for $I_N = 1A$) in phase 1 (terminals B3-B4) and apply a voltage of $U_N/\sqrt{3}$ to terminals A3/A4. The input voltage and current should be in phase (unity power factor). Check the measured power, voltage and current on the display by pressing the push button <SELECT>. The power to be measured in this case should be $0.33 \times P_N$ for three phase power relays *MRP2-3* and $1.00 \times P_N$ for single phase power relays *MRP2-1* respectively. The voltage to be measured is $U_N/\sqrt{3}$ and current to be measured $1 \times I_N$.

Exchange the current input terminals B3/B4. The power to be measured in this case should be $-0.33 \times P_N$ for three phase power relays *MRP2-3* and $-1.00 \times P_N$ for single phase power relays *MRP2-1*. The voltage to be measured is $U_N/\sqrt{3}$ and current to be measured $1 \times I_N$.

Compare the values of current, voltage and power shown in display with the measured values of ammeter, voltmeter and active power meter. The deviations of current and voltage measurement must not exceed 5%. The deviation of active power measurement must not exceed 3%.

If possible, perform the test for different phase angles and check the active power to be measured.

6.4.4 Checking the operating and resetting values of the relay

Apply rated voltage on input terminals A3/A4.

Gradually increase (decrease) the current in phase 1 until the relay starts, i.e. at the moment when the LED P> (or P<) lights up or the alarm output relay P> (or P<) is activated. Read-off the operating active power from wattmeter. The deviation must not exceed 5% of the set operating value under the condition of reactive part < 50%.

Furthermore, gradually decrease (increase) the current until the relay resets, i.e. the alarm output relay P> (or P<) is de-energized.

For ascertaining the resetting value, increase (decrease) gradually the test current until the output relay P> (P<) de-energizes. For overload the resetting value must be >97%. For P< the value must be <103%.

Checking the operating and resetting values at reverse power

This test can be done similarly, only CT terminals B3/B4 have to be changed. Lighting up of LED Pr and energizing of alarm output relay Pr (terminals D6/E6) have to be observed. Values displayed to be negative in sign.

Checking the operating and resetting values at voltage-dependent reverse power

When the reverse power element is excited (see above), the measuring voltage is decreased. If the voltage-dependent reverse power element picks up, lighting-up of the LED, tripping of the jumpered alarm and tripping relays as well as the voltage value at tripping must be checked.

6.4.5 Checking the relay operating time

To check the relay operate time, a timer to is be connected to the trip relay contact. The timer should be started simultaneously with the current injection in the current input circuit and stopped by the trip relay contact. Apply rated voltage to the relay and set the current to a value corresponding to twice the operate value and inject the current instantaneously. The operate time measured by timer should have a deviation <3% of the set value or 20 ms.

Repeat the test on all phases and for all relay functions (Over-power P>, Under-power P< and Reverse power Pr) in the same manner.

6.4.6 Test of the CB failure protection

For testing the tripping time the rated voltage has to be applied and a test current of about 2 times the rated current to be injected. The timer is started upon tripping of the relay of a protection function (P<, P>, P) and stopped as soon as the relay for the CB failure protection has picked up. Message "CBFP" is displayed. The tripping time ascertained by the timer should not deviate more than 1% or, at short trip delay, less than 10 ms from the set tripping time. Alternatively, the timer can be started when the aux. voltage and the test current are injected simultaneously. The timer stops when the corresponding output relay for circuit breaker failure protection trips. In this case the previously measured tripping delay (see section 6.4.5) has to be subtracted from the total tripping time measured.

6.4.7 Checking the external blocking and reset functions

At **MRP2** relays, all relay functions will be inhibited by external blocking input. To test the blocking function: Apply auxiliary supply voltage to the external blocking input of the relay (terminals E8/D8). Apply a test voltage and inject a test current which could cause a tripping. Observe that there is no trip and alarm.

Remove the auxiliary supply voltage from the blocking input. Apply a test voltage and inject a test current to make the relay tripped (Message „TRIP“ on the display). Interrupt the test current and apply auxiliary supply voltage to extern reset input of the relay (terminals C8/D8). The display and LED indications should be reset immediately.

6.5 Primary injection test

Generally, a primary injection test could be carried out in the similar manner as the secondary injection test above described. With the difference that the protected power system should be, in this case, connected to the installed relays under test „on line“, and the test currents and voltages should be injected to the relay through the current and voltage transformers with the primary side energized. Since the cost and potential hazards are very high for such a test, especially if staged fault tests are intended, primary injection tests are usually limited to very important protective relays in the power system.

Because of its powerful combined indicating and measuring functions, you have still the possibilities to test the **MRP2** relay in the manner of a primary injection without extra expenditures and time consumption. In actual service, for example, the measured current and voltage values as well as the measured active power value may be compared phase by phase with the measuring devices on the switch-board panel to verify that the relay works and measures correctly and to verify that the relay is connected to the power system with the correct polarity.

6.6 Maintenance

Maintenance testing is generally done on site at regular intervals. These intervals vary among users depending on many factors: e.g. the type of protective relays employed; the importance of the primary equipment being protected; the user's past experience with the relay, etc.

For electromechanical or static relays, maintenance testing will be performed at least once a year according to the experiences. For digital relays like **MRP2**, this interval can be substantially longer. This is because that:

- the **MRP2** relays are equipped with very wide self-supervision functions, so that many faults in the relay can be detected and signalized during the service. Important: The self-supervision output relay must be connected to a central alarm panel!
- the combined measuring functions in **MRP2** relay enable supervision the relay functions during service.
- the combined TRIP test function of the **MRP2** relay allows to test the relay output circuits by power system interrupt.

A testing interval of two years for maintenance will, therefore, be recommended.

During a maintenance testing, the relay functions including the operating values and relay tripping characteristics as well as the operating time should be tested.

7 Technical data

For further information please refer to description "MR-Digital Multifunctional Relays".

7.1 Measuring input circuits

Rated data:	Rated current I_N :	1 A or 5 A
	Rated voltage U_N :	100 V, 230 V, 400 V
	Rated frequency f_N :	40 - 70 Hz
Max. measuring range:	$2 \times I_N$ (MRP2)	$0.5 \times I_N$ (MRP2-R)
	$1.5 \times U_N$ at $U_N = 100 \text{ V}, 230 \text{ V}$	
	$1.25 \times U_N$ at $U_N = 400 \text{ V}$	
Power consumption in current circuit:	at $I_N = 1 \text{ A}$	0.2 VA
	at $I_N = 5 \text{ A}$	0.1 VA
Power consumption in voltage circuit:	< 1 VA per phase at U_N	
Thermal withstand capability in current circuit:	dynamic current withstand (half-wave)	$250 \times I_N$
	for 1 s	$100 \times I_N$
	for 10 s	$30 \times I_N$
	continuously	$4 \times I_N$
Thermal withstand capability in voltage circuit:	continuously	$1.5 \times U_N, 1.5 \times U_N$ at $U_N = 100 \text{ V}, 230 \text{ V}$ $1.25 \times U_N = 400 \text{ V}$
Accuracy of measuring:	P_N :	3% of measuring value or 0.5% of rated value
	U_N :	5% of measuring value or 1% of rated value
	I_N :	5% of measuring value or 1% of rated value
Additional inaccuracy of angle measuring at rated voltage:	$\pm 2^\circ$ corresponds to $\cos\varphi=0,8$	$\alpha=37^\circ \pm 2,6\%$ of rated value
	$\cos\varphi=0,707$	$\alpha=45^\circ \pm 3,5\%$ of rated value
	$\cos\varphi=0,5$	$\alpha=60^\circ \pm 6,1\%$ of rated value

7.2 Common data

Dropout to pickup ratio:	>97% for $P>$ and P_r and < 103% for $P<$
Returning time:	30 ms
Time lag error class E:	± 10 ms
Minimum operating time:	30 ms
Influences of power measuring Auxiliary voltage:	in the range of $0.8 < U_H / U_{HN} < 1.2$ no additional influences can be measured
Frequency:	no influence
Influences on delay times:	no additional influences can be measured

7.3 Setting ranges and steps

7.3.1 Setting ranges and steps MRP2-1 and MRP2-3

Function	Parameter	Setting range	Steps	Tolerance
P>	P>	0.005...2.0 x P _N ; EXIT	0.005; 0.01; 0.02 x P _N	refer to 7.1
	t _{P>}	0.04...120 s; EXIT	0,02; 0.01; 0,1; 0,2; 0,5; 1,0; 2,0 s	±1% or ±10 ms
P<	P<	EXIT; -0.1...2.0 x P _N	0.005; 0.01; 0.02 x P _N	refer to 7.1
	t _{P<}	0.04...120 s; EXIT	0.02; 0.05; 0.1; 0.2; 0.5; 1.0; 2.0 s	±1% or ±10 ms
Pr	Pr	0.005...2.0 x P _N ; EXIT	0.005; 0.01; 0.02 x P _N	refer to 7.1
	t _{Pr}	0.04... 120 s; EXIT	0.02; 0.05 0.1; 0.2; 0.5; 1.0; 2.0 s	±1% or ±10 ms
U<Pr	U<Pr	U _N = 100 V 2...150 V (EXIT) U _N = 230 V 4...346 V (EXIT) U _N = 400 V 10...600 V	1 V 2 V 5 V	±1% from setting value or < 1% U _n
	t _{U<Pr}	0.04... 120 s; EXIT	0.01; 0.02; 0.05; 0.1; 0.2; 0.5; 1.0; 2.0 s	±1% or ±10 ms
t _{CBFP}	t _{CBFP}	0,1...1,6 s; EXIT	0,01; 0,02; 0,05; 0,1 s	±1% bzw. ±10 ms

Table 7.1: Setting ranges and steps MRP2-1 and MRP2-3

7.3.2 Setting ranges and steps MRP2-R1 and MRP2-R3

Function	Parameter	Setting range	Step	Tolerance
P _{>}	P _{>}	0.001...0.5 x P _N ; EXIT	0.001; 0.002; 0.005 x P _N	refer to 7.1
	t _{P>}	0.04...120 s; EXIT	0,02; 0.01; 0.1; 0.2; 0.5; 1.0; 2.0 s	±1% or ±10 ms
P _{<}	P _{<}	EXIT; -0.1...0.5 x P _N	0.001; 0.002; 0.005 x P _N	refer to 7.1
	t _{P<}	0.04...120 s; EXIT	0.02; 0.05; 0.1; 0.2; 0.5; 1.0; 2.0 s	±1% or ±10 ms
P _r	P _r	0.001...0.5 x P _N ; EXIT	0.001; 0.002; 0.005 x P _N	refer to 7.1
	t _{P_r}	0.04...120 s; EXIT	0.02; 0.05; 0.1; 0.2; 0.5; 1.0; 2.0 s	±1% or ±10 ms
U _{<Pr}	U _{<Pr}	U _N = 100 V 2...150 V (EXIT) U _N = 230 V 4...346 V (EXIT) U _N = 400 V 10...600 V	1 V 2 V 5 V	±1% from setting value or <1% U _n
	t _{U<Pr}	0.04... 120 s; EXIT	0.01; 0.02; 0.05; 0.1; 0.2; 0.5; 1.0; 2.0 s	±1% or ±10 ms
t _{CBFP}	t _{CBFP}	0,1...1,6 s; EXIT	0,01; 0,02; 0,05; 0,1 s	±1% bzw. ±10 ms

Table 7.2: Setting ranges and steps MRP2-R1 and MRP2-R3

7.3.3 Interface parameters

Function	Parameter	Modbus-Protocol	RS485 Open Data Protocol
RS	Slave-Address	1 - 32	1 - 32
RS	Baud-Rate	1200, 2400, 4800, 9600	9600 (fixed)
RS	Parity	even, odd, no	„even Parity“ (fixed)

Table 7.3: Interface parameter

7.4 Output contact ratings

Number of relays:

5

Contacts:

2 relays with 2 change-over contacts

3 relays with 1 change-over contacts

Technical data subject to change without notice!

8 Order form

Directional power relay MRP2-				I		U			
Measuring of reverse power only (2-steps; sensitive)		R							
Power measuring	1-phase		1						
	3-phase		3						
Rated current	1 A				1				
	5 A				5				
Rated voltage:	100 V/110 V						1		
	230 V						2		
	400 V						4		
Housing (12TE)	19"-rack							A	
	Flush mounting							D	
Optionally with Modbus protocol									-M

Setting list *MRP2*

Project: _____ SEG job.-no.: _____

Function group: = _____ Location: ± _____ Relay code: - _____

Relay functions: _____ Password: _____

Date: _____

Function		Unit	Default settings	Actual settings
Δ/Y	input transformer connection		DELTA	
$P>$	pickup value for overload	$\times P_N$	0.005/0.001 ¹	
$t_{P>}$	Tripping delay for overload	s	0.04	
$P<$	Pickup value for underload	$\times P_N$	-0,01/-0.001 ¹	
$t_{P<}$	Tripping delay for underload	s	0.04	
P_r	Pickup value for reverse power	$\times P_N$	0.005/0,001 ¹	
t_{P_r}	Tripping delay for reverse power	s	0.04	
$U_{<P_r}$	Pickup value for undervoltage	V	90/205/360 ²	
$t_{U<P_r}$	Tripping delay for voltage dependent reverse power	s	0.04	
	Tripping delay for C. B. failure protection	s	0,1	
U	Selection of rated voltage	V	100 ³⁾	
	Blocking/release of LED indication after pickup		NOFL	
RS	Slave address of the serial interface		1	
RS ⁴⁾	Transmission rate		9600	
RS ⁴⁾	Parity		even	

¹⁾ *MRP2* or *MRP2-R*

²⁾ dependent from the adjusted rated voltage

³⁾ Only at 100 V version possible

⁴⁾ Only Modbus protocol

Setting of code jumpers

Code jumper	J1		J2		J3	
	Default setting	Actual setting	Default setting	Actual setting	Default setting	Actual setting
Plugged			No function			
Not plugged	X				X	

Assignment of the output relays:

Function	Relay 1		Relay 2		Relay 3		Relay 4	
	Default setting	Actual setting	Default setting	Actual setting	Default setting	Actual setting	Default setting	Actual setting
P> alarm			X					
P> tripping	X							
P< alarm			X					
P< tripping	X							
Pr alarm					X			
Pr tripping	X							
U _{<Pr} alarm					X			
U _{<Pr} tripping	X							
t _{CBFP}							X	

Blocking parameter

Function		Default setting	Actual setting
BLOC	Blockade active/not active	BL=1 (active)	

Assignment of the blocking function:

Function	Default setting		Actual setting	
	Blocking	No blocking	Blocking	No blocking
P>	X			
P<	X			
Pr	X			
U _{<Pr}	X			
CBFP		X		



Woodward SEG GmbH & Co. KG

Krefelder Weg 47 · D – 47906 Kempen (Germany)

Postfach 10 07 55 (P.O.Box) · D – 47884 Kempen (Germany)

Phone: +49 (0) 21 52 145 1

Internet

Homepage <http://www.woodward-seg.com>

Documentation <http://doc.seg-pp.com>

Sales

Phone: +49 (0) 21 52 145 635 · Telefax: +49 (0) 21 52 145 354

e-mail: kemp.electronics@woodward.com

Service

Phone: +49 (0) 21 52 145 614 · Telefax: +49 (0) 21 52 145 455

e-mail: kemp.pd@woodward.com