



HEIDENHAIN

Montageanleitung
Mounting Instructions
Instructions de montage
Istruzioni di montaggio
Instrucciones de montaje

LS 406

LS 476

LS 486

10/2003

Warnhinweise · Warnings · Recommendations · Avvertenze · Advertencias

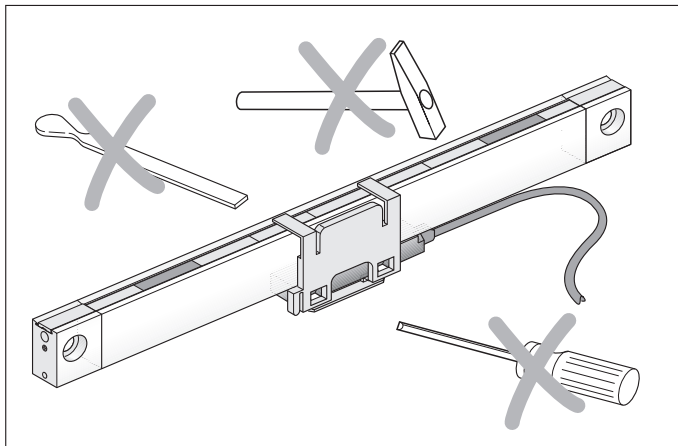
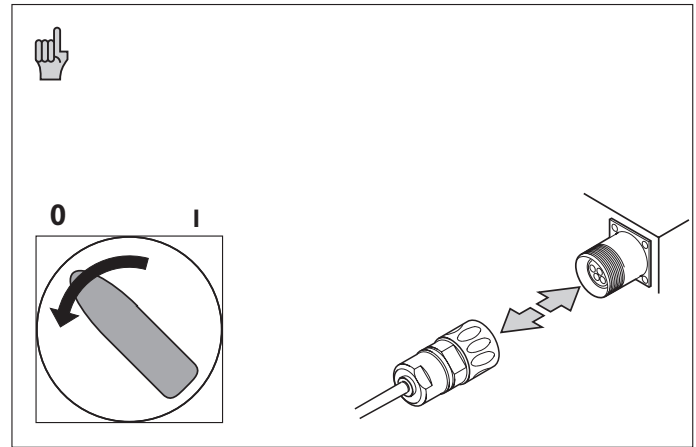
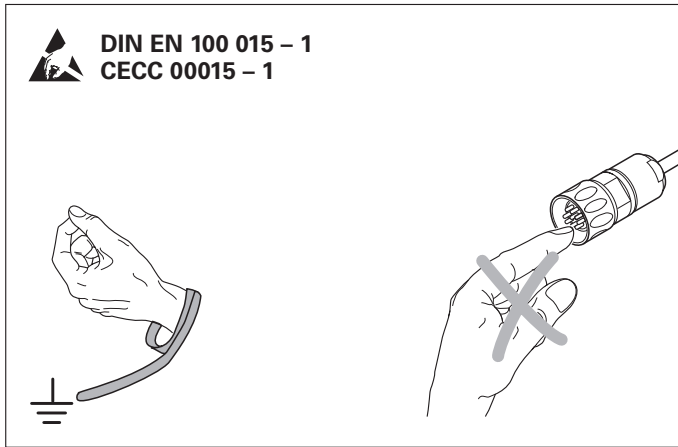

Maße in mm
Dimensions in mm
Cotes en mm
Dimensioni in mm
Dimensiones en mm

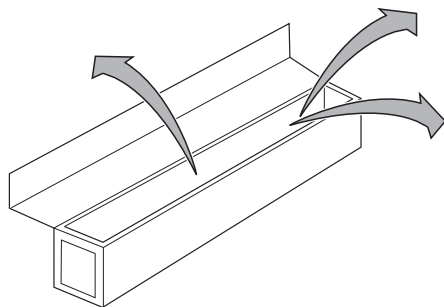
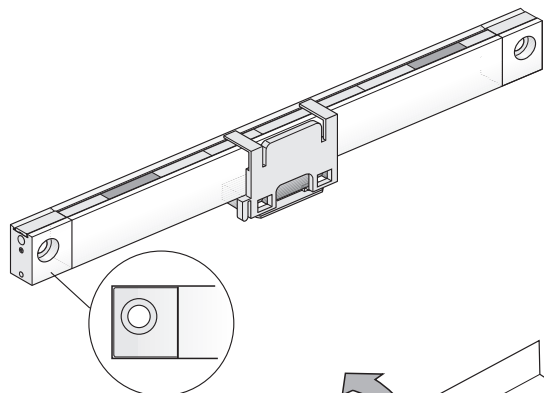

LS 406 (C)
LS 476 (C)
LS 486 (C)

LS 476 (C)
LS 486 (C)

2x
M8x25 DIN 6912

2x
M8x25 ISO 4762

2x
D13.0/8.4

3x
D7.0/4.3

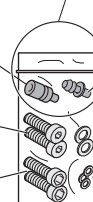

Separat bestellen
Order separately
A commander séparément
Ordinare a parte
Para pedir por separado



Bei Montage bitte Geräteschild-Aufkleber anbringen (Schaltschrank, Maschinen-Handbuch usw.)

Apply the encoder ID label to an appropriate surface, e.g. the electrical cabinet or machine manual

lors du montage, accoler S.V.P. l'étiquette signalétique de l'appareil (armoire électrique, manuel de la machine, etc.)

completato il montaggio, ricordarsi di applicare l'etichetta (manuale della macchina, quadro elettrico)

por favor, durante el montaje, colocar el adhesivo del letrero del aparato (armario eléctrico, modo de empleo de la máquina, etc.)

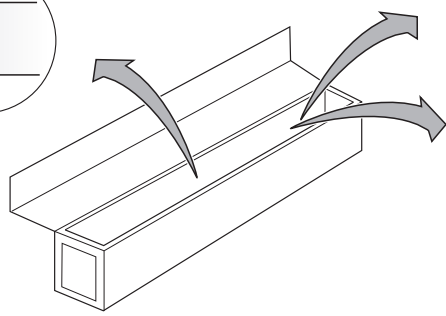
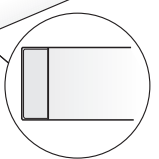
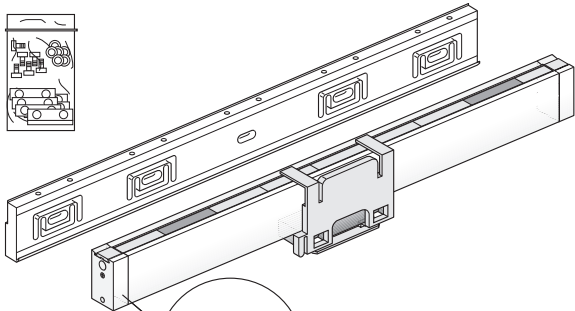
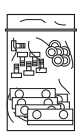

LS 406 (C)
LS 476 (C)
LS 486 (C)

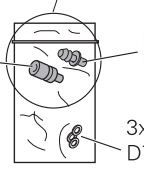

LS 476 (C)
LS 486 (C)

3x
D7.0/4.3



Separat bestellen
Order separately
A commander séparément
Ordinare a parte
Para pedir por separado



Bei Montage bitte Geräteschild-Aufkleber anbringen (Schaltschrank, Maschinen-Handbuch usw.)
Apply the encoder ID label to an appropriate surface, e.g. the electrical cabinet or machine manual
lors du montage, accoler S.V.P. l'étiquette signalétique de l'appareil (armoire électrique, manuel de la machine, etc.)
completato il montaggio, ricordarsi di applicare l'etichetta (manuale della macchina, quadro elettrico)
por favor, durante el montaje, colocar el adhesivo del letrero del aparato (armario eléctrico, modo de empleo de la máquina, etc.)

Kabelanschluss · Cable Connection · Raccordement du cable · Cavo di colleganto · Conexión de cable

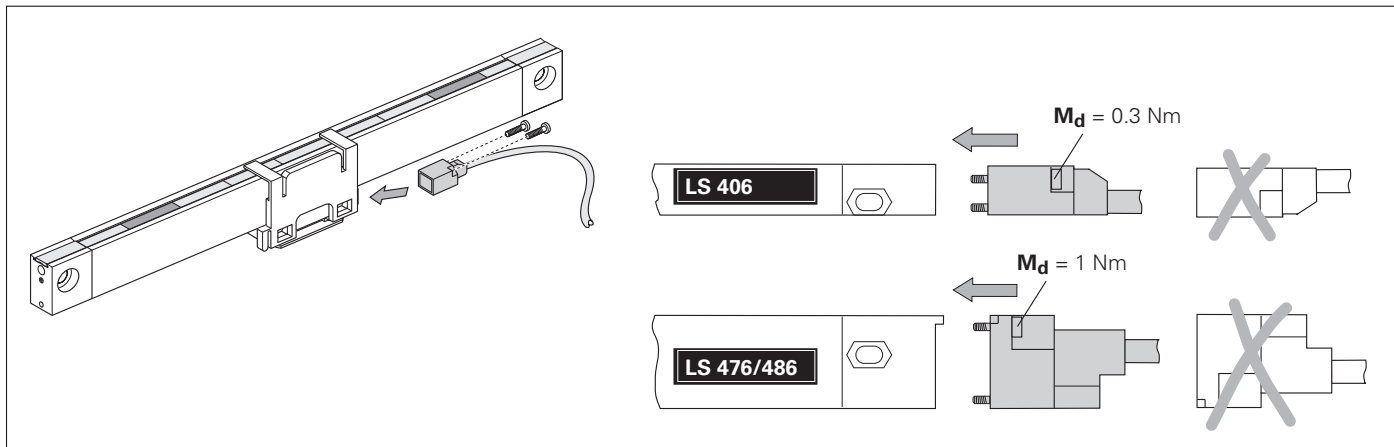

Dichtlippen überprüfen · Inspect Sealing Lips · Contrôler les lèvres d'étanchéité · Controllo delle guarnizioni · Verificar labios

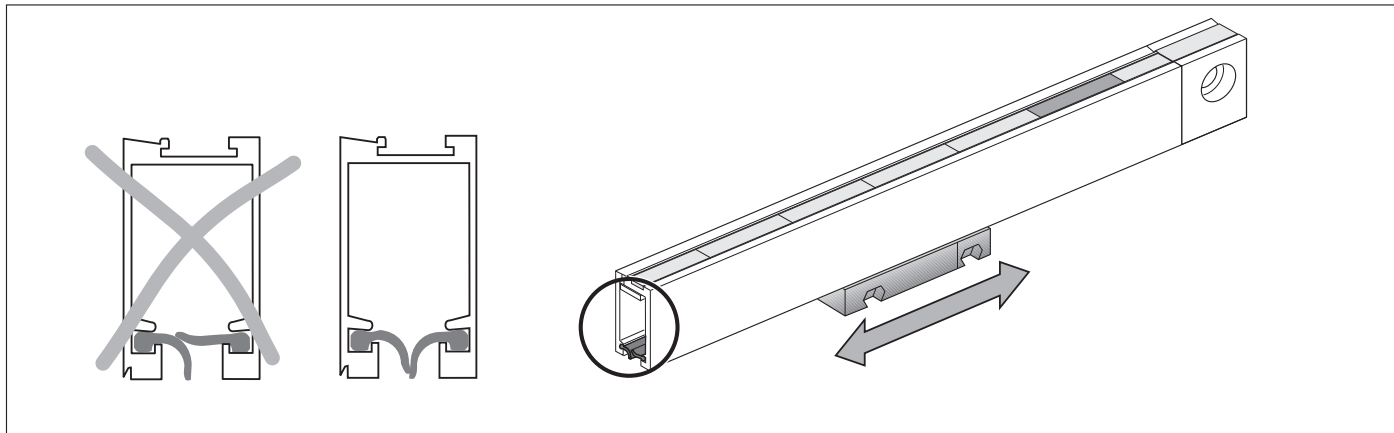

LS 4x6

Referenzmarken-Lage
Reference mark
marque de référence
indici di riferimento
marca de referencia

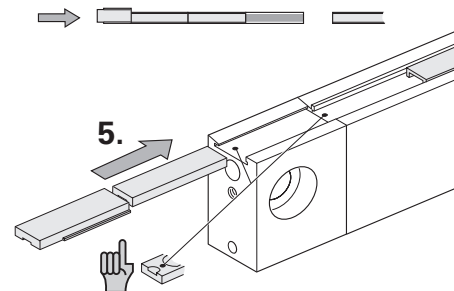
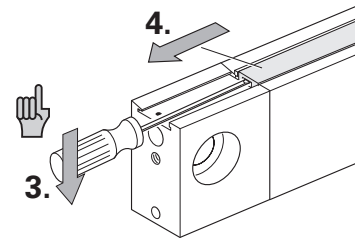
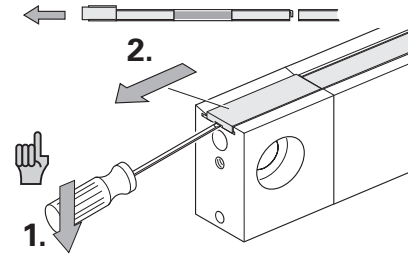
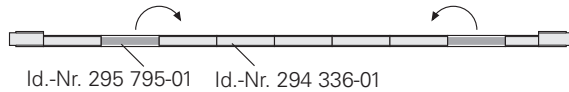
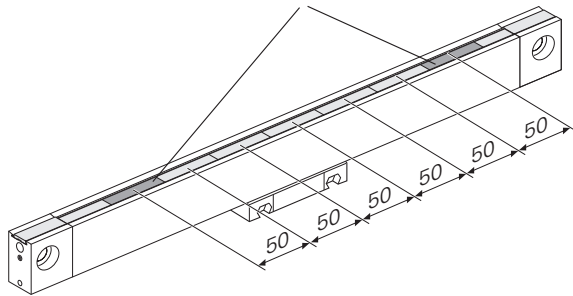

Hinweise zur Montage · *Mounting Procedure* · Procédure pour le montage

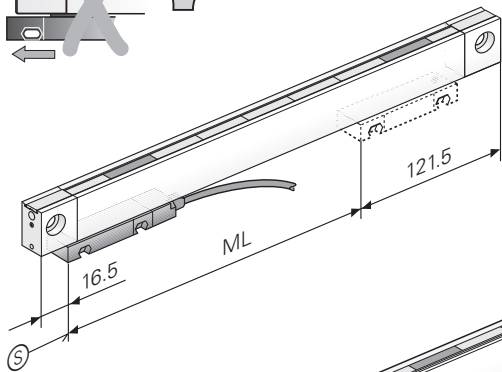
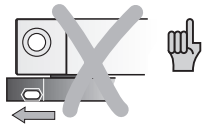

180° gedreht angebaut
Mounted rotated by 180°
Montage avec rotation de 180°
Montaggio ruotato di 180°
Montado girado 180°

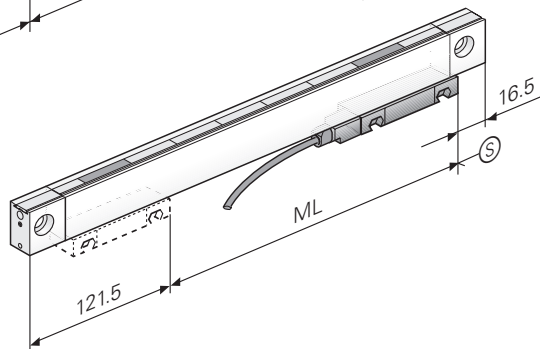

Ⓢ = Beginn der Messlänge ML
Begin. of meas. length ML
début longueur utile ML
inizio lunghezza di misura ML
comienzo longitud útil ML

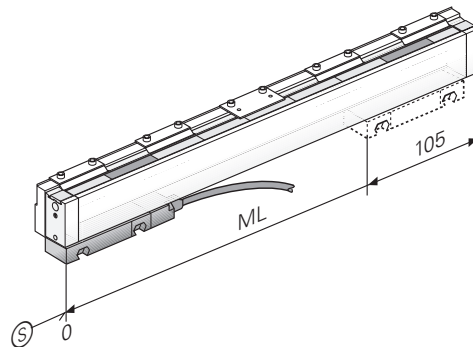

Avvertenze per il montaggio · Indicaciones para el montaje

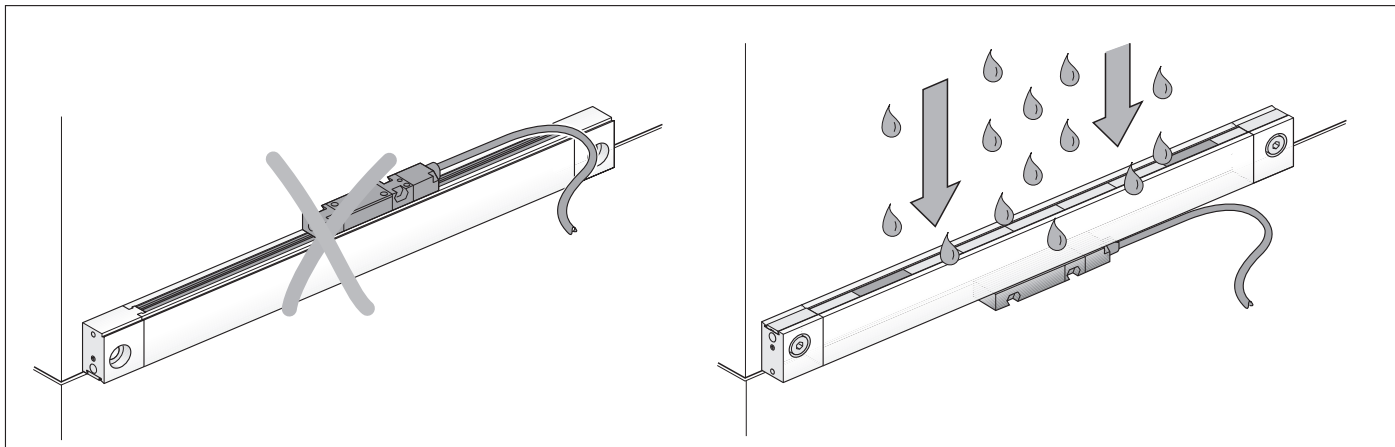

LS 406 (C)

mm



Tolerancing ISO 8015

ISO 2768 - m H

< 6 mm: ±0.2 mm

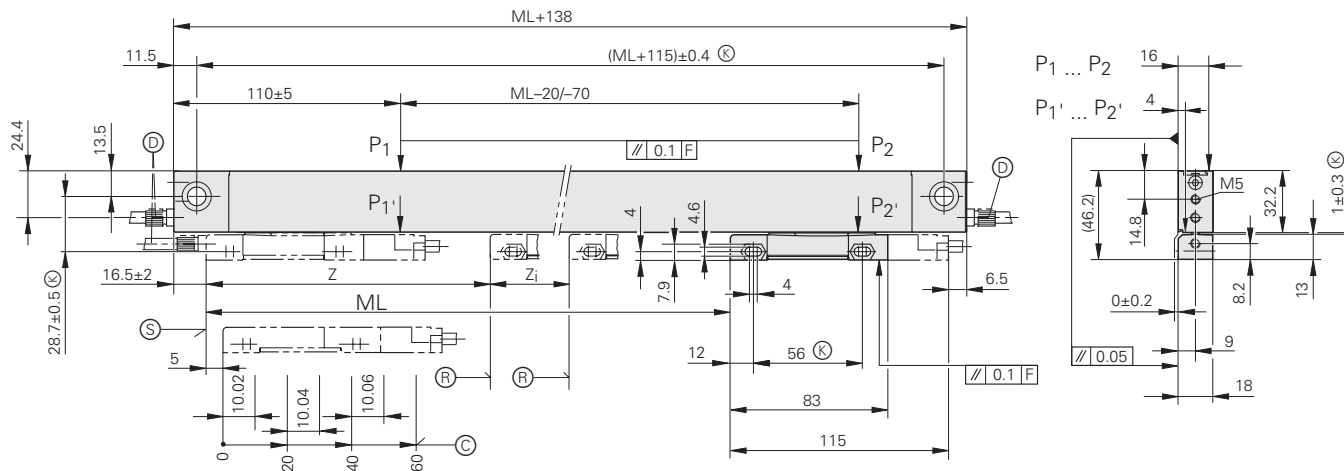
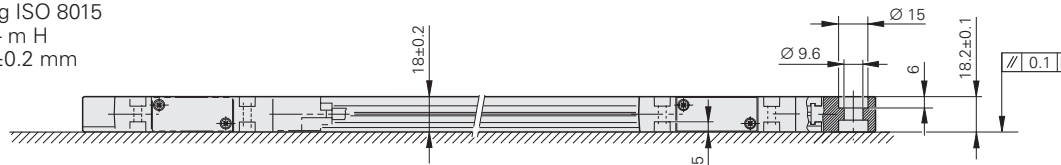

ML 70 ... 1020

ML 1140 ... 1240

z = 35 mm

z = 45 mm

z_i = ML - 70 mm

z_i = ML - 90 mm

P = Messpunkte zum Ausrichten
Gauging points for alignment
points de mesure pour dégauchissage
punti di misura per allineamento
puntos medición alineamiento

Ⓢ = Beginn der Messlänge ML
Begin. of meas. length ML
début longueur utile ML
inizio lunghezza di misura ML
comienzo longitud útil ML

Ⓡ = Referenzmarken-Lage
Reference mark
marque de référence
indici di riferimento
marca de referencia

LS 406 (C)

mm



Tolerancing ISO 8015
ISO 2768 - m H
< 6 mm: ±0.2 mm

ML	m
70 ... 520	0
570 ... 920	1
1020 ... 1340	2
1440 ... 1740	3
1840 ... 2040	4

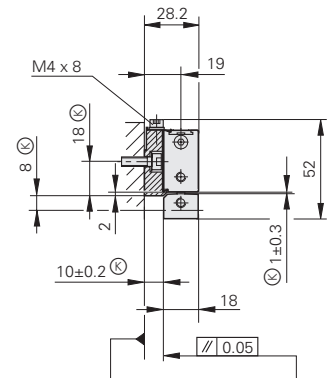
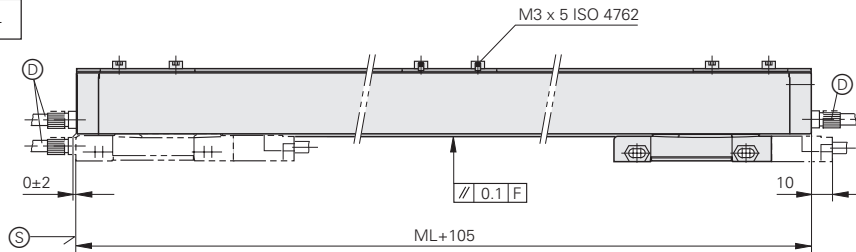
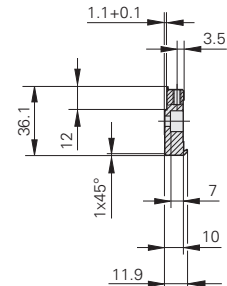
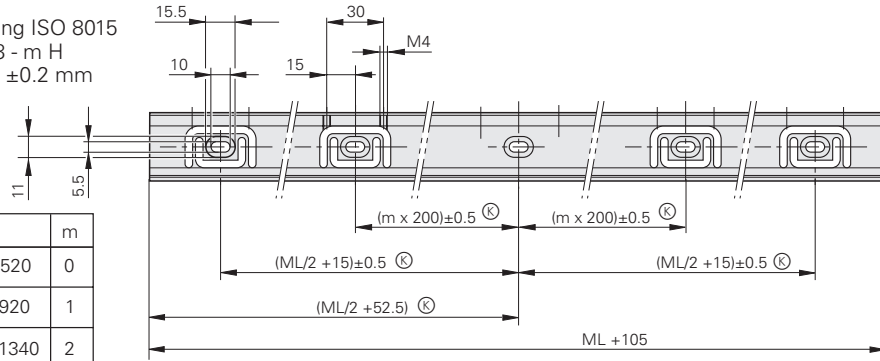

Ⓚ = Kundenseitige Anschlussmaße
Required mating dimensions
conditions requises pour le montage
dimensioni di collegamento lato cliente
cotas de montaje requeridas

F = Maschinenführung
Machine guideway
guidage de la machine
guida della macchina
guía de la máquina

Ⓛ = Druckluftanschluss
Compressed air inlet
raccordement d'air comprimé
ingresso per pressurizzazione
conexión de aire comprimido

LS 476/LS 486 (C)

mm



Tolerancing ISO 8015

ISO 2768 - m H

< 6 mm: ±0.2 mm

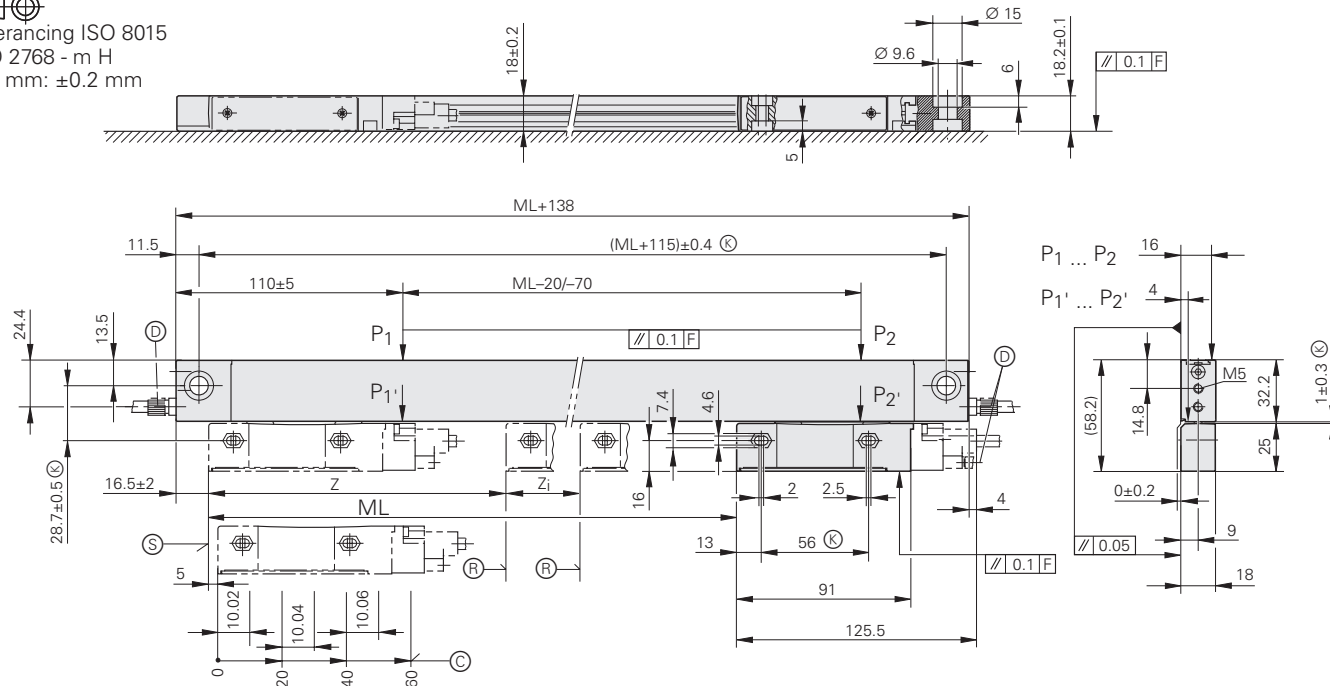

ML 70 ... 1020

ML 1140 ... 1240

z = 35 mm

z = 45 mm

z_i = ML - 70 mm

z_i = ML - 90 mm

P = Messpunkte zum Ausrichten
Gauging points for alignment
points de mesure pour dégauchissage
punti di misura per allineamento
puntos medición alineamiento

Ⓢ = Beginn der Messlänge ML
Begin. of meas. length ML
début longueur utile ML
inizio lunghezza di misura ML
comienzo longitud útil ML

Ⓡ = Referenzmarken-Lage
Reference mark
marque de référence
indici di riferimento
marca de referencia

LS 476/LS 486 (C)

mm



Tolerancing ISO 8015
ISO 2768 - m H
< 6 mm: ±0.2 mm

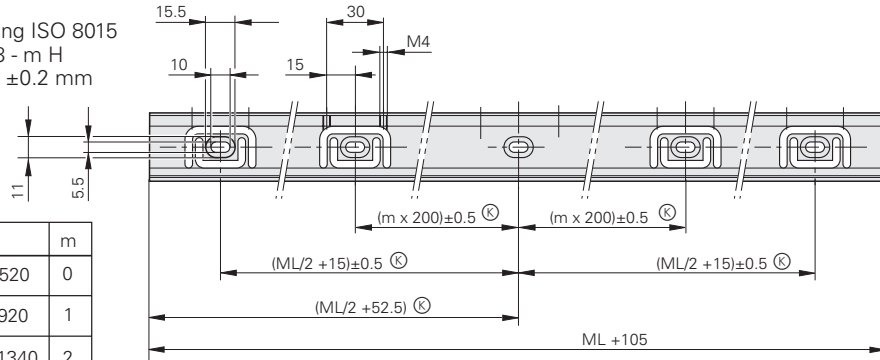

ML	m
70 ... 520	0
570 ... 920	1
1020 ... 1340	2
1440 ... 1740	3
1840 ... 2040	4

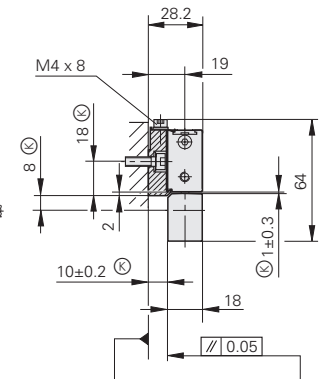
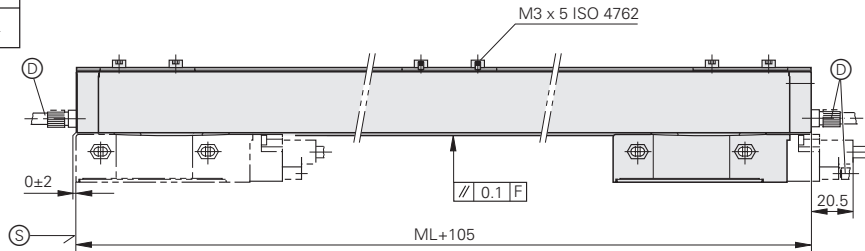
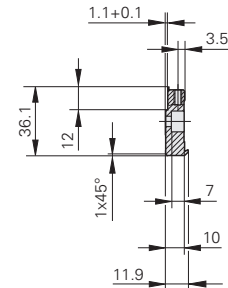

(K) = Kundenseitige Anschlussmaße
Required mating dimensions
conditions requises pour le montage
dimensioni di collegamento lato cliente
cotas de montaje requeridas

F = Maschinenführung
Machine guideway
guidage de la machine
guida della macchina
guía de la máquina

(D) = Druckluftanschluss
Compressed air inlet
raccordement d'air comprimé
ingresso per pressurizzazione
conexión de aire comprimido

Anbau ohne Montageschiene · Mounting without Mounting Spar · Montage sans rail de guidage

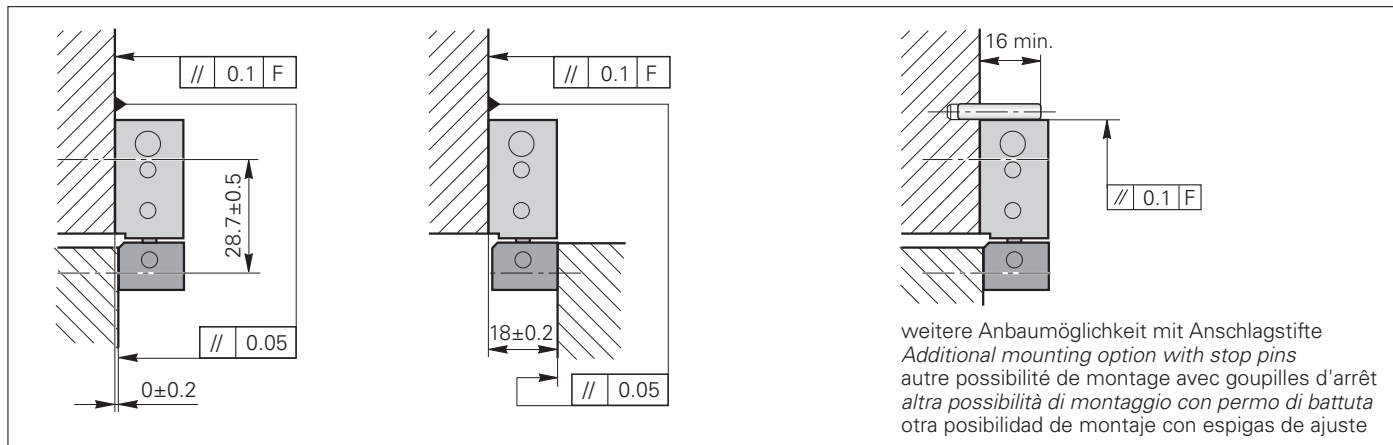
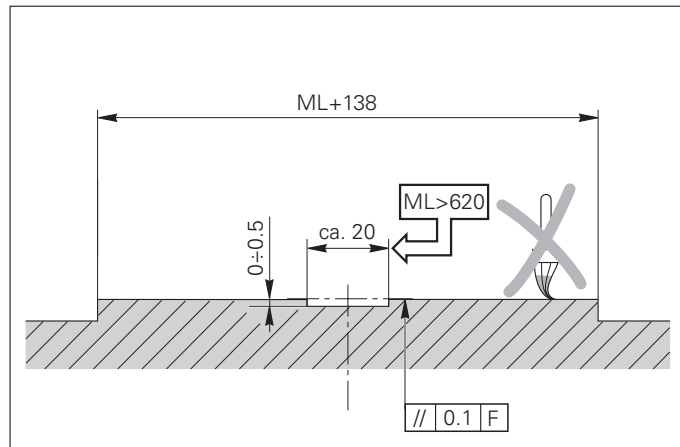
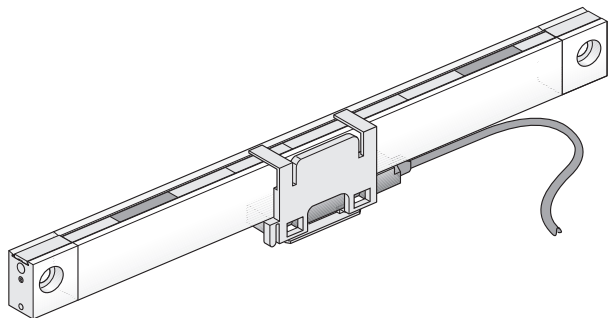

Montaggiosenza guida · Instalación sin guía de montaje

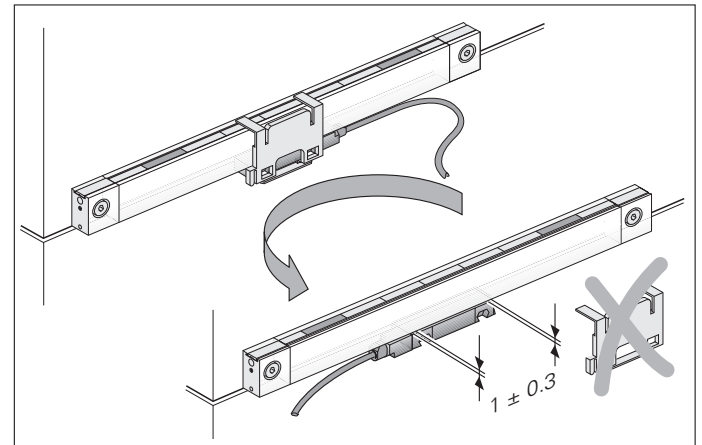
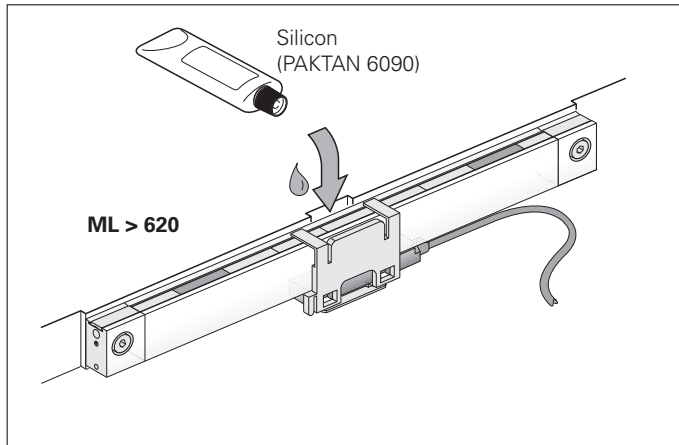
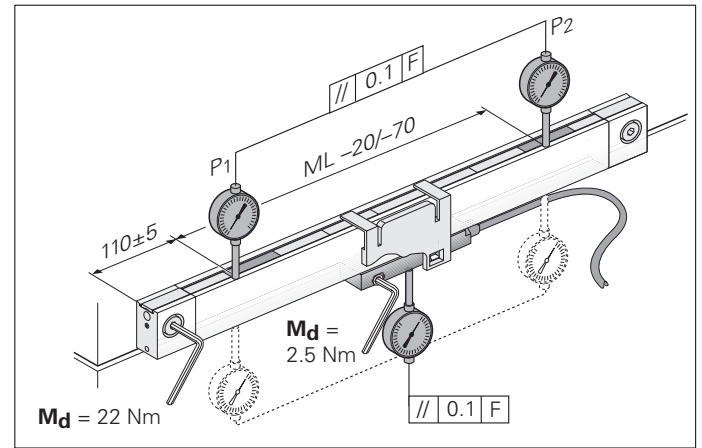
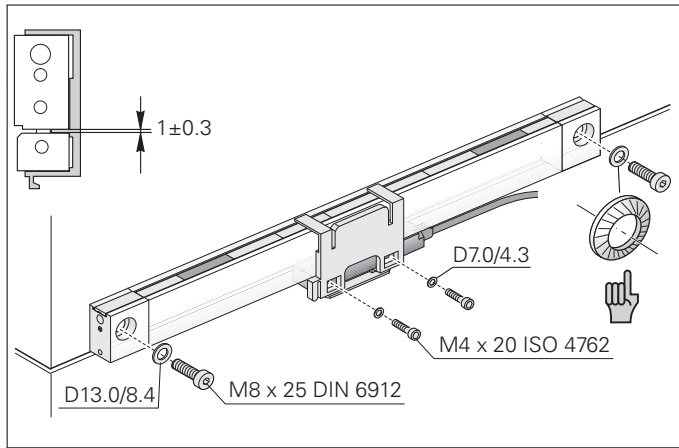

Anbau mit Montageschiene · *Mounting with Mounting Spar* · Montage avec rail de guidage

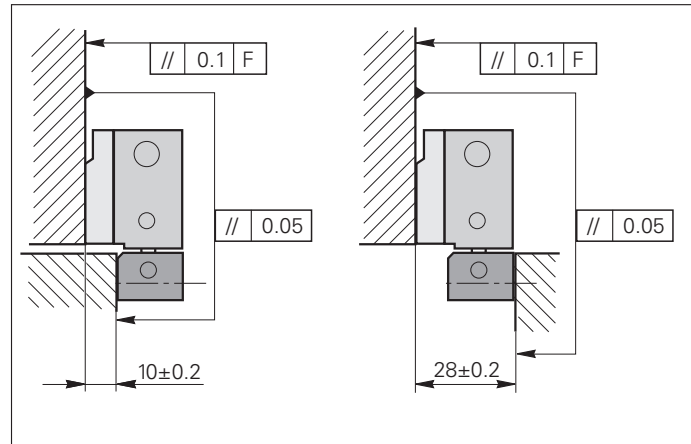
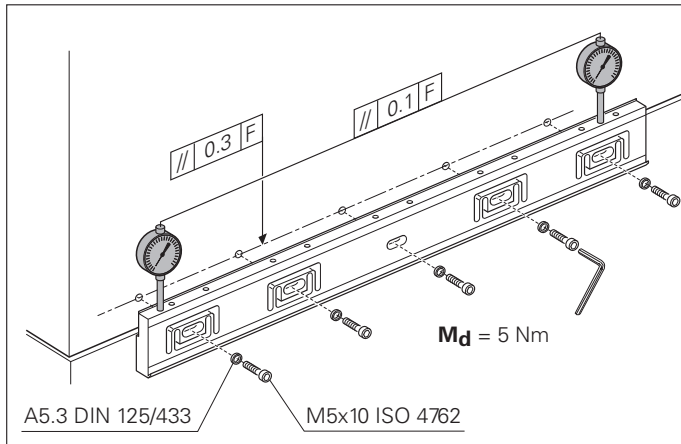
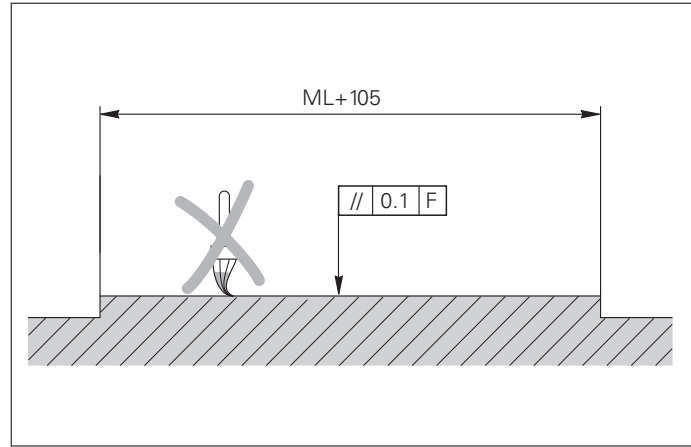
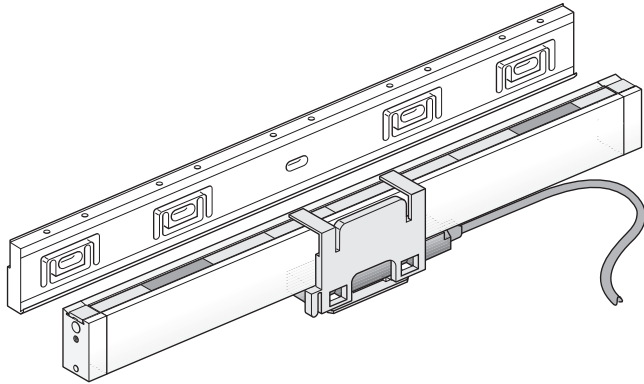

Montaggio con guida · Instalación con guía de montaje

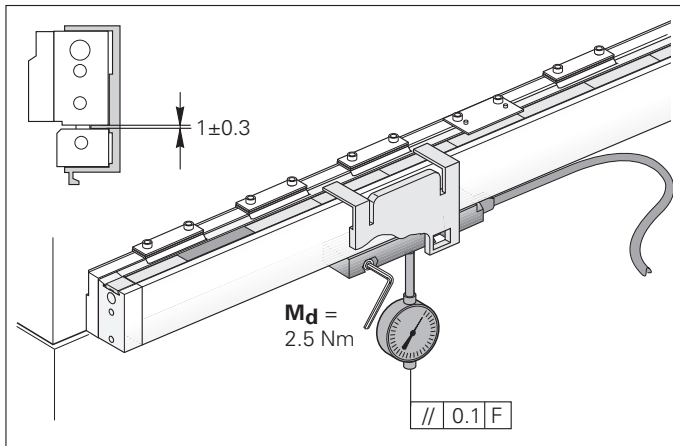
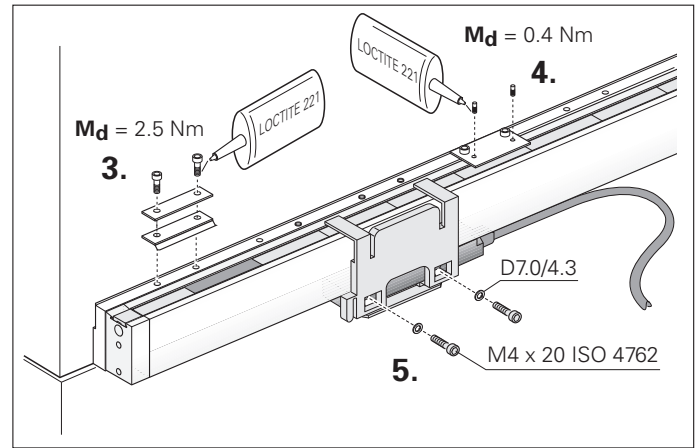
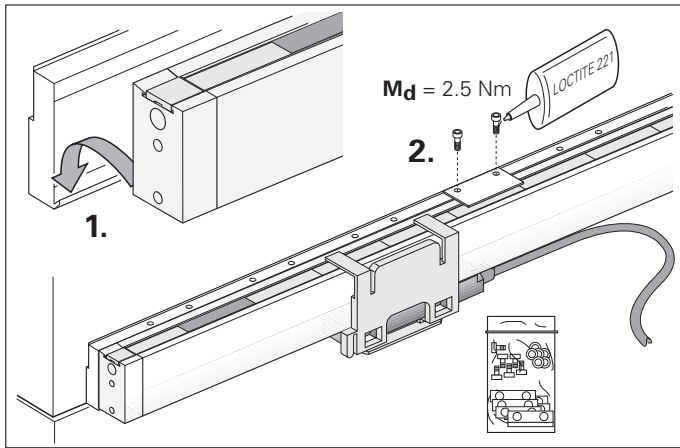

Abschließende Arbeiten · Final Steps · Opérations finales · Operazioni finali · Trabajos finales

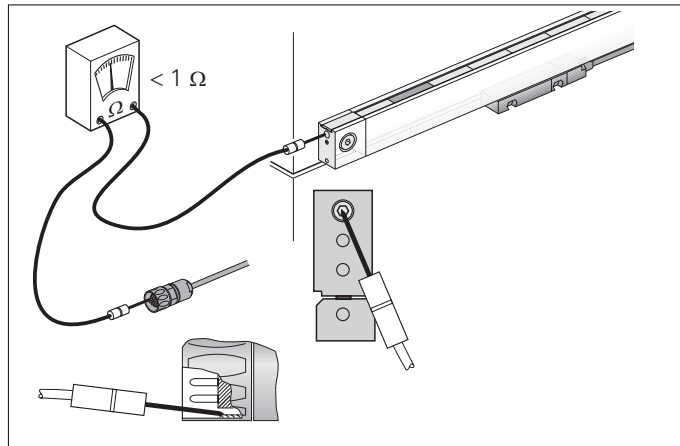
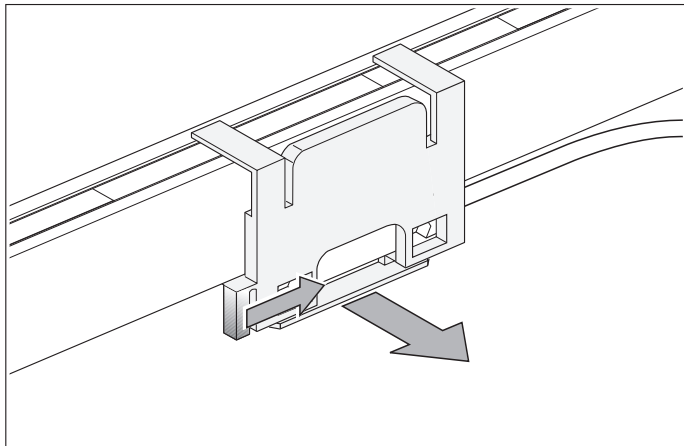

Bei Erdungsproblemen zusätzlich Endstück oder Montageschiene erden!

If grounding problems occur, ground also the end piece or mounting spar!

En cas de problèmes de mise à terre, mettre aussi l'embout ou le rail de montage à la terre!



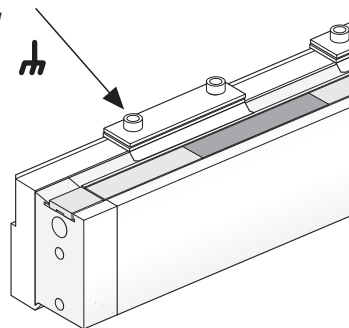
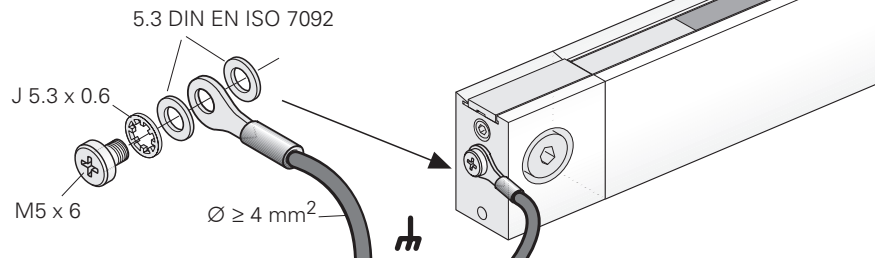

Nel caso di problemi di messa a terra, mettere a terra anche il blocchetto terminale o la guida di montaggio!

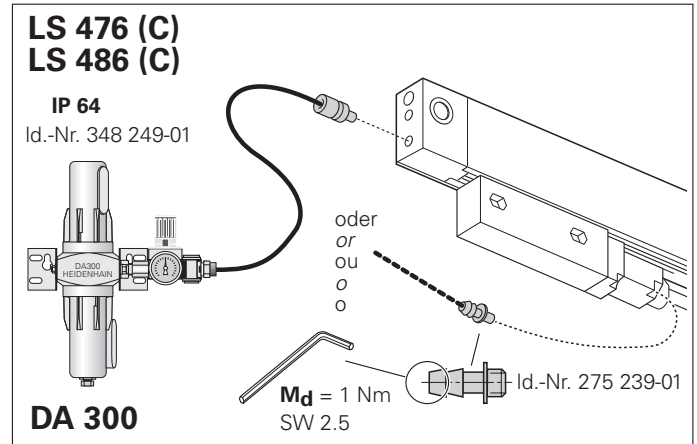
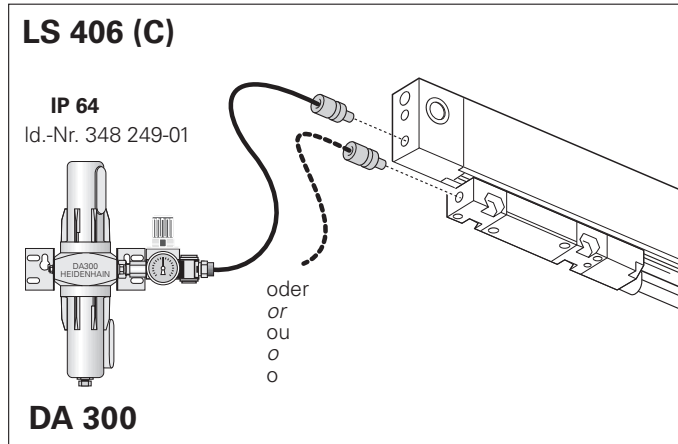
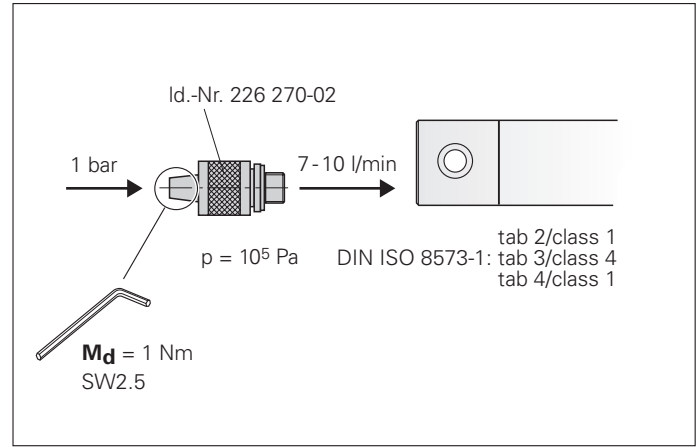
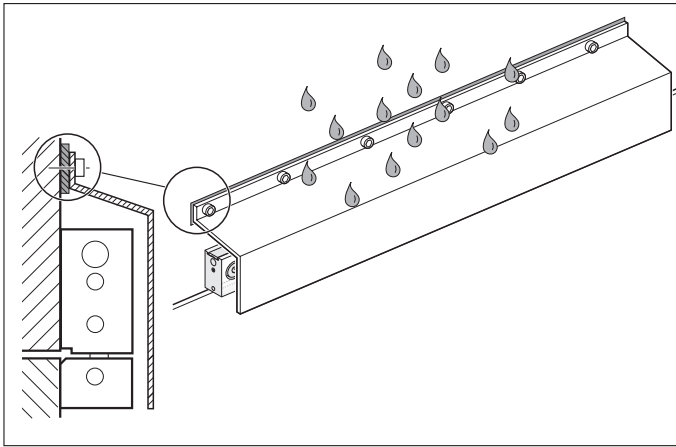
¡En caso de problemas de tierras, poner a tierra adicionalmente la pieza final o la guía de montaje!



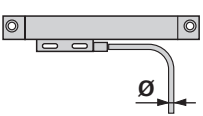

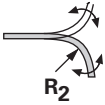
Technische Kennwerte · Specifications · Caractéristiques techniques · Dati tecnici · Datos técnicos

		
Ø 6 mm	$R_1 \geq 20 \text{ mm}$	$R_2 \geq 75 \text{ mm}$
Ø 10 mm	$R_1 \geq 35 \text{ mm}$	$R_2 \geq 75 \text{ mm}$
 Ø 8 mm	$R_1 \geq 40 \text{ mm}$	$R_2 \geq 100 \text{ mm}$

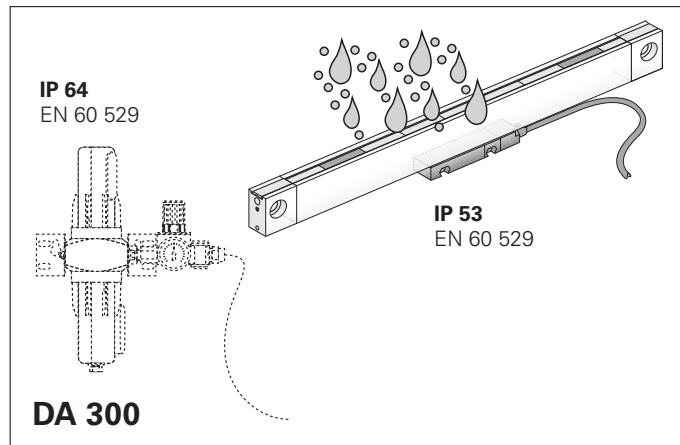
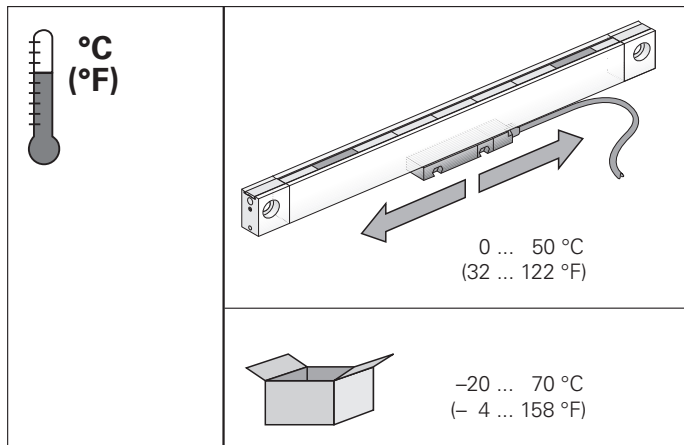
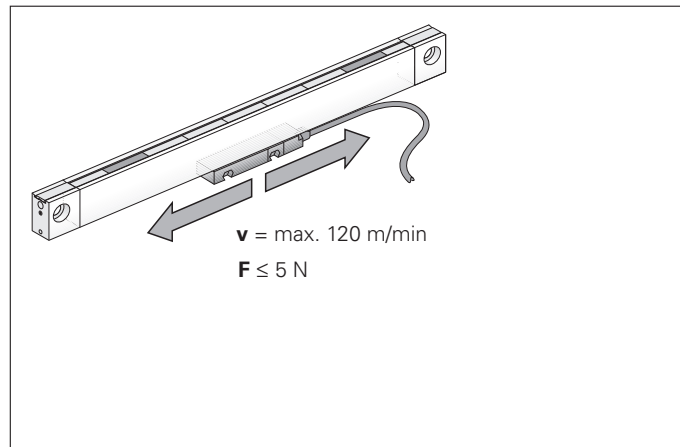

Vibration/Schock · Vibration/Shock · Vibrations/Chocs · Vibrazioni/Shock · Vibración/Choque

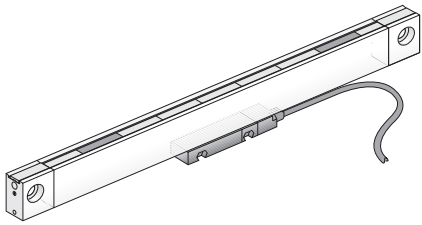

EN 60 068-2-6 (55 ... 2000 Hz): max. 100 m/s²
 EN 60 068-2-27 (11 ms): max. 300 m/s²

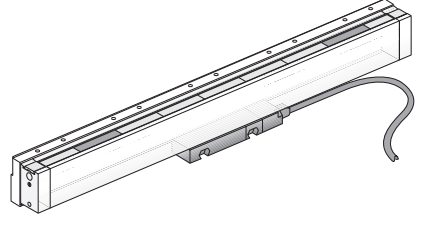

EN 60 068-2-6 (55 ... 2000 Hz): max. 200 m/s²
 EN 60 068-2-27 (11 ms): max. 300 m/s²

Elektrische Kennwerte · Electrical Data · Caractéristiques électriques · Dati elettrici · Datos eléctricos

LS 406 (C)

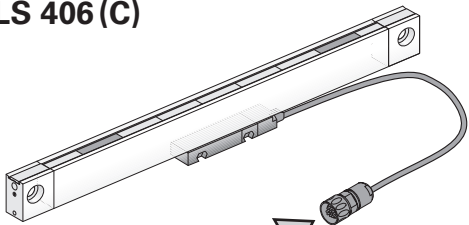

U_p = 5 V ± 5 %
 (max. 70 mA)

I₁: 7 ... 16 μAss
I₂: 7 ... 16 μAss
I₀: 2 ... 8 μA

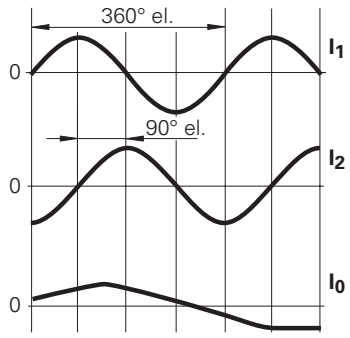

EN 50 178/4.98; 5.2.9.5
 IEC 364-4-41: 1992; 411(PELV/SELV)
 (siehe, see, voir, vedi, véase
 HEIDENHAIN D231 929)

LS 476 (C)

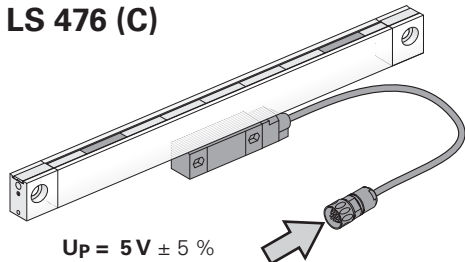

$U_P = 5\text{ V} \pm 5\%$
(max. 140 mA)



EN 50 178/4.98; 5.2.9.5
IEC 364-4-41: 1992; 411(PELV/SELV)

(siehe, see, voir, vedi, véase
HEIDENHAIN D 231 929)

U_{a1}, U_{a2}, U_{a0}
 $\overline{U_{a1}}, \overline{U_{a2}}, \overline{U_{a0}}, \overline{U_{aS}}$

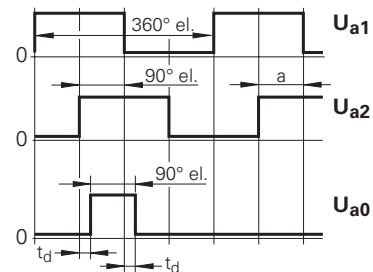
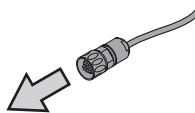

$|t_d| \leq 0.1\ \mu\text{s}$

$a \geq 0.5\ \mu\text{s}$

LS 486 (C)

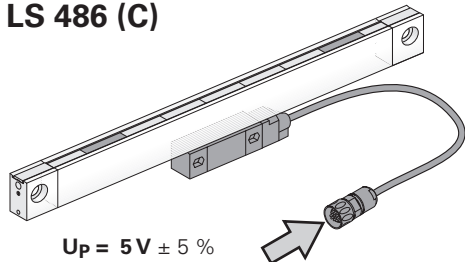

$U_P = 5\text{ V} \pm 5\%$
(max. 150 mA)



EN 50 178/4.98; 5.2.9.5
IEC 364-4-41: 1992; 411(PELV/SELV)

(siehe, see, voir, vedi, véase
HEIDENHAIN D 231 929)

A: 0.6 ... 1.2 V_{SS}
B: 0.6 ... 1.2 V_{SS}
R: 0.2 ... 0.85 V

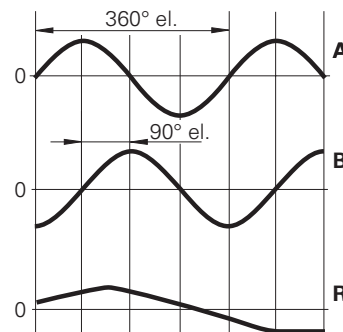
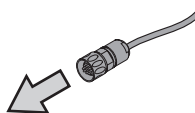

LS 476 (C)

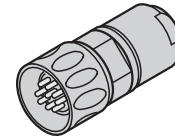
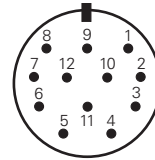
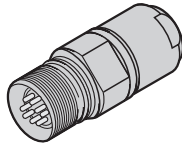
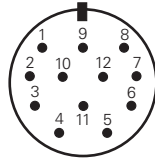

Schirm auf Gehäuse
Shield on housing
blindage sur boîtier
schermo sulla carcassa
blindaje a carcasa

5	6	8	1	3	4	12	10	2	11	7	/
U_{a1}	$\overline{U_{a1}}$	U_{a2}	$\overline{U_{a2}}$	U_{a0}	$\overline{U_{a0}}$	5V U_p	0V U_N	5V sensor	0V sensor	$\overline{U_{aS}}$	/
braun <i>brown</i> brun <i>marrone</i> marrón	grün <i>green</i> vert <i>verde</i> verde	grau <i>gray</i> gris <i>grigio</i> gris	rosa <i>pink</i> rose <i>rosa</i> rosa	rot <i>red</i> rouge <i>rosso</i> rojo	schwarz <i>black</i> noir <i>nero</i> negro	braun/grün <i>brown/green</i> brun/vert <i>marrone/verde</i> marron/verde	weiß/grün <i>white/green</i> blanc/vert <i>bianco/verde</i> blanco/verde	blau <i>blue</i> bleu <i>azzurro</i> azul	weiß <i>white</i> blanc <i>bianco</i> blanco	violett <i>violet</i> violet <i>viola</i> violeta	gelb <i>yellow</i> jaune <i>giallo</i> amarillo

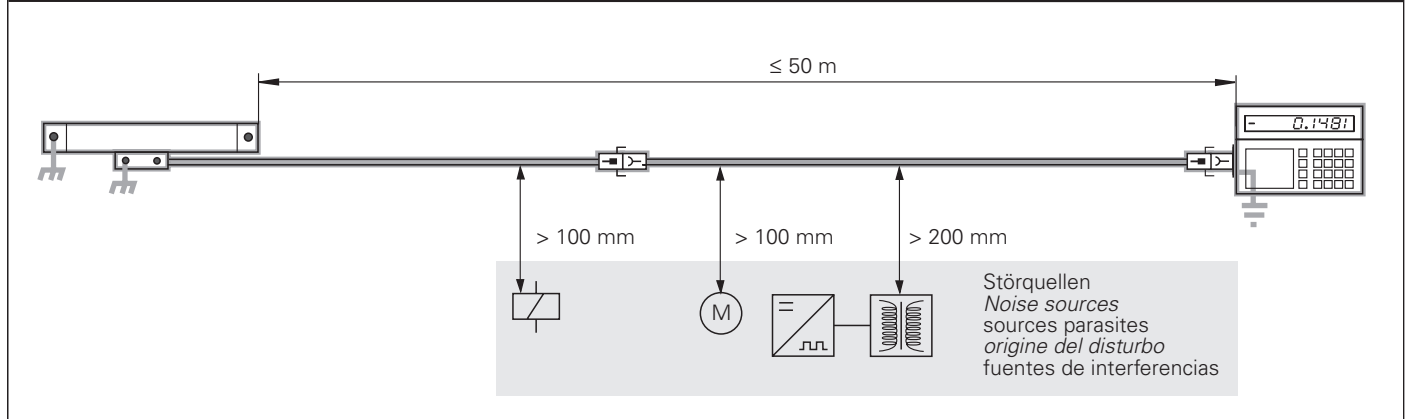

LS 406 (C)

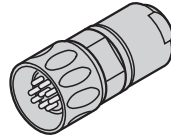
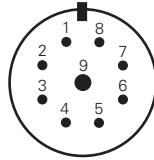
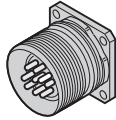
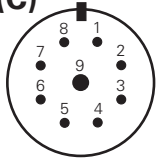

1) Außenschirm auf Gehäuse
External shield on housing
 blindage externe sur boîtier
schermo esterno sulla carcassa
 blindaje externo a carcasa

2) Innenschirm Pin 9
Internal shield pin 9
 blindage interne pin 9
schermo interno pin 9
 blindaje interno pin 9

1	2	5	6	7	8	3	4	1)	9	
I_1		I_2		I_0		5 V U_P	0 V U_N		2)	weiß/braun <i>white/brown</i> blanc/brun <i>blanc/marrone</i> blanco/marrón
+	-	+	-	+	-					
grün <i>green</i> vert <i>verde</i> verde	gelb <i>yellow</i> jaune <i>giallo</i> amarillo	blau <i>blue</i> bleu <i>azzurro</i> azul	rot <i>red</i> rouge <i>rosso</i> rojo	grau <i>gray</i> gris <i>grigio</i> gris	rosa <i>pink</i> rose <i>rosa</i> rosa	braun <i>brown</i> brun <i>marrone</i> marrón	weiß <i>white</i> blanc <i>bianco</i> blanco			

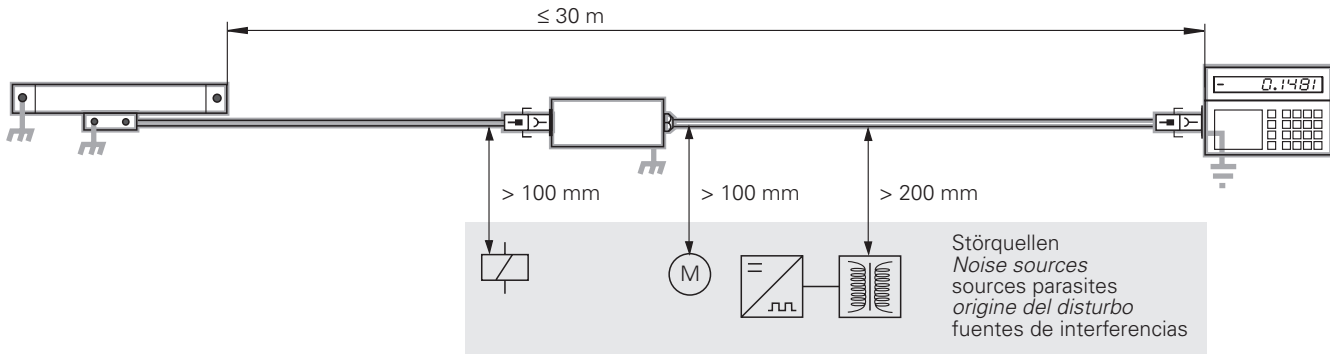

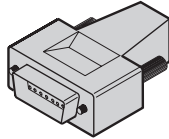
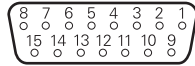

1) Außenschirm auf Gehäuse
External shield on housing
 blindage externe sur boîtier
schermo esterno sulla carcassa
 blindaje externo a carcasa

2) Innenschirm Pin 13
Internal shield pin 13
 blindage interne pin 13
schermo interno pin 13
 blindaje interno pin 13

3	4	6	7	10	12	1	2	1)	13
I ₁		I ₂		I ₀		5V U _P	0V U _N		2)
+	-	+	-	+	-				
grün <i>green</i> vert verde verde	gelb <i>yellow</i> jaune giallo amarillo	blau <i>blue</i> bleu azzurro azul	rot <i>red</i> rouge rosso rojo	grau <i>gray</i> gris grigio gris	rosa <i>pink</i> rose rosa rosa	braun <i>brown</i> brun marrone marrón	weiß <i>white</i> blanc bianco blanco		weiß/braun <i>white/brown</i> blanc/brun bianco/marrone blanco/marrón



LS 486 (C)

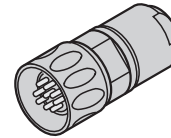
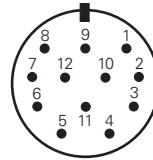
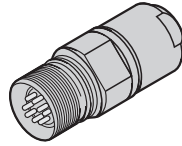
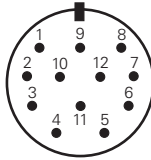

Schirm auf Gehäuse
Shield on housing
blindage sur boîtier
schermo sulla carcassa
blindaje a carcasa

5	6	8	1	3	4	12	10	2	11	7	/
A		B		R		5V U _P	0V U _N	5V sensor	0V sensor	/	/
+	-	+	-	+	-						
braun <i>brown</i> brun <i>marrone</i> marrón	grün <i>green</i> vert <i>verde</i> verde	grau <i>gray</i> gris <i>grigio</i> gris	rosa <i>pink</i> rose <i>rosa</i> rosa	rot <i>red</i> rouge <i>rosso</i> rojo	schwarz <i>black</i> noir <i>nero</i> negro	braun/grün <i>brown/green</i> brun/vert <i>marrone/verde</i> marron/verde	weiß/grün <i>white/green</i> blanc/vert <i>bianco/verde</i> blanco/verde	blau <i>blue</i> bleu <i>azzurro</i> azul	weiß <i>white</i> blanc <i>bianco</i> blanco	violett <i>violet</i> violet <i>viola</i> violeta	gelb <i>yellow</i> jaune <i>giallo</i> amarillo

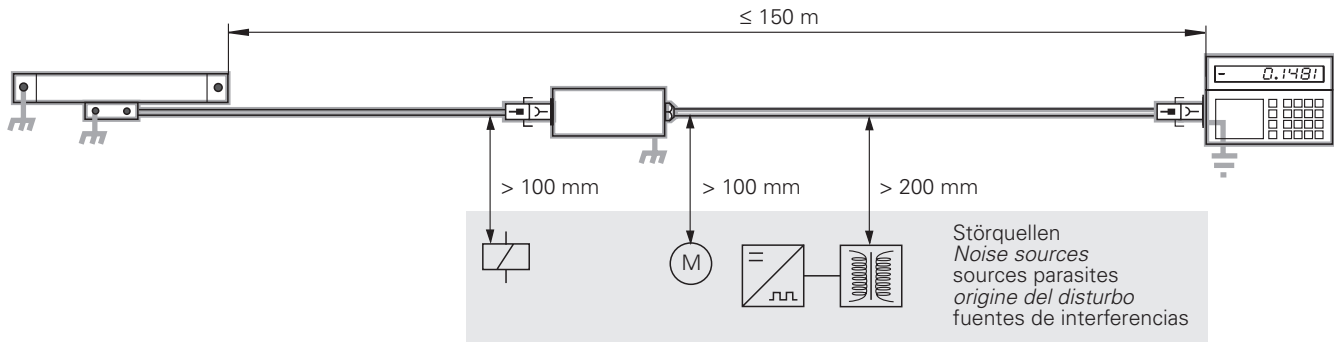

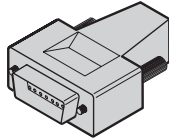
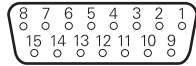

Schirm auf Gehäuse
Shield on housing
 blindage sur boîtier
schermo sulla carcassa
 blindaje a carcasa

3	4	6	7	10	12	1	2	9	11	14	/
A		B		R		5V U _P	0V U _N	5V sensor	0V sensor	/	/
+	-	+	-	+	-						
braun <i>brown</i> brun <i>marrone</i> marrón	grün <i>green</i> vert <i>verde</i> verde	grau <i>gray</i> gris <i>grigio</i> gris	rosa <i>pink</i> rose <i>rosa</i> rosa	rot <i>red</i> rouge <i>rosso</i> rojo	schwarz <i>black</i> noir <i>nero</i> negro	braun/grün <i>brown/green</i> brun/vert <i>marrone/verde</i> marron/verde	weiß/grün <i>white/green</i> blanc/vert <i>bianco/verde</i> blanco/verde	blau <i>blue</i> bleu <i>azzurro</i> azul	weiß <i>white</i> blanc <i>bianco</i> blanco	violett <i>violet</i> violet <i>viola</i> violeta	gelb <i>yellow</i> jaune <i>giallo</i> amarillo



HEIDENHAIN

DR. JOHANNES HEIDENHAIN GmbH

Dr.-Johannes-Heidenhain-Straße 5

83301 Traunreut, Germany

☎ +49 (86 69) 31-0

FAX +49 (86 69) 50 61

E-Mail: info@heidenhain.de

Technical support FAX +49 (86 69) 31-10 00

Measuring systems ☎ +49 (86 69) 31-31 04

E-Mail: service.ms-support@heidenhain.de

TNC support ☎ +49 (86 69) 31-31 01

E-Mail: service.nc-support@heidenhain.de

NC programming ☎ +49 (86 69) 31-31 03

E-Mail: service.nc-pgm@heidenhain.de

PLC programming ☎ +49 (86 69) 31-31 02

E-Mail: service.plc@heidenhain.de

Lathe controls ☎ +49 (7 11) 95 28 03-0

E-Mail: service.hsf@heidenhain.de

www.heidenhain.de



Ve 04

312 619-94 · 100 · 4/2006 · E · Printed in Germany

Änderungen vorbehalten · *Subject to change without notice* · Sous réserve de modifications · *Con riserva di modifiche* · Sujeto a modificaciones

