

## Fiber Optic Analog: SA1C-FK

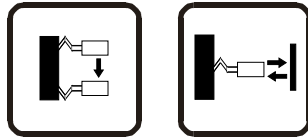

### Key features:

- High-speed, miniature photoelectric sensors with analog (4 - 20mA) and digital output
- Senses gradual color changes
- Available in red or green LEDs
- Through-beam and reflected-light sensing available
- Ideal for either color mark applications or simple presence and absence applications requiring analog output
- Compact size allows for DIN rail mounting
- Fiber optic units available to address specific application needs
- Simple to install
- IP66 protection rating

Built on the foundation of SA1C-F, SA1C-FK is ideal for either color mark applications or simple presence and absence applications requiring analog output.

Featuring analog and digital output, this sensor comes in through-beam or reflected-light sensing styles.

### Part Numbers

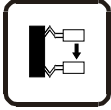
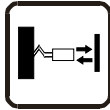
Function	Light Source Element	Output	Part Number
 	Red LED	Analog output + NPN output	SA1C-FK3
	Green LED		SA1C-FK3G

For information on accessories, see page 203.



Function is determined by the fiber optic unit used.

## Specifications

		SA1C-FK3	SA1C-FK3G
Light Source Element	Red LED	√	—
	Green LED	—	√
Sensing Distance	Depends on the fiber unit (see page 204)	√	√
Power Voltage	12 to 24V DC (Operating voltage: 10 to 30V DC) ripple 10% maximum	√	√
Current Draw	80mA maximum	√	√
Analog Current Output	4 to 20mA, 5V DC maximum <sup>1</sup>	√	√
Digital Output	NPN open collector 30V DC, 100mA maximum, 1.5V maximum with short circuit protection	√	√
Operation Mode	Dark ON (connect MODE line to GND line)	√	√
	Light ON (connect MODE line to power line)	√	√
Response	0.5ms maximum <sup>2</sup>	√	√
Indicator	Operation LED: Red, Stable LED: Green	√	√
Detectable Object	Translucent object, opaque object	√	√
Hysteresis	20% maximum (using reflex fiber unit)	√	√
Sensitivity	4-turn adjustment	√	√
Operation Point Control	1 turn	√	√
Receiver Element	Photo diode	√	√
Operating Temperature	−25 to +55°C (performance will be adversely affected if the sensor becomes coated with ice)	√	√
Storage Temperature	−30 to +70°C (performance will be adversely affected if the sensor becomes coated with ice)	√	√
Operating Humidity	35 to 85% RH (avoid condensation)	√	√
Extraneous Light Immunity	Sunlight: 10,000 lux maximum; Incandescent light: 3,000 lux (at the receiver)	√	√
Noise Resistance	Normal mode: 500V (50ns to 1μs, 100Hz: Using a noise simulator)	√	√
	Common mode: 300V (50ns to 1μs, 100Hz: Using a noise simulator)	√	√
Insulation Resistance	Between live and dead parts: 20MΩ minimum, with 500V DC megger	√	√
Dielectric Strength	Between live and dead parts: 1,000V, 1 minute	√	√
Vibration Resistance	Damage limits: 10 to 55Hz; Single amplitude: 0.75mm 20 cycles in each of 3 axes	√	√
Shock Resistance	Damage limits: 500 m/sec <sup>2</sup> 10 cycles in each of 3 axes	√	√
Degree of Protection	IP66—IEC Pub 529	√	√
Cable	Ø4.4mm 5-core vinyl cabtyre cable 0.2mm <sup>2</sup> , 6'–6-3/4" (2m) long	√	√
Material	Housing: PBT	√	√
Accessories	Mounting bracket, adjusting screwdriver, load resistor (249Ω) for converting analog amperage to voltage (1 to 5V)	√	√
Interference Prevention	Up to 2 units can be installed in close proximity. For analog output, interference prevention is not possible.	√	√
Weight	Approximately 75g	√	√



- Analog current output specification is based on the power voltage range from 12 to 24V DC (±10%). Use the attached resistor (249Ω, 1/4W) as a load resistance for converting analog output to voltage.
- Response time for analog current output is between 10% and 90% of the rise or fall of the voltage signal when using a 249Ω resistor.

## Dimensions (mm)

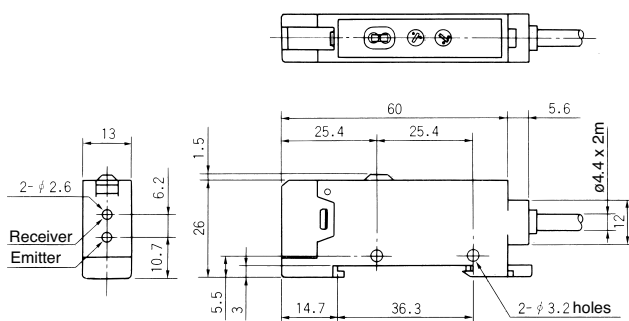
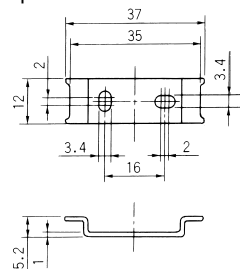
Panel Mounting Bracket (attachment)  
Not required for DIN Rail mounting

## Mounting Hole Layout

