

Power Supplies, Backplanes / Test Adapters and Microcomputer Packaging Systems

Schroff[®]

Last update: 02/2003

3

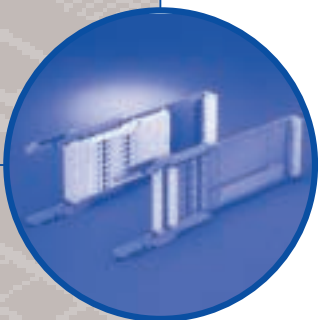



19" compatible power supplies overview

Power supply units..... 3.10.0

19" compatible.....3.11.0

Open frame.....3.12.0

Power systems.....3.13.0

Uninterruptable power supplies (UPS)3.14.0

Backplanes/ test adapters .. 3.20.0

Microcomputer packaging systems (MPS) 3.30.0

Appendix..... 3.90.0



113-00-004

Application

19" compatible power supplies are used to supply controls and systems with the required direct voltage. They are pluggable power supplies with a compact design and high efficiency.

3.3, 5, 12, 15, 24, 48 and 60 volts are available as standard output voltages.

Other output voltages available on request.

Electrical design

The inputs and outputs are on the rear side using standardized male connectors to DIN 41612.

A primary fuse is mounted in the power supplies.

Operation is displayed at the front with LEDs.

Mechanical design

Power supplies are 3 or 6 units (U) and a printed board depth of 160 mm.

Depending on the output power, the power supplies have a width of 6 to 28 units (HP).

Heat dissipation

Power supply heat dissipation is achieved without fans, and is possible up to an ambient temperature of 70°C. Output derating is from 40°C to 50°C.

Standards/approvals

The power supplies are CE-certified and UL- and VDE/LGA-approved. Approval to EN 60950 applies to AC mains operation.

The exterior dimensions of the systems correspond to the 19" standard DIN 41494, Part 1 and the mounting dimensions for the plug-in units to DIN 41494 Part 5.

19" compatible power supplies overview

AC/DC-switched mode power supplies

ecopower - cost-optimized
maxpower - high performance
maxpowerPRO - extremely high performance,
 Compact PCI

- 1 ... 4 output voltages
- 50 to 350 W



11399014

AC/DC linear control systems

High control accuracy
 and low residual ripple

- 1 ... 3 output voltages
- 8 to 58 W



11300001

AC/DC non-regulated, screened

power supply with basic specification
 made on the output voltage

- 24 V output voltage
- 84 and 240 W



11300001

DC/DC converters

Controlled direct voltage converter

- 1 ... 4 output voltages
- 20 to 350 W

maxpowerPRO - extremely high performance,
 Compact PCI

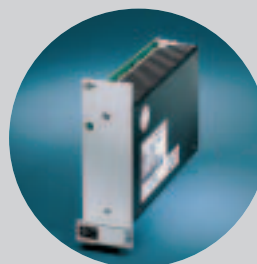

11396005

Accessories for 19"-compatible power supplies

- Connector H 15 F
- Keying/coding
- EMC contact strips
- Wall/horizontal rail installation

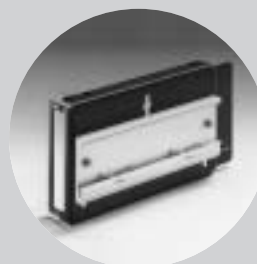

11395007

AC/DC switched mode power supplies

- Single, 50 W3.11.2
- Single, 80 W3.11.4
- Single, 100 W3.11.6
- Single, 130 W3.11.8
- Dual, 80 W3.11.10
- Dual, 100 W3.11.12
- Triple, 80 W3.11.14
- Triple, 100 W3.11.16
- Triple, 130 W3.11.18
- Triple,
150 / 224 W3.11.20
- Quad, 250 W3.11.22
- Quad, 350 W3.11.24

AC/DC linear control systems

- Single, 8 - 60 W ..3.11.26
- Dual, 10 - 58 W...3.11.28
- Triple, 7 - 39 W...3.11.30

AC/DC non-regulated

- Single, 84 W3.11.32
- Single, 240 W3.11.34

DC/DC converters

- Single,
20 to 120 W3.11.36
- Dual, 55 to 72 W..3.11.38
- Triple,
64 to 70 W3.11.40
- Quad, 250 W3.11.42
- Quad, 350 W3.11.44

Accessories

- Mating connector
female connector
H 15 F3.11.46
- Keying/coding3.11.47
- Guide rails3.11.47
- Z-rails3.11.47
- EMC
contact strips3.11.48
- Wall/horizontal rail
installation3.11.49



19" compatible AC/DC switched mode

Power supply units..... 3.10.0
19" compatible.....3.11.0
 Open frame.....3.12.0
 Power systems.....3.13.0
 Uninterruptable power supplies (UPS)3.14.0

Backplanes/
test adapters .. 3.20.0

Microcomputer packaging systems (MPS) 3.30.0

Appendix..... 3.90.0

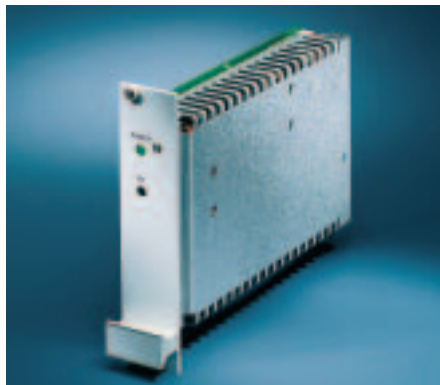

11396002

Single, 50 W

ecopower

- 19" compatible AC/DC switched mode power supplies, pluggable 3 U x 160 mm deep
- Wide range mains input voltage range (wide range from 90 – 264 V_{AC} and 130 – 340 V_{DC})
- 1 output voltage
- Redundancy operation with integrated decoupling diode
- Even current share in the event of parallel operation via current share bus (CSB)
- Signalling: Output voltage OK
- For industrial and telecommunications applications
- High reliability and long life
- Cost-optimized

ERG
EN 60950



100 x 160 mm

171.93

2.5

32

DJM0084

PSA46292

Pin	Connection
4	Output + V ₁
6	
8	
8	Sense + V ₁
10	Sense 0V V ₁
12	Output 0V V ₁
14	
16	
18	–
20	–
22	CSB
24	Output OK
26	–
28	L
30	N
32	PE ⊕

Note

The front panel is not included in delivery.

Voltage in V	Output data with T _U = 0 ... 50 °C			Height in U	Width A in HP	Power supply Type	Order No. ¹⁾	
	Current in A	Power output in W	Mains voltage 90 – 264 V _{AC}				Front panel ²⁾ EMC	
5	9.0	45	3	6	SEK 105	13100-043	21006-943	
12	4,2	51			SEK 112	13100-044		
15	3,4				SEK 115	13100-041		
24	2,1				SEK 124	13100-045		
48	1,1				53	SEK 148		13100-046

¹⁾ Please order front panel separately

²⁾ Front anodised, rear side chromated, slotted on both sides for mounting EMC contact strips in the event of increased EMC requirements
(3 U EMC contact strips, 10 units, Order No. 21101-705)

Mating connector H15F with FASTON connection, Order No. 69001-733

19" compatible AC/DC switched mode



Technical data

Input parameters						
Mains voltage	Nominal values V_{AC}	100 – 240 V_{AC}				
	Operating-ranges	90 – 264 V_{AC} 128 – 370 V_{DC}				
Mains nominal current at 90 V_{AC} /187 V_{AC}		1.3/0.6 A				
Mains frequency range		Type 48 – 62 Hz				
Mains input current in accordance with		EN 61000-3-2 + A14				
Efficiency		Type 69 – 80 %				
Switch-on current I_p (with 230 V_{AC})		< 20 A				
Discharge current		\leq 500 μ A				
Output parameters						
Output power [W]		45	51			53
Output voltage ΔV [V]	factory set	5	12	15	24	48
	Adjustment range	4.2–6	11–13.5	13.5–16.5	21–25.5	43–50
Output current (with 90 – 264 V_{AC}) [A]	0 ... 50°C	9.0	4.2	3.4	2.1	1.1
	70°C	6.0	2.9	2.4	1.5	0.8
Short-circuit current [A]		< 11	< 6	< 4.5	< 3	< 2
Over-voltage protection OVP (shuts power supply off), automatically resets [V]		6 \pm 0.3	14 \pm 0.5	17 \pm 0.5	27 \pm 1	52 \pm 2
Residual ripple with [mV _{PP}]	100 Hz	20	< 100	< 100	< 100	< 150
	Clock frequency (100 kHz)	< 40	< 50	< 50	< 50	< 60
Interference voltage (BW: 100 MHz) [mV _{PP}]		< 100	< 200	< 200	< 200	< 200
Load control, static (load change 0 – 100 %) [mV]		< 50	< 50	< 50	< 100	< 100
Mains control 90 – 264 V [mV]		< 10	< 25	< 25	< 100	< 100
Temperature coefficient		-0.015 %/K				
CSB and output decoupled via diode		Mounted				
Dynamic control deviations (load change: 50 ... 100 % with 100 Hz; $di/dt = 0,135$ A/ μ s)						
Control time at $0.01 \times V_1$ Nominal		< 1.5 ms				
Overshoot and under-shoot amplitude [mV]		< 500	< 250	< 300	< 500	

Protection and monitoring facilities		
Switch-on time		< 0.8 s
Mains fuse, high breaking sluggish		4 A/250 V_{AC} , 5 \times 20 mm, DIN EN 60127-2/V
Power failure bridging at $V_{AC} = 187$ V_{AC} and 100 % load		> 30 ms
Remote sense compensated		Max. 0.5 V
Characteristic current-limiting curve		U/I
"Output voltage ok" signalling		Output OK, open collector signal, low active, max. 55 V/50 mA
Test and environmental conditions		
Climatic test to		IEC 68-2-38
Shock and vibration test in accordance with acceleration of 2 g		EN 60068-2-6
Height 3 U/ depth 160 mm		Width 6 HP
Weight (mass)		0.55 kg
CE	Interference emission	EN 50081-1, EN 55011 Class B, EN 55022 Class B
	Interference immunity, degree of severity 3	EN 50082-2, EN 61000-4-2, EN 61000-4-3, EN 61000-4-4, EN 61000-4-5, EN 61000-4-6
	Safety, class of protection 1	EN 60950 (ERG)
High voltage test to EN 60950	Input-output	4.3 kV _{DC}
	Input PE	2.2 kV _{DC}
	Output PE	0.7 kV _{DC}
UL 1950		No. E 153809
Power supply maintenance-free		Yes
Cooling		Convection
Operation/storage ambient temperature		0 ... 70°C / -20 ... +85°C
MTBF at full load, $T_U = 40^\circ\text{C}$		500,000 h

AC/DC switched mode power supplies

Single, 50 W	3.11.2
Single, 80 W	3.11.4
Single, 100 W	3.11.6
Single, 130 W	3.11.8
Dual, 80 W	3.11.10
Dual, 100 W	3.11.12
Triple, 80 W	3.11.14
Triple, 100 W	3.11.16
Triple, 130 W	3.11.18
Triple, 150 / 224 W	3.11.20
Quad, 250 W	3.11.22
Quad, 350 W	3.11.24

AC/DC linear control systems

Single, 8 – 60 W ..	3.11.26
Dual, 10 – 58 W ...	3.11.28
Triple, 7 – 39 W ...	3.11.30

AC/DC non-regulated

Single, 84 W	3.11.32
Single, 240 W	3.11.34

DC/DC converters

Single, 20 to 120 W	3.11.36
Dual, 55 to 72 W ..	3.11.38
Triple, 64 to 70 W	3.11.40
Quad, 250 W	3.11.42
Quad, 350 W	3.11.44

Accessories

Mating connector female connector H 15 F	3.11.46
Keying/coding	3.11.47
Guide rails	3.11.47
Z-rails	3.11.47
EMC contact strips	3.11.48
Wall/horizontal rail installation	3.11.49

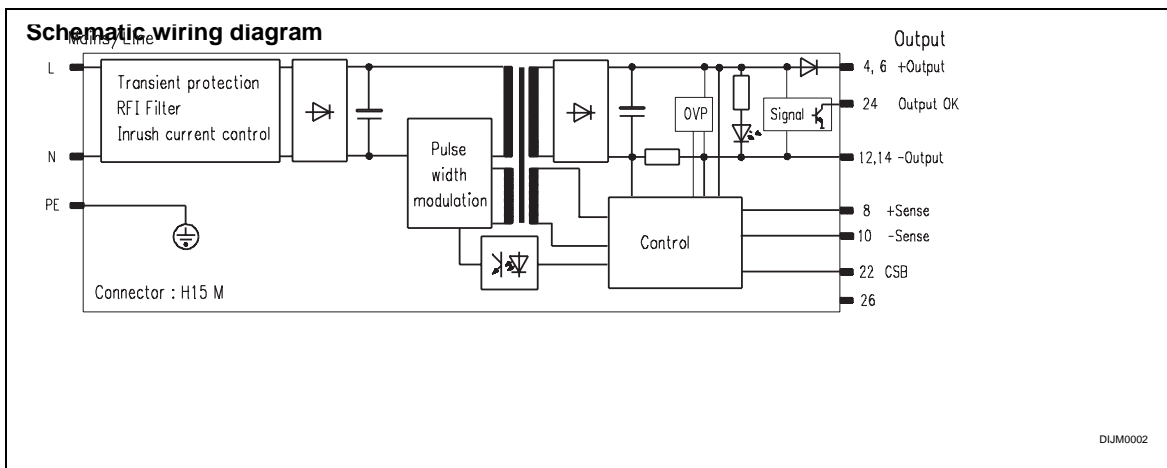



19" compatible AC/DC switched mode

Power supply units..... 3.10.0

19" compatible.....3.11.0

Open frame.....3.12.0

Power systems.....3.13.0

Uninterruptable power supplies (UPS)3.14.0

Backplanes/ test adapters .. 3.20.0

Microcomputer packaging systems (MPS) 3.30.0

Appendix..... 3.90.0



11399005



Single, 80 W

ecopower

- 19" compatible AC/DC switched mode power supplies, pluggable 3 U
- Wide range mains input voltage range (90 – 254 V_{AC} and 100 – 360 V_{DC})
- Power factor correction (PFC) to EN 61000-3-2
- 1 output voltage
- Redundancy operation with integrated decoupling diode
- Even current share in the event of parallel operation via current share bus (CSB)
- Signalling: Output voltage OK
- For industrial and telecommunications applications
- International approvals EN 60950, UL
- High reliability and long life
- Cost-optimized

Pin	Connection
4	Output + V ₁
6	
8	Sense + V ₁
10	Sense 0V V ₁
12	
14	Output 0V V ₁
16	
18	-
20	
22	CSB
24	Output OK
26	-
28	L
30	N
32	PE ⊕

Note

The front panel is not included in delivery.

Output data at T _U = 0 ... 50 °C					Order No. ¹⁾		
Voltage in V	Current (with 190 V) in A	Power output in W	Height in U	Width A in HP	Power supply Type	Mains voltage 90 – 254 V _{AC}	Front panel ²⁾ EMC
3,3	14,0	46	3	6	SEM 103	13100-054	21006-943
5	14,0	70			SEM 105	13100-055	
12	6,5	78			SEM 112	13100-056	
15	5,2				SEM 115	13100-057	
24	3,4	82			SEM 124	13100-058	

¹⁾ Please order front panel separately

²⁾ Front anodised, rear side chromated, slotted on both sides for mounting EMC contact strips in the event of increased EMC requirements
(3 U EMC contact strips, Order No. 21101-705, 10 pieces)

Mating connector H15F with FASTON connection, Order No. 69001-733

19" compatible AC/DC switched mode



Technical data

Input parameters						
Mains-voltage	Nominal values V_{AC}	100 – 240 V_{AC}				
	Operating-ranges	90 – 254 V_{AC} 100 – 360 V_{DC}				
Mains nominal current at 90 V_{AC}	1.4 A					
Mains frequency range	50 – 60 Hz					
Power Factor Correction in accordance with	EN 61000-3-2					
Efficiency type	58 %	64 %	75 %	77 %		
Switch-on current I_p (with 230 V_{AC})	< 15 A					
Output parameters at		190/90 V_{AC}				
Output power max. (50 °C) [W]	46/38	70/58	78/66		82/67	
Output voltage [V]	factory set	3.3	5	12	15	24
	Adjustment range ΔV	2.7–3.5	5–5.5	11.5–15.7		21.8–25.3
Output current [A]	0 ... 50 °C	14/11.5	14/11.5	6.5/5.5	5.2/4.4	3.4/2.8
	70 °C	10.5/9	10.5/9	4.7/4.3	3.8/3.4	2.6/2.2
Current limitation shuts the output off after approx. 20 ms, automatically resets after approx. 2 s, shuts power supply off following longer overload	Permanently short-circuit resistant					
Residual ripple/ Interference voltage (BW: 30 MHz) [mV _{PP}]	< 80			< 150		
Mains and load control, static (load change 0 – 100 %) [mV _{PP}]	< 25		< 120			
Temperature coefficient	-0.015 %/K					
CSB and output decoupled via diode	mounted					
Dynamic control deviations (load change: 10 ... 100 % with 100 Hz; $dI/dt = 0.25 A/\mu s$)						
Control time at $0.01 \times V_{1\text{Nominal}}$ [ms]	<0.5	<0.2	<0.25	<0.1		
Overshoot and under-shoot amplitude [mV]	< 250					

Protection and monitoring facilities

Switch-on time	< 1.5 s				
Mains fuse	4 A/250 V_{AC} , 5 × 20 mm, EN 60127-2/V				
Power failurebridging at $V_{AC} = 90 V_{AC}$ and 100 % load	> 20 ms				
Over-voltage protection OVP set to	7.2 V	8.2 V	19.3 V	34.2 V	
Remote sense compensated	Max. 0.5 V				
"Output voltage ok" signalling	"Output OK" signal, active high				
High level [V]	3.3	5	12	15	20
Time delay	100 – 250 ms				

Test and environmental conditions

Climatic test to	IEC 68-2-38	
Shock and vibration test in accordance with acceleration of 2 g	EN 60068-2-6	
Height 3 U/ depth 160 mm	Width 6 HP	
Weight (mass)	0.55 kg	
CE	Interference emission	EN 50081-1, EN 55011 Class B, EN 55022 Class B
	Interference immunity, degree of severity 3	EN 50082-2, EN 61000-4-2, EN 61000-4-3, EN 61000-4-4, EN 61000-4-5, EN 61000-4-6
	Safety, class of protection 1	EN 60950 (VDE)
High voltage test to EN 60950	Input-output	4.3 kV _{DC}
	Input PE	2.2 kV _{DC}
	Output PE	0.7 kV _{DC}
UL 1950	applied for	
Power supply maintenance-free	Yes	
Cooling	Convection	
Operation/storage ambient temperature	0 ... 70 °C / -20 ... +85 °C	
MTBF at full load, $T_U = 40 °C$	410,000 h (5 V – 240.000 h)	

AC/DC switched mode power supplies

Single, 50 W	3.11.2
Single, 80 W	3.11.4
Single, 100 W	3.11.6
Single, 130 W	3.11.8
Dual, 80 W	3.11.10
Dual, 100 W	3.11.12
Triple, 80 W	3.11.14
Triple, 100 W	3.11.16
Triple, 130 W	3.11.18
Triple, 150 / 224 W	3.11.20
Quad, 250 W	3.11.22
Quad, 350 W	3.11.24

AC/DC linear control systems

Single, 8 – 60 W ..	3.11.26
Dual, 10 – 58 W ...	3.11.28
Triple, 7 – 39 W ...	3.11.30

AC/DC non-regulated

Single, 84 W	3.11.32
Single, 240 W	3.11.34

DC/DC converters

Single, 20 to 120 W	3.11.36
Dual, 55 to 72 W ..	3.11.38
Triple, 64 to 70 W	3.11.40
Quad, 250 W	3.11.42
Quad, 350 W	3.11.44

Accessories

Mating connector female connector H 15 F	3.11.46
Keying/coding	3.11.47
Guide rails	3.11.47
Z-rails	3.11.47
EMC contact strips	3.11.48
Wall/horizontal rail installation	3.11.49

Schematic wiring diagram

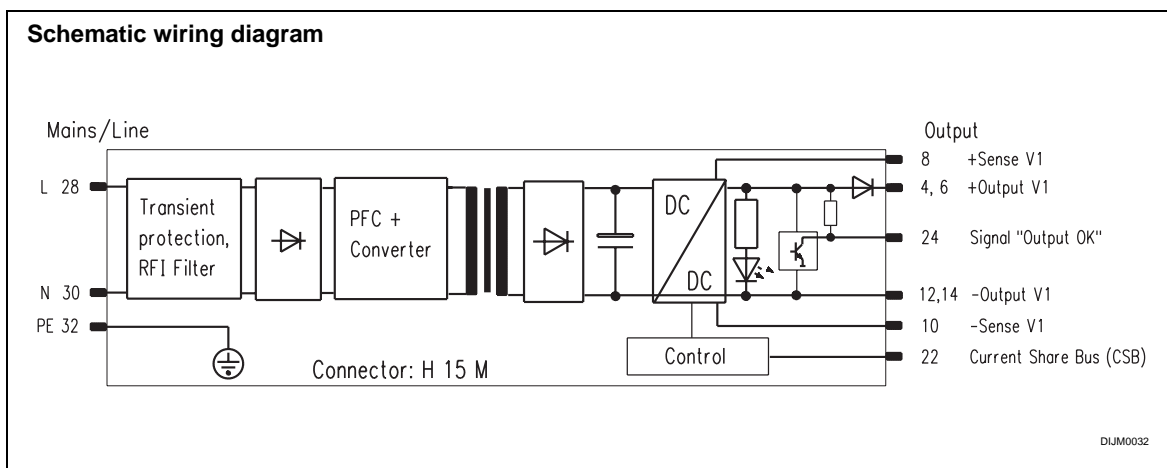



19" compatible AC/DC switched mode

Power supply units..... 3.10.0

19" compatible.....3.11.0

Open frame.....3.12.0

Power systems.....3.13.0

Uninterruptable power supplies (UPS)3.14.0

Backplanes/ test adapters .. 3.20.0

Microcomputer packaging systems (MPS) 3.30.0

Appendix..... 3.90.0



11399005



Single, 100 W

maxpower

- High performance
- 19" compatible AC/DC switched mode power supplies, pluggable 3 U
- Wide range mains input voltage (90 – 254 V_{AC} and 100 – 360 V_{DC})
- Power factor correction (PFC) to EN 61000-3-2
- 1 output voltage
- Redundancy operation with integrated decoupling diode
- Even current share in the event of parallel operation via current share bus (CSB)
- Signalling: Output voltage OK
- For industrial and telecommunications applications
- International approvals EN 60950, UL
- High reliability and long life
- Cost-optimized

100 x 160 mm

DUM0084

PSA46292

Pin	Connection
4	Output + V ₁
6	
8	
8	Sense + V ₁
10	Sense 0V V ₁
12	Output 0V V ₁
14	
16	
18	-
20	-
22	CSB
24	Output OK
26	-
28	L
30	N
32	PE ⊕

Note
The front panel is not included in delivery.

Voltage in V	Output data at T _U = 0 ... 50 °C			Height in U	Width A in HP	Order No. ¹⁾	
	Current (with 190 V _{AC}) in A	Power output in W	Power supply Type			Mains voltage 90 – 254 V _{AC}	Front panel ²⁾ EMC
5	16,0	80	3	6	MAX 105	13100-102	21006-943
12	8.3	100			MAX 112	13100-103	
15	6.6	99			MAX 115	13100-104	
24	4.2	101			MAX 124	13100-105	

¹⁾ Please order front panel separately

²⁾ Front anodised, rear side chromated, slotted on both sides for mounting EMC contact strips in the event of increased EMC requirements
(3 U EMC contact strips, Order No. 21101-705, 10 pieces)

Mating connector H15F with FASTON connection, Order No. 69001-733

19" compatible AC/DC switched mode



Technical data

Input parameters					
Mains-voltage	Nominal values V_{AC}	100 – 240 V_{AC}			
	Operating-ranges	90 – 254 V_{AC} 100 – 360 V_{DC}			
Mains nominal current at 90 V_{AC}	1.6 A				
Mains frequency range	50 – 60 Hz				
Power factor correction in accordance with	EN 61000-3-2				
Efficiency type		63 %	75 %	77 %	
Switch-on current I_p (with 230 V_{AC})	< 20 A				
Output parameters at 190/90 V_{AC}					
Output power max. (50 °C) [W]		80/65	100/72	100/80	
Output voltage [V]	factory set	5	12	15	24
	Adjustment range ΔV	4.95–5.5	11.5–15.7	21.8–25.3	
Output current [A]	0 ... 50 °C	16/13	8.3/6	6.6/4.8	4.2/3.2
	70 °C	12/10.5	6/4.8	4.8/3.8	3.2/2.6
Current limitation shuts the output off after approx. 10 ms, automatically resets after approx. 2 s, shuts power supply off following longer overload.	Permanently short-circuit protected				
Residual ripple/ Interference voltage (BW: 30 MHz) [mV _{PP}]		< 50	< 50	< 60	
Mains and load control, static (load change 0 – 100 %) [mV _{PP}]		< 20	< 80	< 100	< 80
Temperature coefficient	-0.015 %/K				
CSB and output decoupled via diode	mounted				
Dynamic control deviations (load change: 10 ... 100 % with 100 Hz; $dI/dt = 0.25$ A/μs)					
Control time at $0.01 \times V_{1\text{Nominal}}$ [ms]		<0.8	<0.2	<0.1	
Overshoot and undershoot amplitude	< 300 mV				

Protection and monitoring facilities

Switch-on time	< 0.8 s			
Mains fuse	4 A/250 V_{AC} , 5 × 20 mm, EN 60127-2/V			
Power failurebridging at $V_{AC} = 90$ V_{AC} and 100 % load	>14 ms	>14 ms	>10 ms	>16 ms
	<8.2 V	<19 V	<34 V	
	Over-voltage protection OVP limits UA to			
	Remote sense compensated Max. 0.5 V			
"Output voltage ok" signalling	"Output OK" signal, active high			
High level [V]	5	12	15	20
Time delay	100 – 250 ms			

Test and environmental conditions

Climatic test to	IEC 68-2-38			
Shock and vibration test in accordance with acceleration of 2 g	EN 60068-2-6			
Height 3 U/ depth 160 mm	Width 6 HP			
Weight (mass)	0.55 kg			
CE	Interference emission	EN 50081-1, EN 55011 Class B,		
	Interference immunity, degree of severity 3	EN 50082-2, EN 61000-4-2, EN 61000-4-3, EN 61000-4-4, EN 61000-4-5, EN 61000-4-6, EN 61000-4-11		
	Safety, class of protection 1	EN 60950		
High voltage test to EN 60950	Input-output	4.3 kV _{DC}		
	Input PE	2.2 kV _{DC}		
	Output PE	0.7 kV _{DC}		
UL 1950	applied for			
Power supply maintenance-free	Yes			
Cooling	Convection			
Operation/storage ambient temperature	0 ... 70 °C / -20 ... +85 °C			
MTBF at full load, $T_U = 40$ °C	280,000 h (5 V – 220,000 h)			

AC/DC switched mode power supplies

Single, 50 W	3.11.2
Single, 80 W	3.11.4
Single, 100 W	3.11.6
Single, 130 W	3.11.8
Dual, 80 W	3.11.10
Dual, 100 W	3.11.12
Triple, 80 W	3.11.14
Triple, 100 W	3.11.16
Triple, 130 W	3.11.18
Triple, 150 / 224 W	3.11.20
Quad, 250 W	3.11.22
Quad, 350 W	3.11.24

AC/DC linear control systems

Single, 8 – 60 W ..	3.11.26
Dual, 10 – 58 W ...	3.11.28
Triple, 7 – 39 W ...	3.11.30

AC/DC non-regulated

Single, 84 W	3.11.32
Single, 240 W	3.11.34

DC/DC converters

Single, 20 to 120 W	3.11.36
Dual, 55 to 72 W ..	3.11.38
Triple, 64 to 70 W	3.11.40
Quad, 250 W	3.11.42
Quad, 350 W	3.11.44

Accessories

Mating connector female connector H 15 F	3.11.46
Keying/coding	3.11.47
Guide rails	3.11.47
Z-rails	3.11.47
EMC contact strips	3.11.48
Wall/horizontal rail installation	3.11.49

Schematic wiring diagram

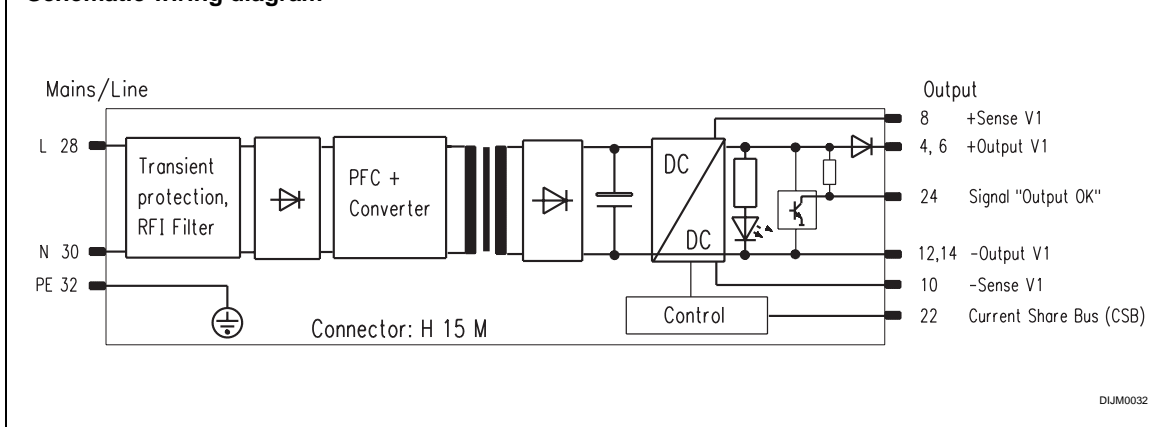



19" compatible AC/DC switched mode

Power supply units..... 3.10.0

19" compatible.....3.11.0

Open frame.....3.12.0

Power systems.....3.13.0

Uninterruptable power supplies (UPS)3.14.0

Backplanes/ test adapters .. 3.20.0

Microcomputer packaging systems (MPS) 3.30.0

Appendix..... 3.90.0



11399008



Single, 130 W

ecopower

- 19" compatible AC/DC switched mode power supplies, pluggable 3 U
- Wide range mains input voltage (90 – 254 V_{AC} and 100 – 360 V_{DC})
- Power factor correction (PFC) to EN 61000-3-2
- 1 output voltage
- Redundancy operation with integrated decoupling diode
- Even current share in the event of parallel operation via current share bus (CSB)
- Signalling: Output voltage OK
- For industrial and telecommunications applications
- International approvals EN 60950, UL
- High reliability and long life
- Cost-optimized

100 x 160 mm

DUM0084

PSA46292

Pin	Connection
4	Output + V ₁
6	
8	Sense + V ₁
10	Sense 0V V ₁
12	
14	Output 0V V ₁
16	
18	
20	
22	CSB
24	Output OK
26	-
28	L
30	N
32	PE ⊕

Note

The front panel is not included in delivery.

Voltage in V	Output data at T _U = 0 ... 50 °C			Height in U	Width A in HP	Order No. ¹⁾	
	Current (with 190 V _{AC}) in A	Power output in W	Power supply Type			Mains voltage 90 – 254 V _{AC}	Front panel ²⁾ EMC
3.3	22,0	72	3	12	SEG 103	13100-090	21006-946
5					SEG 105	13100-091	
12	11,0	SEG 112			13100-092		
15	8.8	SEG 115			13100-093		
24	5.5	SEG 124	13100-094				

¹⁾ Please order front panel separately

²⁾ Front anodised, rear side chromated, slotted on both sides for mounting EMC contact strips in the event of increased EMC requirements
(3 U EMC contact strips, Order No. 21101-705, 10 pieces)

Mating connector H15F with FASTON connection, Order No. 69001-733

19" compatible AC/DC switched mode



Technical data

Input parameters						
Mains-voltage	Nominal values V_{AC}	100 – 240 V_{AC}				
	Operating-ranges	90 – 254 V_{AC} 100 – 360 V_{DC}				
Mains nominal current at 90 V_{AC}	2 A					
Mains frequency range	50 – 60 Hz					
Power factor correction in accordance with	EN 61000-3-2					
Efficiency type	65 %	69 %	80 %	83 %		
Switch-on current I_p (with 230 V_{AC})	< 20 A					
Output parameters at 190/90 V_{AC}						
Output power (50 °C) [W]	72/66	110/100	132/120	132/120		
Output voltage [V]	factory set	3.3	5	12	15	24
	Adjustment range ΔV	2.6–3.5	4.6–5.3	10.6–15.4		21.8–26
Output current [A]	0 ... 50 °C	22/20	11/10	8.8/8	5.5/5	
	UL values	20/18	10.5/9	8.4/7.2	5.5/5	
Current limitation shuts the output off after approx. 5 ms, automatically resets after approx. 2 s, shuts power supply off following longer overload.	Permanently short-circuit resistant					
Residual ripple/ Interference voltage (BW: 30 MHz) [mV_{PP}]	< 200					
Mains and load control, static (load change 0 – 100 %) [mV_{PP}]	< 10	< 20	< 100			
Temperature coefficient	-0.015 %/K					
CSB and output decoupled via diode	mounted					
Dynamic control deviations (load change: 10 ... 100 % with 100 Hz; $dI/dt = 0.25 A/\mu s$)						
Control time at $0.01 \times V_{1\text{Nominal}}$ [ms]	< 0.5					
Overshoot and undershoot amplitude [mV]	< 250					

Protection and monitoring facilities					
Switch-on time	< 1.5 s	< 0.8 s			
Mains fuse	4 A/250 V_{AC} , 5 × 20 mm, EN 60127-2/V				
Power failure bridging at 100 % load	SEG 103, -105, -124 > 20 ms SEG 112 > 10 ms SEG 115 > 5 ms				
Over-voltage protection OVP limits output voltage to	<7.2 V	<8.2 V	<19.5 V	<34.2 V	
Remote sense compensated	Max. 0.5 V				
"Output voltage ok" signalling	"Output OK" signal, active high				
High level [V]	3.3	5	12	15	20
Time delay	100 – 250 ms				
Test and environmental conditions					
Climatic test to	IEC 68-2-38				
Shock and vibration test in accordance with acceleration of 2 g	EN 60068-2-6				
Height 3 U/ depth 160 mm	Width 12 HP				
Weight (mass)	0.9 kg				
CE	Interference emission	EN 50081-1, EN 55011 Class B,			
	interference immunity,	EN 50082-2, EN 61000-4-2, EN 61000-4-3, EN 61000-4-4, EN 61000-4-5, EN 61000-4-6,			
	Safety, class of protection 1	EN 60950			
High voltage test to EN 60950	Input-output	4.3 kV_{DC}			
	Input PE	2.2 kV_{DC}			
	Output PE	0.7 kV_{DC}			
UL 1950	applied for				
Power supply maintenance-free	Yes				
Cooling	Convection				
Operation/storage ambient temperature	0 ... 70 °C / -20 ... +85 °C				
MTBF at full load, $T_U = 40 °C$	310,000 h (5 V – 230,000 h)				

AC/DC switched mode power supplies

Single, 50 W	3.11.2
Single, 80 W	3.11.4
Single, 100 W	3.11.6
Single, 130 W	3.11.8
Dual, 80 W	3.11.10
Dual, 100 W	3.11.12
Triple, 80 W	3.11.14
Triple, 100 W	3.11.16
Triple, 130 W	3.11.18
Triple, 150 / 224 W	3.11.20
Quad, 250 W	3.11.22
Quad, 350 W	3.11.24

AC/DC linear control systems

Single, 8 – 60 W ..	3.11.26
Dual, 10 – 58 W ...	3.11.28
Triple, 7 – 39 W ...	3.11.30

AC/DC non-regulated

Single, 84 W	3.11.32
Single, 240 W	3.11.34

DC/DC converters

Single, 20 to 120 W	3.11.36
Dual, 55 to 72 W ..	3.11.38
Triple, 64 to 70 W	3.11.40
Quad, 250 W	3.11.42
Quad, 350 W	3.11.44

Accessories

Mating connector female connector H 15 F	3.11.46
Keying/coding	3.11.47
Guide rails	3.11.47
Z-rails	3.11.47
EMC contact strips	3.11.48
Wall/horizontal rail installation	3.11.49

Schematic wiring diagram

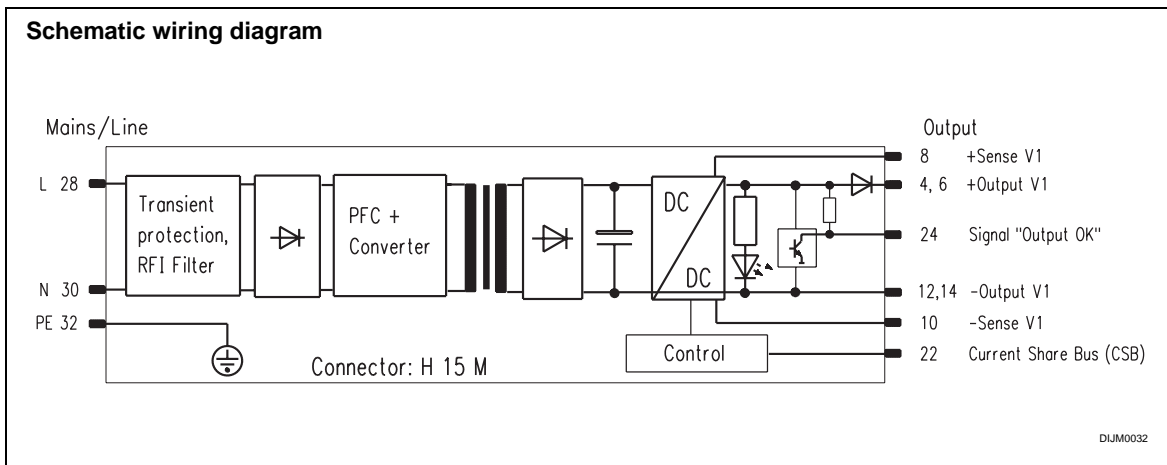



19" compatible AC/DC switched mode

Power supply units..... 3.10.0
19" compatible.....3.11.0
 Open frame.....3.12.0
 Power systems.....3.13.0
 Uninterruptable power supplies (UPS)3.14.0

Backplanes/ test adapters .. 3.20.0

Microcomputer packaging systems (MPS) 3.30.0

Appendix..... 3.90.0



11399006

Dual, 80 W

ecopower

- 19" compatible AC/DC switched mode power supplies, pluggable 3 U
- Wide range mains input voltage (90 – 254 V_{AC} and 100 – 360 V_{DC})
- Power factor correction (PFC) to EN 61000-3-2
- 2 output voltages
- For industrial applications
- International approvals EN 60950, UL
- High reliability and long life
- Cost-optimized

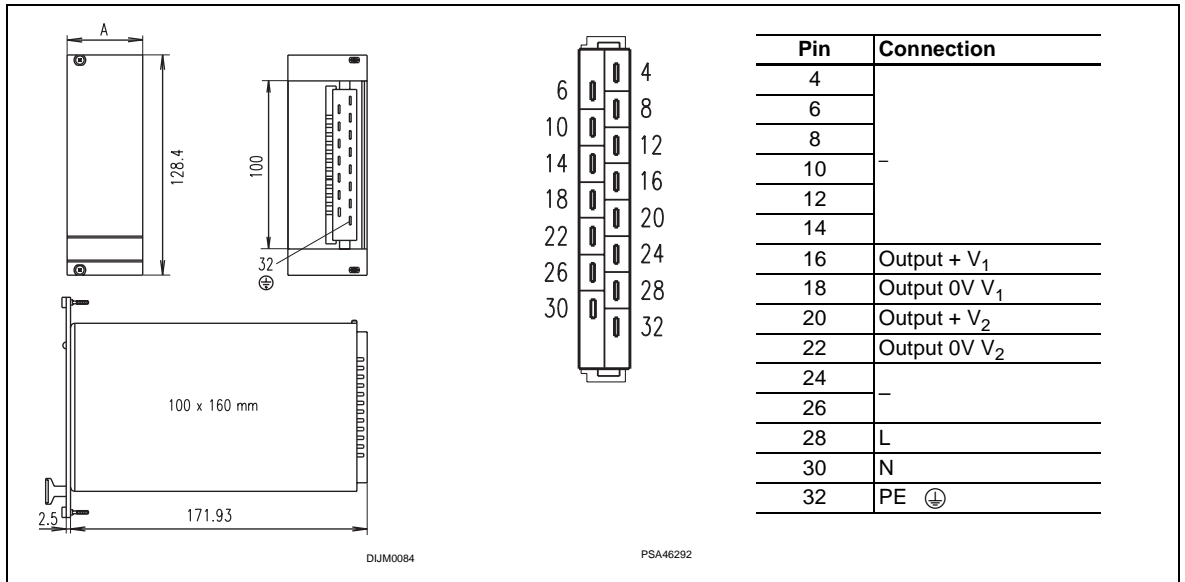

Note

The front panel is not included in delivery.

Output data at T _U = 0 ... 50 °C					Order No. ¹⁾				
Voltage in V		Current (with 190 V _{AC}) in A		Power output in W	Height in U	Width A in HP	Power supply Type	Mains voltage 90 – 254 V _{AC}	Front panel ²⁾ EMC
V ₁	V ₂	I ₁	I ₂						
+5	+12	7	3.5	75	3	8	SEM 2512	13100-066	21006-945
+5	+24	7	1.8	78			SEM 2524	13100-067	
+12	-12	3.5	3.5	84			SEM 212	13100-064	
+15	-15	2.8	2.8				SEM 215	13100-068	

¹⁾ Please order front panel separately

²⁾ Front anodised, rear side chromated, slotted on both sides for mounting EMC contact strips in the event of increased EMC requirements (3 U EMC contact strips, Order No. 21101-705, 10 pieces)

Mating connector H15F with FASTON connection, Order No. 69001-733

19" compatible AC/DC switched mode



Technical data

Input parameters					
Mains-voltage	Nominal values V_{AC}	100 – 240 V_{AC}			
	Operating-ranges	90 – 254 V_{AC} 100 – 360 V_{DC}			
Mains nominal current at 90 V_{AC}		1.4 A			
Mains frequency range		50 – 60 Hz			
Power factor correction in accordance with		EN 61000-3-2			
Efficiency type		74 – 80 %			
Switch-on current I_p (with 230 V_{AC})		< 15 A			
Output parameters at		190/90 V_{AC}			
Output power max.		75 – 84 / 66 – 72 W			
Output voltage [V]		V_1, V_2			
	factory set	5	12	15	24
	Adjustment-range ΔV	4.95–5.5	11.5–15.7		24–25.2
Output current [A]	0 ... 50°C V_1	7/6	3.5/3	2.8/2.4	1.8/1.3
	V_2		3.5/3	2.8/2.4	
	70°C V_1	5/4	2.7/2.2	2.2/1.8	1/0.8
	V_2		2.7/2.2	2.2/1.8	
Current limitation shuts the output off after approx. 20 ms, automatically resets after approx. 2 s		Permanently short-circuit protected			
Residual ripple/interference voltage (BW: 30 MHz) [mV _{PP}]		< 150			
Mains and load control, static (load change 0 – 100 %) [mV _{PP}]		< 100	< 120	< 150	< 100
Temperature coefficient		-0.015 %/K			
Dynamic control deviations					
(load change: 10 ... 100 % with 100 Hz; $di/dt = 0.25$ A/ μ s)					
Control time at $0.01 \times V_1$ Nominal [ms]		< 0.3			
Overshoot and undershoot amplitude [mV]		< 200	< 250	< 100	

Protection and monitoring facilities				
Switch-on time		< 1.5 s		
Mains fuse		4 A/250 V_{AC} , 5 × 20 mm, EN 60127-2/V		
Power failurebridging at $V_{AC} = 90$ V_{AC} and 100 % load		> 20 ms		
Over-voltage protection OVP		7.5 V	18 V	30 V
Test and environmental conditions				
Climatic test to		IEC 68-2-38		
Shock and vibration test in accordance with acceleration of 2 g		EN 60068-2-6		
Height 3 U/depth 160 mm		Width 8 HP		
Weight (mass)		0.55 kg		
CE	Interference emission	EN 50081-1, EN 55011 Class B,		
	interference-immunity, degree of severity 3	EN 50082-2, EN 61000-4-2, EN 61000-4-3, EN 61000-4-4, EN 61000-4-5, EN 61000-4-6,		
	Safety, class of protection 1	EN 60950		
High voltage test to EN 60950	Input-output	4.3 kV _{DC}		
	Input PE	2.2 kV _{DC}		
	Output PE	0.7 kV _{DC}		
UL 1950		applied for		
Power supply maintenance-free		Yes		
Cooling		Convection		
Operation/storage ambient temperature		0 ... 70°C / -20 ... +85°C		
MTBF at full load, $T_U = 40^\circ\text{C}$		350,000 h		

AC/DC switched mode power supplies

Single, 50 W	3.11.2
Single, 80 W	3.11.4
Single, 100 W	3.11.6
Single, 130 W	3.11.8
Dual, 80 W	3.11.10
Dual, 100 W	3.11.12
Triple, 80 W	3.11.14
Triple, 100 W	3.11.16
Triple, 130 W	3.11.18
Triple, 150 / 224 W	3.11.20
Quad, 250 W	3.11.22
Quad, 350 W	3.11.24

AC/DC linear control systems

Single, 8 – 60 W ..	3.11.26
Dual, 10 – 58 W ...	3.11.28
Triple, 7 – 39 W ...	3.11.30

AC/DC non-regulated

Single, 84 W	3.11.32
Single, 240 W	3.11.34

DC/DC converters

Single, 20 to 120 W	3.11.36
Dual, 55 to 72 W ..	3.11.38
Triple, 64 to 70 W	3.11.40
Quad, 250 W	3.11.42
Quad, 350 W	3.11.44

Accessories

Mating connector female connector H 15 F	3.11.46
Keying/coding	3.11.47
Guide rails	3.11.47
Z-rails	3.11.47
EMC contact strips	3.11.48
Wall/horizontal rail installation	3.11.49

Schematic wiring diagram

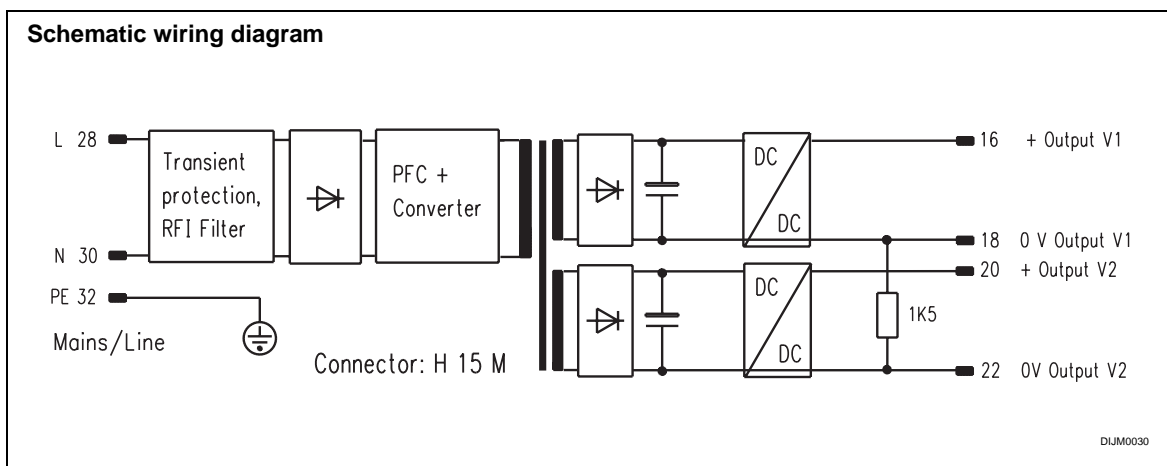



19" compatible AC/DC switched mode

Power supply units..... 3.10.0

19" compatible.....3.11.0

Open frame.....3.12.0

Power systems.....3.13.0

Uninterruptable power supplies (UPS)3.14.0

Backplanes/ test adapters .. 3.20.0

Microcomputer packaging systems (MPS) 3.30.0

Appendix..... 3.90.0



11300010

Dual, 100 W

maxpower

- 19" compatible AC/DC switched mode power supplies, pluggable 3 U
- Wide range mains input voltage (90 – 254 V_{AC} and 100 – 360 V_{DC})
- Power factor correction (PFC) to EN 61000-3-2
- 2 output voltages
- For industrial applications
- International approvals EN 60950, UL
- High reliability and long life
- Cost-optimized



100 x 160 mm

DUM0084

PSA46292

Pin	Connection
4	
6	
8	
10	
12	
14	
16	Output + V ₁
18	Output 0V V ₁
20	Output + V ₂
22	Output 0V V ₂
24	
26	
28	L
30	N
32	PE ⊕

Note

The front panel is not included in delivery.

Output data at T _U = 0 ... 50 °C					Order No. ¹⁾				
Voltage in V		Current (with 190 V) in A		Power output in W	Height in U	Width A in HP	Power supply Type	Mains voltage 90 – 254 V _{AC}	Front panel ²⁾ EMC
V ₁	V ₂	I ₁	I ₂						
+5	+12	9	4	93	3	8	MAX 2512	13100-112	21006-945
+5	+24	9	2				MAX 2524	13100-114	
+12	-12	4.2	4.2	MAX 212			13100-115		
+15	-15	3.4	3.4	MAX 215			13100-116		

¹⁾ Please order front panel separately

²⁾ Front anodised, rear side chromated, slotted on both sides for mounting EMC contact strips in the event of increased EMC requirements (3 U EMC contact strips, Order No. 21101-705, 10 pieces)

Mating connector H15F with FASTON connection, Order No. 69001-733

19" compatible AC/DC switched mode



Technical data

Input parameters					
Mains-voltage	Nominal values V_{AC}	100 – 240 V_{AC}			
	Operating-ranges	90 – 254 V_{AC} 100 – 360 V_{DC}			
Mains nominal current at 90 V_{AC}		1.4 A			
Mains frequency range		50 – 60 Hz			
Power factor correction in accordance with		EN 61000-3-2			
Efficiency type		73 – 80 %			
Switch-on current I_p (with 230 V_{AC})		< 15 A			
Output parameters at		190/90 V_{AC}			
Output power max.		93 – 102 / 77 – 82 W			
Output voltage [V]		V_1, V_2			
	factory set	5	12	15	24
	Adjustment-range ΔV	4.95–5.5	11.5–15.7	24–25.2	
Output current [A]	0 ... 50°C V_1	9/7	4.2/3.4	3.4/2.7	2/1.6
	70°C V_1 V_2	6/5	3.2/2.5 3.2/2.5	2.6/2 2.6/2	
Current limitation shuts the output off after approx. 20 ms, automatically resets after approx. 2 s		Permanently short-circuit protected			
Residual ripple/interference voltage (BW: 30 MHz) [mV _{PP}]		< 100	< 80	< 100	
		< 100	< 150	< 150	< 100
Mains and load control, static (load change 0 – 100 %) [mV _{PP}]		< 100	< 150	< 150	< 100
Temperature coefficient		-0.015 %/K			
Dynamic control deviations (load change: 10 ... 100 % with 100 Hz; $dI/dt = 0.25$ A/ μ s)					
Control time at $0.01 \times V_1$ Nominal		< 0.8 ms			
Overshoot and undershoot amplitude		< 250 mV			

Protection and monitoring facilities					
		5 V	12 V	15 V	24 V
Switch-on time		< 1.5 s			
Mains fuse		4 A/250 V_{AC} , 5 × 20 mm, EN 60127-2/V			
Power failure bridging at $V_{AC} = 90$ V_{AC} and 100 % load		> 10 ms	> 7 ms	> 20 ms	
Over-voltage protection OVP (shuts power supply off)		7.5 V	18 V	30 V	
Test and environmental conditions					
Climatic test to		IEC 68-2-38			
Shock and vibration test in accordance with acceleration of 2 g		EN 60068-2-6			
Height 3 U/depth 160 mm		Width 8 HP			
Weight (mass)		0.55 kg			
CE	Interference emission	EN 50081-1, EN 55011 Class B,			
	interference-immunity, degree of severity 3	EN 50082-2, EN 61000-4-2, EN 61000-4-3, EN 61000-4-4, EN 61000-4-5, EN 61000-4-6,			
	Safety, class of protection 1	EN 60950			
High voltage test to EN 60950	Input-output	4.3 kV _{DC}			
	Input PE	2.2 kV _{DC}			
	Output PE	0.7 kV _{DC}			
UL 1950		applied for			
Power supply maintenance-free		Yes			
Cooling		Convection			
Operation/storage ambient temperature		0 ... 70°C / -20 ... +85°C			
MTBF at full load, $T_U = 40^\circ\text{C}$		250,000 h			

AC/DC switched mode power supplies

Single, 50 W	3.11.2
Single, 80 W	3.11.4
Single, 100 W	3.11.6
Single, 130 W	3.11.8
Dual, 80 W	3.11.10
Dual, 100 W	3.11.12
Triple, 80 W	3.11.14
Triple, 100 W	3.11.16
Triple, 130 W	3.11.18
Triple, 150 / 224 W	3.11.20
Quad, 250 W	3.11.22
Quad, 350 W	3.11.24

AC/DC linear control systems

Single, 8 – 60 W ..	3.11.26
Dual, 10 – 58 W ...	3.11.28
Triple, 7 – 39 W ...	3.11.30

AC/DC non-regulated

Single, 84 W	3.11.32
Single, 240 W	3.11.34

DC/DC converters

Single, 20 to 120 W	3.11.36
Dual, 55 to 72 W ..	3.11.38
Triple, 64 to 70 W	3.11.40
Quad, 250 W	3.11.42
Quad, 350 W	3.11.44

Accessories

Mating connector female connector H 15 F	3.11.46
Keying/coding	3.11.47
Guide rails	3.11.47
Z-rails	3.11.47
EMC contact strips	3.11.48
Wall/horizontal rail installation	3.11.49

Schematic wiring diagram

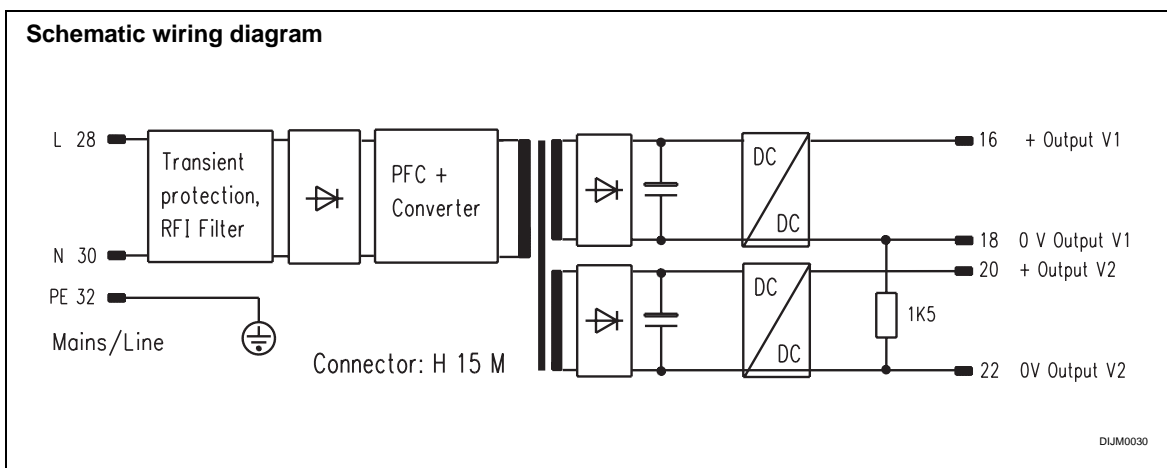



19" compatible AC/DC switched mode

Power supply units..... 3.10.0
19" compatible.....3.11.0
 Open frame.....3.12.0
 Power systems.....3.13.0
 Uninterruptable power supplies (UPS)3.14.0

Backplanes/ test adapters .. 3.20.0

Microcomputer packaging systems (MPS) 3.30.0

Appendix..... 3.90.0



11399007

Triple, 80 W

ecopower

- 19" compatible AC/DC switched mode power supplies, pluggable 3 U
- Wide range mains input voltage (90 – 254 V_{AC} and 100 – 360 V_{DC})
- Power factor correction (PFC) to EN 61000-3-2
- 3 output voltages
- Signalling: Output voltage OK
- For industrial applications
- International approvals EN 60950, UL
- High reliability and long life
- Cost-optimized



100 x 160 mm

DUM0084

PSA46292

Pin	Connection
4	Output + V ₁
6	
8	Sense + V ₁
10	Sense 0V V ₁
12	
14	Output 0V V ₁ (V ₂)
16	Output + V ₂
18	Output 0V V ₂ (V ₁)
20	Output 0V V ₃
22	Output - V ₃
24	Output OK
26	-
28	L
30	N
32	PE ⊕

Note

The front panel is not included in delivery.

Output data at T _U = 0 ... 50 °C							Order No. ¹⁾				
Voltage in V			Current (with 190 V _{AC}) in A			Power output in W	Height in U	Width A in HP	Power supply Type	Mains voltage 90 – 254 V _{AC}	Front panel ²⁾ EMC
V ₁	V ₂	V ₃	I ₁	I ₂	I ₃						
+5	+12	-12	7	1,9	1,9	81	3	8	SEM 312	13100-069	21006-945
+5	+15	-15	7	1.5	1.5	80			SEM 315	13100-070	

¹⁾ Please order front panel separately

²⁾ Front anodised, rear side chromated, slotted on both sides for mounting EMC contact strips in the event of increased EMC requirements
 (3 U EMC contact strips, Order No. 21101-705, 10 pieces)

Mating connector H15F with FASTON connection, Order No. 69001-733

19" compatible AC/DC switched mode



Technical data

Input parameters			
Mains-voltage	Nominal values V_{AC}	100 – 240 V_{AC}	
	Operating-ranges	90 – 254 V_{AC} 100 – 360 V_{DC}	
Mains nominal current at 90 V_{AC}		1.4 A	
Mains frequency range		50 – 60 Hz	
Power factor correction in accordance with		EN 61000-3-2	
Efficiency type		> 74 %	
Switch-on current I_p (with 230 V_{AC})		< 15 A	
Output parameters at		190/90 V_{AC}	
Output power max. (50°C) [W]		35/25	45/31
Output voltage [V]		V_1	V_2, V_3
	factory set	5 V	± 12 V ± 15 V
	Adjustment-range ΔV	4.95–5.5	11.5–15.7 11.5–15.7
Output current [A]	0 ... 50°C	7/6.5	1.9/1.4 1.5/1.1
	70°C	5/5	1.3/1 1.0/0.8
Current limitation shuts the output off after approx. 20 ms, automatically resets after approx. 0.5 s		Permanently short-circuit protected	
Residual ripple/interference voltage (BW: 30 MHz) [mV_{PP}]		< 120	< 300
	Mains and load control, static (load change 0 – 100 %) [mV_{PP}]	< 50	< 120
Temperature coefficient		-0.015 %/K	
Dynamic control deviations			
(load change: 10 ... 100 % with 100 Hz; $di/dt = 0.25$ A/ μ s)			
Control time at $0.01 \times V_1$ Nominal [ms]		< 0.8	
Overshoot and undershoot amplitude [mV]		< 250	

Protection and monitoring facilities			
Switch-on time		< 1.5 s	
Mains fuse		4 A/250 V_{AC} , 5 × 20 mm, EN 60127-2/V	
Power failure bridging at $V_{AC} = 90$ V_{AC} and 100 % load		> 20 ms	
Over-voltage protection OVP (shuts power supply off)		V_1 : 7.5 V	
"Output voltage ok" signalling		"Output OK" signal, active high	
Test and environmental conditions			
Climatic test to		IEC 68-2-38	
Shock and vibration test in accordance with acceleration of 2 g		EN 60068-2-6	
Height 3 U/depth 160 mm		Width 8 HP	
Weight (mass)		0.55 kg	
CE	Interference emission	EN 50081-1, EN 55011 Class B,	
	interference-immunity, degree of severity 3	EN 50082-2, EN 61000-4-2, EN 61000-4-3, EN 61000-4-4, EN 61000-4-5, EN 61000-4-6,	
	Safety, class of protection 1	EN 60950 (VDE)	
High voltage test to EN 60950	Input-output	4.3 kV $_{DC}$	
	Input PE	2.2 kV $_{DC}$	
	Output PE	0.7 kV $_{DC}$	
UL 1950		E 153809	
Power supply maintenance-free		Yes	
Cooling		Convection	
Operation/storage ambient temperature		0 ... 70°C / -20 ... +85°C	
MTBF at full load, $T_U = 40$ °C		300,000 h	

AC/DC switched mode power supplies

Single, 50 W	3.11.2
Single, 80 W	3.11.4
Single, 100 W	3.11.6
Single, 130 W	3.11.8
Dual, 80 W	3.11.10
Dual, 100 W	3.11.12
Triple, 80 W	3.11.14
Triple, 100 W	3.11.16
Triple, 130 W	3.11.18
Triple, 150 / 224 W	3.11.20
Quad, 250 W	3.11.22
Quad, 350 W	3.11.24

AC/DC linear control systems

Single, 8 – 60 W ..	3.11.26
Dual, 10 – 58 W ...	3.11.28
Triple, 7 – 39 W ...	3.11.30

AC/DC non-regulated

Single, 84 W	3.11.32
Single, 240 W	3.11.34

DC/DC converters

Single, 20 to 120 W	3.11.36
Dual, 55 to 72 W ..	3.11.38
Triple, 64 to 70 W	3.11.40
Quad, 250 W	3.11.42
Quad, 350 W	3.11.44

Accessories

Mating connector female connector H 15 F	3.11.46
Keying/coding	3.11.47
Guide rails	3.11.47
Z-rails	3.11.47
EMC contact strips	3.11.48
Wall/horizontal rail installation	3.11.49

Schematic wiring diagram

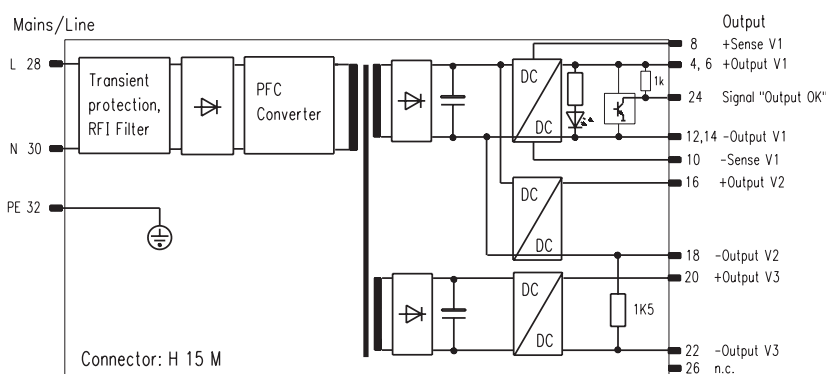

DJUM0026



19" compatible AC/DC switched mode

Power supply units..... 3.10.0

19" compatible.....3.11.0

Open frame.....3.12.0

Power systems.....3.13.0

Uninterruptable power supplies (UPS)3.14.0

Backplanes/ test adapters .. 3.20.0

Microcomputer packaging systems (MPS) 3.30.0

Appendix..... 3.90.0



11300011

Triple, 100 W

maxpower

- 19" compatible AC/DC switched mode power supplies, pluggable 3 U
- Wide range mains input voltage (90 – 254 V_{AC} and 100 – 360 V_{DC})
- Power factor correction (PFC) to EN 61000-3-2
- 3 output voltages
- Signalling: Output voltage OK
- For industrial applications
- International approvals EN 60950, UL
- High reliability and long life
- Cost-optimized



DUM0084

PSA46292

Pin	Connection
4	Output + V ₁
6	
8	Sense + V ₁
10	Sense 0V V ₁
12	
14	Output 0V V ₁ (V ₂)
16	Output + V ₂
18	Output 0V V ₂ (V ₁)
20	Output 0V V ₃
22	Output - V ₃
24	Output OK
26	-
28	L
30	N
32	PE ⊕

Note

The front panel is not included in delivery.

Output data at T _U = 0 ... 50 °C							Order No. ¹⁾				
Voltage in V			Current (with 190 V _{AC}) in A			Power output	Height	Width A	Power supply	Mains voltage	Front panel ²⁾ EMC
V ₁	V ₂	V ₃	I ₁	I ₂	I ₃	in W	in U	in HP	Type	90 – 254 V _{AC}	
+5	+12	-12	8	2.5	2.5	100	3	8	MAX 312	13100-122	21006-945
+5	+15	-15	8	2,0	2,0				MAX 315	13100-123	

¹⁾ Please order front panel separately

²⁾ Front anodised, rear side chromated, slotted on both sides for mounting EMC contact strips in the event of increased EMC requirements

3 U EMC contact strips, Order No. 21101-705, 10 pieces

Mating connector H15F with FASTON connection, Order No. 69001-733

19" compatible AC/DC switched mode



Technical data

Input parameters			
Mains-voltage	Nominal values V_{AC}	100 – 240 V_{AC}	
	Operating-ranges	90 – 254 V_{AC} 100 – 360 V_{DC}	
Mains nominal current at 90 V_{AC}		1.4 A	
Mains frequency range		50 – 60 Hz	
Power factor correction in accordance with		EN 61000-3-2	
Efficiency type		> 73 %	
Switch-on current I_p (with 230 V_{AC})		< 15 A	
Output parameters at		190/90 V_{AC}	
Output power max. (50°C) [W]		40/35	60/38.4
Output voltage [V]		V_1	V_2, V_3
	factory set	5 V	$\pm 12 V$ $\pm 15 V$
	Adjustment-range ΔV	4.95–5.5	11.5–15.7 11.5–15.7
Output current [A]	0 ... 50°C	8/7	2.5/1.6 2/1.3
	70°C	6/5.5	1.5/1.2 1.2/1
Current limitation shuts the output off after approx. 20 ms, automatically resets after approx. 0.5 s		Permanently short-circuit protected	
Residual ripple/interference voltage (BW: 30 MHz) [mV_{PP}]		< 80	< 150
Mains and load control, static (load change 0 – 100 %) [mV_{PP}]		< 25	< 120
Temperature coefficient		-0.015 %/K	
Dynamic control deviations (load change: 10 ... 100 % with 100 Hz; $di/dt = 0.25 A/\mu s$)			
Control time at $0.01 \times V_1$ Nominal [ms]		< 0.8	
Overshoot and undershoot amplitude [mV]		< 250	

Protection and monitoring facilities			
Switch-on time		< 1.5 s	
Mains fuse, high breaking sluggish		4 A/250 V_{AC} , 5 × 20 mm, DIN EN 60127-2/V	
Power failure bridging at $V_{AC} = 90 V_{AC}$ and 100 % load $V_1/V_{2,3}$		> 16 ms/5 ms	
Over-voltage protection OVP (shuts power supply off, diode alloyed through) set to		< 7.2 V	–
Remote sense compensated		Max. 0.5 V	
"Output voltage ok"		"Output OK" signal, active high signalling	
Test and environmental conditions			
Climatic test to		IEC 68-2-38	
Shock and vibration test in accordance with acceleration of 2 g		EN 60068-2-6	
Height 3 U/depth 160 mm		Width 8 HP	
Weight (mass)		0.55 kg	
CE	Interference emission	EN 50081-1, EN 55011 Class B,	
	interference-immunity, degree of severity 3	EN 50082-2, EN 61000-4-2, EN 61000-4-3, EN 61000-4-4, EN 61000-4-5, EN 61000-4-6,	
	Safety, class of protection 1	EN 60950	
High voltage test to EN 60950	Input-output	4.3 kV_{DC}	
	Input PE	2.2 kV_{DC}	
	Output PE	0.7 kV_{DC}	
UL 1950		applied for	
Power supply maintenance-free		Yes	
Cooling		Convection	
Operation/storage ambient temperature		0 ... 70°C / -20 ... +85°C	
MTBF at full load, $T_U = 40^\circ C$		220,000 h	

AC/DC switched mode power supplies

Single, 50 W	3.11.2
Single, 80 W	3.11.4
Single, 100 W	3.11.6
Single, 130 W	3.11.8
Dual, 80 W	3.11.10
Dual, 100 W	3.11.12
Triple, 80 W	3.11.14
Triple, 100 W	3.11.16
Triple, 130 W	3.11.18
Triple, 150 / 224 W	3.11.20
Quad, 250 W	3.11.22
Quad, 350 W	3.11.24

AC/DC linear control systems

Single, 8 – 60 W ..	3.11.26
Dual, 10 – 58 W ...	3.11.28
Triple, 7 – 39 W ...	3.11.30

AC/DC non-regulated

Single, 84 W	3.11.32
Single, 240 W	3.11.34

DC/DC converters

Single, 20 to 120 W	3.11.36
Dual, 55 to 72 W ..	3.11.38
Triple, 64 to 70 W	3.11.40
Quad, 250 W	3.11.42
Quad, 350 W	3.11.44

Accessories

Mating connector female connector H 15 F	3.11.46
Keying/coding	3.11.47
Guide rails	3.11.47
Z-rails	3.11.47
EMC contact strips	3.11.48
Wall/horizontal rail installation	3.11.49

Schematic wiring diagram

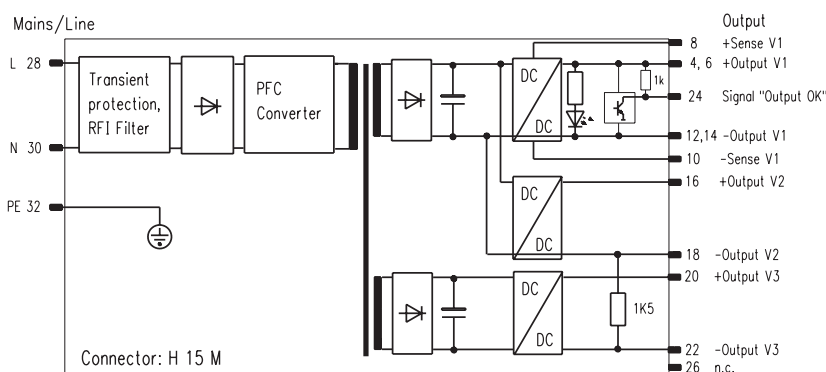

DJUM0026



19" compatible AC/DC switched mode

Power supply units..... 3.10.0

19" compatible.....3.11.0

Open frame.....3.12.0

Power systems.....3.13.0

Uninterruptable power supplies (UPS)3.14.0

Backplanes/ test adapters .. 3.20.0

Microcomputer packaging systems (MPS) 3.30.0

Appendix..... 3.90.0



11399009

Triple, 130 W

ecopower

- 19" compatible AC/DC switched mode power supplies, pluggable 3 U
- Wide range mains input voltage (90 – 254 V_{AC} and 100 – 360 V_{DC})
- Power factor correction (PFC) to EN 61000-3-2
- 3 output voltages
- Signalling: Output voltage OK
- For industrial applications
- International approvals EN 60950, UL
- High reliability and long life
- Cost-optimized



100 x 160 mm

DUM0084

PSA46292

Pin	Connection
4	Output + V ₁
6	Sense + V ₁
8	Sense 0V V ₁
10	Output 0V V ₁ (V _{2,3})
12	Output + V ₂
14	Output 0V V _{2,3} (V ₁)
16	Output - V ₃
18	Output OK
20	-
22	-
24	-
26	-
28	L
30	N
32	PE ⊕

Note

The front panel is not included in delivery.

Output data at mains voltage 190 V, T _U = 0 ... 50 °C							Order No. ¹⁾				
Voltage in V			Current (with 190 V _{AC}) in A			Power output in W	Height in U	Width A in HP	Power supply Type	Mains voltage	Front panel ²⁾ EMC
V ₁	V ₂	V ₃	I ₁	I ₂	I ₃					90 – 254 V _{AC}	
+5	+12	-12	16	2.8	1.4	132	3	12	SEG 312	13100-078	21006-946
+5	+15	-15	16	2.2	1.1	132			SEG 315	13100-079	

¹⁾ Please order front panel separately

²⁾ Front anodised, rear side chromated, slotted on both sides for mounting EMC contact strips in the event of increased EMC requirements
(3 U EMC contact strips, Order No. 21101-705, 10 pieces)

Mating connector H15F with FASTON connection, Order No. 69001-733

19" compatible AC/DC switched mode



Technical data

Input parameters				
Mains-voltage (wide range input)	Nominal values V_{AC}	100 – 240 V_{AC}		
	Operating-ranges	90 – 254 V_{AC} 100 – 360 V_{DC}		
Mains nominal current at 90 V_{AC}	2 A			
Mains frequency range	50 – 60 Hz			
Power factor correction in accordance with	EN 61000-3-2			
Efficiency type	75 %			
Switch-on current I_p (with 230 V_{AC})	< 15 A			
Output parameters at		190/90 V_{AC}		
Output power max. (50°C) [W]	80/65	67/33		
Output voltage [V]	factory set	V_1	V_2, V_3	
	Adjustment-range ΔV	5 V	$\pm 12 V$	$\pm 15 V$
Output current [A]	0 ... 50°C	4.6–5.3	11.1–15.8	
	70°C	16/13	2.8/1.4	2.2/1.1
	UL values (50°C)	11/8	2/1	1.6/0.67
Current limitation shuts the output off after approx. 14 ms, automatically resets after approx. 0.2 s	Permanently short-circuit protected			
Residual ripple/interferencevoltage (BW: 30 MHz) [mV _{PP}]	< 250		< 350	
Mains and load control, static (load change 0 – 100 %) [mV _{PP}]	< 30		< 90	
Temperature coefficient	-0.015 %/K			
Dynamic control deviations				
(load change: 10 ... 100 % with 100 Hz; U_3 : 20 ... 100 %; $di/dt = 0.25 A/\mu s$)				
Control time at $0.01 \times V_{1 \text{ Nominal}}$ [ms]	< 0.5			
Overshoot and undershoot amplitude [mV]	< 250	< 250/550	< 300	

Protection and monitoring facilities			
Switch-on time	< 2 s		
Mains fuse	4 A/250 V_{AC} , 5 × 20 mm, EN 60127-2/V		
Power failurebridging at 100 % load	> 5 ms		
Over-voltage protection OVP typically limits output voltage to	6.3 V	13 V	16.2 V
Remote sense compensated per line	Max. 0.25 V		
"Output voltage ok" signalling	active high		
High level	5 V		
Time delay	100 – 250 ms		
Test and environmental conditions			
Climatic test to	IEC 68-2-38		
Shock and vibration test in accordance with acceleration of 2 g	EN 60068-2-6		
Height 3 U/depth 160 mm	Width 12 HP		
Weight (mass)	0.8 kg		
CE	Interference-emission	EN 50081-1, EN 55011 Class B,	
	interference-immunity, degree of severity 3	EN 50082-2, EN 61000-4-2, EN 61000-4-3, EN 61000-4-4, EN 61000-4-5, EN 61000-4-6	
	Safety, class of protection 1	EN 60950	
High voltage test to EN 60950	Input-output	4.3 kV _{DC}	
	Input PE	2.2 kV _{DC}	
	Output PE	0.7 kV _{DC}	
	Output-output	0.7 kV _{DC}	
UL 1950	applied for		
Power supply maintenance-free	Yes		
Cooling	Convection		
Operation/storage ambient temperature	0 ... 70°C / -20 ... +85°C		
MTBF at full load, $T_U = 40^\circ C$	200,000 h		

AC/DC switched mode power supplies

Single, 50 W	3.11.2
Single, 80 W	3.11.4
Single, 100 W	3.11.6
Single, 130 W	3.11.8
Dual, 80 W	3.11.10
Dual, 100 W	3.11.12
Triple, 80 W	3.11.14
Triple, 100 W	3.11.16
Triple, 130 W	3.11.18
Triple, 150 / 224 W	3.11.20
Quad, 250 W	3.11.22
Quad, 350 W	3.11.24

AC/DC linear control systems

Single, 8 – 60 W ..	3.11.26
Dual, 10 – 58 W ...	3.11.28
Triple, 7 – 39 W ...	3.11.30

AC/DC non-regulated

Single, 84 W	3.11.32
Single, 240 W	3.11.34

DC/DC converters

Single, 20 to 120 W	3.11.36
Dual, 55 to 72 W ..	3.11.38
Triple, 64 to 70 W	3.11.40
Quad, 250 W	3.11.42
Quad, 350 W	3.11.44

Accessories

Mating connector female connector H 15 F	3.11.46
Keying/coding	3.11.47
Guide rails	3.11.47
Z-rails	3.11.47
EMC contact strips	3.11.48
Wall/horizontal rail installation	3.11.49

Schematic wiring diagram

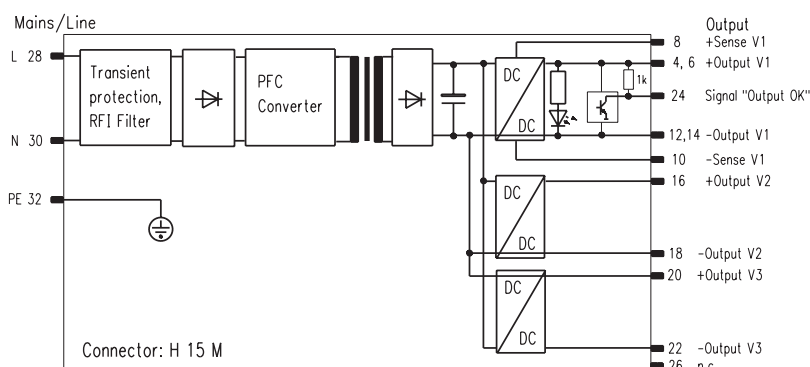

DJUM0074



19" compatible AC/DC switched mode

Power supply units..... 3.10.0

19" compatible.....3.11.0

Open frame.....3.12.0

Power systems.....3.13.0

Uninterruptable power supplies (UPS)3.14.0

Backplanes/ test adapters .. 3.20.0

Microcomputer packaging systems (MPS) 3.30.0

Appendix..... 3.90.0

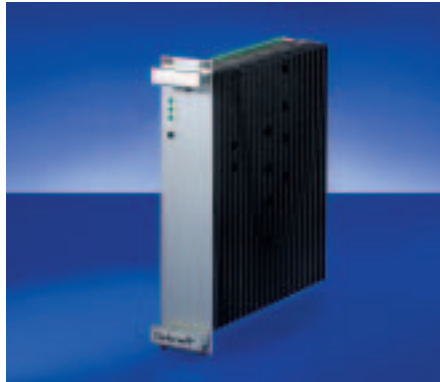

11301002

Triple, 150 / 224 W

- MPS series
- 19" compatible AC/DC switched mode power supplies, pluggable 6 U, for VME bus and other applications
- Wide range input voltage (90 – 264 V_{AC} and 130 – 350 V_{DC})
- Power factor correction (PFC) to EN 61000-3-2
- 3 output voltages
- VME bus signalling
- For industrial applications
- International approvals EN 60950, UL
- High reliability and long life

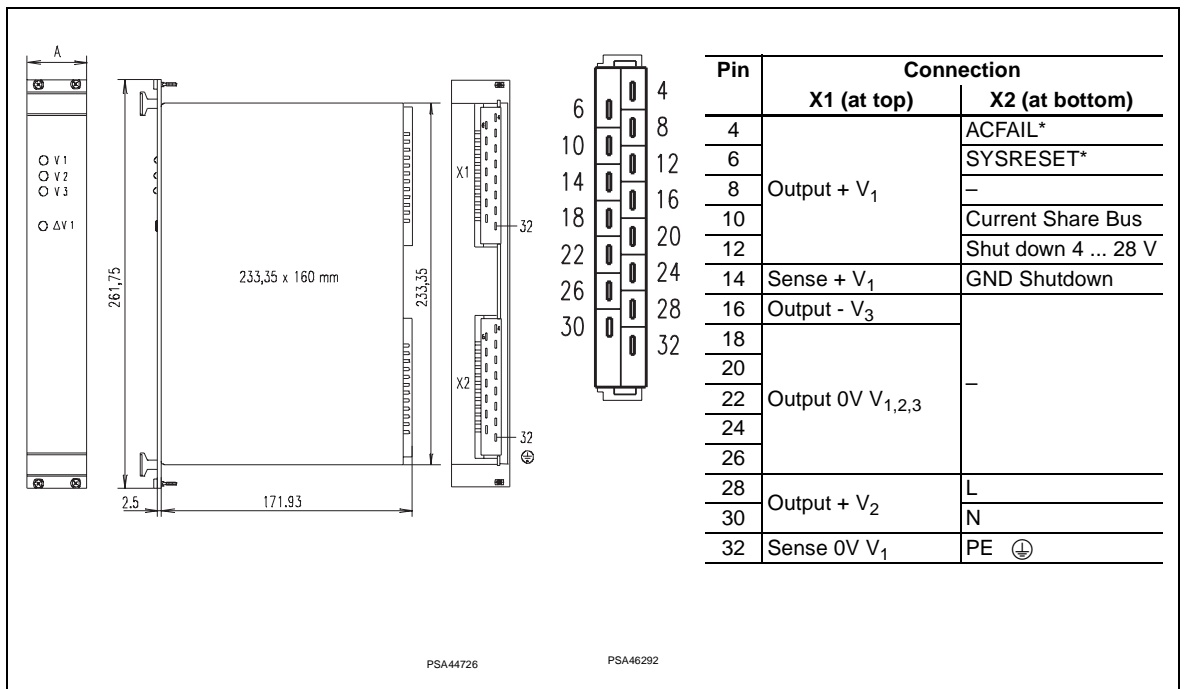

Output data at T _U = 0 ... 40 °C							Order No. incl. mounted EMC Front panel ¹⁾			
Voltage in V			Current in A			Power output in W total (V ₂ +V ₃)	Height in U	Width A in HP	Power supply Type	Mains voltage
V ₁	V ₂	V ₃	I ₁	I ₂	I ₃				90 – 264 V _{AC}	
+5	+12	-12	20	4,0	3,0	150 (60)	6	8	MPS 015	13100-205
+5	+12	-12	28	7,0	3,0	224 (84)		12	MPS 022	13100-203
+5	+15	-15	28	5,6	2,4	224 (84)		12	MPS 022/15	13100-204

¹⁾ Front panel: Front anodised, rear side chromated, slotted on both sides for mounting EMC contact strips in the event of increased EMC requirements (6 U EMC contact strips, Order No. 21101-707, 10 pieces)

Mating connector H15F (2× necessary) with FASTON connection, Order No. 69001-733

19" compatible AC/DC switched mode



Technical data

Input parameters						
Mains voltage (wide range input)	90 – 264 V _{AC} , 130 – 350 V _{AC}					
Mains nominal current at 90 V _{AC} /187 V _{AC}	MPS 015: 1.4 / 0.8 A, MPS 022: 1.9 / 1.2 A, MPS 022/15: 1.9/1.2 A					
Mains frequency range	47 – 63 Hz					
Power Factor Correction (PFC)	EN 61000-3-2					
Efficiency 115 V _{AC} /230 V _{AC}	70 % / 75 %					
Switch-on current at 230 V _{AC}	< 20 A					
Leakage current	≤ 500 µA					
Output parameters						
Output power at 40°C total unit/ auxiliary voltages V _{2,3}	MPS 015: 150 W / max. 60 W MPS 022: 224 W / max. 84 W					
Output voltage	metallically separated	V ₁	V ₂ , V ₃			
	factory set	5	+12	-12	+15	-15
	Adjustment range in V	4.5 ... 5.5	11.5 ... 13		13 ... 16	
Output current 0 ... 40°C	MPS 015 (UL values) in A	20 (18)	4 (3)	3 (2)	3.2 (2.4)	2.4 (1.6)
	MPS 022 (UL values) in A	28 (23)	7 (3.5)	3 (2)	5.6 (2.8)	2.4 (1.6)
Basic load	10 % × I _{1Nomin al}	–				
Current limitation	U/I curve					
Over-load protection	Permanently short-circuit protected					
Over-voltage protection shuts unit off, automatically resets	OVP, 6.25 V ± 10 %					
Remote sense compensated (+ V ₁)	< 0.5 V	–				
Residual ripple at	100 Hz	< 10 mV _{PP}				
	Clock-frequency	< 50 mV _{PP}				
Interference voltage (BW: 100 MHz)	< 100 mV _{PP}					
Load control, static (load change 0 – 100 %)	< 0.1 %	+12, +15 V: < ±1 % -12, -15 V: < ±1 %				
	Mains control at ± 15 % change in mains voltage	5 mV				
External OFF with 4–28 V _{DC} or switch	Connectors X2					
Output decoupled via diode	V ₁					

Dynamic control deviations		
(load change: 10 ... 100 % with 100 Hz; di/dt = 0.135 A/µs)		
Overall control time	< 0.5 ms	
Cross-control	< 0.1 % (V ₁), < 0.5 % (V _{2,3})	
Overshoot and undershoot amplitude	< 400 mV (V ₁), < 300 mV (V _{2,3})	
Other characteristics		
Mains fuse 115/230 V _{AC}	4 A/250 V, 5 × 20 mm, EN 60127-2/V	
Power failurebridging at V _{IN} = 93 V _{AC} and 100 % load	> 16 ms	
SYSRESET*, ACFAIL* signal	Active low, open collector, 48 mA/5 V	
Climatic test to	IEC 68-2-38	
Shock and vibration in accordance with acceleration of 2 g	EN 60068-2-6	
Weight (mass) MPS 015/ MPS 022	1.3 kg/2.4 kg	
Dimensions: Height 3 U/ width [HP]	MPS 015 – 8 HP MPS 022 – 12 HP	
CE (during the EMC measurements, the power supply was mounted in a case)	EMC interference-emission	EN 50081-1, EN 55011 Class B, EN 55022 Class B
	EMC interference-immunity, degree of severity 3	EN 50082-2, EN 61000-4-2, EN 61000-4-3, EN 61000-4-4, EN 61000-4-5, EN 61000-4-6,
	Safety, class of protection 1	EN 60950 (LGA)
Test voltage to EN 60950	Input-output	4.3 kV _{DC}
	Input PE	2.2 kV _{DC}
	Output PE	0.7 kV _{DC}
Safety	UL 1950	
Cooling	Convection	
Operation/storage ambient temperature	0 ... 70°C / -20 ... +85°C	
MTBF at full load, T _U = 40°C	330,000 h (UL value)	

AC/DC switched mode power supplies

Single, 50 W	3.11.2
Single, 80 W	3.11.4
Single, 100 W	3.11.6
Single, 130 W	3.11.8
Dual, 80 W	3.11.10
Dual, 100 W	3.11.12
Triple, 80 W	3.11.14
Triple, 100 W	3.11.16
Triple, 130 W	3.11.18
Triple, 150 / 224 W	3.11.20
Quad, 250 W	3.11.22
Quad, 350 W	3.11.24

AC/DC linear control systems

Single, 8 – 60 W ..	3.11.26
Dual, 10 – 58 W ...	3.11.28
Triple, 7 – 39 W ...	3.11.30

AC/DC non-regulated

Single, 84 W	3.11.32
Single, 240 W	3.11.34

DC/DC converters

Single, 20 to 120 W	3.11.36
Dual, 55 to 72 W ..	3.11.38
Triple, 64 to 70 W	3.11.40
Quad, 250 W	3.11.42
Quad, 350 W	3.11.44

Accessories

Mating connector female connector H 15 F	3.11.46
Keying/coding	3.11.47
Guide rails	3.11.47
Z-rails	3.11.47
EMC contact strips	3.11.48
Wall/horizontal rail installation	3.11.49

Schematic wiring diagram

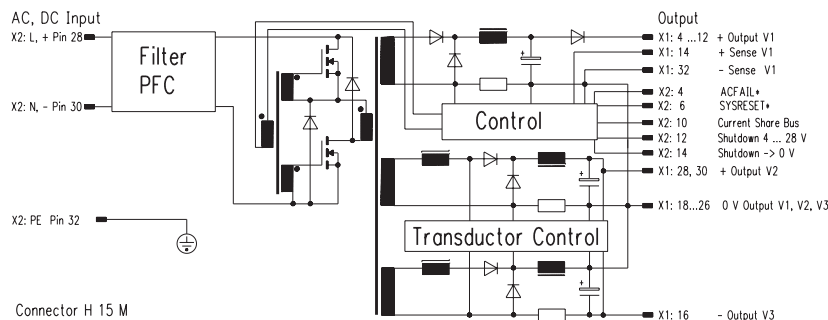



19" compatible AC/DC switched mode

Power supply units..... 3.10.0

19" compatible.....3.11.0

Open frame.....3.12.0

Power systems.....3.13.0

Uninterruptable power supplies (UPS)3.14.0

Backplanes/ test adapters .. 3.20.0

Microcomputer packaging systems (MPS) 3.30.0

Appendix..... 3.90.0



11300003

Quad, 250 W

maxpowerPRO

- 19" compatible AC/DC switched mode power supplies, pluggable 3 U, for compact PCI and other applications
- Wide range input voltage (90 – 264 V_{AC}, 48 V_{DC} see under DC/DC converters)
- Power factor correction (PFC) to EN 61000-3-2
- 4 output voltages
- Connectors P 47
- Outputs redundant with current share bus
- Hot swap
- Compact PCI signalling
- For industrial and telecommunications applications
- International approvals EN 60950, UL, cUL
- High reliability and long life

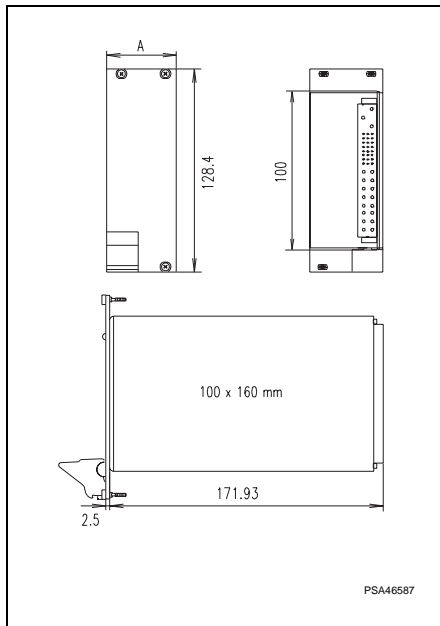

Output data at T _U = 0 ... 50 °C									Order No. (1 unit)			
Voltage				Current ¹⁾				Power output in W total (V ₁ + V ₂)	Height in U	Width A in HP	Power supply incl. mounted EMC Front panel ²⁾ Type	Mains voltage 90 – 254 V _{AC}
V ₁	V ₂	V ₃	V ₄	I ₁	I ₂	I ₃	I ₄					
5	3.3	+12	-12	25	25	5	1.5	250 (150)	3	8	CPCI 250	13100-141

¹⁾ with forced cooling in the system from 2 m/s

²⁾ Front panel: Front anodised, rear side chromated, slotted on both sides for mounting EMC contact strips in the event of increased EMC requirements, IEL handle (3 U EMC contact strips, Order No. 21101-853, 10 pieces)

Accessories

Mating connector/intermediate plate 3 U,
Order No. 23098-104

19" compatible AC/DC switched mode



Technical data

Input parameters					
Mains-voltage (wide range input)	Nominal values V_{AC}	100 – 240 V_{AC}			
	Operating-ranges	90 – 254 V_{AC}			
Mains nominal current 115 V_{AC} /220 V_{AC}	3.2 A/1.6 A				
Mains frequency range	50 – 60 Hz				
Power factor correction in accordance with	EN 61000-3-2				
Efficiency type	> 70 %				
Switch-on current I_p (with 230 V_{AC})	< 20 A				
Output parameters					
Output power max.: Convection/forced cooling with 2 m/s	75 W/150 W		48 W/78 W		
Output voltage [V]	V_1	V_2	V_3	V_4	
	factory set	5 V	3.3 V	12 V	-12 V
	Tolerance	± 50 mV			
Output current [A] 0 ... 50 °C	Convection	15	15	3	1
	Cooling 2 m/s	25	25	5	1.5
	Derating 50 – 70 °C	2 %/K			
Overcurrent protection	all outputs at 120 %				
Residual ripple/interference voltage (bandwidth = BW)	50 mV _{PP} (BW: 20 MHz)		< 100 mV (BW: 20 MHz)		
Load control	+5 % -3 %		± 5 %		
Mains control, static	1 %				
Cross-control	1 %				
Temperature coefficient	-0.02 %/K (0 – 50 °C)				
Connectors, offset 2.54 mm	Positronic P47				
Dynamic control deviations (load change: 50 ... 100 % with 100 Hz; dI/dt = 0.25 A/μs)					
Control time at $0.01 \times V_{1 \text{ Nominal}}$	< 1.5 ms				
Overshoot and undershoot amplitude	< 5 %				

Protection and monitoring facilities		
Switch-on time	< 4 s	
Mains fuse internal	6.3 A/250 V_{AC} , 5 × 20 mm, DIN 41571	
Power failure bridging at 90 V_{AC} and 100 % load	20 ms	
Switch power supply on/off externally	"INH" = Inhibit ("EN" = Enable) normal high, drive low (high) to turn off (on) (max. 15 V/150 μA)	
Over-voltage protection OVP shuts power supply off, restart	120 – 130 % at $V_{1,2}$	
Remote sense compensated per line	Max. 0.25 V	
Current share with one cable connection	V_1, V_2, V_3 , "ISH" signal, tolerance ± 10 %	
Power failure signalling	TTL signal, active high	
"DEG" signal if temperature outside of range (option)	"HIGH" < 50 °C; "LOW" > 50 °C, tolerance ± 5 %	
Power down "FAIL" signal at 70 °C, automatic restart (option)	"HIGH" < 70 °C; "LOW" > 70 °C, tolerance ± 5 %	
Two-color LED, fault/OK status	red/green	
Test and environmental conditions		
Climatic test to	IEC 68-2-38	
Shock and vibration in accordance with acceleration of 2 g	EN 60068-2-6	
Height 3 U/depth 160 mm	Width 8 HP	
Weight (mass)	2 kg	
CE	Interference emission	CISPR22 Class B, EN 50081-1, EN 55011 Class B,
	Interference immunity, degree of severity 3	EN 50082-2, EN 61000-4-2, EN 61000-4-3, EN 61000-4-4, EN 61000-4-5, EN 61000-4-6,
	Safety, class of protection 1	EN 60950
High voltage test to EN 60950	Input-output	4.3 kV _{DC}
	Input PE	2.2 kV _{DC}
Safety	UL 1950, cUL, TÜV & CE (applied for)	
Power supply maintenance-free	Yes	
Necessary cooling for the power supply	2 m/s	
Operation/storage ambient temperature	10 ... 70 °C / -40 ... +85 °C	
Relative humidity, non-condensing	20 % – 95 %	
MTBF	200,000 h (50 °C)	

AC/DC switched mode power supplies

Single, 50 W	3.11.2
Single, 80 W	3.11.4
Single, 100 W	3.11.6
Single, 130 W	3.11.8
Dual, 80 W	3.11.10
Dual, 100 W	3.11.12
Triple, 80 W	3.11.14
Triple, 100 W	3.11.16
Triple, 130 W	3.11.18
Triple, 150 / 224 W	3.11.20
Quad, 250 W	3.11.22
Quad, 350 W	3.11.24

AC/DC linear control systems

Single, 8 – 60 W ..	3.11.26
Dual, 10 – 58 W ...	3.11.28
Triple, 7 – 39 W ...	3.11.30

AC/DC non-regulated

Single, 84 W	3.11.32
Single, 240 W	3.11.34

DC/DC converters

Single, 20 to 120 W	3.11.36
Dual, 55 to 72 W ..	3.11.38
Triple, 64 to 70 W	3.11.40
Quad, 250 W	3.11.42
Quad, 350 W	3.11.44

Accessories

Mating connector female connector H 15 F	3.11.46
Keying/coding	3.11.47
Guide rails	3.11.47
Z-rails	3.11.47
EMC contact strips	3.11.48
Wall/horizontal rail installation	3.11.49



19" compatible AC/DC switched mode

Power supply units..... 3.10.0

19" compatible.....3.11.0

Open frame.....3.12.0

Power systems.....3.13.0

Uninterruptable power supplies (UPS)3.14.0

Backplanes/ test adapters .. 3.20.0

Microcomputer packaging systems (MPS) 3.30.0

Appendix..... 3.90.0



11300009

Quad, 350 W

maxpowerPRO

- 19" compatible AC/DC switched mode power supplies, pluggable 6 U, for compact PCI and other applications
- Wide range input voltage (90 – 264 V_{AC})
- Power factor correction (PFC) to EN 61000-3-2
- 4 output voltages
- Connectors P 47
- Redundancy operation with current share bus
- Hot swap
- Compact PCI signalling
- For industrial applications
- International approvals EN 60950, UL
- High reliability and long life

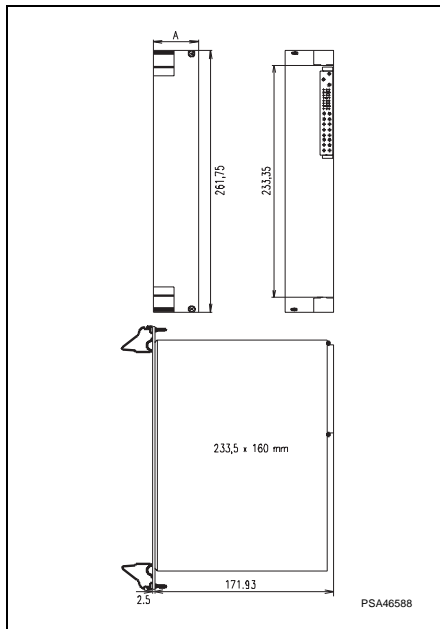

Output data at T _U = 0 ... 50 °C										Order No. incl. mounted EMC front panel ¹⁾			
Voltage in V				Current in A				Power output in W total ²⁾	Height in U	Width A in HP	Power supply Type	Mains voltage 90 – 254 V _{AC}	
V ₁	V ₂	V ₃	V ₄	I ₁	I ₂	I ₃	I ₄						
5	3.3	+12	-12	30	45	12	3	350	6	8	PCI 3-4	11098-141	

¹⁾ Front side anodised, rear side chromated, slotted on both sides incl. EMC contact strips in the event of increased EMC requirements, two IEL handles (6 U EMC contact strips, Order No. 21101-856, 10 pieces)

²⁾ Forced cooling, total capacity V₁ + V₂ = 200 W

Accessories

A 3 U backplane is required for interconnection between power supply and backplane. For assembly into a 6 U system, we offer other solutions - available upon request.

Description see backplanes - Power Bus 3 U, 1 piece, **Order No. 23098-105**

19" compatible AC/DC switched mode



Technical data

Input parameters				
Mains-voltage (wide range input)	Nominal values	100 – 240 V _{AC}		
	Operating-ranges	90 – 264 V _{AC}		
Mains frequency range	47 – 63 Hz			
Power factor correction in accordance with	EN 61000-3-2			
Efficiency type	74 %			
Switch-on current I _P 115/ 230 V	18/36 A			
Output parameters				
Output power max.	350 W			
Output voltages [V]	V ₁	V ₂	V ₃	V ₄
	5 V	3.3 V	12 V	-12 V
Output currents 0 ... 50 °C [A]	30	45	12/15	3
	Residual ripple/interference voltage			
				1 % or 100 mV
Load control with/without sense	0.5 % / 2 %			
Overshoot	1 % switch on/switch off 3 % load change 50 – 100 %			
Mains control, static	0.1 %			
Power failure bridging at 100 % load	20 ms			
Temperature coefficient	0.02 %/K			
Connection connectors	DIN M24/8			
Basic load	not necessary			

Protection and monitoring facilities		
Switch-on time	< 4 s	
Mains fuse internal	10 A/250 V _{AC}	
Switch power supply on/off externally	Inhibit (enable) normal high, drive low (high) to turn off (on)	
Over-voltage protection (OVP)	all outputs 125 % of the mains voltage; reset via off/on or inhibit/enable	
Over-temperature protection	Automatic shut-off with automatic return	
Overcurrent protection	All outputs 105 – 125 % auto recovery	
Remote sense compensated per line	V ₁ , V ₂ , max. 0.5 V	
Current share	V ₁ , V ₂ , V ₃	
Power failure signal	TTL signal, active high	
Temperature outside of range signal	TTL signal, active high	
Two-color LED, fault/OK status	red/green	
Test and environmental conditions		
Climatic test to	IEC 68-2-38	
Shock and vibration in accordance with	EN 60068-2-6	
Height 6 U/depth 160 mm	Width 8 HP	
Weight (mass)	2.3 kg	
CE	Interference emission	FCC Part 15, EN 55022
	Interference immunity	EN 50082-1, EN 61000-4-2, EN 61000-4-4, EN 61000-4-5, EN 61000-3-2, EN 61000-3-3
	Safety, class of protection 1	EN 60950
High voltage test to EN 60950	Input-output	4.3 kV _{DC}
	Input PE	2.2 kV _{DC}
Safety	UL, cUL, TÜV & CE	
Power supply maintenance-free	Yes	
Necessary cooling for the power supply	400 lfm, forced	
Operation/storage ambient temperature	0 ... 50°C / -40 ... +85°C	
Relative humidity, non-condensing	95 %	
MTBF at 25 °C	250,000 h (Bellcore STD.)	

AC/DC switched mode power supplies

Single, 50 W	3.11.2
Single, 80 W	3.11.4
Single, 100 W	3.11.6
Single, 130 W	3.11.8
Dual, 80 W	3.11.10
Dual, 100 W	3.11.12
Triple, 80 W	3.11.14
Triple, 100 W	3.11.16
Triple, 130 W	3.11.18
Triple, 150 / 224 W	3.11.20
Quad, 250 W	3.11.22
Quad, 350 W	3.11.24

AC/DC linear control systems

Single, 8 – 60 W ..	3.11.26
Dual, 10 – 58 W ...	3.11.28
Triple, 7 – 39 W ...	3.11.30

AC/DC non-regulated

Single, 84 W	3.11.32
Single, 240 W	3.11.34

DC/DC converters

Single, 20 to 120 W	3.11.36
Dual, 55 to 72 W ..	3.11.38
Triple, 64 to 70 W	3.11.40
Quad, 250 W	3.11.42
Quad, 350 W	3.11.44

Accessories

Mating connector female connector H 15 F	3.11.46
Keying/coding	3.11.47
Guide rails	3.11.47
Z-rails	3.11.47
EMC contact strips	3.11.48
Wall/horizontal rail installation	3.11.49



19" compatible AC/DC linear control systems

Power supply units..... 3.10.0

19" compatible.....3.11.0

Open frame.....3.12.0

Power systems.....3.13.0

Uninterruptable power supplies (UPS)3.14.0

Backplanes/ test adapters .. 3.20.0

Microcomputer packaging systems (MPS) 3.30.0

Appendix..... 3.90.0

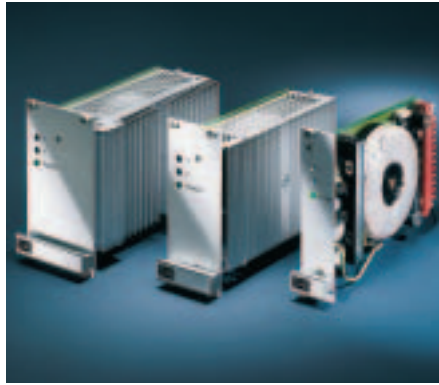

11397001



Single, 8 - 60 W

- 19" compatible AC/DC power supply, pluggable 3 U
- Mains input voltage 230 V_{AC} (can be converted to 115 V_{AC} with conversion kit, see below)
- 1 output voltage
- High control accuracy
- Low residual ripple and very low-interference
- Suitable for medical applications (8 mm safety clearances)
- High reliability and long life
- PSM, PSG
 - Output voltage can be externally remote controlled (1 ... 10 V)
 - Conversion of the control curve for sensitive loads (U/I - Fold Back)
 - Current measurement via shunt

100 x 160 mm

171.93

128.4

100

32

2.5

DUM0084

PSA46292

Pin	PSK single	PSM, PSG single
4	Sense + V ₁	Sense + V ₁
6	Output + V ₁	Output + V ₁
8	Output 0V V ₁	Output 0V V ₁
10	Sense 0V V ₁	Sense 0V V ₁
12		Optional: Redundancy diode
14		External on/off
16		GND
18		V remote input + V _C
20		V-shunt + V _S
22		V-shunt - V _S
24		-
26		-
28	L	L
30	N	N
32	PE ⊕	PE ⊕

Note

The front panel is not included in delivery.

Voltage in V	Output data at T _U = 0 ... 50 °C			Power supply Type	Order No. (1 unit) ¹⁾	
	Current in A	Power output in W	Width A in HP		Mains voltage ⁴⁾ 230 V _{AC}	Front panel ²⁾ EMC anodised
5	1.5	8	6	PSK 105 ³⁾	13105-001	21005-475
	4.0	20	10	PSM 105	13105-006	21005-473
	6.0	30	14	PSG 105	13105-011	21005-474
12	1.1	13	6	PSK 112 ³⁾	13105-002	21005-475
	2.8	31	10	PSM 112	13105-007	21005-473
	4.2	50	14	PSG 112	13105-012	21005-474
15	1.0	15	6	PSK 115 ³⁾	13105-003	21005-475
	2.2	33	10	PSM 115	13105-008	21005-473
	3.5	53	14	PSG 115	13105-013	21005-474
24	0.6	16	6	PSK 124 ³⁾	13105-004	21005-475
	1.5	36	10	PSM 124	13105-009	21005-473
	2.5	60	14	PSG 124	13105-014	21005-474

¹⁾ Please order front panel and other accessories separately

²⁾ Front anodised, rear side chromated, slotted on both sides for mounting EMC contact strips in the event of increased EMC requirements
(3 U EMC contact strips, Order No. 21101-705, 10 pieces)

³⁾ Without case

⁴⁾ Mains voltage conversion kit 230 V to 115 V (Order No. 43105-999)

Mating connector H15F with FASTON connection, Order No. 69001-733

19" compatible AC/DC linear control systems



Technical data

Input parameters					
Mains voltage (with conversion kit)	Nominal values V_{IN} (operating ranges)	115 (103.5 ... 126.5) V_{AC} 230 (207 ... 253) V_{AC}			
Mains nominal current at 230 V_{AC}		PSK 0.16 A, PSM 0.36 A, PSG 0.45 A			
Mains frequency range		48 – 62 Hz			
Mains input current in accordance with		EN 61000-3-2 + A14			
Efficiency type		40 ... 65 %			
Current at switch-on		< 15 A (PSK < 3 A)			
Discharge current		< 50 μ A			
Output parameters					
Output voltage (potentiometer V at front)	factory set	5	12	15	24
	Adjustment range [V]	4.75 ... 5.25	11.5 ... 12.5	13.5 ... 15.5	23 ... 25.0
Output current at 50 °C (70 °C), max. current can be adjusted with front potentiometer C (50 ... 150 %)	PSK [A]	1.5 (0.9)	1.1 (0.7)	1.0 (0.6)	0.6 (0.4)
	PSM [A]	4.0 (2.4)	2.8 (1.7)	2.2 (1.3)	1.5 (0.9)
	PSG [A]	6.0 (3.7)	4.2 (2.5)	3.5 (2.0)	2.5 (1.5)
Derating from 50 to 70 °C		2 %/K			
Residual ripple		\leq 2 mV			
Load control, static ($I_L = 0 \dots I_{1Nominal}$)		< 0.01 %			
Mains control at \pm 10 % change in mains voltage		< 0.01 %			
Overall control time, tolerance 0.1 % $\times V_{1Nominal}$, load change 0 ... 100 % $di/dt = 0.135$ A/ μ s		\leq 50 μ s			
Temperature coefficient		0.01 %/K			
Output can be externally shut off with voltage		4 ... 24 $V_{DC} \rightarrow$ GND			
Output can be switched in series and in parallel (optionally with diode for redundancy operation)		Yes (PSM, PSG)			
Output can be remote controlled		1 ... 10 V ~ 0.1 ... 1 $\times V_{Nominal}$ (PSM, PSG)			
Measurement resistance (shunt) corresponds to		~ 10 mV/A (PSM, PSG)			

Protection and monitoring facilities		
Power failure bridging at 100 % load		$V_{IN} = 207$ V, PSK > 10 ms, PSM > 7 ms, PSG > 6 ms $V_{IN} = 230$ V, PSK > 16 ms, PSM > 10 ms, PSG > 8 ms
Current limitation		Yes
Over-load protection, short-circuit current controlled max.		I_1 Nom. + 15 %
Over-voltage protection OVP (shuts power supply off), automatic response value approx.		$V_1 + 20$ %
Over-temperature protection of the series pass transistor		Yes
Remote sense compensated per line (with $V_{1Nominal}$)		Max. 0.5 V
Air and creepage distance Primary-secondary side/ Primary PE		\geq 8 mm / \geq 4 mm
Output voltage present, LED green		LED POWER
Other characteristics		
Climatic test to		IEC 68-2-38
Shock and vibration		EN 60068-2-6
Dimensions: Height 3 U		Width: PSK 6 HP, PSM 10 HP, PSG 14 HP
Weight (mass)		PSK 0.8 kg, PSM 1.6 kg, PSG 1.9 kg
CE	EMC interference-emission	EN 50081-1, EN 55011 Class B, EN 55022 Class B
	EMC interference-immunity, degree of severity 3	EN 50082-2, EN 61000-4-2, EN 61000-4-3, EN 61000-4-4, EN 61000-4-5
	Safety, class of protection 1	EN 60950 (LGA for PSK, PSM, PSG) EN 60601-1 (PSK)
Test voltage to EN 60950	Input-output	4.3 kV _{DC}
	Input PE	2.2 kV _{DC}
	Output PE	0.7 kV _{DC}
Toroidal transformer (low emission)		EN 60742
Power supply maintenance-free		Yes
Cooling		Convection
Operation/storage ambient temperature		0 ... 70 °C / -20 ... +85 °C
Relative humidity, non-condensing (operation/storage)		30 ... 80 % / 10 ... 95 %
MTBF at full load, $T_U = 40$ °C		PSK 1,100,000 h PSM/PSG 730,000 h

AC/DC switched mode power supplies

Single, 50 W	3.11.2
Single, 80 W	3.11.4
Single, 100 W	3.11.6
Single, 130 W	3.11.8
Dual, 80 W	3.11.10
Dual, 100 W	3.11.12
Triple, 80 W	3.11.14
Triple, 100 W	3.11.16
Triple, 130 W	3.11.18
Triple, 150 / 224 W	3.11.20
Quad, 250 W	3.11.22
Quad, 350 W	3.11.24

AC/DC linear control systems

Single, 8 – 60 W ..	3.11.26
Dual, 10 – 58 W ...	3.11.28
Triple, 7 – 39 W ...	3.11.30

AC/DC non-regulated

Single, 84 W	3.11.32
Single, 240 W	3.11.34

DC/DC converters

Single, 20 to 120 W	3.11.36
Dual, 55 to 72 W ..	3.11.38
Triple, 64 to 70 W	3.11.40
Quad, 250 W	3.11.42
Quad, 350 W	3.11.44

Accessories

Mating connector female connector H 15 F	3.11.46
Keying/coding	3.11.47
Guide rails	3.11.47
Z-rails	3.11.47
EMC contact strips	3.11.48
Wall/horizontal rail installation	3.11.49

Schematic wiring diagram

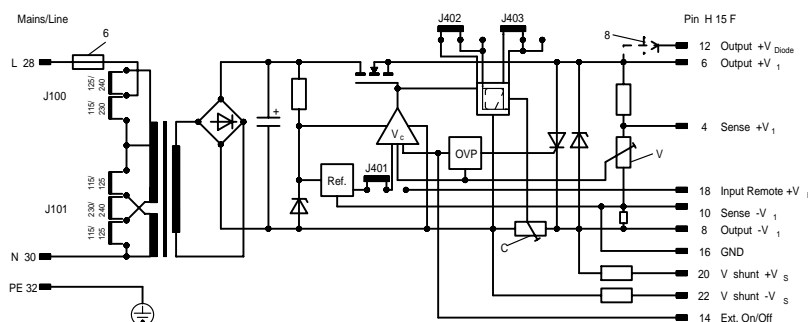

MPA45030



19" compatible AC/DC linear control systems

Power supply units..... 3.10.0

19" compatible.....3.11.0

Open frame.....3.12.0

Power systems.....3.13.0

Uninterruptable power supplies (UPS)3.14.0

Backplanes/ test adapters .. 3.20.0

Microcomputer packaging systems (MPS) 3.30.0

Appendix..... 3.90.0



11300001

Dual, 10 – 58 W

- 19" compatible AC/DC power supply, pluggable 3 U
- Mains input voltage 230 V_{AC} (can be converted to 115 V_{AC} with conversion kit, see below)
- 2 output voltages (galvanically separated)
- High control accuracy
- Low residual ripple and very low-interference
- Suitable for medical applications (8 mm safety clearances)
- High reliability and long life



Pin	Male connector H15
4	Sense + V ₁
6	Output + V ₁
8	Output 0V V ₁
10	Sense 0V V ₁
12	Sense + V ₂
14	Output + V ₂
16	Output 0V V ₂
18	Sense 0V V ₂
20	
22	
24	-
26	
28	L
30	N
32	PE ⊕

Note

Outputs metalically separated. The front panel is not included in delivery.

Output data at T _J = 0 ... 50 °C						Order No. ¹⁾		
Voltage in V		Current in A		Power output in W	Width A in HP	Power supply Type	Mains voltage ⁴⁾ 230 V _{AC}	Front panel ²⁾ EMC
V ₁	V ₂	I ₁	I ₂					
5	5	1.4	1.4	14	10	PSM 205	13105-021	21005-477
		0.4	0.4	10	6	PSK 212 ³⁾	13105-017	21005-476
12	12	1.0	1.0	24	10	PSM 212	13105-022	21005-477
		1.5	1.5	36	14	PSG 212	13105-027	21005-478
15	15	0.4	0.4	12	6	PSK 215 ³⁾	13105-018	21005-476
		1.0	1.0	30	10	PSM 215	13105-023	21005-477
		1.5	1.5	45	14	PSG 215	13105-028	21005-478
24	24	1.2	1.2	58	14	PSG 224	13105-029	21005-478

¹⁾ Please order front panel and other accessories separately

²⁾ Front anodised, rear side chromated, slotted on both sides for mounting EMC contact strips in the event of increased EMC requirements
(3 U EMC contact strips, Order No. 21101-705, 10 pieces)

³⁾ Without case

⁴⁾ Mains voltage conversion kit 230 V to 115 V (Order No. 43105-999)

Mating connector H15F with FASTON connection, Order No. 69001-733

19" compatible AC/DC linear control systems



Technical data

Input parameters		Output parameters		
Mains voltage (with conversion kit)	Nominal values V_{IN} (operating ranges)	115 (103.5 ... 126.5) V_{AC} 230 (207 ... 253) V_{AC}		
Mains nominal current at 230 V_{AC}		PSK 0.16 A, PSM 0.35 A, PSG 0.45 A		
Mains frequency range		48 – 62 Hz		
Mains input current in accordance with		EN 61000-3-2 + A14		
Efficiency type		40 ... 60 %		
Current at switch-on		< 15 A (PSK < 3 A)		
Discharge current		< 50 μ A		
Output parameters		$V_{1,2}$		
Output voltage (potentiometer $V_{1,2}$ at front)	factory set	12	15	24
	Adjustment range [V]	11.5 ... 12.5	13.5 ... 15.5	23 ... 25.0
Output current at 50 °C (70 °C), max. current can be adjusted with front potentiometer $C_{1,2}$ (50 ... 150 %)	PSK [A]	0.4 (0.2)	0.4 (0.2)	0.3 (0.15)
	PSM [A]	1.0 (0.6)	1.0 (0.6)	0.6 (0.4)
	PSG [A]	1.5 (0.9)	1.5 (0.9)	1.2 (0.8)
Derating from 50 to 70 °C approx.		2 %/K		
Residual ripple		\leq 2 mV		
Load control, static ($I_{1,2} = 0 \dots I_{1,2 \text{ Nominal}}$)		< 0.01 %		
Mains control at \pm 10 % change in mains voltage		< 0.01 %		
Overall control time, tolerance 0.1 % $\times V_{1/2 \text{ Nominal}}$ load change 0 ... 100 % $di/dt = 0.135 \text{ A}/\mu\text{s}$		\leq 50 μs		
Temperature coefficient		0.01 %/K		
Output can be switched in series and in parallel		Yes		

Protection and monitoring facilities

Power failure bridging at 100 % load	$V_{IN} = 207 \text{ V}$, PSK > 10 ms, PSM > 7 ms, PSG > 6 ms $V_{IN} = 230 \text{ V}$, PSK > 16 ms, PSM > 10 ms, PSG > 8 ms	
Current limitation	Constant current	
Over-load protection, short-circuit current controlled max.	$I_{1/2 \text{ Nominal}} + 15 \%$	
Over-voltage protection OVP (shuts power supply off), automatic response value approx.	$V_{1/2} + 20 \%$	–
Over-temperature protection of the series pass transistors	Yes	
Remote sense compensated per line (with $V_{1/2 \text{ Nominal}}$)	Max. 0.5 V	
Air and creepage distance Primary-secondary side/ Primary PE	\geq 8 mm / \geq 4 mm	
Output voltage present, LED green	LED POWER	

Test and environmental conditions

Test voltage to EN 60950	Input-output	4.3 kV_{DC}
	Input PE	2.2 kV_{DC}
	Output PE	0.7 kV_{DC}
Climatic test to	IEC 68-2-38	
Shock and vibration in accordance with (acceleration of 2 g)	EN 60068-2-6	
Dimensions: Height 3 U	Width: PSK 6 HP, PSM 10 HP, PSG 14 HP	
Weight (mass)	PSK 0.8 kg, PSM 1.6 kg, PSG 1.9 kg	
Electromagnetic compatibility CE	Interference-emission	EN 50081-1, EN 55011 Class B, EN 55022 Class B
	Interference-immunity, degree of severity 3	EN 50082-2, EN 61000-4-2, EN 61000-4-3, EN 61000-4-4, EN 61000-4-5
	Safety, class of protection 1	EN 60950 (PSM, PSG) EN 60601-1 (PSM, PSG)
Toroidal transformer (low emission) to	EN 60742	
Power supply maintenance-free	Yes	
Cooling	Convection	
Operation/storage ambient temperature	0 ... 70 °C / -20 ... +85 °C	
Relative humidity, non-condensing (operation/storage)	30 ... 80 % / 10 ... 95 %	
MTBF at full load, $T_U = 40 \text{ °C}$	PSK 960.000 h PSM / PSG 580.000 h	

AC/DC switched mode power supplies

Single, 50 W	3.11.2
Single, 80 W	3.11.4
Single, 100 W	3.11.6
Single, 130 W	3.11.8
Dual, 80 W	3.11.10
Dual, 100 W	3.11.12
Triple, 80 W	3.11.14
Triple, 100 W	3.11.16
Triple, 130 W	3.11.18
Triple, 150 / 224 W	3.11.20
Quad, 250 W	3.11.22
Quad, 350 W	3.11.24

AC/DC linear control systems

Single, 8 – 60 W ..	3.11.26
Dual, 10 – 58 W ...	3.11.28
Triple, 7 – 39 W ...	3.11.30

AC/DC non-regulated

Single, 84 W	3.11.32
Single, 240 W	3.11.34

DC/DC converters

Single, 20 to 120 W	3.11.36
Dual, 55 to 72 W ..	3.11.38
Triple, 64 to 70 W	3.11.40
Quad, 250 W	3.11.42
Quad, 350 W	3.11.44

Accessories

Mating connector female connector H 15 F	3.11.46
Keying/coding	3.11.47
Guide rails	3.11.47
Z-rails	3.11.47
EMC contact strips	3.11.48
Wall/horizontal rail installation	3.11.49

Schematic wiring diagram

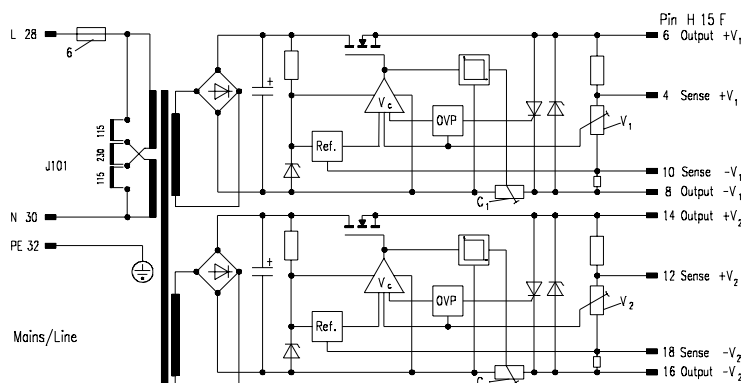

DIA45096



19" compatible AC/DC linear control systems

Power supply units..... 3.10.0

19" compatible.....3.11.0

Open frame.....3.12.0

Power systems.....3.13.0

Uninterruptable power supplies (UPS)3.14.0

Backplanes/ test adapters .. 3.20.0

Microcomputer packaging systems (MPS) 3.30.0

Appendix..... 3.90.0



11300002

Triple, 7 - 39 W

- 19" compatible AC/DC power supply, pluggable 3 U
- Mains input voltage 230 V_{AC} (can be converted to 115 V_{AC} with conversion kit, see below)
- 3 output voltages (galvanically separated)
- High control accuracy
- Low residual ripple and very low-interference
- Suitable for medical applications (8 mm safety clearances)
- High reliability and long life



100 x 160 mm

DUM0084

PSA46292

Pin	Connection
4	Sense + V ₁ (PSM, PSG)
6	Output + V ₁
8	Output 0V V ₁
10	Sense 0V V ₁ (PSM, PSG)
12	Output + V ₂
14	Output - V ₂
16	Output + V ₃
18	Output - V ₃
20	Data save
22	Power failure
24	0 V for pin 20, 22
26	-
28	L
30	N
32	PE ⊕

Note

The front panel is not included in delivery.

Output data at T _U = 0 ... 50 °C								Order No. (1 unit) ¹⁾		
Voltage in V			Current in A			Power output in W	Width in HP	Power supply Type	Mains voltage ⁴⁾ 230 V _{AC}	Front panel ²⁾ EMC anodised
V ₁	V ₂	V ₃	I ₁	I ₂	I ₃					
5	12	12	0.5	0.2	0.2	8	6	PSK 312 ³⁾	13105-051	21005-470
			1.5	0.5	0.5	20	10	PSM 312	13105-052	21005-451
			3.0	1.0	1.0	39	14	PSG 312	13105-053	21005-439

¹⁾ Please order front panel and other accessories separately

²⁾ Front anodised, rear side chromated, slotted on both sides for mounting EMC contact strips in the event of increased EMC requirements
(3 U EMC contact strips, Order No. 21101-705, 10 pieces)

³⁾ Without case

⁴⁾ Mains voltage conversion kit 230 V to 115 V (Order No. 43105-999)

Mating connector H15F with FASTON connection, Order No. 69001-733

19" compatible AC/DC linear control systems



Technical data

Input parameters			
Mains voltage (with conversion kit)	Nominal values V_{IN} (operating-ranges)	115 V _{AC} (103.5 ... 126.5) 230 V _{AC} (207 ... 253)	
Mains nominal current at 230 V _{AC}		PSK 0.11 A, PSM 0.3 A, PSG 0.4 A	
Mains frequency range		48 – 62 Hz	
Mains input current in accordance with		EN 61000-3-2 + A14	
Efficiency type		PSK 40 ... 46 %, PSM, PSG 45 ... 52 %	
Current at switch-on		< 15 A (PSK < 2 A)	
Discharge current		< 50 µA	
Output parameters			
		V_1	$V_{2,3}$
Output voltage (potentiometer $V_{1,2,3}$ at front)	factory set	5 V	12 V, 15 V
	Adjustment-range	4.755.25 ... V	12 ... 15.5 V
Output current at 50 °C (70 °C)	PSK	0.5 (0.3) A	0.2 (0.1) A
	PSM	1.5 (0.8) A	0.5 (0.3) A
	PSG	3 (1.5) A	1 (0.6) A
Load control, static ($I_1=0...I_1$ Nominal)	PSK	≤ 0.2 %	≤ 0.3 %
	PSM	≤ 0.01 %	≤ 1 %
	PSG	≤ 0.01 %	≤ 2 %
Residual ripple		≤ 2 mV	
Mains control at ± 10 % change in mains voltage		< 0.01 %	< 0.2 %
Overall control time, tolerance 0.1 % × $V_{1/2}$ Nominal, load change 0 ... 100 % $di/dt = 0.135$ A/µs		≤ 50 µs	
Temperature coefficient		0.05 %/K	
Remote sense (PSM, PSG) compensated		Max. 0.5 V	–

Protection and monitoring facilities

Power failure bridging at 100 % load	$V_{IN} = 207$ V, PSK, PSM > 10 ms, PSG > 7 ms, $V_{IN} = 230$ V, PSK, PSM > 15 ms, PSG > 12 ms
Over-voltage protection OVP for 5 V in the case of PSM and PSG	$V_{Nominal} + 20$ %
Current limitation	Constant current
Over-load protection, short-circuit current controlled max.	I_1 type: PSK: $I_{nom.} + 20$ %, PSM/PSG: $I_{nom.} + 50$ %, $I_{2,3}$ type: 2 A
Over-temperature protection of the series pass transistor	Yes
Air and creepage distance Primary-secondary side/ Primary PE	≥ 8 mm / ≥ 4 mm
Power failure signals	Power failure, save data: Active low, open collector
Output voltage present, LED green	LED POWER V_1, V_2, V_3

Test and environmental conditions

Climatic test to	IEC 68-2-38	
Shock and vibration in accordance with (acceleration of 2 g)	EN 60068-2-6	
Dimensions: Height 3 U	Width: PSK 6 HP, PSM 10 HP, PSG 14 HP	
Weight (mass)	PSK 0.8 kg, PSM 1.6 kg, PSG 1.9 kg	
CE	EMC interference-emission	EN 50081-1, EN 55011 Class B, EN 55022 Class B
	EMC interference-immunity, degree of severity 3	EN 50082-2, EN 61000-4-2, EN 61000-4-3, EN 61000-4-4, EN 61000-4-5
	Safety, class of protection 1	EN 60950
Test voltage to EN 60950	Input-output	4.3 kV _{DC}
	Input PE	2.2 kV _{DC}
	Output PE	0.7 kV _{DC}
	Output-output	0.7 kV _{DC}
Toroidal transformer (low emission) to	EN 60742	
Power supply maintenance-free	Yes	
Cooling	Convection	
Operation/storage ambient temperature	0 ... 70 °C / -20 ... +85 °C	
Relative humidity, non-condensing (operation/storage)	30 ... 80 % / 10 ... 95 %	
MTBF at full load, $T_U = 40$ °C	PSK 850,000 h PSM/PSG 470,000 h	

AC/DC switched mode power supplies

Single, 50 W	3.11.2
Single, 80 W	3.11.4
Single, 100 W	3.11.6
Single, 130 W	3.11.8
Dual, 80 W	3.11.10
Dual, 100 W	3.11.12
Triple, 80 W	3.11.14
Triple, 100 W	3.11.16
Triple, 130 W	3.11.18
Triple, 150 / 224 W	3.11.20
Quad, 250 W	3.11.22
Quad, 350 W	3.11.24

AC/DC linear control systems

Single, 8 – 60 W ..	3.11.26
Dual, 10 – 58 W ..	3.11.28
Triple, 7 – 39 W ..	3.11.30

AC/DC non-regulated

Single, 84 W	3.11.32
Single, 240 W	3.11.34

DC/DC converters

Single, 20 to 120 W	3.11.36
Dual, 55 to 72 W ..	3.11.38
Triple, 64 to 70 W	3.11.40
Quad, 250 W	3.11.42
Quad, 350 W	3.11.44

Accessories

Mating connector female connector H 15 F	3.11.46
Keying/coding	3.11.47
Guide rails	3.11.47
Z-rails	3.11.47
EMC contact strips	3.11.48
Wall/horizontal rail installation	3.11.49

Schematic wiring diagram

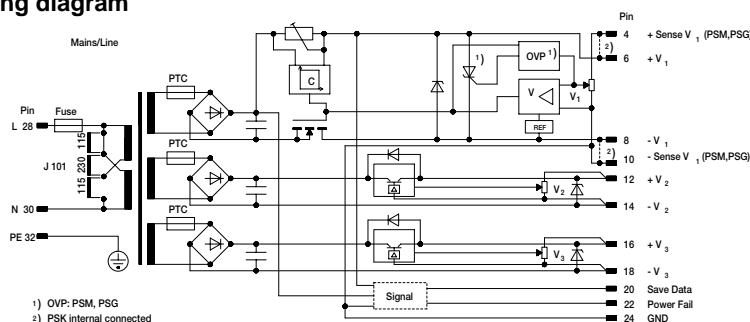



19" compatible AC/DC non-regulated

Power supply units..... 3.10.0
 19" compatible.....3.11.0
 Open frame.....3.12.0
 Power systems.....3.13.0
 Uninterruptable power supplies (UPS)3.14.0

Backplanes/
 test adapters .. 3.20.0

Microcomputer packaging systems (MPS) 3.30.0

Appendix..... 3.90.0



11396005

Single, 84 W

- 19" compatible AC/DC power supply, pluggable 3 U
- Mains input voltage 230 V_{AC} (can be converted to 115 V_{AC})
- 1 output voltage
- High reliability and long life



Pin	Connection
4	Output + V ₁
6	
8	
10	Output 0V V ₁
12	
14	
16	
18	-
20	
22	
24	
26	L
28	
30	
32	PE ⊕

Note

The front panel is not included in delivery.

Output data at T _U = 0 ... 50 °C				Order No. ¹⁾		
Voltage	Current	Power output	Width	Power supply	Mains voltage	Front panel ²⁾ EMC
in V	in A	in W	in HP	Type	230 V _{AC}	
24	3.5	84	14	PGG 124	11005-190	21005-472

¹⁾ Please order front panel and other accessories separately

²⁾ Front anodised, rear side chromated, slotted on both sides for mounting EMC contact strips in the event of increased EMC requirements
(3 U EMC contact strips, Order No. 21101-705, 10 pieces)

Mating connector H15F with FASTON connection, Order No. 69001-733

Other output voltages available on request

19" compatible AC/DC non-regulated



Technical data

Input parameters

Mains voltage (can be converted)	115/230 V _{AC} ± 10 %
Mains frequency range	48 – 62 Hz
Mains input current in accordance with	EN 61000-3-2 + A14

Output parameters

Output voltage (U _{max.})	24 V ± 10 %	
Output current (I _{max.})	3 A	
Residual ripple	See diagram	
Power failure bridging	U _{E Nominal}	Type 20 ms
	U _{E Nominal} - 10 %	Type 12 ms
Derating from 50 – 70 °C	2 %/K	

Other data

Test voltage to EN 60950	Input-output	4.3 kV _{DC}
	Input PE	2.2 kV _{DC}
	Output PE	0.7 kV _{DC}
Climatic test to	IEC 68-2-38	
Shock and vibration in accordance with acceleration of 2 g	EN 60068-2-6	
Suppression	VDE 0871 curve K	
Class of protection (VDE 0100)	Class 1	
Power supply maintenance-free	Yes	
Cooling	Convection	
Ambient temperature T _U	Operation	0 ... 70 °C
	Storage	-40 ... +85 °C

AC/DC switched mode power supplies

Single, 50 W	3.11.2
Single, 80 W	3.11.4
Single, 100 W	3.11.6
Single, 130 W	3.11.8
Dual, 80 W	3.11.10
Dual, 100 W	3.11.12
Triple, 80 W	3.11.14
Triple, 100 W	3.11.16
Triple, 130 W	3.11.18
Triple, 150 / 224 W	3.11.20
Quad, 250 W	3.11.22
Quad, 350 W	3.11.24

AC/DC linear control systems

Single, 8 – 60 W ..	3.11.26
Dual, 10 – 58 W ...	3.11.28
Triple, 7 – 39 W ...	3.11.30

AC/DC non-regulated

Single, 84 W	3.11.32
Single, 240 W	3.11.34

DC/DC converters

Single, 20 to 120 W	3.11.36
Dual, 55 to 72 W ..	3.11.38
Triple, 64 to 70 W	3.11.40
Quad, 250 W	3.11.42
Quad, 350 W	3.11.44

Accessories

Mating connector female connector H 15 F	3.11.46
Keying/coding	3.11.47
Guide rails	3.11.47
Z-rails	3.11.47
EMC contact strips	3.11.48
Wall/horizontal rail installation	3.11.49

Mains voltage switch-over

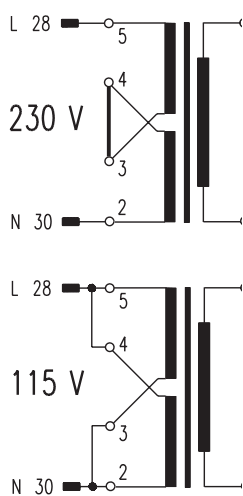

from DUM0047

Schematic wiring diagram

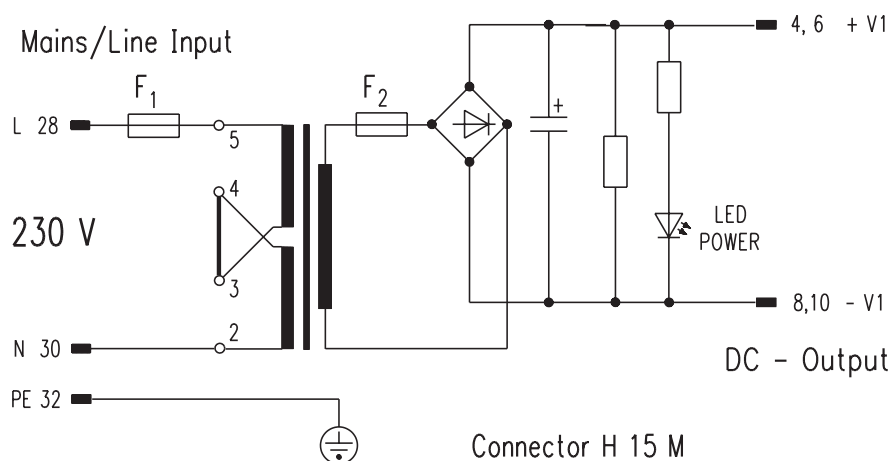

PSA46589



19" compatible AC/DC non-regulated

Power supply units..... 3.10.0

19" compatible.....3.11.0

Open frame.....3.12.0

Power systems.....3.13.0

Uninterruptable power supplies (UPS)3.14.0

Backplanes/ test adapters .. 3.20.0

Microcomputer packaging systems (MPS) 3.30.0

Appendix..... 3.90.0



11399012

Single, 240 W

- 19" compatible AC/DC power supply, pluggable 3 U
- Mains input voltage 230 V_{AC} (can be converted to 115 V_{AC})
- 1 output voltage
- Can be connected in series, parallel and redundancy operation
- Auxiliary voltage output (24 V/0.1 A) short-circuit protected, without galvanic separation
- Reset function (external on/off)
- High reliability and long life



Technical drawings showing dimensions: 128.4 mm height, 100 mm depth, 171.93 mm width, and 2.5 mm mounting hole offset. Reference numbers DJM0084 and PSA46292 are provided.

Pin	Connection
4	Output + V ₁
6	Output 0V V ₁
8	Output 0V V ₁
10	Output 0V V ₁
12	-
14	Reset, external on/off
16	-
18	Auxiliary voltage +V ₂
20	Auxiliary voltage -V ₂
22	-
24	-
26	-
28	L
30	N
32	PE ⊕

Note

The front panel is not included in delivery.

Output data at T _U = 0 ... 50 °C				Order No. (1 unit) ¹⁾		
Voltage	Current	Capacity	Width:	Power supply	Mains voltage	Front panel ²⁾ EMC
in V	in A	in W	in HP	Type	230 V _{AC}	
24	10	240	28	PUG 124	11005-262	21005-479

¹⁾ Please order front panel and other accessories separately

²⁾ Front anodised, rear side chromated, slotted on both sides for mounting EMC contact strips in the event of increased EMC requirements
(3 U EMC contact strips, Order No. 21101-705, 10 pieces)

Mating connector H15F with FASTON connection, Order No. 69001-733

Other output voltages available on request

19" compatible AC/DC non-regulated



Technical data

Input parameters		
Mainsvoltage (can be converted)	115/230 V _{AC} ± 10 %	
Mains frequency range	48 – 62 Hz	
Mains input current in accordance with	EN 61000-3-2 + A14	
Efficiency	78 %	
Mains nominal current at 230 V _{AC}	1.62 A	
Output parameters		
Output voltage	24 V ± 3 %	
Output current (I ₁ /I ₂)	10/0.1 A	
Residual ripple	< 2.4 V	
Auxiliary voltage	24 V, 0.1 A	
Power failure bridging	Type 9 ms, 12 ms at 0.8 × I _{nom}	
Other data		
Current limitation	Type 25 A	
Voltage clamping adjustable in idling mode	24 V, 0.1 A	
Over-temperature protection	Yes	
Test voltage to EN 60950	Input-output	4.3 kV _{DC}
	Input PE	2.2 kV _{DC}
	Output PE	0.7 kV _{DC}
Climatic test to	IEC 68-2-38	
Shock and vibration in accordance with acceleration of 2 g	EN 60068-2-6	
Safety to EN 60950	VDE No. 1641	
Suppression	VDE 0875, Part 3	
Class of protection (VDE 0100)	Class 1	
Power supply maintenance-free	Yes	
Cooling	Convection	
Ambient temperature T _U	Operation	0 ... 70°C
	Storage	-40 ... +85°C

AC/DC switched mode power supplies

Single, 50 W	3.11.2
Single, 80 W	3.11.4
Single, 100 W	3.11.6
Single, 130 W	3.11.8
Dual, 80 W	3.11.10
Dual, 100 W	3.11.12
Triple, 80 W	3.11.14
Triple, 100 W	3.11.16
Triple, 130 W	3.11.18
Triple, 150 / 224 W	3.11.20
Quad, 250 W	3.11.22
Quad, 350 W	3.11.24

AC/DC linear control systems

Single, 8 – 60 W ..	3.11.26
Dual, 10 – 58 W ...	3.11.28
Triple, 7 – 39 W ...	3.11.30

AC/DC non-regulated

Single, 84 W	3.11.32
Single, 240 W	3.11.34

DC/DC converters

Single, 20 to 120 W	3.11.36
Dual, 55 to 72 W ..	3.11.38
Triple, 64 to 70 W	3.11.40
Quad, 250 W	3.11.42
Quad, 350 W	3.11.44

Accessories

Mating connector female connector	
H 15 F	3.11.46
Keying/coding	3.11.47
Guide rails	3.11.47
Z-rails	3.11.47
EMC contact strips	3.11.48
Wall/horizontal rail installation	3.11.49

Load behaviour

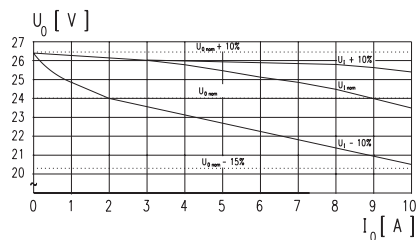

DJM0085

Mains voltage switch-over

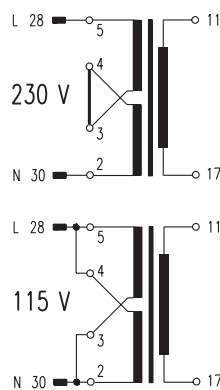

from DJM0047

Schematic wiring diagram

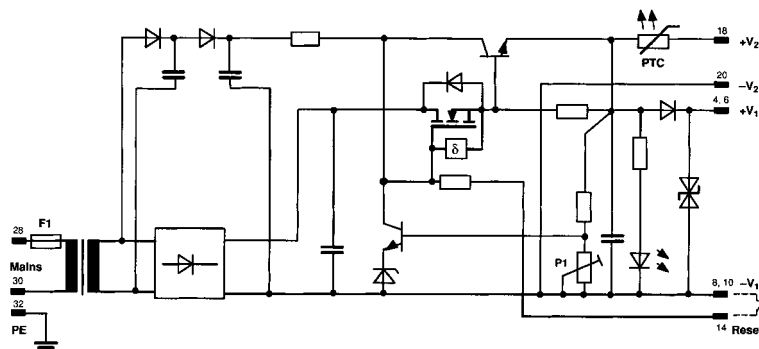

A4/783



19" compatible DC/DC converters

- Power supply units..... 3.10.0
- 19" compatible.....3.11.0**
- Open frame.....3.12.0
- Power systems.....3.13.0
- Uninterruptable power supplies (UPS)3.14.0

- Backplanes/ test adapters .. 3.20.0

- Microcomputer packaging systems (MPS) 3.30.0

- Appendix..... 3.90.0



11396008

Single, 20 to 120 W

- DC series
- Input voltage from 9 to 160 V_{DC} (4 ranges)
- 19" compatible DC/DC switched mode power supplies (3 U)
- 1 output voltage
- Galvanic separation between primary and secondary circuit
- International approvals EN 60950, CE
- High reliability and long life



Pin	Connection
4	Ext. on/of (DCM, DCG)
6	Current share (DCM, DCG)
8	Sense 0V V ₁
10	Sense + V ₁
12	Output + V ₁
14	Output + V ₁
16	Output 0V V ₁
18	Output 0V V ₁
20	
22	-
24	
26	+ U _E (DCM, DCG)
28	+ U _E
30	0V U _E
32	PE ⊕

Note

The front panel is not included in delivery.

Output data at T _U = 0 ... 50 °C					DC input voltage – Order No. (1 unit) ¹⁾					
Voltage in V	Current in A	Power output in W	Height in U	Width in HP	Power supply Type	A 8.5 – 18 V _{DC}	W 18 – 40 V _{DC}	C 40 – 80 V _{DC}	D 80 – 160 V _{AC}	Front panel anodised
5	4	20	3	4	DCK 105	13103-800³⁾	13103-801	13103-802	13103-803	21008-154
	10	50		8	DCM 105	13103-820	13103-821	13103-822	13103-823	21008-151
	20	100		10	DCG 105	13103-840⁴⁾	13103-841	13103-842	13103-843	21008-150
12	2	24		4	DCK 112	13103-804³⁾	13103-805	13103-806	13103-807	21008-154
	5	60		8	DCM 112	13103-824	13103-825	13103-826	13103-827	21008-151
	9	108		10	DCG 112	13103-844⁴⁾	13103-845	13103-846	13103-847	21008-150
15	1.5	24		4	DCK 115	13103-808³⁾	13103-809	13103-810	13103-811	21008-154
	4	60		8	DCM 115	13103-828	13103-829	13103-830	13103-831	21008-151
	7	105		10	DCG 115	13103-848⁴⁾	13103-849	13103-850	13103-851	21008-150
24	1	24		4	DCK 124	13103-812³⁾	13103-813	13103-814	13103-815	21008-154
	2.5	60		8	DCM 124	13103-832	13103-833	13103-834	13103-835	21008-151
	5	120		10	DCG 124	13103-852⁴⁾	13103-853	13103-854	13103-855	21008-150

¹⁾ Please order front panel and other accessories separately, EMC front panel available on request

³⁾ DCK U_{EDC} = 10.8 – 18 V, open design, case available on request

⁴⁾ In the case of input voltages from 8.5 ... 10.8 volts (longer than 3 minutes), the output power must be reduced by 10 %/volts.

19" compatible DC/DC converters



Technical data

Input parameters				
Input voltages (range)	8.5 – 18 V (A)	18 – 40 V (B)	40 – 80 V (C)	80 – 160 V (D)
Fuse DCM, DCG, (DCK)	25 A (6.3 A)	10 A (4 A)	6.3 A (1.6 A)	3.15 A (0.8 A)
Efficiency	70 – 85 %			
Output parameters				
Output voltages (adjustment range $\pm 5\%$)	5 V	12 V	15 V	24 V
Residual ripple	< 15 mV _{VSS} DCK, < 20 mV _{VSS} DCM, DCG			
Interference voltage (total of all interference parts)	Type < 50 mV			
Mains control (with V_{IN})	< 0.1 %			
Load control ($I_{OUT} = 0 \dots 100\%$)	< 0.2 %			
Control time	< 1 ms at $I_{OUT} = 20 \dots 80\%$			
Temperature coefficient	$\pm 0.025\%/K$			
Power reduction, derating	from +50 °C 3 %/K			
Current limitation	110 % $I_{Nominal}$			
SD external switching on/off	DCM, DCG, TTL compatible			
Remote sense compensated	Max. 0.25 V/line			
DCM, DCG parallel switching	Load sharing, connect all pins 6 with short lines, connect sense directly to load line at connector			
Other data				
Over-voltage protection	Input > 100 % of U_E max., output 125 % $\pm 10\%$ U_{NOM}			
Weight (mass)	DCK 0.3 kg, DCM 0.7 kg, DCG 1 kg			
Electromagnetic compatibility, CE	Interference emission	EN 50081-1, EN 55011 Class B, EN 55022 Class B		
	Interference immunity (degree of severity)	EN 50082-2, EN 61000-4-2 (4), EN 61000-4-3 (10 V/m), EN 61000-4-4 (4), EN 61000-4-5 (3), EN 61000-4-11		
	Safety	EN 60950		
Operating display	Green LED for V_1			
Cooling	Convection			
Ambient temperature T_U operation	0 ... 70 °C			

AC/DC switched mode power supplies

Single, 50 W	3.11.2
Single, 80 W	3.11.4
Single, 100 W	3.11.6
Single, 130 W	3.11.8
Dual, 80 W	3.11.10
Dual, 100 W	3.11.12
Triple, 80 W	3.11.14
Triple, 100 W	3.11.16
Triple, 130 W	3.11.18
Triple, 150 / 224 W	3.11.20
Quad, 250 W	3.11.22
Quad, 350 W	3.11.24

AC/DC linear control systems

Single, 8 – 60 W ..	3.11.26
Dual, 10 – 58 W ...	3.11.28
Triple, 7 – 39 W ...	3.11.30

AC/DC non-regulated

Single, 84 W	3.11.32
Single, 240 W	3.11.34

DC/DC converters

Single, 20 to 120 W	3.11.36
Dual, 55 to 72 W ..	3.11.38
Triple, 64 to 70 W	3.11.40
Quad, 250 W	3.11.42
Quad, 350 W	3.11.44

Accessories

Mating connector female connector	
H 15 F	3.11.46
Keying/coding	3.11.47
Guide rails	3.11.47
Z-rails	3.11.47
EMC contact strips	3.11.48
Wall/horizontal rail installation	3.11.49

Current limitation

DCM, DCG

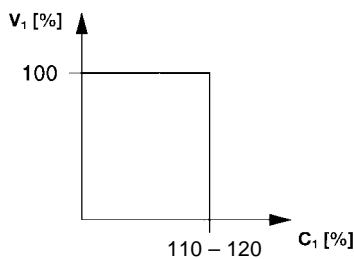

ELKC3878

DCK

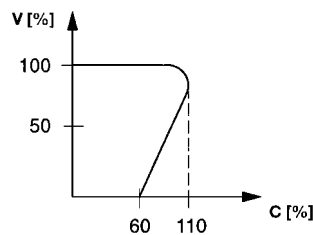

ELKC3877

Temperature-dependent output limitation

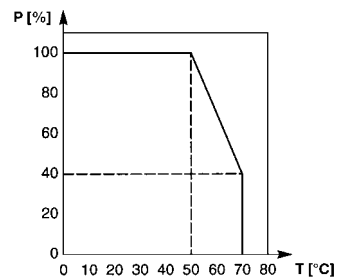

61_34_1

Schematic wiring diagram

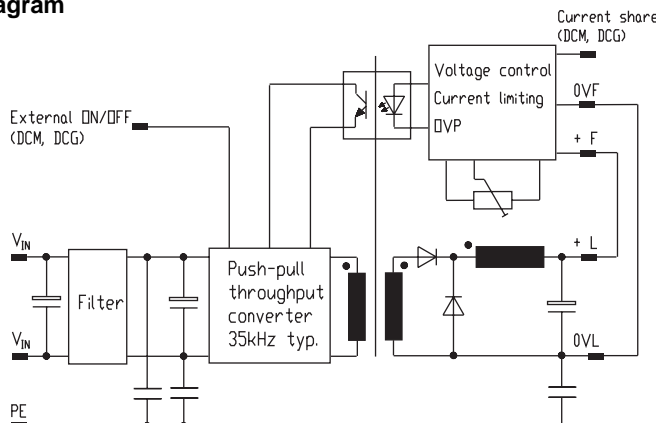

ELKC3873



19" compatible DC/DC converters

Power supply units..... 3.10.0
19" compatible.....3.11.0
 Open frame.....3.12.0
 Power systems.....3.13.0
 Uninterruptable power supplies (UPS)3.14.0

Backplanes/ test adapters .. 3.20.0

Microcomputer packaging systems (MPS) 3.30.0

Appendix..... 3.90.0

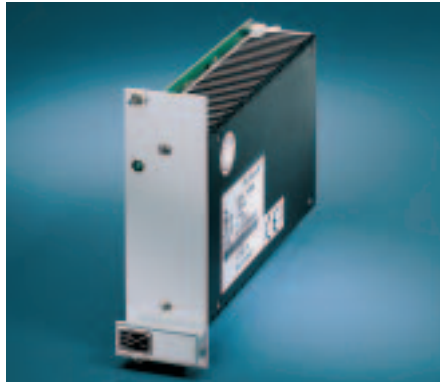

11396008

Dual, 55 to 72 W

- DC series
- Input voltage from 9 to 160 V_{DC} (4 ranges)
- 19" compatible DC/DC switched mode power supplies (3 U)
- 2 output voltages
- Galvanic separation between primary and secondary circuit
- International approvals EN 60950, CE
- High reliability and long life



100 x 160 mm

DUM0084

Pin	Connection
4	
6	
8	
10	Sense GND
12	
14	Output + V ₁
16	
18	GND - V _{1,2}
20	
22	Output + V ₂
24	Sense + V ₂
26	Sense + V ₁
28	+ U _E
30	- U _E
32	PE ⊕

PSA46292

Note
The front panel is not included in delivery.

Output data at T _U = 0 ... 50 °C					DC input voltage – Order No. ¹⁾					
Voltage in V	Current in A	Power output in W	Height in U	Width in HP	Power supply Type	A	W	C	D	Front panel
V ₁ /V ₂	I ₁ /I ₂					8.5–18 V _{DC}	18–40 V _{DC}	40–80 V _{DC}	80–160 V _{AC}	anodised
+5/+12	5/3	61	3	8	DCM 2512	13103-860	13103-861	13103-862	13103-863	21008-153
+5/+15	5/2	55			DCM 2515	13103-864	13103-865	13103-866	13103-867	
+12/-12	3/3	72			DCM 212	13103-868	13103-869	13103-870	13103-871	
+15/-15	2/2	60			DCM 215	13103-872	13103-873	13103-874	13103-875	

¹⁾ Please order front panel and other accessories separately, EMC front panel available on request

Mating connector H15F with FASTON connection, Order No. 69001-733

19" compatible DC/DC converters



Technical data

Input parameters				
Input voltages (range)	8.5 – 18 V (A)	18 – 40 V (B)	40 – 80 V (C)	80 – 160 V (D)
Fuse	25 A	10 A	6.3 A	3,15 A
Efficiency	70 – 85 %			
Output parameters				
Output voltages (adjustment range $\pm 5\%$)	5 V	12 V	15 V	24 V
Residual ripple	< 25 mVss			
Interference voltage (total of all interference parts)	Type < 80 mV			
Mains control (with V_{IN})	< 0.2 %			
Load control ($I_{OUT} = 0 \dots 100\%$)	< 0.2 %			
Control time	< 1 ms at $I_{OUT} = 20 \dots 80\%$			
Temperature coefficient	$\pm 0.025\%/K$			
Power reduction, derating	from +50 °C 3 %/K			
Current limitation	110 % $I_{Nominal}$			
Remote sense compensated	Max. 0.25 V/line			
Other data				
Over-voltage protection, automatically resetting	Input > 100 % of U_E max., output 125 % $\pm 10\%$ U_{NOM}			
Weight (mass)	0.45 kg			
Electromagnetic compatibility, CE	Interference emission, depending on installation	EN 50081-1, EN 55011 Class B, EN 55022 Class B		
	Interference immunity (degree of severity)	EN 50082-2, EN 61000-4-2 (4), EN 61000-4-3 (10 V/m), EN 61000-4-4 (4), EN 61000-4-5 (3), EN 61000-4-6 (10 V), EN 61000-4-11		
	Safety	EN 60950, IEC 950		
Operating display	Green LED for $V_{1,2}$			
Cooling	Convection			
Ambient temperature T_U operation	0 ... 70 °C			

AC/DC switched mode power supplies

Single, 50 W	3.11.2
Single, 80 W	3.11.4
Single, 100 W	3.11.6
Single, 130 W	3.11.8
Dual, 80 W	3.11.10
Dual, 100 W	3.11.12
Triple, 80 W	3.11.14
Triple, 100 W	3.11.16
Triple, 130 W	3.11.18
Triple, 150 / 224 W	3.11.20
Quad, 250 W	3.11.22
Quad, 350 W	3.11.24

AC/DC linear control systems

Single, 8 – 60 W ..	3.11.26
Dual, 10 – 58 W ...	3.11.28
Triple, 7 – 39 W ...	3.11.30

AC/DC non-regulated

Single, 84 W	3.11.32
Single, 240 W	3.11.34

DC/DC converters

Single, 20 to 120 W	3.11.36
Dual, 55 to 72 W ..	3.11.38
Triple, 64 to 70 W	3.11.40
Quad, 250 W	3.11.42
Quad, 350 W	3.11.44

Accessories

Mating connector female connector H 15 F	3.11.46
Keying/coding	3.11.47
Guide rails	3.11.47
Z-rails	3.11.47
EMC contact strips	3.11.48
Wall/horizontal rail installation	3.11.49

Current limitation

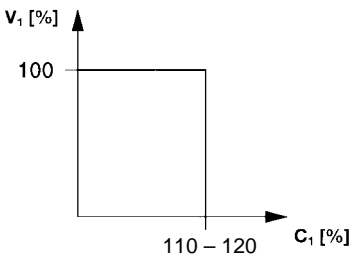

ELKC3878

Temperature-dependent output limitation

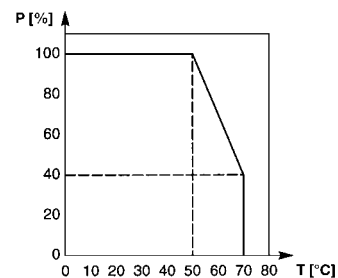

61_34_1

Schematic wiring diagram

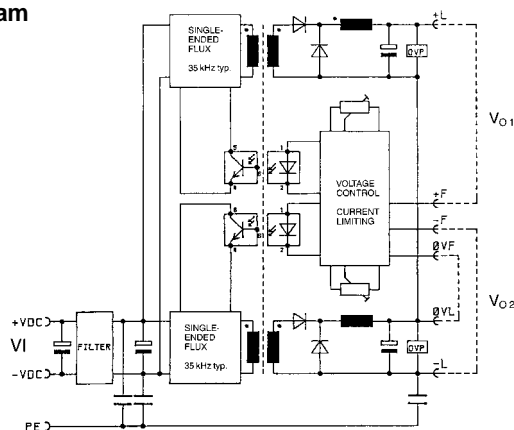

ELKC3874



19" compatible DC/DC converters

Power supply units..... 3.10.0

19" compatible.....3.11.0

Open frame.....3.12.0

Power systems.....3.13.0

Uninterruptable power supplies (UPS)3.14.0

Backplanes/ test adapters .. 3.20.0

Microcomputer packaging systems (MPS) 3.30.0

Appendix..... 3.90.0



11396008

Triple, 64 to 70 W

- DC series
- Input voltage from 8.5 to 160 V_{DC} (4 ranges)
- 19" compatible DC/DC switched mode power supplies (3 U)
- 3 output voltages
- Galvanic separation between primary and secondary circuit
- International approvals EN 60950, CE
- High reliability and long life



100 x 160 mm

DUM0084

Pin	Connection
4	internally assigned
6	internally assigned
8	+ 5 V
10	0V
12	+ 5 V
14	0V
16	internally assigned
18	0V
20	Output V ₂
22	Output V ₃
24	internally assigned
26	SD
28	+ U _E
30	- U _E
32	PE ⊕

PSA46292

Note

The front panel is not included in delivery.

Output data at T _U = 0 ... 50 °C					DC input voltage – Order No. (1 unit) ¹⁾				Front panel	
Voltage in V	Current in A	Power output in W	Height in U	Width in HP	A	W	C	D		
V ₁ /V ₂ /V ₃	I ₁ /I ₂ /I ₃				8.5–18 V _{DC}	18–40 V _{DC}	40–80 V _{DC}	80–160 V _{AC}	anodised	
+5/+12/-12	8/3/1	88	3	8	DCM 312 eco	13103-888	13103-889	13103-890	13103-891	21096-195
+5/+15/-15	8/1/1	70			DCM 315 eco	13103-892	13103-893	13103-894	13103-895	

¹⁾ Please order front panel and other accessories separately, EMC front panel available on request

Mating connector H15F with FASTON connection, Order No. 69001-733

19" compatible DC/DC converters



Technical data

Input parameters	
Input voltages (range)	8.5 – 18 V (A) 18 – 40 V (B) 40 – 80 V (C) 80 – 160 V (D)
Fuse	25 AT 10AT 6.3 AT 6.3 AT
Efficiency	80 – 85 %
Output parameters	
Adjustment range V_1	$5 V \pm 5 \%$
Residual ripple	$< 50 mV_{SS}$, $< 10 mV_{SS}$ at $\pm 15 V$
Interference voltage (total of all interference parts)	Type $< 100 mV_{SS}$
Mains control (with $V_{IN min.}$)	$V_1 < 0.2 \%$, $V_{2,3} < 0.5 \%$
Load control ($I_{OUT} = 0 \dots 100 \%$)	See diagram
Control time	$< 1 ms$ at $I_{OUT} = 20 \dots 80 \%$
Temperature coefficient	$\leq 0.025 \%/K$
Power reduction, derating	from $+50 \text{ }^\circ\text{C}$ 3 %/K
Current limitation	110 % $I_{Nominal}$
SD external switching on/off	TTL compatible
Other data	
Over-voltage protection, automatically recurring	Input $> 100 \%$ of U_E max., output $125 \% \pm 5 \%$ for V_1 , $V_{2,3}$ transzorb diode
Weight (mass)	0.5 kg
Electromagnetic compatibility, CE	Interference emission, depending on installation
	Interference immunity (degree of severity)
	Safety
Operating display	Green LED for V_1
Cooling	Convection
Ambient temperature T_U operation	0 ... 70 °C

AC/DC switched mode power supplies

- Single, 50 W3.11.2
- Single, 80 W3.11.4
- Single, 100 W3.11.6
- Single, 130 W3.11.8
- Dual, 80 W3.11.10
- Dual, 100 W3.11.12
- Triple, 80 W3.11.14
- Triple, 100 W3.11.16
- Triple, 130 W3.11.18
- Triple, 150 / 224 W3.11.20
- Quad, 250 W3.11.22
- Quad, 350 W3.11.24

AC/DC linear control systems

- Single, 8 – 60 W ..3.11.26
- Dual, 10 – 58 W...3.11.28
- Triple, 7 – 39 W...3.11.30

AC/DC non-regulated

- Single, 84 W3.11.32
- Single, 240 W3.11.34

DC/DC converters

- Single, 20 to 120 W3.11.36
- Dual, 55 to 72 W..3.11.38
- Triple, 64 to 70 W3.11.40
- Quad, 250 W3.11.42
- Quad, 350 W3.11.44

Accessories

- Mating connector female connector
- H 15 F3.11.46
- Keying/coding3.11.47
- Guide rails3.11.47
- Z-rails3.11.47
- EMC contact strips.....3.11.48
- Wall/horizontal rail installation3.11.49

Current limitation

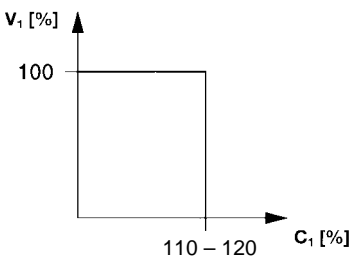

ELKC3878

Temperature-dependent output limitation

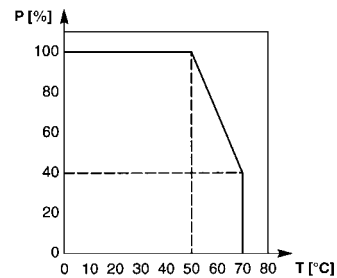

61_34_1

Schematic wiring diagram

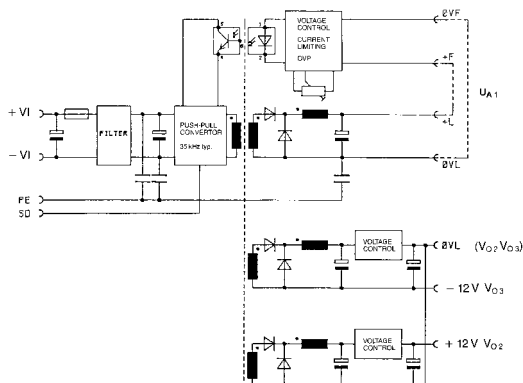

ELKC3875



19" compatible DC/DC converters

Power supply units..... 3.10.0
19" compatible.....3.11.0
 Open frame.....3.12.0
 Power systems.....3.13.0
 Uninterruptable power supplies (UPS)3.14.0
 Backplanes/ test adapters .. 3.20.0
 Microcomputer packaging systems (MPS) 3.30.0
 Appendix..... 3.90.0



11300003

Quad, 250 W *maxpowerPRO*

- 19" compatible DC/DC switched mode power supplies, pluggable 3 U, for compact PCI and other applications
- Input voltage 48 V_{DC}
- 4 output voltages
- Connectors P 47
- Outputs redundant with current share bus
- Hot swap
- Compact PCI signalling
- For industrial and telecommunications applications
- International approvals EN 60950, UL, TÜV, cUL
- High reliability and long life

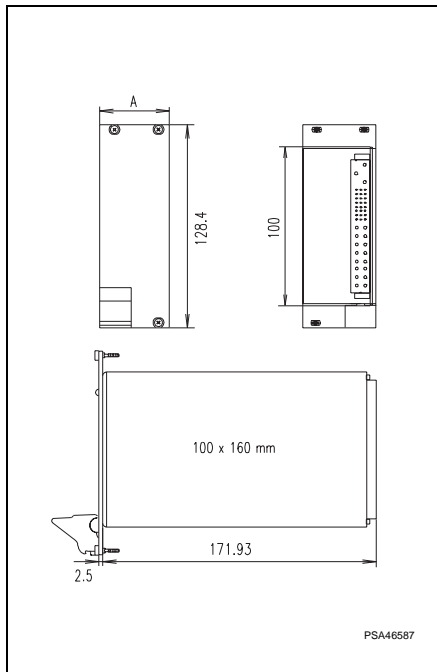

PSA46587

Output data at T _U = 0 ... 50 °C									Order No. (1 unit)			
Voltage				Current ¹⁾				Capacity	Height	Width A	Power supply incl. mounted EMC front panel ²⁾	Mains voltage
V ₁	V ₂	V ₃	V ₄	I ₁	I ₂	I ₃	I ₄	Total (V ₁ + V ₂)	in U	in HP		
5	3.3	+12	-12	25	25	5	1.5	250 (150)	3	8	CPCI 250 DC	36 – 72 V _{DC}

¹⁾ With forced cooling in the system from 2 m/s

²⁾ Front panel: Front panel anodised, rear side chromated, slotted on both sides for mounting EMC contact strips in the event of increased EMC requirements, IEL handle (3 U EMC contact strips, Order No. 21101-853, 10 pieces)

Accessories

Mating connector/intermediate plate 3 U,
Order No. 23098-105

19" compatible DC/DC converters



Technical data

Input parameters					
Input voltage	Nominal value	48 V _{DC}			
	Operating-ranges	36 – 72 V _{DC}			
Input current		9.4 A			
Efficiency type-dependent, typical		> 70 %			
Output parameters					
Output power max.: Convection/forced cooling with 2 m/s		75/150 W		48/78 W	
Output voltage [V]	factory set	V ₁ 5 V	V ₂ 3.3 V	V ₃ 12 V	V ₄ -12 V
	Tolerance	± 50 mV			
Output current [A] 0 ... 50 °C	Convection	15	15	3	1
	Cooling 2 m/s	25	25	5	1.5
	Derating 50 – 70 °C	2 %/K			
Overcurrent protection		all outputs at 120 %			
Residual ripple/ interference voltage (bandwidth = BW)		50 mV _{pp} (BW: 20 MHz)		< 100 mV (BW: 20 MHz)	
Load control		+5 % -3 %		± 5 %	
Cross-control		1 %			
Temperature coefficient		-0.02 %/K (0 – 50 °C)			
Connection two connectors, offset 2.54 mm		(DIN M-8+24), Positronic P47			
Dynamic control deviations (load change: 50 ... 100 % with 100 Hz; di/dt = 0.25 A/μs)					
Overall control time, tolerance 1 % × V _{Nominal}		< 1.5 ms			
Overshoot and undershoot amplitude		< 5 %			

Protection and monitoring facilities		
Switch-on time	< 4 s	
Mains fuse internal	10 A/250 V _{AC} , 5 × 20 mm, DIN 41571	
Switch power supply on/off externally	"INH" = Inhibit ("EN" = Enable) normal high, drive low (high) to turn off (on) (max. 15 V/ 150 μA)	
Over-voltage protection OVP shuts power supply off, restart	120 – 130 % at V _{1,2}	
Remote sense compensated per line	Max. 0.25 V	
Current share with one cable connection	V ₁ , V ₂ , V ₃ , "ISH" signal, tolerance ± 10 %	
Power failure signalling	TTL signal, active high	
"DEG" signal if temperature outside of range (option)	"HIGH" < 50 °C; "LOW" > 50 °C, tolerance ± 5 %	
Power down "FAIL" signal at 70 °C, automatic restart (option)	"HIGH" < 70 °C; "LOW" > 70 °C, tolerance ± 5 %	
Two-color LED, fault/OK status	red/green	
Test and environmental conditions		
Climatic test to	IEC 68-2-38	
Shock and vibration in accordance with	EN 60068-2-6, acceleration of 2 g	
Height 3 U/depth 160 mm	Width 8 HP	
Weight (mass)	2 kg	
CE	Interference emission	CISPR22 Class B, EN 50081-1, EN 55011 Class B
	Interference immunity, degree of severity 3	EN 50082-2, EN 61000-4-2, EN 61000-4-3, EN 61000-4-4, EN 61000-4-5, EN 61000-4-6
	Safety, class of protection 1	EN 60950
High voltage test to EN 60950	Input-output	4.3 kV _{DC}
	Input PE	2.2 kV _{DC}
Safety		UL 1950, cUL, TÜV & CE (applied for)
Power supply maintenance-free		Yes
Necessary cooling for the power supply		2 m/s
Operation/storage ambient temperature		10 ... 70 °C / -40 ... +85 °C
Relative humidity, non-condensing		20 °C – 95 °C
MTBF		200,000 h (50 °C)

AC/DC switched mode power supplies

Single, 50 W	3.11.2
Single, 80 W	3.11.4
Single, 100 W	3.11.6
Single, 130 W	3.11.8
Dual, 80 W	3.11.10
Dual, 100 W	3.11.12
Triple, 80 W	3.11.14
Triple, 100 W	3.11.16
Triple, 130 W	3.11.18
Triple, 150 / 224 W	3.11.20
Quad, 250 W	3.11.22
Quad, 350 W	3.11.24

AC/DC linear control systems

Single, 8 – 60 W ..	3.11.26
Dual, 10 – 58 W ...	3.11.28
Triple, 7 – 39 W ...	3.11.30

AC/DC non-regulated

Single, 84 W	3.11.32
Single, 240 W	3.11.34

DC/DC converters

Single, 20 to 120 W	3.11.36
Dual, 55 to 72 W ..	3.11.38
Triple, 64 to 70 W	3.11.40
Quad, 250 W	3.11.42
Quad, 350 W	3.11.44

Accessories

Mating connector female connector H 15 F	3.11.46
Keying/coding	3.11.47
Guide rails	3.11.47
Z-rails	3.11.47
EMC contact strips	3.11.48
Wall/horizontal rail installation	3.11.49



19" compatible DC/DC converters

- Power supply units..... 3.10.0
- 19" compatible.....3.11.0**
- Open frame.....3.12.0
- Power systems.....3.13.0
- Uninterruptable power supplies (UPS)3.14.0

- Backplanes/ test adapters .. 3.20.0

- Microcomputer packaging systems (MPS) 3.30.0

- Appendix..... 3.90.0



11300009

Quad, 350 W *maxpowerPRO*

- 19" compatible DC/DC switched mode power supplies, pluggable 6 U, for compact PCI and other applications
- Input voltage 48 V_{DC}
- 4 output voltages
- Connectors P 47
- Redundancy operation with current share bus
- Hot swap
- Compact PCI signalling
- For industrial applications
- International approvals EN 60950, UL
- High reliability and long life

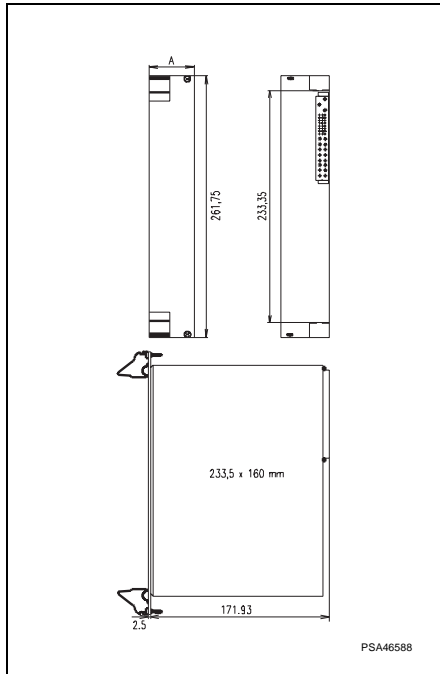

PSA46588

Output data at T _U = 0 ... 50 °C											Order No. incl. mounted EMC front panel ¹⁾	
Voltage in V				Current in A				Power output ²⁾ in W	Height in U	Width A in HP	Power supply Type	Mains voltage
V ₁	V ₂	V ₃	V ₄	I ₁	I ₂	I ₃	I ₄	Total				36 – 72 V _{DC}
5	3.3	+12	-12	30	45	12	3	350	6	8	PCI-3-4DC	11098-142

¹⁾ Front side panel anodised, rear side chromated, slotted on both sides incl. EMC contact strips in the event of increased EMC requirements, two IEL handles (6 U EMC contact strips, Order No. 21101-855, 10 pieces)

²⁾ Forced cooling, total output power V₁ + V₂ = 200 W

Accessories

A 3 U backplane is required for interconnection between power supply and backplane. For assembly into a 6 U system, we offer other solutions - available upon request.

Description see backplanes - Power Bus 3 U, 1 piece, **Order No. 23098-105**

19" compatible DC/DC converters



Technical data

Input parameters				
Input voltage	Nominal value	48 V _{DC}		
	Operating-range	40 – 72 V _{DC}		
Efficiency, typical		75 %		
Output parameters				
Output power max.		350 W		
Output voltages	V ₁	V ₂	V ₃	V ₄
	5 V	3.3 V	12 V	-12 V
Output current 0 ... 50°C	30 A	45 A	12 A	43 A
	Residual ripple/ interference voltage			
		1 % or 100 mV _{SS} ,		
Load control with/without sense		0.5 %/2 %		
Overshoot		1 % switch on/switch off 3 % load change 50 – 100 %		
Mains control, static		0.1 %		
Power failure bridging at 100 % load		20 ms		
Temperature coefficient		-0.02 %/K		
Connection connectors		DIN M24/8		
Basic load		not necessary		

Protection and monitoring facilities		
Switch-on time	< 4 s	
Mains fuse internal	10 A/250 V _{AC}	
Switch power supply on/off externally	Inhibit (enable) normal high, drive low (high) to turn off (on)	
Over-voltage protection (OVP)	all outputs 125 % of the mains voltage; reset via off/on or inhibit/enable	
Over-temperature protection	Automatic shut-off with automatic return	
Overcurrent protection	all outputs	
Remote sense compensated per line	V ₁ , V ₂ , max. 0.5 V	
Current share	V ₁ , V ₂ , V ₃ ,	
Signal: Power failure	TTL signal, active high	
Signal: Temperature outside of range	TTL signal, active high	
Two-color LED, fault/OK status	red/green	
Test and environmental conditions		
Climatic test to	IEC 68-2-38	
Shock and vibration in accordance with	EN 60068-2-6	
Height 3 U/depth 160 mm	Width 8 HP	
Weight (mass)	2.3 kg	
CE	Interference emission	CISPR22 Class B, FCC Part 15, EN 55022
	Interference immunity	EN 50082-1, EN 61000-4-2, EN 61000-4-4, EN 61000-4-5, EN 61000-3-2, EN 61000-3-3
	Safety, class of protection 1	EN 60950
High voltage test to EN 60950	Input-output	4.3 kV _{DC}
	Input PE	2.2 kV _{DC}
Safety		UL, cUL, TÜV & CE
Power supply maintenance-free		Yes
Necessary cooling for the power supply		400 lfm, forced
Operation/storage ambient temperature		0 ... 50°C / -40 ... +85°C
Relative humidity, non-condensing		95 %
MTBF at 25 °C		250,000 h (Bellcore STD.)

AC/DC switched mode power supplies

Single, 50 W	3.11.2
Single, 80 W	3.11.4
Single, 100 W	3.11.6
Single, 130 W	3.11.8
Dual, 80 W	3.11.10
Dual, 100 W	3.11.12
Triple, 80 W	3.11.14
Triple, 100 W	3.11.16
Triple, 130 W	3.11.18
Triple, 150 / 224 W	3.11.20
Quad, 250 W	3.11.22
Quad, 350 W	3.11.24

AC/DC linear control systems

Single, 8 – 60 W ..	3.11.26
Dual, 10 – 58 W ...	3.11.28
Triple, 7 – 39 W ...	3.11.30

AC/DC non-regulated

Single, 84 W	3.11.32
Single, 240 W	3.11.34

DC/DC converters

Single, 20 to 120 W	3.11.36
Dual, 55 to 72 W ..	3.11.38
Triple, 64 to 70 W	3.11.40
Quad, 250 W	3.11.42
Quad, 350 W	3.11.44

Accessories

Mating connector female connector H 15 F	3.11.46
Keying/coding	3.11.47
Guide rails	3.11.47
Z-rails	3.11.47
EMC contact strips	3.11.48
Wall/horizontal rail installation	3.11.49



19" compatible accessories

Power supply units 3.10.0

19" compatible 3.11.0

Open frame 3.12.0

Power systems 3.13.0

Uninterruptable power supplies (UPS) 3.14.0

Backplanes/ test adapters .. 3.20.0

Microcomputer packaging systems (MPS) 3.30.0

Appendix 3.90.0

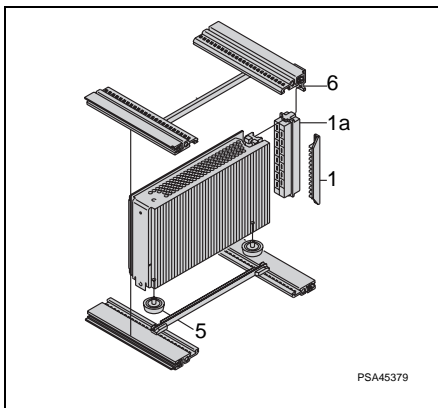

PSA45379



05592018

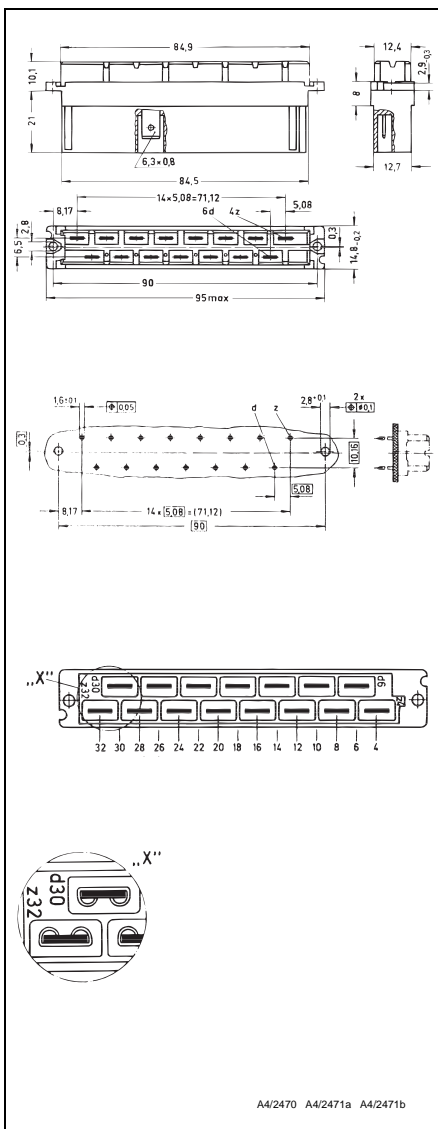

A4/2470 A4/2471a A4/2471b

Accessories

- Mating connector, female connector, H 15 F (Item 1a)
- Keying/coding (Item 1)
- Guide rails (Item 5)
- Z-rails (Item 6)
- EMC contact strips for front panel
- Wall/horizontal rail installation
- Voltage adapter boards for compact PCI power supplies, see Chapter entitled Backplanes – power bus

Mating connector, female connector, H 15 F

- Mating connector for wiring the inputs/outputs (6.3 mm FASTON)
- In all 19" power supplies, the male connector(s) is (are) pin 32 with advanced earthing contact

Item	Qty	Description	Description	Order No.
1a	1	Mating connector female connector H 15 F	Wiring with Faston connector 6.3 × 0.8 mm	69001-733

19" compatible accessories

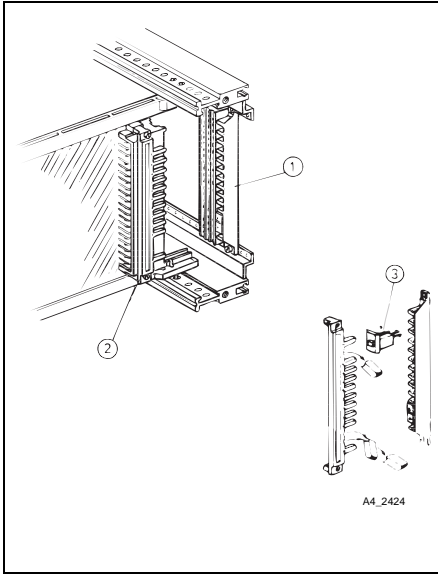

Keying/coding

- Mechanical keying/coding prevents the insertion of a power supply in the incorrect position
- Connector keying/coding with with a comb strip (Item 2, fixed to power supply – except for MPS and DC series) and contact strip (assembly to the horizontal rail)
- Space requirement 4 HP
- With 2 keying/coding pins 66, and with 6 keying/coding pins, 924 keying/coding possibilities

Item	Qty	Description	Description	Order No.
1	1	Contact strip	Crastin (UL 94-V-0)	60800-123
3	2	Keying/coding pin		

Note

Item 2 is mounted at the power supply as standard

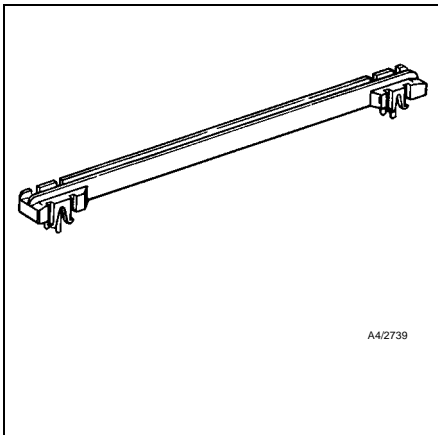

Guide rails

- For engaging into horizontal rails, see Item 5
- Groove width 2 mm
- 2 versions for light and heavy power supplies

Description	Description	Board length mm	Order No.
Guide rail	Standard version for light power supplies < 1.2 kg	160	60817-103
		220	60817-149
	Reinforced version for heavy power supplies > 1.2 kg	160	60817-102
		220	60817-085

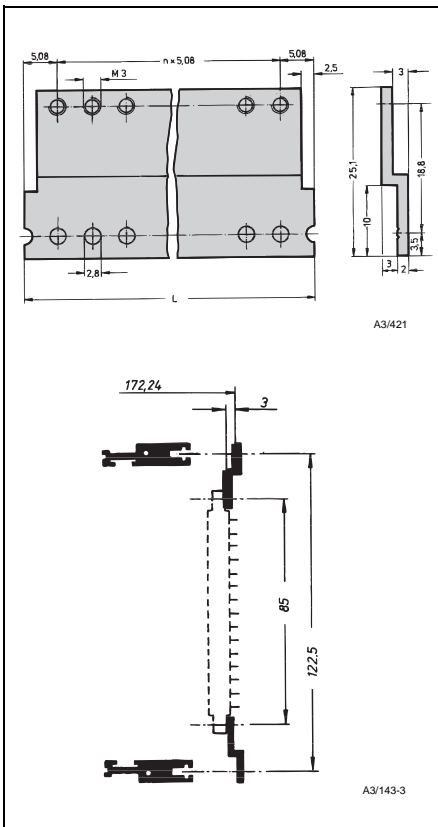

Z-rails

- For fixing the mating connector onto the rear horizontal rail (Item 6)
- Serves to create the standard mounting depth of the power supplies
- Short Z-rails 4 HP width

Qty	Description	Description	Order No.
1	Z-rails	4 HP (20.32 mm)	30822-166

AC/DC switched mode power supplies

- Single, 50 W3.11.2
- Single, 80 W3.11.4
- Single, 100 W3.11.6
- Single, 130 W3.11.8
- Dual, 80 W3.11.10
- Dual, 100 W3.11.12
- Triple, 80 W3.11.14
- Triple, 100 W3.11.16
- Triple, 130 W3.11.18
- Triple, 150 / 224 W3.11.20
- Quad, 250 W3.11.22
- Quad, 350 W3.11.24

AC/DC linear control systems

- Single, 8 – 60 W ..3.11.26
- Dual, 10 – 58 W ...3.11.28
- Triple, 7 – 39 W ...3.11.30

AC/DC non-regulated

- Single, 84 W3.11.32
- Single, 240 W3.11.34

DC/DC converters

- Single, 20 to 120 W3.11.36
- Dual, 55 to 72 W ..3.11.38
- Triple, 64 to 70 W3.11.40
- Quad, 250 W3.11.42
- Quad, 350 W3.11.44

Accessories

- Mating connector female connector H 15 F3.11.46
- Keying/coding3.11.47
- Guide rails3.11.47
- Z-rails3.11.47
- EMC contact strips3.11.48
- Wall/horizontal rail installation3.11.49



19" compatible accessories

Power supply units..... 3.10.0

19" compatible.....3.11.0

Open frame.....3.12.0

Power systems.....3.13.0

Uninterruptable power supplies (UPS)3.14.0

Backplanes/ test adapters .. 3.20.0

Microcomputer packaging systems (MPS) 3.30.0

Appendix..... 3.90.0

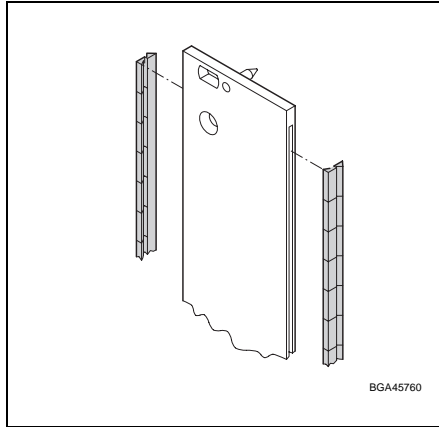

EMC contact strips

For shielded front panels with slots.

Material: Stainless steel

Height U	Length mm	Qty	Order No.
3	97	10	21101-705
		100	21101-706
4	142	10	21101-713
		100	21101-714
6	232	10	21101-707
		100	21101-708

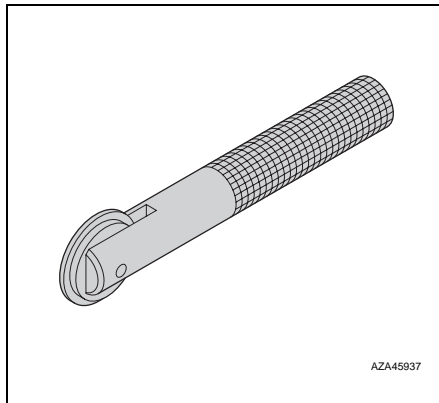

Assembly tool for EMC contact strips

Material: Aluminium

Order No. (1 piece) **24560-270**

19" compatible accessories



11395007

Wall/horizontal rail installation

- Suitable for 19" compatible power supplies with 3 U
- Wall-mounting bracket can be mounted in any position using screws, power supply is pushed in.
- Horizontal rail bracket is screwed onto the wall-mounting bracket – the 19" power supply can therefore be clipped onto the horizontal rail with lip.

Item	Qty	Description	Description	Order No.
1	1	Wall-mounting bracket	Steel	11000-001
2	1	Horizontal rail bracket	Al	11000-002

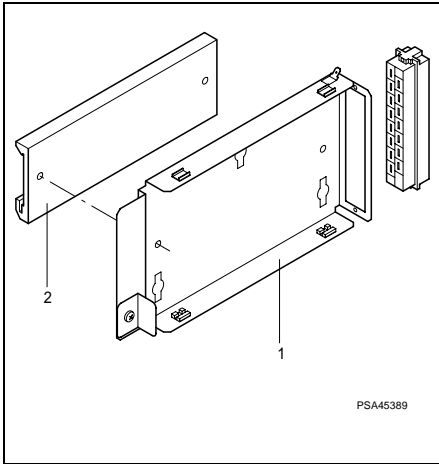

PSA45389

Note

Female connector H 15 F is also required.

AC/DC switched mode power supplies

- Single, 50 W3.11.2
- Single, 80 W3.11.4
- Single, 100 W3.11.6
- Single, 130 W3.11.8
- Dual, 80 W3.11.10
- Dual, 100 W3.11.12
- Triple, 80 W3.11.14
- Triple, 100 W3.11.16
- Triple, 130 W3.11.18
- Triple, 150 / 224 W3.11.20
- Quad, 250 W3.11.22
- Quad, 350 W3.11.24

AC/DC linear control systems

- Single, 8 – 60 W ..3.11.26
- Dual, 10 – 58 W...3.11.28
- Triple, 7 – 39 W...3.11.30

AC/DC non-regulated

- Single, 84 W3.11.32
- Single, 240 W3.11.34

DC/DC converters

- Single, 20 to 120 W3.11.36
- Dual, 55 to 72 W..3.11.38
- Triple, 64 to 70 W3.11.40
- Quad, 250 W3.11.42
- Quad, 350 W3.11.44

Accessories

- Mating connector female connector H 15 F3.11.46
- Keying/coding3.11.47
- Guide rails3.11.47
- Z-rails3.11.47

- EMC contact strips.....3.11.48
- Wall/horizontal rail installation3.11.49

New

19" compatible AC/DC switched mode



Power Supply
19" compatible..... 38



11302001



Single 42 W

slimpower

- Width only 3 HP
- 1 output voltage
- Low Emission
- 19" compatible AC/DC switch controller, pluggable 3HP/ 3 U, DIN 41494, part 5)
- High performance
- Redundancy operation with integrated decoupling diode
- Current share in parallel operation via Current Share Bus operation
- Wide range mains input voltage (range from 85 – 254 V_{AC} and 120 – 360 V_{DC})
- Signal: output voltage OK
- For measuring, controlling, regulating, studio and industrial applications
- High reliability and long service life
- Cost-optimized

113 02 502

Pin	Connection
4	Output + V ₁
6	
8	Sensor line + V ₁
10	Sensor line 0 V V ₁
12	Output 0 V V ₁
14	
16	
18	
20	Output OK
22	
24	
26	
28	L
30	N
32	PE ⊕

PSA46292

Note

Delivery does not include a front panel.

Voltage in V	Output data at T _{ambient} = 0 ... 50 °C				Power supply type	Order No. ¹⁾	
	Current in A	Power in W	Height in U	Width A in HP		Mains/line voltage 90 – 254 V _{AC}	Front panel ²⁾ EMC version
5	6.0	30	3	3	SLE 105	13100-136	21006-959
12	3.5	42			SLE 112	13100-137	
15	2.8	41			SLE 115	13100-138	
24	1.7	41			SLE 124	13100-139	

¹⁾ Please order front panel separately

²⁾ Front anodised, rear chromated, slotted on both side for mounting EMC contact strips in the case of increased EMC requirements (3 U EMC contact strips, 10 pieces, Order No. 21101-705)

Mating-connector H15F with FASTON connection, 1 piece, Order No. 69001-733

New

19" compatible AC/DC switched mode



Power supply
19" compatible

AC/DC switched mode
power supply

Single adjustable,
100 W1

Technical data

Input variables					
Mains/line voltage	Rated values V_{AC}	100 – 240 V_{AC}			
	Working range	85 – 254 V_{AC} 120 – 360 V_{DC}			
Rated mains current at 90 V_{AC} / 230 V_{AC}		0,9 / 0,4 A			
Mains frequency range		50 – 60 Hz			
Input current according to		EN 61000-3-2 + A14			
Efficiency		typ. 70 – 80 %			
Current at switch-on I_P (at 230 V_{AC})		< 20 A			
Discharge current		≤ 500 μ A			
Output variables					
> 190 V_{AC} / > 85 V_{AC}					
Output power [W]		30 / 30	42 / 32	41 / 34	
Output voltage [V]	factory setting	5	12	15	24
	Adjustment range Δ V	4,3 – 6,0	11,1 – 15,5	22,8 – 25,7	
Output current [A] at $T_{ambient}$	0 ... 50°C	6,0 / 6,0	3,5 / 2,7	2,8 / 2,1	1,7 / 1,4
	70°C	4,0 / 4,0	2,0 / 2,0	1,6 / 1,6	1,0 / 1,0
Current limitation, resistant to permanent short-circuit, U/I curve up to $V_1 \geq [V]$ if V_1 after long overload becomes smaller, the power supply goes in the hic up mode		1,5	4,5	4,5	7,0
Overvoltage protection (OVP, power supply switches off, automatically returning, factory setting [V])		6,1 ±0,3 V	16,1 ±0,75 V		26,4 ±1,25
Residual ripple included Interference voltage (BW: 30 MHz) typ. [mV _{PP}] max. [mV _{PP}]		7 10	9 15	10 15	
Mains and load control, static (load change 0 – 100 %) [mV _{PP}]		< 10		< 15	
Temperature coefficient		-0,015 %/K			
output controlled via diode		built-in, CS- operating possible			
Dynamic control deviations					
(Load change: 50 ... 100 % with 100 Hz; $di/dt = 0,25$ A/ μ s)					
Total control time, tolerance $0,01 \times V_1 N_{enn}$ [ms]		< 1,5			
Overshoot and undershoot amplitude [mV]		< 300	< 250		

Switch-on time		< 1,5 s		
Mains fuse slow	2 A / 250 V_{AC} , IEC 60127-3 / IV			
Power failure bridging for $V_{AC} = 230$ V_{AC} and 100 % load	> 20 ms			
Remote sense compensation	max. 0,5 V			
Current limitation curve	U/I			
Signal "output voltage ok"	"Output OK"			
High level factory setting [V], "LOW" active with internal resistor, adjustable on Open Collector "LOW" or "HIGH" active	5	12	15	24
Testing and environmental conditions				
Climatic test based on		IEC 68-2-38		
Shock and vibration test based on acceleration 2 g		EN 60068-2-6		
Dimensions		Height 3 U / Depth 160 mm / Width 3 HP		
Weight		0,27 kg		
CE	Interference emission	EN 50081-1: EN 55011 class B, EN 55022 class B		
	Interference immunity	EN 61000-6-2		
	Safety, protection class 1	EN 60950, to UL 1950		
High voltage test complying with EN 60950	Input-Output	4,3 kV _{DC}		
	Input PE	2,2 kV _{DC}		
	Output PE	0,7 kV _{DC}		
Power supply, maintenance-free		Yes		
Cooling type		Convection		
Ambient temperature operation/storage		0 ... 70°C / -20 ... +85°C		
MTBF at full load, $T_{ambient} = 40$ °C		> 400.000 h		

Circuit diagram

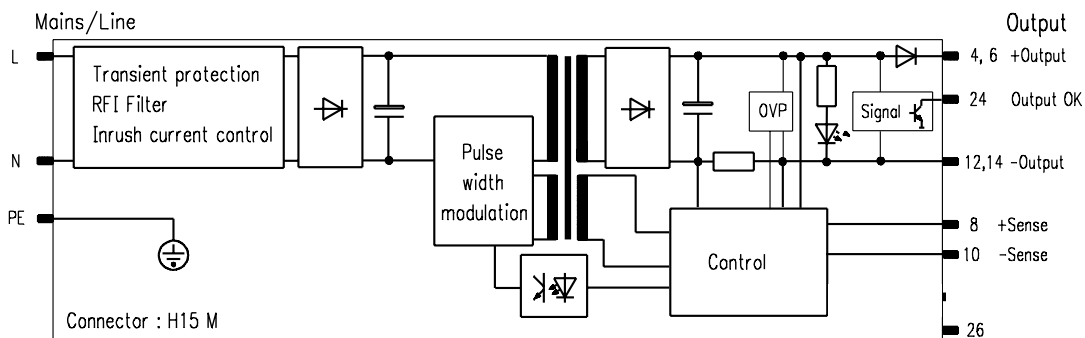

DJM0002

19" compatible AC/DC switch controller



Power supply
19" compatible

AC/DC switched mode
power supply

Single adjustable,
100 W38

DC/DC converter

Single, 100 W40

Dual, 100 W42

Triple, 100 W44

Technical data

Input variables			
Mains/line voltage	Rated values V_{AC}	100 – 240 V_{AC}	
	Working range	90 – 254 V_{AC}	
Rated mains current at 90 V_{AC}		1.6 A	
Mains frequency range		50 – 60 Hz	
Power Factor Correction complying with		EN 61000-3-2	
Efficiency dependent on output voltage		64 – 80 %	70 – 82 %
Current at switch-on I_P (at 230 V_{AC})		< 20 A	
Output variables		190/90 V_{AC}	
Output voltage [V]	factory setting	12	24
	Adjustment range ΔV	4.5 – 17	16 – 30
Output current [A]	0 ... 50°C	5.9 / 4.2	3.4 / 2.5
	70°C	4.2/3.4	2.5/2
Output power max. (50 °C) [W]		100 / 72	102 / 77
Current limitation deactivates the output after approx. 10 ms, automatically returning after approx. 2 s, after long overload power supply switches off		Permanently secured against short circuit	
Residual ripple/ Interference voltage (BW: 30 MHz) [mV _{PP}]		< 100	< 150
Mains and load control, static (load change 0 – 100 %) [mV _{PP}]		< 120	< 250
Temperature coefficient		-0.015 %/K	
CSB and output controlled via diode		built-in	
Dynamic control deviations (Load change: 10 ... 100 % with 100 Hz; $di/dt = 0.25 A/\mu s$)			
Total control time, tolerance 1 % $\times V_1$ nominal [ms]		<0.2	<0.2
Overshoot and undershoot amplitude [mV]		< 180	

Protection and monitoring devices			
Switch-on time		< 0.8 s	
Mains fuse, high breaking, slow		4 A/250 V_{AC} , 5 \times 20 mm, EN 60127-2/V	
Power failure bridging for mains/line voltage-operating range and 100 % load		4.5 – 12 V > 20 ms 12 – 17 V > 10 ms	16 – 24 V > 20 ms 24 – 28 V > 10 ms 28 – 30 V > 5 ms
Over-voltage protection OVP limits the U_A to		< 22 V	< 38 V
Remote sensing, compensated		max. 0.5 V	
Signal "output voltage ok"		Signal "Output OK", active high	
High level [V]		3–20 V	13–20 V
Time delay		100 – 250 ms	
Testing and environmental conditions			
Climatic test based on		IEC 68-2-38	
Shock and vibration test based on acceleration 2 g		EN 60068-2-6	
Height 3 U/ Depth 160 mm/Width [HP]		6	
Weight (mass)		0.55 kg	
CE	Interference emission	EN 50081-1: EN 55011 Class B	
	Interference immunity, degree of severity 3	EN 50082-2: EN 61000-4-2, EN 61000-4-3, EN 61000-4-4, EN 61000-4-5, EN 61000-4-6, EN 61000-4-11	
	Safety, protection class 1	complies with EN 60950	
High voltage test complying with EN 60950	Input-Output	4.3 kV _{DC}	
	Input PE	2.2 kV _{DC}	
	Output PE	0.7 kV _{DC}	
Power supply, maintenance-free		Yes	
Cooling type		Convection	
Ambient temperature operation/storage		0 ... 70°C / -20 ... +85°C	
MTBF at full load, $T_{ambient} = 40^\circ C$		270,000 h (5 V – 220.000 h)	

Circuit diagram

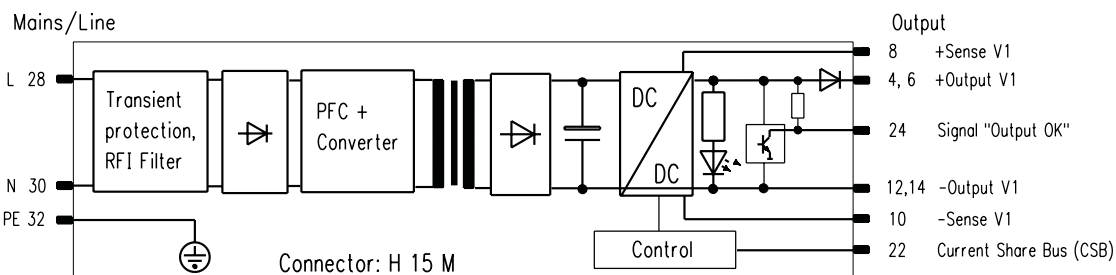

DJIM0032

19" compatible DC/DC converter



**Power supply
19" compatible**

**AC/DC switched mode
power supply**

Single adjustable,
100 W 38

DC/DC converter

Single, 100 W 40

Dual, 100 W 42

Triple, 100 W 44

Technical data

Input variables			
Input voltage range	20–72 V		
Fuse, internal	15 A		
Efficiency	84 – 90 %		
Output variables			
Output power	100 W	102 – 105 W	108 W
Output voltages	5 V	12 V – 15 V	24 V
Output current (50 °C)	20 A	8.5 A – 7 A	4.5 A
Residual ripple	< 20 mV _{SS}	< 50 mV _{SS}	< 80 mV _{SS}
Interference voltage (BW: 30 MHz)	< 100 mV _{SS}		
Input voltage control (20 – 72 V)	<0.1 %		
Load control (I _{Out} = 0 ... 100 %)	<0.2 %		
Load control	< 1 ms at load change 10 ... 100 %		
Temperature coefficient	±0.025 %/K		
Derating	from + 50 °C: 3 %/K		
Current limitation	110 % I _{nominal}		
External switching on/off	TTL compatible		
Remote sensing compensated	max 0.25 V / cable		
Parallel switching possible	Redundancy diode mounted		
Other data			
Overvoltage protection	Input	present	
	Output	U _{nominal} + 20 %	
Weight (mass)	0.3 kg		
Electromagnetic compatibility, CE	Interference emission	EN 50081-1: EN 55011 Class B, EN 55022 Class B	
	Interference immunity (Degree of severity)	EN 61000-6-2 EN 61000-4-2, EN 61000-4-3, EN 61000-4-4, EN 61000-4-5, EN 61000-4-6, EN 61000-4-11	
	Safety	Complying with EN 60950	
Operating display	green LED for V ₁		
Cooling type	Convection		
Ambient temperature T _U Operation	0 ... 70 °C		

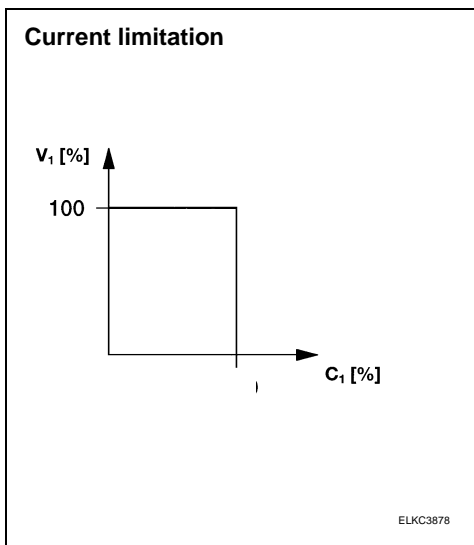

New

19" compatible DC/DC converter

Case
ratiopacPRO/-air 4

Power Supply
19" compatible..... 38

Backplanes
CompactPCI..... 46



11301001

Dual, 100 W

- 19" compatible DC/DC switch controller (3 U)
- 2 output voltages
- Galvanic isolation between primary and secondary circuit
- Large input voltage range of 20 to 72 V_{DC}
- Very high efficiency
- High performance
- High reliability and long service life



100 x 160 mm

DUM0084

PSA46292

Pin	Connection
4	
6	
8	
10	-
12	
14	
16	Output + V ₁
18	Output 0 V V _{1,2}
20	Output 0 V V ₂
22	
24	-
26	Ext. ON/OFF*
28	+ Input
30	0 V Input
32	PE ⊕

*reference point 0 V input

Note

Delivery does not include a front panel.

Output data at T _{ambient} = 0 ... 50 °C							Order No. ¹⁾		
Voltage ³⁾ in V		Current in A		Capacity	Height	Width:	Power supply		Front panel ²⁾
V ₁	V ₂	I ₁	I ₂	in W	in HE	in HP	Type		EMC version
+12	-12	4.5	4.5	108	3	6	CPDC 212	13103-007	21006-956

¹⁾ Please order front panel separately

²⁾ Front anodised, rear chromated, slotted on both side for mounting EMC contact strips in the case of increased EMC requirements
(3 U EMC contact strips, 10 units, Order No. 21101-705)

³⁾ Adjustment range up to 15 V

Mating-connector H15F with FASTON connection, Order No. 69001-733

19" compatible DC/DC converter



Technical data

Input variables		
Input voltage range	20–72 V	
Fuse, internal	15 A	
Efficiency	87 – 90 %	
Output variables		
Output power	108 W	105 W
Output voltage	± 12 V	± 15 V
Output current (50 °C)	4.5 A	3.5 A
Residual ripple	< 50 mV _{SS}	
Interference voltage	< 100 mV _{SS}	
Input voltage control (20 – 72 V)	<0.1 %	
Load control (I _{Out} = 0 ... 100 %)	V ₁ < 0.2 %, V ₂ < 3 % with 10 % base load at V ₁	
Load control	< 1 ms at load change 10 ... 100 %	
Temperature coefficient	±0.025 %/K	
Derating	from + 50 °C: 3 %/K	
Current limitation	110 % I _{nominal}	
External switching on/off	TTL compatible	
Other data		
Overvoltage protection	Input	present
Weight (mass)	0.3 kg	
Electromagnetic compatibility, CE	Interference emission	EN 50081-1: EN 55011 Class B, EN 55022 Class B
	Interference immunity (Degree of severity)	EN 61000-6-2 EN 61000-4-2, EN 61000-4-3, EN 61000-4-4, EN 61000-4-5, EN 61000-4-6, EN 61000-4-11
	Safety	Complying with EN 60950
Operating display	green LED for V ₁ and V ₂	
Cooling type	Convection	
Ambient temperature T _U Operation	0 ... 70 °C	

**Power supply
19" compatible**

**AC/DC switched mode
power supply**

Single adjustable,
100 W 38

DC/DC converter

Single, 100 W 40

Dual, 100 W 42

Triple, 100 W 44

Current limitation

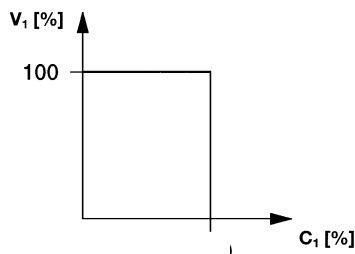

ELKC3878

New

19" compatible DC/DC converter

Case
ratiopacPRO/-air 4

Power Supply
19" compatible..... 38

Backplanes
CompactPCI..... 46



11301001

Triple, 100 W

- 19" compatible DC/DC switch controller (3 U)
- 3 output voltages
- Galvanic isolation between primary and secondary circuit
- Large input voltage range of 20 to 72 V_{DC}
- External switching on/off
- Very high efficiency
- High performance
- High reliability and long service life



100 x 160 mm

DUJM0084

PSA46292

Pin	Connection
4	Output + V ₁
6	
8	Sensor line + V ₁
10	Sensor line 0 V V ₁
12	Output 0 V V ₁ (V ₂)
14	
16	Output + V ₂
18	Output 0 V V ₂ (V ₁)
20	Output 0 V V ₃
22	Output -V ₃
24	Output OK
26	-
28	+ Input
30	0 V Input
32	PE ⊕

Note

Delivery does not include a front panel.

Output data at T _{ambient} = 0 ... 50 °C								Order No. ¹⁾			
Voltage in V			Current in A			Capacity in W	Height in U	Width: in HP	Power supply		Front panel ²⁾ EMC version
V ₁	V ₂ ³⁾	V ₃ ³⁾	I ₁	I ₂	I ₃				Type		
+5	+12	-12	10	2	2	98	3	6	CPDC 312	13103-016	21006-957

¹⁾ Please order front panel and other accessories separately, EMV front panel available on request

²⁾ Front anodised, rear chromated, slotted on both side for mounting EMC contact strips in the case of increased EMC requirements

(3 U EMC contact strips, Qty. 10, Order No. 21101-705)

³⁾ Adjustment range up to 15 V

Mating-connector H15F with FASTON connection, Order No. 69001-733

19" compatible DC/DC converter



Technical data

Input variables			
Input voltage range	20–72 V		
Fuse, internal	15 A		
Efficiency	typ. 85%		
Output variables			
Output power	50 W	48 W	51 W
Output voltages	5 V	± 12 V	± 15 V
Output current (50 °C)	10 A	2 A	1.7 A
Residual ripple	< 20 mV _{SS}	< 50 mV _{SS}	
Interference voltage (BW: 30 MHz)	< 100 mV _{SS}		
Input voltage control (20 – 72 V)	< 0.1 %		
Load control (I _{Out} = 0 ... 100 %)	V _{1, 2, 3} < 0.2 %		
Load control	< 1 ms at load change 10 ... 100 %		
Temperature coefficient	± 0.05 %/K		
Derating	from + 50 °C: 3 %/K		
Current limitation	110 % I _{nominal}		
External switching on/off	TTL compatible		
Remote sensing compensated	V ₁ max. 0.25 V / cable		
Parallel switching	at V ₂ and V ₃ possible		
Series switching	at V ₂ and V ₃ possible		
Other data			
Over-voltage protection, input	present		
Weight (mass)	0.4 kg		
Electromagnetic compatibility, CE	Interference emission	EN 50081-1: EN 55011 Class B, EN 55022 Class B	
	Interference immunity (Degree of severity)	EN 61000-6-2 EN 61000-4-2, EN 61000-4-3, EN 61000-4-4, EN 61000-4-5, EN 61000-4-6, EN 61000-4-11	
	Safety	Complying with EN 60950	
Operating display	green LED for V ₁ , V ₂ and V ₃		
Cooling type	Convection		
Ambient temperature T _A Operation	0 ... 70 °C		

**Power supply
19" compatible**

**AC/DC switched mode
power supply**

Single adjustable,
100 W 38

DC/DC converter

Single, 100 W 40

Dual, 100 W 42

Triple, 100 W 44

Current limitation

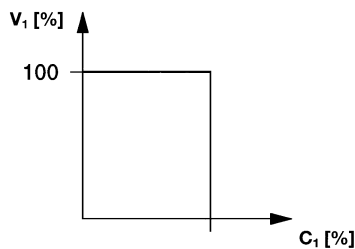

ELKC3878