

SIEMENS

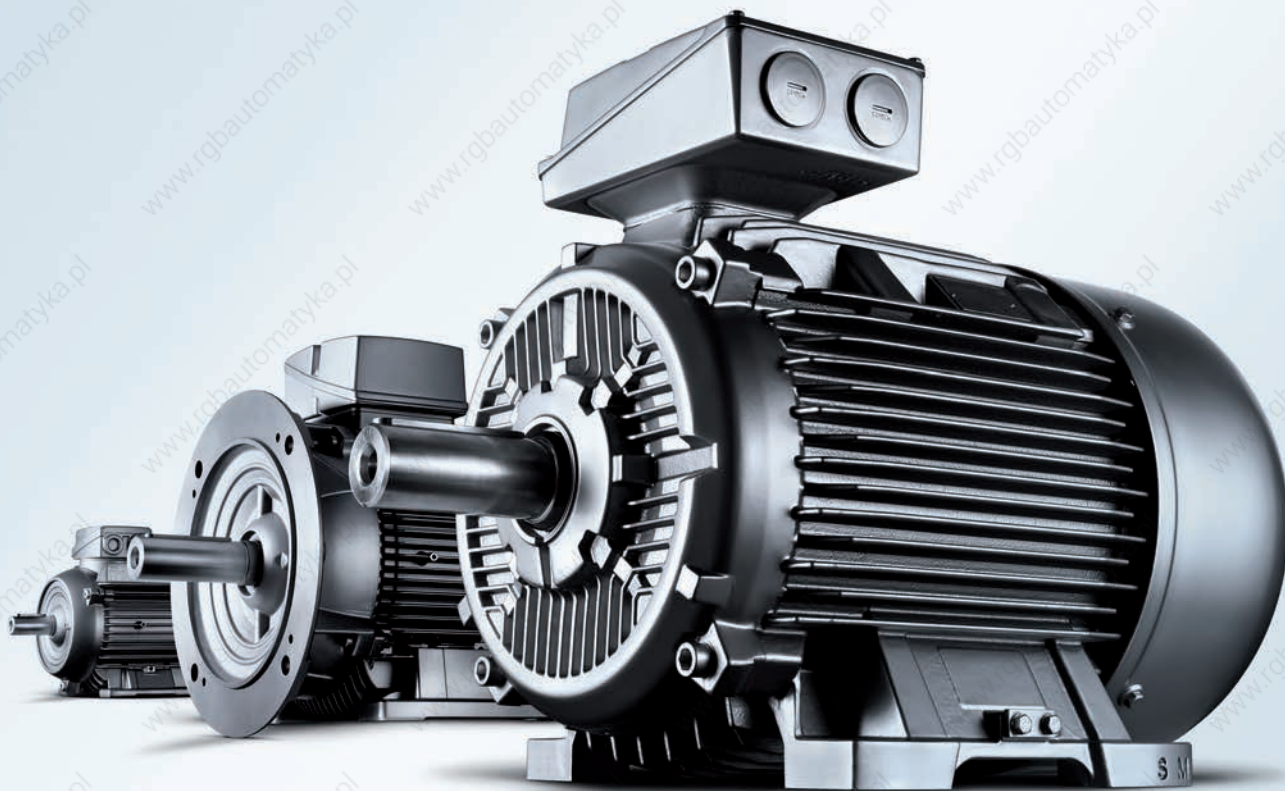

SIMOTICS Low-Voltage Motors

Distribution offering

This technical brochure focuses on a selected motor spectrum specifically defined for the distribution business covering all main standard applications and industries

Edition
11/2012

Additional information is provided in the following documents and/or links:

- SIMOTICS Low-voltage Motors
Catalog D81.1 January 2012
Order No.: E86060-K5581-A111-A4-7600
- SIMOTICS GP 1LE0 Low-voltage Motors
Catalog D81.5N 09.2011
Order No. E20001-K0369-C600-X-5D00
- Energy saving/Energy-saving program SinaSave
Further information regarding energy savings and the energy-saving program SinaSave can be found at the following internet addresses:
www.siemens.com/sinasave
www.siemens.com/energysaving
- Selection tool DT Configurator
The DT Configurator covers the product range of low-voltage motors and MICROMASTER 4 / SINAMICS inverters and converters as well as frequency converters for SIMATIC ET 200 distributed I/O. The range of available products is being continuously expanded.

The following information is provided for the individual products:
 - 2D/3D-model generator for motors and converters
 - Data sheet generator
 - Start-up calculation for motors
 - Comprehensive product-specific documentationwww.siemens.com/dt-configurator
- Additional documentation
You will find all information material, such as brochures, catalogs, manuals and operating instructions for standard drive systems up-to-date on the Internet at the address
www.siemens.com/motors/printmaterial

You can order the listed documentation or download it in common file formats (PDF, ZIP).

- Further information about
Drive Systems > Variable-Speed Drives, e.g.,

| | |
|--|-------|
| SINAMICS and Motors for Single-Axis Drives | D31 |
| SINAMICS G130 Drive Converter Chassis Units | D11 |
| SINAMICS G150 Drive Converter Cabinet Units | |
| SINAMICS S120 Chassis Format Units and Cabinet Modules | D21.3 |

can be obtained at
www.siemens.com/drives/infocenter

This brochure is only applicable in the following countries:

- ASEAN
 - Republic of Indonesia
 - Kingdom of Thailand
 - Malaysia
 - Socialist Republic of Vietnam
 - Republic of Singapore
 - Republic of the Philippines
 - Republic of Korea
- South America
 - Republic of Chile
 - Argentine Republic
- Middle East
 - United Arab Emirates
 - Kingdom of Saudi Arabia
 - Islamic Republic of Pakistan
- Africa
 - Republic of South Africa
 - Arab Republic of Egypt
- South Asia
 - People's Republic of Bangladesh

Content

| | |
|--|-----------|
| Introduction | 4 |
| General overview | 4 |
| SIMOTICS Distribution Motors | |
| Key features | 6 |
| Special features | 7 |
| Applicable standards and specifications. | 9 |
| Motor selection | 10 |
| Motor selection and order number structure | 10 |
| Type of construction. | 17 |
| SIMOTICS General Purpose – Aluminum series | |
| IE1 Efficiency | 18 |
| IE2 Efficiency | 19 |
| SIMOTICS General Purpose – Cast Iron series | |
| IE1 Efficiency | 20 |
| IE2 Efficiency | 23 |
| Distribution Motor Options. | 26 |
| Special features detail | 30 |
| Efficiency | 30 |
| IP rating | 32 |
| Thermal class | 33 |
| Derating | 34 |
| Anti-condensation | 35 |
| Motor protection | 36 |
| Converter-fed application. | 37 |
| Noise. | 40 |
| Bearing | 42 |
| Terminal box. | 50 |
| Dimension drawings | 52 |
| Aluminum series – 1LA7 | 54 |
| Aluminum series – 1LE10. | 54 |
| Cast Iron series – 1LE0 | 56 |
| Flange dimensions | |
| Aluminum series – 1LA7 | 58 |
| Aluminum series – 1LE10. | 59 |
| Cast Iron series – 1LE0 | 59 |
| User parts | 60 |
| Handling and storage | 62 |



Introduction

General overview

SIMOTICS – The name for the widest range of motors in the world

With 150 years of experience, we have driven motor technology forward, optimized them and played a decisive role in defining them.

Based on over 150 years of experience Siemens offers with SIMOTICS the most comprehensive range of motors for industrial applications proven with more than 40 million Siemens motors and drives installed around the world.

Our low-voltage motors meet the latest efficiency standards and stand for highest quality, reliability and compactness. Our motors are optimally integrated into the drive train. They are perfectly harmonized for the use with SIRIUS motor starters and SINAMICS frequency converters.

Our foundation of outstanding quality is the unparalleled experience from numerous Siemens production facilities around the world and close to our customers. This is how our experience drives your success!

Siemens is present in more than 190 countries around the world and a true local global player. We manufacture locally serving the individual markets. All of our products are based on one common global quality and design standard derived from our German engineering roots adapted to global market requirements.

We are present in your local market, understand your market's needs and also comply with local requirements and standards.

Let us show you how our experience and our partnership will drive your success with a new motors series specifically defined for the distribution business.



SIMOTICS low-voltage motors

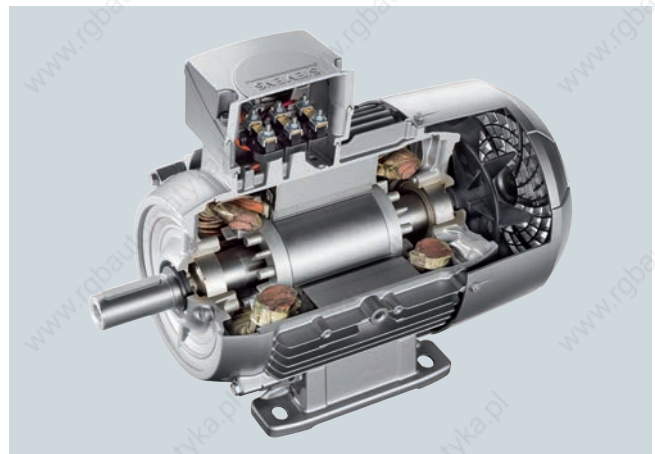

Cut-away aluminum motor



This brochure is using all of our 150 years experience and focuses on our SIMOTICS low-voltage IEC motors, especially defined for the distribution market. It covers both Aluminum and Cast Iron series motors for general purpose. Additional offering is always available from our standard motor catalog portfolio. We comply with the latest efficiency standards and describe motors for both the IE1 and IE2 efficiencies.

Although Siemens also has ranges for IE3 and specific solutions for IE4 efficiency, these are still considered specialized and are not described in this document. In addition to these general IE1 and IE2 solutions, Siemens can also provide specific variants for specific markets i.e. in India, Korea, China etc. In such instances please consult your local Siemens representative.

Our motor offering for the distribution market already includes the most common features required in your local market and country, e.g. drain holes, embedded PTCs and more.



SIMOTICS 1LE0 Cast Iron motor



IE1 Aluminum Motor (1LE10 & 1LA7)

- Frame size: 63 – 160
- Rated output: 0.12 – 18.5 kW
- No. of poles: 2, 4 and 6
- Voltage & frequency: 400 V \pm 5%, 50 Hz and other voltages and frequencies
- Type of construction: IM B3 and other types of construction

IE2 Aluminum Motor (1LE10)

- Frame size: 80 – 160
- Rated output: 0.55 – 18.5 kW
- No. of poles: 2, 4 and 6
- Voltage & frequency: 400 V \pm 5%, 50 Hz and other voltages and frequencies
- Type of construction: IM B3 and other types of construction



IE1 Cast Iron Motor (1LE0)

- Frame size: 80 – 355
- Rated output: 0.55 – 315 kW
- No. of poles: 2, 4 and 6
- Voltage & frequency: 400 V \pm 5%, 50 Hz and other voltages and frequencies
- Type of construction: IM B3 and other types of construction

IE2 Cast Iron Motor (1LE0)

- Frame size: 80 – 355
- Rated output: 0.55 – 315 kW
- No. of poles: 2, 4 and 6
- Voltage & frequency: 400 V \pm 5%, 50 Hz and other voltages and frequencies
- Type of construction: IM B3 and other types of construction

SIMOTICS Distribution Motors – Key features

In order to maximize inventory turn rates, minimize complexity, decrease stock levels and minimize your investment required, we defined a specific distribution portfolio already including most common required features as standard. In addition we offer an additional selection of options with which you can modify the distribution offering even more.

Besides we can always offer you the most comprehensive motor portfolio made to order for all applications and industries available from our standard catalog portfolio D81.1 and SIMOTICS GP 1LE0 Low-voltage Motors catalog offering D81.5N 09-2011.

The low-voltage motor unique key features:

1. Low vibration

The low vibration results from our precision manufacturing and the use of defined and controlled quality components. The quality bearings used augment this and result in longer life and lower noise. See chapter 1 – Applicable standards and specifications for details.

2. Drain hole as standard (1LE0)

Drain holes as standard make sure condensed water does not stay inside of the motor. This is especially important in humid environment and big temperature deltas.

3. Bearing for high cantilever forces and longer lifetime

Bearings in our motors are not only designed for high cantilever forces, but also to make sure the motors run smooth.

4. True IP55 as standard

Our IP55 design covers a vast majority of applications and is tested and proven for full lifetime, plus you have the full modification possibility within IP55 rating.

5. F to B thermal class for built-in reserve

The Siemens motors are rated at normal sinusoidal voltage with a class B (130 °C) temperature rise. The windings are rated to class F (155 °C) thus allowing for reserve for the additional losses associated with variable speed drive operation and / or higher ambient temperature and / or overload conditions when operating directly on-line. F to F is possible for converter-fed operation.

6. Converter-fed operation for variable speed as standard

For all motors offered up to 460 V converter-fed operation is possible as standard configuration – no special option or series is needed.

7. Embedded thermal protection 3x PTC (1LE0/1LA7 and 1LE1 motors)

Thermal protection with PTC thermistors with 3 embedded temperature sensors for tripping is provided in our IE2 motors above frame size 112 as standard version.

8. Global motor platform

Our motor design is based on one global motor platform with the same look and feel on all low-voltage motor IEC products.

9. Prepared for easy modification and mount auxiliaries

Our distribution motors are equipped with metal fan cover and center hole on non-drive end shaft for easy modification and mount auxiliaries.

For details on the above mentioned key features, please see chapter 3 "Special features detail".

SIMOTICS Distribution Motors – Special features

| SIMOTICS General Purpose | | | | | |
|--|-------------------------------------|-------------------------------------|-------------------------------------|-------------------------------------|--------------------------|
| Efficiency class | Aluminum Series | | | Cast Iron Series | |
| | IE1 | | IE2 | IE1 | IE2 |
| | 1LA7 | 1LE1002 | 1LE1001 | 1LE0102 | 1LE0101 |
| 1 Low vibration | <input type="checkbox"/> | <input type="checkbox"/> | <input type="checkbox"/> | <input type="checkbox"/> | <input type="checkbox"/> |
| 2 Drain hole as the standard | <input checked="" type="checkbox"/> | <input checked="" type="checkbox"/> | <input checked="" type="checkbox"/> | <input type="checkbox"/> | <input type="checkbox"/> |
| 3 Bearing for high cantilever forces and longer lifetime | <input type="checkbox"/> | <input type="checkbox"/> | <input type="checkbox"/> | <input type="checkbox"/> | <input type="checkbox"/> |
| 4 IP55 as the standard | <input type="checkbox"/> | <input type="checkbox"/> | <input type="checkbox"/> | <input type="checkbox"/> | <input type="checkbox"/> |
| 5 F to B thermal class | <input type="checkbox"/> | <input type="checkbox"/> | <input type="checkbox"/> | <input type="checkbox"/> | <input type="checkbox"/> |
| 6 Converter-fed operation for variable torque | <input type="checkbox"/> | <input type="checkbox"/> | <input type="checkbox"/> | <input type="checkbox"/> | <input type="checkbox"/> |
| 7 Embedded thermal protection 3xPTC | <input checked="" type="checkbox"/> | <input checked="" type="checkbox"/> | <input checked="" type="checkbox"/> | <input checked="" type="checkbox"/> | <input type="checkbox"/> |
| 8 Global motor platform | <input type="checkbox"/> | <input type="checkbox"/> | <input type="checkbox"/> | <input type="checkbox"/> | <input type="checkbox"/> |
| 9 Prepared for easy modification and auxiliary mounting | - | <input checked="" type="checkbox"/> | <input checked="" type="checkbox"/> | - | <input type="checkbox"/> |

= Standard

= Option in distribution portfolio

- = Not available

| | | 63 | 71 | 80 | 90 | 100 | 112 | 132 | 160 | 180 | 200 | 225 | 250 | 280 | 315 | 355 | Series | |
|-----------|-------------------------|----------------------|----|----|----|--------------------------|-----|-----|-----|---------|-----|-----|-----|-----|-----------------|-----|--------|---|
| Aluminum | Standard Efficiency IE1 | 1LA7 0.09 ... 2.2 kW | | | | | | | | | | | | | | | | 1 |
| | | | | | | 1LE1002 1.5 ... 18.5 kW | | | | | | | | | | | | 2 |
| | High Efficiency IE2 | | | | | 1LE1001 0.37 ... 18.5 kW | | | | | | | | | | | | 3 |
| Cast Iron | Standard Efficiency IE1 | | | | | | | | | 1LE0102 | | | | | 0.55 ... 315 kW | | 4 | |
| | High Efficiency IE2 | | | | | | | | | 1LE0101 | | | | | 0.55 ... 315 kW | | 5 | |

Did you know?



An oversized motor is seldom recommended, it normally has disadvantages including:

- Higher cost in investment and operation
- A higher current resulting from a poorer power factor
- A bigger frame size and extended dimensions.

SIMOTICS Distribution Motors – Special features

| SIMOTICS General Purpose | | | | | | |
|----------------------------|---|------------------------------|------------------------------|------------------------------|------------------------------|------------------------------|
| Efficiency class Series | | Aluminum Series | | | Cast Iron Series | |
| | | IE1 | | IE2 | IE1 | IE2 |
| | | 1LA7 | 1LE1002 | 1LE1001 | 1LE0102 | 1LE0101 |
| Voltage and frequency | Standard | 400 V ± 5% | 400 V ± 5% | 400 V ± 5% | 400 V ± 5% | 400 V ± 5% |
| | Optional voltage @ 50 Hz | 380 V, 415 V, 525 V | 380 V, 415 V, 525 V | 380 V, 415 V, 525 V | 380 V, 415 V, 525 V | 380 V, 415 V, 525 V |
| | Converter-fed operation ^(a) | □ | □ | □ | □ | □ |
| Type of construction | Standard | IM B3 | IM B3 | IM B3 | IM B3 | IM B3 |
| | Optional | IM B35, IM B5, IM V1, IM B14 | IM B35, IM B5, IM V1, IM B14 | IM B35, IM B5, IM V1, IM B14 | IM B35, IM B5, IM V1, IM B14 | IM B35, IM B5, IM V1, IM B14 |
| Bearing designation | Bearing 62 C | □ | □ | □ | □ ^(b) | □ ^(b) |
| | Bearing 63 C | – | ◇ | ◇ | □ ^(b) | □ ^(b) |
| Others | Metal fan cover | □ | ✓ | ✓ | □ | □ |
| | Metal rating plate | □ | – | – | □ | □ |
| | Drain hole | ◇ | ◇ | ◇ | □ ^(b) | □ ^(b) |
| | Center hole at non-drive end prepared for auxiliary mountings | – | ✓ ^(b) | ✓ | – | □ ^(b) |
| | Space heater | ✓ | ✓ | ✓ | ✓ | ✓ |
| Motor protection | 3 x PTC | ✓ | ✓ | ✓ | ✓ | □ ^(b) |
| Certificate | Extra rating plate for voltage tolerance | ✓ | ✓ | ✓ | □ | □ |
| | CE marking | – | – | □ | – | □ |
| | Routine test | ✓ | ✓ | ✓ | ✓ | ✓ |

□ = Standard

✓ = Option in distribution portfolio

◇ = Not available in distribution portfolio, only from standard catalog

– = Not available

^(a) = The limit for converter-fed operation is 460 V_{rms}.^(b) = Depending on frame size and/or number of poles, please see respective sections.

TIP



All motors up to 460 V can be operated either directly on line or converter-fed – without the need for any additional measures. Both is possible as standard.

TIP



On our SIMOTICS GP 1LE0 motors we have an additional sticker mentioning voltage deviation as standard. On our other product line, deviations should be mentioned, please add option code B07.

TIP



All our motors are shown as 400 V as the nominal standard. The IEC 60034 regulations state that the nameplate data is only valid at the specific given voltage. In practice, all listed 400 V motors may be used at connection voltages 400 V ± 5%. The motors will function well, although there would be deviations from the nominal electrical nameplate data. All 1LE0 motors will have a sticker in addition on the cowl as standard giving the nominal connection voltage as 400 V ± 5%. According to the standard, motors can also be operated at 400 V ± 10% (Category B), only longer operation is not recommended.

Applicable standards and specifications

| Title | IEC |
|--|-------------------|
| Efficiency classes and efficiencies | IEC 60034-30:2008 |
| Rotating electrical machines – Part 1: Rating and performance | IEC 60034-1 |
| Rotating electrical machines – Part 2-1: Standard methods for determining losses and efficiency from tests (excluding machines for traction vehicles) | IEC 60034-2 |
| Rotating electrical machines – Part 5: Degrees of protection provided by the integral design of rotating electrical machines (IP code) – Classification | IEC 60034-5 |
| Rotating electrical machines – Part 6: Methods of cooling (IC Code) | IEC 60034-6 |
| Rotating electrical machines – Part 7: Classification of types of construction, mounting arrangements and terminal box position (IM Code) | IEC 60034-7 |
| Rotating electrical machines – Part 8: Terminal markings and direction of rotation | IEC 60034-8 |
| Rotating electrical machines – Part 9: Noise limits | IEC 60034-9 |
| Rotating electrical machines – Part 14: Mechanical vibration of certain machines with shaft heights 56 mm and higher – Measurement, evaluation and limits of vibration severity | IEC 60034-14 |
| Rotating electrical machines – Part 1: Frame numbers 56 to 400 and flange numbers 55 to 1080 | IEC 60072-1 |
| Electrical insulation – Thermal classification | IEC 60085 |
| Classification of environmental conditions Part 2-1: Environmental conditions appearing in nature – Temperature and humidity | IEC 60721-2-1 |
| Standard voltages | IEC 60038 |

IEC 60034-1 differentiates between Category A (combination of voltage deviation $\pm 5\%$ and frequency deviation $\pm 2\%$) and Category B (combination of voltage deviation $\pm 10\%$ and frequency deviation $+3\% / -5\%$) for voltage and frequency fluctuations.

The motors can supply their rated torque in both Category A and B. In Category A, the temperature rise is approximately 10 K higher than during normal operation.

| Standard 60034-1 | Category A | Category B |
|--|---|---|
| Voltage deviation | $\pm 5\%$ | $\pm 10\%$ |
| Frequency deviation | $\pm 2\%$ | 3 % / -5 % |
| Rating plate data stamped with rated voltage a (e.g. 230 V) | a $\pm 5\%$ (e.g. 230 V $\pm 5\%$) | a $\pm 10\%$ (e.g. 230 V $\pm 10\%$) |
| Rating plate data stamped with rated voltage ranges b to c (e.g. 220 V to 240 V) | b -5 % to c +5 % (e.g. 220 V -5 % to 240 V +5 %) | b -10 % to c +10 % (e.g. 220 V -10 % to 240 V +10 %) |

Rotors are dynamically balanced with half key. This corresponds to vibration quantity level A.

Tolerance for electrical data

- Efficiency η at
 - $P_{\text{rated}} \leq 150 \text{ kW}$: $-0.15 \times (1 - \eta)$
 - $P_{\text{rated}} > 150 \text{ kW}$: $-0.10 \times (1 - \eta)$
 - With η being a decimal number
- Power factor - $(1 - \cos \phi) / 6$
 - Minimum absolute value: 0.02
 - Maximum absolute value: 0.07
- Slip $\pm 20\%$ (for motors $< 1 \text{ kW}$ $\pm 30\%$ is admissible)
- Locked-rotor current +20 %
- Locked-rotor torque -15 % to +25 %
- Breakdown torque -10 %
- Moment of inertia $\pm 10\%$

| Limits (rms values) for max. vibration quantity of vibration distance (s), vibration speed (v) and acceleration (a) for the shaft height H | | | | | | | | | | |
|--|----------------------|-----------------------------------|--------------------------|---------------------------------------|-----------------------------------|--------------------------|---------------------------------------|-----------------------------------|--------------------------|---------------------------------------|
| Vibration quantity level | Machine installation | Shaft height H in mm | | | | | | | | |
| | | 56 \leq H \leq 132 | | | 132 < H \leq 280 | | | H > 280 | | |
| | | s_{rms} μm | v_{rms} mm/s | a_{rms} mm/s ² | s_{rms} μm | v_{rms} mm/s | a_{rms} mm/s ² | s_{rms} μm | v_{rms} mm/s | a_{rms} mm/s ² |
| A | Free suspension | 25 | 1.6 | 2.5 | 35 | 2.2 | 3.5 | 45 | 2.8 | 4.4 |
| | Rigid clamping | 21 | 1.3 | 2.0 | 29 | 1.8 | 2.8 | 37 | 2.3 | 3.6 |
| B | Free suspension | 11 | 0.7 | 1.1 | 18 | 1.1 | 1.7 | 29 | 1.8 | 2.8 |
| | Rigid clamping | – | – | – | 14 | 0.9 | 1.4 | 24 | 1.5 | 2.4 |

Motor selection

Motor selection and order number structure

Here is our comprehensive distribution motor portfolio, offering both Aluminum and Cast Iron series IE1 and IE2 efficiency. Our portfolio is covering power ratings from 0.09 kW up to 315 kW and frame sizes 63 to 355.

| SIMOTICS General Purpose | | | | | | | | | | |
|--------------------------|--------------------------|---|---|--------------------------|---|---|--------------------------|---|---|---|
| Aluminum Series | | | | | | | | | | |
| Efficiency class | IE1 | | | | | | IE2 | | | |
| Series | 1LA7 | | | 1LE1002 | | | 1LE1001 | | | |
| No. of poles | 2 | 4 | 6 | 2 | 4 | 6 | 2 | 4 | 6 | |
| Cooling | Self-ventilated (IC 411) | | | Self-ventilated (IC 411) | | | Self-ventilated (IC 411) | | | |
| Degree of protection | IP55 | | | IP55 | | | IP55 | | | |
| Insulation | Thermal class 155(F) | | | Thermal class 155(F) | | | Thermal class 155(F) | | | |
| Utilization | Thermal class 130(B) | | | Thermal class 130(B) | | | Thermal class 130(B) | | | |
| Frame size | 63 ... 90 | | | 100 ... 160 | | | 80 ... 160 | | | |
| Rated output at 50 Hz | 0.09 ... 2.2 kW | | | 1.5 ... 18.5 kW | | | 0.37 ... 18.5 kW | | | |
| Rated torque at 50 Hz | 0.61 ... 11 Nm | | | 10 ... 109 Nm | | | 2.6 ... 108 Nm | | | |
| Rated power (kW) | 0.09 | - | - | ✓ | - | - | - | - | - | - |
| 0.12 | - | ✓ | - | - | - | - | - | - | - | - |
| 0.18 | ✓ | ✓ | ✓ | - | - | - | - | - | - | - |
| 0.25 | ✓ | ✓ | ✓ | - | - | - | - | - | - | - |
| 0.37 | ✓ | ✓ | ✓ | - | - | - | - | - | ✓ | ✓ |
| 0.55 | ✓ | ✓ | ✓ | - | - | - | - | ✓ | ✓ | ✓ |
| 0.75 | ✓ | ✓ | ✓ | - | - | - | ✓ | ✓ | ✓ | ✓ |
| 1.1 | ✓ | ✓ | ✓ | - | - | - | ✓ | ✓ | ✓ | ✓ |
| 1.5 | ✓ | ✓ | - | - | - | ✓ | ✓ | ✓ | ✓ | ✓ |
| 2.2 | ✓ | - | - | - | ✓ | ✓ | ✓ | ✓ | ✓ | ✓ |
| 3 | - | - | - | ✓ | ✓ | ✓ | ✓ | ✓ | ✓ | ✓ |
| 4 | - | - | - | ✓ | ✓ | ✓ | ✓ | ✓ | ✓ | ✓ |
| 5.5 | - | - | - | ✓ | ✓ | ✓ | ✓ | ✓ | ✓ | ✓ |
| 7.5 | - | - | - | ✓ | ✓ | ✓ | ✓ | ✓ | ✓ | ✓ |
| 11 | - | - | - | ✓ | ✓ | ✓ | ✓ | ✓ | ✓ | ✓ |
| 15 | - | - | - | ✓ | ✓ | - | ✓ | ✓ | - | - |
| 18.5 | - | - | - | ✓ | - | - | ✓ | - | - | - |

✓ = Available
- = Not available

Did you know



Aluminum is a better conductor of heat than Cast Iron. For this reason Aluminum motors can feel warmer – keeping the inside cooler. Cast Iron may feel colder on the outside but the motor is sweating more on the inside.

General note:

All data shown in this brochure is reflecting 50 Hz data if not otherwise specified.



Did you know

All our described motors have a repeated starting capability.

Those motors used on a frequency converter ramping quickly from 0 Hz do not overheat and have an unlimited starting capability. (also see section “converter-fed application”)

Those motors started direct on-line heat slightly each time they start. The number of starts can only be calculated if many parameters are known.

As a rule, three successive normal starts for a cold motor and two successive starts for a warm motor are accepted.

SIMOTICS General Purpose

Cast Iron Series

| Efficiency class | Cast Iron Series | | | | | |
|-----------------------|--------------------------|---|---|--------------------------|---|---|
| | IE1 | | | IE2 | | |
| Series | 1LE0102 | | | 1LE0101 | | |
| No. of poles | 2 | 4 | 6 | 2 | 4 | 6 |
| Cooling | Self-ventilated (IC 411) | | | Self-ventilated (IC 411) | | |
| Degree of protection | IP55 | | | IP55 | | |
| Insulation | Thermal class 155(F) | | | Thermal class 155(F) | | |
| Utilization | Thermal class 130(B) | | | Thermal class 130(B) | | |
| Frame size | 80 ... 355 | | | 80 ... 355 | | |
| Rated output at 50 Hz | 0.55 ... 315 kW | | | 0.55 ... 315 kW | | |
| Rated torque at 50 Hz | 2.6 ... 2412 Nm | | | 2.6 ... 2412 Nm | | |

Rated power (kW)

| Rated power (kW) | 2 | 4 | 6 | 2 | 4 | 6 |
|------------------|---|---|---|---|---|---|
| 0.55 | - | ✓ | x | - | ✓ | ✓ |
| 0.75 | ✓ | ✓ | x | ✓ | ✓ | ✓ |
| 1.1 | ✓ | ✓ | ✓ | ✓ | ✓ | ✓ |
| 1.5 | ✓ | ✓ | ✓ | ✓ | ✓ | ✓ |
| 2.2 | ✓ | ✓ | ✓ | ✓ | ✓ | ✓ |
| 3 | ✓ | ✓ | ✓ | ✓ | ✓ | ✓ |
| 4 | ✓ | ✓ | ✓ | ✓ | ✓ | ✓ |
| 5.5 | ✓ | ✓ | ✓ | ✓ | ✓ | ✓ |
| 7.5 | ✓ | ✓ | ✓ | ✓ | ✓ | ✓ |
| 11 | ✓ | ✓ | ✓ | ✓ | ✓ | ✓ |
| 15 | ✓ | ✓ | ✓ | ✓ | ✓ | ✓ |
| 18.5 | ✓ | ✓ | ✓ | ✓ | ✓ | ✓ |
| 22 | ✓ | ✓ | ✓ | ✓ | ✓ | ✓ |
| 30 | ✓ | ✓ | ✓ | ✓ | ✓ | ✓ |
| 37 | ✓ | ✓ | ✓ | ✓ | ✓ | ✓ |
| 45 | ✓ | ✓ | ✓ | ✓ | ✓ | ✓ |
| 55 | ✓ | ✓ | ✓ | ✓ | ✓ | ✓ |
| 75 | ✓ | ✓ | ✓ | ✓ | ✓ | ✓ |
| 90 | ✓ | ✓ | ✓ | ✓ | ✓ | ✓ |
| 110 | ✓ | ✓ | ✓ | ✓ | ✓ | ✓ |
| 132 | ✓ | ✓ | ✓ | ✓ | ✓ | ✓ |
| 160 | ✓ | ✓ | ✓ | ✓ | ✓ | ✓ |
| 185 | ✓ | ✓ | ✓ | ✓ | ✓ | ✓ |
| 200 | ✓ | ✓ | ✓ | ✓ | ✓ | ✓ |
| 220 | ✓ | ✓ | ✓ | ✓ | ✓ | ✓ |
| 250 | ✓ | ✓ | ✓ | ✓ | ✓ | ✓ |
| 280 | ✓ | ✓ | - | ✓ | ✓ | - |
| 315 | ✓ | ✓ | - | ✓ | ✓ | - |

✓ = Available
- = Not available

Motor selection and order number structure

Besides the already embedded distribution features we offer an additional selection of options with which you can customize the distribution offering even more. The option range covers mainly different voltages and mounting types, mechanical design and many other commonly required features.

Note:

Please refer to chapter 2 for distribution motor option selection.

| Aluminum | Series | Frame size availability |
|---|--------|-------------------------|
| SIMOTICS GP 1LA7 Standard Efficiency IE1 | 1 | |
| SIMOTICS GP 1LE10 Standard Efficiency IE1 | 2 | |
| SIMOTICS GP 1LE10 High Efficiency IE2 | 3 | |
| Cast Iron | | |
| SIMOTICS GP 1LE0 Standard Efficiency IE1 | 4 | |
| SIMOTICS GP 1LE0 High Efficiency IE2 | 5 | |

| | 63 | 71 |
|---|-------------------------------------|-------------------------------------|
| Voltage and frequency | | |
| 400 V, 50 Hz | <input type="checkbox"/> | <input type="checkbox"/> |
| 380 V, 50 Hz | <input checked="" type="checkbox"/> | <input checked="" type="checkbox"/> |
| 415 V, 50 Hz | <input checked="" type="checkbox"/> | <input checked="" type="checkbox"/> |
| 525 V, 50 Hz | <input checked="" type="checkbox"/> | <input checked="" type="checkbox"/> |
| Type of construction | | |
| IM B3 | <input type="checkbox"/> | <input type="checkbox"/> |
| IM B35 | <input checked="" type="checkbox"/> | <input checked="" type="checkbox"/> |
| IM B5 | <input checked="" type="checkbox"/> | <input checked="" type="checkbox"/> |
| IM V1 ^(a) | <input checked="" type="checkbox"/> | <input checked="" type="checkbox"/> |
| IM B14 | <input checked="" type="checkbox"/> | <input checked="" type="checkbox"/> |
| Mechanical design and degrees of protection | | |
| Condensation drain holes | <input type="checkbox"/> | <input type="checkbox"/> |
| Drive-end seal for flange-mounting motors, oil-tight to 0.1 bar | <input checked="" type="checkbox"/> | <input checked="" type="checkbox"/> |
| Heating and ventilation | | |
| Anti-condensation heating for 230 V | <input checked="" type="checkbox"/> | <input checked="" type="checkbox"/> |
| Anti-condensation heating for 115 V | <input checked="" type="checkbox"/> | <input checked="" type="checkbox"/> |
| Motor protection | | |
| Motor protection with PTC thermistors with 1 (for motors 1LE10 FS 80 and 90) or 3 embedded temperature sensors for tripping | <input checked="" type="checkbox"/> | <input checked="" type="checkbox"/> |
| Bearing and lubrication | | |
| Bearing design for increased cantilever forces | <input type="checkbox"/> | <input type="checkbox"/> |
| Regreasing device | <input type="checkbox"/> | <input type="checkbox"/> |
| Packing, safety notes, documentation and certificate | | |
| Extra rating plate for voltage tolerance | <input checked="" type="checkbox"/> | <input checked="" type="checkbox"/> |
| Acceptance test certificate 3.1 in accordance with EN 10204 (routine test) | <input checked="" type="checkbox"/> | <input checked="" type="checkbox"/> |
| CE marking | <input type="checkbox"/> | <input type="checkbox"/> |
| Sea-worthy packing for export | <input type="checkbox"/> | <input type="checkbox"/> |

= Standard

= Option in distribution portfolio

= Not available in distribution portfolio, only from standard catalog

– = Not available

^(a) = For canopy as modification, please see chapter 5

^(b) = Depends on frame size or number of poles, please see respective sections

^(c) = Only for IE2 motors



Did you know

Motors can be offered with anti-condensation heating as an option.

Retrofitting of small motors is not so easy.

An alternative is to switch one delta-winding or two star-winding connections across a lower voltage supply. The motor cannot turn and is heated. The voltage should be selected at ~10% of the nominal.

| 80 | 90 | 100 | 112 | 132 | 160 | 180 | 200 | 225 | 250 | 280 | 315 | 355 |
|--------------------------|--------------------------|--------------------------|--------------------------|--------------------------|--------------------------|--------------------------|--------------------------|--------------------------|--------------------------|--------------------------|--------------------------|--------------------------|
| <input type="checkbox"/> | <input type="checkbox"/> | <input type="checkbox"/> | <input type="checkbox"/> | <input type="checkbox"/> | <input type="checkbox"/> | <input type="checkbox"/> | <input type="checkbox"/> | <input type="checkbox"/> | <input type="checkbox"/> | <input type="checkbox"/> | <input type="checkbox"/> | <input type="checkbox"/> |
| ✓ | ✓ | ✓ | ✓ | ✓ | ✓ | ✓ | ✓ | ✓ | ✓ | ✓ | ✓ | ✓ |
| ✓ | ✓ | ✓ | ✓ | ✓ | ✓ | ✓ | ✓ | ✓ | ✓ | ✓ | ✓ | ✓ |
| ✓ | ✓ | ✓ | ✓ | ✓ | ✓ | ✓ | ✓ | ✓ | ✓ | ✓ | ✓ | ✓ |
| <input type="checkbox"/> | <input type="checkbox"/> | <input type="checkbox"/> | <input type="checkbox"/> | <input type="checkbox"/> | <input type="checkbox"/> | <input type="checkbox"/> | <input type="checkbox"/> | <input type="checkbox"/> | <input type="checkbox"/> | <input type="checkbox"/> | <input type="checkbox"/> | <input type="checkbox"/> |
| ✓ | ✓ | ✓ | ✓ | ✓ | ✓ | ✓ | ✓ | ✓ | ✓ | ✓ | ✓ | ✓ |
| ✓ | ✓ | ✓ | ✓ | ✓ | ✓ | ✓ | ✓ | ✓ | ✓ | ✓ | ✓ | - |
| ✓ | ✓ | ✓ | ✓ | ✓ | ✓ | ✓ | ✓ | ✓ | ✓ | ✓ | ✓ | ✓ |
| ✓ | ✓ | ✓ | ✓ | ✓ | ✓ | - | - | - | - | - | - | - |
| ◇ | ◇ | ◇ | ◇ 2, 3 □ 4, 5 | ◇ 2, 3 □ 4, 5 | ◇ 2, 3 □ 4, 5 | <input type="checkbox"/> | <input type="checkbox"/> | <input type="checkbox"/> | <input type="checkbox"/> | <input type="checkbox"/> | <input type="checkbox"/> | <input type="checkbox"/> |
| ✓ - 4, 5 | ✓ - 4, 5 | ✓ - 4, 5 | ✓ - 4, 5 | ✓ - 4, 5 | ✓ - 4, 5 | - | - | - | - | - | - | - |
| ✓ | ✓ | ✓ | ✓ | ✓ | ✓ | ✓ | ✓ | ✓ | ✓ | ✓ | ✓ | ✓ |
| ✓ | ✓ | ✓ | ✓ | ✓ | ✓ | ✓ | ✓ | ✓ | ✓ | ✓ | ✓ | ✓ |
| ✓ | ✓ | ✓ | ✓ 2, 3, 4 □ 5 | ✓ 2, 3, 4 □ 5 | ✓ 2, 3, 4 □ 5 | ✓ 4 □ 5 | ✓ 4 □ 5 | ✓ 4 □ 5 | ✓ 4 □ 5 | ✓ 4 □ 5 | ✓ 4 □ 5 | ✓ 4 □ 5 |
| - | - | ✓ | ✓ 2, 3, 4 □ 5 (b) | ✓ 2, 3, 4 □ 5 (b) | ✓ 2, 3, 4 □ 5 (b) | ✓ | ✓ | ✓ | ✓ | ✓ | ✓ | ✓ |
| - | - | ✓ | ✓ | ✓ | ✓ | ✓ | ✓ | ✓ | ✓ | □ | □ | □ |
| ✓ □ 4, 5 | ✓ □ 4, 5 | ✓ □ 4, 5 | ✓ □ 4, 5 | ✓ □ 4, 5 | ✓ □ 4, 5 | <input type="checkbox"/> | <input type="checkbox"/> | <input type="checkbox"/> | <input type="checkbox"/> | <input type="checkbox"/> | <input type="checkbox"/> | <input type="checkbox"/> |
| ✓ | ✓ | ✓ | ✓ | ✓ | ✓ | ✓ | ✓ | ✓ | ✓ | ✓ | ✓ | ✓ |
| □ (c) | □ (c) | □ (c) | □ (c) | □ (c) | □ (c) | □ (c) | □ (c) | □ (c) | □ (c) | □ (c) | □ (c) | □ (c) |
| □ | □ | □ | □ | □ | □ | □ | □ | □ | □ | □ | □ | □ |

Motor selection and order number structure · 16 digits

Overview

The order number consists of a combination of figures and letters and is divided into three blocks linked with hyphens for a better overview.

The first block (Position 1 to 7) identifies the motor type and efficiency level; the second block (Position 8 to 12)

defines the motor frame size and length, the number of poles and in some cases the frequency/output; and in the third block (Position 13 to 16) the frequency/output, type of construction and other design features are encoded.

Structure of Order No. (1LE0 and 1LE10 series)

| Structure | Position: | 1 | 2 | 3 | 4 | 5 | 6 | 7 | - | 8 | 9 | 10 | 11 | 12 | - | 13 | 14 | 15 | 16 | - | Z | |
|----------------------------|--|---|---|---|---|---|---|---|---|---|---|----|----|----|---|----|----|----|----|---|---|--|
| Position 1 to 6: | Low-voltage motor series | | | | | | | | | | | | | | | | | | | | | |
| | • Cast Iron / made in China | 1 | L | E | 0 | 1 | 0 | | | | | | | | | | | | | | | |
| | • Aluminum | 1 | L | E | 1 | 0 | 0 | | | | | | | | | | | | | | | |
| Position 7: | Motor efficiency | | | | | | | | | | | | | | | | | | | | | |
| | • Motor with high efficiency - IE2 | | | | | | | 1 | | | | | | | | | | | | | | |
| | • Motor with improved efficiency - IE1 | | | | | | | 2 | | | | | | | | | | | | | | |
| Position 8 and 9: | Frame size | | | | | | | | | | | | | | | | | | | | | |
| | • 0D = 080; 0E = 090 | | | | | | | | | | | | | | | | | | | | | |
| | • 1A = 100; 1B = 112; 1C = 132; 1D = 160; 1E = 180 | | | | | | | | | | | | | | | | | | | | | |
| | • 2A = 200; 2B = 225; 2C = 250; 2D = 280 | | | | | | | | | | | | | | | | | | | | | |
| | • 3A = 315; 3B = 355 | | | | | | | | | | | | | | | | | | | | | |
| Position 10: | Number of poles | | | | | | | | | | | | | | | | | | | | | |
| | • A = 2; B = 4; C = 6 | | | | | | | | | | | | | | | | | | | | | |
| Position 11: | Frame length | | | | | | | | | | | | | | | | | | | | | |
| | • 0 or 1 = S (short) | | | | | | | | | | | | | | | | | | | | | |
| | • 2 or 3 = M (medium) | | | | | | | | | | | | | | | | | | | | | |
| | • 4, 5, 6 or 7 = L (long) ^(a) | | | | | | | | | | | | | | | | | | | | | |
| Position 12 and 13: | Voltage, circuit and frequency | | | | | | | | | | | | | | | | | | | | | |
| | • 22 = 230 VΔ 50 Hz | | | | | | | | | | | | | | | | | | | | | |
| | • 34 = 400 VΔ 50 Hz | | | | | | | | | | | | | | | | | | | | | |
| | • 33 = 380 VΔ 50 Hz | | | | | | | | | | | | | | | | | | | | | |
| | • 35 = 415 VΔ 50 Hz | | | | | | | | | | | | | | | | | | | | | |
| | • 41 = 525 VΔ 50 Hz | | | | | | | | | | | | | | | | | | | | | |
| | • 90 ^(b) = special voltage & frequency | | | | | | | | | | | | | | | | | | | | | |
| Position 14: | Type of construction | | | | | | | | | | | | | | | | | | | | | |
| | • A = IM B3 | | | | | | | | | | | | | | | | | | | | | |
| | • J = IM B35 | | | | | | | | | | | | | | | | | | | | | |
| | • F = IM B5 | | | | | | | | | | | | | | | | | | | | | |
| | • G = IM V1 | | | | | | | | | | | | | | | | | | | | | |
| | • K = IM B14 | | | | | | | | | | | | | | | | | | | | | |
| Position 15: | Motor protection | | | | | | | | | | | | | | | | | | | | | |
| | • A = without winding protection | | | | | | | | | | | | | | | | | | | | | |
| | • B = 3 PTC thermistors for tripping | | | | | | | | | | | | | | | | | | | | | |
| Position 16: | Terminal box location (view from drive end) | | | | | | | | | | | | | | | | | | | | | |
| | • 4 = terminal box on top | | | | | | | | | | | | | | | | | | | | | |
| | Special order version | | | | | | | | | | | | | | | | | | | | | |
| | Coded - Order (option) code also required ^(b) | | | | | | | | | | | | | | | | | | | | | |

^(a) For 1LE0 FS315 and 355 motors, digit 4 still stands for Medium (M).

^(b) For deviations in the second and third block from the catalog codes, either -Z or 90 should be used as appropriate, e.g. 1LE0101-1DB23-4AB4-Z Z=B02; or 1LE0101-1DB29-0AB4-Z Z=L1R.

Ordering example

| Selection criteria | Requirement | Structure of the Order No. |
|---|--|----------------------------|
| Motor type | Cast Iron motor with IP55 degree of protection | 1LE010-■■■■■■-■■■■■ |
| Efficiency | High efficiency IE2 | 1LE0101-■■■■■■-■■■■■ |
| Motor frame size / No. of poles / Speed | 160 / 4-pole / 1500 rpm | 1LE0101-1DB2-■■■■■ |
| Rated output | 11 kW | 1LE0101-1DB23-4■■■■■ |
| Voltage and frequency | 400 V, 50 Hz | 1LE0101-1DB23-4■■■■■ |
| Type of construction | IM B3 | 1LE0101-1DB23-4A■■■■■ |
| Motor protection | 3 PTC thermistors | 1LE0101-1DB23-4AB■■■■■ |
| Mechanical design | Terminal box on top | 1LE0101-1DB23-4AB4 |
| Special versions | Anti-condensation heating for 230 V | 1LE0101-1DB23-4AB4-Z Q02 |

Motor selection and order number structure · 12 digits

Overview

The order number consists of a combination of figures and letters and is divided into two blocks linked with hyphens for a better overview.

The first block (Position 1 to 7) identifies motor type and motor frame size; and the second block defines number of poles, frequency/output and type of construction.

Structure of Order No. (1LA7 series)

| Structure | Position: 1 2 3 4 5 6 7 - 8 9 10 11 12 - Z |
|--------------------------|---|
| <u>Position 1 to 4:</u> | Low-voltage motor series • IE1 Aluminum motor 1 L A 7 |
| <u>Position 5 to 7:</u> | Frame size (frame size comprising shaft height and construction length) • 060 • 063 • 070 • 073 • 080 • 083 • 090 • 096 |
| <u>Position 8:</u> | Number of poles • 2 • 4 • 6 |
| <u>Position 9 to 10:</u> | Version • AA • AB |
| <u>Position 11:</u> | Voltage, circuit and frequency • 6 = 400 VΔ 50 Hz • 9 ^(a) = special voltage & frequency ^(b) |
| <u>Position 12:</u> | Type of construction • 0 = IM B3 • 6 = IM B35 • 1 = IM B5 • 1 = IM V1 • 2 = IM B14 |
| | Special order version Coded - Order (option) code also required ^(a) |

^(a) For deviations in the second and third block from the catalog codes, either **-Z** or **9** should be used as appropriate, e.g. 1LA7080-2AA60-Z Z=B02; or 1LA7080-2AA90 Z=L1C.

^(b) L1L for 380 V, 50 Hz; L1C for 415 V, 50 Hz.

Ordering example

| Selection criteria | Requirement | Structure of the Order No. |
|---|-------------------------------------|----------------------------|
| Motor type | Aluminum motor IE1 efficiency | 1LA7■■■■■■■■■■ |
| Motor frame size / No. of poles / Speed | 4-pole / 1500 rpm | 1LA7080-4AA■■■ |
| Rated output | 0.55 kW | 1LA7080-4AA6■ |
| Voltage and frequency | 400 V, 50 Hz | 1LA7080-4AA60 |
| Type of construction | IM B3 | 1LA7080-4AA60 |
| Special versions | Anti-condensation heating for 230 V | 1LA7080-4AA60-Z K45 |

Motor selection and order number

Name plates

1LA7 series

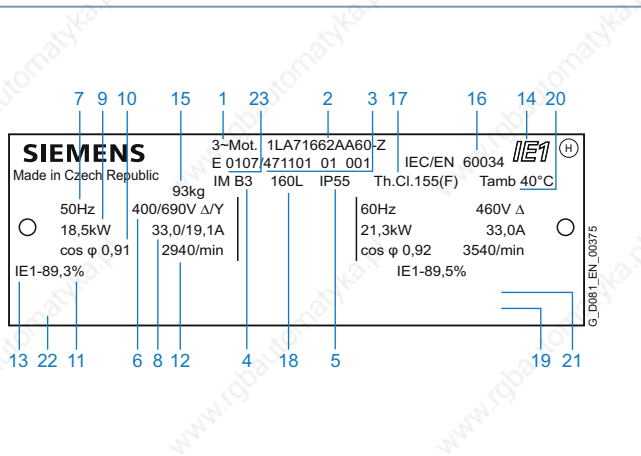

Legend:

- | | |
|---|--|
| 1 Three-phase low-voltage motor | 13 Efficiency class |
| 2 Order No. | 14 Balance method and efficiency class |
| 3 Factory number (Ident No., serial number) | 15 Machine weight [kg] |
| 4 Type of construction | 16 Standards and regulations |
| 5 Degree of protection | 17 Temperature class |
| 6 Rated voltage [V] and winding connections | 18 Frame size |
| 7 Frequency [Hz] | 19 Additional details (optional) |
| 8 Rated current [A] | 20 Operating temperature range (only if it deviates from normal) |
| 9 Rated output [kW] | 21 Site altitude (only when higher than 1000 m) |
| 10 Power factor [cos φ] | 22 Customer data (optional) |
| 11 Efficiency | 23 Date of manufacture YYMM |
| 12 Rated speed [rpm] | |

1LE10 series

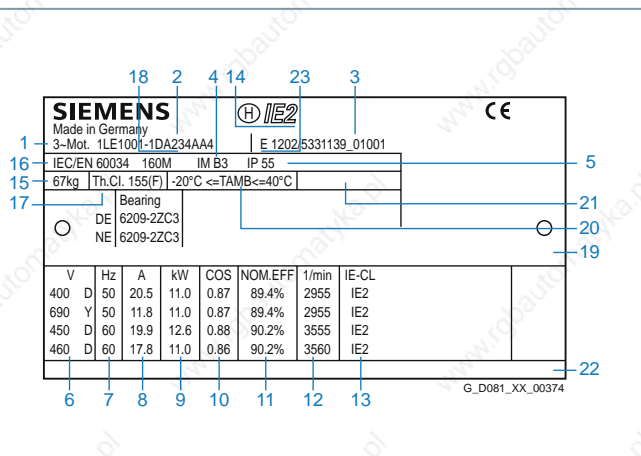

Legend:

- | | |
|---|--|
| 1 Three-phase low-voltage motor | 13 Efficiency class |
| 2 Order No. | 14 Balance method and efficiency class |
| 3 Factory number (Ident No., serial number) | 15 Machine weight [kg] |
| 4 Type of construction | 16 Standards and regulations |
| 5 Degree of protection | 17 Temperature class |
| 6 Rated voltage [V] and winding connections | 18 Frame size |
| 7 Frequency [Hz] | 19 Additional details (optional) |
| 8 Rated current [A] | 20 Operating temperature range (only if it deviates from normal) |
| 9 Rated output [kW] | 21 Site altitude (only when higher than 1000 m) |
| 10 Power factor [cos φ] | 22 Customer data (optional) |
| 11 Efficiency | 23 Date of manufacture YYMM |
| 12 Rated speed [rpm] | |

1LE0 series

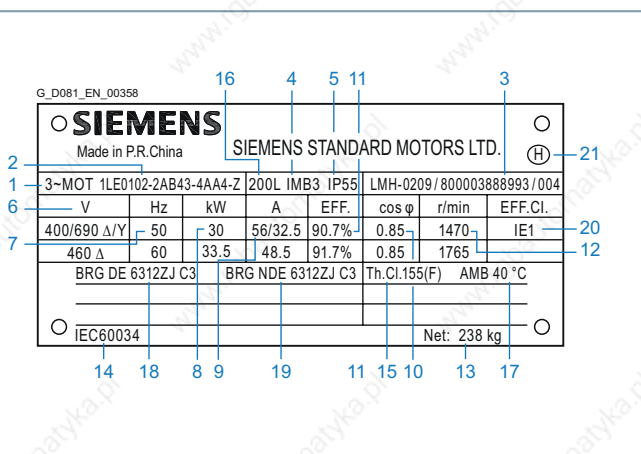

Legend:



- | | |
|---------------------------------|-----------------------------|
| 1 Three-phase low-voltage motor | 12 Rated speed |
| 2 Order No. | 13 Machine weight (kg) |
| 3 Series number | 14 Standards |
| 4 Type of construction | 15 Temperature class |
| 5 Degree of protection | 16 Frame size |
| 6 Rated voltage | 17 Ambient temperature |
| 7 Frequency (Hz) | 18 Bearing at drive end |
| 8 Rated output (kW) | 19 Bearing at non-drive end |
| 9 Rated current (A) | 20 Efficiency class |
| 10 Power factor (cos φ) | 21 Balance method |
| 11 Efficiency | |

Type of construction

In addition to the basic IM B3 type of construction, motors can also be supplied in other types of construction. We provide most commonly used type of constructions in our selection for you, as well as possibility for own modification.

The possible versions in our selection for a particular motor type can be taken from the table below.

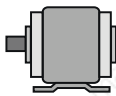
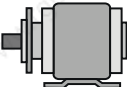
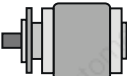
Standard type of construction and special type of construction

| Type of construction according to DIN EN 60034-7 | Frame size | 16 Digits Order No. 14th position of the Order No. | 12 Digits Order No. 12th position of the Order No. |
|--|---|--|--|
| IM B3 |  63 to 355 | A | 0 |
| IM B35 |  63 to 355 | J | 6 |
| IM B5 |  63 to 315 | F | 1 |
| IM V1 |  63 to 355 | G | 1 |
| IM B14 |  63 to 160 | K | 2 |

Did you know

















When mounting the motors in diverse orientations consider the location of the drain hole – it must be at the lowest point to drain water.

Apart from the distribution portfolio covered mounting types, here is the general overview of the possible mounting types. Many of them can be achieved by modifying this offered portfolio. Anything else can still be supplied out of our standard catalog portfolio, see D81.1

TIP

Mounting motors in orientations other than these intended could lead to mechanical or structural premature failure. If in any doubt, please consult your Siemens partner.

Types of construction

| | | | | | | | | |
|---|---|---|---|---|---|--|--|--|
|  IM B3 |  IM B6 |  IM B7 |  IM B8 |  IM V5 |  IM V6 |  IM B14 |  IM V18 |  IM V19 |
|  IM B5 |  IM V1 |  IM V3 |  IM B9 |  IM V8 |  IM V9 |  IM B35 |  IM B34 | |

Types of construction according to DIN IEC 34, Part 7



The nominal torque of the motor is easy to calculate;
 Torque (Nm) =
 Power (kW) x 9550 / Speed (rpm).

SIMOTICS General Purpose (Aluminum Series) – IE1

| Aluminum Series | | | | | | | | | |
|-----------------------|--------------------------|---|---|--------------------------|---|---|--------------------------|---|---|
| Efficiency class | IE1 | | | | | | IE2 | | |
| Series | 1LA7 | | | 1LE1002 | | | 1LE1001 | | |
| No. of poles | 2 | 4 | 6 | 2 | 4 | 6 | 2 | 4 | 6 |
| Cooling | Self-ventilated (IC 411) | | | Self-ventilated (IC 411) | | | Self-ventilated (IC 411) | | |
| Degree of protection | IP55 | | | IP55 | | | IP55 | | |
| Insulation | Thermal class 155(F) | | | Thermal class 155(F) | | | Thermal class 155(F) | | |
| Utilization | Thermal class 130(B) | | | Thermal class 130(B) | | | Thermal class 130(B) | | |
| Frame size | 63 ... 90 | | | 100 ... 160 | | | 80 ... 160 | | |
| Rated output at 50 Hz | 0.09 ... 2.2 kW | | | 1.5 ... 18.5 kW | | | 0.37 ... 18.5 kW | | |
| Rated torque at 50 Hz | 0.61 ... 11 Nm | | | 10 ... 109 Nm | | | 2.6 ... 108 Nm | | |

| Electrical data - 1LA7 & 1LE10 - IE1 - 2-pole (IE1 Aluminum) 3000 rpm 2-pole, 400 V 50 Hz | | | | | | | | | | | | | | | | | |
|---|------------|------------------|----------|--------------|------|----------------------|--------------------|--------------------|---------------|------------|------------|-----------------|-----|-------------------------|---------------------------------------|--------------|-------------------------|
| Rated output kW | Frame size | Order number | IE class | Rated torque | | No load current A | Rated current A | Rated power factor | Efficiency at | | | Starting torque | | Break-down torque Nm | Moment of inertia kgm ² | Torque class | Net weight (IMB3) kg |
| | | | | speed rpm | Nm | | | | 100% load % | 75% load % | 50% load % | current A | Nm | | | | |
| 0.18 | 63M | 1LA7060-2AA.. | - | 2820 | 0.61 | 0.43 | 0.51 | 0.82 | 62.0 | 60.5 | 56.0 | 3.7 | 2.0 | 2.2 | 0.00018 | 16 | 3.6 |
| 0.25 | 63M | 1LA7063-2AA.. | - | 2830 | 0.84 | 0.60 | 0.70 | 0.82 | 63.0 | 62.0 | 57.0 | 4.0 | 2.3 | 2.2 | 0.00022 | 16 | 4.0 |
| 0.37 | 71M | 1LA7070-2AA.. | - | 2740 | 1.3 | 0.86 | 0.99 | 0.82 | 66.0 | 65.0 | 61.0 | 3.5 | 2.5 | 2.3 | 0.00029 | 16 | 5.0 |
| 0.55 | 71M | 1LA7073-2AA.. | - | 2800 | 1.9 | 1.12 | 1.36 | 0.82 | 71.0 | 71.0 | 67.0 | 4.3 | 2.3 | 2.6 | 0.00041 | 16 | 6.0 |
| 0.75 | 80M | 1LA7080-2AA.. | IE 1 | 2855 | 2.5 | 1.34 | 1.75 | 0.86 | 72.1 | 72.1 | 68.1 | 5.6 | 2.6 | 2.4 | 0.00079 | 16 | 9.0 |
| 1.1 | 80M | 1LA7083-2AA.. | IE 1 | 2845 | 3.7 | 1.47 | 2.45 | 0.87 | 75.0 | 75.0 | 72.0 | 6.1 | 2.4 | 2.7 | 0.0010 | 16 | 10.7 |
| 1.5 | 90S | 1LA7090-2AA.. | IE 1 | 2860 | 5.0 | 2.10 | 3.3 | 0.85 | 77.2 | 77.7 | 74.2 | 5.5 | 2.8 | 2.7 | 0.0014 | 16 | 13.0 |
| 2.2 | 90L | 1LA7096-2AA.. | IE 1 | 2880 | 7.3 | 2.30 | 4.7 | 0.85 | 79.7 | 79.7 | 78.7 | 6.3 | 2.8 | 3.1 | 0.0018 | 16 | 15.7 |
| 3 | 100L | 1LE1002-1AA4...4 | IE 1 | 2835 | 10 | 2.77 | 6.1 | 0.87 | 81.5 | 82.8 | 82.1 | 6.2 | 3.2 | 2.9 | 0.0034 | 16 | 20 |
| 4 | 112M | 1LE1002-1BA2...4 | IE 1 | 2930 | 13 | 4.15 | 8.1 | 0.86 | 83.1 | 83.8 | 82.2 | 7.3 | 2.7 | 3.7 | 0.0067 | 16 | 25 |
| 5.5 | 132S | 1LE1002-1CA0...4 | IE 1 | 2905 | 18 | 4.37 | 10.5 | 0.89 | 84.7 | 85.7 | 85.0 | 5.6 | 1.9 | 2.5 | 0.013 | 16 | 35 |
| 7.5 | 132S | 1LE1002-1CA1...4 | IE 1 | 2925 | 24 | 6.1 | 14.5 | 0.87 | 86.0 | 86.9 | 85.8 | 6.3 | 2.1 | 3.2 | 0.016 | 16 | 40 |
| 11 | 160M | 1LE1002-1DA2...4 | IE 1 | 2925 | 36 | 9.13 | 21.5 | 0.85 | 87.6 | 87.6 | 86.1 | 5.8 | 2.0 | 2.6 | 0.030 | 16 | 60 |
| 15 | 160M | 1LE1002-1DA3...4 | IE 1 | 2930 | 49 | 12.4 | 29 | 0.84 | 88.7 | 89.0 | 88.0 | 6.1 | 2.5 | 3.1 | 0.036 | 16 | 68 |
| 18.5 | 160L | 1LE1002-1DA4...4 | IE 1 | 2935 | 60 | 13.38 | 35 | 0.86 | 89.3 | 90.0 | 89.7 | 7.0 | 2.5 | 3.2 | 0.044 | 16 | 78 |

| Electrical data - 1LA7 & 1LE10 - IE1 - 4-pole (IE1 Aluminum) 1500 rpm 4-pole, 400 V 50 Hz | | | | | | | | | | | | | | | | | |
|---|------------|------------------|----------|--------------|------|----------------------|--------------------|--------------------|---------------|------------|------------|-----------------|-----|-------------------------|---------------------------------------|--------------|-------------------------|
| Rated output kW | Frame size | Order number | IE class | Rated torque | | No load current A | Rated current A | Rated power factor | Efficiency at | | | Starting torque | | Break-down torque Nm | Moment of inertia kgm ² | Torque class | Net weight (IMB3) kg |
| | | | | speed rpm | Nm | | | | 100% load % | 75% load % | 50% load % | current A | Nm | | | | |
| 0.12 | 63M | 1LA7060-4AB.. | - | 1350 | 0.85 | 0.40 | 0.43 | 0.75 | 53.6 | 52.1 | 47.6 | 2.8 | 1.9 | 2.0 | 0.00029 | 13 | 3.6 |
| 0.18 | 63M | 1LA7063-4AB.. | - | 1350 | 1.3 | 0.52 | 0.58 | 0.77 | 58.3 | 56.8 | 52.3 | 3.0 | 1.9 | 1.9 | 0.00037 | 13 | 4.0 |
| 0.25 | 71M | 1LA7070-4AB.. | - | 1350 | 1.8 | 0.72 | 0.75 | 0.78 | 61.9 | 60.4 | 55.9 | 3.0 | 1.9 | 1.9 | 0.00052 | 13 | 4.8 |
| 0.37 | 71M | 1LA7073-4AB.. | - | 1370 | 2.6 | 0.93 | 1.04 | 0.78 | 65.8 | 64.8 | 60.8 | 3.3 | 1.9 | 2.1 | 0.00077 | 13 | 6.3 |
| 0.55 | 80M | 1LA7080-4AA.. | - | 1395 | 3.8 | 1.30 | 1.41 | 0.81 | 69.4 | 69.4 | 65.4 | 3.9 | 2.2 | 2.2 | 0.0014 | 16 | 8.8 |
| 0.75 | 80M | 1LA7083-4AA.. | IE 1 | 1395 | 5.1 | 1.57 | 1.88 | 0.80 | 72.1 | 72.1 | 68.1 | 4.2 | 2.3 | 2.3 | 0.0017 | 16 | 10.0 |
| 1.1 | 90S | 1LA7090-4AA.. | IE 1 | 1415 | 7.4 | 2.00 | 2.6 | 0.81 | 75.0 | 75.0 | 72.0 | 4.6 | 2.3 | 2.4 | 0.0024 | 16 | 12.9 |
| 1.5 | 90L | 1LA7096-4AA.. | IE 1 | 1420 | 10 | 2.65 | 3.45 | 0.81 | 77.2 | 77.7 | 74.2 | 5.3 | 2.4 | 2.6 | 0.0033 | 16 | 15.5 |
| 2.2 | 100L | 1LE1002-1AB4...4 | IE 1 | 1425 | 15 | 2.36 | 4.9 | 0.81 | 79.7 | 80.5 | 78.5 | 5.1 | 2.2 | 2.3 | 0.0059 | 16 | 18 |
| 3 | 100L | 1LE1002-1AB5...4 | IE 1 | 1425 | 20 | 3.11 | 6.3 | 0.85 | 81.5 | 83 | 82.3 | 5.4 | 2.4 | 2.6 | 0.0078 | 16 | 22 |
| 4 | 112M | 1LE1002-1BB2...4 | IE 1 | 1435 | 27 | 4.04 | 8.2 | 0.85 | 83.1 | 84.5 | 84 | 5.3 | 2.2 | 2.6 | 0.01 | 16 | 27 |
| 5.5 | 132S | 1LE1002-1CB0...4 | IE 1 | 1450 | 36 | 6.04 | 11.2 | 0.82 | 84.7 | 85.7 | 84.9 | 5.7 | 2.3 | 2.7 | 0.019 | 16 | 38 |
| 7.5 | 132M | 1LE1002-1CB2...4 | IE 1 | 1450 | 49 | 7.94 | 15.2 | 0.82 | 86 | 86.9 | 86.3 | 6.6 | 2.6 | 3.1 | 0.024 | 16 | 44 |
| 11 | 160M | 1LE1002-1DB2...4 | IE 1 | 1460 | 72 | 12.40 | 22 | 0.82 | 87.6 | 88 | 86.6 | 6.4 | 2.3 | 3.1 | 0.044 | 16 | 62 |
| 15 | 160L | 1LE1002-1DB4...4 | IE 1 | 1460 | 98 | 15.90 | 30 | 0.82 | 88.7 | 89.3 | 88.3 | 7 | 2.5 | 3.4 | 0.056 | 16 | 73 |

| Electrical data - 1LA7 & 1LE10 - IE1 - 6-pole (IE1 Aluminum) 1000 rpm 6-pole, 400 V 50 Hz | | | | | | | | | | | | | | | | | |
|---|------------|------------------|----------|--------------|------|----------------------|--------------------|--------------------|---------------|------------|------------|-----------------|-----|-------------------------|---------------------------------------|--------------|-------------------------|
| Rated output kW | Frame size | Order number | IE class | Rated torque | | No load current A | Rated current A | Rated power factor | Efficiency at | | | Starting torque | | Break-down torque Nm | Moment of inertia kgm ² | Torque class | Net weight (IMB3) kg |
| | | | | speed rpm | Nm | | | | 100% load % | 75% load % | 50% load % | current A | Nm | | | | |
| 0.09 | 63M | 1LA7063-6AB.. | - | 850 | 1.0 | 0.46 | 0.39 | 0.66 | 50.2 | 48.7 | 44.2 | 2.0 | 1.8 | 1.9 | 0.00037 | 13 | 4.0 |
| 0.18 | 71M | 1LA7070-6AA.. | - | 850 | 2.0 | 0.65 | 0.67 | 0.68 | 57.3 | 55.8 | 51.3 | 2.3 | 2.1 | 1.9 | 0.00055 | 16 | 4.8 |
| 0.25 | 71M | 1LA7073-6AA.. | - | 860 | 2.8 | 0.71 | 0.77 | 0.76 | 61.9 | 60.4 | 55.9 | 2.7 | 2.2 | 2.0 | 0.00080 | 16 | 5.8 |
| 0.37 | 80M | 1LA7080-6AA.. | - | 920 | 3.8 | 1.18 | 1.16 | 0.72 | 64.1 | 63.1 | 59.1 | 3.1 | 1.9 | 2.1 | 0.0014 | 16 | 8.6 |
| 0.55 | 80M | 1LA7083-6AA.. | - | 910 | 5.8 | 1.45 | 1.59 | 0.74 | 67.5 | 67.0 | 63.5 | 3.4 | 2.1 | 2.2 | 0.0017 | 16 | 9.8 |
| 0.75 | 90S | 1LA7090-6AA.. | IE 1 | 915 | 7.8 | 1.63 | 2.05 | 0.76 | 70.0 | 70.0 | 66.0 | 3.7 | 2.2 | 2.2 | 0.0024 | 16 | 12.6 |
| 1.1 | 90L | 1LA7096-6AA.. | IE 1 | 915 | 11.0 | 2.15 | 2.85 | 0.77 | 72.9 | 72.9 | 69.9 | 3.8 | 2.3 | 2.3 | 0.0033 | 16 | 15.7 |
| 1.5 | 100L | 1LE1002-1AC4...4 | IE 1 | 940 | 15 | 2.66 | 3.9 | 0.74 | 75.2 | 76 | 72.4 | 4 | 2 | 2.2 | 0.0065 | 16 | 19 |
| 2.2 | 112M | 1LE1002-1BC2...4 | IE 1 | 930 | 23 | 3.43 | 5.4 | 0.75 | 77.7 | 78.8 | 76.9 | 4.1 | 2.3 | 2.5 | 0.0092 | 16 | 25 |
| 3 | 132S | 1LE1002-1CC0...4 | IE 1 | 955 | 30 | 4.86 | 7.3 | 0.74 | 79.7 | 80.2 | 77.7 | 4.6 | 2 | 2.6 | 0.017 | 16 | 34 |
| 4 | 132M | 1LE1002-1CC2...4 | IE 1 | 950 | 40 | 5.47 | 9.3 | 0.76 | 81.4 | 82.9 | 82.1 | 4.7 | 2.1 | 2.5 | 0.021 | 16 | 39 |
| 5.5 | 132M | 1LE1002-1CC3...4 | IE 1 | 950 | 55 | 7.59 | 12.7 | 0.75 | 83.1 | 84.6 | 84 | 5.2 | 2.5 | 2.8 | 0.027 | 16 | 48 |
| 7.5 | 160M | 1LE1002-1DC2...4 | IE 1 | 970 | 74 | 10.73 | 17.5 | 0.73 | 84.7 | 85.4 | 85 | 5.5 | 2.1 | 2.9 | 0.056 | 16 | 72 |
| 11 | 160L | 1LE1002-1DC4...4 | IE 1 | 965 | 109 | 13.10 | 24 | 0.77 | 86.4 | 86.4 | 85.4 | 5.9 | 1.9 | 2.7 | 0.078 | 16 | 92 |

SIMOTICS General Purpose (Aluminum Series) – IE2

| | | Aluminum Series | | | | | | | | |
|-----------------------|--|--------------------------|---|---|--------------------------|---|---|--------------------------|---|---|
| Efficiency class | | IE1 | | | | | | IE2 | | |
| Series | | 1LA7 | | | 1LE1002 | | | 1LE1001 | | |
| No. of poles | | 2 | 4 | 6 | 2 | 4 | 6 | 2 | 4 | 6 |
| Cooling | | Self-ventilated (IC 411) | | | Self-ventilated (IC 411) | | | Self-ventilated (IC 411) | | |
| Degree of protection | | IP55 | | | IP55 | | | IP55 | | |
| Insulation | | Thermal class 155(F) | | | Thermal class 155(F) | | | Thermal class 155(F) | | |
| Utilization | | Thermal class 130(B) | | | Thermal class 130(B) | | | Thermal class 130(B) | | |
| Frame size | | 63 ... 90 | | | 100 ... 160 | | | 80 ... 160 | | |
| Rated output at 50 Hz | | 0.09 ... 2.2 kW | | | 1.5 ... 18.5 kW | | | 0.37 ... 18.5 kW | | |
| Rated torque at 50 Hz | | 0.61 ... 11 Nm | | | 10 ... 109 Nm | | | 2.6 ... 108 Nm | | |

| Electrical data - 1LE10 - IE2 - 2-pole (IE2 Aluminum) 3000 rpm 2-pole, 400 V 50 Hz | | | | | | | | | | | | | | | | | |
|--|------------|-------------------|----------|--------------------|-----|----------------------|--------------------|--------------------|---------------|------------|------------|-------------------------|-----|-------------------------|---------------------------------------|--------------|-------------------------|
| Rated output kW | Frame size | Order number | IE class | Rated speed torque | | No load current A | Rated current A | Rated power factor | Efficiency at | | | Starting current torque | | Break-down torque Nm | Moment of inertia kgm ² | Torque class | Net weight (IMB3) kg |
| | | | | rpm | Nm | | | | 100% load % | 75% load % | 50% load % | current A | Nm | | | | |
| 0.75 | 80M | 1LE1001-0DA2-...4 | IE 2 | 2805 | 2.6 | 0.89 | 1.67 | 0.84 | 77.4 | 79.5 | 78.8 | 4.9 | 1.9 | 2.3 | 0.0008 | 16 | 9 |
| 1.1 | 80M | 1LE1001-0DA3-...4 | IE 2 | 2835 | 3.7 | 1.22 | 2.4 | 0.83 | 79.6 | 81.3 | 80.8 | 6 | 2.7 | 3.1 | 0.0011 | 16 | 11 |
| 1.5 | 90S | 1LE1001-0EA0-...4 | IE 2 | 2885 | 5 | 1.91 | 3.15 | 0.84 | 81.3 | 82.3 | 80.8 | 6.9 | 2.7 | 3.6 | 0.0017 | 16 | 13 |
| 2.2 | 90L | 1LE1001-0EA4-...4 | IE 2 | 2890 | 7.3 | 2.45 | 4.5 | 0.85 | 83.2 | 83.9 | 82.3 | 7.1 | 2.5 | 3.7 | 0.0021 | 16 | 15 |
| 3 | 100L | 1LE1001-1AA4-...4 | IE 2 | 2905 | 9.9 | 3.3 | 6.1 | 0.84 | 84.6 | 85.2 | 84.7 | 7 | 2.3 | 3.3 | 0.0044 | 16 | 21 |
| 4 | 112M | 1LE1001-1BA2-...4 | IE 2 | 2950 | 13 | 3.7 | 7.8 | 0.86 | 85.8 | 86.7 | 86.1 | 7.4 | 2.4 | 3.3 | 0.0092 | 16 | 27 |
| 5.5 | 132S | 1LE1001-1CA0-...4 | IE 2 | 2950 | 18 | 4.3 | 10.5 | 0.87 | 87 | 88 | 87.4 | 6.6 | 1.8 | 2.9 | 0.02 | 16 | 39 |
| 7.5 | 132S | 1LE1001-1CA1-...4 | IE 2 | 2950 | 24 | 5.7 | 14.1 | 0.87 | 88.1 | 88.7 | 88.6 | 7.5 | 2.2 | 3.1 | 0.024 | 16 | 43 |
| 11 | 160M | 1LE1001-1DA2-...4 | IE 2 | 2955 | 36 | 8.4 | 20.5 | 0.87 | 89.4 | 90 | 89.1 | 7.4 | 2.1 | 3.2 | 0.045 | 16 | 67 |
| 15 | 160M | 1LE1001-1DA3-...4 | IE 2 | 2955 | 48 | 10.6 | 27 | 0.88 | 90.3 | 90.9 | 90.3 | 7.6 | 2.4 | 3.4 | 0.053 | 16 | 75 |
| 18.5 | 160L | 1LE1001-1DA4-...4 | IE 2 | 2955 | 60 | 13 | 33.5 | 0.88 | 90.9 | 91.2 | 90.4 | 7.9 | 2.9 | 3.6 | 0.061 | 16 | 84 |

| Electrical data - 1LE10 - IE2 - 4-pole (IE2 Aluminum) 1500 rpm 4-pole, 400 V 50 Hz | | | | | | | | | | | | | | | | | |
|--|------------|-------------------|----------|--------------------|-----|----------------------|--------------------|--------------------|---------------|------------|------------|-------------------------|-----|-------------------------|---------------------------------------|--------------|-------------------------|
| Rated output kW | Frame size | Order number | IE class | Rated speed torque | | No load current A | Rated current A | Rated power factor | Efficiency at | | | Starting current torque | | Break-down torque Nm | Moment of inertia kgm ² | Torque class | Net weight (IMB3) kg |
| | | | | rpm | Nm | | | | 100% load % | 75% load % | 50% load % | current A | Nm | | | | |
| 0.55 | 80M | 1LE1001-0DB2-...4 | - | 1440 | 3.7 | 0.99 | 1.37 | 0.74 | 78.1 | 78.9 | 76.1 | 5.3 | 2.2 | 3.1 | 0.0017 | 16 | 10 |
| 0.75 | 80M | 1LE1001-0DB3-...4 | IE 2 | 1440 | 5 | 1.21 | 1.79 | 0.76 | 79.6 | 80.2 | 78 | 5.6 | 2.2 | 3.1 | 0.0021 | 16 | 11 |
| 1.1 | 90S | 1LE1001-0EB0-...4 | IE 2 | 1425 | 7.4 | 1.7 | 2.5 | 0.78 | 81.4 | 81.7 | 79.9 | 5.6 | 2.3 | 2.9 | 0.0028 | 16 | 13 |
| 1.5 | 90L | 1LE1001-0EB4-...4 | IE 2 | 1435 | 10 | 2.1 | 3.3 | 0.79 | 82.8 | 83.5 | 82 | 6.4 | 2.6 | 3.4 | 0.0036 | 16 | 16 |
| 2.2 | 100L | 1LE1001-1AB4-...4 | IE 2 | 1455 | 14 | 2.6 | 4.65 | 0.81 | 84.3 | 85.1 | 84.3 | 6.9 | 2.1 | 3.3 | 0.0086 | 16 | 21 |
| 3 | 100L | 1LE1001-1AB5-...4 | IE 2 | 1455 | 20 | 3.35 | 6.2 | 0.82 | 85.5 | 86.7 | 86 | 6.9 | 2 | 3.1 | 0.011 | 16 | 25 |
| 4 | 112M | 1LE1001-1BB2-...4 | IE 2 | 1460 | 26 | 4.3 | 8.2 | 0.81 | 86.6 | 87.3 | 86.5 | 7.1 | 2.5 | 3.2 | 0.014 | 16 | 29 |
| 5.5 | 132S | 1LE1001-1CB0-...4 | IE 2 | 1465 | 36 | 5.7 | 11.3 | 0.8 | 87.7 | 89 | 87.7 | 6.9 | 2.3 | 2.9 | 0.027 | 16 | 42 |
| 7.5 | 132M | 1LE1001-1CB2-...4 | IE 2 | 1465 | 49 | 6.5 | 14.7 | 0.83 | 88.7 | 90.3 | 88.8 | 6.9 | 2.3 | 2.9 | 0.034 | 16 | 49 |
| 11 | 160M | 1LE1001-1DB2-...4 | IE 2 | 1470 | 71 | 8.7 | 21 | 0.85 | 89.8 | 90.9 | 90.8 | 6.7 | 2.1 | 2.8 | 0.065 | 16 | 71 |
| 15 | 160L | 1LE1001-1DB4-...4 | IE 2 | 1475 | 97 | 11.3 | 28 | 0.85 | 90.6 | 91.3 | 91 | 7.3 | 2.3 | 3 | 0.083 | 16 | 83 |

| Electrical data - 1LE10 - IE2 - 6-pole (IE2 Aluminum) 1000 rpm 6-pole, 400 V 50 Hz | | | | | | | | | | | | | | | | | |
|--|------------|-------------------|----------|--------------------|------|----------------------|--------------------|--------------------|---------------|------------|------------|-------------------------|-----|-------------------------|---------------------------------------|--------------|-------------------------|
| Rated output kW | Frame size | Order number | IE class | Rated speed torque | | No load current A | Rated current A | Rated power factor | Efficiency at | | | Starting current torque | | Break-down torque Nm | Moment of inertia kgm ² | Torque class | Net weight (IMB3) kg |
| | | | | rpm | Nm | | | | 100% load % | 75% load % | 50% load % | current A | Nm | | | | |
| 0.37 | 80M | 1LE1001-0DC2-...4 | - | 925 | 3.85 | 0.81 | 1.08 | 0.69 | 71.4 | 71.5 | 66.5 | 4 | 2.1 | 2.4 | 0.001716 | 16 | 9 |
| 0.55 | 80M | 1LE1001-0DC3-...4 | - | 935 | 5.6 | 1.07 | 1.63 | 0.66 | 74 | 74 | 70.5 | 4.4 | 2.5 | 2.9 | 0.0025 | 16 | 12 |
| 0.75 | 90S | 1LE1001-0EC0-...4 | IE2 | 925 | 7.7 | 1.2 | 2.05 | 0.7 | 75.9 | 76 | 73 | 4.1 | 2 | 2.5 | 0.003 | 16 | 13 |
| 1.1 | 90L | 1LE1001-0EC4-...4 | IE2 | 935 | 11.2 | 1.93 | 2.9 | 0.7 | 78.1 | 78.5 | 75 | 4.4 | 2.2 | 2.6 | 0.004 | 16 | 16 |
| 1.5 | 100L | 1LE1001-1AC4-...4 | IE2 | 970 | 15 | 2.2 | 3.7 | 0.73 | 79.8 | 80.2 | 79 | 6.2 | 2 | 2.9 | 0.011 | 16 | 25 |
| 2.2 | 112M | 1LE1001-1BC2-...4 | IE2 | 965 | 22 | 2.9 | 5.2 | 0.75 | 81.8 | 82.5 | 81.3 | 6 | 2.1 | 3.1 | 0.014 | 16 | 29 |
| 3 | 132S | 1LE1001-1CC0-...4 | IE2 | 970 | 30 | 4.2 | 7 | 0.74 | 83.3 | 84 | 82.8 | 5.6 | 1.6 | 2.6 | 0.024 | 13 | 38 |
| 4 | 132M | 1LE1001-1CC2-...4 | IE2 | 970 | 39 | 4.5 | 8.7 | 0.78 | 84.6 | 85.8 | 85 | 5.6 | 1.6 | 2.5 | 0.029 | 13 | 43 |
| 5.5 | 132M | 1LE1001-1CC3-...4 | IE2 | 970 | 54 | 6.3 | 12 | 0.77 | 86 | 87.4 | 87 | 6.1 | 1.9 | 2.8 | 0.037 | 16 | 52 |
| 7.5 | 160M | 1LE1001-1DC2-...4 | IE2 | 975 | 73 | 8.25 | 16.1 | 0.77 | 87.2 | 87.7 | 86.9 | 6.3 | 1.8 | 2.8 | 0.075 | 16 | 77 |
| 11 | 160L | 1LE1001-1DC4-...4 | IE2 | 975 | 108 | 10.1 | 22.5 | 0.8 | 88.7 | 89.5 | 89.4 | 6.2 | 1.7 | 2.7 | 0.098 | 16 | 93 |



The nominal torque of the motor is easy to calculate;
 Torque (Nm) =
 Power (kW) x 9550 / Speed (rpm).

SIMOTICS General Purpose (Cast Iron) – IE1

| | Cast Iron Series | | | | | |
|-----------------------|--------------------------|---|---|--------------------------|---|---|
| Efficiency class | IE1 | | | IE2 | | |
| Series | 1LE0102 | | | 1LE0101 | | |
| No. of poles | 2 | 4 | 6 | 2 | 4 | 6 |
| Cooling | Self-ventilated (IC 411) | | | Self-ventilated (IC 411) | | |
| Degree of protection | IP55 | | | IP55 | | |
| Insulation | Thermal class 155(F) | | | Thermal class 155(F) | | |
| Utilization | Thermal class 130(B) | | | Thermal class 130(B) | | |
| Frame size | 80 ... 355 | | | 80 ... 355 | | |
| Rated output at 50 Hz | 0.55 ... 315 kW | | | 0.55 ... 315 kW | | |
| Rated torque at 50 Hz | 2.6 ... 2412 Nm | | | 2.6 ... 2412 Nm | | |

| Electrical data - 1LE0 - IE1 - 2-pole | | | | | | | | | | | | | | | | | |
|--|------------|-------------------|----------|-------------|--------------|-----------------|---------------|--------------------|---------------|------------|------------|------------------|-----------------|-------------------|-------------------|--------------|-------------------|
| (IE1 Cast Iron) 3000 rpm 2-pole, 400 V 50 Hz | | | | | | | | | | | | | | | | | |
| Rated output | Frame size | Order number | IE class | Rated speed | Rated torque | No load current | Rated current | Rated power factor | Efficiency at | | | Starting current | Starting torque | Break-down torque | Moment of inertia | Torque class | Net weight (IMB3) |
| kW | | | | rpm | Nm | A | A | | 100% load % | 75% load % | 50% load % | A | Nm | Nm | kgm ² | | kg |
| 230 V Δ / 400 VY | | | | | | | | | | | | | | | | | |
| 0.75 | 80M | 1LE0102-ODA22-2.4 | IE 1 | 2800 | 2.6 | 0.95 | 1.76 | 0.86 | 72.1 | 73.0 | 71.1 | 5.1 | 2.3 | 2.7 | 0.0008 | D | 15.0 |
| 1.1 | 80M | 1LE0102-ODA32-2.4 | IE 1 | 2830 | 3.7 | 1.16 | 2.50 | 0.86 | 75.0 | 77.3 | 74.4 | 6 | 2.6 | 3.1 | 0.001 | E | 17.5 |
| 1.5 | 90S | 1LE0102-OEA02-2.4 | IE 1 | 2885 | 5 | 1.82 | 3.30 | 0.85 | 77.2 | 76.9 | 73.5 | 6.9 | 2.5 | 3.2 | 0.0017 | F | 22 |
| 2.2 | 90L | 1LE0102-OEA42-2.4 | IE 1 | 2885 | 7.3 | 2.15 | 4.50 | 0.87 | 79.7 | 80.5 | 78.1 | 7.5 | 2.7 | 3.4 | 0.0022 | F | 26 |
| 3 | 100L | 1LE0102-1AA42-2.4 | IE 1 | 2850 | 10 | 2.80 | 6.3 | 0.85 | 81.5 | 82.1 | 79.9 | 6.9 | 3 | 3.7 | 0.0033 | F | 33 |
| 4 | 112M | 1LE0102-1BA22-2.4 | IE 1 | 2910 | 13.1 | 6.5 | 8.2 | 0.85 | 83.1 | 83.7 | 81.5 | 7.8 | 2.9 | 4.2 | 0.0064 | L | 39 |
| 5.5 | 132S | 1LE0102-1CA02-2.4 | IE 1 | 2915 | 18 | 8.0 | 10.9 | 0.86 | 84.7 | 85.3 | 83.7 | 6.9 | 2 | 3.1 | 0.013 | K | 55 |
| 7.5 | 132S | 1LE0102-1CA12-2.4 | IE 1 | 2920 | 24.5 | 11.3 | 14.3 | 0.88 | 86.0 | 87.2 | 86.2 | 7.1 | 2 | 2.9 | 0.015 | K | 60 |
| 400 V Δ / 690 VY | | | | | | | | | | | | | | | | | |
| 3 | 100L | 1LE0102-1AA43-4.4 | IE 1 | 2850 | 10 | 2.75 | 6.3 | 0.85 | 81.5 | 82.1 | 79.9 | 6.9 | 3 | 3.7 | 0.0033 | F | 33 |
| 4 | 112M | 1LE0102-1BA23-4.4 | IE 1 | 2910 | 13.1 | 3.80 | 8.2 | 0.85 | 83.1 | 83.7 | 81.5 | 7.8 | 2.9 | 4.2 | 0.0064 | L | 39 |
| 5.5 | 132S | 1LE0102-1CA03-4.4 | IE 1 | 2915 | 18 | 5.0 | 10.9 | 0.86 | 84.7 | 85.3 | 83.7 | 6.9 | 2 | 3.1 | 0.013 | K | 55 |
| 7.5 | 132S | 1LE0102-1CA13-4.4 | IE 1 | 2920 | 24.5 | 5.9 | 14.3 | 0.88 | 86.0 | 87.2 | 86.2 | 7.1 | 2 | 2.9 | 0.015 | K | 60 |
| 11 | 160M | 1LE0102-1DA23-4.4 | IE 1 | 2925 | 35.9 | 9.3 | 21.5 | 0.84 | 87.6 | 88.2 | 87.1 | 6.3 | 2 | 3.1 | 0.028 | J | 93 |
| 15 | 160M | 1LE0102-1DA33-4.4 | IE 1 | 2930 | 48.9 | 12.1 | 28.5 | 0.85 | 88.7 | 89.3 | 87.4 | 7 | 2.2 | 3.2 | 0.034 | K | 101 |
| 18.5 | 160L | 1LE0102-1DA43-4.4 | IE 1 | 2935 | 60 | 14.1 | 35.0 | 0.86 | 89.3 | 89.9 | 89.1 | 7.6 | 2.5 | 3.4 | 0.041 | K | 120 |
| 22 | 180M | 1LE0102-1EA23-4.4 | IE 1 | 2925 | 72 | 13.3 | 40.5 | 0.87 | 89.9 | 90.6 | 90.0 | 7.6 | 2.7 | 3.5 | 0.072 | K | 151 |
| 30 | 200L | 1LE0102-2AA43-4.4 | IE 1 | 2950 | 97 | 18.7 | 55 | 0.87 | 90.7 | 90.8 | 89.0 | 7.5 | 2.5 | 3.2 | 0.12 | K | 224 |
| 37 | 200L | 1LE0102-2AA53-4.4 | IE 1 | 2950 | 120 | 19.5 | 67 | 0.88 | 91.2 | 91.6 | 90.4 | 7.4 | 2.6 | 3.2 | 0.15 | K | 242 |
| 45 | 225M | 1LE0102-2BA23-4.4 | IE 1 | 2960 | 145 | 24.0 | 81 | 0.88 | 91.7 | 91.9 | 90.5 | 7.6 | 2.8 | 3.3 | 0.23 | K | 304 |
| 55 | 250M | 1LE0102-2CA23-4.4 | IE 1 | 2970 | 177 | 32.0 | 98 | 0.88 | 92.1 | 92.4 | 90.7 | 7.7 | 2.5 | 3.1 | 0.4 | K | 374 |
| 75 | 280S | 1LE0102-2DA03-4.4 | IE 1 | 2970 | 241 | 42.5 | 134 | 0.87 | 92.7 | 92.6 | 91.1 | 6.7 | 2.7 | 3 | 0.7 | J | 540 |
| 90 | 280M | 1LE0102-2DA23-4.4 | IE 1 | 2975 | 289 | 47.5 | 159 | 0.88 | 93.0 | 93.2 | 91.3 | 7.2 | 2.8 | 3 | 0.82 | J | 560 |
| 110 | 315S | 1LE0102-3AA03-4.4 | IE 1 | 2982 | 353 | 49.5 | 189 | 0.90 | 93.3 | 93.1 | 91.2 | 7.5 | 2.2 | 3.1 | 1.4 | K | 735 |
| 132 | 315M | 1LE0102-3AA23-4.4 | IE 1 | 2980 | 423 | 46.0 | 220 | 0.92 | 93.5 | 93.1 | 91.7 | 7.5 | 2.3 | 2.9 | 1.7 | J | 850 |
| 160 | 315L | 1LE0102-3AA53-4.4 | IE 1 | 2982 | 513 | 56 | 265 | 0.92 | 93.8 | 93.6 | 92.5 | 7.6 | 2.5 | 2.8 | 1.9 | J | 960 |
| 185 | 315L | 1LE0102-3AA63-4.4 | IE 1 | 2978 | 594 | 50 | 310 | 0.92 | 93.9 | 93.9 | 93.1 | 7.5 | 2.4 | 2.8 | 2.3 | J | 1070 |
| 200 | 315L | 1LE0102-3AA73-4.4 | IE 1 | 2980 | 641 | 65 | 335 | 0.92 | 94.0 | 94.3 | 93.2 | 7.9 | 2.5 | 2.6 | 2.3 | K | 1080 |
| 220 | 355M | 1LE0102-3BA23-4.4 | IE 1 | 2985 | 704 | 43.0 | 370 | 0.90 | 94.8 | 95.0 | 92.8 | 6.5 | 2 | 2.1 | 2.9 | H | 1590 |
| 250 | 355M | 1LE0102-3BA33-4.4 | IE 1 | 2985 | 800 | 54 | 420 | 0.90 | 95.2 | 95.2 | 93.0 | 6.5 | 2 | 2.1 | 3 | H | 1620 |
| 280 | 355L | 1LE0102-3BA53-4.4 | IE 1 | 2985 | 896 | 57 | 470 | 0.90 | 95.2 | 95.2 | 92.9 | 6.5 | 2 | 2.1 | 3.5 | H | 1820 |
| 315 | 355L | 1LE0102-3BA63-4.4 | IE 1 | 2985 | 1008 | 61 | 530 | 0.90 | 95.4 | 95.4 | 93.2 | 6.5 | 2 | 2.1 | 3.5 | H | 1830 |

SIMOTICS General Purpose (Cast Iron) – IE1

| Cast Iron Series | | | | | | |
|-----------------------|--------------------------|---|---|--------------------------|---|---|
| Efficiency class | IE1 | | | IE2 | | |
| Series | 1LE0102 | | | 1LE0101 | | |
| No. of poles | 2 | 4 | 6 | 2 | 4 | 6 |
| Cooling | Self-ventilated (IC 411) | | | Self-ventilated (IC 411) | | |
| Degree of protection | IP55 | | | IP55 | | |
| Insulation | Thermal class 155(F) | | | Thermal class 155(F) | | |
| Utilization | Thermal class 130(B) | | | Thermal class 130(B) | | |
| Frame size | 80 ... 355 | | | 80 ... 355 | | |
| Rated output at 50 Hz | 0.55 ... 315 kW | | | 0.55 ... 315 kW | | |
| Rated torque at 50 Hz | 2.6 ... 2412 Nm | | | 2.6 ... 2412 Nm | | |

| Electrical data - 1LE0 - IE1 - 4-pole (IE1 Cast Iron) 1500 rpm 4-pole, 400 V 50 Hz | | | | | | | | | | | | | | | | | |
|--|------------|--------------------|----------|-------------|--------------|-----------------|---------------|--------------------|---------------|------------|------------|------------------|-----------------|-------------------|-------------------|--------------|-------------------|
| Rated output | Frame size | Order number | IE class | Rated speed | Rated torque | No load current | Rated current | Rated power factor | Efficiency at | | | Starting current | Starting torque | Break-down torque | Moment of inertia | Torque class | Net weight (IMB3) |
| kW | | | | rpm | Nm | A | A | | 100% load % | 75% load % | 50% load % | A | Nm | Nm | kgm ² | | kg |
| 230 V Δ / 400 VY | | | | | | | | | | | | | | | | | |
| 0.55 | 80M | 1LE0102-0DB22-2..4 | - | 1415 | 3.7 | 0.76 | 1.43 | 0.81 | 69.4 | 69.9 | 66.8 | 4.5 | 2 | 2.6 | 0.0016 | D | 17.0 |
| 0.75 | 80M | 1LE0102-0DB32-2..4 | IE 1 | 1405 | 5.1 | 0.99 | 1.87 | 0.81 | 72.1 | 73.7 | 71.8 | 4.8 | 2 | 2.6 | 0.0019 | D | 18.5 |
| 1.1 | 90S | 1LE0102-0EB02-2..4 | IE 1 | 1420 | 7.4 | 1.58 | 2.65 | 0.80 | 75.0 | 77.3 | 74.3 | 5.4 | 2 | 2.6 | 0.0027 | E | 23 |
| 1.5 | 90L | 1LE0102-0EB42-2..4 | IE 1 | 1425 | 10 | 2.1 | 3.50 | 0.81 | 77.2 | 77.3 | 75.1 | 5.6 | 2 | 2.5 | 0.0034 | E | 26 |
| 2.2 | 100L | 1LE0102-1AB42-2..4 | IE 1 | 1425 | 14.8 | 2.80 | 4.95 | 0.81 | 79.7 | 80.7 | 78.7 | 5.8 | 2.4 | 2.9 | 0.0063 | E | 30 |
| 3 | 100L | 1LE0102-1AB52-2..4 | IE 1 | 1420 | 20.2 | 3.15 | 6.4 | 0.83 | 81.5 | 83.1 | 81.5 | 6.5 | 2.8 | 3.1 | 0.0081 | E | 33 |
| 4 | 112M | 1LE0102-1BB22-2..4 | IE 1 | 1445 | 26.4 | 9.2 | 8.8 | 0.79 | 83.1 | 83.3 | 81.5 | 7.4 | 2.8 | 3.3 | 0.011 | M | 44 |
| 5.5 | 132S | 1LE0102-1CB02-2..4 | IE 1 | 1450 | 36.2 | 9.7 | 11.4 | 0.82 | 84.7 | 85.5 | 84.3 | 6.5 | 2 | 3.1 | 0.019 | K | 59 |
| 7.5 | 132M | 1LE0102-1CB22-2..4 | IE 1 | 1435 | 50 | 12.0 | 15.4 | 0.82 | 86.0 | 87.2 | 87.2 | 6.4 | 2.3 | 3.1 | 0.025 | K | 70 |
| 400 V Δ / 690 VY | | | | | | | | | | | | | | | | | |
| 2.2 | 100L | 1LE0102-1AB43-4..4 | IE 1 | 1425 | 14.8 | 2.70 | 4.90 | 0.81 | 79.7 | 80.7 | 78.7 | 5.8 | 2.4 | 2.9 | 0.0063 | E | 30 |
| 3 | 100L | 1LE0102-1AB53-4..4 | IE 1 | 1420 | 20.2 | 3.15 | 6.4 | 0.83 | 81.5 | 83.1 | 81.5 | 6.5 | 2.8 | 3.1 | 0.0081 | E | 33 |
| 4 | 112M | 1LE0102-1BB23-4..4 | IE 1 | 1445 | 26.4 | 5.1 | 8.8 | 0.79 | 83.1 | 83.3 | 81.5 | 7.4 | 2.8 | 3.3 | 0.011 | M | 44 |
| 5.5 | 132S | 1LE0102-1CB03-4..4 | IE 1 | 1450 | 36.2 | 5.5 | 11.4 | 0.82 | 84.7 | 85.5 | 84.3 | 6.5 | 2 | 3.1 | 0.019 | K | 59 |
| 7.5 | 132M | 1LE0102-1CB23-4..4 | IE 1 | 1435 | 50 | 6.5 | 15.4 | 0.82 | 86.0 | 87.2 | 87.2 | 6.4 | 2.3 | 3.1 | 0.025 | K | 70 |
| 11 | 160M | 1LE0102-1DB23-4..4 | IE 1 | 1455 | 72 | 9.3 | 21.5 | 0.84 | 87.6 | 88.5 | 87.8 | 6.9 | 2.2 | 3.3 | 0.045 | K | 99 |
| 15 | 160L | 1LE0102-1DB43-4..4 | IE 1 | 1460 | 98 | 13.3 | 29.0 | 0.84 | 88.7 | 89.4 | 88.6 | 7.8 | 2.7 | 3.8 | 0.06 | L | 125 |
| 18.5 | 180M | 1LE0102-1EB23-4..4 | IE 1 | 1470 | 120 | 13.8 | 35.0 | 0.85 | 89.3 | 90.3 | 89.9 | 7.8 | 2.7 | 3.5 | 0.13 | L | 163 |
| 22 | 180L | 1LE0102-1EB43-4..4 | IE 1 | 1465 | 143 | 15.9 | 41.5 | 0.85 | 89.9 | 90.9 | 89.9 | 7.8 | 2.4 | 3.2 | 0.14 | L | 179 |
| 30 | 200L | 1LE0102-2AB43-4..4 | IE 1 | 1470 | 195 | 23.0 | 56 | 0.85 | 90.7 | 91.6 | 90.5 | 7.4 | 2.4 | 3.1 | 0.22 | K | 235 |
| 37 | 225S | 1LE0102-2BB03-4..4 | IE 1 | 1470 | 240 | 23.5 | 68 | 0.86 | 91.2 | 91.8 | 91.0 | 7.3 | 2.3 | 2.8 | 0.44 | K | 295 |
| 45 | 225M | 1LE0102-2BB23-4..4 | IE 1 | 1475 | 292 | 28.5 | 82 | 0.87 | 91.7 | 92.4 | 92.0 | 7.8 | 2.9 | 3.3 | 0.5 | K | 322 |
| 55 | 250M | 1LE0102-2CB23-4..4 | IE 1 | 1478 | 356 | 32.5 | 101 | 0.86 | 92.1 | 92.8 | 92.0 | 7.6 | 3 | 2.8 | 0.8 | K | 410 |
| 75 | 280S | 1LE0102-2DB03-4..4 | IE 1 | 1480 | 484 | 42.0 | 133 | 0.88 | 92.7 | 93.3 | 92.2 | 7.2 | 2.6 | 2.8 | 1.3 | J | 540 |
| 90 | 280M | 1LE0102-2DB23-4..4 | IE 1 | 1485 | 579 | 58 | 159 | 0.88 | 93.0 | 93.5 | 92.2 | 7.8 | 2.7 | 2.8 | 1.4 | K | 600 |
| 110 | 315S | 1LE0102-3AB03-4..4 | IE 1 | 1490 | 706 | 70 | 200 | 0.85 | 93.3 | 93.4 | 92.5 | 8.6 | 2.8 | 3.1 | 2.2 | L | 745 |
| 132 | 315M | 1LE0102-3AB23-4..4 | IE 1 | 1488 | 848 | 60 | 235 | 0.87 | 93.5 | 93.8 | 93.4 | 7.3 | 2.5 | 2.7 | 2.5 | J | 875 |
| 160 | 315L | 1LE0102-3AB53-4..4 | IE 1 | 1488 | 1030 | 83 | 285 | 0.87 | 93.8 | 94.0 | 93.6 | 7.4 | 3 | 2.9 | 3 | K | 950 |
| 185 | 315L | 1LE0102-3AB63-4..4 | IE 1 | 1490 | 1185 | 92 | 325 | 0.88 | 93.9 | 94.1 | 93.6 | 7.6 | 3 | 2.9 | 3.6 | K | 1060 |
| 200 | 315L | 1LE0102-3AB73-4..4 | IE 1 | 1488 | 1285 | 84 | 345 | 0.88 | 94.0 | 94.3 | 94.1 | 7.4 | 3 | 3 | 3.7 | J | 1070 |
| 220 | 355M | 1LE0102-3BB23-4..4 | IE 1 | 1490 | 1410 | 59 | 380 | 0.87 | 95.0 | 95.1 | 93.1 | 6.5 | 2.1 | 2.2 | 6.6 | H | 1630 |
| 250 | 355M | 1LE0102-3BB33-4..4 | IE 1 | 1490 | 1602 | 59 | 435 | 0.87 | 95.2 | 95.2 | 93.6 | 6.5 | 2.1 | 2.2 | 6.9 | H | 1650 |
| 280 | 355L | 1LE0102-3BB53-4..4 | IE 1 | 1490 | 1795 | 71 | 485 | 0.87 | 95.2 | 95.2 | 93.4 | 6.5 | 2.1 | 2.2 | 7.7 | H | 1820 |
| 315 | 355L | 1LE0102-3BB63-4..4 | IE 1 | 1490 | 2019 | 72 | 550 | 0.87 | 95.2 | 95.3 | 93.6 | 6.5 | 2.1 | 2.2 | 8.5 | H | 1890 |



The nominal torque of the motor is easy to calculate;
 Torque (Nm) =
 Power (kW) x 9550 / Speed (rpm).

SIMOTICS General Purpose (Cast Iron) – IE1

| | Cast Iron Series | | | | | |
|-----------------------|--------------------------|---|---|--------------------------|---|---|
| Efficiency class | IE1 | | | IE2 | | |
| Series | 1LE0102 | | | 1LE0101 | | |
| No. of poles | 2 | 4 | 6 | 2 | 4 | 6 |
| Cooling | Self-ventilated (IC 411) | | | Self-ventilated (IC 411) | | |
| Degree of protection | IP55 | | | IP55 | | |
| Insulation | Thermal class 155(F) | | | Thermal class 155(F) | | |
| Utilization | Thermal class 130(B) | | | Thermal class 130(B) | | |
| Frame size | 80 ... 355 | | | 80 ... 355 | | |
| Rated output at 50 Hz | 0.55 ... 315 kW | | | 0.55 ... 315 kW | | |
| Rated torque at 50 Hz | 2.6 ... 2412 Nm | | | 2.6 ... 2412 Nm | | |

Electrical data - 1LE0 - IE1 - 6-pole

(IE1 Cast Iron) 1000 rpm 6-pole, 400 V 50 Hz

| Rated output kW | Frame size | Order number | IE class | Rated speed rpm | Rated torque Nm | No load current A | Rated current A | Rated power factor | Efficiency at | | | Starting current A | Starting torque Nm | Break-down torque Nm | Moment of inertia kgm ² | Torque class | Net weight (IMB3) kg |
|-------------------------|------------|-------------------|----------|--------------------|--------------------|----------------------|--------------------|--------------------|---------------|------------|------------|-----------------------|-----------------------|-------------------------|---------------------------------------|--------------|-------------------------|
| | | | | | | | | | 100% load % | 75% load % | 50% load % | | | | | | |
| 230 V Δ / 400 VY | | | | | | | | | | | | | | | | | |
| 0.55 | 80M | 1LE0102-ODC32-2.4 | - | 910 | 5.8 | 1.04 | 1.60 | 0.74 | 67.5 | 68.7 | 65.6 | 3.8 | 2.1 | 2.4 | 0.0024 | C | 18.0 |
| 0.75 | 90S | 1LE0102-OEC02-2.4 | IE 1 | 925 | 7.7 | 1.27 | 2.10 | 0.74 | 70.0 | 71.5 | 68.9 | 3.9 | 2 | 2.5 | 0.0028 | C | 25 |
| 1.1 | 90L | 1LE0102-OEC42-2.4 | IE 1 | 935 | 11.3 | 1.89 | 3.00 | 0.73 | 72.9 | 74.0 | 71.8 | 4.4 | 2.2 | 2.7 | 0.0038 | D | 26 |
| 1.5 | 100L | 1LE0102-1AC42-2.4 | IE 1 | 940 | 15.4 | 2.30 | 3.80 | 0.76 | 75.2 | 77.2 | 74.7 | 4.6 | 2.1 | 2.6 | 0.0074 | D | 32 |
| 2.2 | 112M | 1LE0102-1BC22-2.4 | IE 1 | 940 | 22.3 | 3.00 | 5.5 | 0.75 | 77.7 | 79.2 | 78.1 | 5.2 | 2.4 | 3 | 0.01 | E | 42 |
| 3 | 132S | 1LE0102-1CC02-2.4 | IE 1 | 955 | 30 | 4.15 | 7.5 | 0.73 | 79.7 | 80.9 | 79.3 | 5.2 | 2 | 2.8 | 0.018 | E | 55 |
| 4 | 132M | 1LE0102-1CC22-2.4 | IE 1 | 955 | 40 | 10.8 | 9.7 | 0.73 | 81.4 | 82.2 | 79.4 | 5.6 | 2.1 | 2.9 | 0.023 | K | 65 |
| 5.5 | 132M | 1LE0102-1CC32-2.4 | IE 1 | 955 | 55 | 12.1 | 12.9 | 0.74 | 83.1 | 84.2 | 83.0 | 6 | 2.3 | 3.2 | 0.029 | K | 73 |
| 400 V Δ / 690 VY | | | | | | | | | | | | | | | | | |
| 1.5 | 100L | 1LE0102-1AC43-4.4 | IE 1 | 940 | 15.4 | 2.30 | 3.80 | 0.76 | 75.2 | 77.2 | 74.7 | 4.6 | 2.1 | 2.6 | 0.0074 | D | 32 |
| 2.2 | 112M | 1LE0102-1BC23-4.4 | IE 1 | 940 | 22.3 | 3.05 | 5.4 | 0.75 | 77.7 | 79.2 | 78.1 | 5.2 | 2.4 | 3 | 0.01 | E | 42 |
| 3 | 132S | 1LE0102-1CC03-4.4 | IE 1 | 955 | 30 | 4.15 | 7.4 | 0.73 | 79.7 | 80.9 | 79.3 | 5.2 | 2 | 2.8 | 0.018 | E | 55 |
| 4 | 132M | 1LE0102-1CC23-4.4 | IE 1 | 955 | 40 | 6.2 | 9.7 | 0.73 | 81.4 | 82.2 | 79.4 | 5.6 | 2.1 | 2.9 | 0.023 | K | 65 |
| 5.5 | 132M | 1LE0102-1CC33-4.4 | IE 1 | 955 | 55 | 7.3 | 12.9 | 0.74 | 83.1 | 84.2 | 83.0 | 6 | 2.3 | 3.2 | 0.029 | K | 73 |
| 7.5 | 160M | 1LE0102-1DC23-4.4 | IE 1 | 965 | 74 | 9.2 | 16.8 | 0.76 | 84.7 | 85.4 | 84.5 | 5.8 | 2 | 2.9 | 0.052 | K | 101 |
| 11 | 160L | 1LE0102-1DC43-4.4 | IE 1 | 965 | 109 | 13.3 | 24.0 | 0.76 | 86.4 | 87.0 | 86.0 | 6.6 | 2.2 | 3.1 | 0.072 | K | 128 |
| 15 | 180L | 1LE0102-1EC43-4.4 | IE 1 | 970 | 148 | 14.2 | 32.0 | 0.78 | 87.7 | 88.7 | 88.4 | 6.5 | 2.3 | 3 | 0.18 | K | 169 |
| 18.5 | 200L | 1LE0102-2AC43-4.4 | IE 1 | 975 | 182.1 | 13.1 | 36.5 | 0.82 | 88.6 | 90.0 | 90.1 | 5.8 | 2.2 | 2.8 | 0.26 | J | 218 |
| 22 | 200L | 1LE0102-2AC53-4.4 | IE 1 | 975 | 215 | 15.0 | 43.0 | 0.82 | 89.2 | 90.5 | 90.5 | 6.5 | 2.3 | 2.8 | 0.31 | J | 237 |
| 30 | 225M | 1LE0102-2BC23-4.4 | IE 1 | 978 | 293 | 23.0 | 58 | 0.83 | 90.2 | 91.4 | 90.5 | 6.7 | 2.4 | 2.8 | 0.6 | K | 290 |
| 37 | 250M | 1LE0102-2CC23-4.4 | IE 1 | 982 | 360 | 26.0 | 71 | 0.83 | 90.8 | 91.5 | 91.2 | 7.5 | 3 | 2.8 | 0.89 | K | 389 |
| 45 | 280S | 1LE0102-2DC03-4.4 | IE 1 | 985 | 437 | 28.0 | 84 | 0.85 | 91.4 | 92.4 | 92.3 | 7.1 | 2.5 | 2.8 | 1.1 | K | 500 |
| 55 | 280M | 1LE0102-2DC23-4.4 | IE 1 | 988 | 532 | 35.0 | 102 | 0.85 | 91.9 | 92.6 | 92.4 | 7.5 | 2.4 | 2.7 | 1.4 | K | 525 |
| 75 | 315S | 1LE0102-3AC03-4.4 | IE 1 | 988 | 725 | 55 | 141 | 0.83 | 92.6 | 93.0 | 92.4 | 7.5 | 2.4 | 3 | 2.3 | K | 675 |
| 90 | 315M | 1LE0102-3AC23-4.4 | IE 1 | 986 | 872 | 54 | 166 | 0.84 | 92.9 | 93.4 | 93.2 | 7 | 2.3 | 2.8 | 2.8 | K | 830 |
| 110 | 315L | 1LE0102-3AC53-4.4 | IE 1 | 986 | 1066 | 57 | 200 | 0.86 | 93.3 | 93.9 | 93.8 | 6.5 | 2.2 | 2.7 | 3.4 | J | 915 |
| 132 | 315L | 1LE0102-3AC63-4.4 | IE 1 | 988 | 1278 | 78 | 235 | 0.86 | 93.5 | 94.2 | 93.6 | 7.8 | 2.2 | 2.4 | 3.9 | K | 1010 |
| 160 | 355M | 1LE0102-3BC23-4.4 | IE 1 | 989 | 1545 | 53 | 275 | 0.88 | 94.5 | 94.6 | 92.4 | 6.5 | 2 | 2.1 | 7.7 | H | 1640 |
| 185 | 355M | 1LE0102-3BC33-4.4 | IE 1 | 989 | 1786 | 55 | 320 | 0.88 | 94.5 | 94.6 | 92.6 | 6.5 | 2 | 2.1 | 8.4 | H | 1680 |
| 200 | 355M | 1LE0102-3BC43-4.4 | IE 1 | 989 | 1931 | 60 | 345 | 0.88 | 94.7 | 94.7 | 93.4 | 6.5 | 2 | 2.1 | 9.1 | H | 1720 |
| 220 | 355L | 1LE0102-3BC53-4.4 | IE 1 | 989 | 2124 | 68 | 380 | 0.88 | 94.7 | 94.7 | 92.6 | 6.5 | 2 | 2.1 | 10.1 | H | 1840 |
| 250 | 355L | 1LE0102-3BC63-4.4 | IE 1 | 989 | 2414 | 80 | 430 | 0.88 | 94.7 | 94.7 | 93.4 | 6.5 | 2 | 2.1 | 11.4 | H | 1920 |

SIMOTICS General Purpose (Cast Iron) – IE2

| Cast Iron Series | | | | | | |
|-----------------------|--------------------------|---|---|--------------------------|---|---|
| Efficiency class | IE1 | | | IE2 | | |
| Series | 1LE0102 | | | 1LE0101 | | |
| No. of poles | 2 | 4 | 6 | 2 | 4 | 6 |
| Cooling | Self-ventilated (IC 411) | | | Self-ventilated (IC 411) | | |
| Degree of protection | IP55 | | | IP55 | | |
| Insulation | Thermal class 155(F) | | | Thermal class 155(F) | | |
| Utilization | Thermal class 130(B) | | | Thermal class 130(B) | | |
| Frame size | 80 ... 355 | | | 80 ... 355 | | |
| Rated output at 50 Hz | 0.55 ... 315 kW | | | 0.55 ... 315 kW | | |
| Rated torque at 50 Hz | 2.6 ... 2412 Nm | | | 2.6 ... 2412 Nm | | |

| Electrical data - 1LE0 - IE2 - 2-pole | | | | | | | | | | | | | | | (IE2 Cast Iron) 3000 rpm 2-pole, 400 V 50 Hz | | |
|---------------------------------------|------------|--------------------|----------|-------------|--------------|-----------------|---------------|--------------------|---------------|------------|------------|------------------|-----------------|-------------------|--|--------------|-------------------|
| Rated output | Frame size | Order number | IE class | Rated speed | Rated torque | No load current | Rated current | Rated power factor | Efficiency at | | | Starting current | Starting torque | Break-down torque | Moment of inertia | Torque class | Net weight (IMB3) |
| kW | | | | rpm | Nm | A | A | | 100% load % | 75% load % | 50% load % | A | Nm | Nm | kgm ² | | kg |
| 230 VΔ / 400 VY | | | | | | | | | | | | | | | | | |
| 0.75 | 80M | 1LE0101-ODA22-2.4 | IE 2 | 2795 | 2.6 | 0.70 | 1.67 | 0.84 | 77.4 | 78.5 | 78.5 | 5.6 | 2.4 | 2.4 | 0.00080 | D | 15.5 |
| 1.1 | 80M | 1LE0101-ODA32-2.4 | IE 2 | 2835 | 3.7 | 1.13 | 2.40 | 0.84 | 79.6 | 80.6 | 77.4 | 6.0 | 2.8 | 3.2 | 0.0012 | E | 17.5 |
| 1.5 | 90S | 1LE0101-OEA02-2.4 | IE 2 | 2890 | 5.0 | 1.52 | 3.20 | 0.84 | 81.3 | 81.7 | 78.0 | 6.5 | 2.4 | 3.1 | 0.0021 | E | 23 |
| 2.2 | 90L | 1LE0101-OEA42-2.4 | IE 2 | 2890 | 7.3 | 2.30 | 4.55 | 0.85 | 83.2 | 83.7 | 80.8 | 7.2 | 2.6 | 3.5 | 0.0026 | F | 26 |
| 3 | 100L | 1LE0101-1AA42-2.4 | IE 2 | 2885 | 9.9 | 2.85 | 6.1 | 0.84 | 84.6 | 85.1 | 84.1 | 7.5 | 4.0 | 4.5 | 0.0036 | F | 34 |
| 4 | 112M | 1LE0101-1BA22-2.4 | IE 2 | 2930 | 13.0 | 5.9 | 7.8 | 0.86 | 85.8 | 86.6 | 84.7 | 7.5 | 2.2 | 2.9 | 0.0064 | L | 40 |
| 5.5 | 132S | 1LE0101-1CA02-2.B4 | IE 2 | 2930 | 17.9 | 6.9 | 10.5 | 0.87 | 87.0 | 87.6 | 86.9 | 7.5 | 2.2 | 2.9 | 0.014 | K | 56 |
| 7.5 | 132S | 1LE0101-1CA12-2.B4 | IE 2 | 2930 | 24.4 | 8.4 | 13.8 | 0.89 | 88.1 | 88.8 | 88.5 | 7.5 | 2.3 | 2.9 | 0.017 | K | 62 |
| 400 VΔ / 690 VY | | | | | | | | | | | | | | | | | |
| 3 | 100L | 1LE0101-1AA43-4.4 | IE 2 | 2885 | 9.9 | 2.85 | 6.1 | 0.84 | 84.6 | 85.1 | 84.1 | 7.5 | 4 | 4.5 | 0.0036 | F | 34 |
| 4 | 112M | 1LE0101-1BA23-4.4 | IE 2 | 2930 | 13.0 | 3.70 | 7.8 | 0.86 | 85.8 | 86.6 | 84.7 | 7.5 | 2.2 | 2.9 | 0.0064 | L | 40 |
| 5.5 | 132S | 1LE0101-1CA03-4.B4 | IE 2 | 2930 | 17.9 | 4.30 | 10.5 | 0.87 | 87.0 | 87.6 | 86.9 | 7.5 | 2.2 | 2.9 | 0.014 | K | 56 |
| 7.5 | 132S | 1LE0101-1CA13-4.B4 | IE 2 | 2930 | 24.4 | 4.65 | 13.8 | 0.89 | 88.1 | 88.8 | 88.5 | 7.5 | 2.3 | 2.9 | 0.017 | K | 62 |
| 11 | 160M | 1LE0101-1DA23-4.B4 | IE 2 | 2935 | 35.8 | 8.1 | 20.5 | 0.86 | 89.4 | 90.1 | 89.3 | 7.5 | 2.2 | 2.9 | 0.031 | K | 96 |
| 15 | 160M | 1LE0101-1DA33-4.B4 | IE 2 | 2935 | 48.8 | 10.4 | 28 | 0.86 | 90.3 | 91.0 | 90.5 | 7.5 | 2.4 | 3.2 | 0.038 | K | 106 |
| 18.5 | 160L | 1LE0101-1DA43-4.B4 | IE 2 | 2935 | 60.2 | 10.3 | 33 | 0.89 | 90.9 | 91.7 | 91.5 | 7.5 | 2.4 | 3.2 | 0.046 | K | 125 |
| 22 | 180M | 1LE0101-1EA23-4.B4 | IE 2 | 2935 | 71.6 | 13.5 | 40 | 0.87 | 91.3 | 91.8 | 91.1 | 7.6 | 2.5 | 3.2 | 0.072 | K | 152 |
| 30 | 200L | 1LE0101-2AA43-4.B4 | IE 2 | 2955 | 97.0 | 18.0 | 55 | 0.86 | 92.0 | 92.3 | 91.5 | 7.5 | 2.5 | 3.2 | 0.13 | K | 229 |
| 37 | 200L | 1LE0101-2AA53-4.B4 | IE 2 | 2955 | 120 | 19.0 | 66 | 0.88 | 92.5 | 92.8 | 92.3 | 7.5 | 2.5 | 3.2 | 0.15 | K | 245 |
| 45 | 225M | 1LE0101-2BA23-4.B4 | IE 2 | 2965 | 145 | 23.0 | 80 | 0.88 | 92.9 | 93.1 | 92.5 | 7.9 | 2.5 | 3.1 | 0.24 | K | 307 |
| 55 | 250M | 1LE0101-2CA23-4.B4 | IE 2 | 2970 | 177 | 28.5 | 97 | 0.88 | 93.2 | 93.2 | 91.8 | 7.5 | 2.5 | 3 | 0.42 | K | 378 |
| 75 | 280S | 1LE0101-2DA03-4.B4 | IE 2 | 2975 | 241 | 41.0 | 133 | 0.87 | 93.8 | 93.8 | 92.7 | 7.5 | 2.8 | 3 | 0.75 | K | 550 |
| 90 | 280M | 1LE0101-2DA23-4.B4 | IE 2 | 2978 | 289 | 49.5 | 159 | 0.87 | 94.1 | 94.1 | 92.9 | 7.5 | 3 | 3.1 | 0.88 | K | 570 |
| 110 | 315S | 1LE0101-3AA03-4.B4 | IE 2 | 2982 | 352 | 47.5 | 187 | 0.90 | 94.3 | 94.3 | 93.3 | 7.5 | 2.2 | 2.6 | 1.4 | J | 740 |
| 132 | 315M | 1LE0101-3AA23-4.B4 | IE 2 | 2982 | 423 | 46.5 | 220 | 0.91 | 94.6 | 94.6 | 93.9 | 7.5 | 2.3 | 2.9 | 1.7 | J | 855 |
| 160 | 315L | 1LE0101-3AA53-4.B4 | IE 2 | 2982 | 512 | 52 | 265 | 0.92 | 94.8 | 95.1 | 94.1 | 7.5 | 2.5 | 2.8 | 1.9 | J | 970 |
| 185 | 315L | 1LE0101-3AA63-4.B4 | IE 2 | 2982 | 592 | 64 | 305 | 0.92 | 95.0 | 95.3 | 94.2 | 7.5 | 2.5 | 2.8 | 2.3 | J | 1080 |
| 200 | 315L | 1LE0101-3AA73-4.B4 | IE 2 | 2982 | 641 | 64 | 330 | 0.92 | 95.0 | 95.3 | 94.4 | 7.5 | 2.5 | 2.8 | 2.3 | J | 1090 |
| 220 | 355M | 1LE0101-3BA23-4.B4 | IE 2 | 2980 | 705 | 50 | 370 | 0.90 | 95.0 | 95.0 | 92.8 | 7.1 | 2 | 2.2 | 2.9 | J | 1600 |
| 250 | 355M | 1LE0101-3BA33-4.B4 | IE 2 | 2980 | 801 | 46 | 420 | 0.90 | 95.0 | 95.0 | 93.0 | 7.1 | 2 | 2.2 | 3 | J | 1650 |
| 280 | 355L | 1LE0101-3BA53-4.B4 | IE 2 | 2980 | 897 | 56 | 475 | 0.90 | 95.0 | 95.1 | 93.0 | 7.1 | 2 | 2.2 | 3.5 | J | 1830 |
| 315 | 355L | 1LE0101-3BA63-4.B4 | IE 2 | 2980 | 1009 | 57 | 530 | 0.90 | 95.0 | 95.1 | 93.1 | 7.1 | 2 | 2.3 | 3.5 | J | 1840 |



The nominal torque of the motor is easy to calculate;
 Torque (Nm) =
 Power (kW) x 9550 / Speed (rpm).

SIMOTICS General Purpose (Cast Iron) – IE2

| | Cast Iron Series | | | | | |
|-----------------------|--------------------------|---|---|--------------------------|---|---|
| Efficiency class | IE1 | | | IE2 | | |
| Series | 1LE0102 | | | 1LE0101 | | |
| No. of poles | 2 | 4 | 6 | 2 | 4 | 6 |
| Cooling | Self-ventilated (IC 411) | | | Self-ventilated (IC 411) | | |
| Degree of protection | IP55 | | | IP55 | | |
| Insulation | Thermal class 155(F) | | | Thermal class 155(F) | | |
| Utilization | Thermal class 130(B) | | | Thermal class 130(B) | | |
| Frame size | 80 ... 355 | | | 80 ... 355 | | |
| Rated output at 50 Hz | 0.55 ... 315 kW | | | 0.55 ... 315 kW | | |
| Rated torque at 50 Hz | 2.6 ... 2412 Nm | | | 2.6 ... 2412 Nm | | |

| Electrical data - 1LE0 - IE2 - 4-pole (IE2 Cast Iron) 1500 rpm 4-pole, 400 V 50 Hz | | | | | | | | | | | | | | | | | |
|--|------------|--------------------|----------|-------------|--------------|-----------------|---------------|--------------------|---------------|------------|------------|------------------|-----------------|-------------------|-------------------|--------------|-------------------|
| Rated output | Frame size | Order number | IE class | Rated speed | Rated torque | No load current | Rated current | Rated power factor | Efficiency at | | | Starting current | Starting torque | Break-down torque | Moment of inertia | Torque class | Net weight (IMB3) |
| kW | | | | rpm | Nm | A | A | | 100% load % | 75% load % | 50% load % | A | Nm | Nm | kgm ² | | kg |
| 230 V Δ / 400 VY | | | | | | | | | | | | | | | | | |
| 0.55 | 80M | 1LE0101-0DB22-2..4 | - | 1425 | 3.7 | 0.80 | 1.34 | 0.80 | 74.0 | 74.7 | 70.1 | 6.0 | 2.0 | 2.7 | 0.0021 | F | 17.5 |
| 0.75 | 80M | 1LE0101-0DB32-2..4 | IE 2 | 1440 | 5.0 | 1.00 | 1.82 | 0.75 | 79.6 | 79.6 | 76.8 | 6.5 | 2.8 | 3.5 | 0.0027 | F | 19 |
| 1.1 | 90S | 1LE0101-0EB02-2..4 | IE 2 | 1440 | 7.3 | 1.60 | 2.65 | 0.75 | 81.4 | 81.4 | 77.6 | 7.0 | 2.8 | 3.5 | 0.0041 | G | 24 |
| 1.5 | 90L | 1LE0101-0EB42-2..4 | IE 2 | 1440 | 9.9 | 2.05 | 3.45 | 0.76 | 82.8 | 82.8 | 80.2 | 7.0 | 3.0 | 3.8 | 0.0047 | G | 27 |
| 2.2 | 100L | 1LE0101-1AB42-2..4 | IE 2 | 1435 | 14.6 | 2.65 | 4.8 | 0.79 | 84.3 | 85.0 | 83.1 | 7.0 | 3.0 | 3.2 | 0.0081 | F | 33 |
| 3 | 100L | 1LE0101-1AB52-2..4 | IE 2 | 1435 | 20.0 | 3.50 | 6.4 | 0.79 | 85.5 | 86.3 | 84.2 | 7.0 | 3.0 | 3.2 | 0.01 | F | 37 |
| 4 | 112M | 1LE0101-1BB22-2..4 | IE 2 | 1445 | 26.4 | 7.6 | 8.4 | 0.79 | 86.6 | 87.1 | 85.8 | 7.1 | 2.7 | 3.1 | 0.011 | L | 45 |
| 5.5 | 132S | 1LE0101-1CB02-2.B4 | IE 2 | 1460 | 36.0 | 10.6 | 11.5 | 0.79 | 87.7 | 88.2 | 86.9 | 7.5 | 2.5 | 3.1 | 0.021 | L | 61 |
| 7.5 | 132M | 1LE0101-1CB22-2.B4 | IE 2 | 1460 | 49.1 | 11.5 | 14.9 | 0.82 | 88.7 | 89.4 | 88.8 | 7.7 | 2.7 | 3.2 | 0.029 | L | 73 |
| 400 V Δ / 690 VY | | | | | | | | | | | | | | | | | |
| 2.2 | 100L | 1LE0101-1AB43-4..4 | IE 2 | 1435 | 14.6 | 2.6 | 4.75 | 0.79 | 84.3 | 85.0 | 83.1 | 7.0 | 3.0 | 3.2 | 0.0081 | F | 33 |
| 3 | 100L | 1LE0101-1AB53-4..4 | IE 2 | 1435 | 20.0 | 3.55 | 6.4 | 0.79 | 85.5 | 86.3 | 84.2 | 7.0 | 3.0 | 3.2 | 0.010 | F | 37 |
| 4 | 112M | 1LE0101-1BB23-4..4 | IE 2 | 1445 | 26.4 | 4.45 | 8.455 | 0.79 | 86.6 | 87.1 | 85.8 | 7.1 | 2.7 | 3.1 | 0.011 | L | 45 |
| 5.5 | 132S | 1LE0101-1CB03-4.B4 | IE 2 | 1460 | 36.0 | 6.1 | 11.495 | 0.79 | 87.7 | 88.2 | 86.9 | 7.5 | 2.5 | 3.1 | 0.021 | L | 61 |
| 7.5 | 132M | 1LE0101-1CB23-4.B4 | IE 2 | 1460 | 49.1 | 6.7 | 14.915 | 0.82 | 88.7 | 89.4 | 88.8 | 7.7 | 2.7 | 3.2 | 0.029 | L | 73 |
| 11 | 160M | 1LE0101-1DB23-4.B4 | IE 2 | 1465 | 71.7 | 6.7 | 21 | 0.84 | 89.8 | 90.4 | 90.1 | 7.5 | 2.5 | 3.1 | 0.051 | K | 103 |
| 15 | 160L | 1LE0101-1DB43-4.B4 | IE 2 | 1465 | 97.8 | 11.8 | 28.025 | 0.85 | 90.6 | 91.3 | 90.6 | 7.8 | 2.7 | 3.2 | 0.066 | K | 130 |
| 18.5 | 180M | 1LE0101-1EB23-4.B4 | IE 2 | 1465 | 121 | 12.3 | 34.5 | 0.85 | 91.2 | 91.8 | 91.8 | 7.3 | 2.5 | 3.2 | 0.13 | K | 165 |
| 22 | 180L | 1LE0101-1EB43-4.B4 | IE 2 | 1465 | 143 | 15.4 | 41 | 0.85 | 91.6 | 92.3 | 92.7 | 7.3 | 2.4 | 3.2 | 0.14 | K | 180 |
| 30 | 200L | 1LE0101-2AB43-4.B4 | IE 2 | 1470 | 195 | 19.0 | 55 | 0.85 | 92.3 | 92.9 | 92.9 | 7.3 | 2.7 | 3.2 | 0.22 | K | 238 |
| 37 | 225S | 1LE0101-2BB03-4.B4 | IE 2 | 1475 | 240 | 23.0 | 67 | 0.86 | 92.7 | 93.2 | 92.9 | 7.3 | 2.7 | 3.2 | 0.45 | K | 298 |
| 45 | 225M | 1LE0101-2BB23-4.B4 | IE 2 | 1475 | 291 | 26.0 | 80 | 0.87 | 93.1 | 93.5 | 93.9 | 7.3 | 2.7 | 3.2 | 0.51 | K | 322 |
| 55 | 250M | 1LE0101-2CB23-4.B4 | IE 2 | 1480 | 355 | 32.0 | 99 | 0.86 | 93.5 | 93.9 | 93.3 | 7.5 | 3.1 | 3.5 | 0.8 | K | 410 |
| 75 | 280S | 1LE0101-2DB03-4.B4 | IE 2 | 1485 | 482 | 45.0 | 132 | 0.87 | 94.0 | 94.3 | 93.9 | 7.5 | 2.7 | 3.1 | 1.4 | K | 555 |
| 90 | 280M | 1LE0101-2DB23-4.B4 | IE 2 | 1485 | 579 | 57 | 159 | 0.87 | 94.2 | 94.3 | 94.2 | 7.5 | 2.7 | 3.1 | 1.5 | K | 610 |
| 110 | 315S | 1LE0101-3AB03-4.B4 | IE 2 | 1488 | 706 | 67 | 195 | 0.86 | 94.5 | 94.5 | 93.9 | 7.3 | 2.8 | 2.9 | 2.2 | K | 750 |
| 132 | 315M | 1LE0101-3AB23-4.B4 | IE 2 | 1486 | 848 | 56 | 230 | 0.88 | 94.7 | 94.7 | 95.0 | 7.3 | 2.5 | 2.7 | 2.5 | J | 875 |
| 160 | 315L | 1LE0101-3AB53-4.B4 | IE 2 | 1488 | 1027 | 77 | 275 | 0.88 | 94.9 | 94.9 | 95.1 | 7.4 | 3.0 | 2.9 | 3.0 | J | 960 |
| 185 | 315L | 1LE0101-3AB63-4.B4 | IE 2 | 1488 | 1187 | 86 | 320 | 0.88 | 95.1 | 95.1 | 95.0 | 7.4 | 3.0 | 3.0 | 3.6 | J | 1070 |
| 200 | 315L | 1LE0101-3AB73-4.B4 | IE 2 | 1488 | 1284 | 86 | 345 | 0.88 | 95.1 | 95.1 | 95.1 | 7.4 | 3.0 | 3.0 | 3.7 | J | 1080 |
| 220 | 355M | 1LE0101-3BB23-4.B4 | IE 2 | 1490 | 1410 | 69 | 370 | 0.90 | 95.1 | 95.2 | 93.3 | 6.9 | 2.0 | 2.2 | 6.6 | J | 1640 |
| 250 | 355M | 1LE0101-3BB33-4.B4 | IE 2 | 1490 | 1602 | 61 | 420 | 0.90 | 95.1 | 95.2 | 93.8 | 6.9 | 2.0 | 2.2 | 6.9 | J | 1680 |
| 280 | 355L | 1LE0101-3BB53-4.B4 | IE 2 | 1490 | 1795 | 66 | 470 | 0.90 | 95.1 | 95.2 | 93.8 | 6.9 | 2.0 | 2.2 | 7.7 | J | 1830 |
| 315 | 355L | 1LE0101-3BB63-4.B4 | IE 2 | 1490 | 2019 | 75 | 530 | 0.90 | 95.1 | 95.2 | 93.8 | 6.9 | 2.0 | 2.2 | 8.5 | J | 1900 |

SIMOTICS General Purpose (Cast Iron) – IE2

| Cast Iron Series | | | | | | |
|-----------------------|--------------------------|---|---|--------------------------|---|---|
| Efficiency class | IE1 | | | IE2 | | |
| Series | 1LE0102 | | | 1LE0101 | | |
| No. of poles | 2 | 4 | 6 | 2 | 4 | 6 |
| Cooling | Self-ventilated (IC 411) | | | Self-ventilated (IC 411) | | |
| Degree of protection | IP55 | | | IP55 | | |
| Insulation | Thermal class 155(F) | | | Thermal class 155(F) | | |
| Utilization | Thermal class 130(B) | | | Thermal class 130(B) | | |
| Frame size | 80 ... 355 | | | 80 ... 355 | | |
| Rated output at 50 Hz | 0.55 ... 315 kW | | | 0.55 ... 315 kW | | |
| Rated torque at 50 Hz | 2.6 ... 2412 Nm | | | 2.6 ... 2412 Nm | | |

| Electrical data - 1LE0 - IE2 - 6-pole (IE2 Cast Iron) 1000 rpm 6-pole, 400 V 50 Hz | | | | | | | | | | | | | | | | | |
|--|------------|---------------------|----------|-------------|--------------|-----------------|---------------|--------------------|---------------|------------|------------|------------------|-----------------|-------------------|-------------------|--------------|-------------------|
| Rated output | Frame size | Order number | IE class | Rated speed | Rated torque | No load current | Rated current | Rated power factor | Efficiency at | | | Starting current | Starting torque | Break-down torque | Moment of inertia | Torque class | Net weight (IMB3) |
| kW | | | | rpm | Nm | A | A | | 100% load % | 75% load % | 50% load % | A | Nm | Nm | kgm ² | | kg |
| 230 V Δ / 400 VY | | | | | | | | | | | | | | | | | |
| 0.55 | 80M | 1LE0101-ODC32-2..4 | - | 895 | 5.9 | 1.08 | 1.48 | 0.76 | 71.0 | 72.0 | 68.5 | 3.8 | 2.1 | 2.4 | 0.0028 | C | 18.5 |
| 0.75 | 90S | 1LE0101-OEC02-2..4 | IE 2 | 935 | 7.7 | 1.27 | 2.00 | 0.71 | 75.9 | 76.5 | 72.7 | 3.9 | 2.0 | 2.5 | 0.0038 | C | 26 |
| 1.1 | 90L | 1LE0101-OEC42-2..4 | IE 2 | 945 | 11.1 | 2.00 | 2.85 | 0.71 | 78.1 | 78.1 | 75.7 | 4.4 | 2.2 | 2.7 | 0.0046 | D | 27 |
| 1.5 | 100L | 1LE0101-1AC42-2..4 | IE 2 | 945 | 15.2 | 2.45 | 3.70 | 0.74 | 79.8 | 80.1 | 78.2 | 4.6 | 2.1 | 2.6 | 0.0086 | D | 34 |
| 2.2 | 112M | 1LE0101-1BC22-2..4 | IE 2 | 950 | 22.1 | 2.90 | 5.4 | 0.73 | 81.8 | 82.5 | 81.0 | 5.2 | 2.4 | 3.0 | 0.012 | E | 44 |
| 3 | 132S | 1LE0101-1CC02-2..4 | IE 2 | 960 | 29.8 | 3.70 | 7.2 | 0.73 | 83.3 | 84.3 | 83.4 | 5.2 | 2.0 | 2.8 | 0.019 | E | 56 |
| 4 | 132M | 1LE0101-1CC22-2..4 | IE 2 | 960 | 39.8 | 8.7 | 9.4 | 0.73 | 84.6 | 85.4 | 84.5 | 5.6 | 2.1 | 2.9 | 0.024 | K | 66 |
| 5.5 | 132M | 1LE0101-1CC32-2..B4 | IE 2 | 960 | 54.7 | 12.6 | 12.3 | 0.75 | 86.0 | 86.6 | 85.7 | 6.0 | 2.3 | 3.2 | 0.031 | K | 75 |
| 400 V Δ / 690 VY | | | | | | | | | | | | | | | | | |
| 1.5 | 100L | 1LE0101-1AC43-4..4 | IE 2 | 945 | 15.2 | 2.40 | 3.65 | 0.74 | 79.8 | 80.1 | 78.2 | 4.6 | 2.1 | 2.6 | 0.0086 | D | 34 |
| 2.2 | 112M | 1LE0101-1BC23-4..4 | IE 2 | 950 | 22.1 | 2.90 | 5.3 | 0.73 | 81.8 | 82.5 | 81.0 | 5.2 | 2.4 | 3.0 | 0.012 | E | 44 |
| 3 | 132S | 1LE0101-1CC03-4..4 | IE 2 | 960 | 29.8 | 3.70 | 7.1 | 0.73 | 83.3 | 84.3 | 83.4 | 5.2 | 2.0 | 2.8 | 0.019 | D | 56 |
| 4 | 132M | 1LE0101-1CC23-4..4 | IE 2 | 960 | 39.8 | 5.0 | 9.3 | 0.73 | 84.6 | 85.4 | 84.5 | 5.6 | 2.1 | 2.9 | 0.024 | K | 66 |
| 5.5 | 132M | 1LE0101-1CC33-4..B4 | IE 2 | 960 | 54.7 | 6.8 | 12.4 | 0.75 | 86.0 | 86.6 | 85.7 | 6.0 | 2.3 | 3.2 | 0.031 | K | 75 |
| 7.5 | 160M | 1LE0101-1DC23-4..B4 | IE 2 | 965 | 74.2 | 7.9 | 16.2 | 0.77 | 87.2 | 87.9 | 87.2 | 5.8 | 2.0 | 2.9 | 0.056 | J | 104 |
| 11 | 160L | 1LE0101-1DC43-4..B4 | IE 2 | 965 | 109 | 10.7 | 23.0 | 0.78 | 88.7 | 89.4 | 89.5 | 6.6 | 2.2 | 3.1 | 0.077 | K | 132 |
| 15 | 180L | 1LE0101-1EC43-4..B4 | IE 2 | 975 | 147 | 14.8 | 31.0 | 0.78 | 89.7 | 90.4 | 89.9 | 6.5 | 2.3 | 3.0 | 0.18 | K | 170 |
| 18.5 | 200L | 1LE0101-2AC43-4..B4 | IE 2 | 975 | 181 | 13.8 | 36.5 | 0.81 | 90.4 | 91.0 | 91.8 | 5.8 | 2.2 | 2.8 | 0.27 | J | 220 |
| 22 | 200L | 1LE0101-2AC53-4..B4 | IE 2 | 975 | 215 | 16.4 | 43.0 | 0.82 | 90.9 | 91.4 | 91.9 | 6.5 | 2.3 | 2.8 | 0.32 | J | 240 |
| 30 | 225M | 1LE0101-2BC23-4..B4 | IE 2 | 980 | 292 | 19.5 | 57 | 0.83 | 91.7 | 92.3 | 92.7 | 6.7 | 2.4 | 2.8 | 0.62 | J | 294 |
| 37 | 250M | 1LE0101-2CC23-4..B4 | IE 2 | 982 | 360 | 23.0 | 69 | 0.83 | 92.2 | 92.8 | 92.3 | 7.5 | 3.0 | 2.8 | 0.91 | K | 394 |
| 45 | 280S | 1LE0101-2DC03-4..B4 | IE 2 | 985 | 436 | 28.0 | 83 | 0.85 | 92.7 | 93.3 | 93.5 | 7.1 | 2.5 | 2.8 | 1.2 | K | 510 |
| 55 | 280M | 1LE0101-2DC23-4..B4 | IE 2 | 986 | 533 | 34.5 | 101 | 0.85 | 93.1 | 93.7 | 93.6 | 7.5 | 2.4 | 2.7 | 1.5 | K | 535 |
| 75 | 315S | 1LE0101-3AC03-4..B4 | IE 2 | 986 | 726 | 53 | 136 | 0.85 | 93.7 | 94.3 | 93.8 | 7.5 | 2.4 | 3.0 | 2.3 | K | 680 |
| 90 | 315M | 1LE0101-3AC23-4..B4 | IE 2 | 986 | 872 | 51 | 163 | 0.85 | 94.0 | 94.5 | 94.4 | 7.0 | 2.3 | 2.8 | 2.8 | J | 835 |
| 110 | 315L | 1LE0101-3AC53-4..B4 | IE 2 | 988 | 1063 | 57 | 195 | 0.86 | 94.3 | 94.7 | 94.6 | 6.5 | 2.2 | 2.7 | 3.9 | J | 975 |
| 132 | 315L | 1LE0101-3AC63-4..B4 | IE 2 | 988 | 1276 | 69 | 230 | 0.86 | 94.6 | 95.0 | 94.9 | 7.8 | 2.2 | 2.4 | 4.3 | K | 1030 |
| 160 | 355M | 1LE0101-3BC23-4..B4 | IE 2 | 990 | 1543 | 50 | 280 | 0.87 | 94.8 | 95.1 | 93.5 | 6.5 | 2.0 | 2.1 | 7.7 | J | 1650 |
| 185 | 355M | 1LE0101-3BC33-4..B4 | IE 2 | 990 | 1785 | 57 | 325 | 0.87 | 95.0 | 95.3 | 93.5 | 6.5 | 2.0 | 2.1 | 8.4 | J | 1690 |
| 200 | 355M | 1LE0101-3BC43-4..B4 | IE 2 | 990 | 1929 | 56 | 350 | 0.87 | 95.0 | 95.3 | 93.6 | 6.5 | 2.0 | 2.1 | 9.1 | J | 1730 |
| 220 | 355L | 1LE0101-3BC53-4..B4 | IE 2 | 990 | 2122 | 64 | 385 | 0.87 | 95.0 | 95.3 | 93.5 | 6.5 | 2.0 | 2.1 | 10.1 | J | 1850 |
| 250 | 355L | 1LE0101-3BC63-4..B4 | IE 2 | 990 | 2412 | 73 | 435 | 0.87 | 95.0 | 95.3 | 93.5 | 6.5 | 2.0 | 2.1 | 11.4 | J | 1930 |

Distribution Motor Options

| Aluminum | | Series | | | | | | | | |
|--|--|---------------------------------------|--|-------------------------------|--|-----------|----|------------------|------------------|------------------|
| SIMOTICS GP 1LA7 Standard Efficiency IE1 | | 1 | | available | | available | | | | |
| SIMOTICS GP 1LE10 Standard Efficiency IE1 | | 2 | | | | | | | | |
| SIMOTICS GP 1LE10 High Efficiency IE2 | | 3 | | | | available | | | | |
| Cast Iron | | | | | | | | | | |
| SIMOTICS GP 1LE0 Standard Efficiency IE1 | | 4 | | | | available | | | | |
| SIMOTICS GP 1LE0 High Efficiency IE2 | | 5 | | | | available | | | | |
| Option Description | | Motor Order Code | | Series Availability | | 63 | 71 | 80 | 90 | 100 |
| Voltage and frequency | | | | | | | | | | |
| 230 VΔ/400 VY, 50 Hz | | 1LE.....2-2... 1LA7.....1. | | 2,3,4,5 1 | | □ | □ | □ | □ | □ |
| 400 VΔ/690 VY, 50 Hz | | 1LE.....3-4... | | 2,3,4,5 | | - | - | - | - | □ |
| 220 VΔ/380 VY, 50 Hz | | 1LE.....2-1... 1LA7.....9. | | L1R 2,3,4,5 1 | | ✓ | ✓ | ✓ | ✓ | ✓ |
| 380 VΔ/660 VY, 50 Hz | | 1LE010.....3-3... | | 2,3,4,5 | | - | - | - | - | ✓ |
| 415 VY, 50 Hz | | 1LE010.....2-3... 1LA7.....9. | | L1C 2,3,4,5 1 | | ✓ | ✓ | ✓ | ✓ | ✓ |
| 415 VΔ, 50 Hz | | 1LE010.....3-5... | | 2,3,4,5 | | - | - | - | - | ✓ |
| 525 VΔ, 50 Hz | | 1LE010.....4-1... 1LA7.....9. | | L1Y 2,3,4,5 1 | | ✓ | ✓ | ✓ | ✓ | ✓ |
| Type of construction | | | | | | | | | | |
| IM B3 | | 1LE.....A... 1LA7.....0 | | 2,3,4,5 1 | | □ | □ | □ | □ | □ |
| IM B35 | | 1LE.....J... 1LA7.....6 | | 2,3,4,5 1 | | ✓ | ✓ | ✓ | ✓ | ✓ |
| IM B5 | | 1LE.....F... 1LA7.....1 | | 2,3,4,5 1 | | ✓ | ✓ | ✓ | ✓ | ✓ |
| IM V1 (a) | | 1LE.....G... 1LA7.....1 | | 2,3,4,5 1 | | ✓ | ✓ | ✓ | ✓ | ✓ |
| IM B14 | | 1LE.....K... 1LA7.....2 | | 2,3,4,5 1 | | ✓ | ✓ | ✓ | ✓ | ✓ |
| Mechanical design and degrees of protection | | | | | | | | | | |
| Condensation drain holes | | 1LE.....Z 1LA7.....Z | | H03 L12 2,3,4,5 1 | | ◇ | ◇ | ◇ | ◇ | ◇ |
| Drive-end seal for flange-mounting motors, oil-tight to 0.1 bar | | 1LE.....Z 1LA7.....Z | | H23 K17 2,3 1 | | ✓ | ✓ | ✓ | ✓ | ✓ |
| Prepared for mountings, center hole only | | 1LE.....Z | | G40 2,3,5 | | - | - | - | - | ✓ 2, 3 - 5 |
| Heating and ventilation | | | | | | | | | | |
| Anti-condensation heating for 230 V | | 1LE.....Z 1LA7.....Z | | Q02 K45 2,3,4,5 1 | | ✓ | ✓ | ✓ | ✓ | ✓ |
| Anti-condensation heating for 115 V | | 1LE.....Z 1LA7.....Z | | Q03 K46 2,3,4,5 1 | | ✓ | ✓ | ✓ | ✓ | ✓ |
| Sheet metal fan cover | | 1LE1.....Z 1LE0..... 1LA7..... | | F74 2, 3 4, 5 1 | | □ | □ | □ 1, 4, 5 ✓ 3 | □ 1, 4, 5 ✓ 3 | ✓ 2, 3 □ 4, 5 |
| Motor protection | | | | | | | | | | |
| Without protection | | 1LE.....A... 1LA7..... | | 2,3,4,5 1 | | □ | □ | □ | □ | □ |
| Motor protection with PTC thermistor with 1 or 3 embedded temperature sensors for tripping (d) | | 1LE.....B... 1LA7.....Z | | A11 2,3,4,5 1 | | ✓ | ✓ | ✓ | ✓ | ✓ |
| Bearing and lubrication | | | | | | | | | | |
| Bearing design for increased cantilever forces | | 1LE.....Z | | L22 2,3,4,5 | | - | - | - | - | ✓ |
| Regreasing device | | 1LE.....Z | | L23 2,3,4,5 | | - | - | - | - | ✓ |
| Packing, safety notes, documentation and certificate | | | | | | | | | | |
| Extra rating plate for voltage tolerance (e) | | 1LE1.....Z 1LE0..... 1LA7.....Z | | B07 B07 2,3 4,5 1 | | ✓ | ✓ | ✓ 1, 3 □ 4, 5 | ✓ 1, 3 □ 4, 5 | ✓ 2, 3 □ 4, 5 |
| Acceptance test certificate 3.1 in accordance with EN 10204 (routine test) | | 1LE.....Z 1LA7.....Z | | B02 B02 2,3,4,5 1 | | ✓ | ✓ | ✓ | ✓ | ✓ |

□ Standard

✓ Option in distribution portfolio

◇ Not available in distribution portfolio, only from standard catalog

- Not available

(a) For canopy as modification, please see chapter 5

(b) Standard for 4-pole and 6-pole motor, optional for 2-pole motor



The most common features are already embedded in our distribution motors, such as metal fan cover, 3 x PTC, etc. In addition you can also enjoy an exclusive package price on 1LE0. When you place the order, you simply add these standard features in the order number according to the option guideline below. Our 1LE0 series already include all embedded features in the basic order number.

| available | | | available | | | | | | available |
|---|---|---|-----------------------------------|-----------------------------------|-----------------------------------|-----------------------------------|-----------------------------------|-----------------------------------|-----------------------------------|
| available | | | available | | | | | | available |
| 112 | 132 | 160 | 180 | 200 | 225 | 250 | 280 | 315 | 355 |
| <input type="checkbox"/> | <input type="checkbox"/> | – | – | – | – | – | – | – | – |
| <input type="checkbox"/> | <input type="checkbox"/> | <input type="checkbox"/> | <input type="checkbox"/> | <input type="checkbox"/> | <input type="checkbox"/> | <input type="checkbox"/> | <input type="checkbox"/> | <input type="checkbox"/> | <input type="checkbox"/> |
| ✓ | ✓ | – | – | – | – | – | – | – | – |
| ✓ | ✓ | ✓ | ✓ | ✓ | ✓ | ✓ | ✓ | ✓ | ✓ |
| ✓ | ✓ | – | – | – | – | – | – | – | – |
| ✓ | ✓ | ✓ | ✓ | ✓ | ✓ | ✓ | ✓ | ✓ | ✓ |
| ✓ | ✓ | ✓ | ✓ | ✓ | ✓ | ✓ | ✓ | ✓ | ✓ |
| <input type="checkbox"/> | <input type="checkbox"/> | <input type="checkbox"/> | <input type="checkbox"/> | <input type="checkbox"/> | <input type="checkbox"/> | <input type="checkbox"/> | <input type="checkbox"/> | <input type="checkbox"/> | <input type="checkbox"/> |
| ✓ | ✓ | ✓ | ✓ | ✓ | ✓ | ✓ | ✓ | ✓ | ✓ |
| ✓ | ✓ | ✓ | ✓ | ✓ | ✓ | ✓ | ✓ | ✓ | – |
| ✓ | ✓ | ✓ | ✓ | ✓ | ✓ | ✓ | ✓ | ✓ | ✓ |
| ✓ | ✓ | ✓ | – | – | – | – | – | – | – |
| $\diamond 2, 3$ $\square 4, 5$ | $\diamond 2, 3$ $\square 4, 5$ | $\diamond 2, 3$ $\square 4, 5$ | <input type="checkbox"/> | <input type="checkbox"/> | <input type="checkbox"/> | <input type="checkbox"/> | <input type="checkbox"/> | <input type="checkbox"/> | <input type="checkbox"/> |
| ✓ | ✓ | ✓ | – | – | – | – | – | – | – |
| $\checkmark 2, 3$ $\square 5$ | $\checkmark 2, 3$ $\square 5$ | $\checkmark 2, 3$ $\square 5$ | <input type="checkbox"/> 5 | <input type="checkbox"/> 5 | <input type="checkbox"/> 5 | <input type="checkbox"/> 5 | <input type="checkbox"/> 5 | <input type="checkbox"/> 5 | <input type="checkbox"/> 5 |
| ✓ | ✓ | ✓ | ✓ | ✓ | ✓ | ✓ | ✓ | ✓ | ✓ |
| ✓ | ✓ | ✓ | ✓ | ✓ | ✓ | ✓ | ✓ | ✓ | ✓ |
| $\checkmark 2, 3$ $\square 4, 5$ | $\checkmark 2, 3$ $\square 4, 5$ | $\checkmark 2, 3$ $\square 4, 5$ | <input type="checkbox"/> | <input type="checkbox"/> | <input type="checkbox"/> | <input type="checkbox"/> | <input type="checkbox"/> | <input type="checkbox"/> | <input type="checkbox"/> |
| <input type="checkbox"/> | <input type="checkbox"/> 2, 3, 4 – 5 | <input type="checkbox"/> 2, 3, 4 – 5 | <input type="checkbox"/> 4 – 5 | <input type="checkbox"/> 4 – 5 | <input type="checkbox"/> 4 – 5 | <input type="checkbox"/> 4 – 5 | <input type="checkbox"/> 4 – 5 | <input type="checkbox"/> 4 – 5 | <input type="checkbox"/> 4 – 5 |
| ✓ | $\checkmark 2, 3, 4$ $\square 5$ | $\checkmark 2, 3, 4$ $\square 5$ | $\checkmark 4$ $\square 5$ | $\checkmark 4$ $\square 5$ | $\checkmark 4$ $\square 5$ | $\checkmark 4$ $\square 5$ | $\checkmark 4$ $\square 5$ | $\checkmark 4$ $\square 5$ | $\checkmark 4$ $\square 5$ |
| $\checkmark 2, 3, 4$ $\square 5^{(b)}$ | $\checkmark 2, 3, 4$ $\square 5^{(b)}$ | $\checkmark 2, 3, 4$ $\square 5^{(b)}$ | ✓ | ✓ | ✓ | ✓ ^(c) | ✓ ^(c) | ✓ ^(c) | ✓ ^(c) |
| ✓ | ✓ | ✓ | ✓ | ✓ | ✓ | ✓ | <input type="checkbox"/> | <input type="checkbox"/> | <input type="checkbox"/> |
| $\checkmark 2, 3$ $\square 4, 5$ | $\checkmark 2, 3$ $\square 4, 5$ | $\checkmark 2, 3$ $\square 4, 5$ | <input type="checkbox"/> | <input type="checkbox"/> | <input type="checkbox"/> | <input type="checkbox"/> | <input type="checkbox"/> | <input type="checkbox"/> | <input type="checkbox"/> |
| ✓ | ✓ | ✓ | ✓ | ✓ | ✓ | ✓ | ✓ | ✓ | ✓ |

(c) Not available for construction type IM V1

(d) For 1LE10 motors, frame sizes 80 and 90, there is only 1 embedded PTC

(e) Option B07 is standard for 400 V version only



Did you know

Power

Power is the work performed in a unit of time, measured in W (Watt).

Dimensions:

1 W = J/s (1 Joule per second)
 = 1 Nm/s (1 Newton meter per second)
 = 1 kgm²/s³
 = 0.102 kpm/s
 1 kW = 1.36 HP

The following applies to three-phase motors:

$$P_N = \sqrt{3} \cdot V_{\text{supply}} \cdot I_{\text{supply}} \cdot \eta \cdot \cos\varphi$$

P_N Rated power in W
 V Rated voltage in V
 I Line current in A
 η Efficiency
 $\cos\varphi$ Power factor

The rated power is one of the most important parameters of a motor. According to DIN 42673 – and maintaining the regulations according to VDE 0530 – the individual motor frame sizes are assigned specific power ratings for continuous duty S1. Different operating conditions or different duty types generally result in a change in the rated power.



Did you know

Torque

Torque is generated by the effect of force applied to a lever arm. This is the product of force multiplied by the vertical distance from the axis of rotation; for belt drives, e.g. circumferential force multiplied by the radius of the belt pulley.

$$M = 9.55 \cdot P \cdot \frac{1000}{n}$$

M Torque in Nm
 P Power in kW
 n Speed in rpm



Did you know

Speed

The synchronous speed n_s (rpm) of a three-phase induction motor is obtained from the line frequency f and the pole pair number p (4-pole $\rightarrow 2p = 4$).

$$n_s = \frac{120 \cdot f}{2 \cdot p}$$

When connected to a 50 Hz line supply, a 2p = 4-pole motor has a synchronous speed of

$$\frac{120 \cdot 50}{4} = 1500 \text{ rpm}$$

The synchronous speeds of the generally used 2, 4, and 6-pole motors are correspondingly obtained

- at a line frequency of 50 Hz
3000, 1500, 1000 rpm
- at a line frequency of 60 Hz
3600, 1800, 1200 rpm

The rotor of a three-phase induction motor rotates with a lower speed (with slip) than the rotating field.

Slip s is calculated according to the following formula:

$$s = \frac{n_s - n}{n} \cdot 100$$

s Slip as a %
 n_s Synchronous speed in rpm
 n Rotor speed in rpm

The rated slip s_N is correspondingly calculated. The rotor losses of the motor are approximately proportional to the slip. The objective is to achieve a low rated slip in order to achieve a good efficiency.

The rated slip depends on the motor size. For instance, for small motors, it is approx. 10 % and for large motors, approx. 1 %.

Notes

Special features detail

Efficiency

Efficiency classes and efficiencies according to IEC 60034-30:2008

Harmonization of the efficiency classes

Different energy efficiency standards exist worldwide for induction motors. To promote international harmonization, the international standard IEC 60034-30:2008 (Rotating electrical machines – Part 30: Efficiency classes of single-speed, three-phase, cage-induction motors (IE code)) was created. This groups low-voltage asynchronous motors into new efficiency classes (valid since October 2008). The efficiencies of IEC 60034-30:2008 are based on losses determined in accordance with the IEC 60034-2-1:2007 standard. This has been valid since November 2007 and has been replacing the standard IEC 60034-2:1996 since November 2010. The supplementary losses are now measured and no longer added as a percentage.

IE efficiency classes

The efficiency classes are grouped according to the following nomenclature (IE = International Efficiency):

- IE1 (Standard Efficiency)
- IE2 (High Efficiency)
- IE3 (Premium Efficiency)
- IE4 (Super Premium Efficiency)

Measuring method according to IEC 60034-2-1:2007 for determining the efficiency

With the measuring method, the supplementary losses are no longer applied as a percentage, but instead they are determined with measurements (IEC 60034-2-1: 2007). The nominal efficiencies are therefore reduced from EFF1 to IE2 and from EFF2 to IE1, even though there have been no technical or physical changes to the motors.

Previously: $P_{LL} = 0.5\%$ of P added

Now: $P_{LL} =$ Individual measurement

$P_{LL} =$ Load-dependent supplementary losses

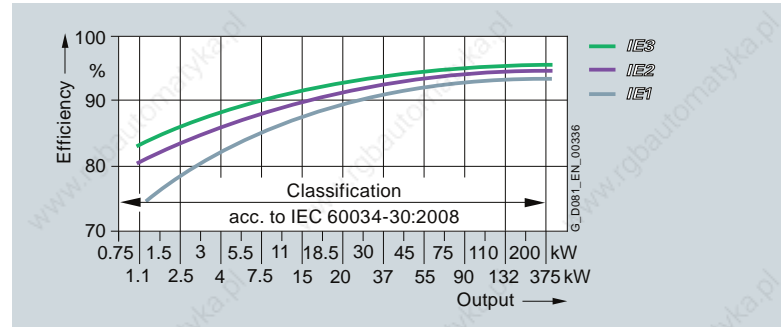

IE1 to IE3 efficiencies 4-pole 50 Hz

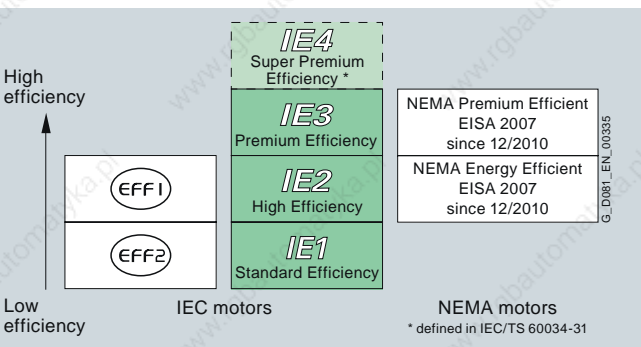

IE efficiency classes in accordance with the output

The following table shows examples of the efficiency values according to the current and previous loss calculating methods.

| | EFF measuring method (incl. percentage losses) according to EN/IEC 60034-2: 1996 50 Hz | Losses determined according to IEC 60034-2-1: 2007 50 Hz | Losses determined according to IEC 60034-2-1: 2007 60 Hz |
|---------------|--|--|--|
| 5.5 kW 4-pole | 89.2 % | 87.7 % | 89.5 % |
| 45 kW 4-pole | 93.9 % | 93.1 % | 93.6 % |
| 110 kW 4-pole | Not defined | 94.5 % | 95.0 % |

Background information

Comprehensive laws have been introduced in the European Union with the objective of reducing energy consumption and therefore CO₂ emissions. EU Directive 640/2009 concerns the energy consumption or efficiency of induction motors in the industrial environment. This Directive is now in force in every country of the European economic area. For further details on internationally applicable standards and legal requirements, visit:

- www.siemens.com/international-efficiency
- www.siemens.com/energysaving
- www.siemens.com/sinasave



We comply with the latest efficiency standards and describe motors for both the IE1 and IE2 efficiencies. Although Siemens also has ranges for IE3 and specific solutions for IE4 efficiency, these are still considered specialized and are not described in this document. In addition to these general IE1 and IE2 solutions, Siemens can also provide specific variants for specific markets i.e. in India, Korea, China etc. In such instances please consult your local Siemens representative.



Did you know

The better the efficiency of a motor, the lower the internal heat loss. The lower the heat loss, the lower the temperature rise. Higher efficiency IE2 motors run cooler than same size IE1 motors. That increases the electrical life expectancy of an IE2 motor.

The most important changes at a glance:

| | | |
|------------------------------|---|--|
| | CEMEP voluntary EU agreement | EU Directive No. 640/2009 adopted on July 22, 2009 based on the IEC 60034-30 standard |
| Description | Voluntary agreement between the EU commission and the European sector committee of manufacturers of electrical machines (CEMEP) | The EU Directive is in force in every country of the EU. Losses are determined and therefore the efficiency is determined in accordance with IEC 60034-2-1:2007 |
| Number of poles | 2, 4 | 2, 4, 6 |
| Power range | 1.1 ... 90 kW | 0.75 ... 375 kW |
| Level | EFF3 – Standard – EFF3 EFF2 – Enhanced efficiency EFF1 – Highly efficient | IE1 – Standard Efficiency IE2 – High Efficiency IE3 – Premium Efficiency |
| Voltage | 400 V, 50 Hz | < 1000 V, 50/60 Hz |
| Degree of protection | IP5X | All |
| Motors equipped with a brake | NO | In agreement |
| Geared motors | NO | YES |
| Ex motors | NO | EU Directive – NO IEC 60034-30 – YES (but explosion protection always has a higher priority) |
| Validity | Voluntary agreement; will be replaced on implementation | IEC 60034-30 standard, valid since October 2008; the EU Directive will come into force on June 16, 2011. This means that as of this date, manufacturers are no longer permitted to place IE1 motors on the market in the European economic area. |

Exceptions to the EU Directive

- Motors that are designed to be operated totally submerged in a liquid;
- Motors fully integrated into a product (e.g. a gear unit, pump, fan or compressor) whose energy efficiency cannot be measured independently of the product;
- Motors that are specially designed for operation under the following conditions:
 - At altitudes greater than 1000 meters above sea level;
 - At ambient temperatures above 40 °C;
 - At maximum operating temperatures above 400 °C;
 - At ambient temperatures below -15 °C (any motor)
 - With cooling liquid temperatures at the product intake of below 5 °C or above 25 °C;
 - In hazardous areas in the context of Directive 94/9/EC of the European Parliament and Council;
- Brake motors

The following motors are not involved:

- 8-pole motors
- Pole-changing motors
- Synchronous motors
- Motors for intermittent duty S2 to S9
- Single-phase motors
- Motors specially developed for converter-fed operation in accordance with IEC 60034-25

The changes are applicable starting the following dates:

June 16, 2011:

Compliance with the legally required minimum efficiency class IE2 for induction motors in S1 operation in accordance with EU Directive

January 1, 2015:

Compliance with the legally required minimum efficiency class IE3 for outputs from 7.5 to 375 kW or, as an alternative, IE2 motor plus frequency converter

January 1, 2017:

Compliance with the legally required minimum efficiency class IE3 for outputs from 0.75 to 375 kW or, as an alternative, IE2 motor plus frequency converter

IP rating

The IP Code (or Ingress Protection Rating, sometimes also interpreted as International Protection Rating) consists of the letters IP followed by two digits or one digit and one letter and an optional letter. As defined in [international standard IEC 60529](#), IP Code classifies and rates the degrees of protection provided against the intrusion of solid objects, dust, accidental contact, and water in mechanical casings and with electrical enclosures.

| | | | |
|----|---|---|---|
| IP | 5 | 5 | |
| | | | Code number indicating protection against water |
| | | | Code number indicating touch protection and protection against foreign bodies |
| | | | International Protection |

TIP



Some manufacturers offer sealing and protection above IP55. Although it is available as an option, Siemens prefers a true IP55 as a default standard.

- IP55 covers the vast majority of applications as it offers dust and rain protection
- The IP55 is stable over the life of the motor. Higher protections can need maintenance or an exact assembly to ensure that the higher protection is real and not just on paper.
- Modifications can be made on an IP55 motor whilst maintaining that degree of protection.

Solids, first digit

The first digit indicates the level of protection that the enclosure provides against access to hazardous parts (e.g., electrical conductors, moving parts) and the ingress of solid foreign objects.

| Level | Object size protected against | Effective against |
|-------|-------------------------------|--|
| 0 | – | No protection against contact and ingress of objects |
| 1 | >50 mm | Any large surface of the body, such as the back of a hand, but no protection against deliberate contact with a body part |
| 2 | >12.5 mm | Fingers or similar objects |
| 3 | >2.5 mm | Tools, thick wires, etc. |
| 4 | >1 mm | Most wires, screws, etc. |
| 5 | Dust protected | Ingress of dust is not entirely prevented, but it must not enter in sufficient quantity to interfere with the satisfactory operation of the equipment; complete protection against contact |
| 6 | Dust tight | No ingress of dust; complete protection against contact |

TIP



A suitable degree of protection should be selected depending on the operating and environmental conditions. Siemens offers a standard which is most suitable and applicable over the lifetime of a motor such as true IP55 standard.

Liquids, second digit

Protection of the equipment inside the enclosure against harmful ingress of water.

| Level | Protected against | Testing for | Details |
|-------|--------------------------------------|--|--|
| 0 | Not protected | – | – |
| 1 | Dripping water | Dripping water (vertically falling drops) shall have no harmful effect. | Test duration: 10 minutes Water equivalent to 1 mm rainfall per minute |
| 2 | Dripping water when tilted up to 15° | Vertically dripping water shall have no harmful effect when the enclosure is tilted at an angle up to 15° from its normal position. | Test duration: 10 minutes Water equivalent to 3 mm rainfall per minute |
| 3 | Spraying water | Water falling as a spray at any angle up to 60° from the vertical shall have no harmful effect. | Test duration: 5 minutes Water volume: 0.7 liters per minute Pressure: 80–100 kN/m ² |
| 4 | Splashing water | Water splashing against the enclosure from any direction shall have no harmful effect. | Test duration: 5 minutes Water volume: 10 liters per minute Pressure: 80–100 kN/m ² |
| 5 | Water jets | Water projected by a nozzle (6.3 mm) against enclosure from any direction shall have no harmful effects. | Test duration: at least 3 minutes Water volume: 12.5 liters per minute Pressure: 30 kN/m ² at distance of 3 m |
| 6 | Powerful water jets | Water projected in powerful jets (12.5 mm nozzle) against the enclosure from any direction shall have no harmful effects. | Test duration: at least 3 minutes Water volume: 100 liters per minute Pressure: 100 kN/m ² at distance of 3 m |
| 7 | Immersion up to 1 m | Ingress of water in harmful quantity shall not be possible when the enclosure is immersed in water under defined conditions of pressure and time (up to 1 m of submersion). | Test duration: 30 minutes Immersion at depth of 1 m |
| 8 | Immersion beyond 1 m | The equipment is suitable for continuous immersion in water under conditions which shall be specified by the manufacturer. Normally, this will mean that the equipment is hermetically sealed. However, with certain types of equipment, it can mean that water can enter but only in such a manner that it produces no harmful effects. | Test duration: continuous immersion in water Depth specified by manufacturer |

Thermal class

The Siemens motors are rated at normal sinusoidal voltage with a class B (130 °C) temperature rise. The windings are rated to class F (155 °C) thus allowing for reserve for the additional losses associated with variable speed drive operation and/or higher ambient temperature and/or overload conditions.

The temperature rise of the winding of the motor is important. It provides a great insight into the design of the motor and its life expectancy. The cooler a motor runs the better its life expectancy and longer its life. Siemens builds motors to a minimum of Class F (155 °C) on all material – continuous operation for a very long life expectancy.

- Class B (130 °C) is the normal utilization – even better.
- Class H (180 °C) is reserved for special application motors.
- Class H motors are considered detrimental for normal use due to the degradation of the overall life expectancy of paint and bearings.
- At class H the outside surface temperature can exceed an unsafe 100 °C.

The more efficient the motor, the less heat it produces – to the extent that modern motors often only run with internal temperatures of 95 °C – much cooler than the limits set by the standards.

Siemens uses double coated wires with DURIGNIT insulation materials and capable varnishes – we consider all components including electrical connections and bearing grease – our motors are true class F under all circumstances – with reserve built in on top.

A claim to class H could be made but that would not reflect the true life expectancy which you would expect.

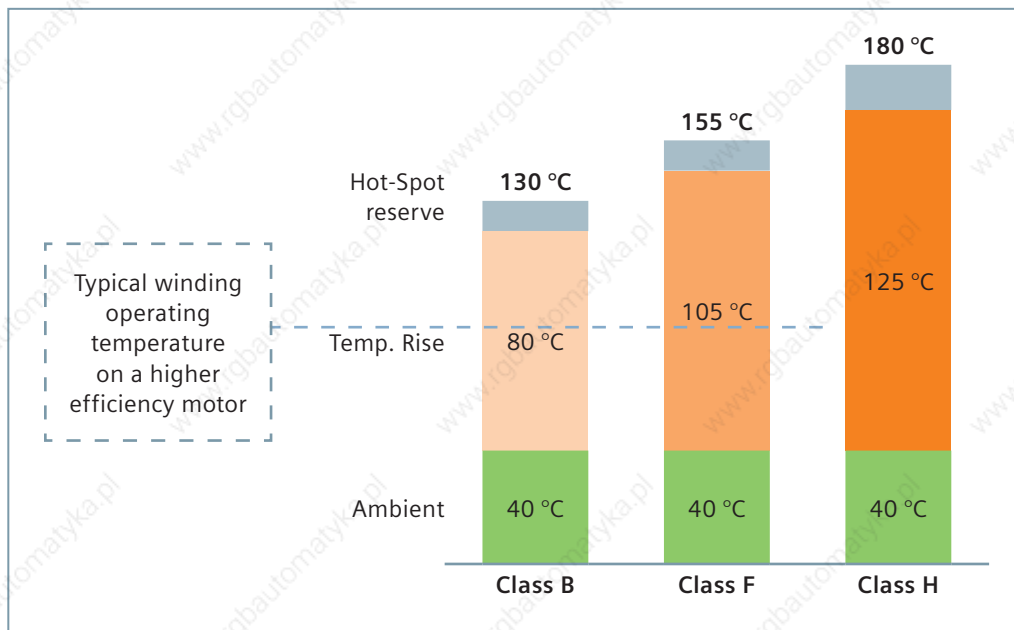

TIP

Siemens builds motors with reserve: The motors are capable to operate at least at 155 °C (Class F) but we only rate at a nominal 130 °C (Class B).

- An IE1 motor can be operated at 10% overload or at 50 °C ambient temperature.
- An IE2 motor can be operated at 15% overload or at 55 °C ambient temperature.

Did you know

Although Siemens uses class H wire, we do not rate our motors for class H operation. The electrical life expectancy at class F is four times greater than at class H. If used at class B or cooler 400.000 hours and more are not exceptional.

High efficiency motors in IE2 do not generate the amount of heat to reach thermal class H.

Derating

Environmental

- Degree of motor protection IP55 (IEC 60034-5).
- Altitude shall not exceed 1000 m above sea-level (IEC 60034-1).
- Allowed air temperature between -20 °C and 40 °C (IEC 60034-1).
- Permitted relative humidity:
 - -20 °C ≤ T ≤ 20 °C: 100 %
 - 20 °C < T ≤ 30 °C: 95 %
 - 30 °C < T ≤ 40 °C: 55 %

For higher coolant temperatures and / or site altitudes higher than 1000 m above sea level, the specified motor must be reduced by using the factor k_{HT} . This results in an admissible output (P_{adm}) of the motor:

$$P_{adm} = P_{rated} \cdot k_{HT}$$

Reduction factor k_{HT} for different site altitudes and / or coolant temperature

| Site altitude above sea level m | Ambient temperature/coolant temperature | | | | | |
|------------------------------------|---|------------|-------|-------|-------|-------|
| | < 30 °C | 30 ~ 40 °C | 45 °C | 50 °C | 55 °C | 60 °C |
| 1000 | 1.07 | 1.00 | 0.96 | 0.92 | 0.87 | 0.82 |
| 1500 | 1.04 | 0.97 | 0.93 | 0.89 | 0.84 | 0.79 |
| 2000 | 1.00 | 0.94 | 0.90 | 0.86 | 0.82 | 0.77 |
| 2500 | 0.96 | 0.90 | 0.86 | 0.83 | 0.78 | 0.74 |
| 3000 | 0.92 | 0.86 | 0.82 | 0.79 | 0.75 | 0.70 |
| 3500 | 0.88 | 0.82 | 0.79 | 0.75 | 0.71 | 0.67 |
| 4000 | 0.82 | 0.77 | 0.74 | 0.71 | 0.67 | 0.63 |

Note:

If operating conditions exceed above values, please contact our local sales office for the selection of catalog motors.

Anti-condensation

Moisture is present in the air around us. Under the correct circumstances it can condensate. The warmer the air the higher the possible moisture content. As air cools the moisture carrying content reduces to the point when the moisture condenses – called the "Dew-Point".

This condition can be met several times a day under normal operation, as a motor operates and cools at differing times of the day.

Smaller motors are less susceptible than larger motors due to the smaller volume of moist air possible in the motor. Dew moisture condenses and accumulates in a motor, which is seen as water collection. The water accumulates at the lowest point of the motor. It often does no harm as long as the collection point is below the level of the electrical system.

Two points that need to be paid attention to are, first, how much water there is in the air and when it will condensate. The second is, whether it will do any harm.

| Relative humidity | Temperature | | | | | | | | |
|-------------------|-------------|-------|-------|-------|-------|-------|-------|-------|--|
| | 20 °C | 30 °C | 40 °C | 50 °C | 60 °C | 70 °C | 80 °C | 90 °C | |
| 10% | 2 | 3 | 5 | 8 | 13 | 20 | 29 | 42 | |
| 15% | 3 | 5 | 8 | 12 | 19 | 30 | 44 | 63 | |
| 20% | 3 | 6 | 10 | 17 | 26 | 39 | 58 | 84 | |
| 25% | 4 | 8 | 13 | 21 | 32 | 49 | 73 | 105 | |
| 30% | 5 | 9 | 15 | 25 | 39 | 59 | 87 | 126 | |
| 35% | 6 | 11 | 18 | 29 | 45 | 69 | 102 | 146 | |
| 40% | 7 | 12 | 20 | 33 | 52 | 79 | 116 | 167 | |
| 45% | 8 | 14 | 23 | 37 | 58 | 89 | 131 | 188 | |
| 50% | 9 | 15 | 26 | 41 | 65 | 98 | 145 | 209 | |
| 55% | 10 | 17 | 28 | 46 | 71 | 108 | 160 | 230 | |
| 60% | 10 | 19 | 31 | 50 | 78 | 118 | 174 | 251 | |
| 65% | 11 | 20 | 33 | 54 | 84 | 128 | 189 | 272 | |
| 70% | 12 | 21 | 36 | 58 | 91 | 138 | 203 | 293 | |
| 75% | 13 | 23 | 38 | 62 | 97 | 148 | 218 | 314 | |
| 80% | 14 | 24 | 41 | 66 | 104 | 157 | 233 | 335 | |
| 85% | 15 | 26 | 43 | 70 | 110 | 167 | 247 | 356 | |
| 90% | 16 | 27 | 46 | 74 | 117 | 177 | 262 | 377 | |
| 95% | 16 | 29 | 49 | 79 | 123 | 187 | 276 | 398 | |
| 100% | 17 | 30 | 51 | 83 | 130 | 197 | 291 | 419 | |

If operating conditions exceed temperatures of 60 °C, please contact our local sales office for the selection of catalog motors.

Table showing the weight of moisture contained in the air, given as g/m³.

The local temperature is on the x axis and the local relative humidity is shown on the Y axis.

Blue fields show normal conditions.

Yellow fields show higher moisture – for motors FS ≥112 a drain hole is recommended.

For orange colored fields a drain hole is recommended and for more important motors a heating is also recommended (separate space heater of winding heating).



TIP In humid climates, during motor cool down the air inside contracts, pulling in fresh, warm, humid air. This humidity condensates inside the motor, forming water droplets. Those water droplets have to drain.

Therefore on many motors, especially the larger ones, Siemens has foreseen drain holes as standard.

Anti-condensation

Anti-condensation heating can be provided for motors where there is a danger that moisture condensation will form on the winding due to the climatic situation. This anti-condensation heater warms up the air in the motor to a temperature above the dew point temperature in order to prevent condensation forming inside the motor. The anti-condensation heating must not be switched on while the motor is operational.

Graphic showing the temperature at which the moisture in the air will condensate to water. The lines on the left show the local temperature. The x-axis gives the local relative humidity. The "dew Point" temperature can be read on the Y-axis.

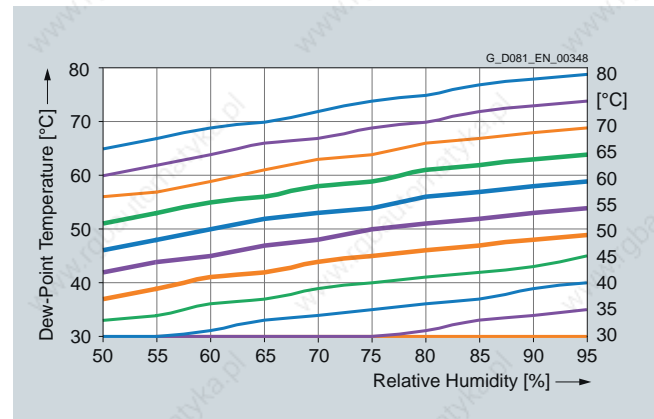

TIP



Another possible solution is to connect a voltage to the stator terminals U1 and V1 that should be between 4 and 10% of the rated motor voltage. Approximately 20 to 30% of the rated current is sufficient in order to achieve an adequate temperature rise to avoid condensation.

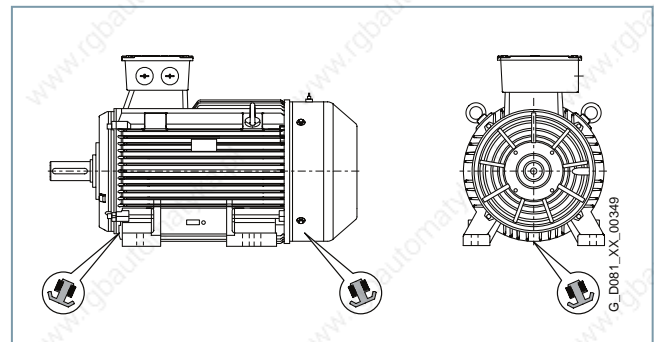

Drain hole location

Motor protection

PTC thermistor temperature sensors are predominantly used for thermistor motor protection devices (alarm or shutdown) for motors. These thermistors are generally integrated in the winding overhang. As a consequence, the stator winding is directly protected. The temperature difference between alarm and shutdown (trip) is 10 K.

When a limit temperature is reached (nominal tripping temperature), the resistance of PTC thermistors will have a step change. This is evaluated by a tripping unit and can be used to open auxiliary circuits.

Thermal protection with PTC thermistors with 3 embedded temperature sensors for tripping is provided in our IE2 motors above frame size 112 as standard version. Anyhow it can be selected as an option for our IE1 motors and IE2 motors with frame size less than 132. Connection can be done through 2 auxiliary terminals in the terminal box.

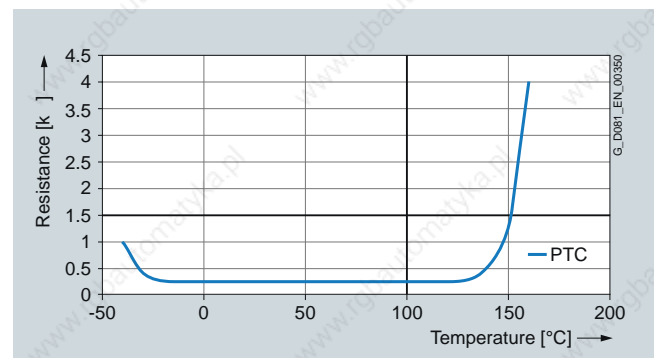

Note:

The PTC thermistors themselves cannot be subjected to high currents and voltages. This would result in destruction of the semiconductor. The switching hysteresis of the PTC thermistor and tripping unit is low, which supports fast restarting of the drive. Motors with this type of protection are recommended for heavy duty starting, switching duty, extreme changes in load, high ambient temperatures or fluctuating supply systems.

TIP



3 x PTC have already been embedded in our 1LE0 IE2 motors as standard version.

Converter-fed application

The insulation system of our motors is capable for converter-fed operation as standard.
 For sinusoidal (mains) supplies 690 V_{rms} 50 Hz with:
 phase to phase 1200 V_{rms} capability
 phase to ground 900 V_{rms} capability
 For converter-fed operation, as standard:
 460 V_{rms} max. Frequency limited by motor maximum speed 5000 V/μs

Converter-fed application

Our motors are suitable for pumps, fans, compressors, textile machine and mechanical machine applications where variable or constant speed is required.

In applications where the motor is driven by a converter, the degree of electrical interference depends on the type of converter used (type, number of IGBTs, interference suppression measures, and manufacturer), cabling, distance and application requirements. The installation guidelines of the converter manufacturer with regards to electromagnetic compatibility must be considered at all times during the design and implementation phases.

At rated output with converter-fed operation, the motors will be used in temperature class 155 (F). To prevent damage as a result of bearing currents, insulated bearings are recommended to be assembled for frame size 250 and above. Please inquire Siemens about the detailed information of insulated bearing.

Converter-fed operation

The standard insulation of our motors is designed such that operation is possible on the converter at mains voltage up to 460 V.

Our motors are capable for converter-fed operation with certain characteristics load, of which the load torque characteristics is referred in the following diagram:

Voltage (peak and gradient) withstand levels

The dielectric stress of the winding insulation is determined by:

- the peak voltage, rise time and frequency of the impulses produced by the converter.
- the characteristics and the length of the connection leads between the converter and motor.
- the winding construction and other system parameters, especially the voltages between the different parts of the winding and the ground represent dielectric stress at the insulation system.

TIP

These motors do not have a special series for converter-fed operation – they are suited as standard. On-line or converter-fed operation.

The standard insulation of our motors is designed to withstand voltage peak and gradient which is showed in the diagram:

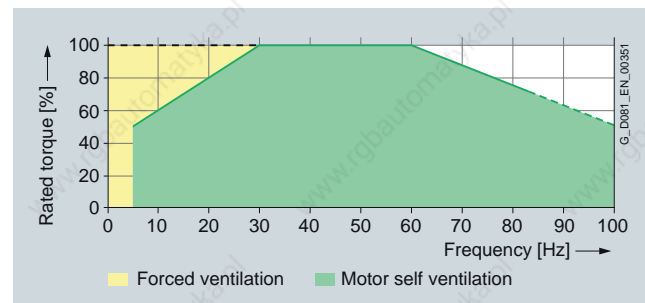

By usage with admissible torque and below, the motor can be operated with self cooling; by usage over the admissible torque line, the motor with forced ventilation is needed. At operating speeds above rated speed the noise and vibration levels increase and the bearing lifetime reduces. Attention should be paid to the re-greasing intervals and the grease service life. For converter-fed operation with frequencies greater than 60 Hz special balancing is required for compliance with the specified limit values.

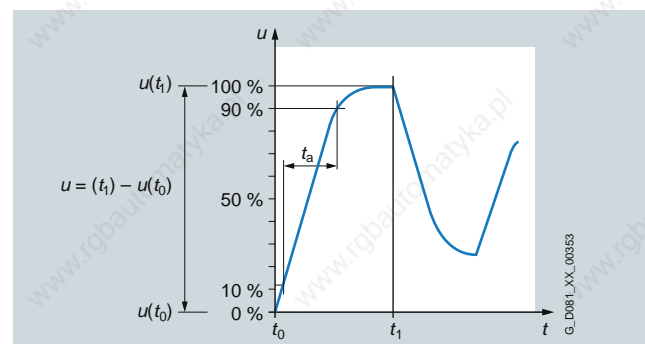
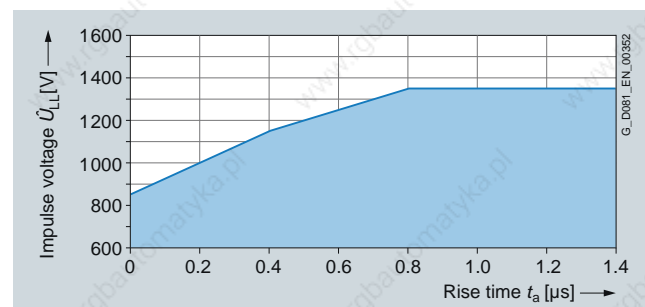

Did you know

As the motor gets larger so does the internal surface area between the stator and rotor. That surface has a stray capacitance which can lead to a voltage on the shaft – and that voltage can lead to bearing failure (bearing currents). The situation is aggravated by converter-fed operation. Siemens recommends the use of insulated bearings for motors of frame size ≥ 250 . The insulated bearing as an option can be supplied out of our standard catalog portfolio D81.1 and on request for the 1LE0 series.

Converter-fed application

| SIMOTICS General Purpose | | | | | | | | | | | |
|--------------------------|-----------------|-----------------------|------------------|-----------------------|------------------|-----------------------|------------------|-----------------------|------------------|-----------------------|------------------|
| Frame size | Number of poles | Aluminum Series | | | | | | Cast Iron Series | | | |
| | | Efficiency IE1 | | Efficiency IE2 | | Efficiency IE1 | | Efficiency IE2 | | Efficiency IE2 | |
| | | 1LA7 | 1LE1002 | 1LE1001 | 1LE1002 | 1LE1001 | 1LE1012 | 1LE1011 | 1LE1012 | 1LE1011 | |
| | | max. mechanical speed | f _{max} | max. mechanical speed | f _{max} | max. mechanical speed | f _{max} | max. mechanical speed | f _{max} | max. mechanical speed | f _{max} |
| 63 | 2 | 6000 | 100 | 6000 | 100 | - | - | - | - | - | - |
| | 4 | 4200 | 140 | 4200 | 140 | - | - | - | - | - | - |
| | 6 | 3600 | 180 | 3600 | 180 | - | - | - | - | - | - |
| 71 | 2 | 6000 | 100 | 6000 | 100 | - | - | - | - | - | - |
| | 4 | 4200 | 140 | 4200 | 140 | - | - | - | - | - | - |
| | 6 | 3600 | 180 | 3600 | 180 | - | - | - | - | - | - |
| 80 | 2 | 6000 | 100 | 6000 | 100 | 6000 | 100 | 5200 | 87 | 5200 | 87 |
| | 4 | 4200 | 140 | 4200 | 140 | 4200 | 140 | 3600 | 120 | 3600 | 120 |
| | 6 | 3600 | 180 | 3600 | 180 | 3600 | 180 | 2400 | 120 | 2400 | 120 |
| 90 | 2 | 6000 | 100 | 6000 | 100 | 6000 | 100 | 5200 | 87 | 5200 | 87 |
| | 4 | 4200 | 140 | 4200 | 140 | 4200 | 140 | 3600 | 120 | 3600 | 120 |
| | 6 | 3600 | 180 | 3600 | 180 | 3600 | 180 | 2400 | 120 | 2400 | 120 |
| 100 | 2 | - | - | 6000 | 100 | 6000 | 100 | 5200 | 87 | 5200 | 87 |
| | 4 | - | - | 4200 | 140 | 4200 | 140 | 3600 | 120 | 3600 | 120 |
| | 6 | - | - | 3600 | 180 | 3600 | 180 | 2400 | 120 | 2400 | 120 |
| 112 | 2 | - | - | 6000 | 100 | 6000 | 100 | 5200 | 87 | 5200 | 87 |
| | 4 | - | - | 4200 | 140 | 4200 | 140 | 3600 | 120 | 3600 | 120 |
| | 6 | - | - | 3600 | 180 | 3600 | 180 | 2400 | 120 | 2400 | 120 |
| 132 | 2 | - | - | 5600 | 93 | 5600 | 93 | 4500 | 75 | 4500 | 75 |
| | 4 | - | - | 4200 | 140 | 4200 | 140 | 2700 | 90 | 2700 | 90 |
| | 6 | - | - | 3600 | 180 | 3600 | 180 | 2400 | 120 | 2400 | 120 |
| 160 | 2 | - | - | 4800 | 80 | 4800 | 80 | 4500 | 75 | 4500 | 75 |
| | 4 | - | - | 4200 | 140 | 4200 | 140 | 2700 | 90 | 2700 | 90 |
| | 6 | - | - | 3600 | 180 | 3600 | 180 | 2400 | 120 | 2400 | 120 |
| 180 | 2 | - | - | - | - | - | - | 4500 | 75 | 4500 | 75 |
| | 4 | - | - | - | - | - | - | 2700 | 90 | 2700 | 90 |
| | 6 | - | - | - | - | - | - | 2400 | 120 | 2400 | 120 |
| 200 | 2 | - | - | - | - | - | - | 4500 | 75 | 4500 | 75 |
| | 4 | - | - | - | - | - | - | 2300 | 77 | 2300 | 77 |
| | 6 | - | - | - | - | - | - | 1800 | 90 | 1800 | 90 |
| 225 | 2 | - | - | - | - | - | - | 3600 | 60 | 3600 | 60 |
| | 4 | - | - | - | - | - | - | 2300 | 77 | 2300 | 77 |
| | 6 | - | - | - | - | - | - | 1800 | 90 | 1800 | 90 |
| 250 | 2 | - | - | - | - | - | - | 3600 | 60 | 3600 | 60 |
| | 4 | - | - | - | - | - | - | 2300 | 77 | 2300 | 77 |
| | 6 | - | - | - | - | - | - | 1800 | 90 | 1800 | 90 |
| 280 | 2 | - | - | - | - | - | - | 3600 | 60 | 3600 | 60 |
| | 4 | - | - | - | - | - | - | 2300 | 77 | 2300 | 77 |
| | 6 | - | - | - | - | - | - | 1800 | 90 | 1800 | 90 |
| 315 | 2 | - | - | - | - | - | - | 3600 | 60 | 3600 | 60 |
| | 4 | - | - | - | - | - | - | 2300 | 77 | 2300 | 77 |
| | 6 | - | - | - | - | - | - | 1800 | 90 | 1800 | 90 |
| 355 | 2 | - | - | - | - | - | - | 3600 | 60 | 3600 | 60 |
| | 4 | - | - | - | - | - | - | 2300 | 77 | 2300 | 77 |
| | 6 | - | - | - | - | - | - | 1800 | 90 | 1800 | 90 |

Mechanical stress and grease lifetime (converter-fed operation).

High speeds that exceed the rated speed and the resulting increased vibrations alter the mechanical running smoothness and the bearings are subject to increased mechanical stress. This reduces the grease lifetime and the bearing lifetime. More detailed information on request.

Ventilation/noise generation (converter-fed operation).

The fan noise can increase at speeds that are higher than the rated speed of self-ventilated motors. To increase motor utilization at low speeds it is recommended that forced ventilated motors are used.

Mechanical limit speeds

When the motor is operated at its rated frequency, it is important to note that the maximum speeds are limited by the limits for the roller bearings, critical rotor speed and rigidity of the rotating parts.

All the data listed in the brochure is applicable for a 50 Hz line supply. With converter-fed operation, the reduction factors for constant torque and drives for fans, pumps and compressors must be observed.



TIP

By use of converter-fed operation, motors can run at speeds higher than 50 Hz or 60 Hz nominal speed. High speeds that exceed the rated speed of a motor can lead to increased vibration and substantially decrease the life expectancy of the bearings. The maximum mechanical speed of a motor must not be exceeded due to risk of failure. More detailed information on request.

Noise

Motors are often used in applications in which noise is a primary concern. The use of converters can excite the surfaces of motors and sound of diverse frequencies can be resonate in the cooling channels.

Siemens has addressed this issue but modifying the core design.

Surfaces, shapes and materials and air channels have been optimised. The result is a motor which is quieter, especially with converter-fed operation.

| Output (kW) | Aluminum Series | | | | |
|-------------|-------------------|------------------------|-------------------|-------------------|---------------------------|
| | Efficiency IE1 | | | | |
| | 3000 rpm (2-pole) | 1LA7 1500 rpm (4-pole) | 1000 rpm (6-pole) | 3000 rpm (2-pole) | 1LE1002 1500 rpm (4-pole) |
| 0.09 | - | - | 39 / 50 | - | - |
| 0.12 | - | 42 / 53 | - | - | - |
| 0.18 | 49 / 60 | 42 / 53 | 39 / 50 | - | - |
| 0.25 | 49 / 60 | 44 / 55 | 39 / 50 | - | - |
| 0.37 | 52 / 63 | 44 / 55 | 40 / 51 | - | - |
| 0.55 | 52 / 63 | 47 / 58 | 40 / 51 | - | - |
| 0.75 | 56 / 67 | 47 / 58 | 43 / 55 | - | - |
| 1.1 | 56 / 67 | 48 / 60 | 43 / 55 | - | - |
| 1.5 | 60 / 74 | 48 / 60 | - | - | - |
| 2.2 | 60 / 74 | - | - | - | 60 / 72 |
| 3 | - | - | - | 67 / 79 | 60 / 72 |
| 4 | - | - | - | 69 / 81 | 58 / 70 |
| 5.5 | - | - | - | 68 / 80 | 64 / 76 |
| 7.5 | - | - | - | 68 / 80 | 64 / 76 |
| 11 | - | - | - | 70 / 82 | 65 / 77 |
| 15 | - | - | - | 70 / 82 | 65 / 77 |
| 18.5 | - | - | - | 70 / 82 | - |
| 22 | - | - | - | - | - |
| 30 | - | - | - | - | - |
| 37 | - | - | - | - | - |
| 45 | - | - | - | - | - |
| 55 | - | - | - | - | - |
| 75 | - | - | - | - | - |
| 90 | - | - | - | - | - |
| 110 | - | - | - | - | - |
| 132 | - | - | - | - | - |
| 160 | - | - | - | - | - |
| 185 | - | - | - | - | - |
| 200 | - | - | - | - | - |
| 220 | - | - | - | - | - |
| 250 | - | - | - | - | - |
| 280 | - | - | - | - | - |
| 315 | - | - | - | - | - |

| SIMOTICS General Purpose | | | | | | | | | |
|----------------------------|----------------------|----------------------|----------------------|----------------------|----------------------|----------------------|----------------------|----------------------|----------------------|
| L_{pfa} / L_{WA} (dB(A)) | | | | | | | | | |
| Efficiency IE2 | | | | Cast Iron Series | | | | | |
| 1LE1001 | | | | Efficiency IE1 | | | 1LE0101 | | |
| 1000 rpm (6-pole) | 3000 rpm (2-pole) | 1500 rpm (4-pole) | 1000 rpm (6-pole) | 3000 rpm (2-pole) | 1500 rpm (4-pole) | 1000 rpm (6-pole) | 3000 rpm (2-pole) | 1500 rpm (4-pole) | 1000 rpm (6-pole) |
| - | - | - | - | - | - | - | - | - | - |
| - | - | - | - | - | - | - | - | - | - |
| - | - | - | - | - | - | - | - | - | - |
| - | - | - | - | - | - | - | - | - | - |
| - | - | - | 42 / 53 | - | - | - | - | - | - |
| - | - | 53 / 64 | 42 / 53 | - | 45 / 57 | 44 / 56 | - | 45 / 57 | 44 / 56 |
| - | 60 / 71 | 53 / 64 | 43 / 55 | 53 / 65 | 45 / 57 | 48 / 60 | 53 / 65 | 45 / 57 | 48 / 60 |
| - | 60 / 71 | 56 / 68 | 43 / 55 | 53 / 65 | 48 / 60 | 48 / 60 | 53 / 65 | 47 / 59 | 48 / 60 |
| 59 / 71 | 65 / 77 | 56 / 68 | 59 / 71 | 60 / 72 | 48 / 60 | 54 / 66 | 60 / 72 | 47 / 59 | 52 / 64 |
| 57 / 69 | 65 / 77 | 60 / 72 | 57 / 69 | 60 / 72 | 57 / 69 | 54 / 66 | 60 / 72 | 55 / 67 | 54 / 66 |
| 63 / 75 | 67 / 79 | 60 / 72 | 63 / 75 | 64 / 76 | 57 / 69 | 57 / 69 | 62 / 74 | 55 / 67 | 56 / 69 |
| 63 / 75 | 69 / 81 | 58 / 70 | 63 / 75 | 65 / 77 | 57 / 69 | 57 / 69 | 63 / 75 | 55 / 67 | 56 / 69 |
| 63 / 75 | 68 / 80 | 64 / 76 | 63 / 75 | 68 / 80 | 58 / 71 | 57 / 69 | 66 / 79 | 57 / 70 | 56 / 69 |
| 67 / 79 | 68 / 80 | 64 / 76 | 67 / 79 | 68 / 80 | 58 / 71 | 61 / 73 | 66 / 79 | 57 / 70 | 60 / 73 |
| 67 / 79 | 70 / 82 | 65 / 77 | 67 / 79 | 70 / 83 | 61 / 74 | 61 / 73 | 67 / 80 | 60 / 73 | 60 / 73 |
| - | 70 / 82 | 65 / 77 | - | 70 / 83 | 61 / 74 | 61 / 74 | 67 / 80 | 60 / 73 | 61 / 74 |
| - | 70 / 82 | - | - | 70 / 83 | 63 / 76 | 65 / 78 | 67 / 80 | 61 / 74 | 65 / 78 |
| - | - | - | - | 72 / 85 | 63 / 76 | 65 / 78 | 69 / 82 | 61 / 74 | 65 / 78 |
| - | - | - | - | 76 / 90 | 65 / 78 | 66 / 80 | 71 / 84 | 63 / 76 | 65 / 79 |
| - | - | - | - | 76 / 90 | 66 / 80 | 66 / 80 | 71 / 84 | 63 / 77 | 65 / 79 |
| - | - | - | - | 76 / 90 | 66 / 79 | 66 / 80 | 74 / 88 | 63 / 77 | 65 / 79 |
| - | - | - | - | 78 / 92 | 67 / 81 | 66 / 80 | 74 / 88 | 64 / 78 | 65 / 79 |
| - | - | - | - | 79 / 93 | 70 / 84 | 70 / 84 | 74 / 88 | 66 / 80 | 66 / 80 |
| - | - | - | - | 79 / 93 | 70 / 84 | 70 / 84 | 76 / 90 | 66 / 80 | 66 / 80 |
| - | - | - | - | 80 / 94 | 76 / 90 | 70 / 84 | 78 / 92 | 69 / 83 | 68 / 82 |
| - | - | - | - | 80 / 94 | 76 / 90 | 70 / 84 | 78 / 92 | 69 / 83 | 68 / 83 |
| - | - | - | - | 80 / 94 | 78 / 92 | 77 / 92 | 81 / 95 | 69 / 83 | 72 / 87 |
| - | - | - | - | 85 / 98 | 78 / 92 | 77 / 92 | 81 / 95 | 74 / 88 | 75 / 90 |
| - | - | - | - | 85 / 98 | 78 / 92 | 77 / 92 | 81 / 95 | 74 / 88 | 75 / 90 |
| - | - | - | - | 86 / 101 | 86 / 101 | 77 / 92 | 86 / 101 | 82 / 97 | 75 / 90 |
| - | - | - | - | 86 / 101 | 86 / 101 | - | 86 / 101 | 82 / 97 | - |
| - | - | - | - | 88 / 103 | 86 / 101 | - | 88 / 103 | 85 / 100 | - |
| - | - | - | - | 88 / 103 | 86 / 101 | - | 88 / 103 | 85 / 100 | - |

In order to define the motor noise level, the A-weighted sound pressure level (L_A) is measured at several points on the measuring plane (1 m away from the motor surface). The measurement is carried out in a room with low reflection. As a result of noise reflection, the level can be increased up to 3 dB(A) depending on the acoustic properties of the surroundings.

The A sound power level is normally used when engineering projects and when it is necessary to determine the noise radiated from a group of motors whose envelope dimensions differ significantly.

Bearing

The bearings are especially important in order that the motor runs perfectly. A good selection of bearing will guarantee long lubrication intervals, low noise, low-vibration operation and longer lifetime as well.

There are many types of bearing: diverse ball and cylinder bearings, taper and specialized bearings. Siemens has selected an applicable range of single and double shielded bearings. Z for when regreasing is needed and ZZ when no-regreasing is wished for.

A selection of C62 for speed and size and C63 for load carrying capacity associated with belt loads.

Sealed-for-life bearings are avoided as they bring inherent disadvantages in operation temperatures and limit operational speeds.

Special bearings are avoided due to their disadvantages outside of their specific application.

TIP



Factors that reduce the lifetime of a bearing:

- Operating a motor beyond the rated speed increases the motor vibration and results in an additional radial and axial force on the bearing.
- Increased motor vibration due to the environment or other equipment results in an higher radial and axial force.

The bearing lifetime of motors with horizontal type of construction is at least 40,000 hours if there is no additional axial loading at the coupling output and at least 20,000 hours with the maximum admissible loads.

This assumes that the motor is operated at 50 Hz.

A bearing is only as good as its lubrication. Siemens designed a special lithium complex grease – Unirex N3. It gives a super thermal stability for optimized bearing life. The grease gives a great temperature range from -30 °C to 130 °C – with an intermittent temperature reserve to 165 °C.

| Frame size | Number of poles | Grease lifetime up to CT 40 °C ¹⁾ |
|---|-----------------|--|
| Grease for permanent lubrication bearing | | |
| 80 ... 250 | 2, 4, 6 | 20000 or 40000 (h) ²⁾ |
| Grease for regreasable bearing | | |
| 100 ... 160 | 2, 4, 6 | 8000 (h) |
| 180 ... 250 | 2 | 4000 (h) |
| 180 ... 250 | 4, 6 | 8000 (h) |
| 280 ... 315 | 2 | 3000 (h) |
| 280 ... 315 | 4, 6 | 5000 (h) |
| 355 | 2 | 2000 (h) |
| 355 | 4, 6 | 4000 (h) |

¹⁾ If the coolant temperature is increased by 10 K, the grease lifetime and regreasing interval are halved.

²⁾ 40,000 h apply to horizontally installed motors with coupling output without additional axial loads.

Cantilever force

This force acts transversely at the centerline of the motor shaft extension. The cantilever force is calculated from the circumferential force multiplied by the pre-tension factor, which is dependent on the mechanical transmission characteristics of the particular belt.

The permissible cantilever forces for the individual motor frame sizes and speeds are specified in Catalog D 81.1. For motors with deep-groove ball bearings, the permissible cantilever force can be increased by replacing the bearings at the drive end with cylindrical roller bearings.

In order to calculate the admissible cantilever forces for a radial load, the line of force (i.e. the centerline of the pulley) of the cantilever force F_Q (N) must lie within the free shaft extension (dimension x).

Dimension x [mm] is the distance between the point of application of force F_Q and the shaft shoulder.

Dimension x_{max} corresponds to the length of the shaft extension. Total cantilever force is calculated using the following equation.

$$F_Q = c \cdot F_U$$

The pre-tension factor c is a value gained from experience from the belt manufacturer. The following approximate value can be assumed.

- For normal flat leather belts with an idler pulley, $c = 2$.
- For v-belts, $c = 2$ to 2.5.
- For special synthetic belts (depending on the type and load), $c = 2$ to 2.5.

The circumferential force F_U (N) is calculated using the following equation.

$$F_U = 2 \cdot 10^7 \frac{P}{n \times D}$$

F_U = circumferential force in N

P = rated motor power (transmitted power) in kW

n = rated motor speed

D = pulleys in mm.



Belt drive

A belt drive is used to connect two parallel shafts, the motor shaft with the shaft of the driven machine, whereby the speed can be simultaneously changed corresponding to the ratio between the two belt pulley diameters.

The belt must be pre-tensioned so that it can transmit the circumferential force through friction. The pre-tension factor indicates how much higher the actual tension load (cantilever force) is than the circumferential force (peripheral force).

Today, flat belts are almost always manufactured out of plastic with an adhesive coating (e.g. chrome leather).

Pre-tension factor, approx. 2 to 2.5.

The pre-tension factor for V-belts is approx. 1.5 to 2.5.

The belt must be able to transmit the power at the defined circumferential velocity. This defines the belt thickness and width. The belt supplier specifies the pre-tension factor. The recommended circumferential velocity is approx. 35 m/s for flat belts and approx. 25 m/s for V-belts. Steel belt pulleys must be used for circumferential velocities greater than 26 m/s due to the centrifugal force which occurs.

The actual cantilever force (belt tension) must be compared with the cantilever force permissible for the motor to select the correct motor and bearing sizes.

Bearing – Bearing types

Standard bearing assignment

| SIMOTICS Gen | | | | | | | | | |
|--------------|-----------------|-----------------|-------------------------------------|-----------------------------------|------------|-------------------------------------|-----------------------------------|------------|--|
| Frame size | Number of poles | Aluminum Series | | | | | | | |
| | | Efficiency IE1 | | | | | | | |
| | | 1LA7 | 1LE1002 | | | | | | |
| | | Drive end | Non-drive end (Horizontal mounting) | Non-drive end (Vertical mounting) | Drive end | Non-drive end (Horizontal mounting) | Non-drive end (Vertical mounting) | Drive end | |
| 63 | 2 | 6201 2Z C3 | 6201 2Z C3 | 6201 2Z C3 | - | - | - | - | |
| | 4 | 6201 2Z C3 | 6201 2Z C3 | 6201 2Z C3 | - | - | - | - | |
| | 6 | 6201 2Z C3 | 6201 2Z C3 | 6201 2Z C3 | - | - | - | - | |
| 71 | 2 | 6202 2Z C3 | 6202 2Z C3 | 6202 2Z C3 | - | - | - | - | |
| | 4 | 6202 2Z C3 | 6202 2Z C3 | 6202 2Z C3 | - | - | - | - | |
| | 6 | 6202 2Z C3 | 6202 2Z C3 | 6202 2Z C3 | - | - | - | - | |
| 80 | 2 | 6004 2Z C3 | 6004 2Z C3 | 6004 2Z C3 | - | - | - | 6004 2Z C3 | |
| | 4 | 6004 2Z C3 | 6004 2Z C3 | 6004 2Z C3 | - | - | - | 6004 2Z C3 | |
| | 6 | 6004 2Z C3 | 6004 2Z C3 | 6004 2Z C3 | - | - | - | 6004 2Z C3 | |
| 90 | 2 | 6205 2Z C3 | 6004 2Z C3 | 6004 2Z C3 | - | - | - | 6205 2Z C3 | |
| | 4 | 6205 2Z C3 | 6004 2Z C3 | 6004 2Z C3 | - | - | - | 6205 2Z C3 | |
| | 6 | 6205 2Z C3 | 6004 2Z C3 | 6004 2Z C3 | - | - | - | 6205 2Z C3 | |
| 100 | 2 | - | - | - | 6206 2Z C3 | 6206 2Z C3 | 6206 2Z C3 | 6206 2Z C3 | |
| | 4 | - | - | - | 6206 2Z C3 | 6206 2Z C3 | 6206 2Z C3 | 6206 2Z C3 | |
| | 6 | - | - | - | 6206 2Z C3 | 6206 2Z C3 | 6206 2Z C3 | 6206 2Z C3 | |
| 112 | 2 | - | - | - | 6206 2Z C3 | 6206 2Z C3 | 6206 2Z C3 | 6206 2Z C3 | |
| | 4 | - | - | - | 6206 2Z C3 | 6206 2Z C3 | 6206 2Z C3 | 6206 2Z C3 | |
| | 6 | - | - | - | 6206 2Z C3 | 6206 2Z C3 | 6206 2Z C3 | 6206 2Z C3 | |
| 132 | 2 | - | - | - | 6208 2Z C3 | 6208 2Z C3 | 6208 2Z C3 | 6208 2Z C3 | |
| | 4 | - | - | - | 6208 2Z C3 | 6208 2Z C3 | 6208 2Z C3 | 6208 2Z C3 | |
| | 6 | - | - | - | 6208 2Z C3 | 6208 2Z C3 | 6208 2Z C3 | 6208 2Z C3 | |
| 160 | 2 | - | - | - | 6209 2Z C3 | 6209 2Z C3 | 6209 2Z C3 | 6209 2Z C3 | |
| | 4 | - | - | - | 6209 2Z C3 | 6209 2Z C3 | 6209 2Z C3 | 6209 2Z C3 | |
| | 6 | - | - | - | 6209 2Z C3 | 6209 2Z C3 | 6209 2Z C3 | 6209 2Z C3 | |
| 180 | 2 | - | - | - | - | - | - | - | |
| | 4 | - | - | - | - | - | - | - | |
| | 6 | - | - | - | - | - | - | - | |
| 200 | 2 | - | - | - | - | - | - | - | |
| | 4 | - | - | - | - | - | - | - | |
| | 6 | - | - | - | - | - | - | - | |
| 225 | 2 | - | - | - | - | - | - | - | |
| | 4 | - | - | - | - | - | - | - | |
| | 6 | - | - | - | - | - | - | - | |
| 250 | 2 | - | - | - | - | - | - | - | |
| | 4 | - | - | - | - | - | - | - | |
| | 6 | - | - | - | - | - | - | - | |
| 280 | 2 | - | - | - | - | - | - | - | |
| | 4 | - | - | - | - | - | - | - | |
| | 6 | - | - | - | - | - | - | - | |
| 315 | 2 | - | - | - | - | - | - | - | |
| | 4 | - | - | - | - | - | - | - | |
| | 6 | - | - | - | - | - | - | - | |
| 355 | 2 | - | - | - | - | - | - | - | |
| | 4 | - | - | - | - | - | - | - | |
| | 6 | - | - | - | - | - | - | - | |

| General Purpose | | | | | | | |
|---|---|---------------------------|---|---|---------------------------|---|---|
| | | Cast Iron Series | | | | | |
| Efficiency IE2 1LE1001 | | Efficiency IE1 1LE0102 | | | Efficiency IE2 1LE0101 | | |
| Non-drive end (Horizontal mounting) | Non-drive end (Vertical mounting) | Drive end | Non-drive end (Horizontal mounting) | Non-drive end (Vertical mounting) | Drive end | Non-drive end (Horizontal mounting) | Non-drive end (Vertical mounting) |
| - | - | - | - | - | - | - | - |
| - | - | - | - | - | - | - | - |
| - | - | - | - | - | - | - | - |
| - | - | - | - | - | - | - | - |
| - | - | - | - | - | - | - | - |
| - | - | - | - | - | - | - | - |
| 6004 2Z C3 | 6004 2Z C3 | 6204 2Z C3 | 6204 2Z C3 | 6204 2Z C3 | 6204 2Z C3 | 6204 2Z C3 | 6204 2Z C3 |
| 6004 2Z C3 | 6004 2Z C3 | 6204 2Z C3 | 6204 2Z C3 | 6204 2Z C3 | 6204 2Z C3 | 6204 2Z C3 | 6204 2Z C3 |
| 6004 2Z C3 | 6004 2Z C3 | 6204 2Z C3 | 6204 2Z C3 | 6204 2Z C3 | 6204 2Z C3 | 6204 2Z C3 | 6204 2Z C3 |
| 6004 2Z C3 | 6004 2Z C3 | 6205 2Z C3 | 6205 2Z C3 | 6205 2Z C3 | 6205 2Z C3 | 6205 2Z C3 | 6205 2Z C3 |
| 6004 2Z C3 | 6004 2Z C3 | 6205 2Z C3 | 6205 2Z C3 | 6205 2Z C3 | 6205 2Z C3 | 6205 2Z C3 | 6205 2Z C3 |
| 6004 2Z C3 | 6004 2Z C3 | 6205 2Z C3 | 6205 2Z C3 | 6205 2Z C3 | 6205 2Z C3 | 6205 2Z C3 | 6205 2Z C3 |
| 6004 2Z C3 | 6004 2Z C3 | 6205 2Z C3 | 6205 2Z C3 | 6205 2Z C3 | 6205 2Z C3 | 6205 2Z C3 | 6205 2Z C3 |
| 6206 2Z C3 | 6206 2Z C3 | 6206 2Z C3 | 6206 2Z C3 | 6206 2Z C3 | 6206 2Z C3 | 6206 2Z C3 | 6206 2Z C3 |
| 6206 2Z C3 | 6206 2Z C3 | 6206 2Z C3 | 6206 2Z C3 | 6206 2Z C3 | 6206 2Z C3 | 6206 2Z C3 | 6206 2Z C3 |
| 6206 2Z C3 | 6206 2Z C3 | 6206 2Z C3 | 6206 2Z C3 | 6206 2Z C3 | 6206 2Z C3 | 6206 2Z C3 | 6206 2Z C3 |
| 6206 2Z C3 | 6206 2Z C3 | 6206 2Z C3 | 6206 2Z C3 | 6206 2Z C3 | 6206 2Z C3 | 6206 2Z C3 | 6206 2Z C3 |
| 6206 2Z C3 | 6206 2Z C3 | 6206 2Z C3 | 6206 2Z C3 | 6206 2Z C3 | 6206 2Z C3 | 6206 2Z C3 | 6206 2Z C3 |
| 6206 2Z C3 | 6206 2Z C3 | 6206 2Z C3 | 6206 2Z C3 | 6206 2Z C3 | 6306 2Z C3 | 6206 2Z C3 | 6206 2Z C3 |
| 6206 2Z C3 | 6206 2Z C3 | 6206 2Z C3 | 6206 2Z C3 | 6206 2Z C3 | 6306 2Z C3 | 6206 2Z C3 | 6206 2Z C3 |
| 6208 2Z C3 | 6208 2Z C3 | 6208 2Z C3 | 6208 2Z C3 | 6208 2Z C3 | 6208 2Z C3 | 6208 2Z C3 | 6208 2Z C3 |
| 6208 2Z C3 | 6208 2Z C3 | 6208 2Z C3 | 6208 2Z C3 | 6208 2Z C3 | 6308 2Z C3 | 6208 2Z C3 | 6208 2Z C3 |
| 6208 2Z C3 | 6208 2Z C3 | 6208 2Z C3 | 6208 2Z C3 | 6208 2Z C3 | 6308 2Z C3 | 6208 2Z C3 | 6208 2Z C3 |
| 6209 2Z C3 | 6209 2Z C3 | 6209 2Z C3 | 6209 2Z C3 | 6209 2Z C3 | 6209 2Z C3 | 6209 2Z C3 | 6209 2Z C3 |
| 6209 2Z C3 | 6209 2Z C3 | 6209 2Z C3 | 6209 2Z C3 | 6209 2Z C3 | 6309 2Z C3 | 6209 2Z C3 | 6209 2Z C3 |
| 6209 2Z C3 | 6209 2Z C3 | 6209 2Z C3 | 6209 2Z C3 | 6209 2Z C3 | 6309 2Z C3 | 6209 2Z C3 | 6209 2Z C3 |
| - | - | 6210 Z C3 | 6210 Z C3 | 6210 Z C3 | 6210 Z C3 | 6210 Z C3 | 6210 Z C3 |
| - | - | 6210 Z C3 | 6210 Z C3 | 6210 Z C3 | 6310 Z C3 | 6210 Z C3 | 6210 Z C3 |
| - | - | 6210 Z C3 | 6210 Z C3 | 6210 Z C3 | 6310 Z C3 | 6210 Z C3 | 6210 Z C3 |
| - | - | 6212 Z C3 | 6212 Z C3 | 6212 Z C3 | 6212 Z C3 | 6212 Z C3 | 6212 Z C3 |
| - | - | 6212 Z C3 | 6212 Z C3 | 6212 Z C3 | 6312 Z C3 | 6212 Z C3 | 6212 Z C3 |
| - | - | 6212 Z C3 | 6212 Z C3 | 6212 Z C3 | 6312 Z C3 | 6212 Z C3 | 6212 Z C3 |
| - | - | 6213 Z C3 | 6213 Z C3 | 6213 Z C3 | 6213 Z C3 | 6213 Z C3 | 6213 Z C3 |
| - | - | 6213 Z C3 | 6213 Z C3 | 6213 Z C3 | 6313 Z C3 | 6213 Z C3 | 6213 Z C3 |
| - | - | 6213 Z C3 | 6213 Z C3 | 6213 Z C3 | 6313 Z C3 | 6213 Z C3 | 6213 Z C3 |
| - | - | 6215 C3 | 6215 C3 | 7215 AC | 6215 C3 | 6215 C3 | 7215 AC |
| - | - | 6215 C3 | 6215 C3 | 7215 AC | 6315 C3 | 6215 C3 | 7215 AC |
| - | - | 6215 C3 | 6215 C3 | 7215 AC | 6315 C3 | 6215 C3 | 7215 AC |
| - | - | 6317 C3 | 6317 C3 | 7317 AC | 6317 C3 | 6317 C3 | 7317 AC |
| - | - | 6317 C3 | 6317 C3 | 7317 AC | 6317 C3 | 6317 C3 | 7317 AC |
| - | - | 6317 C3 | 6317 C3 | 7317 AC | 6317 C3 | 6317 C3 | 7317 AC |
| - | - | 6319 C3 | 6319 C3 | 7319 AC | 6319 C3 | 6319 C3 | 7319 AC |
| - | - | 6319 C3 | 6319 C3 | 7319 AC | 6319 C3 | 6319 C3 | 7319 AC |
| - | - | 6319 C3 | 6319 C3 | 7319 AC | 6319 C3 | 6319 C3 | 7319 AC |
| - | - | 6319 C3 | 6319 C3 | 7319 AC | 6319 C3 | 6319 C3 | 7319 AC |
| - | - | 6322 C3 | 6322 C3 | 7322 AC | 6322 C3 | 6322 C3 | 7322 AC |
| - | - | 6322 C3 | 6322 C3 | 7322 AC | 6322 C3 | 6322 C3 | 7322 AC |

Bearing – Bearing types

Bearing design for increased cantilever forces

| SIMOTICS Gen | | | | | | | | | |
|--------------|-----------------|-------------------------------------|-----------------------------------|-----------|-------------------------------------|-----------------------------------|------------|-----------|--|
| Frame size | Number of poles | Aluminum Series | | | | | | | |
| | | Efficiency IE1 | | | | | | | |
| | | 1LA7 | 1LE1002 | | | | | | |
| | Drive end | Non-drive end (Horizontal mounting) | Non-drive end (Vertical mounting) | Drive end | Non-drive end (Horizontal mounting) | Non-drive end (Vertical mounting) | Drive end | | |
| 63 | 2 | - | - | - | - | - | - | - | |
| | 4 | - | - | - | - | - | - | - | |
| | 6 | - | - | - | - | - | - | - | |
| 71 | 2 | - | - | - | - | - | - | - | |
| | 4 | - | - | - | - | - | - | - | |
| | 6 | - | - | - | - | - | - | - | |
| 80 | 2 | - | - | - | - | - | - | - | |
| | 4 | - | - | - | - | - | - | - | |
| | 6 | - | - | - | - | - | - | - | |
| 90 | 2 | - | - | - | - | - | - | - | |
| | 4 | - | - | - | - | - | - | - | |
| | 6 | - | - | - | - | - | - | - | |
| 100 | 2 | - | - | - | 6306 Z C3 | 6205 2Z C3 | 6205 2Z C3 | 6306 Z C3 | |
| | 4 | - | - | - | 6306 Z C3 | 6205 2Z C3 | 6205 2Z C3 | 6306 Z C3 | |
| | 6 | - | - | - | 6306 Z C3 | 6205 2Z C3 | 6205 2Z C3 | 6306 Z C3 | |
| 112 | 2 | - | - | - | 6306 Z C3 | 6205 2Z C3 | 6205 2Z C3 | 6306 Z C3 | |
| | 4 | - | - | - | 6306 Z C3 | 6205 2Z C3 | 6205 2Z C3 | 6306 Z C3 | |
| | 6 | - | - | - | 6306 Z C3 | 6205 2Z C3 | 6205 2Z C3 | 6306 Z C3 | |
| 132 | 2 | - | - | - | 6308 Z C3 | 6208 2Z C3 | 6208 2Z C3 | 6308 Z C3 | |
| | 4 | - | - | - | 6308 Z C3 | 6208 2Z C3 | 6208 2Z C3 | 6308 Z C3 | |
| | 6 | - | - | - | 6308 Z C3 | 6208 2Z C3 | 6208 2Z C3 | 6308 Z C3 | |
| 160 | 2 | - | - | - | 6309 Z C3 | 6209 2Z C3 | 6209 2Z C3 | 6309 Z C3 | |
| | 4 | - | - | - | 6309 Z C3 | 6209 2Z C3 | 6209 2Z C3 | 6309 Z C3 | |
| | 6 | - | - | - | 6309 Z C3 | 6209 2Z C3 | 6209 2Z C3 | 6309 Z C3 | |
| 180 | 2 | - | - | - | - | - | - | - | |
| | 4 | - | - | - | - | - | - | - | |
| | 6 | - | - | - | - | - | - | - | |
| 200 | 2 | - | - | - | - | - | - | - | |
| | 4 | - | - | - | - | - | - | - | |
| | 6 | - | - | - | - | - | - | - | |
| 225 | 2 | - | - | - | - | - | - | - | |
| | 4 | - | - | - | - | - | - | - | |
| | 6 | - | - | - | - | - | - | - | |
| 250 | 2 | - | - | - | - | - | - | - | |
| | 4 | - | - | - | - | - | - | - | |
| | 6 | - | - | - | - | - | - | - | |
| 280 | 2 | - | - | - | - | - | - | - | |
| | 4 | - | - | - | - | - | - | - | |
| | 6 | - | - | - | - | - | - | - | |
| 315 | 2 | - | - | - | - | - | - | - | |
| | 4 | - | - | - | - | - | - | - | |
| | 6 | - | - | - | - | - | - | - | |
| 355 | 2 | - | - | - | - | - | - | - | |
| | 4 | - | - | - | - | - | - | - | |
| | 6 | - | - | - | - | - | - | - | |



Did you know

When the load pulls sideways on the shaft, it is called a radial load. A heavy radial load is a belt or pulley drive. If in doubt, it is common to use “C63” or strengthened bearings.

| General Purpose | | Cast Iron Series | | | | | |
|---|---|---------------------------|---|---|---------------------------|---|---|
| Efficiency IE2 1LE1001 | | Efficiency IE1 1LE0102 | | | Efficiency IE2 1LE0101 | | |
| Non-drive end (Horizontal mounting) | Non-drive end (Vertical mounting) | Drive end | Non-drive end (Horizontal mounting) | Non-drive end (Vertical mounting) | Drive end | Non-drive end (Horizontal mounting) | Non-drive end (Vertical mounting) |
| - | - | - | - | - | - | - | - |
| - | - | - | - | - | - | - | - |
| - | - | - | - | - | - | - | - |
| - | - | - | - | - | - | - | - |
| - | - | - | - | - | - | - | - |
| - | - | - | - | - | - | - | - |
| - | - | - | - | - | - | - | - |
| - | - | - | - | - | - | - | - |
| - | - | - | - | - | - | - | - |
| - | - | - | - | - | - | - | - |
| 6205 2Z C3 | 6205 2Z C3 | 6306 2Z C3 | 6206 2Z C3 | 6206 2Z C3 | 6306 2Z C3 | 6206 2Z C3 | 6206 2Z C3 |
| 6205 2Z C3 | 6205 2Z C3 | 6306 2Z C3 | 6206 2Z C3 | 6206 2Z C3 | 6306 2Z C3 | 6206 2Z C3 | 6206 2Z C3 |
| 6205 2Z C3 | 6205 2Z C3 | 6306 2Z C3 | 6206 2Z C3 | 6206 2Z C3 | 6306 2Z C3 | 6206 2Z C3 | 6206 2Z C3 |
| 6205 2Z C3 | 6205 2Z C3 | 6306 2Z C3 | 6206 2Z C3 | 6206 2Z C3 | 6306 2Z C3 | 6206 2Z C3 | 6206 2Z C3 |
| 6205 2Z C3 | 6205 2Z C3 | 6306 2Z C3 | 6206 2Z C3 | 6206 2Z C3 | - | - | - |
| 6205 2Z C3 | 6205 2Z C3 | 6306 2Z C3 | 6206 2Z C3 | 6206 2Z C3 | - | - | - |
| 6208 2Z C3 | 6208 2Z C3 | 6308 2Z C3 | 6208 2Z C3 | 6208 2Z C3 | 6308 2Z C3 | 6208 2Z C3 | 6208 2Z C3 |
| 6208 2Z C3 | 6208 2Z C3 | 6308 2Z C3 | 6208 2Z C3 | 6208 2Z C3 | - | - | - |
| 6208 2Z C3 | 6208 2Z C3 | 6308 2Z C3 | 6208 2Z C3 | 6208 2Z C3 | - | - | - |
| 6209 2Z C3 | 6209 2Z C3 | 6309 2Z C3 | 6209 2Z C3 | 6209 2Z C3 | 6309 2Z C3 | 6209 2Z C3 | 6209 2Z C3 |
| 6209 2Z C3 | 6209 2Z C3 | 6309 2Z C3 | 6209 2Z C3 | 6209 2Z C3 | - | - | - |
| 6209 2Z C3 | 6209 2Z C3 | 6309 2Z C3 | 6209 2Z C3 | 6209 2Z C3 | - | - | - |
| - | - | NU210 | 6210 Z C3 | 6210 Z C3 | NU210 | 6210 Z C3 | 6210 Z C3 |
| - | - | NU210 | 6210 Z C3 | 6210 Z C3 | NU210 | 6210 Z C3 | 6210 Z C3 |
| - | - | NU210 | 6210 Z C3 | 6210 Z C3 | NU210 | 6210 Z C3 | 6210 Z C3 |
| - | - | NU212 | 6212 Z C3 | 6212 Z C3 | NU212 | 6212 Z C3 | 6212 Z C3 |
| - | - | NU212 | 6212 Z C3 | 6212 Z C3 | NU212 | 6212 Z C3 | 6212 Z C3 |
| - | - | NU212 | 6212 Z C3 | 6212 Z C3 | NU212 | 6212 Z C3 | 6212 Z C3 |
| - | - | NU213 | 6213 Z C3 | 6213 Z C3 | NU213 | 6213 Z C3 | 6213 Z C3 |
| - | - | NU213 | 6213 Z C3 | 6213 Z C3 | NU213 | 6213 Z C3 | 6213 Z C3 |
| - | - | NU213 | 6213 Z C3 | 6213 Z C3 | NU213 | 6213 Z C3 | 6213 Z C3 |
| - | - | NU215 | 6215 C3 | 7215 AC | NU215 | 6215 C3 | 7215 AC |
| - | - | NU215 | 6215 C3 | 7215 AC | NU215 | 6215 C3 | 7215 AC |
| - | - | NU215 | 6215 C3 | 7215 AC | NU215 | 6215 C3 | 7215 AC |
| - | - | NU317 | 6317 C3 | 7317 AC | NU317 | 6317 C3 | 7317 AC |
| - | - | NU317 | 6317 C3 | 7317 AC | NU317 | 6317 C3 | 7317 AC |
| - | - | NU317 | 6317 C3 | 7317 AC | NU317 | 6317 C3 | 7317 AC |
| - | - | NU319 | 6319 C3 | 7319 AC | NU319 | 6319 C3 | 7319 AC |
| - | - | NU319 | 6319 C3 | 7319 AC | NU319 | 6319 C3 | 7319 AC |
| - | - | NU319 | 6319 C3 | 7319 AC | NU319 | 6319 C3 | 7319 AC |
| - | - | NU319 | 6319 C3 | 7319 AC | NU319 | 6319 C3 | 7319 AC |
| - | - | NU322 | 6322 C3 | 7322 AC | NU322 | 6322 C3 | 7322 AC |
| - | - | NU322 | 6322 C3 | 7322 AC | NU322 | 6322 C3 | 7322 AC |

Bearing – Cantilever forces

Admissible cantilever forces for standard version

| SIMOTICS General Purpose | | | | | | | | | | | |
|--------------------------|-----------------|-----------------|--------------------|----------------|--------------------|----------------|--------------------|------------------|--------------------|----------------|--------------------|
| Frame size | Number of poles | Aluminum Series | | | | | | Cast Iron Series | | | |
| | | Efficiency IE1 | | | | Efficiency IE2 | | Efficiency IE1 | | Efficiency IE2 | |
| | | 1LA7 | | 1LE1002 | | 1LE1001 | | 1LE0102 | | 1LE0101 | |
| | | for x_0 N | for x_{max} N | for x_0 N | for x_{max} N | for x_0 N | for x_{max} N | for x_0 N | for x_{max} N | for x_0 N | for x_{max} N |
| 63 | 2 | 270 | 240 | - | - | - | - | - | - | - | - |
| | 4 | 350 | 305 | - | - | - | - | - | - | - | - |
| | 6 | 415 | 360 | - | - | - | - | - | - | - | - |
| 71 | 2 | 415 | 355 | - | - | - | - | - | - | - | - |
| | 4 | 530 | 450 | - | - | - | - | - | - | - | - |
| | 6 | 630 | 535 | - | - | - | - | - | - | - | - |
| 80 | 2 | 485 | 400 | - | - | 485 | 400 | 620 | 510 | 620 | 510 |
| | 4 | 625 | 515 | - | - | 625 | 515 | 790 | 640 | 790 | 640 |
| | 6 | 735 | 605 | - | - | 735 | 605 | 910 | 740 | 910 | 740 |
| 90 | 2 | 725 | 605 | - | - | 725 | 605 | 700 | 560 | 700 | 560 |
| | 4 | 920 | 775 | - | - | 920 | 775 | 880 | 720 | 880 | 720 |
| | 6 | 1090 | 910 | - | - | 1090 | 910 | 1020 | 820 | 1020 | 820 |
| 100 | 2 | - | - | 1010 | 825 | 1010 | 825 | 980 | 790 | 980 | 790 |
| | 4 | - | - | 1230 | 1010 | 1230 | 1010 | 1230 | 990 | 1230 | 990 |
| | 6 | - | - | 1440 | 1180 | 1440 | 1180 | 1420 | 1140 | 1420 | 1140 |
| 112 | 2 | - | - | 970 | 785 | 970 | 785 | 980 | 790 | 980 | 790 |
| | 4 | - | - | 1235 | 1000 | 1235 | 1000 | 1230 | 990 | 1870 | 1540 |
| | 6 | - | - | 1440 | 1165 | 1440 | 1165 | 1420 | 1140 | 2140 | 1720 |
| 132 | 2 | - | - | 1470 | 1180 | 1470 | 1180 | 1440 | 1120 | 1440 | 1120 |
| | 4 | - | - | 1830 | 1470 | 1830 | 1470 | 1820 | 1420 | 2720 | 2170 |
| | 6 | - | - | 2150 | 1730 | 2150 | 1730 | 2080 | 1630 | 3100 | 2420 |
| 160 | 2 | - | - | 1550 | 1270 | 1550 | 1270 | 1560 | 1240 | 1560 | 1240 |
| | 4 | - | - | 1910 | 1550 | 1910 | 1550 | 1970 | 1570 | 3300 | 2600 |
| | 6 | - | - | 2230 | 1810 | 2230 | 1810 | 2260 | 1800 | 3750 | 2900 |
| 180 | 2 | - | - | - | - | - | - | 1820 | 1470 | 1820 | 1470 |
| | 4 | - | - | - | - | - | - | 2300 | 1900 | 4000 | 3300 |
| | 6 | - | - | - | - | - | - | 2630 | 2150 | 4500 | 3700 |
| 200 | 2 | - | - | - | - | - | - | 2650 | 2230 | 2650 | 2230 |
| | 4 | - | - | - | - | - | - | 3350 | 2800 | 5400 | 4530 |
| | 6 | - | - | - | - | - | - | 3850 | 3230 | 6200 | 5200 |
| 225 | 2 | - | - | - | - | - | - | 3000 | 2540 | 3000 | 2540 |
| | 4 | - | - | - | - | - | - | 3700 | 3000 | 5900 | 4800 |
| | 6 | - | - | - | - | - | - | 4250 | 3470 | 6800 | 5550 |
| 250 | 2 | - | - | - | - | - | - | 3150 | 2620 | 3150 | 2620 |
| | 4 | - | - | - | - | - | - | 3950 | 3280 | 7350 | 6100 |
| | 6 | - | - | - | - | - | - | 4600 | 3820 | 8450 | 7000 |
| 280 | 2 | - | - | - | - | - | - | 6600 | 5550 | 6600 | 5550 |
| | 4 | - | - | - | - | - | - | 8300 | 6950 | 8300 | 6950 |
| | 6 | - | - | - | - | - | - | 9650 | 8120 | 9650 | 8120 |
| 315 | 2 | - | - | - | - | - | - | 7100 | 6200 | 7100 | 6200 |
| | 4 | - | - | - | - | - | - | 8700 | 7250 | 8700 | 7250 |
| | 6 | - | - | - | - | - | - | 10000 | 8500 | 10000 | 8500 |
| 355 | 2 | - | - | - | - | - | - | 6800 | 6000 | 6800 | 6000 |
| | 4 | - | - | - | - | - | - | 11500 | 10000 | 11500 | 10000 |
| | 6 | - | - | - | - | - | - | 13200 | 11600 | 13200 | 11600 |

Bearing design for increased cantilever forces

| SIMOTICS General Purpose | | | | | | | | | | | |
|--------------------------|-----------------|------------------------|--------------------|---------------------------|--------------------|---------------------------|--------------------|---------------------------|--------------------|---------------------------|--------------------|
| Frame size | Number of poles | Aluminum Series | | | | | | Cast Iron Series | | | |
| | | Efficiency IE1 1LA7 | | Efficiency IE1 1LE1002 | | Efficiency IE2 1LE1001 | | Efficiency IE1 1LE0102 | | Efficiency IE2 1LE0101 | |
| | | for x_0 N | for x_{max} N | for x_0 N | for x_{max} N | for x_0 N | for x_{max} N | for x_0 N | for x_{max} N | for x_0 N | for x_{max} N |
| 63 | 2 | - | - | - | - | - | - | - | - | - | - |
| | 4 | - | - | - | - | - | - | - | - | - | - |
| | 6 | - | - | - | - | - | - | - | - | - | - |
| 71 | 2 | - | - | - | - | - | - | - | - | - | - |
| | 4 | - | - | - | - | - | - | - | - | - | - |
| | 6 | - | - | - | - | - | - | - | - | - | - |
| 80 | 2 | - | - | - | - | - | - | - | - | - | - |
| | 4 | - | - | - | - | - | - | - | - | - | - |
| | 6 | - | - | - | - | - | - | - | - | - | - |
| 90 | 2 | - | - | - | - | - | - | - | - | - | - |
| | 4 | - | - | - | - | - | - | - | - | - | - |
| | 6 | - | - | - | - | - | - | - | - | - | - |
| 100 | 2 | - | - | 1585 | 1300 | 1585 | 1300 | 1480 | 1220 | 1480 | 1220 |
| | 4 | - | - | 1960 | 1610 | 1960 | 1610 | 1870 | 1540 | 1870 | 1540 |
| | 6 | - | - | 2270 | 1865 | 2270 | 1865 | 2140 | 1720 | 2140 | 1720 |
| 112 | 2 | - | - | 1545 | 1250 | 1545 | 1250 | 1480 | 1220 | 1480 | 1220 |
| | 4 | - | - | 1960 | 1585 | 1960 | 1585 | 1870 | 1540 | - | - |
| | 6 | - | - | 2270 | 1835 | 2270 | 1835 | 2140 | 1720 | - | - |
| 132 | 2 | - | - | 2285 | 1840 | 2285 | 1840 | 2100 | 1700 | 2100 | 1700 |
| | 4 | - | - | 2860 | 2300 | 2860 | 2300 | 2720 | 2170 | - | - |
| | 6 | - | - | 3320 | 2670 | 3320 | 2670 | 3100 | 2420 | - | - |
| 160 | 2 | - | - | 2800 | 2240 | 2800 | 2240 | 2650 | 2120 | 2650 | 2120 |
| | 4 | - | - | 3450 | 2270 | 3450 | 2270 | 3300 | 2600 | - | - |
| | 6 | - | - | 4000 | 3200 | 4000 | 3200 | 3750 | 2900 | - | - |
| 180 | 2 | - | - | - | - | - | - | 3300 | 2700 | 3300 | 2700 |
| | 4 | - | - | - | - | - | - | 4200 | 3400 | 4200 | 3400 |
| | 6 | - | - | - | - | - | - | 4750 | 3900 | 4750 | 3900 |
| 200 | 2 | - | - | - | - | - | - | 5000 | 4200 | 5000 | 4200 |
| | 4 | - | - | - | - | - | - | 6330 | 5320 | 6330 | 5320 |
| | 6 | - | - | - | - | - | - | 7250 | 6080 | 7250 | 6080 |
| 225 | 2 | - | - | - | - | - | - | 5650 | 4800 | 5650 | 4800 |
| | 4 | - | - | - | - | - | - | 6950 | 5600 | 6950 | 5600 |
| | 6 | - | - | - | - | - | - | 7900 | 6500 | 7900 | 6500 |
| 250 | 2 | - | - | - | - | - | - | 6700 | 5600 | 6700 | 5600 |
| | 4 | - | - | - | - | - | - | 8500 | 7000 | 8500 | 7000 |
| | 6 | - | - | - | - | - | - | 9500 | 7800 | 9500 | 7800 |
| 280 | 2 | - | - | - | - | - | - | 11500 | 9500 | 11500 | 9500 |
| | 4 | - | - | - | - | - | - | 17000 | 14000 | 17000 | 14000 |
| | 6 | - | - | - | - | - | - | 20000 | 17000 | 20000 | 17000 |
| 315 | 2 | - | - | - | - | - | - | 14600 | 12300 | 14600 | 12300 |
| | 4 | - | - | - | - | - | - | 20000 | 16500 | 20000 | 16500 |
| | 6 | - | - | - | - | - | - | 23000 | 19000 | 23000 | 19000 |
| 355 | 2 | - | - | - | - | - | - | 15800 | 14000 | 15800 | 14000 |
| | 4 | - | - | - | - | - | - | 22000 | 19000 | 22000 | 19000 |
| | 6 | - | - | - | - | - | - | 25000 | 22000 | 25000 | 22000 |

Terminal box

TIP

The terminal box is located on the top of the motor housing as standard, and can be rotated by $4 \times 90^\circ$ – on some 1LE1 even 360° – to allow for cable entry from each direction.

All terminal boxes have two cable entries sealed by a screwed plug.



1LA7

| Frame size | Aluminum Series | | | | |
|------------|---------------------|----------------------|---|--------------------------------------|---------------------------------|
| | Efficiency IE1 | | | | |
| | Number of terminals | Contact screw thread | Max. connectable cross-section (mm ²) | Outer cable diameter (sealing range) | Cable entry size (screwed plug) |
| 63 | 6 | M4 | 1.5 | 9 ... 17 | 1xM25x1.5 + 1xM16x1.5 |
| 71 | 6 | M4 | 1.5 | 9 ... 17 | 1xM25x1.5 + 1xM16x1.5 |
| 80 | 6 | M4 | 1.5 | 9 ... 17 | 1xM25x1.5 + 1xM16x1.5 |
| 90 | 6 | M4 | 1.5 | 9 ... 17 | 1xM25x1.5 + 1xM16x1.5 |



1LE10

| Frame size | Aluminum Series | | | | | | | | | |
|------------|---------------------|----------------------|---|--------------------------------------|---------------------------------|---------------------|----------------------|---|--------------------------------------|---------------------------------|
| | Efficiency IE1 | | | | | Efficiency IE2 | | | | |
| | Number of terminals | Contact screw thread | Max. connectable cross-section (mm ²) | Outer cable diameter (sealing range) | Cable entry size (screwed plug) | Number of terminals | Contact screw thread | Max. connectable cross-section (mm ²) | Outer cable diameter (sealing range) | Cable entry size (screwed plug) |
| 80 | – | – | – | – | – | 6 | M3.5 | 1.5 | 9 ... 17 | 1xM25x1.5 + 1xM16x1.5 |
| 90 | – | – | – | – | – | 6 | M3.5 | 1.5 | 9 ... 17 | 1xM25x1.5 + 1xM16x1.5 |
| 100 | 6 | M4 | 4 | 11 ... 21 | 2xM32x1.5 | 6 | M4 | 4 | 11 ... 21 | 2xM32x1.5 |
| 112 | 6 | M4 | 4 | 11 ... 21 | 2xM32x1.5 | 6 | M4 | 4 | 11 ... 21 | 2xM32x1.5 |
| 132 | 6 | M4 | 6 | 11 ... 21 | 2xM32x1.5 | 6 | M4 | 6 | 11 ... 21 | 2xM32x1.5 |
| 160 | 6 | M5 | 16 | 19 ... 28 | 2xM40x1.5 | 6 | M5 | 16 | 19 ... 28 | 2xM40x1.5 |

Motors with an aluminum housing are particularly user friendly. The terminal box introduced for frame sizes 100 to 160 has proven its worth and is consistently implemented throughout the motor series for 2- and 4-pole motors of frame sizes 80 and 90.

The terminal box is only fixed with one screw and can be rotated steplessly by up to 360° . The terminal box is also preconfigured with a terminal board. This makes installation quicker and easier in confined spaces as the motor connection cables can be fed in from any direction.



1LE0

| Frame size | Cast Iron Series | | | | | | | | | |
|---|---------------------|----------------------|--------------------------------------|---------------------------------|---|--------------------------------------|---------------------------------|-----|---------------------|-----------------------|
| | Efficiency IE1 | | | | | Efficiency IE2 | | | | |
| | Number of terminals | Contact screw thread | 1LE0102 | | | 1LE0101 | | | Number of terminals | Contact screw thread |
| Max. connectable cross-section (mm ²) | | | Outer cable diameter (sealing range) | Cable entry size (screwed plug) | Max. connectable cross-section (mm ²) | Outer cable diameter (sealing range) | Cable entry size (screwed plug) | | | |
| 80 | 6 | M4 | 1.5 | 13 ... 18 | M25 x 1.5 + M16 x 1.5 | 6 | M4 | 1.5 | 13 ... 18 | M25 x 1.5 + M16 x 1.5 |
| 90 | 6 | M4 | 1.5 | 13 ... 18 | M25 x 1.5 + M16 x 1.5 | 6 | M4 | 1.5 | 13 ... 18 | M25 x 1.5 + M16 x 1.5 |
| 100 | 6 | M4 | 4 | 18 ... 25 | M32 x 1.5 + M32 x 1.5 | 6 | M4 | 4 | 18 ... 25 | M32 x 1.5 + M32 x 1.5 |
| 112 | 6 | M4 | 4 | 18 ... 25 | M32 x 1.5 + M32 x 1.5 | 6 | M4 | 4 | 18 ... 25 | M32 x 1.5 + M32 x 1.5 |
| 132 | 6 | M4 | 6 | 18 ... 25 | M32 x 1.5 + M32 x 1.5 | 6 | M4 | 6 | 18 ... 25 | M32 x 1.5 + M32 x 1.5 |
| 160 | 6 | M5 | 16 | 22 ... 32 | M40 x 1.5 + M40 x 1.5 | 6 | M5 | 16 | 22 ... 32 | M40 x 1.5 + M40 x 1.5 |
| 180 | 6 | M5 | 16 | 22 ... 32 | M40 x 1.5 + M40 x 1.5 | 6 | M5 | 16 | 22 ... 32 | M40 x 1.5 + M40 x 1.5 |
| 200 | 6 | M6 | 25 | 32 ... 38 | M50 x 1.5 + M50 x 1.5 | 6 | M6 | 25 | 32 ... 38 | M50 x 1.5 + M50 x 1.5 |
| 225 | 6 | M8 | 35 | 32 ... 38 | M50 x 1.5 + M50 x 1.5 | 6 | M8 | 35 | 32 ... 38 | M50 x 1.5 + M50 x 1.5 |
| 250 | 6 | M10 | 120 | 37 ... 44 | M63 x 1.5 + M63 x 1.5 | 6 | M10 | 120 | 37 ... 44 | M63 x 1.5 + M63 x 1.5 |
| 280 | 6 | M10 | 120 | 37 ... 44 | M63 x 1.5 + M63 x 1.5 | 6 | M10 | 120 | 37 ... 44 | M63 x 1.5 + M63 x 1.5 |
| 315 | 6 | M12 | 240 | 37 ... 44 | M63 x 1.5 + M63 x 1.5 | 6 | M12 | 240 | 37 ... 44 | M63 x 1.5 + M63 x 1.5 |
| 355 | 6 | M20 | 240 | 44 ... 57 | M72 x 2 + M72 x 2 | 6 | M20 | 240 | 44 ... 57 | M72 x 2 + M72 x 2 |

Dimension drawings

IM B3

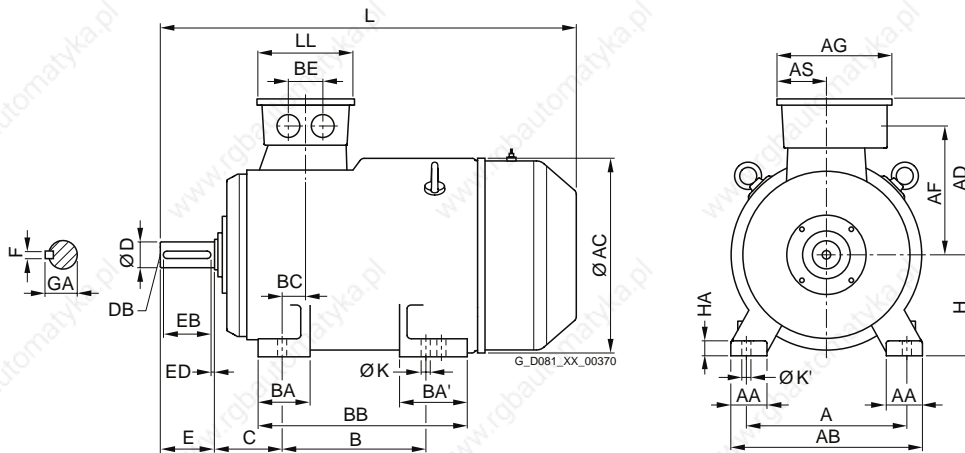

IM B35

For flange dimensions, see Page 58 (Z = the number of retaining holes)

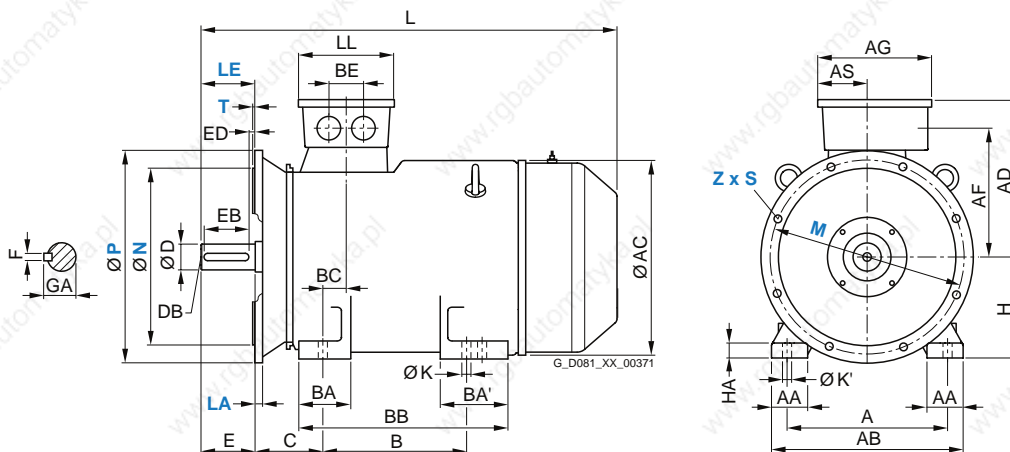

IM B5 and IM V1

For flange dimensions, see Page 58 (Z = the number of retaining holes)

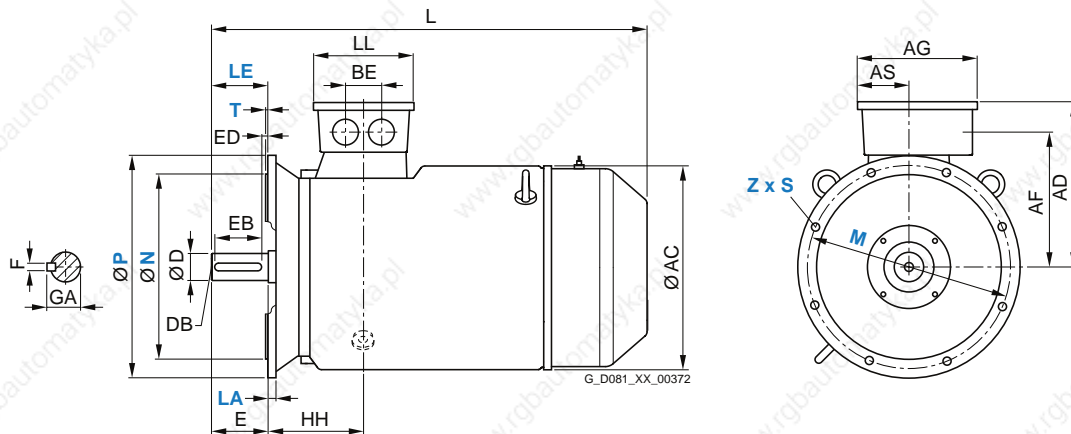

IM B14

For flange dimensions, see Page 58 (Z = the number of retaining holes)

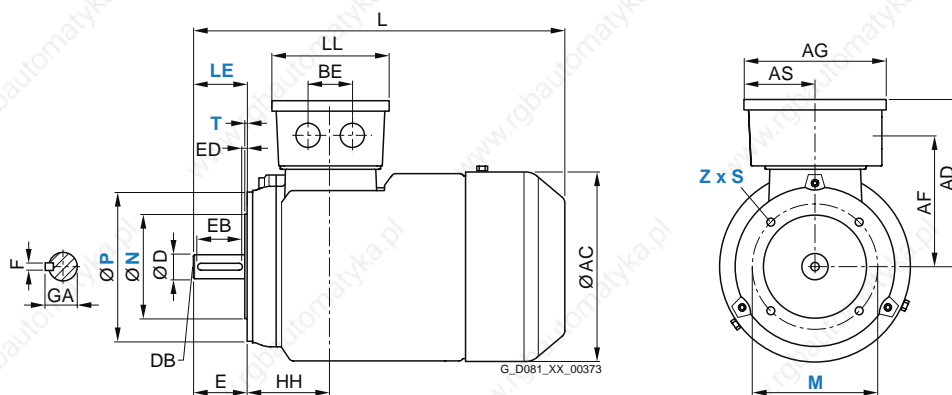

Aluminum series – 1LA7

| For motor | | | Dimension designation acc. to IEC | | | | | | | | | | | | | | | | | | | | |
|--------------|--------------------|-----------------|-----------------------------------|------|-----|------------------|------------------|-----|------------------|-----|------------------|------|-----|----|-----|-----|----|------------------|-------------------|----|-------------------|-----|----|
| Frame size | Type | Number of poles | A | AA | AB | AC ¹⁾ | AD ²⁾ | AD' | AF ²⁾ | AF' | AG ²⁾ | AS | B* | BA | BA' | BB | BC | BE ²⁾ | BE' ²⁾ | C | CA* | H | HA |
| 63 M | 1LA7060 1LA7063 | 2, 4, 6 | 100 | 27 | 120 | 124 | 101 | 101 | 78 | 78 | 75 | 37.5 | 80 | 28 | – | 96 | 30 | 32 | 18 | 40 | 66 | 63 | 7 |
| 71 M | 1LA7070 1LA7073 | 2, 4, 6 | 112 | 27 | 132 | 145 | 111 | 111 | 88 | 88 | 75 | 37.5 | 90 | 27 | – | 106 | 18 | 32 | 18 | 45 | 83 | 71 | 7 |
| 80 M | 1LA7080 1LA7083 | 2, 4, 6 | 125 | 30.5 | 150 | 163 | 120 | 120 | 97 | 97 | 75 | 37.5 | 100 | 32 | – | 118 | 14 | 32 | 18 | 50 | 94 | 80 | 8 |
| 90 S | 1LA7090 | 2, 4, 6 | 140 | 30.5 | 165 | 180 | 128 | 128 | 105 | 105 | 75 | 37.5 | 100 | 33 | 54 | 143 | 23 | 32 | 18 | 56 | 143 | 90 | 10 |
| 90 L | 1LA7096 | 2, 4, 6 | | | | | | | | | | | 125 | | | | | | | | 118 | | |
| 100 L | 1LA7106 1LA7107 | 2, 4, 6 2 | 160 | 42 | 196 | 203 | 135 | 163 | 78 | 123 | 120 | 60 | 140 | 47 | – | 176 | 39 | 42 | 21 | 63 | 125 | 100 | 12 |
| | | | | | | | | | | | | | | | | | | | | | 195 ³⁾ | | |

* This dimension is assigned in DIN EN 50347 to the frame size listed.

¹⁾ Measured across the bolt heads.

²⁾ The values increase if the terminal box is rotated or if a brake is mounted.

Further information is provided by the dimension sheet generator in the DT Configurator.

³⁾ Only for 1LA7107-4PM.

Aluminum series – 1LE10

| For motor | | Dimension designation acc. to IEC | | | | | | | | | | | | | | | | | | | | | |
|--------------|-----------------|-----------------------------------|------|-----|-----|-------|-------|-------|-------|-----|------|-----|------|------------------|-------------------|------|----|------------------|-----------------|---------------------|-----|----|-----------------|
| Frame size | Number of poles | A | AA | AB | AC | AD | AD' | AF | AF' | AG | AS | B* | BA | BA' | BB | BC | BE | BE' | C ¹⁾ | CA* | H | HA | Y ¹⁾ |
| 80 M | 2, 4, 6 | 125 | 30.5 | 150 | 159 | 121 | – | 96.5 | – | 93 | 43 | 100 | 32 | – | 118 | 23 | – | 18 ²⁾ | 50 | – | 80 | 8 | 41 |
| 90 S | 2, 4, 6 | 140 | 30.5 | 165 | 178 | 126 | – | 101.5 | – | 93 | 43 | 100 | 33 | – | 143 | 22.5 | – | 18 ²⁾ | 56 | – | 90 | 10 | 47 |
| 90 L | 2, 4, 6 | 140 | 30.5 | 165 | 178 | 126 | – | 101.5 | – | 93 | 43 | 125 | 33 | – | 143 | 22.5 | – | 18 ²⁾ | 56 | – | 90 | 10 | 47 |
| 100 L | 2, 4, 6 | 160 | 42 | 196 | 198 | 166 | 166 | 125.5 | 125.5 | 135 | 63.5 | 140 | 37.5 | – | 176 | 33.5 | 50 | 25 | 63 | 141 | 100 | 12 | 45 |
| 112 M | 2, 4, 6 | 190 | 46 | 226 | 222 | 177 | 177 | 136.5 | 136.5 | 135 | 63.5 | 140 | 35.4 | – | 176 | 26 | 50 | 25 | 70 | 129.7 | 112 | 12 | 52 |
| 132 S | 2, 4, 6 | 216 | 53 | 256 | 262 | 202 | 202 | 159.5 | 159.5 | 155 | 70.5 | 140 | 38 | 76 ³⁾ | 218 ⁴⁾ | 26.5 | 48 | 24 | 89 | 128.5 ⁵⁾ | 132 | 15 | 69 |
| 132 M | 2, 4, 6 | 216 | 53 | 256 | 262 | 202 | 202 | 159.5 | 159.5 | 155 | 70.5 | 178 | 38 | 76 | 218 | 26.5 | 48 | 24 | 89 | 128.5 ⁵⁾ | 132 | 15 | 69 |
| 160 M | 2, 4, 6 | 254 | 60 | 300 | 314 | 236.5 | 236.5 | 190 | 190 | 175 | 77.5 | 210 | 44 | 89 ⁶⁾ | 300 ⁷⁾ | 47 | 57 | 28.5 | 108 | 148 ⁸⁾ | 160 | 18 | 85 |
| 160 L | 2, 4, 6 | 254 | 60 | 300 | 314 | 236.5 | 236.5 | 190 | 190 | 175 | 77.5 | 254 | 44 | 89 | 300 | 47 | 57 | 28.5 | 108 | 148 ⁸⁾ | 160 | 18 | 85 |

* This dimension is assigned in DIN EN 50347 to the frame size listed.

¹⁾ Additional information – not a standard dimension according to DIN EN 50347.

²⁾ Connecting hole for terminal box is on the side at the rear of the terminal box.

³⁾ With screwed-on feet, dimension BA' is 38 mm.

⁴⁾ With screwed-on feet, dimension BB is 180 mm.

⁵⁾ With screwed-on feet, dimension CA is 166.5 mm.

⁶⁾ With screwed-on feet, dimension BA' is 44 mm.

⁷⁾ With screwed-on feet, dimension BB is 256 mm.

⁸⁾ With screwed-on feet, dimension CA is 192 mm.

⁹⁾ The length is specified as far as the tip of the fan cover.

Aluminum series – 1LA7

| For motor | | | Dimension designation acc. to IEC | | | | | | | DE shaft extension | | | | | | |
|--------------|---------|-----------------|-----------------------------------|-----|------|---------------------|-------------------|-----|---------------------|--------------------|-----|----|----|-----|---|------|
| Frame size | Type | Number of poles | HH | K | K' | L | LC | LL | LM | D | DB | E | EB | ED | F | GA |
| 63 M | 1LA7060 | 2, 4, 6 | 69.5 | 7 | 10 | 202.5 ¹⁾ | 232 ¹⁾ | 75 | 231.5 ¹⁾ | 11 | M4 | 23 | 16 | 3.5 | 4 | 12.5 |
| | 1LA7063 | | | | | | | | | | | | | | | |
| 71 M | 1LA7070 | 2, 4, 6 | 63.5 | 7 | 10 | 240 | 278 | 75 | 268 | 14 | M5 | 30 | 22 | 4 | 5 | 16 |
| | 1LA7073 | | | | | | | | | | | | | | | |
| 80 M | 1LA7080 | 2, 4, 6 | 63.5 | 9.5 | 13.5 | 273.5 | 324 | 75 | 299.5 | 19 | M6 | 40 | 32 | 4 | 6 | 21.5 |
| | 1LA7083 | | | | | | | | | | | | | | | |
| 90 S | 1LA7090 | 2, 4, 6 | 79 | 10 | 14 | 331 | 389 | 75 | 382.5 | 24 | M8 | 50 | 40 | 5 | 8 | 27 |
| 90 L | 1LA7096 | 2, 4, 6 | | | | | | | | | | | | | | |
| 100 L | 1LA7106 | 2, 4, 6 | 102 | 12 | 16 | 372 | 438 | 120 | 423.5 | 28 | M10 | 60 | 50 | 5 | 8 | 31 |
| | 1LA7107 | | | | | | | | | | | | | | | |

Aluminum series – 1LE10

| For motor | | Dimension designation acc. to IEC | | | | | | | DE shaft extension | | | | | | | | |
|--------------|-----------------|-----------------------------------|-----|------|---------------------|-----|----|-------|--------------------|-------|----|-----|-----|----|----|----|------|
| Frame size | Number of poles | HH | K | K' | L | L1 | D1 | LC | LL | LM | D | DB | E | EB | ED | F | GA |
| 80 M | 2, 4, 6 | 73 | 9.5 | 13.5 | 292 | – | – | – | 79 | – | 19 | M6 | 40 | 32 | 4 | 6 | 21.5 |
| 90 S | 2, 4, 6 | 78.5 | 10 | 14 | 347 | – | – | – | 79 | – | 24 | M8 | 50 | 40 | 5 | 8 | 27 |
| 90 L | 2, 4, 6 | 78.5 | 10 | 14 | 347 | – | – | – | 79 | – | 24 | M8 | 50 | 40 | 5 | 8 | 27 |
| 100 L | 2, 4, 6 | 96.5 | 12 | 16 | 395.5 ⁹⁾ | 7 | 32 | 454 | 112 | 428.5 | 28 | M10 | 60 | 50 | 5 | 8 | 31 |
| 112 M | 2, 4, 6 | 96 | 12 | 16 | 389 ⁹⁾ | 7 | 32 | 450 | 112 | 422 | 28 | M10 | 60 | 50 | 5 | 8 | 31 |
| 132 S | 2, 4, 6 | 115.5 | 12 | 16 | 465 ⁹⁾ | 8.5 | 39 | 535.5 | 130 | 516.5 | 38 | M12 | 80 | 70 | 5 | 10 | 41 |
| 132 M | 2, 4, 6 | 115.5 | 12 | 16 | 465 ⁹⁾ | 8.5 | 39 | 535.5 | 130 | 516.5 | 38 | M12 | 80 | 70 | 5 | 10 | 41 |
| 160 M | 2, 4, 6 | 155 | 15 | 19 | 604 ⁹⁾ | 10 | 45 | 730 | 145 | 654 | 42 | M16 | 110 | 90 | 10 | 12 | 45 |
| 160 L | 2, 4, 6 | 155 | 15 | 19 | 604 ⁹⁾ | 10 | 45 | 730 | 145 | 654 | 42 | M16 | 110 | 90 | 10 | 12 | 45 |

Cast Iron series – 1LE0

| For motor | | Dimension designation acc. to IEC | | | | | | | | | | | | | | | | | |
|------------|--------------------|-----------------------------------|-----|-----|-----|------------------|--------|--------|-----|-------|-----------------|--------|-----|------|-----|---------|-------|-----|----|
| Frame size | Motor type 1LE0- | Number of poles | A | AA | AB | AC ¹⁾ | AD/AD' | AF/AF' | AG | AS | B ²⁾ | BA/BA' | BB | BC | BE | C | CA* | H | HA |
| 80 M | OD.2 | 2 | 125 | 36 | 160 | 157 | 142 | 110.5 | 161 | 65.5 | 100 | 44 | 135 | 26 | 42 | 50 | 103 | 80 | 10 |
| | OD.2 | 4, 6 | 125 | 36 | 160 | 157 | 142 | 110.5 | 161 | 65.5 | 100 | 44 | 135 | 26 | 42 | 50 | 103 | 80 | 10 |
| | OD.3 | 2, 4, 6 | 125 | 36 | 160 | 157 | 142 | 110.5 | 161 | 65.5 | 100 | 44 | 135 | 26 | 42 | 50 | 103 | 80 | 10 |
| 90 S | OE.0 | 2, 4, 6 | 140 | 46 | 175 | 175 | 152 | 120.5 | 161 | 65.5 | 100 | 46 | 140 | 20 | 42 | 56 | 115 | 90 | 10 |
| 90 L | OE.4 | | 140 | 46 | 175 | 175 | 152 | 120.5 | 161 | 65.5 | 125 | 46 | 165 | 20 | 42 | 56 | 115 | 90 | 10 |
| 100 L | 1A.4 | 2, 4, 6 | 160 | 45 | 200 | 196 | 177 | 140 | 175 | 70 | 140 | 45 | 176 | 30.5 | 54 | 63/78 | 133 | 100 | 12 |
| | 1A.5 | 4 | 160 | 45 | 200 | 196 | 177 | 140 | 175 | 70 | 140 | 45 | 176 | 30.5 | 54 | 63/78 | 133 | 100 | 12 |
| 112 M | 1B.2 | 2, 4, 6 | 190 | 45 | 226 | 221 | 188.5 | 152 | 175 | 70 | 140 | 50 | 180 | 22 | 54 | 70 | 129.5 | 112 | 12 |
| 132 S | 1C.0 | 2, 4, 6 | 216 | 50 | 256 | 259 | 191.5 | 175 | 175 | 70 | 140 | 64 | 186 | 32.5 | 54 | 89/104 | 178 | 132 | 15 |
| | 1C.1 | 2 | 216 | 50 | 256 | 259 | 191.5 | 175 | 175 | 70 | 140 | 64 | 186 | 32.5 | 54 | 89/104 | 178 | 132 | 15 |
| 132 M | 1C.2 | 4, 6 | 216 | 50 | 256 | 259 | 191.5 | 175 | 175 | 70 | 178 | 64 | 224 | 32.5 | 54 | 89/111 | 185 | 132 | 15 |
| | 1C.3 | 6 | 216 | 50 | 256 | 259 | 191.5 | 175 | 175 | 70 | 178 | 64 | 224 | 32.5 | 54 | 89/111 | 185 | 132 | 15 |
| 160 M | 1D.2 | 2, 4, 6 | 254 | 60 | 314 | 312 | 255 | 206 | 231 | 94 | 210 | 70 | 258 | 51 | 68 | 108/112 | 194 | 160 | 20 |
| | 1D.3 | 2 | 254 | 60 | 314 | 312 | 255 | 206 | 231 | 94 | 210 | 70 | 258 | 51 | 68 | 108/112 | 194 | 160 | 20 |
| 160 L | 1D.4 | 2, 4, 6 | 254 | 60 | 314 | 312 | 255 | 206 | 231 | 94 | 254 | 70 | 302 | 51 | 68 | 108/128 | 210 | 160 | 20 |
| 180M | 1E.2 | 2, 4 | 279 | 65 | 339 | 356 | 270 | 221 | 231 | 94 | 241 | 80 | 301 | 37 | 68 | 121/115 | 219 | 180 | 20 |
| 180L | 1E.4 | 4, 6 | 279 | 65 | 339 | 356 | 270 | 221 | 231 | 94 | 279 | 80 | 339 | 37 | 68 | 121/112 | 216 | 180 | 20 |
| 200L | 2A.4 | 2, 6 | 318 | 70 | 378 | 397 | 300 | 247.5 | 288 | 107.5 | 305 | 80 | 369 | 69 | 85 | 133/123 | 234 | 200 | 25 |
| | 2A.5 | 2, 4, 6 | 318 | 70 | 378 | 397 | 300 | 247.5 | 288 | 107.5 | 305 | 80 | 369 | 69 | 85 | 133/123 | 234 | 200 | 25 |
| 225S | 2B.0 | 4 | 356 | 80 | 436 | 442 | 327 | 274 | 288 | 107.5 | 286 | 80 | 348 | 63 | 85 | 149/136 | 255 | 225 | 34 |
| 225M | 2B.2 | 2 | 356 | 80 | 436 | 442 | 327 | 274 | 288 | 107.5 | 311 | 80 | 373 | 63 | 85 | 149/136 | 255 | 225 | 34 |
| | | 4, 6 | | | | | | | | | | | | | | | | | |
| 250M | 2C.2 | 2 4, 6 | 406 | 90 | 490 | 488 | 373 | 310.5 | 342 | 123 | 349 | 100 | 421 | 92 | 84 | 169/158 | 269 | 250 | 40 |
| 280S | 2D.0 | 2 | 457 | 100 | 540 | 538 | 413 | 350.5 | 342 | 123 | 368 | 115 | 454 | 72 | 84 | 190/157 | 237 | 280 | 40 |
| | | 4, 6 | | | | | | | | | | | | | | | | | |
| 280M | 2D.2 | 2 4, 6 | 457 | 100 | 540 | 538 | 413 | 350.5 | 342 | 123 | 419 | 115 | 505 | 72 | 84 | 190/157 | 288 | 280 | 40 |
| 315S | 3A.0 | 2 | 508 | 120 | 610 | 608 | 482 | 401 | 401 | 148 | 406 | 165 | 520 | 75 | 110 | 216/180 | 351 | 315 | 50 |
| | | 4, 6 | | | | | | | | | | | | | | | | | |
| 315M | 3A.2 | 2 4, 6 | 508 | 120 | 610 | 608 | 482 | 401 | 401 | 148 | 457/508 | 165 | 668 | 75 | 110 | 216/309 | 480 | 315 | 50 |
| 315L | 3A.5/3A.6/ 3A.7 | 2 4, 6 | 508 | 120 | 610 | 608 | 482 | 401 | 401 | 148 | 457/508 | 165 | 668 | 75 | 110 | 216/258 | 480 | 315 | 50 |
| 355M | 3B.2 | 2 | 610 | 116 | 726 | 718 | 655 | 572 | 472 | 198.5 | 560/630 | - | 750 | - | 130 | 254 | 536 | 355 | 52 |
| | | 4, 6 | | | | | | | | | | | | | | | | | |
| 355L | 3B.3 | 2 | 610 | 116 | 726 | 718 | 655 | 572 | 472 | 198.5 | 560/630 | - | 750 | - | 130 | 254 | 536 | 355 | 52 |
| | | 4, 6 | | | | | | | | | | | | | | | | | |
| | | 2 | 610 | 116 | 726 | 718 | 655 | 572 | 472 | 198.5 | 560/630 | - | 750 | - | 130 | 254 | 536 | 355 | 52 |
| 355L | 3B.4 | 6 | 610 | 116 | 726 | 718 | 655 | 572 | 472 | 198.5 | 560/630 | - | 750 | - | 130 | 254 | 536 | 355 | 52 |
| | | 2 | 610 | 116 | 726 | 718 | 655 | 572 | 472 | 198.5 | 560/630 | - | 750 | - | 130 | 254 | 536 | 355 | 52 |
| | | 4, 6 | | | | | | | | | | | | | | | | | |
| 355L | 3B.5 | 2 | 610 | 116 | 726 | 718 | 655 | 572 | 472 | 198.5 | 560/630 | - | 750 | - | 130 | 254 | 536 | 355 | 52 |
| | | 4, 6 | | | | | | | | | | | | | | | | | |
| 355L | 3B.6 | 2 | 610 | 116 | 726 | 718 | 655 | 572 | 472 | 198.5 | 560/630 | - | 750 | - | 130 | 254 | 536 | 355 | 52 |
| | | 4, 6 | | | | | | | | | | | | | | | | | |

¹⁾ Measured across the bolt heads.

²⁾ This dimension is assigned in DIN EN 50347 to the frame size listed.

| For motor Frame size | Motor type | Number of poles | Dimension designation acc. to IEC | | | | | DE shaft extension | | | | | | |
|-------------------------|---------------|--------------------|--------------------------------------|------|-------|-------|-----|--------------------|-----|-----|-----|-----|------|------|
| | | | HH | K/K' | L | LC | LL | D | DB | E | EB | ED | F | GA |
| 80 M | OD.2 | 2 | 76 | 10 | 288 | 323 | 109 | 19 | M6 | 40 | 32 | 3.5 | 6 | 21.5 |
| | OD.2 | 4, 6 | 76 | 10 | 288 | 323 | 109 | 19 | M6 | 40 | 32 | 3.5 | 6 | 21.5 |
| | OD.3 | 2, 4, 6 | 76 | 10 | 288 | 323 | 109 | 19 | M6 | 40 | 32 | 3.5 | 6 | 21.5 |
| 90 S | OE.0 | 2, 4, 6 | 76 | 10 | 316 | 361 | 109 | 24 | M8 | 50 | 40 | 3.5 | 8 | 27 |
| 90 L | OE.4 | | 76 | 10 | 341 | 386 | 109 | 24 | M8 | 50 | 40 | 3.5 | 8 | 27 |
| 100 L | 1A.4 | 2, 4, 6 | 93.5 | 12 | 390 | 446 | 118 | 28 | M10 | 60 | 50 | 3.5 | 8 | 31 |
| | 1A.5 | 4 | 93.5 | 12 | 390 | 446 | 118 | 28 | M10 | 60 | 50 | 3.5 | 8 | 31 |
| 112 M | 1B.2 | 2, 4, 6 | 92 | 12 | 393.5 | 449.5 | 118 | 28 | M10 | 60 | 50 | 3.5 | 8 | 31 |
| 132 S | 1C.0 | 2, 4, 6 | 121.5 | 12 | 480 | 547 | 118 | 38 | M12 | 80 | 70 | 4 | 10 | 41 |
| | 1C.1 | 2 | 121.5 | 12 | 480 | 547 | 118 | 38 | M12 | 80 | 70 | 4 | 10 | 41 |
| 132 M | 1C.2 | 4, 6 | 121.5 | 12 | 525 | 592 | 118 | 38 | M12 | 80 | 70 | 4 | 10 | 41 |
| | 1C.3 | 6 | 121.5 | 12 | 525 | 592 | 118 | 38 | M12 | 80 | 70 | 4 | 10 | 41 |
| 160 M | 1D.2 | 2, 4, 6 | 159 | 15 | 614 | 701 | 158 | 42 | M16 | 110 | 100 | 5 | 12 | 45 |
| | 1D.3 | 2 | 159 | 15 | 614 | 701 | 158 | 42 | M16 | 110 | 100 | 5 | 12 | 45 |
| 160 L | 1D.4 | 2, 4, 6 | 159 | 15 | 674 | 761 | 158 | 42 | M16 | 110 | 100 | 5 | 12 | 45 |
| 180M | 1E.2 | 2, 4 | 158 | 15 | 683 | 801 | 158 | 48 | M16 | 110 | 100 | 5 | 14 | 51.5 |
| 180L | 1E.4 | 4, 6 | 158 | 15 | 718 | 836 | 158 | 48 | M16 | 110 | 100 | 5 | 14 | 51.5 |
| 200L | 2A.4 | 2, 6 | 202 | 19 | 772 | 892 | 215 | 55 | M20 | 110 | 100 | 5 | 16 | 59 |
| | 2A.5 | 2, 4, 6 | 202 | 19 | 772 | 892 | 215 | 55 | M20 | 110 | 100 | 5 | 16 | 59 |
| 225S | 2B.0 | 4 | 212 | 19 | 820 | 940 | 215 | 60 | M20 | 140 | 125 | 5 | 18 | 64 |
| 225M | 2B.2 | 2 | 212 | 19 | 815 | 935 | 215 | 55 | M20 | 110 | 100 | 5 | 16 | 59 |
| | | 4, 6 | | | 845 | 965 | | 60 | | 140 | 125 | | 18 | 64 |
| 250M | 2C.2 | 2 | 260 | 24 | 917 | 1037 | 246 | 60 | M20 | 140 | 125 | 5 | 18 | 64 |
| | | 4, 6 | | | | 1067 | | 65 | | | | | | 69 |
| 280S | 2D.0 | 2 | 262 | 24 | 976 | 1126 | 246 | 65 | M20 | 140 | 125 | 5 | 18 | 69 |
| | | 4, 6 | | | | | | 75 | | | | 5 | 20 | 79.5 |
| 280M | 2D.2 | 2 | 262 | 24 | 1027 | 1177 | 246 | 65 | M20 | 140 | 125 | 5 | 18 | 69 |
| | | 4, 6 | | | | | | 75 | | | | | 20 | 79.5 |
| 315S | 3A.0 | 2 | 291 | 28 | 1113 | 1265 | 296 | 65 | M20 | 140 | 125 | 6 | 18 | 69 |
| | | 4, 6 | | | 1143 | 1295 | | 80 | | 170 | 140 | | 22 | 85 |
| 315M | 3A.2 | 2 | 291 | 28 | 1293 | 1445 | 296 | 65 | M20 | 140 | 125 | 6 | 18 | 69 |
| | | 4, 6 | | | 1323 | 1475 | | 80 | | 170 | 140 | | 22 | 85 |
| 315L | 3A.4/ 3A.5 | 2 | 291 | 28 | 1293 | 1445 | 296 | 65 | M20 | 140 | 125 | 6 | 18 | 69 |
| | | 4, 6 | | | 1323 | 1475 | | 80 | | 170 | 140 | | 22 | 85 |
| 355M | 3B.2 | 2 | 298 | 28 | 1490 | 1652 | 397 | 75 | M20 | 140 | 125 | 6 | 20 | 79.5 |
| | | 4, 6 | | | 1520 | 1712 | | 95 | M24 | 170 | 140 | | 25 | 100 |
| | 3B.3 | 2 | 298 | 28 | 1490 | 1652 | 397 | 75 | M20 | 140 | 125 | 6 | 20 | 79.5 |
| 355L | 3B.4 | 2 | 298 | 28 | 1520 | 1712 | 397 | 95 | M24 | 170 | 140 | | 25 | 100 |
| | | 4, 6 | | | | | | 95 | | | | | 25 | 100 |
| | 3B.5 | 2 | 298 | 28 | 1490 | 1652 | 397 | 75 | M20 | 140 | 125 | 6 | 20 | 79.5 |
| | | 4, 6 | | | 1520 | 1712 | | 95 | M24 | 170 | 140 | | 25 | 100 |
| 3B.6 | 2 | 298 | 28 | 1490 | 1652 | 397 | 75 | M20 | 140 | 125 | 6 | 20 | 79.5 | |
| | 4, 6 | | | 1520 | 1712 | | 95 | M24 | 170 | 140 | | 25 | 100 | |

Flange dimensions

Type of construction – IM B5

Type of construction – IM B14

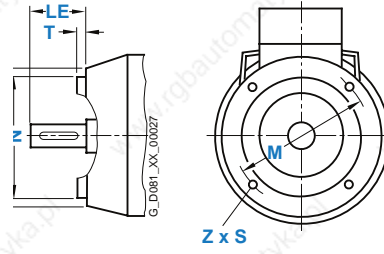
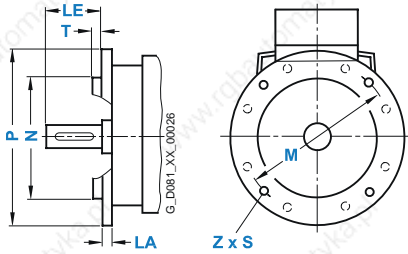

In DIN EN 50347, the frame sizes are allocated flange FF with through holes and flange FT with tapped holes. The designation of flange A and C according to DIN 42948 (invalid since September 2003) are also listed for information purposes. See the table below. (Z = the number of retaining holes).

| Frame size | Type of construction | Flange type | Flange with | | Dimension designation acc. to IEC | | | | | | | | | | | | | | |
|-------------------------------|--------------------------------|-----------------|--|----------------------|-----------------------------------|----|-----|-----|-----|------|-----|---|--|--|--|--|--|--|--|
| | | | through holes (FF/A) tapped holes (FT/C) acc. to DIN EN 50347 | acc. to DIN 42948 | LA | LE | M | N | P | S | T | Z | | | | | | | |
| Aluminum series – 1LA7 | | | | | | | | | | | | | | | | | | | |
| 63 M | IM B5, IM B35, IM V1, IM V3 | Flange | FF 115 | A 140 | 8 | 23 | 115 | 95 | 140 | 10 | 3 | 4 | | | | | | | |
| | IM B14, IM B34, IM V18, IM V19 | Standard flange | FT 75 | C 90 | – | 23 | 75 | 60 | 90 | M5 | 2.5 | 4 | | | | | | | |
| | IM B14, IM B34, IM V18, IM V19 | Special flange | FT 100 | C 120 | – | 23 | 100 | 80 | 120 | M6 | 3 | 4 | | | | | | | |
| 71 M | IM B5, IM B35, IM V1, IM V3 | Flange | FF 130 | A 160 | 9 | 30 | 130 | 110 | 160 | 10 | 3.5 | 4 | | | | | | | |
| | IM B14, IM B34, IM V18, IM V19 | Standard flange | FT 85 | C 105 | – | 30 | 85 | 70 | 105 | M6 | 2.5 | 4 | | | | | | | |
| | IM B14, IM B34, IM V18, IM V19 | Special flange | FT 115 | C 140 | – | 30 | 115 | 95 | 140 | M8 | 3 | 4 | | | | | | | |
| 80 M | IM B5, IM B35, IM V1, IM V3 | Flange | FF 165 | A 200 | 10 | 40 | 165 | 130 | 200 | 12 | 3.5 | 4 | | | | | | | |
| | IM B14, IM B34, IM V18, IM V19 | Standard flange | FT 100 | C 120 | – | 40 | 100 | 80 | 120 | M6 | 3 | 4 | | | | | | | |
| | IM B14, IM B34, IM V18, IM V19 | Special flange | FT 130 | C 160 | – | 40 | 130 | 110 | 160 | M8 | 3.5 | 4 | | | | | | | |
| 90 S, 90 L | IM B5, IM B35, IM V1, IM V3 | Flange | FF 165 | A 200 | 10 | 50 | 165 | 130 | 200 | 12 | 3.5 | 4 | | | | | | | |
| | IM B14, IM B34, IM V18, IM V19 | Standard flange | FT 115 | C 140 | – | 50 | 115 | 95 | 140 | M8 | 3 | 4 | | | | | | | |
| | IM B14, IM B34, IM V18, IM V19 | Special flange | FT 130 | C 160 | – | 50 | 130 | 110 | 160 | M8 | 3.5 | 4 | | | | | | | |
| 100 L | IM B5, IM B35, IM V1, IM V3 | Flange | FF 215 | A 250 | 11 | 60 | 215 | 180 | 250 | 14.5 | 4 | 4 | | | | | | | |
| | IM B14, IM B34, IM V18, IM V19 | Standard flange | FT 130 | C 160 | – | 60 | 130 | 110 | 160 | M8 | 3.5 | 4 | | | | | | | |
| | IM B14, IM B34, IM V18, IM V19 | Special flange | FT 165 | C 200 | – | 60 | 165 | 130 | 200 | M10 | 3.5 | 4 | | | | | | | |

| Frame size | Type of construction | Flange type | Flange with through holes (FF/A) tapped holes (FT/C) | | Dimension designation acc. to IEC | | | | | | | |
|--------------------------------|--------------------------------|---|--|-------------------|-----------------------------------|---------|-----|-----|-----|------|-----|---|
| | | | acc. to DIN EN 50347 | acc. to DIN 42948 | LA | LE | M | N | P | S | T | Z |
| Aluminum series – 1LE10 | | | | | | | | | | | | |
| 80 M | IM B5, IM B35, IM V1, IM V3 | Flange | FF 165 | A 200 | 10 | 40 | 165 | 130 | 200 | 12 | 3.5 | 4 |
| | IM B14, IM B34, IM V18, IM V19 | Standard flange | FT 100 | C 120 | – | 40 | 100 | 80 | 120 | M6 | 3 | 4 |
| 90 S, 90 L | IM B5, IM B35, IM V1, IM V3 | Flange | FF 165 | A 200 | 10 | 50 | 165 | 130 | 200 | 12 | 3.5 | 4 |
| | IM B14, IM B34, IM V18, IM V19 | Standard flange | FT 115 | C 140 | – | 50 | 115 | 95 | 140 | M8 | 3 | 4 |
| 100 L | IM B5, IM B35, IM V1, IM V3 | Flange | FF 215 | A 250 | 11 | 60 | 215 | 180 | 250 | 14.5 | 4 | 4 |
| | IM B14, IM B34, IM V18, IM V19 | Standard flange | FT 130 | C 160 | – | 60 | 130 | 110 | 160 | M8 | 3.5 | 4 |
| | IM B14, IM B34, IM V18, IM V19 | Special flange (next larger standard flange) | FT 165 | C 200 | – | 60 | 165 | 130 | 200 | M10 | 3.5 | 4 |
| 112 M | IM B5, IM B35, IM V1, IM V3 | Flange | FF 215 | A 250 | 11 | 60 | 215 | 180 | 250 | 14.5 | 4 | 4 |
| | IM B14, IM B34, IM V18, IM V19 | Standard flange | FT 130 | C 160 | – | 60 | 130 | 110 | 160 | M8 | 3.5 | 4 |
| | IM B14, IM B34, IM V18, IM V19 | Special flange (next larger standard flange) | FT 165 | C 200 | – | 60 | 165 | 130 | 200 | M10 | 3.5 | 4 |
| 132 S, 132 M | IM B5, IM B35, IM V1, IM V3 | Flange | FF 265 | A 300 | 12 | 80 | 265 | 230 | 300 | 14.5 | 4 | 4 |
| | IM B14, IM B34, IM V18, IM V19 | Standard flange | FT 165 | C 200 | – | 80 | 165 | 130 | 200 | M10 | 3.5 | 4 |
| | IM B14, IM B34, IM V18, IM V19 | Special flange (next larger standard flange) | FT 215 | C 250 | – | 80 | 215 | 180 | 250 | M12 | 4 | 4 |
| 160 M, 160 L | IM B5, IM B35, IM V1, IM V3 | Flange | FF 300 | A 350 | 13 | 110 | 300 | 250 | 350 | 18.5 | 5 | 4 |
| | IM B14, IM B34, IM V18, IM V19 | Standard flange | FT 215 | C 250 | – | 110 | 215 | 180 | 250 | M12 | 4 | 4 |
| Cast Iron series – 1LE0 | | | | | | | | | | | | |
| 80 | IM B5, IM B35, IMV1, IM V3 | Flange | FF 165 | A 200 | 10 | 40 | 165 | 130 | 200 | 12 | 3.5 | 4 |
| | IM B14, IM V18, IM V19 | Standard flange | FT 100 | C 120 | - | 40 | 100 | 80 | 120 | M 6 | 3 | 4 |
| 90 | IM B5, IM B35, IMV1, IM V3 | Flange | FF 165 | A 200 | 10 | 50 | 165 | 130 | 200 | 12 | 3.5 | 4 |
| | IM B14, IM V18, IM V19 | Standard flange | FT 115 | C 140 | - | 50 | 115 | 95 | 140 | M 8 | 3 | 4 |
| 100 | IM B5, IM B35, IMV1, IM V3 | Flange | FF 215 | A 250 | 11 | 60 | 215 | 180 | 250 | 14.5 | 4 | 4 |
| | IM B14, IM V18, IM V19 | Standard flange | FT 130 | C 160 | - | 60 | 130 | 110 | 160 | M 8 | 3.5 | 4 |
| 112 | IM B5, IM B35, IMV1, IM V3 | Flange | FF 215 | A 250 | 11 | 60 | 215 | 180 | 250 | 14.5 | 4 | 4 |
| | IM B14, IM V18, IM V19 | Standard flange | FT 130 | C 160 | - | 60 | 130 | 110 | 160 | M 8 | 3.5 | 4 |
| 132 | IM B5, IM B35, IMV1, IM V3 | Flange | FF 265 | A 300 | 12 | 80 | 265 | 230 | 300 | 14.5 | 4 | 4 |
| | IM B14, IM V18, IM V19 | Standard flange | FT 165 | C 200 | - | 80 | 165 | 130 | 200 | M 10 | 3.5 | 4 |
| 160 | IM B5, IM B35, IMV1, IM V3 | Flange | FF 300 | A 350 | 13 | 110 | 300 | 250 | 350 | 18.5 | 5 | 4 |
| | IM B14, IM V18, IM V19 | Standard flange | FT 215 | C 250 | - | 110 | 215 | 180 | 250 | M 12 | 4 | 4 |
| 180 | IM B5, IM B35, IMV1, IM V3 | Flange | FF 300 | A 350 | 15 | 110 | 300 | 250 | 350 | 18.5 | 5 | 4 |
| 200 | IM B5, IM B35, IMV1, IM V3 | Flange | FF 350 | A 400 | 17 | 110 | 350 | 300 | 400 | 18.5 | 5 | 4 |
| 225 | IM B5, IM B35, IMV1, IM V3 | Flange | FF 400 | A 450 | 20 | 110/140 | 400 | 350 | 450 | 18.5 | 5 | 8 |
| 250 | IM B5, IM B35, IMV1, IM V3 | Flange | FF 500 | A 550 | 22 | 140 | 500 | 450 | 550 | 18.5 | 5 | 8 |
| 280 | IM B5, IM B35, IMV1, IM V3 | Flange | FF 500 | A 550 | 22 | 140 | 500 | 450 | 550 | 18.5 | 5 | 8 |
| 315 | IM B5, IM B35, IMV1, IM V3 | Flange | FF 600 | A 660 | 22 | 140/170 | 600 | 550 | 660 | 24 | 6 | 8 |
| 355 | IM B5, IM B35, IMV1, IM V3 | Flange | FF 740 | A 800 | 22 | 140/170 | 740 | 680 | 800 | 24 | 6 | 8 |

User parts

User Parts Selection

| Aluminum | | Series | | | | | |
|---|---|-----------|-----------|--|--|--|--|
| SIMOTICS GP 1LA7 Standard Efficiency IE1 | 1 | available | available | | | | |
| SIMOTICS GP 1LE10 Standard Efficiency IE1 | 2 | | | | | | |
| SIMOTICS GP 1LE10 High Efficiency IE2 | 3 | | available | | | | |
| Cast Iron | | | | | | | |
| SIMOTICS GP 1LE0 Standard Efficiency IE1 | 4 | | available | | | | |
| SIMOTICS GP 1LE0 High Efficiency IE2 | 5 | | available | | | | |

| | | Frame size | 63 | 71 | 80 | 90 | 100 |
|--------------------------|-------|------------|--|----|----|----|-----|
| | | | Part number / units per package | | | | |
| Bearings | | | Bearings are commodity items and not sold by Siemens; refer to bearing selection for types | | | | |
| | 1 | | – | – | – | – | – |
| Pre-load washer | 2 / 3 | | – | – | – | – | – |
| | 4 / 5 | | – | – | ✓ | ✓ | ✓ |
| Endshield drive-end B3 | 1 | | ✓ | ✓ | ✓ | ✓ | – |
| | 2 / 3 | | – | – | – | – | ✓ |
| Endshield drive-end B5 | 4 / 5 | | – | – | ✓ | ✓ | ✓ |
| | 1 | | – | – | – | – | – |
| Endshield drive-end B14 | 2 / 3 | | – | – | – | – | ✓ |
| | 4 / 5 | | – | – | ✓ | ✓ | ✓ |
| Flange drive-end B5 | 1 | | ✓ | ✓ | ✓ | ✓ | – |
| | 2 / 3 | | – | – | – | – | – |
| Flange drive-end B14 | 4 / 5 | | – | – | – | – | – |
| | 1 | | ✓ | ✓ | ✓ | ✓ | – |
| Fan cover ^(a) | 2 / 3 | | – | – | ✓ | ✓ | ✓ |
| | 4 / 5 | | – | – | ✓ | ✓ | ✓ |
| Fan – 2-pole | 1 | | ✓ | ✓ | ✓ | ✓ | – |
| | 2 / 3 | | – | – | ✓ | ✓ | ✓ |
| Fan – 4-pole | 4 / 5 | | – | – | ✓ | ✓ | ✓ |
| | 1 | | ✓ | ✓ | ✓ | ✓ | – |
| Fan – 6-pole | 2 / 3 | | – | – | ✓ | ✓ | ✓ |
| | 4 / 5 | | ✓ | ✓ | ✓ | ✓ | ✓ |
| Terminal board | 1 | | ✓ | ✓ | ✓ | ✓ | – |
| | 2 / 3 | | – | – | – | – | ✓ |
| Canopy | 4 / 5 | | – | – | ✓ | ✓ | ✓ |
| | 1 | | ✓ | ✓ | ✓ | ✓ | – |

Note:

The Siemens warranty is valid for all motors which are originally supplied from the Siemens factory. Any modification will result in the nameplate no longer describing the physical build. Any such local adaptation is at the discretion of the user and the quality and func-

tionality is a result of his work. We strongly recommend an additional nameplate to be fixed to the cowl describing those changes referencing the responsible workshop. That workshop carries the warranty for the motor and the associated modification.



The parts required for simple modifications of the flange type or replacing parts broken during bearing change are readily available. The retrofitting of an encoder is a common modification. In order to make it easier, we offer the 1LE0 series with a non-drive end shaft mounting facility and the metal fan cover which has been prepared for modification.

| available | | | available | | | | | | available |
|-----------|------------------|------------------|-----------|-----|-----|-----|-----|-----|-----------|
| available | | | available | | | | | | available |
| 112 | 132 | 160 | 180 | 200 | 225 | 250 | 280 | 315 | 355 |
| - | - | - | - | - | - | - | - | - | - |
| - | - | - | - | - | - | - | - | - | - |
| ✓ | ✓ | ✓ | ✓ | ✓ | ✓ | ✓ | ✓ | ✓ | ✓ |
| - | - | - | - | - | - | - | - | - | - |
| ✓ | ✓ | ✓ | ✓ | ✓ | ✓ | ✓ | ✓ | ✓ | ✓ |
| ✓ | ✓ | ✓ | ✓ | ✓ | ✓ | ✓ | ✓ | ✓ | ✓ |
| - | - | - | - | - | - | - | - | - | - |
| ✓ | ✓ | ✓ | ✓ | ✓ | ✓ | ✓ | ✓ | ✓ | ✓ |
| ✓ | ✓ | ✓ | ✓ | ✓ | ✓ | ✓ | ✓ | ✓ | ✓ |
| - | - | - | - | - | - | - | - | - | - |
| - | - | - | - | - | - | - | - | - | - |
| - | - | - | - | - | - | - | - | - | - |
| - | - | - | - | - | - | - | - | - | - |
| - | - | - | - | - | - | - | - | - | - |
| - | - | - | - | - | - | - | - | - | - |
| ✓ | ✓ | ✓ | - | - | - | - | - | - | - |
| ✓ | ✓ | ✓ | ✓ | ✓ | ✓ | ✓ | ✓ | ✓ | ✓ |
| - | - | - | - | - | - | - | - | - | - |
| ✓ | ✓ | ✓ | ✓ | ✓ | ✓ | ✓ | ✓ | ✓ | ✓ |
| - | - | - | - | - | - | - | - | - | - |
| ✓ | ✓ ^(b) | ✓ ^(b) | - | - | - | - | - | - | - |
| ✓ | ✓ | ✓ | ✓ | ✓ | ✓ | ✓ | ✓ | ✓ | ✓ |
| - | - | - | - | - | - | - | - | - | - |
| ✓ | ✓ | ✓ | ✓ | ✓ | ✓ | ✓ | ✓ | ✓ | ✓ |
| ✓ | ✓ | ✓ | ✓ | ✓ | ✓ | ✓ | ✓ | ✓ | ✓ |
| - | - | - | - | - | - | - | - | - | - |
| ✓ | ✓ | ✓ | ✓ | ✓ | ✓ | ✓ | ✓ | ✓ | ✓ |
| ✓ | ✓ | ✓ | ✓ | ✓ | ✓ | ✓ | ✓ | ✓ | ✓ |
| - | - | - | - | - | - | - | - | - | - |
| ✓ | ✓ | ✓ | ✓ | ✓ | ✓ | ✓ | ✓ | ✓ | ✓ |
| ✓ | ✓ | ✓ | ✓ | ✓ | ✓ | ✓ | ✓ | ✓ | ✓ |

✓ Available
 - Not available

^(a) Plastic fan cover for 1LA7 and 1LE10 series, sheet metal fan cover for 1LE0 series.
^(b) Fan for 4-pole efficiency IE2.

Handling and storage

When lifting the motors, always use the lifting eyes provided. Prior to lifting the motor make sure that the lifting eyes are installed correctly and tightened. Never lift a motor using the rotor shaft and fan cowling. In addition, care must be taken during lifting and lowering of the motor to avoid any shocks or vibrations which can result in bearing damages.

It is recommended that all motor be stored in a dry, dust free environment and free of excessive vibrations.

If the DE and NDE bearings are of the sealed types, it is recommended that they are replaced if storage has exceeded 2 years from date of motor manufacture. If the motors have the regreasable bearings, then the recommendation is to replace the grease after 2 years of storage.

The service life of the motor can be considerably reduced if the storage period extends beyond 2 years in environments with high moisture and dirt. If necessary, the insulation resistance of the winding could be measured to determine the health of the motor prior to installation and start-up.

Machined surfaces (flange, DE rotor shaft) are treated at the factory with an anti corrosive agent to prevent rusting. However, these surfaces should be retreated during storage as deemed necessary. It is recommended that the motor shaft is rotated by hand on a frequent basis to ensure even grease distribution.

Notes

Siemens AG
Industry Sector
Drive Technologies Division
Large Drives
Postfach 4848
90026 NÜRNBERG
GERMANY

www.siemens.com/motors

Subject to change without prior notice
MP.R2.AA.DIST.RI.2.01
BR 0812 64 En
© Siemens AG 2012

The information provided in this brochure contains descriptions or characteristics of performance which in case of actual use do not always apply as described or which may change as a result of further development of the products. An obligation to provide the respective characteristics shall only exist if expressly agreed in the terms of contract. Availability and technical specifications are subject to change without notice.

All product designations may be trademarks or product names of Siemens AG or supplier companies whose use by third parties for their own purposes could violate the rights of the owners.