

BERO Proximity Switches

BERO 3RG4 Inductive Proximity Switches

Introduction

Principle of operation

The inductive BERO sensors are position switches that can be operated without contact, that contain no mechanical parts subject to wear and that are mainly insensitive to environmental conditions.

They are used in applications with stringent requirements for reliability, switch point accuracy, service life, number of switching operations, operating speed, and so on.

A high-frequency alternating field is generated in the BERO and emerges at the sensing face. The physical size of this alternating field determines the sensing range of the device. When a material that is a good conductor of electricity and/or

magnetism comes into close proximity with the sensing surface, the field is damped. Both states (field damped or undamped) are evaluated in the BERO and result in a change in the output state of the switch.

Application

The inductive BERO proximity switches are classified in accordance with their applications or their technical characteristics:

BERO for standard duty (3 or 4-wire)

See page 10/26.

- Rated operational voltage: DC 15 to 34 V
3RG46: DC 10 to 30 V
- Output
 - 3-wire BERO: 1 NO or 1 NC up to 200 mA
 - 4-wire BERO: 1 NO and 1 NC (non-equivalent), pnp up to 200 mA
- Switching frequency up to 3000 Hz (Ø 4 mm)
- Operating distance acc. to standard
- The actuation distance is between 0 and 81% of the rated operating distance.

Optimized for solid-state inputs (PLC)

See page 10/32.

- Rated operational voltage: DC 15 to 34 V,
- Output
 - 2-wire BERO: 1 NO, up to 25 mA
- Off-state current and voltage drop to suit PLC inputs
- Switching frequency up to 1500 Hz (Ø 8 mm, M 8),
- Operating distance acc. to standard
- The actuation distance is between 0 and 81% of the rated operating distance.

Advantages:

- Minimum wiring overheads
- Direct replacement of mechanical position switches possible in installations that are not safety-oriented
- Power is supplied from the PLC input
- npn as well as pnp switching

BERO for extra duty

See page 10/33.

- Rated operational voltage:
 - 3-wire BERO: DC 10 to 65 V
 - 2-wire BERO: AC/DC 20 to 320 V,
- Output
 - 3-wire BERO: 1 NO or 1 NC, pnp up to 300 mA
 - 2-wire BERO: 1 NO or 1 NC, resistive load up to 300 mA
- Switching frequency up to 5000 Hz (M 8)
- The actuation distance is between 0 and 81% of the rated operating distance.

Advantages:

- Problem-free adaptation to different rated operational currents
- Insensitive to voltage deviations

BERO for extreme environment (IP 68)

See page 10/36.

- Rated operational voltage:
 - 2-wire BERO: AC/DC 20 to 320 V,
 - 3-wire BERO: DC 15 to 34 V, DC 10 to 65 V
 - 4-wire BERO: DC 15 to 34 V,
- Output
 - 3-wire BERO: 1 NO or 1 NC, pnp up to 300 mA
 - 4-wire BERO: 1 NO and 1 NC (non-equivalent), pnp up to 200 mA
- The actuation distance is between 0 and 81% of the rated operating distance.

Advantages:

- Can be used under extreme environmental conditions according to IP 68 by use of a well-sealed housing with a special potting compound.

BERO with greater rated operating distance

See page 10/38.

- Rated operational voltage: DC 10 to 65 V (for 3RG46: DC 10 to 30 V)
- Output
 - 3-wire BERO: 1 NO or 1 NC, pnp up to 300 mA
- Switching frequency up to 1000 Hz (Ø 6.5 mm),
- Operating distance considerably higher than standard: Up to 3 times the standard rated operating distance
- The actuation distance is between 0 and 81% of the rated operating distance.

Advantages

- Wide range of mounting adjustment
- A smaller type can be selected for the required operating distance
- Reduction of actuation distance is corrected for non-ferrous metals

No reduction factor

See page 10/41.

- Rated operational voltage:
 - 3-wire BERO: DC 10 to 30 V
- Output
 - 3-wire BERO: 1 NO, pnp up to 200 mA
- Switching frequency up to 3000 Hz

Advantages:

- No reduction factor for non-ferrous metals
- Magnetic field resistant, i.e. these BEROs are insensitive to welding current. Magnetic field resistant up to 160 mT r.m.s. = 21 kA at 25.4 mm; exceptions: 3RG46 48: 140 mT r.m.s. 3RG46 44: 140 mT r.m.s. 3RG46 43: 75 mT r.m.s.

BERO pressure-resistant up to 500 bar (7250 psi)

See page 10/43.

- Rated operational voltage: DC 10 to 30 V
- 3-wire BERO: 1 NO, pnp up to 200 mA
- Switching frequency up to 400 Hz
- Operating distance: 3 mm.

Advantages:

- Suitable for extreme dynamic mechanical stress
- Easy to install: BERO can be screw fastened against a stop, no adjustment required
- Sensing face seal is gas-tight

BERO with analogue output

See page 10/43.

- Rated operational current DC 10 to 30 V
- Output
 - Voltage output DC 0 to 5 V
 - Current output 1 to 5 mA,
- Short-circuit protection, inductive interference protection, total reverse polarity protection
- Non-linearized design
- Connection via cable or S12 connector

Application

BERO for DESINA

See page 10/43.

DESINA describes a comprehensive overall concept for the standardization and decentralization of the electrical and fluidic installation of machines and installations.

- Acc. to Specification 06
- Rated operational voltage:
 - 3-wire BERO DC 10 to 30 V
 - 2-wire BERO DC 10 to 55 V
- Output
 - 3-wire BERO: 1 NO, pnp up to 200 mA
 - 2-wire BERO: 1 NO, up to 200 mA
 - Additional diagnostics output, load rating up to 50 mA
- Switching frequency up to 3000 Hz

Advantages:

- Standardized connection technique
- Diagnostic functions
- Adjustment aid

BERO for AS-Interface

See page 10/43.

- For direct connection to AS-Interface
- Outputs:
 - Operating range
 - Safe operating distance
 - Coil monitoring

Advantages:

- Simple connection directly to AS-Interface.

BERO to NAMUR and DIN 19 234 standards

See page 10/44.

- Intrinsically safe for use in potentially explosive areas (not Zone 0)
- Rated operational voltage: DC 5 to 25 V (can be extended with series-connection switching devices)
- Output
 - 2-wire current loop for series connection of switching devices (continuous characteristic curve)
- Switching frequency up to 5000 Hz (Ø 4.5 mm, M 8)
- Operating distance acc. to standard

- The actuation distance is between 0 and 81% of the rated operating distance.

Advantages:

- Intrinsically safe, EEx ib IIC, certified by PTB (No. Ex-88.B.2145),
- Small types
- Matching SIMATIC NAMUR input modules
- Wire-break and short-circuit monitoring by series-connection switching devices

Applications in Zone 2

to DIN VDE 0165/2.91, Section 6.3

The proximity switches with the order designations

- **3RG40** . .
- **3RG41** . .
- **3RG46** . .

are permitted to be implemented in Zone 2 in accordance with DIN VDE 0165 Section 6.3.

The following requirements are met or must be complied with.

- The proximity switches operate without contact. No sparks or arcing occur during operation.
- The maximum surface temperature with reference to the

ambient temperature is +50 K.

- The requirements of the IP 54 degree of protection are met.
- For devices with plugs and connectors, they must be interlocked, such that plugging in and unplugging is only possible with the power turned off. A warning notice "Do not operate when live" must be applied to them.

In addition, the general requirements of the DIN VDE 0165 standard for the installation of electrical equipment in potentially explosive areas must be observed.

Approvals

3RG40 and 3RG41 devices with M 12 or M 18 connectors as well as terminal compartments are UL and CSA listed.

For a complete overview, see the Appendix.

Personal safety

The use of inductive BEROs is not permissible for applications in which the safety of persons is dependent on the function of the BERO.

Functions

Built-in protection

The protective circuits built into most BEROs (see selection data) make them easy to handle and protect the devices from damage.

Protection is possible against

- Wire-break (connection L- or L+),
- Spurious signals
- Short-circuit and overload (DC)
- Overvoltage peaks
- Swapped connectors
- Radio interference

Electromagnetic compatibility

All inductive BEROs meet the protection requirements of EMC guideline No. 89/336/EWG. This is verified by application of the standard EN 60 947-5-2 and certified by the appropriate authority.

The following EMC standards are applicable for the individual tests:

- ENV 50 140
- ENV 50 141
- EN 55 011
- EN 55 022

- EN 61 000-4-2
- EN 61 000-4-4

LEDs

The cylindrical BEROs (with the exception of BEROs for extreme environmental conditions and BEROs according to NAMUR) are equipped with one or two light emitting diodes (LEDs).

The yellow LEDs indicate the operating status, i.e.

- For the NO function: BERO damped = LED lit

- For the NC function: BERO not damped = LED lit

The green LED indicates that the operational voltage is applied. This function is only available in certain devices.

Design

Specifications

EN 60 947-5-2 (VDE 0660, Part 208)

Connectors

For the cylindrical types, 8 mm combined plugs or plugs with M 12 threads are offered as standard (3-pole or 4-pole). A cable plug is additionally required for the plug-and-socket connections, see Accessories. As an option, plugs with an M 18 thread (3-pole) are also offered for the M 18 and M 30 types.

Cables

In general, highly flexible cables with oil-resistant outer sheaths of polyurethane (PUR) are used that are 2 m long as standard.

For applications where cables come into contact with acids or alkalis, please order devices with PVC cables.

For devices used in applications to UL and CSA, PVC cables must be ordered.

Other cable lengths and materials are available on request.

Cable length

For the BERO proximity switches, long cables cause:

- Capacitive loading of the output
- Increased injection of interference.

Cables should be shorter than 300 m even under favourable conditions.

Cable routing

The connecting leads of the proximity switches should not be routed in a cable duct alongside cables that are used to switch inductive loads (e.g. contactor coils, solenoid valves or motors)

or that carry the currents of electronic motorized operating mechanisms. The lead lengths should be as short as possible; they can, however, be up to 300 m in length under the best conditions (minimal coupling capacitance, low interference voltage levels).

Interference can be reduced by means of the following measures:

- Clearance from interfering cables > 100 mm
- Shielding
- Connection of coils (of contactors, relays or solenoid valves) with RC elements or varistors.

BERO Proximity Switches

BERO 3RG4 Inductive Proximity Switches

Standard duty

Selection and ordering data

Rated operational voltage DC 15 to 34 V (3RG46: 10 to 30 V) • 3 or 4-wire • Degree of protection IP 67

	Rated operating distance	Form, dimensions	Embeddable in metal	Enclosure	Rated operational current	Connecting wires	Connection	Switching output function	DT	Order No.	Price	PG	
	mm	mm			mA					Preferred type			
	0.6	∅ 3 × 22	Shielded	Stainless steel	100	3	2 m cable, PUR, 3 × 0.055 mm ²	NO, pnp	▶	3RG46 03-2AB00		122	
	0.8	∅ 4 × 25	Shielded	Stainless steel	200		2 m cable, PUR, 3 × 0.14 mm ²	NO, pnp	▶	3RG46 00-1AB00		122	
	0.8	M 5 × 25	Shielded	Brass, nickel-pl.	200	3	2 m cable, PUR, 3 × 0.14 mm ²	NO, pnp	▶	3RG46 10-0AG00		122	
		NO, npn					A	3RG46 10-0GB00		122			
		M 5 × 38					8 mm combined plug, Type A, C	NO, pnp	▶	3RG46 10-7AG00		122	
		NO, npn	A	3RG46 10-7GB00		122							
	0.8	5 × 5 × 25	Shielded	Brass, nickel-pl.	200	3	2 m cable, PUR, 3 × 0.14 mm ²	NO, pnp	▶	3RG46 36-0AG00		122	
							NO, npn	A	3RG46 36-0GB00		122		
	1	M 8 × 50	Shielded	Stainless steel	200	3	2 m cable, PUR, 3 × 0.25 mm ²	NO, pnp	▶	3RG40 11-0AG00		122	
		NC, pnp					C	3RG40 11-0AF00		122			
		NO, npn					▶	3RG40 11-0GB00		122			
		M 8 × 52					8 mm combined plug, Type A, C	NO, pnp	▶	3RG40 11-7AG00		122	
						NC, pnp	C	3RG40 11-7AF00		122			
	M 8 × 55					M 12 connector, Type E, F	NO, pnp	▶	3RG40 11-3AG00		122		
							NC, pnp	C	3RG40 11-3AF00		122		
							NO, npn	C	3RG40 11-3GB00		122		
	1	M 8 × 50	Shielded	Stainless steel	50	4	2 m cable, PUR, 4 × 0.14 mm ²	NO + NC, pnp	▶	3RG40 11-0CC00		122	
		8 mm combined plug, Type B					NO + NC, C	3RG40 11-7CC00		122			
		M 12 connector, Type F					NO + NC, C	3RG40 11-3CC00		122			
	1.5	∅ 6.5 × 16	Shielded	Stainless steel	200	3	2 m cable, PUR, 3 × 0.14 mm ²	NO, pnp	▶	3RG46 01-1AB00		122	
		8 mm combined plug, Type A					NO, pnp	▶	3RG46 01-7AG00		122		
		∅ 6.5 × 20					NC, npn	A	3RG46 01-7GB00		122		
	1.5	M 8 × 16	Shielded	Brass, nickel-pl.	200	3	2 m cable, PUR, 3 × 0.14 mm ²	NO, pnp	▶	3RG46 11-0AG31		122	
		8 mm combined plug, Type A					NO, pnp	▶	3RG46 11-7AG31		122		
		NC, pnp					A	3RG46 11-7AF31		122			
		M 8 × 29					NO, npn	A	3RG46 11-7GB31		122		
	1.5	8 × 8 × 40	Shielded	Brass, nickel-pl.	200	3	2 m cable, PUR, 3 × 0.14 mm ²	NO, pnp	▶	3RG46 37-0AB00		122	
							NO, npn	X	3RG46 37-0GG00		122		
		8 × 8 × 59						8 mm combined plug, Type A	NO, pnp	A	3RG46 37-7AB00		122
								NC, pnp	A	3RG46 37-7AA00		122	
								NO, npn	A	3RG46 37-7GG00		122	
								NC, npn	A	3RG46 37-7GF00		122	
	1.5	∅ 6.5 × 35	Shielded	Stainless steel	200	3	2 m cable, PUR, 3 × 0.25 mm ²	NO, pnp	C	3RG40 50-0AG33		122	
								NC, pnp	C	3RG40 50-0AF33		122	
								NO, npn	C	3RG40 50-0GB33		122	
								NC, npn	C	3RG40 50-0GA33		122	
		∅ 6.5 × 45						8 mm combined plug, Type A	NO, pnp	C	3RG40 50-7AG33		122
								NC, pnp	C	3RG40 50-7AF33		122	
							NO, npn	C	3RG40 50-7GB33		122		
							NC, npn	C	3RG40 50-7GA33		122		
	1.5	∅ 6.5 × 50	Shielded	Stainless steel	200	3	2 m cable, PUR, 3 × 0.25 mm ²	NO, pnp	C	3RG40 50-0AG05		122	
								NC, pnp	C	3RG40 50-0AF05		122	
								NO, npn	C	3RG40 50-0GB05		122	
								NC, npn	C	3RG40 50-0GA05		122	
		∅ 6.5 × 52						8 mm combined plug, Type A	NO, pnp	C	3RG40 50-7AG05		122
								NC, pnp	C	3RG40 50-7AF05		122	
							NO, npn	C	3RG40 50-7GB05		122		
							NC, npn	X	3RG40 50-7GA05		122		

For comprehensive data and dimension drawings, see Catalogue NS BERO and the Internet: <http://www.siemens.de/bero>.

BERO Proximity Switches

BERO 3RG4 Inductive Proximity Switches

Standard duty

Selection and ordering data

Rated operational voltage DC 15 to 34 V • 3 or 4-wire • Degree of protection IP 67

Rated operating distance	Form, dimensions	Embeddable in metal	Enclosure	Rated operational current	Connecting wires	Connection	Switching output function	DT	Order No.	Price	PG
mm	mm			mA					Preferred type		
1.5	Ø 8 × 35	Shielded	Stainless steel	200	3	2 m cable, PUR, 3 × 0.25 mm ²	NO, pnp	▶	3RG40 51-0AG33	122	
							NC, pnp	▶	3RG40 51-0AF33	122	
	NO, npn						▶	3RG40 51-0GB33	122		
	NC, npn						▶	3RG40 51-0GA33	122		
	Ø 8 × 45					8 mm combined plug, Type A	NO, pnp	▶	3RG40 51-7AG33	122	
							NC, pnp	▶	3RG40 51-7AF33	122	
1.5	M 8 × 35	Shielded	Stainless steel	200	3	2 m cable, PUR, 3 × 0.25 mm ²	NO, pnp	▶	3RG40 11-0AG33	122	
							NC, pnp	▶	3RG40 11-0AF33	122	
	NO, npn						C	3RG40 11-0GB33	122		
	NC, npn						C	3RG40 11-0GA33	122		
	M 8 × 45					8 mm combined plug, Type A	NO, pnp	▶	3RG40 11-7AG33	122	
							NC, pnp	▶	3RG40 11-7AF33	122	
1.5	M 8 × 50	Shielded	Stainless steel	200	3	2 m cable, PUR, 3 × 0.25 mm ²	NO, pnp	▶	3RG40 11-0AG05	122	
							NC, pnp	▶	3RG40 11-0AF05	122	
	NO, npn						C	3RG40 11-0GB05	122		
	NC, npn						C	3RG40 11-0GA05	122		
	M 8 × 52					8 mm combined plug, Type A, C	NO, pnp	▶	3RG40 11-7AG05	122	
							NC, pnp	C	3RG40 11-7AF05	122	
M 8 × 55	M 12 connector, Type E, F	NO, npn	C	3RG40 11-3AG05	122						
		NC, npn	C	3RG40 11-3AF05	122						
1.5	M 8 × 50	Shielded	Stainless steel	50	4	2 m cable, PUR, 4 × 0.14 mm ²	NO + NC, pnp	C	3RG40 11-0CC05	122	
							NO + NC, C	3RG40 11-7CC05	122		
	M 8 × 52					8 mm combined plug, Type B	NO + NC, C	3RG40 11-3CC05	122		
							NO + NC, C	3RG40 11-3CC05	122		
	M 8 × 55					M 12 connector, Type F	NO, npn	C	3RG40 12-0AG33	122	
							NC, pnp	C	3RG40 12-0AF33	122	
2	M 12 × 35	Shielded	Brass, nickel-pl.	200	3	2 m cable, PUR, 3 × 0.25 mm ²	NO, npn	▶	3RG40 12-0AG33	122	
							NC, pnp	C	3RG40 12-0AF33	122	
	NO, npn						▶	3RG40 12-0GB33	122		
	NC, npn						C	3RG40 12-0GA33	122		
	M 12 × 45					M 12 connector, Type E, F	NO, pnp	▶	3RG40 12-3AG33	122	
							NC, pnp	C	3RG40 12-3AF33	122	
		NO, npn	▶	3RG40 12-3GB33	122						
		NC, npn	C	3RG40 12-3GA33	122						
2	M 12 × 50	Shielded	Brass, nickel-pl.	200	3	2 m cable, PUR, 3 × 0.25 mm ²	NO, pnp	▶	3RG40 12-0AG01	122	
							NC, pnp	C	3RG40 12-0AF01	122	
	NO, npn						▶	3RG40 12-0GB00	122		
	NC, npn						C	3RG40 12-0GA00	122		
	M 12 × 59					M 12 connector, Type E, F	NO, pnp	▶	3RG40 12-3AG01	122	
							NC, pnp	C	3RG40 12-3AF01	122	
		NO, npn	▶	3RG40 12-3GB00	122						
		NO + NC, C	3RG40 12-0CD10	122							
2	M 12 × 40	Shielded	Brass, nickel-pl.	50	4	2 m cable, PUR, 4 × 0.14 mm ²	NO + NC, C	3RG40 12-3CD11	122		
							NO + NC, C	3RG40 12-3CD11	122		
2	M 12 × 50	Shielded	Brass, nickel-pl.	200	4	2 m cable, PUR, 4 × 0.14 mm ²	NO + NC, pnp	▶	3RG40 12-0CD00	122	
							NO + NC, pnp	▶	3RG40 12-3CD00	122	

For comprehensive data and dimension drawings, see Catalogue NS BERO and the Internet: <http://www.siemens.de/bero>.

BERO Proximity Switches

BERO 3RG4 Inductive Proximity Switches

Standard duty

Selection and ordering data

Rated operational voltage DC 15 to 34 V • 3 or 4-wire • Degree of protection IP 67

	Rated operating distance	Form, dimensions	Embeddable in metal	Enclosure	Rated operational current	Connecting wires	Connection	Switching output function	DT	Order No.	Price	PG				
	mm	mm			mA					Preferred type						
	2	12 × 40 × 26	Shielded	Moulded plastic	200	3	2 m cable, PUR, 3 × 0.25 mm ²	NO, pnp	▶	3RG40 70-0AG45		122				
							8 mm combined plug, Type A	NO, pnp	▶	3RG40 70-7AG45		122				
	2	12 × 32 × 27	Shielded	Moulded plastic	200	4	2 m cable, PUR, 4 × 0.14 mm ²	NO + NC, pnp	▶		3RG40 71-0CD00		122			
	2	12 × 40 × 26	Shielded	Moulded plastic	200	3	2 m cable, PUR, 3 × 0.25 mm ²	NO, pnp	C		3RG40 70-0AG01		122			
											NC, pnp	C	3RG40 70-0AF01		122	
											8 mm combined plug, Type A	NO, pnp	C	3RG40 70-7AG01		122
											M 12 connector, Type E, F	NO, pnp	C	3RG40 70-3AG01		122
											NC, pnp	C	3RG40 70-3AF01		122	
	2	12 × 40 × 26	Shielded	Moulded plastic	200	4	2 m cable, PUR, 4 × 0.14 mm ²	NO + NC, pnp	▶		3RG40 70-0CD00		122			
											8 mm combined plug, Type A	NO + NC, pnp	C	3RG40 70-7CD01		122
											8 mm combined plug, Type A	NO + NC, pnp	C	3RG40 70-7CD02		122
M 12 connector, Type E, F											NO + NC, pnp	C	3RG40 70-3CD00		122	
2.5	∅ 6.5 × 35	Unshielded	Stainless steel	200	3	2 m cable, PUR, 3 × 0.25 mm ²	NO, pnp	C	3RG40 60-0AG33		122					
							NC, pnp	C	3RG40 60-0AF33		122					
							NO, npn	X	3RG40 60-0GB33		122					
							NC, npn	X	3RG40 60-0GA33		122					
							8 mm combined plug, Type A	NO, pnp	C	3RG40 60-7AG33		122				
							NC, pnp	C	3RG40 60-7AF33		122					
	∅ 6.5 × 45	Unshielded	Stainless steel	200	3	2 m cable, PUR, 3 × 0.25 mm ²	NO, npn	X	3RG40 60-7GB33		122					
							NC, npn	X	3RG40 60-7GA33		122					
							8 mm combined plug, Type A	NO, pnp	C	3RG40 21-7AG33		122				
							NC, pnp	C	3RG40 21-7AF33		122					
							NO, npn	C	3RG40 21-7GB33		122					
							NC, npn	C	3RG40 21-7GA33		122					
2.5	M 8 × 35	Unshielded	Stainless steel	200	3	2 m cable, PUR, 3 × 0.25 mm ²	NO, pnp	C	3RG40 21-0AG33		122					
							NC, pnp	C	3RG40 21-0AF33		122					
							NO, npn	C	3RG40 21-0GB33		122					
							NC, npn	C	3RG40 21-0GA33		122					
							8 mm combined plug, Type A	NO, pnp	C	3RG40 21-7AG33		122				
							NC, pnp	C	3RG40 21-7AF33		122					
	M 8 × 45	Unshielded	Stainless steel	200	3	2 m cable, PUR, 3 × 0.25 mm ²	NO, npn	C	3RG40 21-7GB33		122					
							NC, npn	C	3RG40 21-7GA33		122					
							8 mm combined plug, Type A	NO, pnp	C	3RG40 72-7AG33		122				
							NC, pnp	C	3RG40 72-7AF33		122					
							NO, npn	C	3RG40 72-7GB33		122					
							NC, npn	C	3RG40 72-7GA33		122					
2.5	M 14 × 56	Shielded	Moulded plastic	200	3	2 m cable, PUR, 3 × 0.25 mm ²	NO, npn	C	3RG40 72-0GB00		122					
							NC, npn	▶	3RG40 72-0GA00		122					
	M 14 × 66	Shielded	Moulded plastic	200	4	2 m cable, PUR, 4 × 0.14 mm ²	NO + NC, pnp	▶		3RG40 72-0CD00		122				
										M 12 connector, Type E, F	NO, npn	C	3RG40 72-3GB00		122	
4	M 12 × 35	Unshielded	Brass, nickel-pl.	200	3	2 m cable, PUR, 3 × 0.25 mm ²	NO, pnp	C	3RG40 22-0AG33		122					
							NC, pnp	C	3RG40 22-0AF33		122					
							NO, npn	C	3RG40 22-0GB33		122					
							NC, npn	C	3RG40 22-0GA33		122					
							8 mm combined plug, Type A	NO, pnp	▶	3RG40 22-3AG33		122				
							NC, pnp	C	3RG40 22-3AF33		122					
	M 12 × 45	Unshielded	Brass, nickel-pl.	200	3	2 m cable, PUR, 3 × 0.25 mm ²	NO, npn	C	3RG40 22-3GB33		122					
							NC, npn	C	3RG40 22-3GA33		122					
							M 12 connector, Type E, F	NO, pnp	▶	3RG40 22-3AG33		122				
							NC, pnp	C	3RG40 22-3AF33		122					
							NO, npn	C	3RG40 22-3GB33		122					
							NC, npn	C	3RG40 22-3GA33		122					

For comprehensive data and dimension drawings, see Catalogue NS BERO and the Internet: <http://www.siemens.de/bero>.





BERO Proximity Switches

BERO 3RG4 Inductive Proximity Switches

Standard duty

Selection and ordering data

Rated operational voltage DC 15 to 34 V (3RG40 75: 10 to 30 V) • 3 or 4-wire • Degree of protection IP 67

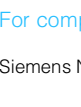
Rated operating distance	Form, dimensions	Embeddable in metal	Enclosure	Rated operational current	Connecting wires	Connection	Switching output function	DT	Order No.	Price	PG	
									Preferred type			
	4	M 12 × 56	Un-shielded	Brass, nickel-pl.	200	3	2 m cable, PUR, 3 × 0.25 mm ²	NO, pnp NC, pnp NO, npn NC, npn	▶	3RG40 22-0AG01	122	
		3RG40 22-0AF01								122		
			M 12 × 65									
							M 12 connector, Type E, F			▶	3RG40 22-3AG01	122
										▶	3RG40 22-3AF01	122
										▶	3RG40 22-3GB00	122
										▶	3RG40 22-3GA00	122
	4	M 12 × 40	Un-shielded	Brass, nickel-pl.	50	4	2 m cable, PUR, 4 × 0.14 mm ²	NO + NC, pnp	▶	3RG40 22-0CD10	122	
		3RG40 22-3CD11								122		
			M 12 × 50									
							M 12 connector, Type F					
	4	M 12 × 56	Un-shielded	Brass, nickel-pl.	200	4	2 m cable, PUR, 4 × 0.14 mm ²	NO + NC, pnp	▶	3RG40 22-0CD00	122	
		3RG40 22-3CD00								122		
			M 12 × 65									
							M 12 connector, Type F					
	5	M 14 × 56	Un-shielded	Moulded plastic	200	4	2 m cable, PUR, 4 × 0.14 mm ²	NO + NC, pnp	▶	3RG40 82-0CD00	122	
		3RG40 82-3CD00								122		
			M 14 × 66									
							M 12 connector, Type F					
	5	M 18 × 35	Shielded	Brass, nickel-pl.	200	3	2 m cable, PUR, 3 × 0.25 mm ²	NO, pnp NC, pnp NO, npn NC, npn	▶	3RG40 13-0AG33	122	
		3RG40 13-0AF33								122		
	5	M 18 × 35	Shielded	Brass, nickel-pl.	200	3	2 m cable, PUR, 3 × 0.25 mm ²	NO, pnp NC, pnp NO, npn NC, npn	▶	3RG40 13-0AG01	122	
		3RG40 13-0AF01								122		
	5	M 18 × 54	Shielded	Brass, nickel-pl.	200	3	2 m cable, PUR, 3 × 0.25 mm ²	NO, pnp NC, pnp NO, npn NC, npn	▶	3RG40 13-0AG01	122	
		3RG40 13-0AF01								122		
	5	M 18 × 54	Shielded	Brass, nickel-pl.	200	4	2 m cable, PUR, 4 × 0.14 mm ²	NO + NC, pnp	▶	3RG40 13-0CD00	122	
		3RG40 13-3CD00								122		
			M 18 × 69									
							M 12 connector, Type F					
	5	∅ 18 × 9.9	Shielded	Moulded plastic	50	3	Single cores 0.5 m, PUR, 3 × 0.25 mm ²	NO, pnp NC, pnp NO, npn	▶	3RG40 75-0AJ00	122	
		3RG40 75-0AH00								122		
	8	M 18 × 35	Un-shielded	Brass, nickel-pl.	200	3	2 m cable, PUR, 3 × 0.25 mm ²	NO, pnp NC, pnp NO, npn NC, npn	▶	3RG40 23-0AG33	122	
		3RG40 23-0AF33								122		
	8	M 18 × 35	Un-shielded	Brass, nickel-pl.	200	3	2 m cable, PUR, 3 × 0.25 mm ²	NO, pnp NC, pnp NO, npn NC, npn	▶	3RG40 23-0AG33	122	
		3RG40 23-0AF33								122		
	8	M 18 × 45	Un-shielded	Brass, nickel-pl.	200	3	2 m cable, PUR, 3 × 0.25 mm ²	NO, pnp NC, pnp NO, npn NC, npn	▶	3RG40 23-3AG33	122	
		3RG40 23-3AF33								122		

For comprehensive data and dimension drawings, see Catalogue NS BERO and the Internet: <http://www.siemens.de/bero>.

BERO Proximity Switches

BERO 3RG4 Inductive Proximity Switches

Standard duty

Selection and ordering data

Rated operational voltage DC 15 to 34 V (3RG46: 10 to 36 V) • 3 or 4-wire • Degree of protection IP 67
(with terminal compartment: IP 65)

	Rated operating distance	Form, dimensions	Embeddable in metal	Enclosure	Rated operational current	Connecting wires	Connection	Switching output function	DT	Order No.	Price	PG
	mm	mm			mA					Preferred type		
	8	M 18 × 54	Unshielded	Brass, nickel-pl.	200	3	2 m cable, PUR, 3 × 0.25 mm ²	NO, pnp NC, pnp NO, npn	▶ C C	3RG40 23-0AG01 3RG40 23-0AF01 3RG40 23-0GB00		122 122 122
		M 18 × 69					M 12 connector, Type E, F	NO, pnp NC, pnp NO, npn	C C C	3RG40 23-3AG01 3RG40 23-3AF01 3RG40 23-3GB00		122 122 122
		M 18 × 74					M 18 connector, Type P	NO, pnp NC, pnp	C C	3RG40 23-2AG01 3RG40 23-2AF01		122 122
	8	M 18 × 54	Unshielded	Brass, nickel-pl.	200	4	2 m cable, PUR, 4 × 0.14 mm ²	NO + NC, pnp	▶	3RG40 23-0CD00		122
		M 18 × 69					M 12 connector, Type F	NO + NC, pnp	C	3RG40 23-3CD00		122
		M 18 × 74					M 18 connector, Type P	NO + NC, pnp	C	3RG40 23-2CD00		122
	10	M 30 × 35	Shielded	Brass, nickel-pl.	200	3	2 m cable, PUR, 3 × 0.25 mm ²	NO, pnp NC, pnp NO, npn NC, npn	C C C C	3RG40 14-0AG33 3RG40 14-0AF33 3RG40 14-0GB33 3RG40 14-0GA33		122 122 122 122
		M 30 × 45					M 12 connector, Type E, F	NO, pnp NC, pnp NO, npn NC, npn	▶ C C C	3RG40 14-3AG33 3RG40 14-3AF33 3RG40 14-3GB33 3RG40 14-3GA33		122 122 122 122
	10	M 30 × 54	Shielded	Brass, nickel-pl.	200	3	2 m cable, PUR, 3 × 0.25 mm ²	NO, pnp NC, pnp NO, npn	▶ ▶ ▶	3RG40 14-0AG01 3RG40 14-0AF01 3RG40 14-0GB00		122 122 122
		M 30 × 69					M 12 connector, Type E, F	NO, pnp NC, pnp NO, npn	▶ C C	3RG40 14-3AG01 3RG40 14-3AF01 3RG40 14-3GB00		122 122 122
		M 30 × 84					M 18 connector, Type P	NO, pnp NC, pnp	C C	3RG40 14-2AG01 3RG40 14-2AF01		122 122
	10	M 30 × 54	Shielded	Brass, nickel-pl.	200	4	2 m cable, PUR, 4 × 0.14 mm ²	NO + NC, pnp	▶	3RG40 14-0CD00		122
	M 30 × 69					M 12 connector, Type F	NO + NC, pnp	C	3RG40 14-3CD00		122	
10	M 30 × 80	Shielded	Brass, nickel-pl.	300	4	M 12 connector, Type F	NO + NC, pnp	D	3RG40 14-3CD01		122	
10	Ø 20 × 62	Unshielded	Moulded plastic	250	3	With terminal compartment for cables 0.75 ... 2.5 mm ²	NO, pnp	A	3RG46 25-6AG00		122	
	15	M 30 × 35	Unshielded	Brass, nickel-pl.	200	3	2 m cable, PUR, 3 × 0.25 mm ²	NO, pnp NC, pnp NO, npn NC, npn	C C C C	3RG40 24-0AG33 3RG40 24-0AF33 3RG40 24-0GB33 3RG40 24-0GA33		122 122 122 122
		M 30 × 45					M 12 connector, Type E, F	NO, pnp NC, pnp NO, npn NC, npn	▶ C C C	3RG40 24-3AG33 3RG40 24-3AF33 3RG40 24-3GB33 3RG40 24-3GA33		122 122 122 122
	15	M 30 × 54	Unshielded	Brass, nickel-pl.	200	3	2 m cable, PUR, 3 × 0.25 mm ²	NO, pnp NC, pnp NO, npn NC, npn	▶ C C C	3RG40 24-0AG01 3RG40 24-0AF01 3RG40 24-0GB00 3RG40 24-0GA00		122 122 122 122
		M 30 × 69					M 12 connector, Type E, F	NO, pnp NC, pnp NO, npn NC, npn	▶ C C C	3RG40 24-3AG01 3RG40 24-3AF01 3RG40 24-3GB00 3RG40 24-3GA01		122 122 122 122
		M 30 × 84					M 18 connector, Type P	NO, pnp NC, pnp	C C	3RG40 24-2AG01 3RG40 24-2AF01		122 122
	15	M 30 × 54	Unshielded	Brass, nickel-pl.	200	3	2 m cable, PUR, 3 × 0.25 mm ²	NO, pnp NC, pnp NO, npn NC, npn	▶ C C C	3RG40 24-0AG01 3RG40 24-0AF01 3RG40 24-0GB00 3RG40 24-0GA00		122 122 122 122
	M 30 × 69					M 12 connector, Type E, F	NO, pnp NC, pnp NO, npn NC, npn	▶ C C C	3RG40 24-3AG01 3RG40 24-3AF01 3RG40 24-3GB00 3RG40 24-3GA01		122 122 122 122	
	M 30 × 84					M 18 connector, Type P	NO, pnp NC, pnp	C C	3RG40 24-2AG01 3RG40 24-2AF01		122 122	

For comprehensive data and dimension drawings, see Catalogue NS BERO and the Internet: <http://www.siemens.de/bero>.

BERO Proximity Switches

BERO 3RG4 Inductive Proximity Switches

Standard duty

Selection and ordering data

Rated operational voltage DC 15 to 34 V (3RG46: 10 to 36 V) • 3 or 4-wire • Degree of protection IP 67
(with terminal compartment: IP 65)

Rated operating distance	Form, dimensions	Embeddable in metal	Enclosure	Rated operational current	Connecting wires	Connection	Switching output function	DT	Order No.	Price	PG
mm	mm			mA					Preferred type		
15	M 30 × 54	Unshielded	Brass, nickel-pl.	200	4	2 m cable, PUR, 4 × 0.14 mm ²	NO + NC, pnp	▶	3RG40 24-0CD00	122	
	M 30 × 69								M 12 connector, Type F		
15	40 × 40 × 69 (incl. connectors)	Shielded	Moulded plastic	200	4	M 12 connector, Type F	NO + NC, pnp	▶	3RG40 38-3CD00	122	
									NO + NC, A npn		
15	40 × 40 × 120	Shielded	Moulded plastic	200	3	With terminal compartment for cables 0.5 ... 2.5 mm ²	NO, pnp	▶	3RG40 31-6AG01	122	
							NC, pnp	C	3RG40 31-6AF01		
							NO, npn	▶	3RG40 31-6GB00		
15	40 × 40 × 120	Shielded	Moulded plastic	200	4	With terminal compartment for cables 0.5 ... 2.5 mm ²	NO + NC, pnp	▶	3RG40 31-6CD00	122	
15	40 × 40 × 118	Shielded	Moulded plastic	200	4	With terminal compartment for cables 0.5 ... 2.5 mm ²	NO + NC, pnp	▶	3RG40 34-6CD00	122	
20	∅ 34 × 98	Unshielded	Moulded plastic	200	3	With terminal compartment for cables 0.75 ... 2.5 mm ²	NO or NC, pnp, programmable	A	3RG46 26-6AD00	122	
20	40 × 40 × 120	Unshielded	Moulded plastic	200	3	With terminal compartment for cables 0.5 ... 2.5 mm ²	NO, pnp	▶	3RG40 41-6AG01	122	
							NC, pnp	C	3RG40 41-6AF01		
							NO, npn	C	3RG40 41-6GB00		
20	40 × 40 × 120	Unshielded	Moulded plastic	200	4	With terminal compartment for cables 0.5 ... 2.5 mm ²	NO + NC, pnp	▶	3RG40 41-6CD00	122	
25	60 × 77 × 41	Shielded	Moulded plastic	200	4	With terminal compartment for cables 0.5 ... 2.5 mm ²	NO + NC, pnp	▶	3RG40 32-6CD00	122	
30	60 × 77 × 41	Unshielded	Moulded plastic	200	4	With terminal compartment for cables 0.5 ... 2.5 mm ²	NO + NC, pnp	C	3RG40 42-6CD00	122	
40	80 × 100 × 42	Unshielded	Moulded plastic	200	4	With terminal compartment for cables 0.5 ... 2.5 mm ²	NO + NC, pnp	C	3RG40 43-6CD00	122	



For comprehensive data and dimension drawings, see Catalogue NS BERO and the Internet: <http://www.siemens.de/bero>.

BERO Proximity Switches

BERO 3RG4 Inductive Proximity Switches

Optimized for solid-state inputs (PLC)

Selection and ordering data

Rated operational voltage DC 15 to 34 V • Rated operational current 25 mA • 2-wire • Degree of protection IP 67

	Rated operating distance	Form, dimensions	Embed-dable in metal	Enclosure	Connection	Switching output function	DT	Order No.	Price	PG
	mm	mm						▶ Preferred type		
	1	M 8 × 50	Shielded	Stainless steel	2 m cable, PUR, 2 × 0.25 mm ²	NO	▶	3RG40 11-0JB00		122
		M 8 × 52			8 mm combined plug, Type A	NO	C	3RG40 11-7JB00		122
		M 8 × 55			M 12 connector, Type E, F	NO	▶	3RG40 11-3JB00		122
	2	M 12 × 50	Shielded	Brass, nickel-pl.	2 m cable, PUR, 2 × 0.25 mm ²	NO	▶	3RG40 12-0JB00		122
		M 12 × 59			M 12 connector, Type E, F	NO	▶	3RG40 12-3JB00		122
	4	M 12 × 56	Un-shielded	Brass, nickel-pl.	2 m cable, PUR, 2 × 0.25 mm ²	NO	▶	3RG40 22-0JB00		122
		M 12 × 65			M 12 connector, Type E, F	NO	▶	3RG40 22-3JB00		122
	2.5	M 14 × 56	Shielded	Moulded plastic	2 m cable, PUR, 2 × 0.25 mm ²	NO	C	3RG40 72-0JB00		122
		M 14 × 66			M 12 connector, Type E, F	NO	C	3RG40 72-3JB00		122
	5	M 18 × 54	Shielded	Brass, nickel-pl.	2 m cable, PUR, 2 × 0.25 mm ²	NO	▶	3RG40 13-0JB00		122
		M 18 × 69			M 12 connector, Type E, F	NO	▶	3RG40 13-3JB00		122
		M 18 × 74			With M 18 connector, Type P	NO	C	3RG40 13-2JB00		122
	8	M 18 × 54	Un-shielded	Brass, nickel-pl.	2 m cable, PUR, 2 × 0.25 mm ²	NO	▶	3RG40 23-0JB00		122
		M 18 × 69			M 12 connector, Type E, F	NO	▶	3RG40 23-3JB00		122
		M 18 × 74			M 18 connector, Type P	NO	C	3RG40 23-2JB00		122
	10	M 30 × 54	Shielded	Brass, nickel-pl.	2 m cable, PUR, 2 × 0.25 mm ²	NO	▶	3RG40 14-0JB00		122
		M 30 × 69			M 12 connector, Type E, F	NO	C	3RG40 14-3JB00		122
		M 30 × 84			M 18 connector, Type P	NO	C	3RG40 14-2JB00		122
	15	M 30 × 54	Un-shielded	Brass, nickel-pl.	2 m cable, PUR, 2 × 0.25 mm ²	NO	▶	3RG40 24-0JB00		122
		M 30 × 69			M 12 connector, Type E, F	NO	C	3RG40 24-3JB00		122
		M 30 × 84			M 18 connector, Type P	NO	C	3RG40 24-2JB00		122
	15	40 × 40 × 120	Shielded	Moulded plastic	With terminal compartment for cables 0.5 ... 2.5 mm ²	NO	▶	3RG40 31-6JB00		122
	20	40 × 40 × 120	Un-shielded	Moulded plastic	With terminal compartment for cables 0.5 ... 2.5 mm ²	NO	▶	3RG40 41-6JB00		122

For comprehensive data and dimension drawings, see Catalogue NS BERO and the Internet: <http://www.siemens.de/bero>.

BERO Proximity Switches

BERO 3RG4 Inductive Proximity Switches

Extra duty

Selection and ordering data

Rated operational voltage AC 20 to 265 V / DC 20 to 320 V • 2-wire • Degree of protection IP 67
 Rated operational voltage DC 10 to 65 V • 3-wire • Degree of protection IP 67

Rated operating distance	Form, dimensions	Embeddable in metal	Enclosure	Rated operational current	Connecting wires	Connection	Switching output function	DT	Order No.	Price	PG						
mm	mm		mA						Preferred type								
1	M 8 × 57	Shielded	Stainless steel	200	3	2 m cable, PUR, 3 × 0.25 mm ²	NO, pnp	▶	3RG40 11-0AB00	122							
							NC, pnp	C	3RG40 11-0AA00	122							
	M 8 × 58							NO, pnp	▶	3RG40 11-7AB00	122						
								NC, pnp	C	3RG40 11-7AA00	122						
1	M 8 × 62	Shielded	Stainless steel	200	3	M 12 connector, Type E, F	NO, pnp	▶	3RG40 11-3AB00	122							
							NC, pnp	C	3RG40 11-3AA00	122							
	2						M 12 × 56	Shielded	Brass, nickel-pl.	200	2	2 m cable, PUR, 2 × 0.25 mm ²	NO	▶	3RG40 12-0KB00	122	
													NC	C	3RG40 12-0KA00	122	
	M 12 × 65					M 12 connector, Type E, F	NO	▶	3RG40 12-3KB00	122							
							NC	C	3RG40 12-3KA00	122							
1	M 12 × 56	Shielded	Brass, nickel-pl.	200	2	2 m cable, PUR, 2 × 0.25 mm ²	NO, pnp	▶	3RG40 12-0AB00	122							
							NC, pnp	▶	3RG40 12-0AA00	122							
				M 12 × 65	300	3	2 m cable, PUR, 3 × 0.25 mm ²	NO, pnp	▶	3RG40 12-0AB00	122						
									NC, pnp	▶	3RG40 12-0AA00	122					
	M 12 × 65					M 12 connector, Type E, F	NO, pnp	▶	3RG40 12-3AB00	122							
							NC, pnp	C	3RG40 12-3AA00	122							
4	M 12 × 62	Unshielded	Brass, nickel-pl.	200	2	2 m cable, PUR, 2 × 0.25 mm ²	NO	▶	3RG40 22-0KB00	122							
							NC	C	3RG40 22-0KA00	122							
				M 12 × 71	300	3	2 m cable, PUR, 3 × 0.25 mm ²	NO, pnp	▶	3RG40 22-0AB00	122						
									NC, pnp	C	3RG40 22-0AA00	122					
	M 12 × 62					M 12 connector, Type E, F	NO, pnp	▶	3RG40 22-3AB00	122							
							NC, pnp	C	3RG40 22-3AA00	122							
2.5	M 14 × 56	Shielded	Moulded plastic	200	2	2 m cable, PUR, 2 × 0.25 mm ²	NO	C	3RG40 72-0KB00	122							
							NC	C	3RG40 72-0KA00	122							
				M 14 × 66	300	3	2 m cable, PUR, 3 × 0.25 mm ²	NO, pnp	▶	3RG40 72-0AB00	122						
									NC, pnp	C	3RG40 72-0AA00	122					
	M 14 × 56					M 12 connector, Type E, F	NO, pnp	▶	3RG40 72-3AB00	122							
							NC, pnp	C	3RG40 72-3AA00	122							
5	M 14 × 56	Unshielded	Moulded plastic	300	3	2 m cable, PUR, 3 × 0.25 mm ²	NO, pnp	▶	3RG40 82-0AB00	122							
							NC, pnp	C	3RG40 82-0AA00	122							
	M 14 × 66					M 12 connector, Type E, F	NO, pnp	▶	3RG40 82-3AB00	122							
							NC, pnp	C	3RG40 82-3AA00	122							
5	M 18 × 54	Shielded	Brass, nickel-pl.	300	2	2 m cable, PUR, 2 × 0.25 mm ²	NO	▶	3RG40 13-0KB00	122							
							NC	▶	3RG40 13-0KA00	122							
							M 12 connector, Type E, F	NO	▶	3RG40 13-3KB00	122						
								NC	C	3RG40 13-3KA00	122						
				M 18 × 74	3	2	2 m cable, PUR, 3 × 0.25 mm ²	M 18 connector, Type P	NO	C	3RG40 13-2KB00	122					
									NC	C	3RG40 13-2KA00	122					
				M 18 × 54							NO, pnp	▶	3RG40 13-0AB00	122			
											NC, pnp	▶	3RG40 13-0AA00	122			
	M 18 × 69				M 12 connector, Type E, F	NO, pnp	▶	3RG40 13-3AB00	122								
						NC, pnp	C	3RG40 13-3AA00	122								
	M 18 × 74				M 18 connector, Type P	NO, pnp	C	3RG40 13-2AB00	122								
						NC, pnp	C	3RG40 13-2AA00	122								

For comprehensive data and dimension drawings, see Catalogue NS BERO and the Internet: <http://www.siemens.de/bero>.

BERO Proximity Switches

BERO 3RG4 Inductive Proximity Switches



Extra duty

Selection and ordering data

Rated operational voltage AC 20 to 265 V / DC 20 to 320 V (3RG 46: max. 250 V) • 2-wire • Degree of protection IP 67

(with terminal compartment: IP 65)

Rated operational voltage DC 10 to 65 V • 3-wire • Degree of protection IP 67 (with terminal compartment: IP 65)

	Rated operating distance	Form, dimensions	Embeddable in metal	Enclosure	Rated operational current	Connecting wires	Connection	Switching output function	DT	Order No.	Price	PG										
	mm	mm			mA					Preferred type												
	8	M 18 x 54	Un-shielded	Brass, nickel-pl.	300	2	2 m cable, PUR, 2 x 0.25 mm ²	NO	▶	3RG40 23-0KB00	122											
							NC	▶	3RG40 23-0KA00	122												
		M 18 x 69					M 12 connector, Type E, F	NO	▶	3RG40 23-3KB00	122											
							NC	▶	3RG40 23-3KA00	122												
		M 18 x 74					M 18 connector, Type P	NO	▶	3RG40 23-2KB00	122											
		M 18 x 54					3	2 m cable, PUR, 3 x 0.25 mm ²	NO, pnp	▶	3RG40 23-0AB00	122										
								NC, pnp	▶	3RG40 23-0AA00	122											
M 18 x 69	M 12 connector, Type E, F	NO, pnp	▶	3RG40 23-3AB00	122																	
	NC, pnp	▶	3RG40 23-3AA00	122																		
M 18 x 74	M 18 connector, Type P	NO, pnp	▶	3RG40 23-2AB00	122																	
	10	∅ 20 x 62	Un-shielded	Moulded plastic	250 / at AC 230 V 100 / at DC 24 V	2	With terminal compartment for cables 0.5 ... 2.5 mm ²	NO or NC, programmable	▶	3RG46 25-6KD00	122											
		10										M 30 x 54	Shielded	Brass, nickel-pl.	300	2	2 m cable, PUR, 2 x 0.25 mm ²	NO	▶	3RG40 14-0KB00	122	
																	NC	▶	3RG40 14-0KA00	122		
												M 30 x 69					M 12 connector, Type E, F	NO	▶	3RG40 14-3KB00	122	
																	NC	▶	3RG40 14-3KA00	122		
												M 30 x 84					M 18 connector, Type P	NO	▶	3RG40 14-2KB00	122	
																	NC	▶	3RG40 14-2KA00	122		
		M 30 x 54										3	2 m cable, PUR, 3 x 0.25 mm ²	NO, pnp	▶	3RG40 14-0AB00	122					
													NC, pnp	▶	3RG40 14-0AA00	122						
		M 30 x 69											M 12 connector, Type E, F	NO, pnp	▶	3RG40 14-3AB00	122					
												NC, pnp	▶	3RG40 14-3AA00	122							
		M 30 x 84										M 18 connector, Type P	NO, pnp	▶	3RG40 14-2AB00	122						
												NC, pnp	▶	3RG40 14-2AA00	122							
	15	M 30 x 54	Un-shielded	Brass, nickel-pl.	300	2	2 m cable, PUR, 2 x 0.25 mm ²	NO	▶	3RG40 24-0KB00	122											
							NC	▶	3RG40 24-0KA00	122												
		M 30 x 69					M 12 connector, Type E, F	NO	▶	3RG40 24-3KB00	122											
							NC	▶	3RG40 24-3KA00	122												
		M 30 x 84					M 18 connector, Type P	NO	▶	3RG40 24-2KB00	122											
		M 30 x 54					3	2 m cable, PUR, 3 x 0.25 mm ²	NO, pnp	▶	3RG40 24-0AB00	122										
								NC, pnp	▶	3RG40 24-0AA00	122											
		M 30 x 69						M 12 connector, Type E, F	NO, pnp	▶	3RG40 24-3AB00	122										
	NC, pnp	▶	3RG40 24-3AA00	122																		
M 30 x 84	M 18 connector, Type P	NO, pnp	▶	3RG40 24-2AB00	122																	
	NC, pnp	▶	3RG40 24-2AA00	122																		

For comprehensive data and dimension drawings, see Catalogue NS BERO and the Internet: <http://www.siemens.de/bero>.







BERO Proximity Switches

BERO 3RG4 Inductive Proximity Switches

Extra duty

Selection and ordering data

Rated operational voltage AC 20 to 265 V / DC 20 to 320 V • 2-wire • Degree of protection IP 67 (with terminal compartment: IP 65)
 Rated operational voltage DC 10 to 65 V • 3-wire • Degree of protection IP 67 (with terminal compartment: IP 65)

Rated operating distance	Type, dimensions	Embeddable in metal	Enclosure	Rated operational current	Connecting wires	Connection	Switching output function	DT	Order No.	Price	PG
mm	mm			mA					Preferred type		
	15	40 × 40 × 69 (incl. connectors)	Shielded	Moulded plastic	300	2	M 12 connector, Type E, F	NO	▶ 3RG40 38-3KB00		122
	15	40 × 40 × 120	Shielded	Moulded plastic	300	2 ¹⁾	With terminal compartment for cables 0.5 to 2.5 mm ²	NO or NC, programmable	▶ 3RG40 31-6KD00		122
						3	With terminal compartment for cables 0.5 ... 2.5 mm ²	NO or NC, pnp, programmable	▶ 3RG40 31-6AD00		122
	20	40 × 40 × 120	Unshielded	Moulded plastic	300	2 ¹⁾	With terminal compartment for cables 0.5 ... 2.5 mm ²	NO or NC, programmable	▶ 3RG40 41-6KD00		122
						3	With terminal compartment for cables 0.5 ... 2.5 mm ²	NO or NC, pnp, programmable	▶ 3RG40 41-6AD00		122
	20	∅ 34 × 98	Unshielded	Moulded plastic	250 / at AC 230 V 100 / at DC 24 V	2	With terminal compartment for cables 0.5 ... 2.5 mm ²	NO or NC, programmable	▶ 3RG46 26-6KD00		122
	30	60 × 77 × 41	Unshielded	Moulded plastic	300	2 ¹⁾	With terminal compartment for cables 0.5 ... 2.5 mm ²	NO or NC, programmable	▶ 3RG40 42-6KD00		122
						3	With terminal compartment for cables 0.5 ... 2.5 mm ²	NO or NC, pnp, programmable	▶ 3RG40 42-6AD00		122
	40, embeddable 30, non-embeddable	80 × 100 × 42	Shielded/unshielded	Moulded plastic	300	2 ¹⁾	With terminal compartment for cables 0.5 ... 2.5 mm ²	NO or NC, programmable	▶ 3RG40 33-6KD01		122
						3	With terminal compartment for cables 0.5 ... 2.5 mm ²	NO or NC, pnp, programmable	▶ 3RG40 33-6AD01		122
	40	80 × 100 × 42	Unshielded	Moulded plastic	300	2 ¹⁾	With terminal compartment for cables 0.5 ... 2.5 mm ²	NO or NC, programmable	▶ 3RG40 43-6KD00		122
						3	With terminal compartment for cables 0.5 ... 2.5 mm ²	NO or NC, pnp, programmable	▶ 3RG40 43-6AD00		122

For comprehensive data and dimension drawings, see Catalogue NS BERO and the Internet: <http://www.siemens.de/bero>.

1) With only 1 LED.

BERO Proximity Switches

BERO 3RG4 Inductive Proximity Switches

Extreme environment

Selection and ordering data

Rated operational voltage DC 15 to 34 V (3RG46: 10 to 30 V) • 2 or 3-wire • Degree of protection IP 68

	Rated operating distance	Form, dimensions	Embeddable in metal	Enclosure	Rated operational current	Connecting wires	Connection	Switching output function	DT	Order No.	Price	PG
	mm	mm			mA					Preferred type		
	0.6	∅ 4 × 25	Shielded	Stainless steel	200	3	2 m cable, PUR, 3 × 0.14 mm ²	NO, pnp	A	3RG46 00-0AG02		122
	0.6	M 5 × 25	Shielded	Stainless steel	200	3	2 m cable, PUR, 3 × 0.14 mm ²	NO, pnp	A	3RG46 10-0AG02		122
	2.5	∅ 6.5 × 45	Shielded	Brass, nickel-pl.	200	3	2 m cable, PUR, 3 × 0.14 mm ²	NO, pnp	▶	3RG46 02-0AG02		122
	2.5	M 8 × 45	Shielded	Brass, nickel-pl.	200	3	2 m cable, PUR, 3 × 0.14 mm ²	NO, pnp	A	3RG46 11-0AG02		122
	2	∅ 12 × 50	Shielded	Moulded plastic	200	3	2 m cable, PUR, 3 × 0.25 mm ²	NO, pnp	C	3RG40 52-0AG30		122
								NC, pnp	C	3RG40 52-0AF30		122
								NO, npn	C	3RG40 52-0GB30		122
								NC, npn	C	3RG40 52-0GA30		122
	2	M 12 × 50	Shielded	Moulded plastic	200	3	2 m cable, PUR, 3 × 0.25 mm ²	NO, pnp	▶	3RG40 12-0AG30		122
								NC, pnp	C	3RG40 12-0AF30		122
								NO, npn	C	3RG40 12-0GB30		122
								NC, npn	C	3RG40 12-0GA30		122
	2	M 12 × 50	Shielded	Brass	200	3	2 m cable, PVC, 3 × 0.25 mm ²	NO, pnp	C	3RG40 12-0AG31		122
								NO, npn	C	3RG40 12-0GB31		122
4	∅ 12 × 50	Unshielded	Moulded plastic	200	3	2 m cable, PUR, 3 × 0.25 mm ²	NO, pnp	C	3RG40 62-0AG30		122	
							NC, pnp	C	3RG40 62-0AF30		122	
							NO, npn	▶	3RG40 62-0GB30		122	
							NC, npn	C	3RG40 62-0GA30		122	
4	M 12 × 50	Unshielded	Moulded plastic	200	3	2 m cable, PUR, 3 × 0.25 mm ²	NO, pnp	C	3RG40 22-0AG30		122	
							NC, pnp	C	3RG40 22-0AF30		122	
							NO, npn	▶	3RG40 22-0GB30		122	
							NC, npn	C	3RG40 22-0GA30		122	
4	M 12 × 56	Unshielded	Brass	200	3	2 m cable, PVC, 3 × 0.25 mm ²	NO, pnp	C	3RG40 22-0AG31		122	
							NO, npn	C	3RG40 22-0GB31		122	
4	M 12 × 56	Unshielded	Moulded plastic	200	2	2 m cable, PVC, 2 × 0.25 mm ²	AC/DC	NO	▶	3RG40 22-0KB30		122
4	M 12 × 56	Unshielded	Moulded plastic	300	3	2 m cable, PUR, 3 × 0.25 mm ²	DC 65 V	NO, pnp	▶	3RG40 22-0AB30		122
5	∅ 18 × 54	Shielded	Moulded plastic	200	3	2 m cable, PUR, 3 × 0.25 mm ²	NO, pnp	C	3RG40 53-0AG30		122	
							NC, pnp	C	3RG40 53-0AF30		122	
							NO, npn	C	3RG40 53-0GB30		122	
							NC, npn	C	3RG40 53-0GA30		122	
5	M 18 × 54	Shielded	Moulded plastic	200	3	2 m cable, PUR, 3 × 0.25 mm ²	NO, pnp	C	3RG40 13-0AG30		122	
							NC, pnp	C	3RG40 13-0AF30		122	
							NO, npn	C	3RG40 13-0GB30		122	
							NC, npn	C	3RG40 13-0GA30		122	
5	M 18 × 54	Shielded	Brass	200	3	2 m cable, PVC, 3 × 0.25 mm ²	NO, pnp	C	3RG40 13-0AG31		122	
							NO, npn	C	3RG40 13-0GB31		122	

For comprehensive data and dimension drawings, see Catalogue NS BERO and the Internet: <http://www.siemens.de/bero>.

BERO Proximity Switches

BERO 3RG4 Inductive Proximity Switches

Extreme environment

Selection and ordering data

Rated operational voltage DC 15 to 34 V • 2, 3 or 4-wire • Degree of protection IP 68

Rated operating distance	Form, dimensions	Embeddable in metal	Enclosure	Rated operational current	Connecting wires	Connection	Switching output function	DT	Order No.	Price	PG
mm	mm			mA					Preferred type		
8	Ø 18 × 54	Unshielded	Moulded plastic	200	3	2 m cable, PUR, 3 × 0.25 mm ²	NO, pnp	C	3RG40 63-0AG30	122	
							NC, pnp	C	3RG40 63-0AF30	122	
							NO, npn	C	3RG40 63-0GB30	122	
							NC, npn	C	3RG40 63-0GA30	122	
8	M 18 × 54	Unshielded	Moulded plastic	200	3	2 m cable, PUR, 3 × 0.25 mm ²	NO, pnp	C	3RG40 23-0AG30	122	
							NC, pnp	C	3RG40 23-0AF30	122	
							NO, npn	C	3RG40 23-0GB30	122	
							NC, npn	C	3RG40 23-0GA30	122	
8	M 18 × 54	Unshielded	Brass	200	3	2 m cable, PVC, 3 × 0.25 mm ²	NO, pnp	C	3RG40 23-0AG31	122	
							NO, npn	C	3RG40 23-0GB31	122	
8	M 18 × 54	Unshielded	Moulded plastic	300	2 AC/DC	2 m cable, PVC, 2 × 0.25 mm ²	NO	▶	3RG40 23-0KB30	122	
							3 DC 65 V	NO, pnp	C	3RG40 23-0AB30	
10	Ø 30 × 54	Shielded	Moulded plastic	200	3	2 m cable, PUR, 3 × 0.25 mm ²	NO, pnp	C	3RG40 54-0AG30	122	
							NC, pnp	C	3RG40 54-0AF30	122	
							NO, npn	C	3RG40 54-0GB30	122	
							NC, npn	C	3RG40 54-0GA30	122	
10	M 30 × 54	Shielded	Moulded plastic	200	3	2 m cable, PUR, 3 × 0.25 mm ²	NO, pnp	C	3RG40 14-0AG30	122	
							NC, pnp	C	3RG40 14-0AF30	122	
							NO, npn	C	3RG40 14-0GB30	122	
							NC, npn	C	3RG40 14-0GA30	122	
10	M 30 × 54	Shielded	Brass	200	3	2 m cable, PVC, 3 × 0.25 mm ²	NO, pnp	C	3RG40 14-0AG31	122	
							NO, npn	C	3RG40 14-0GB31	122	
15	Ø 30 × 54	Unshielded	Moulded plastic	200	3	2 m cable, PUR, 3 × 0.25 mm ²	NO, pnp	C	3RG40 64-0AG30	122	
							NC, pnp	C	3RG40 64-0AF30	122	
							NO, npn	C	3RG40 64-0GB30	122	
							NC, npn	C	3RG40 64-0GA30	122	
15	M 30 × 54	Unshielded	Moulded plastic	200	3	2 m cable, PUR, 3 × 0.25 mm ²	NO, pnp	A	3RG40 24-0AG30	122	
							NC, pnp	C	3RG40 24-0AF30	122	
							NO, npn	C	3RG40 24-0GB30	122	
							NC, npn	C	3RG40 24-0GA30	122	
15	M 30 × 54	Unshielded	Brass	200	3	2 m cable, PVC, 3 × 0.25 mm ²	NO, pnp	C	3RG40 24-0AG31	122	
							NO, npn	C	3RG40 24-0GB31	122	
15	M 30 × 54	Unshielded	Moulded plastic	300	2 AC/DC	2 m cable, PVC, 2 × 0.25 mm ²	NO	▶	3RG40 24-0KB30	122	
							3 DC 65 V	NO, pnp	C	3RG40 24-0AB30	
15	40 × 40 × 112	Shielded	Moulded plastic	200	4	2 m cable, PUR, 4 × 0.14 mm ²	NO + NC, pnp	C	3RG40 30-0CD00	97.70	122
							NO + NC, pnp	C	3RG40 30-0CD01	97.70	122
15	40 × 40 × 112	Shielded	Moulded plastic	300	2 AC/DC	2 m cable, PUR, 2 × 0.25 mm ²	NO	C	3RG40 30-0KB00	200.—	122
							NC	C	3RG40 30-0KA00	200.—	122
							NO	C	3RG40 30-0KB01	200.—	122
							NC	C	3RG40 30-0KA01	200.—	122
							NO, pnp	C	3RG40 30-0AB00	84.40	122
							NC, pnp	C	3RG40 30-0AA00	84.40	122
				300	3 DC 65 V	2 m cable, PUR, 3 × 0.25 mm ²	NO, pnp	C	3RG40 30-0AB01	84.40	122

For comprehensive data and dimension drawings, see Catalogue NS BERO and the Internet: <http://www.siemens.de/bero>.

BERO Proximity Switches

BERO 3RG4 Inductive Proximity Switches

Greater rated operating distance

Selection and ordering data

Rated operational voltage DC 15 to 34 V (3RG46: 10 to 30 V) • 3-wire • Degree of protection IP 67

Rated operating distance	Form, dimensions	Embeddable in metal	Enclosure	Rated operational current	Connecting wires	Connection	Switching output function	DT	Order No.	Price	PG	
mm	mm			mA					Preferred type			
2	M 8 × 35	Shielded	Stainless steel	200	3	2 m cable, PUR, 3 × 0.25 mm ²	NO, pnp	▶	3RG41 11-0AG33	122		
							NC, pnp	▶	3RG41 11-0AF33	122		
							NO, npn	C	3RG41 11-0GB33	122		
							NC, npn	C	3RG41 11-0GA33	122		
	M 8 × 45						8 mm combined plug, Type A	NO, pnp	▶	3RG41 11-7AG33	122	
								NC, pnp	▶	3RG41 11-7AF33	122	
								NO, npn	C	3RG41 11-7GB33	122	
								NC, npn	C	3RG41 11-7GA33	122	
2	M 8 × 50	Shielded	Stainless steel	200	3	3 m cable, PUR, 3 × 0.25 mm ²	NO, pnp	▶	3RG41 11-0AG00	122		
	M 8 × 55							NO, pnp	▶	3RG41 11-3AG00	122	
	M 8 × 60							NO, pnp	▶	3RG41 11-3AG22	122	
3	Ø 6.5 × 45	Semi-shielded	Brass, nickel-pl.	200	3	2 m cable, PUR, 3 × 0.25 mm ²	NO, pnp	▶	3RG46 02-1AB00	122		
							NO, npn	A	3RG46 02-1GB01	122		
	Ø 6.5 × 60							NO, pnp	▶	3RG46 02-7AG01	122	
3	8 × 8 × 40	Semi-shielded	Brass, nickel-pl.	200	3	2 m cable, PUR, 3 × 0.14 mm ²	NO, pnp	▶	3RG46 37-0AG01	122		
							NO, npn	A	3RG46 37-0GB01	122		
	8 × 8 × 59							NO, pnp	▶	3RG46 37-7AG01	122	
						8 mm combined plug, Type A	NO, npn	A	3RG46 37-7GB01	122		
3	M 8 × 45	Semi-shielded	Brass, nickel-pl.	200	3	2 m cable, PUR, 3 × 0.25 mm ²	NO, pnp	▶	3RG46 11-0AG01	122		
							NO, npn	A	3RG46 11-0GB01	122		
	M 8 × 53							NO, pnp	▶	3RG46 11-7AG01	122	
	M 8 × 66							NO, pnp	A	3RG46 11-3AG01	122	
						M 12 connector, Type E, F	NO, npn	A	3RG46 11-3GB01	122		
4	M 12 × 35	Shielded	Brass, nickel-pl.	200	3	2 m cable, PUR, 3 × 0.25 mm ²	NO, pnp	C	3RG41 12-0AG33	122		
	M 12 × 45							NO, pnp	C	3RG41 12-3AG33	122	
4	M 12 × 50	Shielded	Brass, nickel-pl.	200	3	2 m cable, PUR, 3 × 0.25 mm ²	NO, pnp	▶	3RG41 12-0AG01	122		
							NC, pnp	▶	3RG41 12-0AF01	122		
	M 12 × 59							NO, pnp	▶	3RG41 12-3AG01	122	
									NC, pnp	C	3RG41 12-3AF01	122
						M 12 connector, Type E, F						

For comprehensive data and dimension drawings, see Catalogue NS BERO and the Internet: <http://www.siemens.de/bero>.

BERO Proximity Switches

BERO 3RG4 Inductive Proximity Switches

Greater rated operating distance

Selection and ordering data

Rated operational voltage DC 15 to 34 V (3RG46: 10 to 30 V) • 3-wire • Degree of protection IP 67

	Rated operating distance	Form, dimensions	Embeddable in metal	Enclosure	Rated operational current	Connecting wires	Connection	Switching output function	DT	Order No.	Price	PG
	mm	mm			mA					▶ Preferred type		
	6	M 8 × 41	Unshielded	Brass, nickel-pl.	200	3	2 m cable, PUR, 3 × 0.25 mm ²	NO, pnp NO, npn	▶ A	3RG46 21-0AG02 3RG46 21-0GB02	122	122
		M 8 × 60					8 mm combined plug, Type A	NO, pnp NO, npn	▶ A	3RG46 21-7AG02 3RG46 21-7GB02	122	122
		M 8 × 62					M 12 connector, Type E, F	NO, pnp NO, npn	A A	3RG46 21-3AG02 3RG46 21-3GB02	122	122
	6	M 12 × 50	Semi-shielded	Brass, nickel-pl.	200	3	2 m cable, PUR, 3 × 0.34 mm ²	NO, pnp NO, npn	▶ A	3RG46 12-0AG01 3RG46 12-0GB01	122	122
		M 12 × 60					M 12 connector, Type E, F	NO, pnp NO, npn	▶ A	3RG46 12-3AB01 3RG46 12-3GB01	122	122
	8	M 18 × 35	Semi-shielded	Brass, nickel-pl.	200	3	2 m cable, PUR, 3 × 0.25 mm ²	NO, pnp	C	3RG41 13-0AG33	122	
		M 18 × 45					M 12 connector, Type E, F	NO, pnp	C	3RG41 13-3AG33	122	
	8	M 18 × 70	Semi-shielded	Brass, nickel-pl.	200	3	2 m cable, PUR, 3 × 0.25 mm ²	NO, pnp	C	3RG41 13-0AG01	122	
							M 12 connector, Type E, F	NO, pnp	C	3RG41 13-3AG01	122	
	10	M 12 × 50	Unshielded	Brass, nickel-pl.	200	3	2 m cable, PUR, 3 × 0.34 mm ²	NO, pnp	▶	3RG46 22-0AG02	122	
		M 12 × 60					M 12 connector, Type E, F	NO, pnp	▶	3RG46 22-3AB03	122	
12	M 18 × 50	Semi-shielded	Brass	200	3	2 m cable, PUR, 3 × 0.34 mm ²	NO, pnp NO, npn	A A	3RG46 13-1AB01 3RG46 13-0GB00	122	122	
						M 12 connector, Type E, F	NO, pnp NO, npn	A A	3RG46 13-3AB01 3RG46 13-3GB01	122	122	
	M 18 × 63.5											
15	M 30 × 70	Shielded	Brass, nickel-pl.	200	3	2 m cable, PUR, 3 × 0.25 mm ²	NO, pnp	C	3RG41 14-0AG01	122		
						M 12 connector, Type E, F	NO, pnp	C	3RG41 14-3AG01	122		
20	M 18 × 50	Unshielded	Brass	200	3	2 m cable, PUR, 3 × 0.34 mm ²	NO, pnp NO, npn	A A	3RG46 23-0AB02 3RG46 23-0GB02	122	122	
	M 18 × 63.5					M 12 connector, Type E, F	NO, pnp NO, npn	▶ A	3RG46 23-3AB02 3RG46 23-3GB02	122	122	
22	M 30 × 60	Semi-shielded	Brass	200	3	2 m cable, PUR, 3 × 0.34 mm ²	NO, pnp NO, npn	A A	3RG46 14-0AB00 3RG46 14-0GB00	122	122	
	M 30 × 73.5					M 12 connector, Type E, F	NO, pnp NO, npn	A A	3RG46 14-3AB00 3RG46 14-3GB00	122	122	
40	M 30 × 60	Unshielded	Brass	200	3	2 m cable, PUR, 3 × 0.34 mm ²	NO, pnp NO, npn	A A	3RG46 24-0AB02 3RG46 24-0GB02	122	122	
	M 30 × 74					M 12 connector, Type E, F	NO, pnp NO, npn	▶ A	3RG46 24-3AB02 3RG46 24-3GB02	122	122	

For comprehensive data and dimension drawings, see Catalogue NS BERO and the Internet: <http://www.siemens.de/bero>.

BERO Proximity Switches

BERO 3RG4 Inductive Proximity Switches





Greater rated operating distance

Selection and ordering data

Rated operational voltage DC 15 to 34 V (3RG46: 10 to 30 V) • 3 or 4-wire • Degree of protection IP 67
(with terminal compartment: IP 65)

Rated operational voltage AC 20 to 265 V / DC 20 to 320 V • 2-wire • Degree of protection of IP 67

Rated operational voltage DC 10 to 65 V • 3-wire • Degree of protection IP 67 (with terminal compartment: IP 65)

	Rated operating distance	Form, dimensions	Embeddable in metal	Enclosure	Rated operational current	Connecting wires	Connection	Switching output function	DT	Order No.	Price	PG
	mm	mm			mA					▶ Preferred type		
	20	40 × 40 × 65 (incl. connectors)	Shielded	Moulded plastic	200	3	M 12 connector, Type E, F	NO, pnp NO, npn	A A	3RG46 38-3AG01 3RG46 38-3GB01		122
	20	40 × 40 × 69 (incl. connectors)	Shielded	Moulded plastic	200	2 AC/DC	M 12 connector, Type E, F	NO	▶	3RG41 38-3KB00		122
					200	4	M 12 connector, Type F	NO + NC, pnp NO + NC, npn	▶ A	3RG41 38-3CD00 3RG41 38-3GD00		122
	35	40 × 40 × 69 (incl. connectors)	Unshielded	Moulded plastic	300	2 AC/DC	M 12 connector, Type E, F	NO	▶	3RG41 48-3KB00		122
				200	4	M 12 connector, Type F	NO + NC, pnp NO + NC, npn	▶ A	3RG41 48-3CD00 3RG41 48-3GD00		122	
	20	40 × 40 × 118	Shielded	Moulded plastic	200	4	With terminal compartment for cables 0.5 ... 2.5 mm ²	NO + NC, pnp	C	3RG41 34-6CD01		122
	30	40 × 40 × 118	Unshielded	Moulded plastic	200	4	With terminal compartment for cables 0.5 ... 2.5 mm ²	NO + NC, pnp	C	3RG41 44-6CD01		122
	25	40 × 40 × 120	Semi-flush	Moulded plastic	300	3 DC 65 V	With terminal compartment for cables 0.5 ... 2.5 mm ²	NO or NC, pnp, programmable NO or NC, npn, programmable	▶ C	3RG41 31-6AD00 3RG41 31-6AD04		122
	40	40 × 40 × 120	Unshielded	Moulded plastic	300	3 DC 65 V	With terminal compartment for cables 0.5 ... 2.5 mm ²	NO, pnp NO or NC, pnp, programmable NO or NC, npn, programmable	C ▶ C	3RG41 41-6AB03 3RG41 41-6AD00 3RG41 41-6AD04		122
25 / 40, switchable	40 × 40 × 132 (incl. connectors)	Unshielded	Moulded plastic	300	3 DC 65 V	M 12 connector, Type E, F	NO, pnp	C	3RG41 41-3AB02		122	
25 / 40, switchable	40 × 40 × 149 (incl. connectors)	Unshielded	Moulded plastic	300	3 DC 65 V	M 12 connector, Type E, F, movable in 30° steps	NO, pnp	C	3RG41 41-3AB01		122	
	50	60 × 77 × 41	Unshielded	Moulded plastic	300	3 DC 65 V	With terminal compartment for cables 0.5 ... 2.5 mm ²	NO or NC, pnp, programmable	C	3RG41 42-6AD00		122
	65	80 × 100 × 42	Unshielded	Moulded plastic	300	3 DC 65 V	With terminal compartment for cables 0.5 ... 2.5 mm ²	NO or NC, pnp, programmable	C	3RG41 43-6AD00		122

For comprehensive data and dimension drawings, see Catalogue NS BERO and the Internet: <http://www.siemens.de/bero>.





BERO Proximity Switches

BERO 3RG4 Inductive Proximity Switches

No reduction factor

Selection and ordering data

Rated operational voltage 10 to 30 V DC • 3-wire • Degree of protection IP 67

	Rated operating distance	Form, dimensions	Embeddable in metal	Rated operational current	Enclosure	Connection	Switching output function	DT	Order No.	Price	PG				
	mm	mm		mA					Preferred type						
	1.5	M 8 × 42	Shielded	150	Stainless steel	2 m cable, PUJ, 3 × 0.25 mm ²	NO, pnp	A	3RG46 11-0AN01		122				
		M 8 × 49.6				8 mm combined plug, Type A	NO, pnp	A	3RG46 11-7AN01		122				
		M 8 × 57.4				M 12 connector, Type E, F	NO, pnp	A	3RG46 11-3AN01		122				
		4	M 8 × 41.6	Unshielded	150	Stainless steel	2 m cable, PUJ, 3 × 0.25 mm ²	NO, pnp	A	3RG46 21-0AN01		122			
		M 8 × 49.2				8 mm combined plug, Type A	NO, pnp	A	3RG46 21-7AN01		122				
		M 8 × 57				M 12 connector, Type E, F	NO, pnp	A	3RG46 21-3AN01		122				
		3	M 12 × 50.4	Shielded	200	Brass, chrome-plated	2 m cable, PUJ, 3 × 0.34 mm ²	NO, pnp	A	3RG46 12-0AN01		122			
		M 12 × 52				M 12 connector, Type E, F	NO, pnp	A	3RG46 12-3AN01		122				
		M 12 × 50.4				M 12 connector, Type E, F	NO, pnp	A	3RG46 12-3AN05		122				
		M 12 × 50.4			Stainless steel	2 m cable, PUJ, 3 × 0.34 mm ²	NO, pnp	A	3RG46 12-0AN61		122				
	M 12 × 52				M 12 connector, Type E, F	NO, pnp	A	3RG46 12-3AN61		122					
	8	M 12 × 55	Unshielded	200	Brass, chrome-plated	2 m cable, PUJ, 3 × 0.34 mm ²	NO, pnp	A	3RG46 22-0AN01		122				
		M 12 × 51				M 12 connector, Type E, F	NO, pnp	A	3RG46 22-3AN01		122				
		M 12 × 55				M 12 connector, Type E, F	NO, pnp	A	3RG46 22-3AN05		122				
		M 12 × 55			Stainless steel	2 m cable, PUJ, 3 × 0.34 mm ²	NO, pnp	A	3RG46 22-0AN61		122				
	M 12 × 51				M 12 connector, Type E, F	NO, pnp	A	3RG46 22-3AN61		122					
	5	M 18 × 54	Shielded	200	Brass, chrome-plated	2 m cable, PUJ, 3 × 0.34 mm ²	NO, pnp	A	3RG46 13-0AN01		122				
		M 18 × 53				M 12 connector, Type E, F	NO, pnp	A	3RG46 13-3AN01		122				
		M 18 × 54				M 12 connector, Type E, F	NO, pnp	A	3RG46 13-3AN05		122				
		M 18 × 54			Stainless steel	2 m cable, PUJ, 3 × 0.34 mm ²	NO, pnp	A	3RG46 13-0AN61		122				
	M 18 × 53				M 12 connector, Type E, F	NO, pnp	A	3RG46 13-3AN61		122					
	12	M 18 × 54	Unshielded	200	Brass, chrome-plated	2 m cable, PUJ, 3 × 0.34 mm ²	NO, pnp	A	3RG46 23-0AN01		122				
		M 18 × 53				M 12 connector, Type E, F	NO, pnp	A	3RG46 23-3AN01		122				
		M 18 × 54				M 12 connector, Type E, F	NO, pnp	A	3RG46 23-3AN05		122				
		M 18 × 54			Stainless steel	2 m cable, PUJ, 3 × 0.34 mm ²	NO, pnp	A	3RG46 23-0AN61		122				
	M 18 × 53				M 12 connector, Type E, F	NO, pnp	A	3RG46 23-3AN61		122					

For comprehensive data and dimension drawings, see Catalogue NS BERO and the Internet: <http://www.siemens.de/bero>.









BERO Proximity Switches

BERO 3RG4 Inductive Proximity Switches

No reduction factor

Selection and ordering data

Rated operational voltage 10 to 30 V DC • 3-wire • Degree of protection IP 67 (with terminal compartment: IP 65)

	Rated operating distance	Form, dimensions	Embeddable in metal	Rated operational current	Enclosure	Connection	Switching output function	DT	Order No.	Price	PG
	mm	mm		mA							
	10	M 30 × 64	Shielded	200	Brass, chrome-plated	2 m cable, PUR, 3 × 0.34 mm ²	NO, pnp	A	3RG46 14-0AN01		122
		M 30 × 63				M 12 connector, Type E, F	NO, npn	A	3RG46 14-0GN01		122
	M 30 × 64	Brass, Teflon-coated	M 12 connector, Type E, F	NO, pnp	A	3RG46 14-3AN01		122			
			NO, npn	A	3RG46 14-3GN01		122				
		Stainless steel	2 m cable, PUR, 3 × 0.34 mm ²	NO, pnp	A	3RG46 14-0AN61		122			
			NO, npn	A	3RG46 14-0GN61		122				
M 30 × 63		M 12 connector, Type E, F	NO, pnp	A	3RG46 14-3AN61		122				
		NO, npn	A	3RG46 14-3GN61		122					
	20	M 30 × 64	Unshielded	200	Brass, chrome-plated	2 m cable, PUR, 3 × 0.34 mm ²	NO, pnp	A	3RG46 24-0AN01		122
		M 30 × 63				M 12 connector, Type E, F	NO, npn	A	3RG46 24-0GN01		122
	M 30 × 64	Brass, Teflon-coated	M 12 connector, Type E, F	NO, pnp	A	3RG46 24-3AN01		122			
			NO, npn	A	3RG46 24-3GN01		122				
		Stainless steel	2 m cable, PUR, 3 × 0.34 mm ²	NO, pnp	A	3RG46 24-0AN61		122			
			NO, npn	A	3RG46 24-0GN61		122				
M 30 × 63		M 12 connector, Type E, F	NO, pnp	A	3RG46 24-3AN61		122				
		NO, npn	A	3RG46 24-3GN61		122					
	15	40 × 40 × 65 (incl. connectors)	Shielded	200	Moulded plastic	M 12 connector, Type E, F	NO, pnp	A	3RG46 38-3AN01		122
							NO, npn	A	3RG46 38-3GN01		122
	25	40 × 40 × 65 (incl. connectors)	Unshielded	200	Moulded plastic	M 12 connector, Type E, F	NO, pnp	A	3RG46 48-3AN01		122
							NO, npn	A	3RG46 48-3GN01		122
	35	40 × 40 × 65 (incl. connectors)	Unshielded	250	Moulded plastic	M 12 connector, Type E, F	NO, pnp	A	3RG46 48-3AN11		122
							NO, npn	A	3RG46 48-3GN11		122
	15	40 × 40 × 114	Shielded	200	Moulded plastic	With terminal compartment for cables 0.5 ... 2.5 mm ²	NO, pnp	A	3RG46 34-6AN01		122
							NO, npn	A	3RG46 34-6GN01		122
	25	40 × 40 × 114	Unshielded	150	Moulded plastic	With terminal compartment for cables 0.5 ... 2.5 mm ²	NO, pnp	A	3RG46 44-6AN02		122
							NO, npn	A	3RG46 44-6GN02		122
	40	40 × 40 × 114	Unshielded	200	Moulded plastic	With terminal compartment for cables 0.5 ... 2.5 mm ²	NO, pnp	A	3RG46 44-6AN01		122
							NO, npn	A	3RG46 44-6GN01		122
	75	80 × 80 × 40.5	Unshielded	200	Moulded plastic	With terminal compartment for cables 0.5 ... 2.5 mm ²	NO, pnp	A	3RG46 43-6AN01		122
							NO, npn	A	3RG46 43-6GN01		122

For comprehensive data and dimension drawings, see Catalogue NS BERO and the Internet: <http://www.siemens.de/bero>.





BERO Proximity Switches

BERO 3RG4 Inductive Proximity Switches

Special designs

Selection and ordering data

Rated operational voltage DC 10 to 30 V • 2, 3 or 4-wire • Degree of protection IP 67 (DESINA IP 68)

Rated operating distance	Form, dimensions	Embeddable in metal	Enclosure	Rated operational current	Connecting wires	Connection	Switching element function/ analogue output	DT	Order No.	Price	PG	
mm	mm			mA								
Pressure-resistant up to 500 bar (7250 psi)												
	3	Ø 12 × 56.5 M 14 thread	Semi-shielded	Stainless steel	200	3	2 m cable, PUR, 3 × 0.34 mm ²	NO, pnp NC, pnp	A	3RG46 52-0PG00	122	
				Aluminium-oxide ceramic sensing face				NO, npn NC, npn	A	3RG46 52-0PB00 3RG46 52-0PA00	122 122	
		Ø 12 × 65 M 14 thread					M 12 connector, Type E, F	NO, pnp NC, pnp NO, npn NC, npn	A C A A	3RG46 52-3PG00 3RG46 52-3PF00 3RG46 52-3PB00 3RG46 52-3PA00	122 122 122 122	
	With analogue output											
		0 ... 6	M 12 × 50 M 12 × 60	Semi-shielded	Brass	10	4	2 m cable, PUR, 4 × 0.25 mm ²	0 ... 5 V, 1 ... 5 mA	A	3RG46 12-0NB00	122
								M 12 connector, Type F	0 ... 5 V, 1 ... 5 mA	A	3RG46 12-3NB00	122
Optimized for DESINA												
	2	M 12 × 69 M 12 × 66	Shielded	Stainless steel	200, 50 diagnostic	2 + 1 3 + 1	M 12 connector, Type F	NO + diagnostic	X	3RG46 12-3JR00	122	
				Stainless steel			M 12 connector, Type F	NO + diagnostic, pnp	X	3RG46 12-3AR00	122	
	4	M 12 × 69	Shielded	Stainless steel	200, 10 diagnostic	2 + 1	M 12 connector, Type F	NO + diagnostic	X	3RG46 12-3JR01	122	
For connection to AS-Interface												
	5	M 18 × 80	Shielded	Moulded plastic	–	2	M 12 connector, Type E, F		A	3RG46 13-3WS00	122	
		10	M 30 × 78	Shielded	Moulded plastic	–	2	M 12 connector, Type E, F		A	3RG46 14-3WS00	122
		15	40 × 40 × 66.5	Shielded	Moulded plastic	–	2	M 12 connector, Type E, F		A	3RG46 38-3WS00	122

For comprehensive data and dimension drawings, see Catalogue NS BERO and the Internet: <http://www.siemens.de/bero>.

BERO Proximity Switches

BERO 3RG4 Inductive Proximity Switches

According to NAMUR (non-self contained)

Selection and ordering data

Rated operational voltage DC 5 to 25 V • 2-wire • Degree of protection IP 67

	Rated operating distance	Form, dimensions	Embeddable in metal	Enclosure	Connection	DT	Order No.	Price	PG
	mm	mm					Preferred type		
	0.8	∅ 4.5 × 20	Shielded	Stainless steel	2 m cable, LiYY, 2 × 0.14 mm ²	A	3RG46 04-1NA00		122
	1.5	M 8 × 22	Shielded	Stainless steel	2 m cable, LiYY, 2 × 0.14 mm ²	A	3RG46 11-1NA00		122
	2	M 12 × 35	Shielded	Stainless steel	2 m cable, LiYY, 2 × 0.34 mm ²	A	3RG46 12-1NA00		122
	4	M 12 × 35	Unshielded	Moulded plastic	2 m cable, LiYY, 2 × 0.34 mm ²	A	3RG46 22-1NA00		122
	5	M 18 × 40	Shielded	Stainless steel	2 m cable, LiYY, 2 × 0.34 mm ²	A	3RG46 13-1NA00		122
	8	M 18 × 40	Unshielded	Moulded plastic	2 m cable, LiYY, 2 × 0.34 mm ²	A	3RG46 23-1NA00		122
	10	M 30 × 40	Shielded	Stainless steel	2 m cable, LiYY, 2 × 0.75 mm ²	A	3RG46 14-1NA00		122
	15	M 30 × 40	Unshielded	Moulded plastic	2 m cable, LiYY, 2 × 0.75 mm ²	A	3RG46 24-1NA00		122
	15	40 × 40 × 118	Shielded	Moulded plastic	With terminal compartment for cables 0.5 ... 2.5 mm ²	A	3RG46 31-6NA00		122

Evaluation devices • for snapping onto 35 mm mounting rail • degree of protection IP 20

	Dimensions (W × H × D)	Operating voltage range	Outputs	Outputs: Rated currents (short-circuit proof)	DT	Order No.	Price	PG
	mm	V		mA				
	20 × 92.5 × 110	10 ... 30	2 electronic outputs (NO or NC adjustable)	Output 1: 10 mA, Output 2: 100 mA	A	3RX1 730		122
		20.4 ... 27.6	1 relay output (changeover)	AC 250 V: 2 A, p.f. = 0.7 DC 30 V: 2 A	A	3RX1 731		122

For comprehensive data and dimension drawings, see Catalogue NS BERO and the Internet: <http://www.siemens.de/bero>.