



# Compax 1000SL

compact servo controller

Catalogue 1600.271.01/UK  
September, 2000



## A new member of the acclaimed COMPAX family from Parker...

Introducing the COMPAX 1000SL, the latest addition to the range of Compax digital servo controllers from Parker's Electromechanical Division. Existing Compax drives span a power range from 2.5kVA to 35kVA; this new model extends the lower boundary down to 1kVA. With its extremely compact housing and competitive price, the Compax 1000SL offers the opportunity to utilise fully-digital servo technology in an even wider range of applications.

### The Compax philosophy

In the case of traditional automation solutions, multiple operations are frequently derived from a common shaft by means of mechanical components. The requirement for more flexible and cost-effective machines then becomes increasingly difficult to satisfy. Electronic servo controls offer a decentralised solution to this problem, and the replacement of inflexible mechanical components such as gears, shafts and cams by individual electronically-controlled drives leads to greater functional capability. Compax is specifically designed to meet this challenge with a range of powerful, application-specific firmware options.

### Outstanding functional capability

In addition to straightforward automation tasks, Compax is able to perform complex and specialised functions such as dynamic interlinking of cam profiles and precise axis synchronisation. Using the HEDA real-time bus, several Compax axes may be synchronised to within 2.5µs; in practice, this means that positional synchronisation within 1 arc-minute is achievable at speeds up to 3000 rpm. This performance is combined with a high degree of system integration using all common field buses.

### Exceptionally compact housing

The compact 1000SL package incorporates not only the power stage, control electronics and integral position controller but also a direct-on-line power supply. This means it may be connected directly to single-phase AC supplies with rated voltages up to 230V. An independent +24V supply is used for the control electronics, allowing communication to be maintained under emergency stop conditions. The low installed volume makes the unit particularly suitable for incorporation within the installation or machine.

### Optimum price-performance ratio

An application-specific ASIC, which integrates most of the electronic functions, provides a flexible and extremely powerful hardware platform. This cost-effective approach, used as the basis of all Compax drives, ensures that the 1000SL represents exceptional value as a high-performance servo system. Combined with Parker's competitively-priced servo motors, the whole package provides power and performance to meet the needs of the most demanding applications.



### COMPAX 1000SL features

- Power supply 230V AC single phase, control voltage 24V DC
- Output rating 1kVA continuous
- Operates with synchronous motors up to 9000 rpm
- Control of motor brake
- External ballast resistor
- 8 digital inputs, 8 digital outputs
- Analogue override input
- Resolver or SinCos® high-resolution sensor
- RS232 communication standard
- Step-direction input
- Encoder interface
- HEDA real time bus
- Fieldbus interface options:
 

RS485	CANopen
Profibus	Interbus-S
CAN-Bus	CS31
- Software variants:
  - Standard
  - Rotary table control
  - Electronic gearbox
  - Cam profile generation

## Output data

- Continuous rated current: 2.5A RMS
- Peak current: 5A RMS (5 secs max. duration)
- Rated power: 1kVA
- Short circuit/ground fault-resistant IGBT final stage

## Power supply

- Mains supply: 230V AC single-phase
- Control voltage: 24V DC

## Positioning performance

- Resolution at the motor shaft: 16 bit (= 0.3 arc-minutes)
- Absolute accuracy: +/-15 arc-minutes.

## Regeneration mode

- Bus capacitance: 660µF
- Storable energy: 17Ws
- Ballast resistor: external

## Command memory

- 250 commands, power failure protected

## Set point generator

- Ramps: linear, quadratic or jerk free; 10ms - 60s
- Travel distance programmable in increments, mm, inches or variable using a scaling factor

## Monitoring functions

- Power & control voltage range
- Motor final stage temperature/stall protection
- Position error
- 'Ready' contact: 0.5A, 60V, 30W

## Parameter input/status request

- Via RS232 and fieldbus.
- Via Compax hand-held terminal

## Inputs & outputs

- 8 digital inputs, 8 digital outputs, 24V levels
- Step-direction, enable & emergency stop inputs
- Override input (0V - 5V)

## RS232 communication

- 9600 Baud, 8 bit word length, 1 start bit, 1 stop bit
- Software handshake (XON - XOFF) supported

## Encoder interface (optional)

- Encoder input & simulation (alternative to the step-direction input)

## High resolution sensor (option S1/S2)

- SinCos® high-resolution sensor in lieu of resolver
- Single or multiturn (absolute to 4096 motor revolutions)
- Option S2 with multiturn: absolute value sensor with programmable reset path

## Fieldbus interfaces

- Optically-isolated bus connection
- RS485, Interbus-S, Profibus, CS31, CAN-Bus, CANopen
- HEDA (synchronous serial interface)

## ServoManager software aid

- Routine axis management (reading, editing, printing and archiving parameters and programs)
- Guided configuration
- Guided parameter setting
- Fault tracking and fault history
- Management of variables
- Direct terminal access to Compax
- Management of cam profile data (CamEditor)

## Housing

- Enclosed metal housing, insulation VDE0160/Class IP20

## CE conformity

- EMC immunity/emission according to EN61800-3
- Safety to VDE 0160/EN 50178

## Ambient conditions

- Temperature range: 0° - 45°C.
- Max. relative humidity according to DIN 40040 class F (up to 75%, non-condensing)

## Dimensions & weight (see diagram below)

- Unit depth without mating connectors 146mm
- Installed depth with mating connectors 183mm
- Panel mounting, suitable for installation in industrial equipment cabinets, secured by 3 x M4 screws
- Weight approx. 2kg

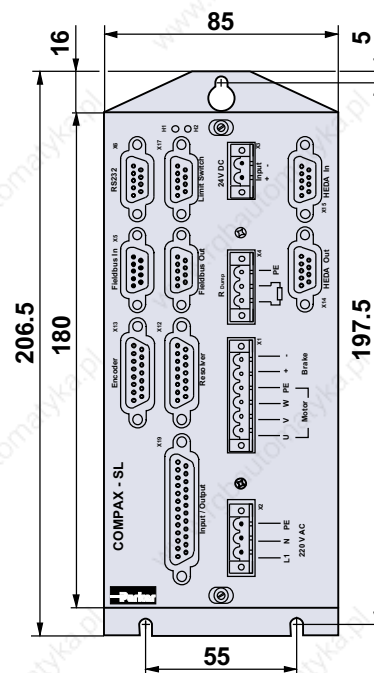



## HDY Series servo motors

Parker offers a choice of three high-performance brushless servo motors for use with the Compax 1000SL. They provide excellent dynamic performance in a cost-effective package, and with the available options they may be tailored to a wide range of applications.

HDY motors are three-phase designs using high-energy Samarium Cobalt magnets in a low-inertia rotor. They allow high acceleration currents to be used for rapid positioning, and the skewed rotor design helps to achieve very smooth rotation over the entire speed range. Motors are normally equipped with resolver feedback, but for more demanding applications the SinCos® feedback option offers resolutions up to 72,000 counts/rev. The higher resolution results in better positioning accuracy as well as improved dynamic performance.



	Stall Torque $M_O$ Nm	Stall Current $I_O$ A	Torque constant $K_T$ Nm/A/ph	Rotor <sup>①</sup> inertia $J$ kgmm <sup>2</sup>	Weight $m$ kg	Rated <sup>②</sup> speed $n_n$ rpm	Rated <sup>③</sup> torque $M_n$ Nm	Rated current $I_n$ $A_{eff}$	Rated power $P_n$ kW
HDY55C4-32S	0.4	1.1	0.125	24	1.4	5000	0.35	1.04	0.18
HDY70C4-44S	1.2	2.3	0.17	60	2.4	4400	1.15	2.30	0.53
HDY92C4-44S	1.5	2.9	0.17	85	4.3	4400	1.20	2.4	0.55

① Moment of inertia figures include the feedback resolver. Inertia figures for the optional brake are shown below.

② The rated speed is for 230V AC supply, and is based on a supply voltage 15% below nominal, 10% tolerance in drive characteristics and 10% tolerance in motor data

③ Rated torque applies at the rated speed

Nm Compax 1000SL with HDY055C4-32S motor

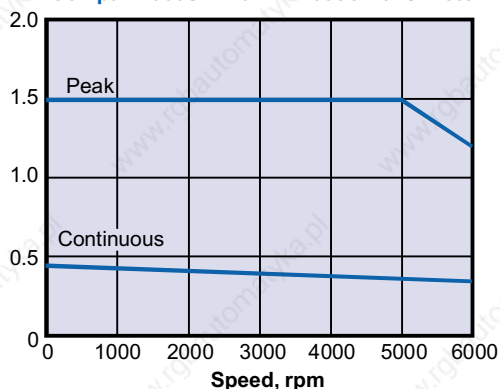

Nm Compax 1000SL with HDY070C4-44S motor

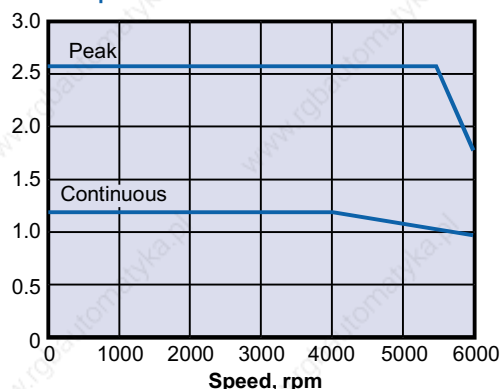

Nm Compax 1000SL with HDY092C4-44S motor

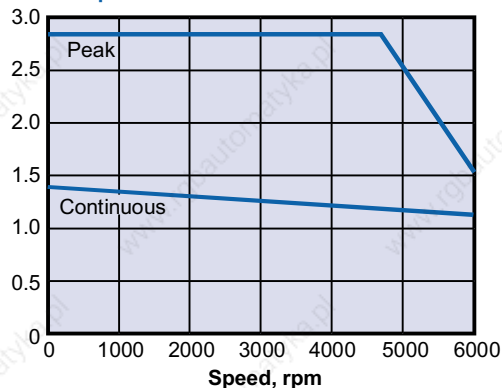

### Brake option for HDY motors

HDY series motors are available with an optional holding brake which operates from 24V DC. The brake is fitted within the motor housing behind the mounting flange. The brake option increases the length of HDY55 and HDY70 motors (see dimension diagram opposite).

Motor	Holding Torque (Nm)	Current (A)	Brake inertia (kg-mm <sup>2</sup> )
HDY55	1	0.29	1
HDY70	2	0.35	4
HDY92	5	0.5	13

**HDY55C4-32S**

resolver feedback

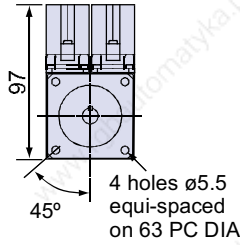
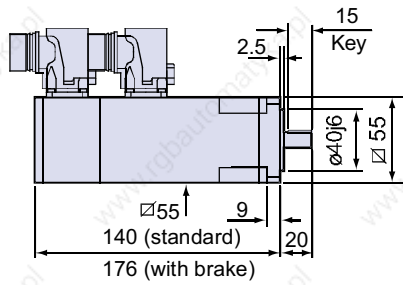

Shaft detail

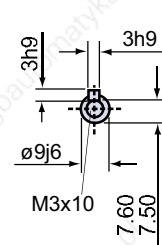

SinCos® feedback

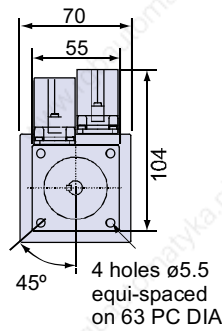
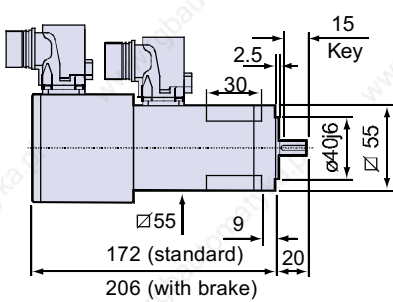

**HDY70C4-44S**

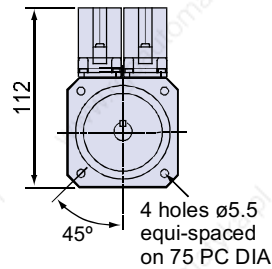
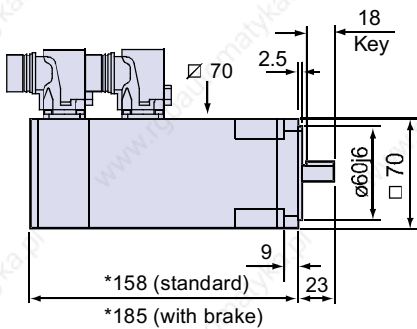

Shaft detail

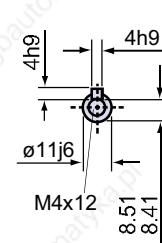

\*add 33mm for SinCos® feedback

**HDY92C4-44S**

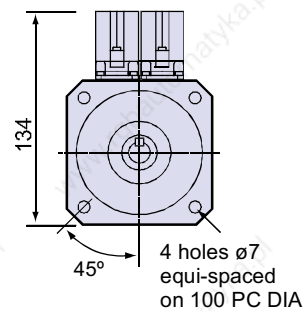
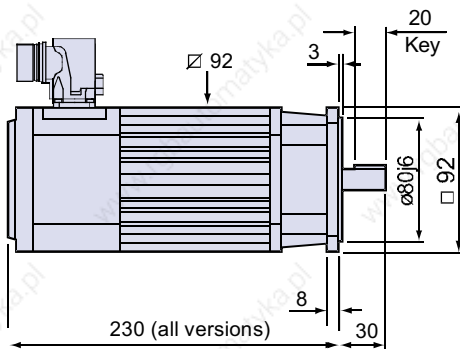

Shaft detail

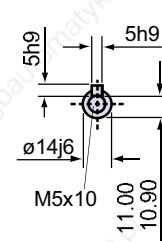

**Compax 1000SL Sy**



Initiator (limit switch) box IVD01/01

ServoManager>V5.60  
CAM-Editor Software  
BDF2/01 Hand-held terminal



- F1-Option RS485 Interface (4-wire) Bus terminator BUS 4/01
- F2-Option Interbus Interface Bus terminator BUS 3/01
- F3-Option Profibus Interface Bus terminator BUS 3/01
- F4-Option CANbus Interface Bus terminator BUS 4/01
- F5-Option RS485 Interface (2-wire) Bus terminator BUS 4/01
- F7-Option CS31 Interface (ABB) Bus terminator BUS 4/01
- F8-Option CANOpen Interface

Step-direction controller



±10V

- 1
- 2
- 3
- 4
- 5
- 6
- 7

SSK17/..cable

SSK13/..cable

**CPX 1**  
**(00/30)**



I/O Encoder module EAM 04/01  
Bus terminator BUS 01/01



CPX with E3 option

CPX with E2/4 option

SSK7/..cable

SSK17/..cable

SSK4/..cable

GBK11/..cable



2500-line encoder  
4096-line encoder

G71SSLDBI-2500  
G71SSLDBI-4096

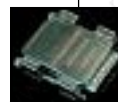

Encoder line terminator BUS 6/01



I/O module EAM 03/02

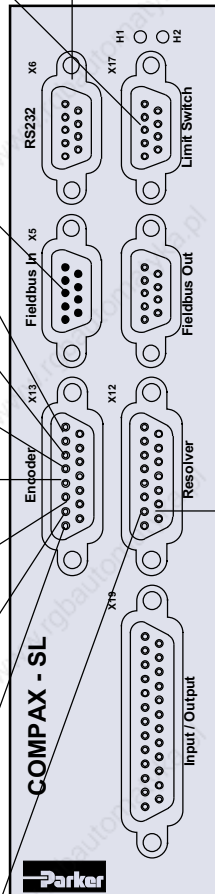

Resolver as standard  
SinCos® Feedback module -S1 - singleturn  
S2 - multiturn



# System Components



### Mating connectors

Resolver/Encoder, 15 way Male  
 Fieldbus, 9 way Female  
 Fieldbus/Limit switches, 9 way Male  
 I/O, 25 way Male

SUB-D-15S  
 SUB-D-9B  
 SUB-D-9S  
 SUB-D-25S



Brake module (dump resistor) BRM8/01

### Encoder input options:

- 1 ±10V analogue input
- 2 Step/direction input
- 3 CPX Enc. Out - CPX1000SL Enc. in
- 4 CPX1000SL Enc. Out - CPX Enc. in
- 5 Encoder bus
- 6 Encoder input
- 7 Encoder line terminator BUS 6/01

0xxSL  
 (60/70)

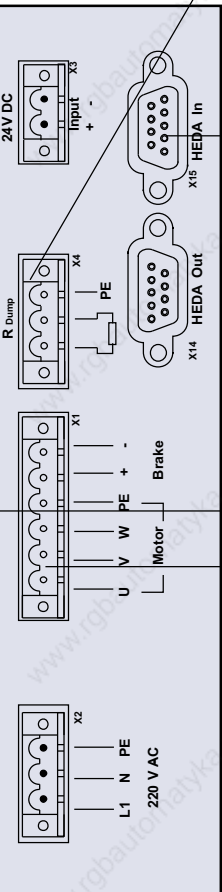

HEDA Interface option A4  
 HEDA Retro-fitting kit A4-Kit

Interface cable SSK14/..  
 Interface cable SSK15/..

HEDA bus blanking plug BUS 2/01  
 HEDA bus blanking plug BUS 2/01



**Motors**  
 HDY055 C4-32S  
 HDY055 C4-32S/BR (with brake)  
 HDY070 C4-44S  
 HDY070 C4-44S/BR (with brake)  
 HDY092 C4-44S1  
 HDY092 C4-44S1/BR (with brake)



Mains filter NFI 01/01



Motor choke MDR 08/01

### Options

SinCos®, singleturn (HDY092)  
 SinCos®, multiturn (HDY092)  
 SinCos®, singleturn (HDY055, HDY070)  
 SinCos®, multiturn (HDY055, HDY070)

SRS50  
 SRM50  
 SRS60  
 SCM60

### Standard motor cables

MOK42/..  
 REK32/..(SinCos® GBK16/..)

### Hi-flex motor cables

MOK43/..  
 REK33/..(SinCos® GBK17/..)

## COMPAX variants for special applications

In addition to the basic unit (Compax 1000SL) for general positioning tasks, software variants are also available for specific applications. Solutions are available for a range of tasks by configuring the standard unit using add-on modules. This modular approach allows hardware and software options to be added or changed in order to implement a solution tailored to meet individual requirements. Each solution is based on standard hardware and may be retro-fitted if required.

The starting point for all variants is the Compax 1000SL and this is used for general positioning purposes. The application-specific unit variants can be distinguished from the standard unit by the second two digits of the number code.

The available variants are:

- **Compax 1000SL**     **Standard positioning system**
- **Compax 1030SL**   **Rotary table controller**
- **Compax 1060SL**   **Electronic gearbox controller**
- **Compax 1070SL**   **Electronic cam controller**

The rotary table controller (1030SL) is specifically designed for any rotary application in which the target is a precise arc or angular position, or the rotation must be subdivided into a number of equal segments. The 1060SL electronic gearbox variant permits a slave axis to follow a master axis at a defined ratio, even when the master is running at an imprecise or indeterminate speed. It also allows for the processing of components or other commodities whilst in motion.

The 1070SL electronic cam controller is one of the most powerful variants of Compax. Facilities offered by this flexible unit include generation of complex cam profiles and position-dependent switching functions, multiple-profile storage and selection with dynamic switching between profiles, coupling and decoupling both at standstill and during motion.

Our qualified staff are always available to assist when selecting the appropriate variant.

## COMPAX 1030SL rotary table controller

Compax 1030SL can be used to position and control rotary tables, indexing stages and other rotary systems with high levels of precision. The required positions may be programmed in degrees, and the direction of rotation can be positive or negative. In addition to the standard Compax command set, special commands are used for the pitch calculator. This feature can be used to subdivide the rotation into equal angular segments.

Position is measured by the resolver or SinCos® encoder installed in the motor. Support is provided for external position monitoring to increase positional accuracy.

Special input and output functions are provided to allow the drive output stage to be disabled when a table clamp is used.

- Pitch calculator with up to 1000 steps per revolution
- Manual fine table setting
- External position monitoring possible

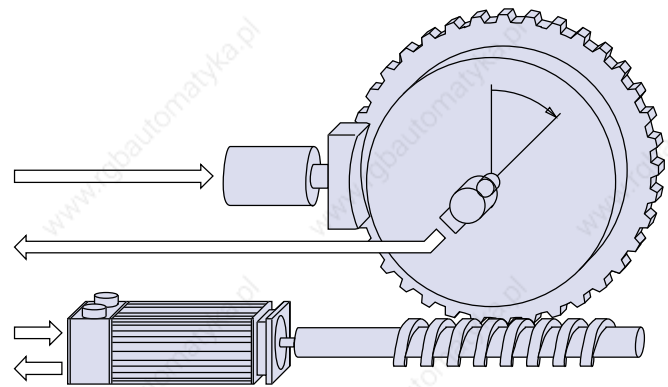

Dedicated I/O functions:

- I12: output stage enable
- I13: measuring error corrected by external position measurement
- I14: release brake
- O14: no measuring error
- O16: output stage not energised



## COMPAX 1060SL electronic gearbox controller

### Applications

Synchronous position control, synchronous speed control, processing while in motion.

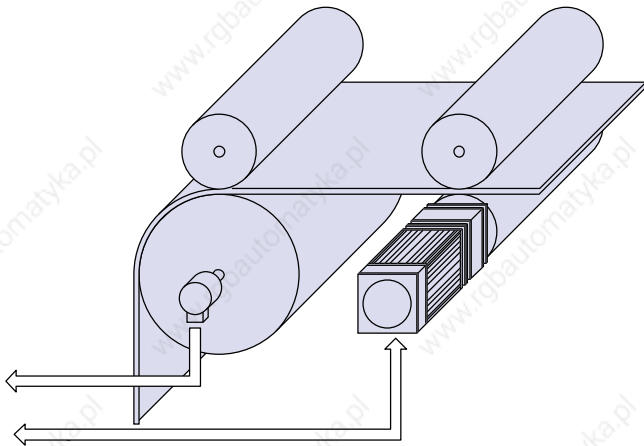

Depending on the operating mode, the Compax 1060SL can read and process an external timing signal either instead of, or in addition to, the internal master. The external timing signal can be generated by:

- an encoder on a master axis, or
- an encoder simulation from a Compax or similar drive controlling the master axis

By following the external timing signal, Compax can operate as a slave drive synchronously with the master. The following ratio may be 1:1, or may be chosen over a wide range ( $>1:1$  or  $<1:1$ ) via parameters. A negative prefix can be used to signify reversed direction of rotation. Compax 1060SL has two parameters for setting alternative standard ratios which are selected by an external input.

The external timing signal is controlled by two real time inputs (delay time 1ms). In addition to the enable input, which accepts the external encoder signal, there is a second input to select an internal or external position reference.

### Example

#### Using machine zero as the position reference

When the position reference is the machine datum point, moves performed by the internal position controller are all referred to this datum point. External command pulses from an encoder may be added to the current position in the same way as a relative move, but only when no internal move is in progress. In this case the external signal from the encoder has no effect on the machine datum position.

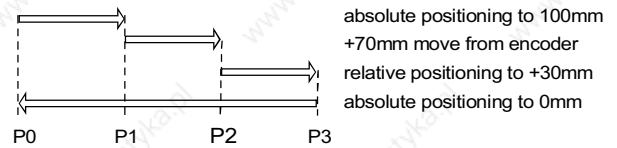

- Absolute move to 100 mm position (P1)
- Enable external encoder input (I16 = 1). Unit now travels +70 mm in response to pulses from the encoder (P2)
- Relative move of +30mm (P3)
- Absolute move to return to the datum point (P0)

#### Using the external encoder signal as a position reference

This mode is useful when a machining program is to be performed on a moving workpiece. In this case the position reference is the external encoder signal, and the internal datum point of the slave drive is shifted by the encoder pulses. The original internal datum position will now be lost, but it can be recovered by performing a Zero Search routine.

Superimposed movements are possible in this operating mode. In other words, pulses generated by the encoder will be added to those from the internal positioner. In this way the programmed positions become fixed in relation to the moving workpiece.

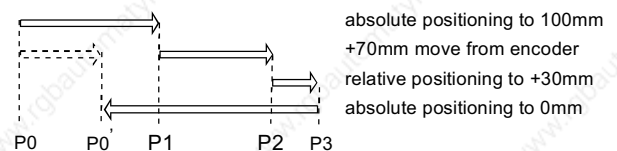

The operation is illustrated in the diagram above, in which the motion is based on the positioning cycle shown previously. Initially, the following axis is referenced to the internal datum point (P0). When the external encoder is moved, the datum point is shifted by the same amount.

The absolute command to return to the datum point (POSA 0) is used to position to the new datum position P0'; this position P0' has been shifted relative to P0 by the amount of external encoder movement.

The external encoder signals can also be enabled during an internally-programmed move and the two will be superimposed.

Special inputs:

- I14: switch the position reference between internal datum and external encoder position
- I15: external switch for the transmission ratio
- I16: enable external encoder signals

## COMPAX 1070SL electronic cam controller

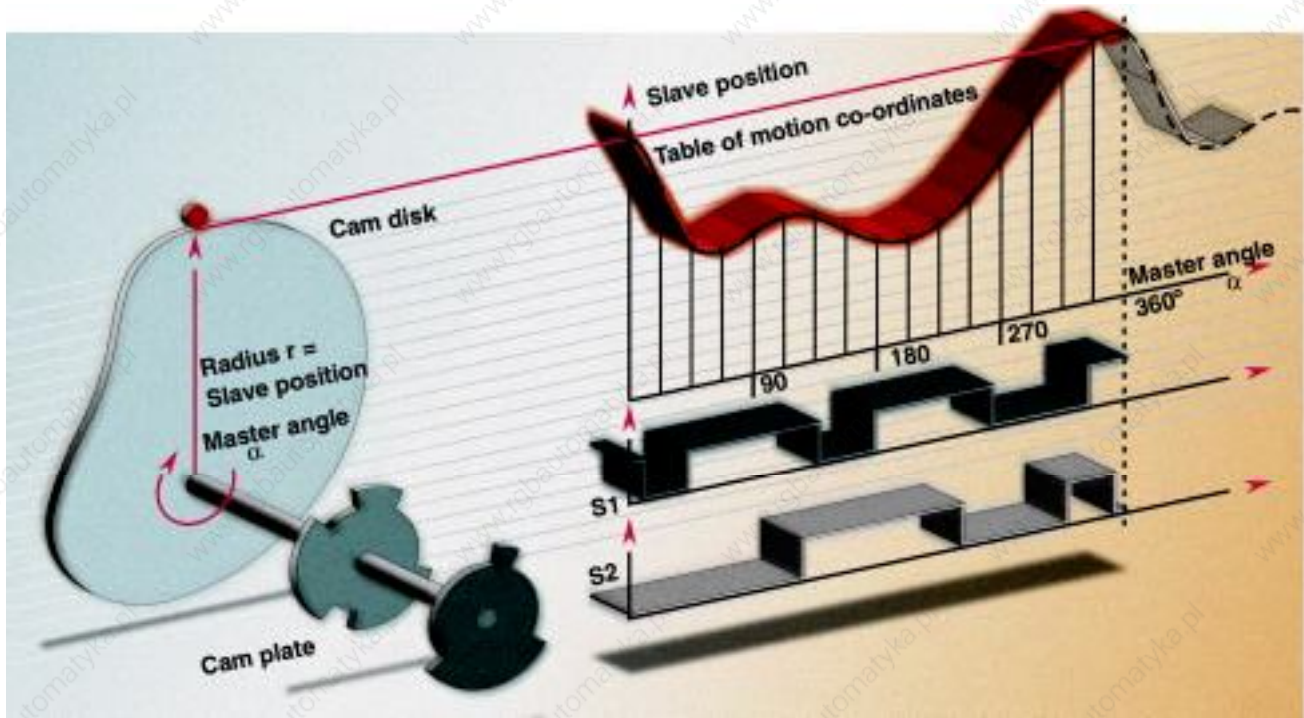

### Applications

Using the Compax 1070SL compact servo controller, mechanical cams and camshafts can be simulated electronically.

The movement of the main axis is followed by an incremental encoder. Compax takes the encoder output and generates the motion profile of the slave axis according to the required movement relationship. The motion which would normally be performed by a cam follower is now produced directly by the slave axis servo motor.

The result is an extremely flexible system which permits dynamic timing adjustment, instant change of cam profile with unlimited alternatives, coupling and decoupling both at standstill and during motion - all facilities which are either difficult or impossible to achieve with mechanical cams.

A typical field of application is in the packaging industry. Decentralising the cam generating function avoids the need for mechanical coupling components, reduces the space required and eliminates the need to manufacture, hold and change cam disks as process requirements change. The result is frequently a smaller machine, a reduction in cost, shorter setup times and reduced maintenance.

### The implementation

The cam profile is stored in the Compax 1070SL as a sequence of reference points in non-volatile memory. Up to 2500 reference points may be stored, and the Compax controller interpolates between them in a linear fashion. Provided the 2500-point memory capacity is not exceeded, several profiles can be stored at the same time and selected externally. An 'interlink curves' function allows for dynamic switching between profiles for even greater flexibility.

The profile generator derives both velocity and acceleration feedforward signals from the reference point data. This information is used to minimise the tracking error of the slave axis. Repeatability of angular positioning is up to 0.02 degrees (1.2 arc-minutes).

The camshaft and cam switching plates are simulated using auxiliary functions which can be assigned to all reference points. Compax has the following auxiliary functions:

- Programmable control of 8 digital outputs. The initial pattern will be set up when the first reference point is processed.
- An analogue voltage may be generated via 2 analogue outputs.

The analogue output voltage is in the range  $\pm 10V$ . The level is determined by the angle of the master axis and the programmed value for that position.

## Cam controller features

### Primary functions

The control unit's primary task is to move a slave axis in accordance with the profile of motion programmed by the user and depending on the angle of the master axis. Several slave axes with individually programmed profiles can be coupled to the master axis. In addition, the unit is capable of controlling auxiliary functions at specific points in the cycle, for example switching an external actuator.

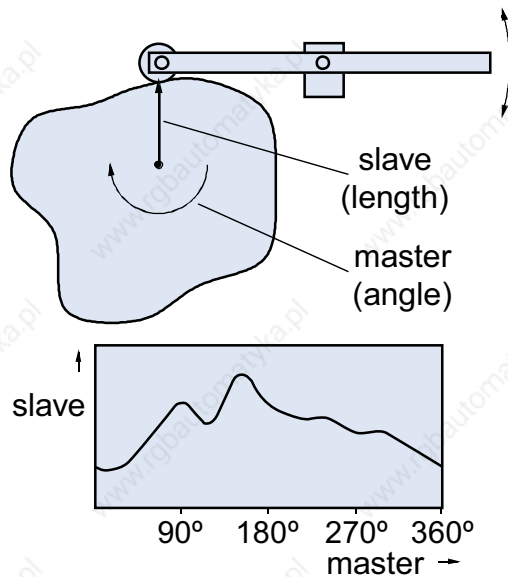

### Coupling and decoupling the slave axis

The slave axis can be coupled and decoupled whether the master axis is stationary or already in motion.

#### Coupling and decoupling at standstill

The normal way to initialise the slave axis is by performing a homing routine after the power has been applied. Once the required cam profile has been selected, Compax is then ready to follow the master axis. When the master axis begins to move, the slave axis makes its own move in accordance with the selected profile.

#### Coupling and decoupling when the master axis is in motion

The following options are available for coupling to a rotating master axis:

(a) When the external 'couple' signal is received, Compax calculates an approach curve which will meet the preset profile at a programmed master position  $M_S$ . When the coupling signal arrives, sufficient time must be available to synchronise the slave axis by the time the synchronous position  $M_S$  is reached.

Decoupling occurs in a similar manner. When the coupling signal is removed, the slave axis exits from its synchronous mode and decelerates to rest at  $S_0$  by the time the master reaches the braking position  $M_B$ .

### Coupling in & out - mode (a)

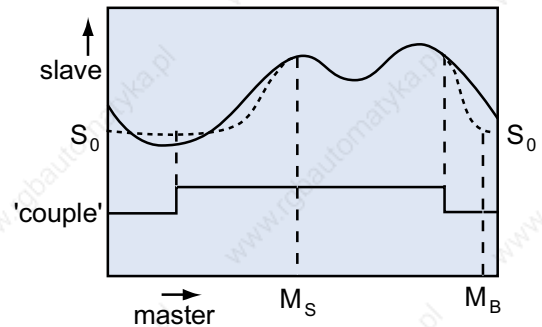

(b) After the external 'couple' signal is received, the slave axis only begins to move when the master axis has reached a programmed couple-in position ( $M_E$ ). This ensures that the approach curve is predictable and constant. Decoupling occurs in a similar way, with the slave axis exiting the synchronous mode only at a programmed couple-out position ( $M_A$ ) regardless of when the coupling signal is removed. As before, the axis slows to a stop at the braking position ( $M_B$ ) to come to rest at  $S_0$ .

### Coupling in & out - mode (b)

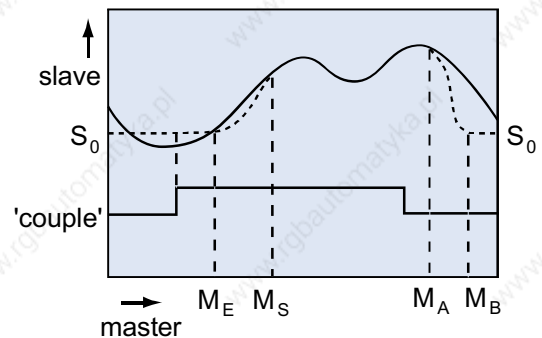

### Profile change during motion

The option of dynamic curve changeover allows for transfer between one profile and another with no discontinuity. In this way the cam profile may be modified for instance as a function of speed.

### Programmable cycle count

The slave axis may be made to follow the master axis continuously, or coupling to the master axis may be terminated automatically after a defined number of cam cycles.

### Lag warning

Compax has the ability to monitor the variation between the actual position and the programmed profile. The difference is compared with a preset error window, and an output signal is generated whenever this value is exceeded.



## Engineering solutions in motion control...

The performance requirements of today's automation tasks demand reliable, cost-effective solutions and the reassurance of competent technical backup. A comprehensive product range supported by highly-trained, experienced application engineers forms the basis of Parker's motion control capability.

With the combined resources of world-class companies like Digiplan, Compumotor, Hauser and Daedal, Parker can offer a range of automation products which is second to none. High-performance stepper and servo systems combined with powerful, flexible controllers are complemented by a wide selection of mechanical positioning systems. This

equipment is supplied and supported through a worldwide network of Automation Technology Centres, each with factory-trained staff who specialise in the application of high-technology motion control systems.

Our aim is to give customers a competitive advantage by providing top-grade equipment and unrivalled technical support. Whether the application is in industrial automation, production machinery, instrumentation or research, you can be certain that your system will be precision-engineered and backed by the Parker guarantee of quality and reliability.



## Parker - we engineer solutions in motion control

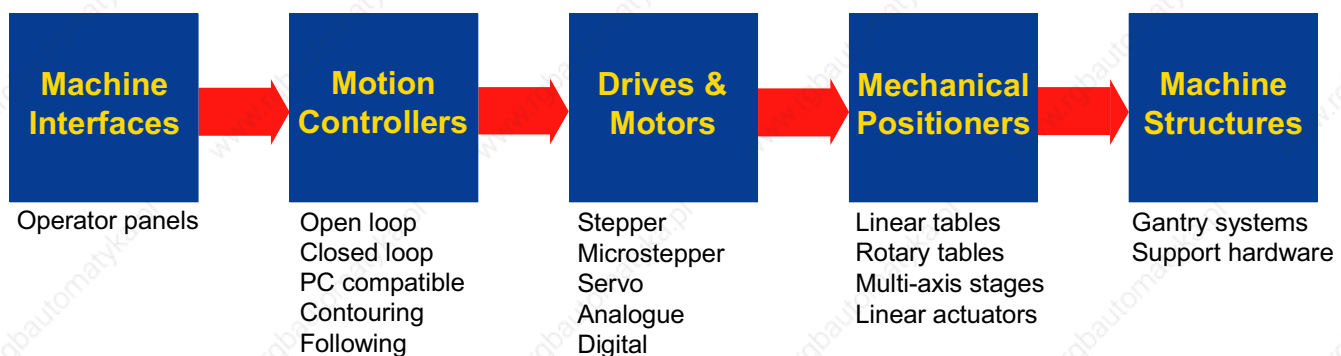

**Parker Hannifin plc**  
Electromechanical Division  
21 Balena Close  
Poole, Dorset. BH17 7DX UK  
Tel: +44 (0)1202 69 9000  
Fax: +44 (0)1202 69 5750  
Website: [www.parker-emd.com](http://www.parker-emd.com)  
e-mail: [emdsales@parker.com](mailto:emdsales@parker.com)

**Parker Hannifin GmbH**  
Electromechanical Division  
Robert-Bosch-Str. 22  
D-77656 Offenburg, Germany  
Tel: +49 (0)781 509-0  
Fax: +49 (0)781 509-176  
Website: [www.parker-emd.com](http://www.parker-emd.com)  
e-mail: [vertrieb@parker-emd.com](mailto:vertrieb@parker-emd.com)