

MOUNTING REQUIREMENTS FOR UIPMA

1. The shape of the customer interface over the active area shall be: $\square 0.05$
2. The roughness of the customer interface over the active area shall be: $\sqrt{Ra} 1.6$
3. Before sticking the sensor, the interface surface shall be free of all traces of dirt, grease, foreign objects, and burrs.
4. The bending of the flat flex cable shall be: $\varnothing 3$ mm min.

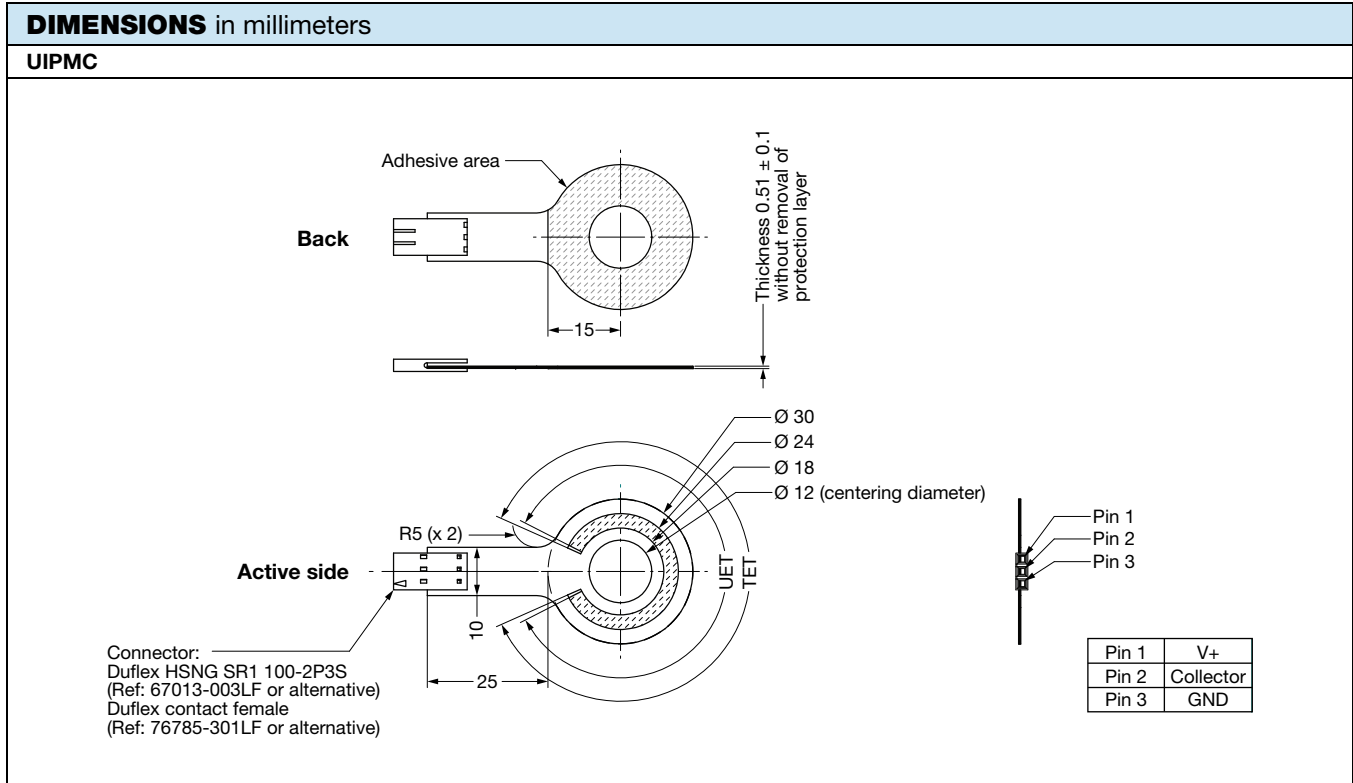

ELECTRICAL DIAGRAM

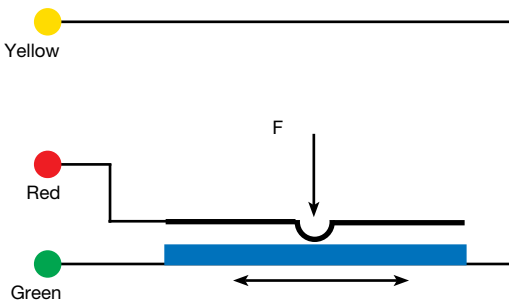

The voltage varies according to the position of the presser on the deformable membrane.

SPECIFIC VERSIONS (on request)

- Other electrical or mechanical characteristics
- Other bases
- Integration in equipment
- Other versions: outdoor design, ...
- Integration in equipment (flat flex cable, contacts, wires, ...)

PRESSERS

Wiper Type A

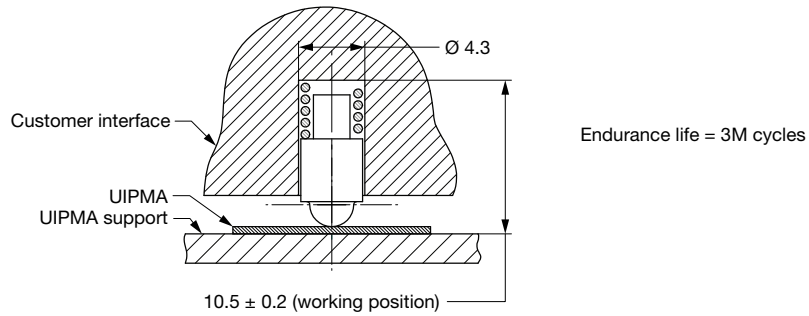

Wiper Type B

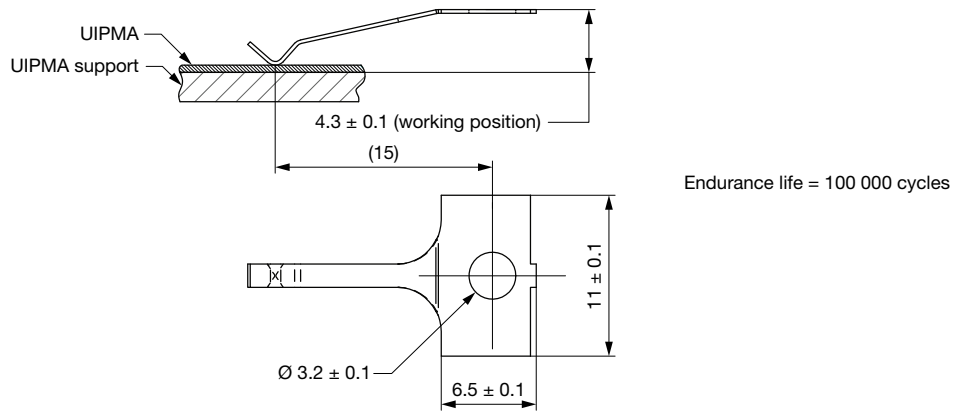

Wiper Type D

