

Solid State Sensors

SR16/17 Hall Effect Vane Sensors

SR16/17 Series

ELECTRICAL CHARACTERISTICS -20°C TO 85 °C, 3.8 TO 30 VDC

	Min.	Max.	Remarks
Supply voltage		3.8 to 30	VDC
Current consumption	—	9	mA (off) 10 mA (on)
Output voltage (operated)	—	0.40 V	Sinking 20 mA max.
Sink current (operated)	—	20	mA
Output leakage current (released)	—	10 μ A	$V_{OUT} = 30$ VDC, $V_{CC} = 24$ VDC
Output switching time			
Rise, 10 to 90%	—	1.5 μ s	$V_{CC} = 12$ V, $R_L = 1.6$ K Ω , $C_L = 20$ pF
Fall, 90 to 10%	—	1.5 μ s	$V_{CC} = 12$ V, $R_L = 1.6$ K Ω , $C_L = 20$ pF
Operating Temperature	-20°C to +85°C (-4°F to +185°F)		

MECHANICAL CHARACTERISTICS

Operating Range 12 VDC @ 25°C

Operate	Release
1.5° \pm 2.0°	3.0° \pm 2.5°

CONDITIONS

Target engagement distance 0.150 in to 0.300 in

RPMs 0 to 5000

Slot depth 0.250 in min.

BLOCK CIRCUIT WIRING DIAGRAM

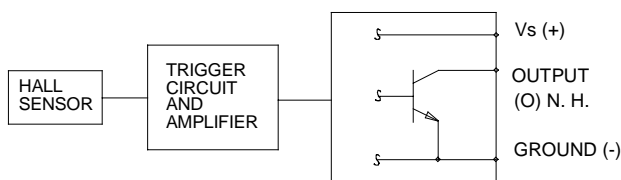

SPEED SENSING INTERFACE

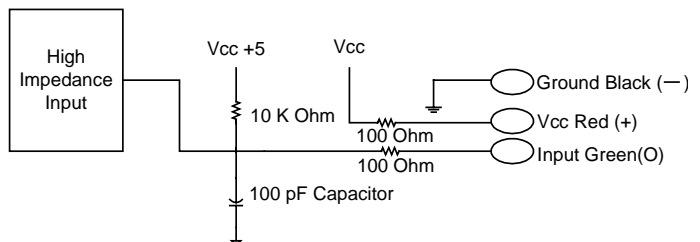

MOUNTING DIMENSIONS (for reference only) mm/in

SR16/17 Series Vane Sensors

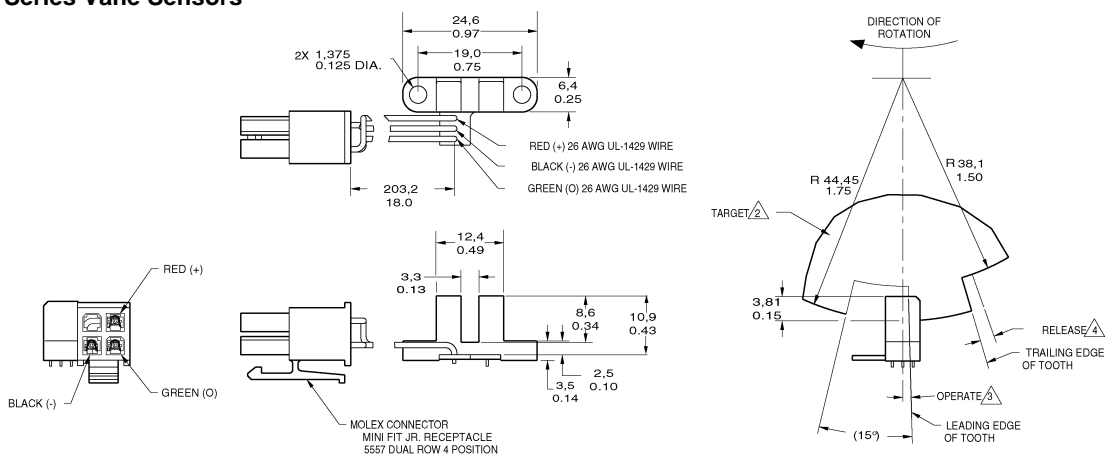

SR16C-J4

Solid State Sensors

SR16/17 Hall Effect Vane Sensors

SR16/17 Series

MOUNTING DIMENSIONS (for reference only) mm/in

SR16/17 Series Vane Sensors

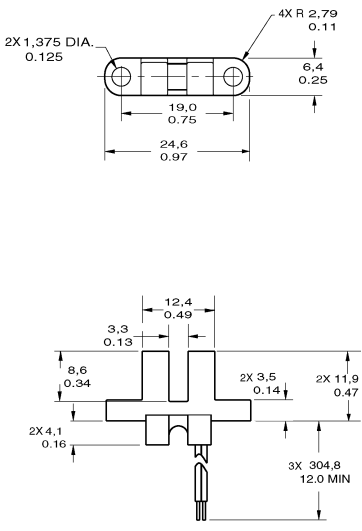

SR16C-J6

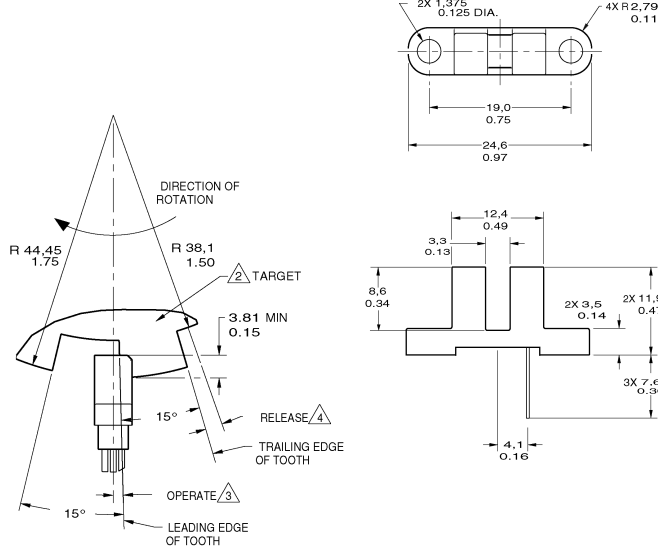

SR16C-N

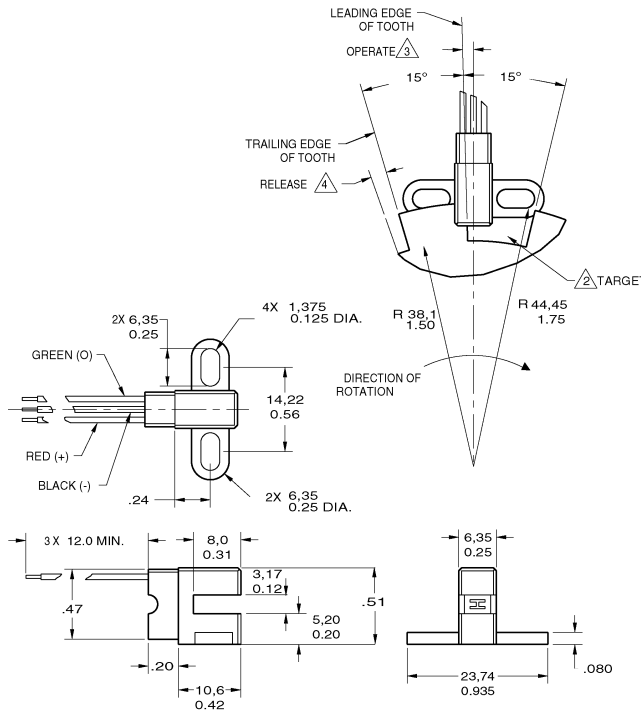

SR17C-J6

Notes:

1. Mounting specification: non-ferrous #4 machine head screws with .25 OD washers torqued to 3-5 in-lbs.
2. Suggested target configuration, material: .045 low carbon steel, high permeability, low residual induction.
3. Operate (degrees) is the angular distance from the leading edge of the tooth to the centerline of the sensor.
4. Release (degrees) is the angular distance from the trailing edge of the tooth to the centerline of the sensor.
5. Operating specification is based on target shown.