

EDB9200_E/GB
00375316

Lenze

Antriebstechnik

Operating Instructions

***Servo controller
9200 series***

These Operating Instructions are valid for the controllers with the nameplate data:

9212 E.5x
9215 E.5x
9217 E.5x

9222 E.5x.5x
9223 E.5x.5x
9224 E.5x.5x
9225 E.5x.5x
9226 E.5x.5x
9227 E.5x.5x
9228 E.5x.5x

Controller type

Enclosure IP20

Hardware version + index

Software version + index

Corresponds to the German edition of 05/18/1995

Edition of: 05/18/1995

Date of print: 05/29/1995

How to use these Operating Instructions...

These Operating Instructions are divided into three parts:

- **Planning and installation**

This part comprises the technical data of the supply modules, the axis modules and of accessories available for the 9200 series (e. g. motors), instructions for installation and wiring and descriptions of the drive connections.

- **Parameter setting**

Describes the basics of parameter setting and informs about commissioning, important functions and the operation via serial interface. At the end of this part you will find a comprehensive code table and a signal flow chart.

- **Service**

Explains error messages and gives hints for trouble-shooting.

To locate information on specific topics, simply refer to the table of contents at the beginning and to the index at the end of the operating instructions.

A series of different symbols provide quick reference and highlight important items.

Note

This symbol refers to items of information intended to facilitate operation.

Caution

Notes which should be observed to avoid possible damage to or destruction of equipment.

Warning

Notes which should be observed to avoid health risks to the operating personnel.

Fehler! Es ist nicht möglich, durch die



Safety information

for electrical equipment used in industrial power installations.



The electrical devices and machines described are equipment to be used in industrial power installations. This equipment incorporates hazardous parts that are live, moving or rotating during operation. Severe personal injury or damage to equipment may occur if e. g. any required enclosures or covers are inappropriately removed or the equipment is insufficiently serviced.

The personnel responsible for the safety of the equipment must therefore ensure that:

- only qualified personnel are permitted to install, operate and maintain the devices
- these Operating Instructions and any other documentation about the equipment are consequently observed and always available to the personnel working with the equipment.
- non-qualified personnel is prohibited from working with the equipment or in its vicinity.
- the system is installed in accordance with local regulations.

A qualified person must by training be familiar with all relevant standards and safety regulations and therefore be authorized to perform the required work (For further details cf. IEC 364).

These safety instructions do not claim to be exhaustive. Should any questions or problems occur, please contact your nearest Lenze representative.

The information given in these Operating Instructions refer to the specified hardware and software versions of the equipment.

The specifications, processes and circuitry described in these Operating Instructions are for guidance only and must be adapted to your specific application.

Lenze cannot be held responsible for the applicability of the processes and circuitry indicated.

The specifications in these Operating Instructions describe, not guarantee the features of the equipment.

Hardware, software and documentation of the equipment have been carefully checked by Lenze. Faultlessness cannot be guaranteed.

Subject to technical alterations.

Content

Planning and Installation

| | | |
|--|-----------|----|
| 1. Features | 5 | |
| 2. Technical data | 6 | |
| 2.1. General data | 6 | |
| 2.2. Unit-specific data | 6 | |
| 2.2.1. Rated data of supply modules | 6 | |
| 2.2.2. Rated data of axis modules | 7 | |
| 2.3. Dimensions | 8 | |
| 2.4. Extension of delivery | 8 | |
| 2.5. Application as directed | 8 | |
| 2.6. Manufacturer's certification | 9 | |
| 3. Installation | 10 | |
| 3.1. Mechanical installation | 10 | |
| 3.2. Electrical installation | 11 | |
| 3.2.1. Combination of several axis modules with one supply module | | 12 |
| 3.2.2. Screening and earthing | 14 | |
| 3.2.3. Radio interference suppression | 16 | |
| 4. Drive connections | 17 | |
| 4.1. Power connections | 17 | |
| 4.1.1. Mains and motor connection | 17 | |
| 4.1.2. External brake resistor | 18 | |
| 4.2. Control connections of supply module | 20 | |
| 4.2.1. Overheat of internal brake resistor (9210 X1) | 20 | |
| 4.2.2. Mains and DC-bus monitoring (9210 X3) | 20 | |
| 4.2.3. State bus | 21 | |
| 4.3. Control connections axis module | 22 | |
| 4.3.1. Control terminals | 22 | |
| 4.3.2. Analog input and outputs | 22 | |
| 4.3.3. Digital inputs and outputs | 23 | |
| 5. Application examples | 26 | |
| 5.1. Variant with integrated positioning module 2211PP | | 26 |
| 5.2. Wiring with positioning control SX-1 | 28 | |
| 5.2.1. Diagram 1: Mains supply | 28 | |
| 5.2.2. Diagram 2: Control circuit 230V | 29 | |
| 5.2.3. Diagram 3: Control circuit 24V | 30 | |
| 5.2.4. Diagram 4: Control connections 9200 - SX1 | 31 | |
| 5.2.5. Diagram 5: Control connections SX1 | 32 | |
| 6. Accessories | 33 | |
| 6.1. External brake resistors | 33 | |
| 6.2. Mains chokes | 33 | |
| 6.3. RFI filter | 34 | |
| 6.4. External fuses | 34 | |
| 6.5. System cables | 34 | |
| 6.5.1. System cables for control terminal block X5 | 34 | |
| 6.5.2. System cables for master frequency selection X2 and incremental encoder output X4 | 35 | |
| 6.5.3. System cables for resolver X3 | 36 | |
| 6.5.4. System cables for power supply of servo motors | | 37 |
| 6.5.5. System cables for supply for fan and brake | 38 | |
| 6.6. Motors | 39 | |

| | |
|--|-----------|
| 1. LCD display | 40 |
| 1.1. Key functions | 40 |
| 1.2. Plain-text display | 40 |
| 2. Basics of parameter setting | 41 |
| 2.1. Change parameters | 41 |
| 2.2. Save parameters | 42 |
| 2.3. Load parameter | 42 |
| 2.4. Examples | 43 |
| 3. Commissioning | 45 |
| 3.1. Basic parameter setting | 45 |
| 3.2. Input of motor nameplate data | 47 |
| 3.3. Setting of operating parameters | 48 |
| 4. Additional functions | 50 |
| 4.1. Mains failure detection with DC-bus control | 50 |
| 4.1.1. Requirements | 50 |
| 4.1.1. Wiring | 52 |
| 4.1.2. Setting | 53 |
| 4.2. Homing mode | 56 |
| 4.3. Further additional functions | 57 |
| 5. Serial interfaces | 58 |
| 5.1. LECOM1 interface X1 | 58 |
| 5.2. LECOM status messages | 59 |
| 5.3. Table of attributes | 60 |
| 6. Code table | 63 |
| 7. Signal flow chart axis modules | 72 |
| 1. Monitoring messages | 74 |
| 1.1. Monitoring without activating pulse inhibit | 74 |
| 1.2. Monitoring with activating pulse inhibit | 74 |
| 1.3. Monitoring with TRIP setting | 74 |
| 2. LED displays | 78 |
| 2.1. LED supply module | 78 |
| 2.2. LED axis module | 78 |
| 3. Checking the power stage | 79 |
| 3.1. Checking the mains rectifier | 79 |
| 3.2. Checking the output stage | 79 |

Index

83

Planning and installation

1. Features

The 9200 controller series comprises 3 supply modules (types 9212, 9215 and 9217) and 7 servo modules (types 9222-9228 with motor peak currents ranging from 8 to 82 A) for asynchronous servo motors.

- Digital control by 16-bit microcontroller and 3 ASICs
- Field-orientated vector controlled current
- Four-quadrant operation, any speed and torque direction
- Inverter with IGBTs
- Selectable chopper frequency either low noise 8kHz or silent 16kHz
- Supply and axis modules can be combined for single or multi-axis operation
- Efficient energy exchange by means of DC-bus for multi-axis operation
- Controlled operation even during mains interruption.
- Supply modules with integrated brake chopper and brake resistors
- Short-circuit protected inverter outputs
- When using the specified mains chokes, the units comply with the overvoltage class 2 according to VDE 0160
- I x t monitoring as overload protection for the inverter
- Parameter setting and diagnosis via keypad and 2-line LCD display in plain text German, English, and French language
- Control parameters can be modified ON-LINE
- Isolated digital inputs and outputs for 24V-PLC level
- Electronic incremental encoder simulation for use by other drives
- Master frequency input for positioning, master/slave operation or angular synchronization
- Drift free standstill in the case of master frequency input or quick stop QSP
- Serial interface LECOM A/B (RS232 and RS 485) for parameter setting, control and diagnosis
- Enclosure IP20
- Variants with additional modules are available
- Approvals: UL 508, File no. 132659
VDE 0160, VDE reg. no. 1799

2. Technical data

2.1. General data

| | |
|---|---|
| Enclosure | Steel sheet housing, IP20 to DIN 40050 |
| Noise immunity: | Severity 4 to IEC 801-4 |
| Influence of installation height on rated current: | 1000 m: 100% rated current 2000 m: 95% rated current 3000 m: 90% rated current 4000 m: 85% rated current |
| Ambient temperature | 0 °C...+45 °C during operation -25 °C...+55 °C during storage -25 °C...+70 °C during transport |
| Permissible humidity | relative humidity 80%, no condensation |
| Permissible pollution | Pollution strength 2 to VDE 0110, part 2. Do not expose units to corrosive or explosive gases. |

2.2. Unit-specific data

2.2.1. Rated data of supply modules

| Supply module type | Order no. | 9212_E | 9215_E | 9217_E |
|--|---------------------|--|-----------|-----------|
| | | 33.9212_E | 33.9215_E | 33.9217_E |
| Mains voltage | [V] | 3 x 480; 50 - 60 Hz permissible range 3 x 330...528 ± 0%; | | |
| DC-bus voltage (at rated current) | [V] | 1.35 x V _{mains} | | |
| Mains current | [A _{eff}] | 6 | 20 | 40 |
| Permanent power¹⁾ (at V_{mains} = 3 x 480 V) | [kW] | 4.9 | 16.5 | 33 |
| Peak power (t=5 s) | [kW] | 12 | 37 | 60 |
| Permanent brake power (with int. brake resistor) | [W] | 250 | | |
| Permanent brake power (with appropriate ext. brake resistor) | [kW] | 4.9 | 16.5 | 33 |
| Peak brake power with int. or ext. brake resistor | [kW] | 19.4 | 51.1 | 66.1 |
| min. permissible resistance for int. or ext. brake resistor | [Ω] | 29 | 11 | 8.5 |
| Power loss (without brake resistor) | [W] | 110 | 110 | 110 |
| Weight | [kg] | 9.0 | 10.5 | 11.0 |

¹⁾ With low mains voltages, the permissible permanent power is reduced to $P_{zul} = P_N \cdot V_{mains} / 480 \text{ V}$

2.2.2. Rated data of axis modules

| Axis module type | | 9222_E | 9223_E | 9224_E | 9225_E |
|--|----------------------|----------------------|-----------|-----------|-----------|
| | Order no. | 33.9222_E | 33.9223_E | 33.9224_E | 33.9225_E |
| Output current ($f_{ch} = 8$ kHz) | [A _{eff}] | 4.5 | 5.5 | 13.5 | 18 |
| Output current ($f_{ch} = 16$ kHz) | [A _{eff}] | 2.3 | 2.9 | 6.9 | 9.5 |
| Peak current (for $t = 5$ s at $f_{ch} = 8$ kHz; for $t = 2.5$ s at $f_{ch} = 16$ kHz) | [A _{eff}] | 8 | 10 | 24 | 33 |
| Permanent power ($V_A = 3 \times 480$ V and $f_{ch} = 8$ kHz) | [kVA] | 3.7 | 4.5 | 11.2 | 14.9 |
| Permanent power ($V_A = 3 \times 480$ V and $f_{ch} = 16$ kHz) | [kVA] | 1.9 | 2.4 | 5.7 | 7.9 |
| Peak power ($V_A = 3 \times 480$ V) | [kVA] | 6.6 | 8.3 | 19.9 | 27.4 |
| Output voltage V_A | [V] | 3 x 0... V_{mains} | | | |
| Field frequency | [Hz] | 0... ± 300 | | | |
| Speed | [min ⁻¹] | 0... ± 8000 | | | |
| Power loss at permanent power | [W] | 200 | 250 | 340 | 510 |
| Power loss at controller inhibit | [W] | 45 | 45 | 45 | 125 |
| Weight | [kg] | 9.2 | 9.5 | 9.5 | 20.5 |

| Type | | 9226_E | 9227_E | 9228_E |
|--|----------------------|----------------------|-----------|-----------|
| | Order no. | 33.9226_E | 33.9227_E | 33.9228_E |
| Output current ($f_{ch} = 8$ kHz) | [A _{eff}] | 25 | 32 | 46 |
| Output current ($f_{ch} = 16$ kHz) | [A _{eff}] | 13 | 16.5 | 23.5 |
| Peak current (for $t = 5$ s at $f_{ch} = 8$ kHz; for $t = 2.5$ s at $f_{ch} = 16$ kHz) | [A _{eff}] | 45 | 57 | 82 |
| Permanent power ($V_A = 3 \times 480$ V and $f_{ch} = 8$ kHz) | [kVA] | 20.2 | 26.6 | 38.2 |
| Permanent power ($V_A = 3 \times 480$ V and $f_{ch} = 16$ kHz) | [kVA] | 10.8 | 13.7 | 19.5 |
| Peak power ($V_A = 3 \times 480$ V) | [kVA] | 37.4 | 47.3 | 68.1 |
| Output voltage V_A | [V] | 3 x 0... V_{mains} | | |
| Field frequency | [Hz] | 0... ± 300 | | |
| Speed | [min ⁻¹] | 0... ± 8000 | | |
| Power loss at permanent power | [W] | 640 | 800 | 1000 |
| Power loss at controller inhibit | [W] | 125 | 125 | 125 |
| Weight | [kg] | 21 | 22 | 22 |

2.3. Dimensions

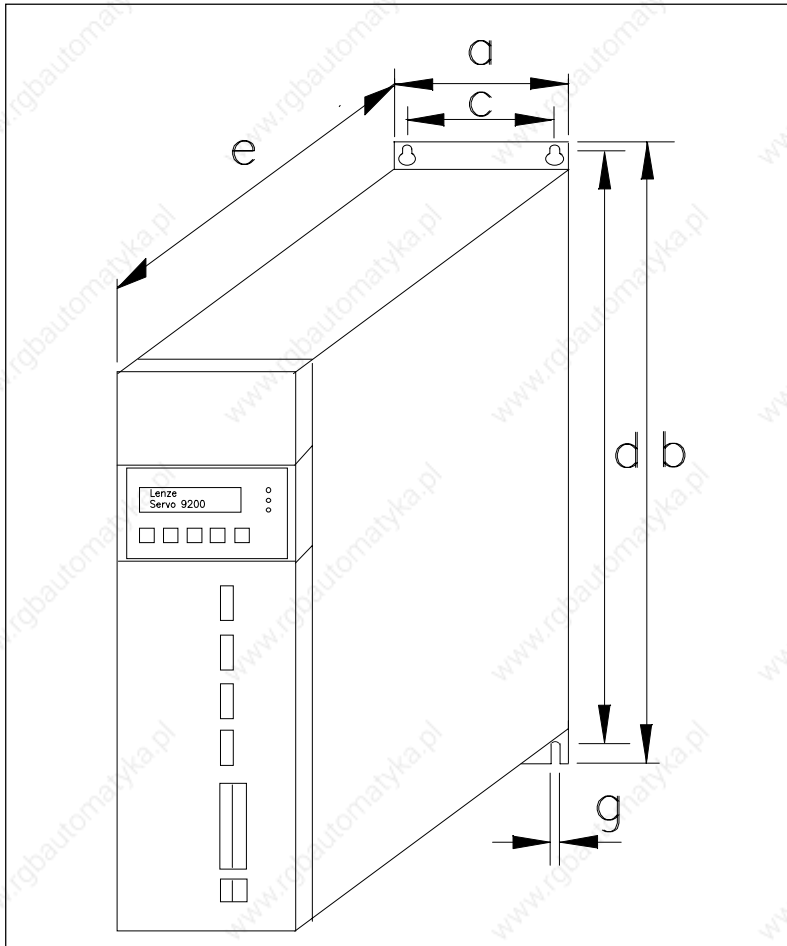

| Type | a [mm] | b [mm] | c [mm] | d [mm] | e [mm] | g [mm] |
|----------------------------|-----------|-----------|-----------|-----------|-----------|-----------|
| 9212 - 9217 9222 - 9224 | 125 | 440 | 95 | 425 | 300 | 5 |
| 9225 - 9228 | 290 | 440 | 250 | 425 | 300 | 5 |

2.4. Extension of delivery

- Axis module or supply module
- Accessory kit (busbars, State-bus line, control terminals)
- Operating Instructions

2.5. Application as directed

The units of the 9200 series are electrical units which are designed for the application in control cabinets in industrial power installations. They are designed for variable speed operations with three-phase AC motors.

2.6. Manufacturer's certification

We hereby certify that the below listed electronic controllers are control components for variable speed motors intended for the assembly into machines or together with other components to form a machine. According to the "Council directive ... relating to machinery" 89/392/EEG, our controllers are **no** machines.

The Operating Instructions supplied together with the controllers give advice and recommendations for the installation and use of the electronic equipment.

As long as the conformity with the protection and safety requirements of the "Council directive ... relating to machinery" 89/392/EEG and its amendment 91/368/EEG is not proved, operation of the machine is prohibited.

The measures required for typically configured controllers to comply with the EMC limit values are indicated in the Operating Instructions. The electromagnetic compatibility of the machine depends on the method and accuracy of the installation. The user is responsible for the compliance of the machine with the "Council directive ... relating to electromagnetic compatibility" 89/336/EEG and its amendment 92/31/EEG.

Considered standards and regulations:

- Electronic equipment for use in electrical power installations and their assembly into electrical power installations: DIN VDE 0160, 5.88 (pr EN 50178)
- Standards for the erection of power installations: DIN VDE 0100
- IP - enclosures: EN 60529, 10.91
- Base material for printed circuits: DIN IEC 249 part 1, 10.90; DIN IEC 249 part 2-15, 12.89
- Printed circuits, printed boards: DIN IEC 326 part 1, 10.90; EN 60097, 9.93
- Creepage distances and clearances: DIN VDE 0110 part 1-2, 1.89; DIN VDE 0110 part 20, 8.90
- Electrostatic discharge (ESD): prEN 50082-2, 8.92, IEC 801-2, 9.87 (VDE 0843, part 2)
- Electrical fast transient interference (Burst): prEN 50082-2, 8.92, IEC 801-4, 9.87 (VDE 0843, part 4)
- Surge immunity requirements: IEC 801-5, 10.93
- Radio interference suppression of electrical equipment and plants: EN 50081-2, 3.94; EN 55011 (VDE 0875, part 11, 7.92)
- Radio interference suppression of radio frequency equipment for industrial purposes: VDE 0871, 6.78

3. Installation

3.1. Mechanical installation

- The units are designed as housing units with enclosure IP20.
- Install the units vertically with the power terminals at the top.
- Ensure a free space of 100 mm at both the bottom and the top.

Caution!

When working with the maximum brake power, the temperature of the output air of the supply modules can reach up to 120°C.

- The axis modules should be installed at the same height at the righthand side of the supply module:
 - If the axis modules have different power outputs, the more powerful axis module must be placed directly next to the supply module.
- The interface connectors X1 to X4 and other terminals must be covered with the supplied dust protectors or unused connectors when not used.



3.2. Electrical installation



- The breakaway torque for the power terminals is 2.3 Nm (20 lb in). Marking of terminals:
at 921X: +U_G, -U_G, R_B, L1, L2, L3
at 922X: +U_G, -U_G, U, V, W

Supply modules

- Without additional protective measures (e.g. zeroing) the units may not be connected to a mains with e.l.c.b. (VDE 0160/05.88). In the event of an earth fault, a DC component in the fault current can prevent the release of the e.l.c.b.
- Operate the supply module with assigned mains choke.
- Power input
Recommended cable diameter and number of cores

| Supply module | 9212 | 9215 | 9217 |
|--|--------------------|--------------------|--------------------|
| Number of cores | 4 (L1,L2,L3,PE) | 4 (L1,L2,L3,PE) | 4 (L1,L2,L3,PE) |
| Cable diameter [mm ²] or AWG | 1,5 14/15 | 4 10/11 | 10 6/7 |

Protect input cables according to their diameter with adapted cable protection fuses.

- Protection of the input rectifier:
 - Total protection with external very quick acting fuses in the mains input (see chapter "Accessories")
 - If total protection is not required:
The normal cable protection fuses or miniature circuit breakers which are adapted to the cable diameter offer sufficient protection.
- The peak power of the supply module must be equal to or higher than the total peak power of the connected axis modules and the rated power of the supply module must also be equal to or higher than the total permanent power of the axis module (see chap. 3.2.1).



Note

The supply modules 921x hardware version E.4x onwards described in these Operating Instructions may only be used in combination with the axis modules of the hardware version E.4x and higher.

Axis modules

- Connect only one motor to each axis module.
- The cable diameter of the motor cables must correspond to the rated current of the motor.
Protection by means of:
 - cable protection fuses or
 - adapted motor protection relay
- Ensure motor protection:
 - use motor protection relay and monitor the thermostat of the motor.
- The connected motor may not be operated when the controller is enabled, except for safety shutdown.

3.2.1. Combination of several axis modules with one supply module

Please note the following conditions when combining several axis modules with one supply module:

- The State-bus (X6) can supply max. 10 axis modules.
- The sum of the total capacity of the DC-bus may not exceed a certain value (see chart):
The permissible total capacity depends on the interval between two closing operations and the mains voltage. The total capacity is the sum of the capacities of the supply module and the axis modules.
 - For intervals between two closing operations longer than 15 min, the max. permissible capacities are applied.

DC-bus capacities of the 9200 series

| Type | 9212 | 9215 | 9217 | 9222 9223 | 9224 | 9225 9226 | 9227 9228 |
|---------------------|------|------|------|--------------|------|--------------|--------------|
| C_{ZK} [μ F] | 235 | 705 | 1175 | 235 | 340 | 1100 | 2200 |

Permissible total capacity depending on the interval between two closing operations and the mains voltage

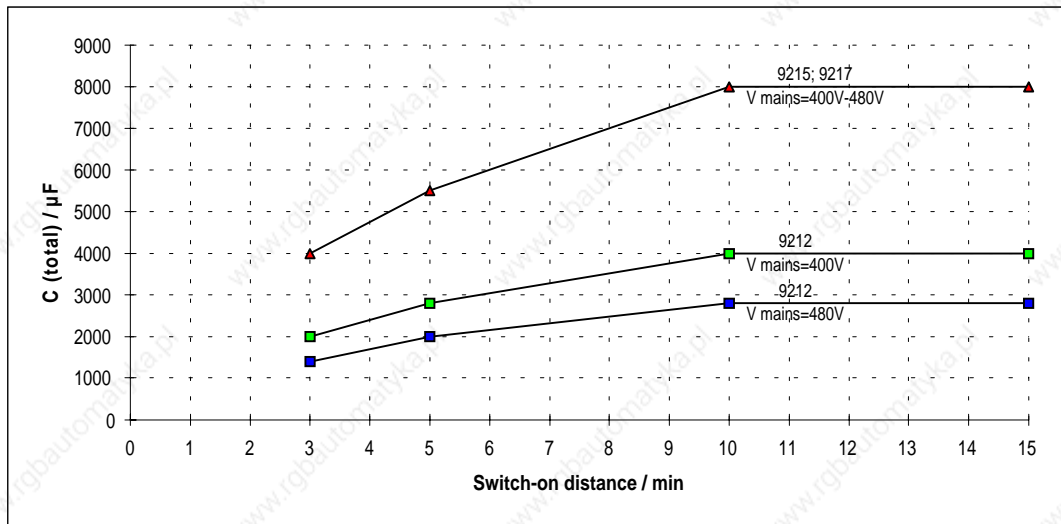

- When selecting the power of the supply module, proceed as follows to find out about the required input power.
 1. Determine the power profile of all axis modules connected to the DC-bus by means of the process profile and the load torques during a system cycle.
 2. The power losses are stated in the technical data, for units the losses are stated during rated power and for motors the power loss during rated operation. These losses are assumed to be constant during the whole cycle.
 3. Find out the resultant power by adding the power losses and the power profiles:
calculate a positive motor power
and a negative generator power.
 4. Determine the effective power during the system cycle:
Do not calculate a negative resultant power (generator power). These ranges can be taken into consideration when calculating the effective brake power.
 5. Select the supply module according to the effective power during a system cycle:
Please note that the supply module must have enough capacity to supply the effective peak power and that, in the event of mains voltage reductions, the permissible power of the supply module will be reduced according to the reduction of the mains voltage.
 6. If the calculated effective permanent power exceeds the permissible value of the supply module 9217:
Subdivide the DC-bus sets and install further supply modules.

3.2.2. Screening and earthing

In order to avoid radio interference, care must be taken with the design and connection of digital drives to avoid EMC disturbances during operation.

Digital drives are not more vulnerable to interference than analog drives, but the effect is generally different. Interference of analog devices becomes obvious as irregularities in speed. Interference of digital drives may cause program errors; therefore it is important that the drives are inhibited immediately when interference occurs. This is done by setting the TRIP function (CCr).

In order to avoid these problems, care must be taken with ground (GND), protective earth (PE) connections as well as screening.

- Screen control cables and motor cables.
- Ensure effective screening:
 - a non-earthed conductor should be used to maintain screen integrity where cables are interrupted (terminal strips, relays, fuses).

Caution!

To increase the EMC (electromagnetic compatibility), the reference GND is connected to the protective earth (PE) inside the drive.

To ensure an optimum interference suppression, the screening and the GND-PE-connection is made differently for single drive and multi drive networks.

Fehler! Es ist nicht möglich, durch die



Single drive

- Connect the screen of the control cables to PE of the drive at one end to avoid earth loops.
- GND and PE are connected by a jumper inside the drive.
- In case of firmly installed computer connections, a mains isolation (e.g. Lenze Converter 2101) is mandatory between computer and axis module.
- The screens of the motor cables
 - should be as large as possible.
 - connected to the two sides.

Multi drive networking

- When laying the ground cables, care must be taken that there are no ground loops. To ensure this, the GND-PE connection must be removed in every drive. For the 9200 drives, turn the four screws on the cover one half turn CCW and pull out the control board. Remove the jumper BR-PE on the board 9220 MP. CAUTION: Ensure that the mains has been disconnected and the drive has been switched off at least 5 minutes before removing any parts.

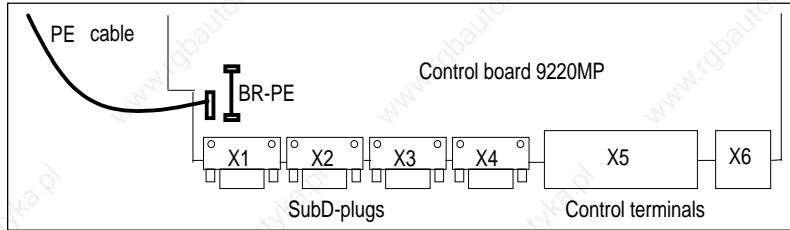

- All ground cables must then be lead to external, insulated central points, centralized again from there and connected to PE in the central supply. The PE-GND reference is necessary as the electronics insulation (SubD plug) does not allow voltages >50V~ AC at PE.
- In case of firmly installed computer connections, a mains isolation (e.g. Lenze Converter 2101) is mandatory between computer and axis module.
- The individual cable screens must be connected to external insulated central points, which are then connected to the PE potential at one point.
- The screens of the motor cables
 - should be as large as possible.
 - should be connected to the two sides.

3.2.3. Radio interference suppression

According to § 13 and § 14 of the legislation of the European Community relating to the electromagnetic compatibility of devices (EMVG v. 09.11.92) the national standards and regulations are only interim standards valid until December 31, 1995. In addition, the harmonized European standards can be fulfilled following the recommendations below. Measures against radio interference suppression depend on the site of the device to be installed:

Previous national standards

The application without radio interference suppression in electrical systems within connected working areas or industrial premises can only be allowed if, outside the industrial premises, the limit values according to VDE 0871/6.78, class B are not exceeded (General allowance according to the standard on the operation of high-frequency devices of December 14, 1984, official no. 1045/1046). For operation within residential areas or when exceeding the limit value class B outside of industrial premises, radio interference suppression according to VDE 0871, limit value class B is required.

Future harmonized standards

The standard prEN 50081-2 is valid for the radio interference suppression.

It refers to standard EN 55011 (VDE 0875, part 11, limit value class A and B).

- Within industrial premises, which are not connected to the public low-voltage supply, the limit values to EN 55011, limit value class A apply.
- Within residential areas or industrial premises, which are connected to the public low-voltage supply, the limit values to EN 55011, limit value class B apply.

Radio interference suppression to EN 55011, limit value class A or B, can be achieved by:

- Using a suitable mains filter and screening of motor cables, brake resistor cables and the power cable between mains filter and inverter (for recommended mains filters see "Accessories").

4. Drive connections

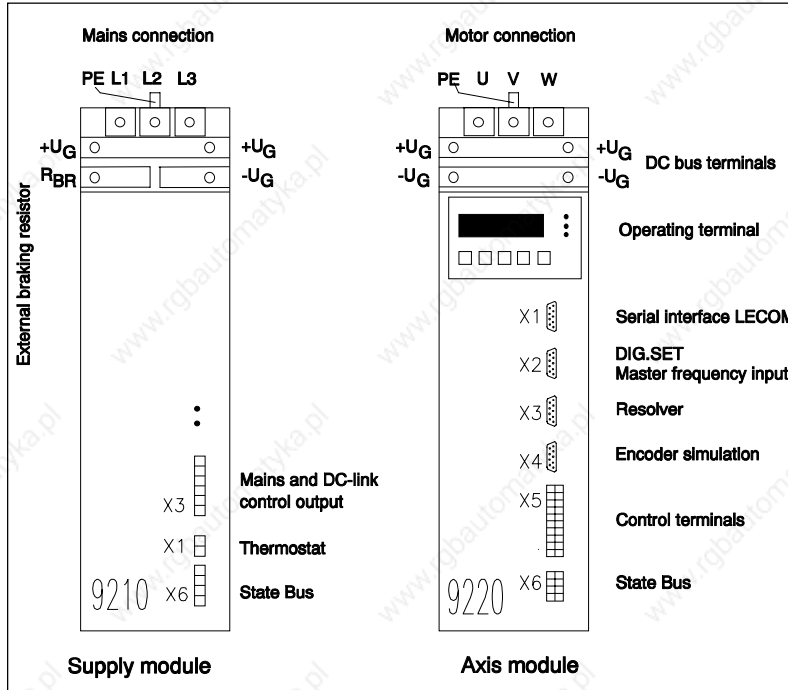

4.1. Power connections

4.1.1. Mains and motor connection



Caution!

All power terminals carry mains potential up to 5 minutes after mains disconnection.

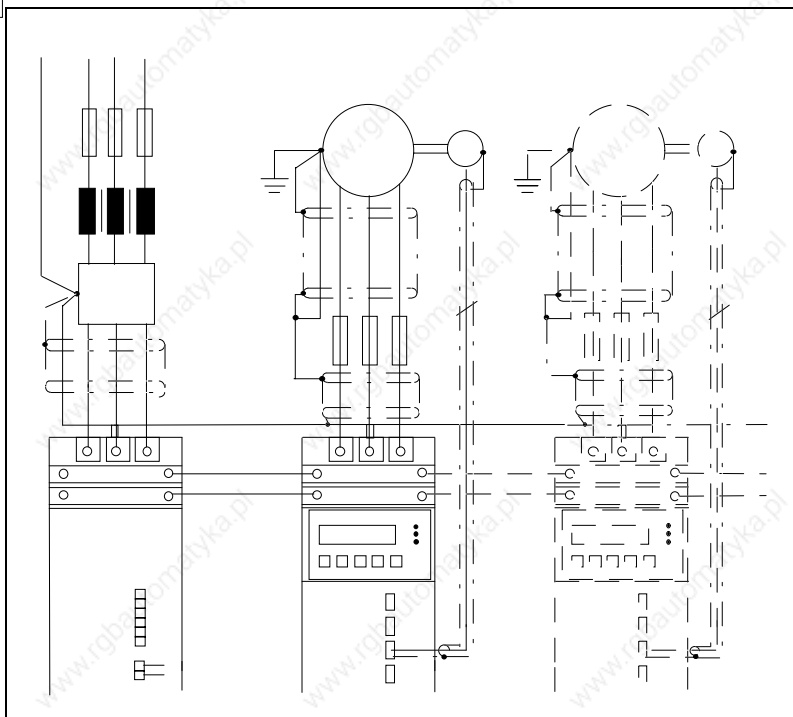

The DC-bus terminals +UG -UG and the PE terminals of the supply and axis module must be connected by means of busbars (accessory kit).

4.1.2. External brake resistor

To increase the permanent brake power, an external brake resistor with a higher permanent power can be installed instead of the internal resistor. In this case, the internal brake resistor must be disconnected.

Disconnection of the internal resistor:

1. Remove right side of the supply module housing 9210, when no voltage is applied.
2. Disconnect spade plug.
3. Connect spade plugs to tabs on the housing.
4. Close housing again.

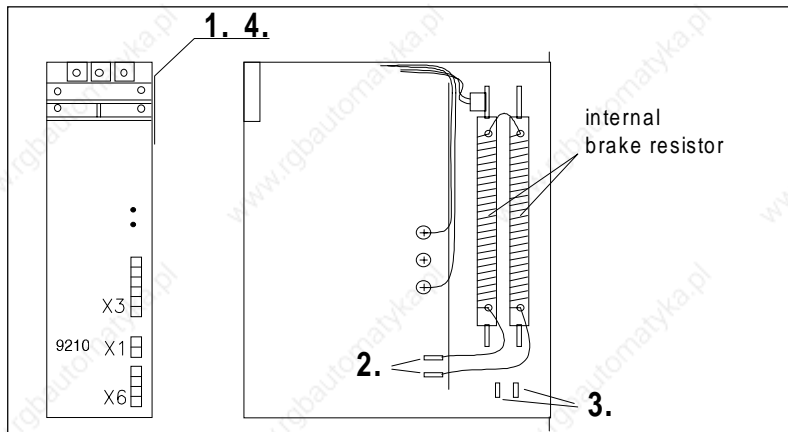

The external brake resistor must be connected to the power connections $+U_G$ and R_{BR} at the supply modules 9210. It is recommended to exclusively use resistors with integrated overload protection which disconnect the mains supply in case of overload (for recommended resistors see chapter "Accessories"). The surface temperature of the resistor may reach 360°C .

Caution!

When using brake resistors without overload protection, the resistors may burn due to a fault (e.g. mains overvoltages $>528\text{V}$, application specific overload or internal faults).



Wiring of brake resistor

Caution

K1 must additionally set controller enable!

Wiring when using the internal brake resistor

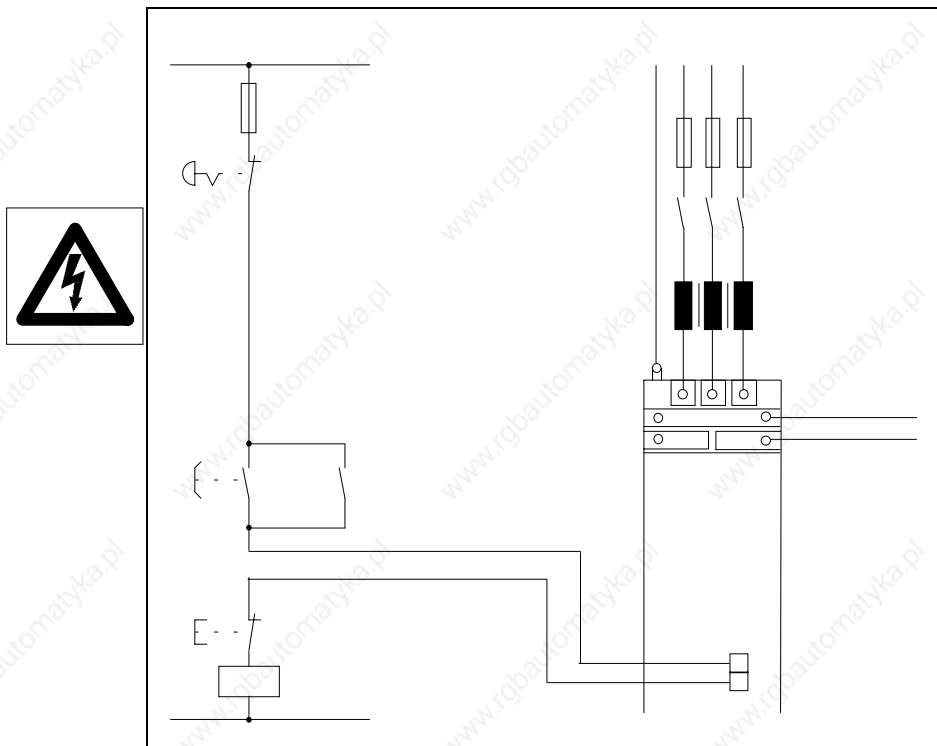

Wiring when using the external brake resistor

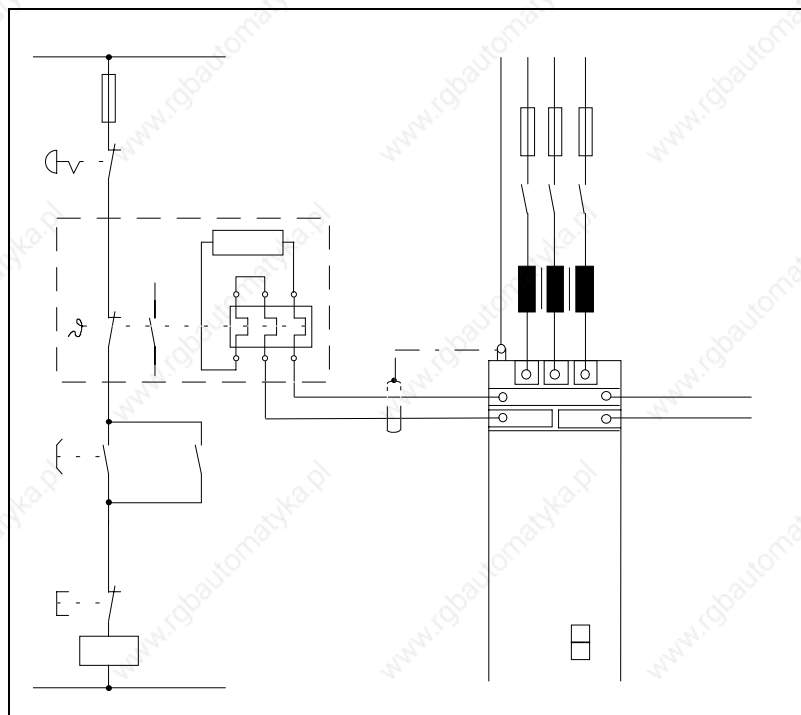

4.2. Control connections of supply module

4.2.1. Overheat of internal brake resistor (9210 X1)

The thermal contact (capacity 230V/10A) of the internal brake resistor can be accessed via the connector X1 of the supply module. It can be used to switch off the mains in case of overload of the internal brake resistor (see also: External brake resistor).

Caution!

Unlike previous models of this series, the connector X1 of the supply module does not have to be bridged any more. This connector cannot be used for the monitoring of an external thermal contact and the like! To protect the inverter, wiring according to figure "Wiring using the internal brake resistor" (page 19) is necessary.



4.2.2. Mains and DC-bus monitoring (9210 X3)

At X3 of the power supply module several signals are available, that give information about the status of the mains. The wiring of this terminal is not necessary to make the device work. If the software feature mains failure with DC-bus controlling is required, the terminals X3,1 and X3,3 must be wired. By using an external 24 V supply there is an optoisolated signal of mains failure at terminal X3,5.

For further information see: Parameter setting, page 50.

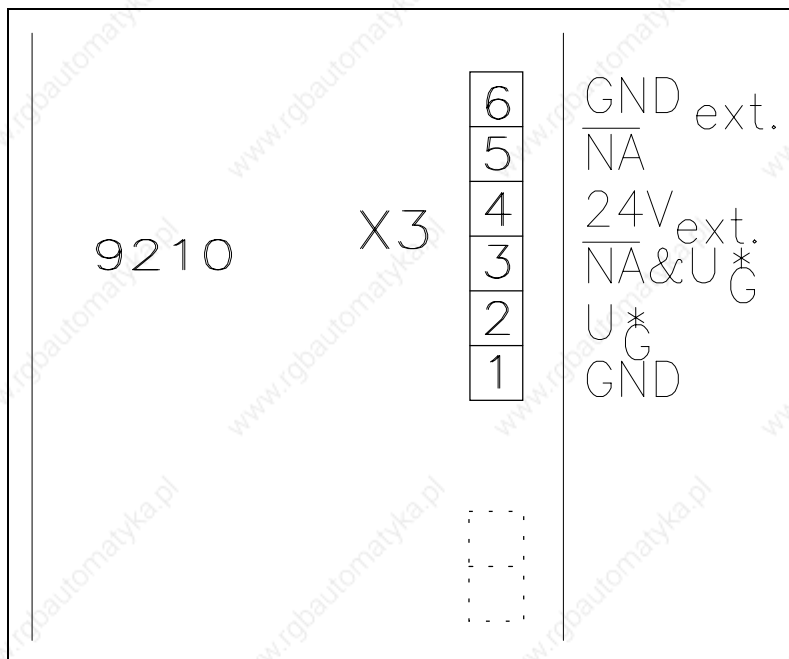

4.2.3. State bus

By means of the state bus X6, the supply module gives status information like ready, overvoltage, and heat sink or resistor overtemperature to the connected axis modules. The four state bus cables must be taken from the supply module to the axis modules. The terminals in the axis module which are next to each other are internally bridged.

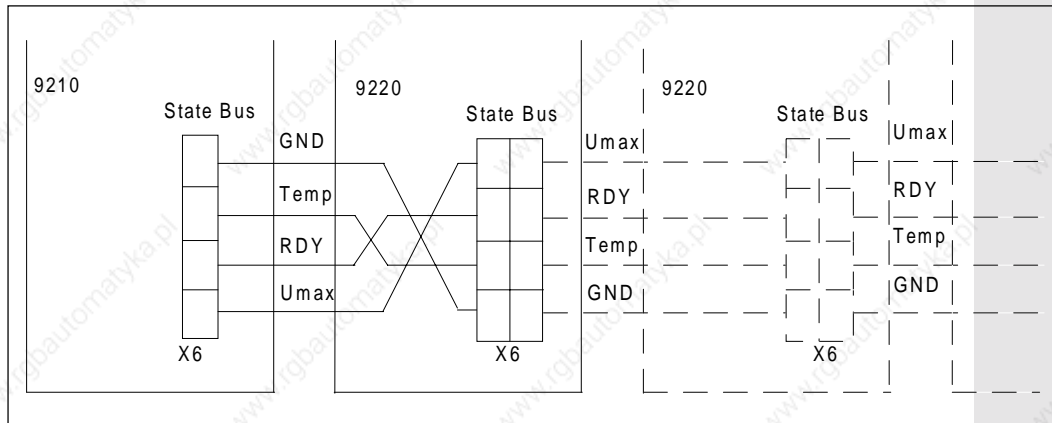

When the modules are ready to operate, the following levels are applied at the terminal of the state bus:

- Temp -> GND : approx. 0...2 V
- RDY -> GND : approx. 0...2 V
- V_{max} GND : more than 2 V

These levels can only be measured when the state bus is connected between the supply module and the axis modules.

4.3. Control connections axis module

4.3.1. Control terminals

Pin assignment of the control terminal block X5

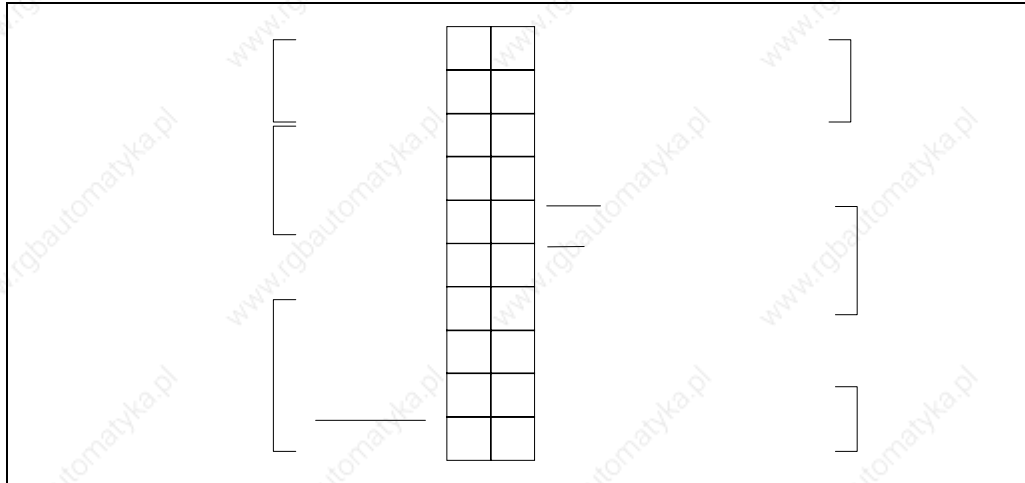

4.3.2. Analog input and outputs

Analog set value selection

For analog set value provision, two inputs are available, either as speed or torque set value provision (for selection see C005 configuration). The bipolar input is a differential input..

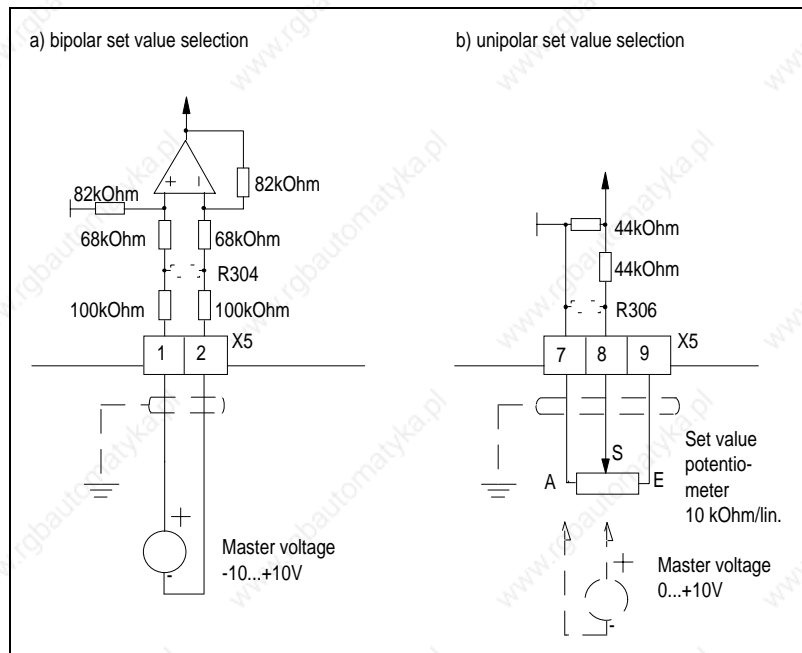

Monitor outputs

The terminals 62 and 63 of the control terminals block X5 transform internal digital control signals into analog output signals. The resolution is 8 bit. The signals are updated every 2ms. The maximum monitor output current capacity is 2mA.

| Output | Terminal | Signal | Range | Level |
|-----------|----------|--------------------|--|-------------|
| Monitor 1 | X 5 62 | Actual speed value | adjustable via C153/C154 | -10V...+10V |
| Monitor 2 | X 5 63 | Torque set value | -M _{max} ...+M _{max} | -10V...+10V |

4.3.3. Digital inputs and outputs

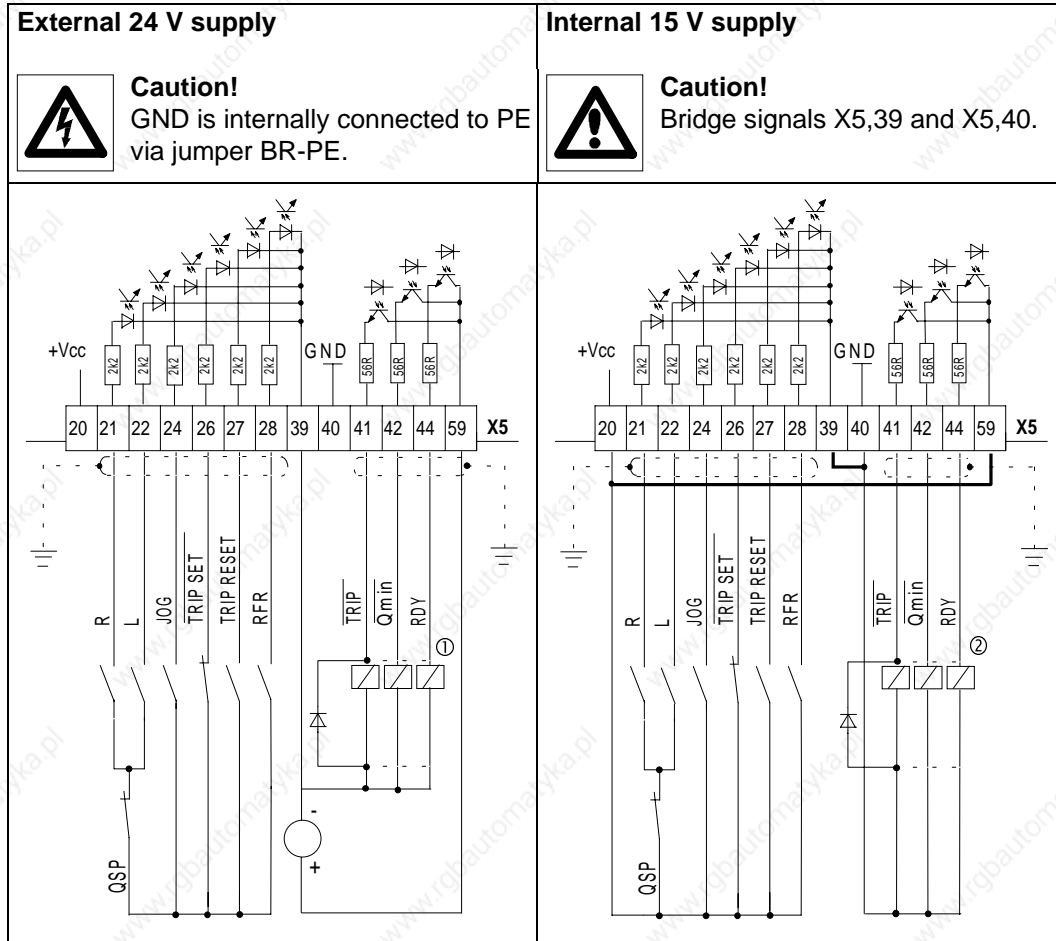

Legend

| | Marking | Function at signal = HIGH |
|--|------------|---|
| Digital outputs I 7 50mA | RDY | Ready |
| | Qmin | Motor speed > value of C017 (factory Setting) The function depends on C117 |
| | TRIP | No faults |
| Digital inputs (active at 13 ... 30 V) I 7 10mA | RFR | Controller enable |
| | TRIP RESET | Fault reset |
| | TRIP SET | No fault switch-off (Motor thermostat) |
| | JOG | Internal set value |
| | QSP | No quick stop with this switch position |
| Relay | ① | Relay 24 V, $R_i \geq 1 \text{ k}\Omega$, e.g. order no. EK00326005 |
| | ② | Relay 15 V, $R_i \geq 600 \Omega$, e.g. order no. EK00326850 |

Comment on QSP function

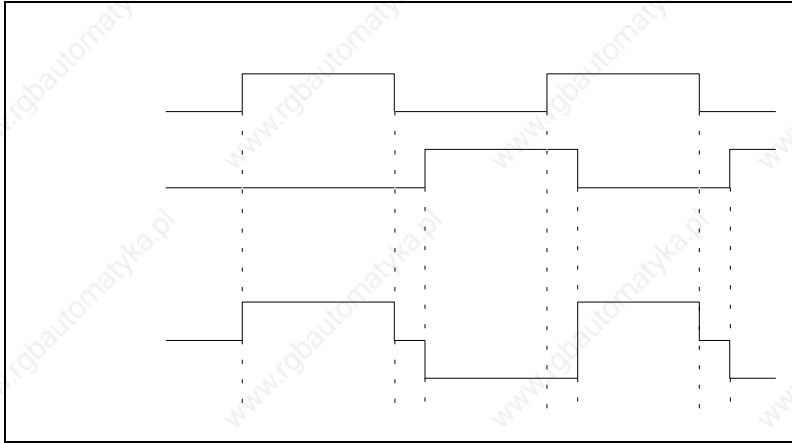

Master frequency selection

For speed set value selection by means of a master frequency, the 9-pole SubD Dig.Set (X2) is used. As master frequency signal either the simulated encoder signal of the master drive or an incremental signal source with two TTL complementary signals shifted by 90° el. can be used. The zero track of the master encoder will not be evaluated. The maximum input frequency is 300 kHz. The current consumption per channel is 6 mA.I.

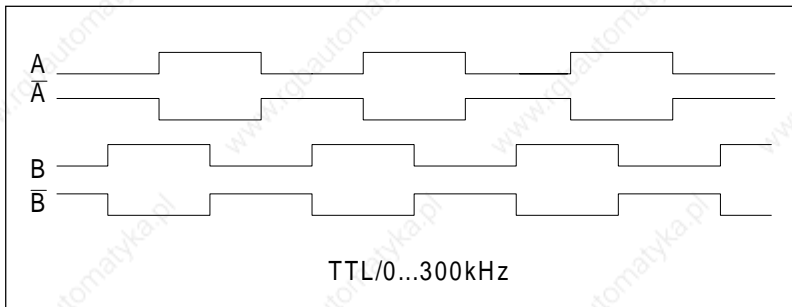

a) Master frequency input by incremental encoder

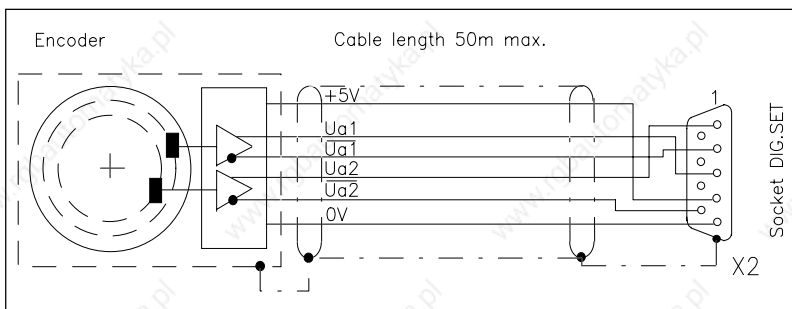

Pin assignment X2 male plug Dig.Set

| Pin | 1 | 2 | 3 | 4 | 5 | 6 | 7 | 8 | 9 |
|--------|----------|----------------|----------|------|-----|----|----|----|----------------|
| Signal | U_{a2} | \bar{U}_{a1} | U_{a1} | + 5V | GND | -- | -- | -- | \bar{U}_{a2} |

b) Master frequency input by encoder output signal of the master drive

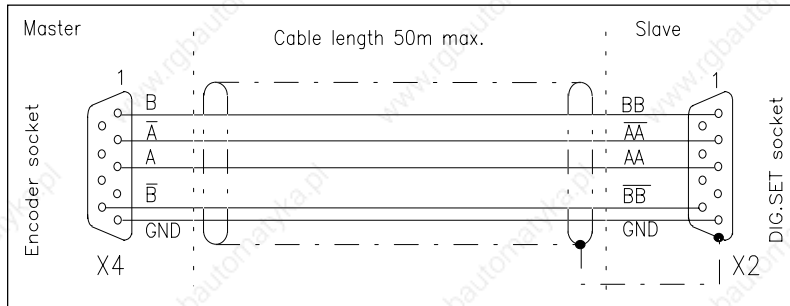

Pin assignment X2 male Dig.Set

| Pin | 1 | 2 | 3 | 4 | 5 | 6 | 7 | 8 | 9 |
|--------|----|-----------------|----|-----|-----|----|----|----|-----------------|
| Signal | BB | \overline{AA} | AA | +5V | GND | -- | -- | -- | \overline{BB} |

Encoder simulation

The encoder socket (X4) is used as an output for the encoder simulation. Two TTL complementary signals ($V_{high} = 2,5V$, $V_{low} = 0,5V$ at $I = 20mA$) shifted by 90° with 256, 512, 1024 or 2048 increments are generated per revolution (adjustable via C030). This output is used for actual value feedback for closed-loop control (positioning control) or as a set value for slaves (master/slave operation). The current capacity is 20 mA per channel.

Pin assignment X4 encoder socket

| Pin | 1 | 2 | 3 | 4 | 5 | 6 | 7 | 8 | 9 |
|--------|---|----------------|---|-----|-----|----------------|---|----|----------------|
| Signal | B | \overline{A} | A | +5V | GND | \overline{Z} | Z | LC | \overline{B} |

Resolver

2-pole resolvers ($V=10V, f=5kHz$) are fitted as standard. The Lenze servo motors are already equipped with the corresponding resolvers. The resolver is connected by means of a 9-pole socket (X3). The resolver supply cable and the resolver are monitored for open circuit (fault indication Sd2).

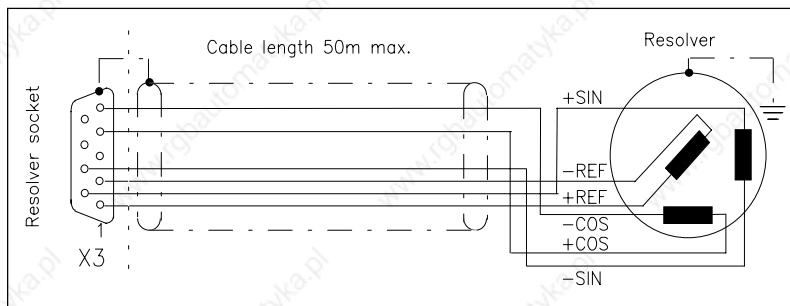

Pin assignment X3 resolver female plug

| Pin | 1 | 2 | 3 | 4 | 5 | 6 | 7 | 8 | 9 |
|--------|------|------|-----|------|------|------|------|----|----|
| Signal | +REF | -REF | GND | +COS | -COS | +SIN | -SIN | -- | -- |

5. Application examples

5.1. Variant with integrated positioning module 2211PP

Easy positioning tasks can be solved by applying the positioning module 2211PP. Thus, you sometimes do not need a PLC or at least reduce the load of the PLC. The positioning module can be integrated into the unit and adapted to several applications. Different designs are available, e.g. the basic module with or without a terminal extension and alternatively a field bus module as Interbus-S.

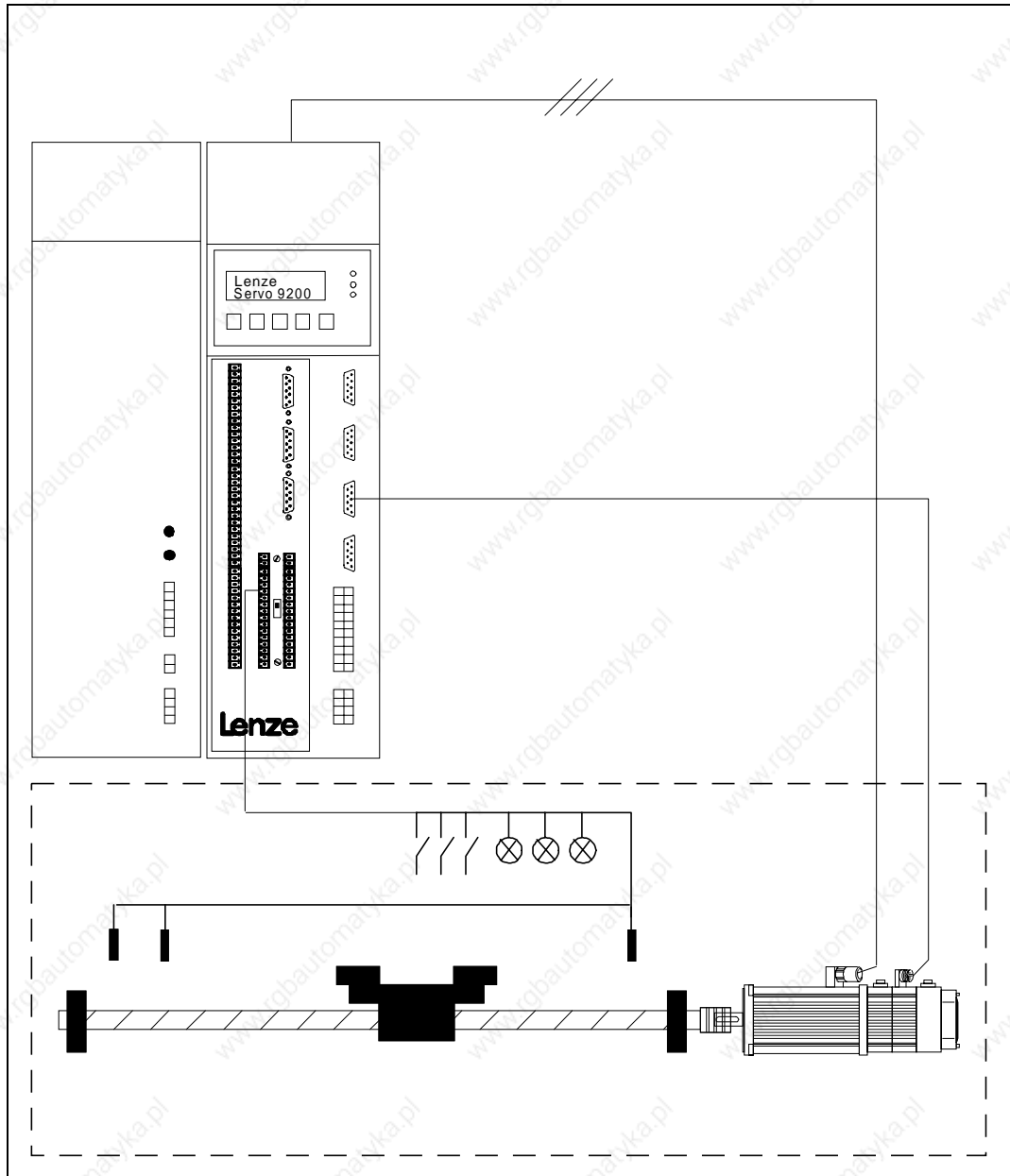

Features of the positioning module 2211PP:

- 32 freely assignable digital inputs with 8 or 28 via terminals according to variant
- 32 freely assignable digital outputs with 4 or 16 via terminals according to variant
- Absolute or relative measuring system
- 32 program sets, each with the following functions:
 - point to point positioning
 - point to point positioning with velocity profile
 - positioning to an interrupt-input
 - acceleration, deceleration, traversing and final speed adjustable
 - waiting for input
 - switching of several outputs
 - homing according to 6 different modes
 - adjustable waiting time
 - adjustable number of pieces for repeat function
 - program branching depending on inputs
 - jump to following program set
- 32 adjustable positions
- 32 adjustable speeds
- 32 adjustable acceleration and deceleration values
- 32 adjustable number of pieces
- 32 waiting time
- Manual and program operation
- Input and display via the operating unit of the 9200 basic unit
- Parameter setting and programming via the serial interface LECOM A/B of the basic unit by means of the PC program Lemoc2 (via menu)
- Connection of a BCD switch possible
- Connection of an absolute encoder possible
- Control, parameter setting, and programming via Interbus-S or Profibus possible
- The function Winding calculator is available as alternative system software on the same hardware basis as the positioning module.

**Note:**

Please additionally note the Operating Instructions of the positioning system.

5.2. Wiring with positioning control SX-1

5.2.1. Diagram 1: Mains supply

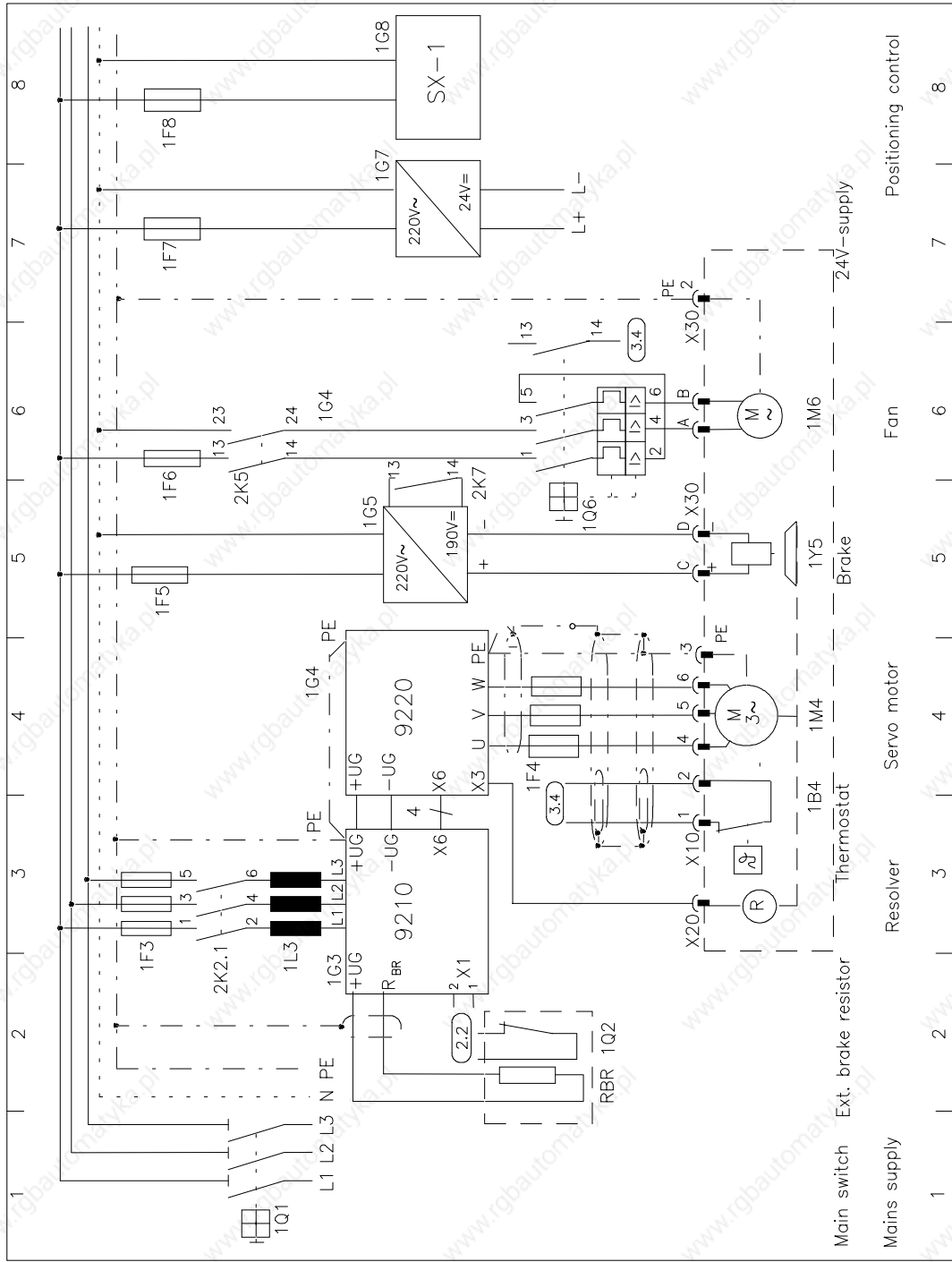

5.2.2. Diagram 2: Control circuit 230V

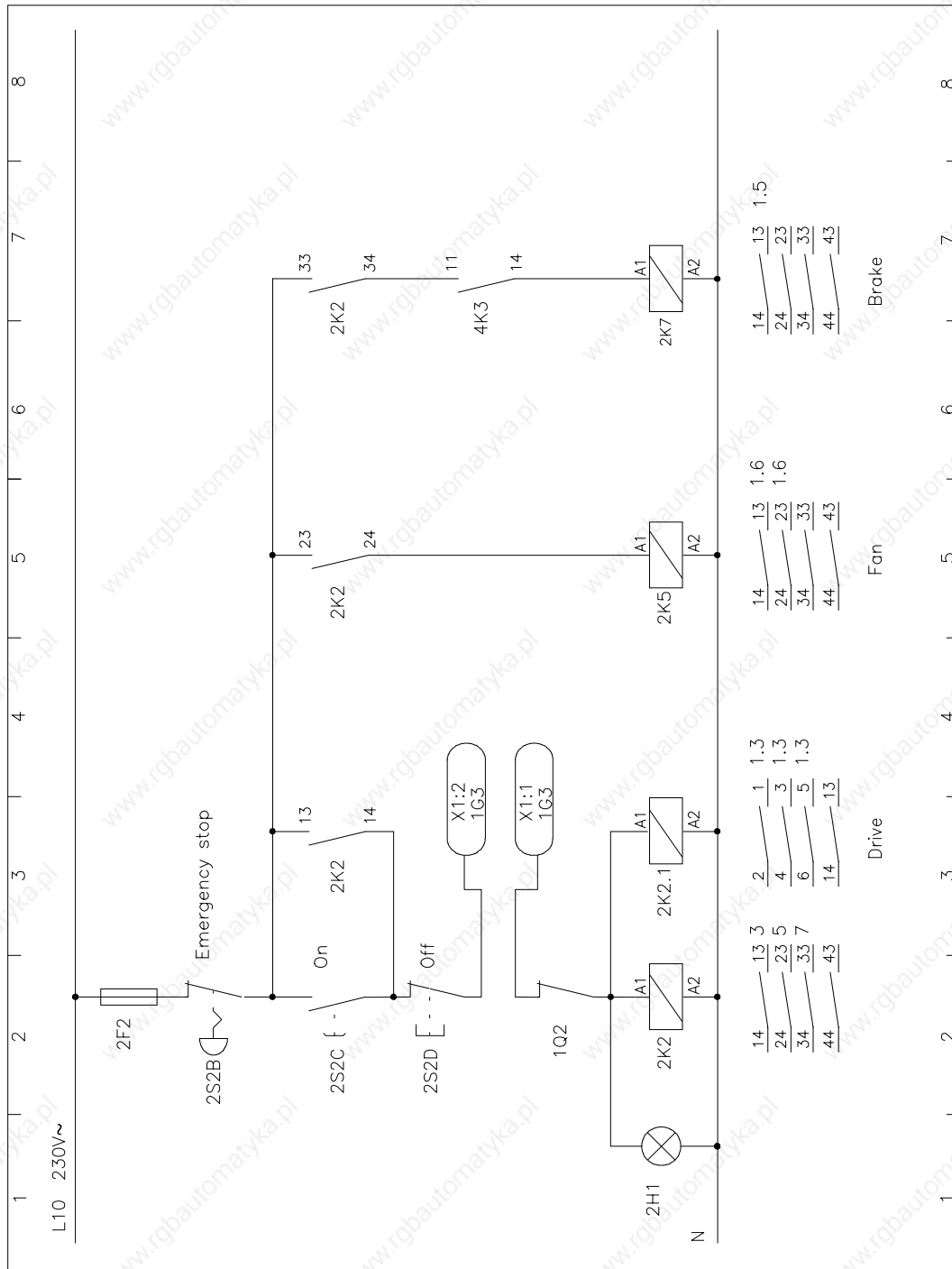

5.2.3. Diagram 3: Control circuit 24V

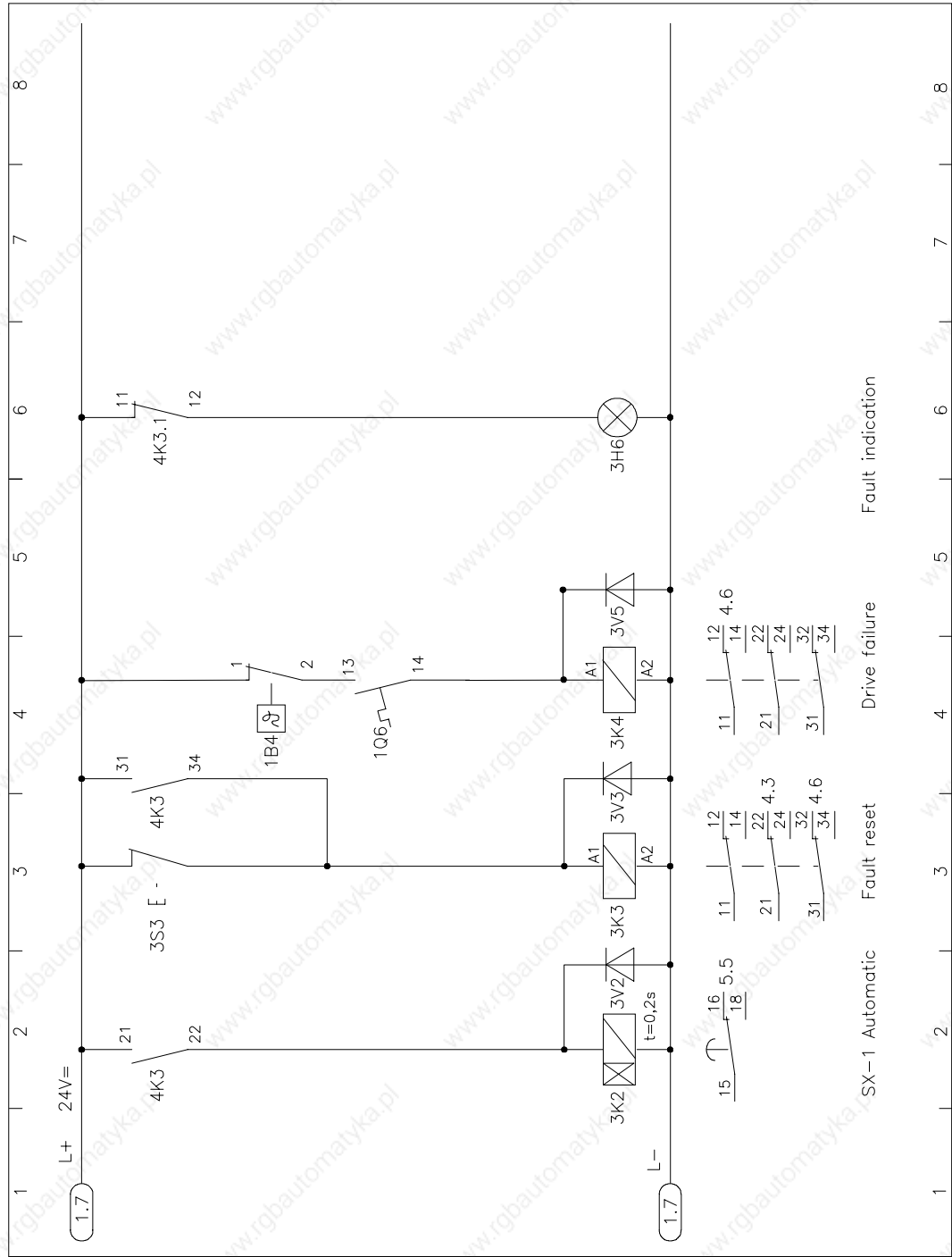

5.2.4. Diagram 4: Control connections 9200 - SX1

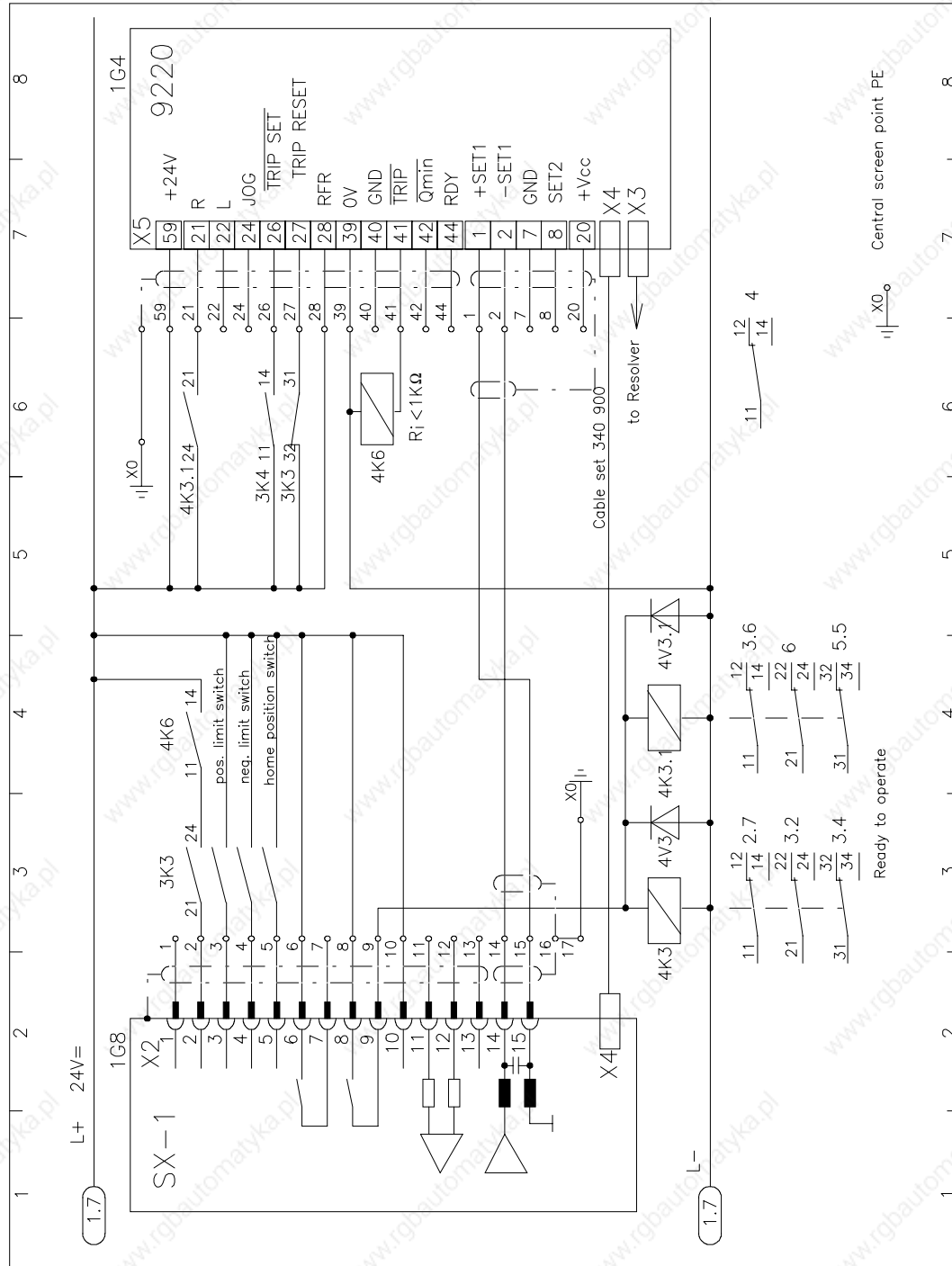

5.2.5. Diagram 5: Control connections SX1

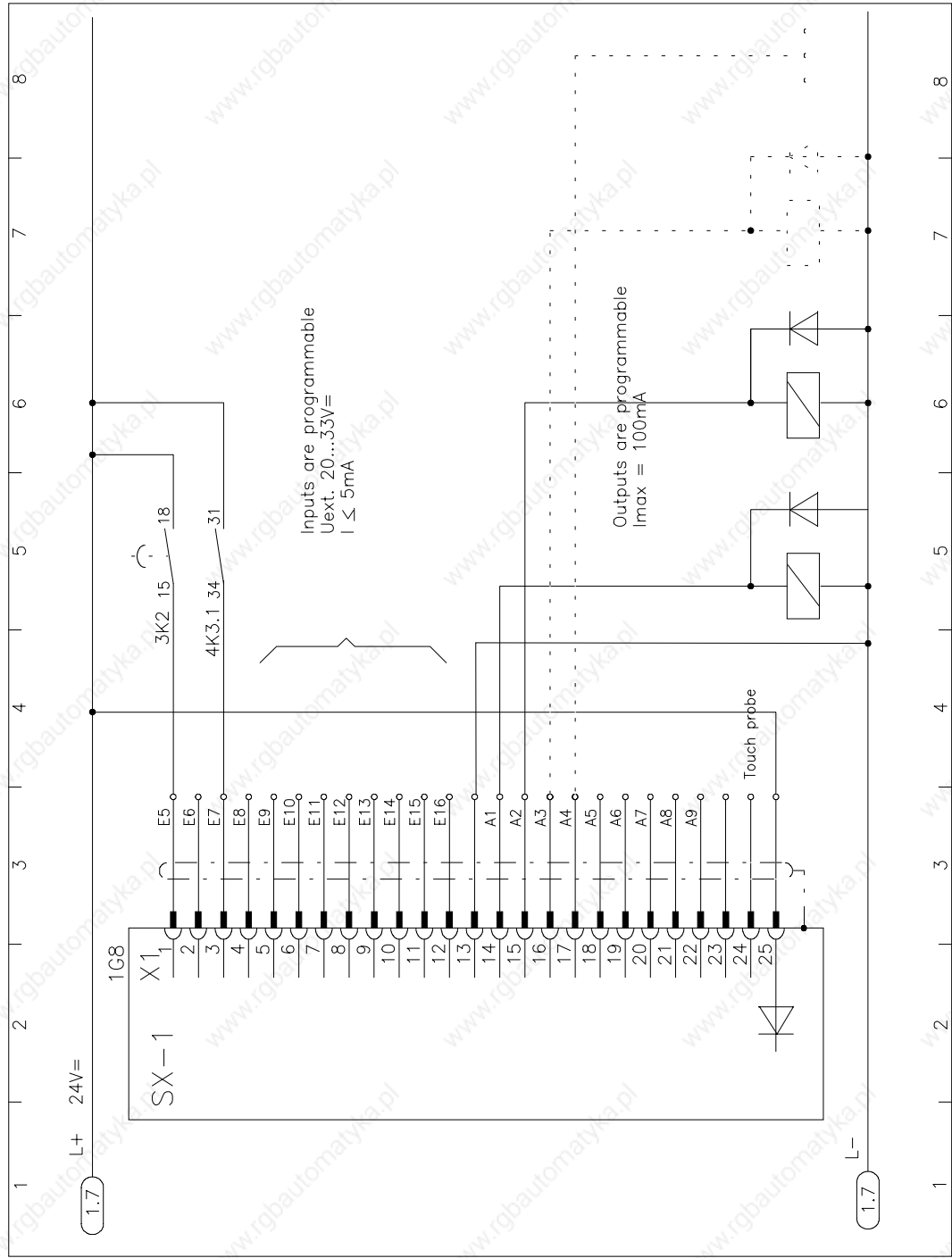

6. Accessories

(All listed components must be ordered separately)

6.1. External brake resistors

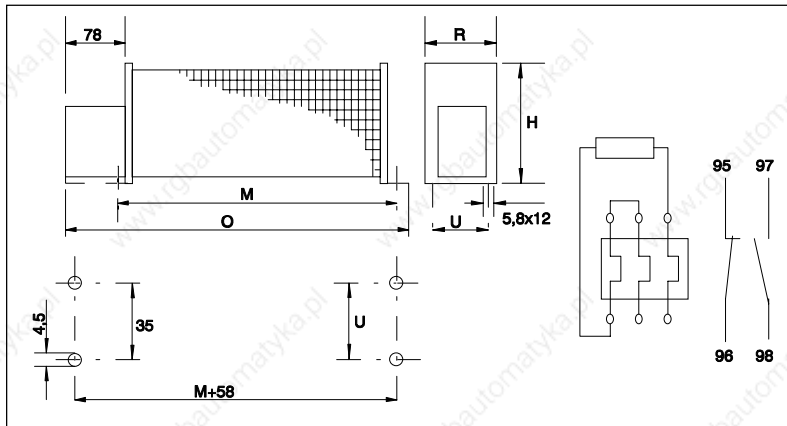

| | R [Ω] | Pn [kW] | Order no. | H [mm] | M [mm] | O [mm] | R [mm] | U [mm] |
|------|----------|------------|--------------|-----------|-----------|-----------|-----------|-----------|
| 9212 | 29 | 1,1 | ERBD029R01k1 | 120 | 430 | 510 | 92 | 64 |
| 9215 | 11 | 1,1 | ERBD011R01k1 | 120 | 430 | 510 | 92 | 64 |
| 9217 | 8,5 | 1,1 | ERBD009R01k1 | 120 | 430 | 510 | 95 | 64 |

6.2. Mains chokes

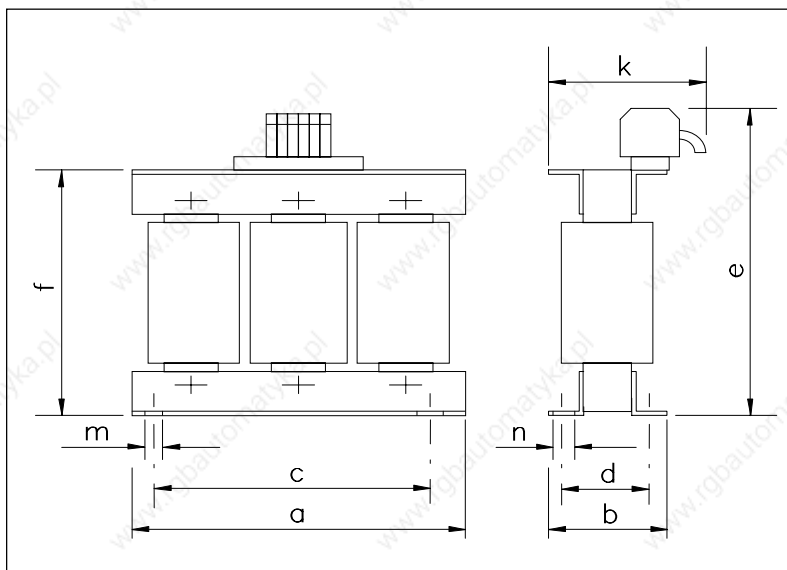

| | L [mH] | I [A] | Part no. | a [mm] | b [mm] | c [mm] | d [mm] | e [mm] | f [mm] | k [mm] | m [mm] | n [mm] |
|------|-----------|----------|---------------|-----------|-----------|-----------|-----------|-----------|-----------|-----------|-----------|-----------|
| 9212 | 3 x 2,5 | 3 x 7 | ELN3_0250H007 | 120 | 61 | 84 | 45 | 130 | 105 | 73 | 6.0 | 11 |
| 9215 | 3 x 1,2 | 3 x 25 | ELN3_0120H025 | 150 | 76 | 140 | 61 | 180 | 140 | 95 | 5.0 | 10 |
| 9217 | 3 x 0,75 | 3 x 45 | ELN3_0075H045 | 180 | 91 | 161 | 74 | 225 | 165 | 120 | 6.3 | 11 |

6.3. RFI filter

For radio interference suppression according to EN 55011, limit value class A or B.

Assigned RFI filters for mains voltage of 400 V

| Supply module type | 9212 | 9215 | 9217 |
|--------------------------|--------------|--------------|--------------|
| Mains current RFI filter | 8 A | 25 A | 50 A |
| Order no. mains filter | EZF3_008A001 | EZF3_025A001 | EZF3_050A004 |

Filter for mains voltages of up to 460 V: please contact manufacturer

6.4. External fuses

Semiconductor protection

External fast acting fuses in the mains input protect the input rectifier in the supply module.

Recommended semiconductor protection fuses (at mains side):

| Supply module | 9212 | 9215 | 9217 |
|---------------------------------------|-----------------------------|-----------------------------|------------------------------|
| Mains input with rectifier protection | FF 20A / 700V 14 x 51 | FF 63A / 700V 22 x 58 | FF 100A / 700V 22 x 58 |
| Order no. | EFSFF0200ARH | EFSFF0630ARI | EFSFF1000ARI |

Input cables must be protected with standard fuses adapted to the cross-sectional area of the cables.

6.5. System cables

Note

For best interference immunity results, cut the cables to the required length.

Fehler! Es ist nicht möglich, durch die

6.5.1. System cables for control terminal block X5

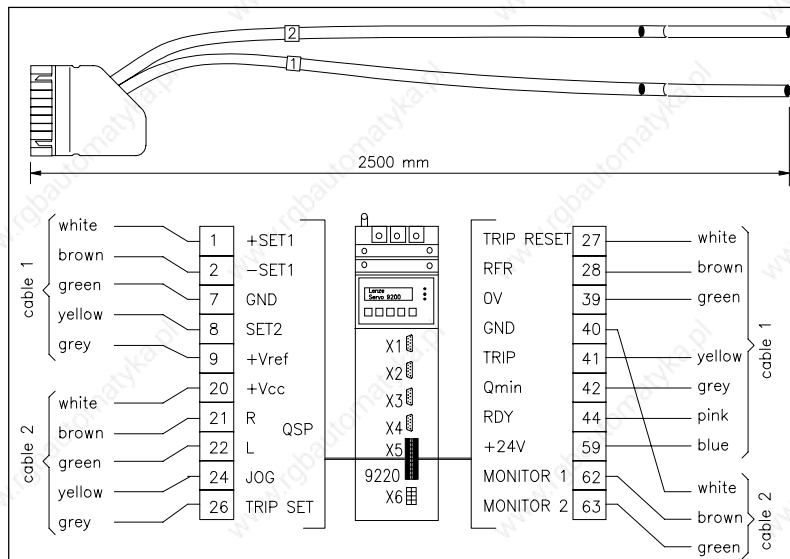

| Design for | left X5 terminals | right X5 terminals |
|------------|-------------------|--------------------|
| Order no. | EW00340899 | EW00340898 |

6.5.2. System cables for master frequency selection X2 and incremental encoder output X4

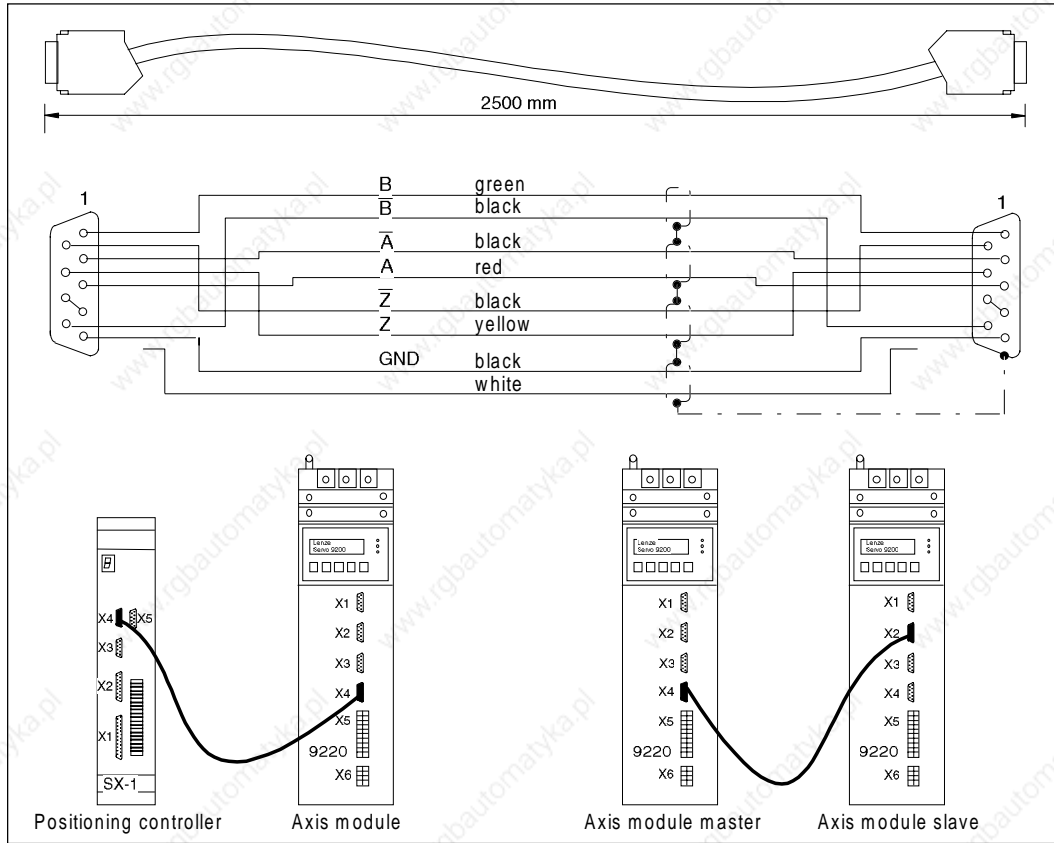

| Design | with plugs at both ends | with single plug |
|-----------|-------------------------|------------------|
| Order no. | EW00340900 | EW00340906 |

Fehler! Es Note:

ist nicht möglich, durch die The bridge between pin 4 and pin 8 is necessary for the operation with the SX1 positioning control.

6.5.3. System cables for resolver X3

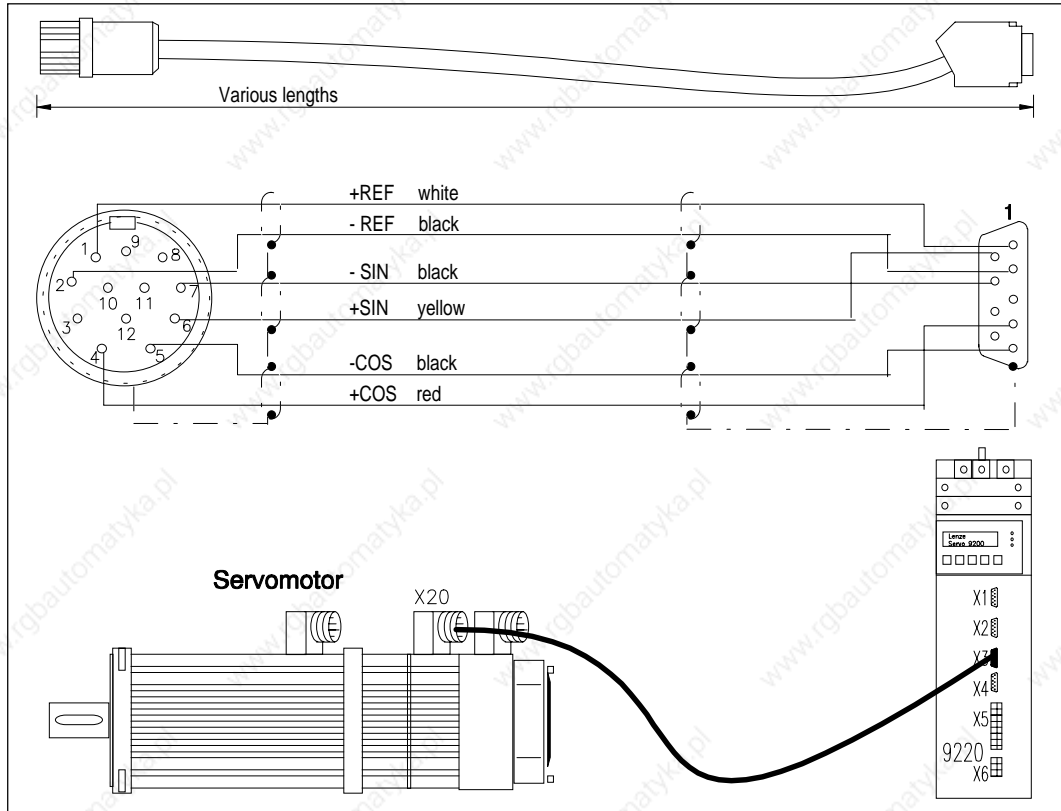

Order numbers of resolver cables

| Length | plugs at both ends | plug at motor side | plug at unit side |
|--------|--------------------|--------------------|-------------------|
| 2.5 m | - | - | EW00340907 |
| 5 m | EWREB____05 | EW00345891 | - |
| 10 m | EWREB____10 | EW00340909 | - |
| 15 m | EWREB____15 | EW00345892 | - |
| 20 m | EWREB____20 | EW00345893 | - |
| 25 m | EWREB____25 | EW00345894 | - |
| 30 m | EWREB____30 | EW00345895 | - |
| 35 m | EWREB____35 | EW00345896 | - |
| 40 m | EWREB____40 | EW00345897 | - |
| 45 m | EWREB____45 | EW00345898 | - |
| 50 m | EWREB____50 | EW00345899 | - |

6.5.4. System cables for power supply of servo motors

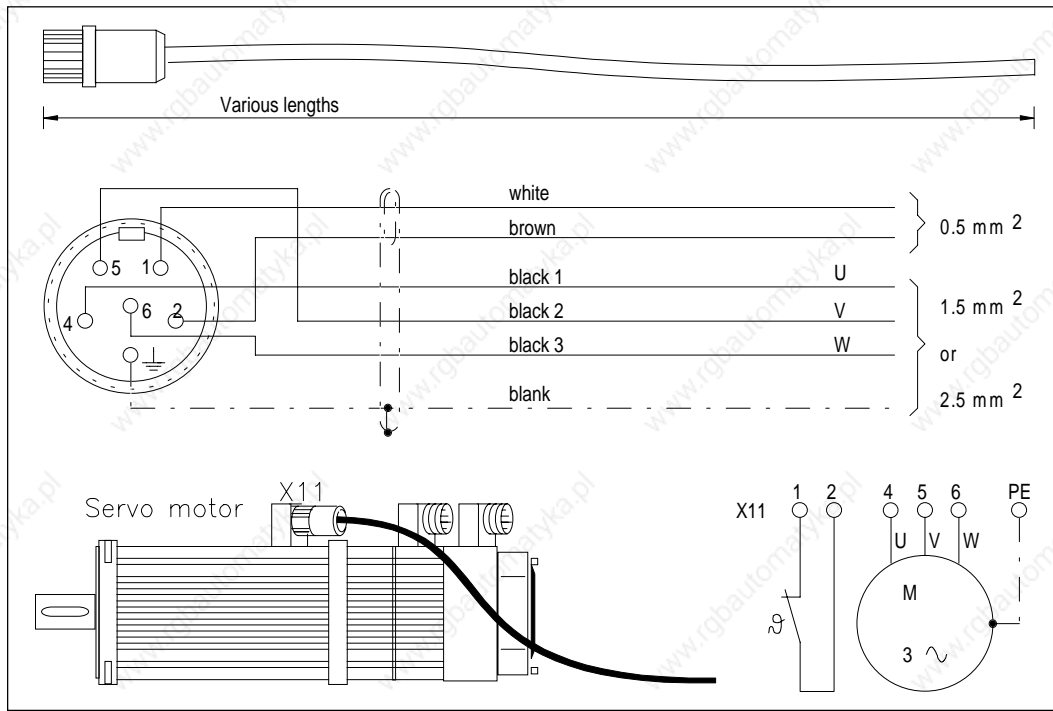

Order numbers of motor cables

| Length | Cable cross section | | | |
|--------|--|--|--|---|
| | 4 x 1.5 mm ² 2 x 0.5 mm ² | 4 x 2.5 mm ² 2 x 0.5 mm ² | 4 x 4.0 mm ² 2 x 0.5 mm ² | 4 x 10 mm ² 2 x 0.5 mm ² |
| 5 m | EWMOL056_01505 | EWMOL056_02505 | EWMOL100_04005 | EWMOL112_10005 |
| 10 m | EWMOL056_01510 | EWMOL056_02510 | EWMOL100_04010 | EWMOL112_10010 |
| 15 m | EWMOL056_01515 | EWMOL056_02515 | EWMOL100_04015 | EWMOL112_10015 |
| 20 m | EWMOL056_01520 | EWMOL056_02520 | EWMOL100_04020 | EWMOL112_10020 |
| 25 m | EWMOL056_01525 | EWMOL056_02525 | EWMOL100_04025 | EWMOL112_10025 |
| 30 m | EWMOL056_01530 | EWMOL056_02530 | EWMOL100_04030 | EWMOL112_10030 |
| 35 m | EWMOL056_01535 | EWMOL056_02535 | EWMOL100_04035 | EWMOL112_10035 |
| 40 m | EWMOL056_01540 | EWMOL056_02540 | EWMOL100_04040 | EWMOL112_10040 |
| 45 m | EWMOL056_01545 | EWMOL056_02545 | EWMOL100_04045 | EWMOL112_10045 |
| 50 m | EWMOL056_01550 | EWMOL056_02550 | EWMOL100_04050 | EWMOL112_10050 |

6.5.5. System cables for supply for fan and brake

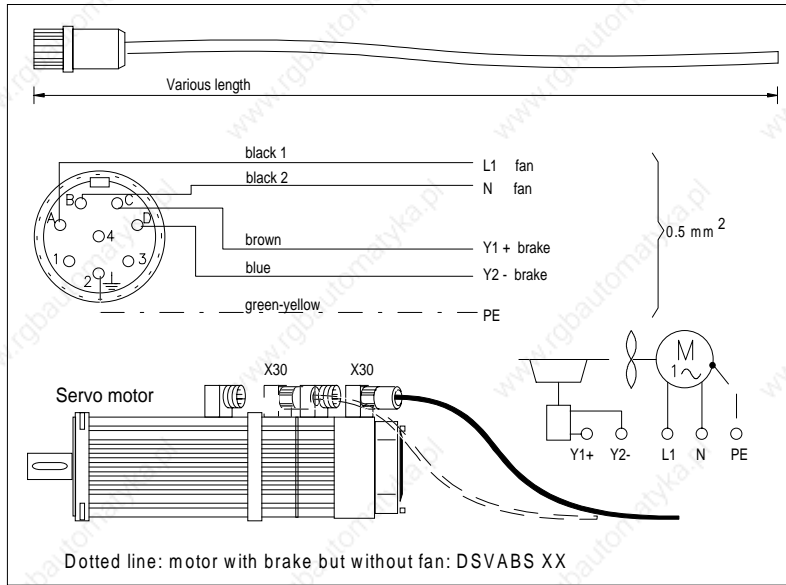

Order numbers of fan and brake supply cables

| Length | Cable cross section |
|--------|-------------------------------|
| | 5 x 0.5 mm² |
| 5 m | EWBLL 05 |
| 10 m | EWBLL 10 |
| 15 m | EWBLL 15 |
| 20 m | EWBLL 20 |
| 25 m | EWBLL 25 |
| 30 m | EWBLL 30 |
| 35 m | EWBLL 35 |
| 40 m | EWBLL 40 |
| 45 m | EWBLL 45 |
| 50 m | EWBLL 50 |

6.6. Motors

Asynchronous servo motors DSV/DFV series

| Motor type | Technical data of motors | | | | | | | | | Standstill brake $V_n = 205 V =$ | | Fan 230V~ 50/60Hz |
|-------------------|-------------------------------|---------------|---------------|------------------|--------------|---------------|----------------|---------------------------|-----------|-------------------------------------|--------------|-------------------------|
| | n_n [min ⁻¹] | M_n [Nm] | P_n [kW] | V_{n3-} [V] | I_n [A] | f_n [Hz] | $\cos \varphi$ | J [kgcm ²] | m [kg] | M_n [Nm] | I_n [A] | I_n [A] |
| DSVARS 56 | 3950 | 2.0 | 0.8 | 390 | 2.4 | 140 | 0.70 | 2.6 | 6.4 | -- | -- | -- |
| DSVABS 56 | 3950 | 2.0 | 0.8 | 390 | 2.4 | 140 | 0.70 | 3.0 | 6.9 | 2.5 | 0.06 | -- |
| DSVARS 71 | 4050 | 4.0 | 1.7 | 390 | 4.4 | 140 | 0.76 | 5.8 | 10.4 | -- | -- | -- |
| DSVABS 71 | 4050 | 4.0 | 1.7 | 390 | 4.4 | 140 | 0.76 | 6.8 | 11.2 | 11.0 | 0.08 | -- |
| DFVARS 71 | 3410 | 6.3 | 2.2 | 390 | 6.0 | 120 | 0.75 | 5.8 | 12.0 | -- | -- | 0.12 |
| DFVABS 71 | 3410 | 6.3 | 2.2 | 390 | 6.0 | 120 | 0.75 | 6.8 | 12.9 | 11.0 | 0.08 | 0.12 |
| DSVARS 80 | 4100 | 5.4 | 2.3 | 390 | 5.8 | 140 | 0.75 | 19.2 | 15.1 | -- | -- | -- |
| DSVABS 80 | 4100 | 5.4 | 2.3 | 390 | 5.8 | 140 | 0.75 | 23.0 | 16.9 | 12.0 | 0.09 | -- |
| DFVARS 80 | 3455 | 10.8 | 3.9 | 390 | 9.1 | 120 | 0.80 | 19.2 | 16.9 | -- | -- | 0.12 |
| DFVABS 80 | 3455 | 10.8 | 3.9 | 390 | 9.1 | 120 | 0.80 | 23.0 | 18.7 | 12.0 | 0.09 | 0.12 |
| DSVARS 90 | 4110 | 9.5 | 4.1 | 350 | 10.2 | 140 | 0.80 | 36.0 | 22.9 | -- | -- | -- |
| DSVABS 90 | 4110 | 9.5 | 4.1 | 350 | 10.2 | 140 | 0.80 | 40.0 | 25.0 | 22.0 | 0.09 | -- |
| DFVARS 90 | 3480 | 19.0 | 6.9 | 390 | 15.8 | 120 | 0.80 | 36.0 | 25.5 | -- | -- | 0.25 |
| DFVABS 90 | 3480 | 19.0 | 6.9 | 390 | 15.8 | 120 | 0.80 | 40.0 | 27.1 | 22.0 | 0.09 | 0.25 |
| DSVARS 100 | 4150 | 12.0 | 5.2 | 330 | 14.0 | 140 | 0.78 | 72.0 | 44.7 | -- | -- | -- |
| DSVABS 100 | 4150 | 12.0 | 5.2 | 330 | 14.0 | 140 | 0.78 | 81.5 | 47.4 | 40.0 | 0.11 | -- |
| DFVARS 100 | 3510 | 36.0 | 13.2 | 390 | 28.7 | 120 | 0.80 | 72.0 | 48.2 | -- | -- | 0.25 |
| DFVABS 100 | 3510 | 36.0 | 13.2 | 390 | 28.7 | 120 | 0.80 | 81.5 | 50.9 | 40.0 | 0.11 | 0.25 |
| DSVARS 112 | 4160 | 17.0 | 7.4 | 320 | 19.8 | 140 | 0.80 | 180.0 | 60.0 | -- | -- | -- |
| DSVABS 112 | 4160 | 17.0 | 7.4 | 320 | 19.8 | 140 | 0.80 | 212.0 | 66.5 | 80.0 | 0.18 | -- |
| DFVARS 112 | 3520 | 55.0 | 20.3 | 390 | 42.5 | 120 | 0.80 | 180.0 | 63.5 | -- | -- | 0.24 |
| DFVABS 112 | 3520 | 55.0 | 20.3 | 390 | 42.5 | 120 | 0.80 | 212.0 | 70.0 | 80.0 | 0.18 | 0.24 |

For further information about servo motors please see the operating Instructions "Three-phase servo motors".

Parameter setting

1. LCD display

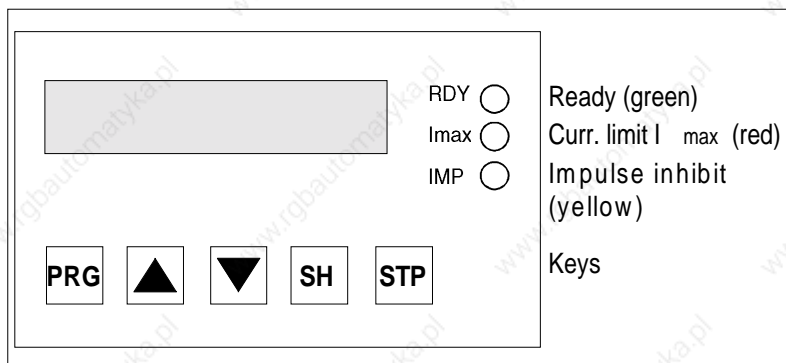

1.1. Key functions

| Key | Function |
|----------|--|
| PRG | Change between code and parameter level |
| ▲ | Increase displayed value |
| ▲ + SH | Rapid increase of displayed value |
| ▼ | Reduce displayed value |
| ▼ + SH | Rapid reduction of displayed value |
| SH + PRG | Execute change. Reset after fault indication |
| STP | Inhibit controller (see note below) |
| SH + STP | Enable controller |

Note

- For the execution command SH+PRG and the enable command SH+STP first press the SH key and hold, than press the PRG or STP key.
- When inhibiting the controller by pressing the STP key, it must be enabled again by using the SH+STP command. Only then can it be enabled via terminal 28 or interface.

Fehler! Es ist nicht möglich, durch die

1.2. Plain-text display

The LCD display consists of two lines of 16 characters each. In the upper line, code no. and parameter are displayed. The arrow > shows the present level (code or parameter level), which can be changed when pressing the ▲ or ▼ key. In the lower line, the codes or parameters are explained.

-Arrow for code level-

↓ -Code no.- -Parameter-

| | | | | | | | | | | | | | | | |
|---|---|---|---|---|---|---|---|---|---|---|---|---|---|--|--|
| > | C | 0 | 0 | 1 | | | - | 0 | - | | | | | | |
| O | p | e | r | a | t | i | n | g | | m | o | d | e | | |

-Explanatory text-

2. Basics of parameter setting

The drive can be adapted to your specific applications by parameter setting of the axis modules. The possible settings are arranged in the form of codes, which are numbered in ascending order and start with the letter "C". Each code provides several parameters which can be selected according to the application.

Parameters can be direct values of a physical unit (e.g. 50Hz or 50% related to f_{dmax}) or numerical codes giving certain status information (e.g. -0- = controller inhibited, -1- = controller enabled). In cases where the parameters represent values of physical units, it is possible to vary the increment.

Example: The acceleration and deceleration can be set in increments of 0.01 s up to 1 s and in increments of 0.1 s from 1 s upwards.

For codes with more than 5 digit values, the keypad operation is different: In the parameter level, the cursor can be shifted to enter large values. This is done by pressing SH+ ▲ and SH+ ▼ (see example on page 44).

In some codes, parameters can only be read but not changed. In the factory setting, only those codes are displayed which are necessary for the most common applications. For activation of the extended code set see code table C 000.

2.1. Change parameters

Each code has a factory set parameter which can be changed. There are three different ways of selecting and confirming a new parameter, depending on the code:

Direct acceptance

The servo axis immediately accepts the new parameter, i.e. while you change it using the ▲ or ▼-key. This is possible even when the drive is running. Parameters which are immediately accepted are marked with **ON-LINE** in the code table.

Acceptance with SH + PRG

The axis accepts a new parameter when SH + PRG are pressed. This is possible even with the drive running. First press SH and then in addition PRG. The display shows --ok-- for 0.5 seconds. The axis module now works with the new parameter. The key combination SH and PRG can be compared to the "return" key on your computer keyboard. If you have to set a parameter of a code in this way, the code table shows the symbol **SH + PRG**.

Acceptance with SH + PRG with controller inhibit

The axis module accepts the new parameter when it has been inhibited prior to pressing SH + PRG. Inhibit the controller e.g. by pressing STP. First press SH and then in addition PRG. The display shows --ok-- for 0.5 seconds. The axis module works with the new parameter when the controller is released again. If you have to set a parameter of a code in this way, the symbol  appears in the code table.

2.2. Save parameters

- When commissioning for the first time, the parameter set 1 is factory-set. After the acceptance, new parameters are saved in the RAM, i.e. they are saved until the controller is disconnected from the mains.

If you do not want to lose your setting when connecting the controller to the mains, save them permanently:

1. Select code C003.
2. Select parameter set 1 by entering -1- .
3. Press SH first, and then additionally PRG. --ok-- will be displayed.
4. Now you can disconnect the servo controller from the mains.
Your settings are permanently saved under "parameter set 1".

- **Password**

The input of a password prevents unauthorized changes of parameters or code levels.

2.3. Load parameter

If you only need one parameter set, you can permanently save your changes under parameter set 1. After every mains connection, parameter set 1 is loaded automatically.

2.4. Examples

Change of the operating mode

1. enter Code C001 using ▲ or ▼ keys

-Arrow for code level-

↓ -Code no.- -parameter-

| | | | | | | | | | | | | | | |
|---|---|---|---|---|---|---|---|---|---|---|---|---|---|--|
| > | C | 0 | 0 | 1 | | | - | 0 | - | | | | | |
| O | p | e | r | a | t | i | n | g | | m | o | d | e | |

-Explanatory text-

2. change from code level to parameter level using the PRG key

-Arrow for parameter level-



| | | | | | | | | | | | | | | |
|---|---|---|---|---|---|---|---|---|---|---|---|---|---|---|
| | C | 0 | 0 | 1 | > | | - | 0 | - | | | | | |
| T | e | r | m | i | n | a | l | / | k | e | y | p | a | d |

-explanatory text for the selected parameter-

3. set parameter to -1- using the ▲ key

| | | | | | | | | | | | | | | |
|--|---|---|---|---|---|--|---|---|---|---|---|---|--|--|
| | C | 0 | 0 | 1 | > | | - | 1 | - | | | | | |
| | | | | | | | k | e | y | p | a | d | | |

4. acknowledge with the keys SH + PRG and return to code level

| | | | | | | | | | | | | | | |
|---|---|---|---|---|---|---|---|---|---|---|---|---|---|--|
| | C | 0 | 0 | 1 | > | | - | 1 | - | | | | | |
| O | p | e | r | a | t | i | n | g | | m | o | d | e | |

3. Commissioning

The following notes on the commissioning do not explain all possibilities of parameter settings. The code table at the end of the chapter lists and describes all codes in detail.



Caution!

Before commissioning, check the wiring of the controller.

Typical faults are:

- incorrect screening of the cables
- earth or ground current loops

and if Lenze system cables are not used:

- incorrect connection of the motor phases
- incorrect connection of the resolver terminals

The axis modules are factory-set for terminal control and parameter setting via keypad for speed control with asynchronous motor, resolver feedback and analog set value provision at terminal 8 (C005 = 11). For this standard application, the basic parameters are already programmed. Start entering the motor nameplate data (see page 47) for commissioning.

For all other applications, the basic parameters must be selected.

3.1. Basic parameter setting

Before setting the parameters of the axis module, the controller must be inhibited, i.e. terminal 28 open, RFR ENABLE switch open, or STP key pressed.

- **C000 code set**

All codes in the inverter are arranged in different code sets. With factory setting, the standard code set is activated. It contains all codes which are required for the most common applications.

By selecting the extended code set under code C000, the keypad also shows those codes which are suitable for special applications. There is also a service code set which is not accessible in general.

If you want to protect your parameter settings from non-authorized access you can enter a password in the form of a three-digit number. By defining a password, the parameters of the standard code set can only be read, but not changed when the password is not entered. The parameters of the extended code set can neither be read nor changed.

First enter the password under C094 and then set code C000 to "standard code set read only". After this, the setting of code C000 can only be changed when the programmed password is entered.

- **C001 Operating mode**

Selection between keypad control or control via LECOM-A/B interface or parameter setting via LECOM interface. For control or parameter setting via LECOM interface, the drive must, in addition, be given an address in code C009 (code set -2-).

To change the operating mode, open RFR switch (X5 terminal 28 open). The functions RFR ENABLE, QSP, Trip set and Trip reset are not affected and can be controlled via terminals.

After selecting the control via Lecom (C001 = 3, 5, 6, 7) the controller must be enabled via the selected interface. If Lecom1 control (C001 = 3) has been selected, although the interface is not connected, the controller can be enabled again by selecting C001 = 1, and then C040 = 1. If LECOM 2 control has been selected (C001 = 5, 6, 7) if the interface is not connected, the controller remains inhibited even after changing C001. To enable the controller again, select under C001 a parameter other than 5, 6, 7 save the parameter and disconnect the controller from the mains. After reconnection, the controller can be enabled again.

- **C005 Configuration**

Other control modes (e.g. torque control) or alternative methods of producing the reference signal are available. The configuration can only be changed whilst in code set -2-.

Caution!

When changing the configuration, control structure, motor and encoder and terminal assignment are changed.



- **C025 Encoder**

The set value and the actual value encoder can be selected under C025 (PPR). Encoder constants are set under C026. The master/slave ratio is set under C027.

- **Master frequency Dig.Set**

The master frequency provision is set under C025 -3- via input Dig.Set (X2); then the increments per revolution are set in code C026. It is also possible to set the speed ratio between the master and slave, this adjustment is made under code C027.

Under **C028**, a second ratio can be entered.

Under **C140**, the required speed ratio is activated.

Another possibility to set the angular synchronization is given by the gearbox factor. The gearbox factor is given as a fraction. The numerator of the fraction is entered under **C032**, and the denominator of the fraction is entered under **C033**.

Beispiel:

given: $f_{\text{DIG.SET}_{\text{max}}} = 100 \text{ kHz}$
 $n_{\text{max}} = 3000 \text{ rpm}$

required: encoder constant C026
encoder setting C027

100 kHz = 100.000 increments/s

3000 rpm = 50 rps

$$C026 = \frac{100.000 \text{ increments / s}}{50 / \text{s}} = 2000 \text{ increments/revolution}$$

Selectable are 512, 1024, 2048, 4096 increments/revolution

C026 = 2048 is chosen

C027 = 2048/2000 = 1,024

C027 = 1,024 is to adjust.

3.2. Input of motor nameplate data

To calculate the excitation and torque generating components of the current vector, it is necessary to enter the motor nameplate data correctly.

This is only possible if the controller is inhibited, i.e. RFR ENABLE open, or the STP key pressed.

- **C081 Rated motor power**

This parameter is only required for automation module applications to calculate the absolute reference for the torque. The rated motor power of the Lenze servo motor, which is best adapted to the axis module, is factory-set.

- **C087 Rated motor speed**

- **C088 Rated motor current**

| |
|---|
| For $M_{\text{required}} \ll M_{\text{rated}}$ |
| $C088 = I_{\text{rated}} \cdot \sqrt{\frac{M_{\text{required}}}{M_{\text{rated}}}}$ |

- **C089 Rated motor frequency**

- **C091 cos ϕ motor**

3.3. Setting of operating parameters

The operating parameters must be adjusted according to the specific application requirements. Operating parameters can be modified ON-LINE during operation. However, a preadjustment of the operating parameters before start-up of the motor is recommended.

- **C022 Maximum current I_{\max}**
Factory set to the maximum controller current. An adjustment of the maximum current limitation is only necessary if the maximum current must be smaller than the controller peak current.
- **C011 Maximum speed n_{\max}**
In the case of analog set value provision, the maximum motor speed determines the motor speed at maximum set value. In the case of digital set value provision, n_{\max} limits the motor speed. If $n_{\text{set}} > n_{\max}$ the speed is limited to n_{\max} . (valid for both directions, CW and CCW).
- **C012 Acceleration time T_{ir} , C013 deceleration time T_{if}**
The acceleration and deceleration times refer to a speed change from 0 to n_{\max} . The times T_{ir} and T_{if} to be set can be adjusted as follows:

$$T_{ir} = \frac{t_{ir} \cdot n_{\max}}{n_2 - n_1} \quad T_{if} = \frac{t_{if} \cdot n_{\max}}{n_2 - n_1}$$

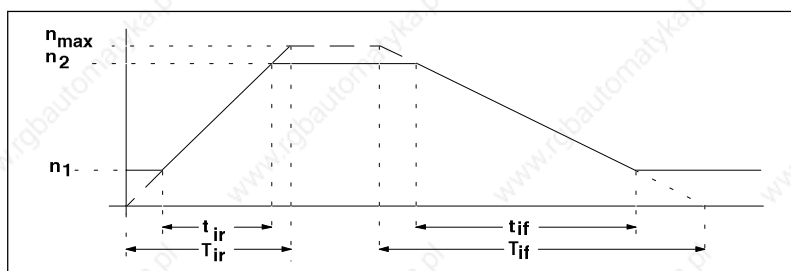

When moving large inertias with short deceleration times, it is possible that the brake energy would not be dissipated by the internal brake resistor. The axis module trips and the fault OUE "overvoltage" or OH1 "overtemperature supply module" is displayed. In this case it is necessary to increase the deceleration time or to connect an external brake resistor.

- **C105 Quick stop deceleration time TQSP**
The quick stop deceleration time is activated by the function QSP quick stop.
- **C039 JOG speed**
An internally stored speed set value can be activated via X5 terminal 24 or via C045. The JOG speed is set under C039.

Speed controller setting

Set a low speed set value. Enable the controller release (close RFR switch or apply a voltage of 13...30 V to X5 terminal 28). The speed controller can now be set. In case of uncontrolled motor running (oscillation etc.), the drive can be immediately stopped by pressing the STP key. After reducing the gain adjustment V_{pn} C070, release the controller again using SH+STP.

- **C070 Gain adjustment V_{pn}**

Increase V_{pn} until the drive becomes unstable (motor noise and LED I_{max} illuminated), then reduce V_{pn} amplification until the drive operates smoothly. Read the V_{pn} value and adjust to one third of the value.

Increase the speed set value. If the motor speed does not follow the higher speed set value, but stays at 50...300 rpm, the drive must be disconnected from the mains and after a period of 5 min, the motor connections U and V must be interchanged.

Switch on the mains and readjust the gain.

- **C071 Integral action time of the speed controller**

Factory setting optimized to the torque loop. It may be necessary to adjust higher values if the field weakening range is completely used or if non-adapted motors are employed. For higher time constants in the speed control loop (e.g. for chain drives), it may also be necessary to readjust the integral action time. To change the integral action time, select the extended code set -2- under code C000. Increase T_n until the drive is stable. Read T_n and adjust to approx. double the value.

- **C072 Amplification of the difference component of the speed controller.**

This adjustment is only necessary if the time has been set to a larger time constant. The difference component of the the speed controller is used for compensation of the time behaviour of the torque control circuit. The adjustment of the difference component is only possible in the extended code set -2-. Change K_d until achieving optimum control behaviour.

4. Additional functions

4.1. Mains failure detection with DC-bus control

Purpose:

In the event of mains failure, this function prevents an uncontrolled coasting of the drives as long as possible for the system. Within this period of time the drives, a speed-controlled, synchronous brake is possible.

Advantages:

- Material cracks can be avoided.
- External UPSs may not be necessary

4.1.1. Requirements

- The axis module 922x and the supply module 921x must be wired according to the charts on page 52.

Pin assignment of the plug X3 at the supply module

| X3 | Function | Condition | Level |
|-----------------------------|---|---|----------------------------|
| 1 GND | Reference potential for analog signals U_G^* and $\overline{NA\&U_G^*}$ | | |
| 2 V_G^* | Monitor signal of the DC-bus voltage V_Z . | $0\text{ V} \leq V_Z \leq 900\text{ V}$ | $0.01 \cdot V_Z$ |
| 3 $\overline{NA\&U_G^*}$ | Combined signal from X3,2 and X3,5. | $X3,5 = \text{HIGH}$ and $V_Z > 440\text{ V} \pm 3\%$ | 10 V |
| | | $X3,5 = \text{LOW}$ or $V_Z \leq 440\text{ V} \pm 3\%$ | $0.01 \cdot V_Z$ |
| 4 $24V_{\text{ext}}$ | External supply for the potential-free output X3,5 | | + 24 V (13 ... 30 V) |
| 5 \overline{NA} | Potential-free output signal for mains failure. | $V_{\text{mains}} > 320\text{ V} \pm 3.5\%$ and $V_Z > 440\text{ V} \pm 3\%$ | HIGH (13 ... 30 V) |
| | | $V_{\text{mains}} \leq 320\text{ V} \pm 3.5\%$ or $V_Z \leq 440\text{ V} \pm 3\%$ | LOW (0 V) |
| 6 GND_{ext} | Reference point for terminal X3,4 and X3,5. | | 0 V of the external supply |

- Configuration C005

| Setting C005 | Input of the combined signals $\overline{NA\&U_G^*}$ at the axis module |
|------------------|---|
| -11-, -21- | Terminals X5,1 and X5,2 |
| -12-, -13-, -30- | Terminals X5,7 and X5,8 |
| -20-, -33- | Mains failure detection with DC-bus control impossible |

Note:

For drive control via LECOM interface, terminals X5,7 and X5,8 are automatically the control terminals evaluating the combined signal, no matter which configuration had been selected under C005.



- Parameter setting of the mains failure detection:
The following codes affect the drive properties in case of mains failure:

| | |
|-------------|--|
| C079 | Proportional gain of the DC-bus voltage controller (V_z -controller) (see signal flow chart p.55) |
| C080 | Integral-action component of the V_z -controller |
| C228 | Acceleration integrator for the set value of the DC-bus voltage |
| C229 | Activation of mains failure detection C229 = -1 : Mains failure detection activated |
| C236 | V_{set1} (V_z -controller). After the detection of a mains failure and the activation of the DC-bus control, the value of C237 is the set value of the V_z -controller |
| C237 | This code indirectly determines the possible speed decrease during a controller cycle. |



- In drive configuration with several controllers and DC-bus connection (one master drive and one or several slave drives), the mains failure detection with DC-bus control may only be activated for the master drive.

4.1.1. Wiring

Note

- For radio interference suppression, all relays have to be equipped with free-wheeling diodes!
- all relays: $R_i < 1K\Omega$



a) Wiring for C005 = 11 und 21

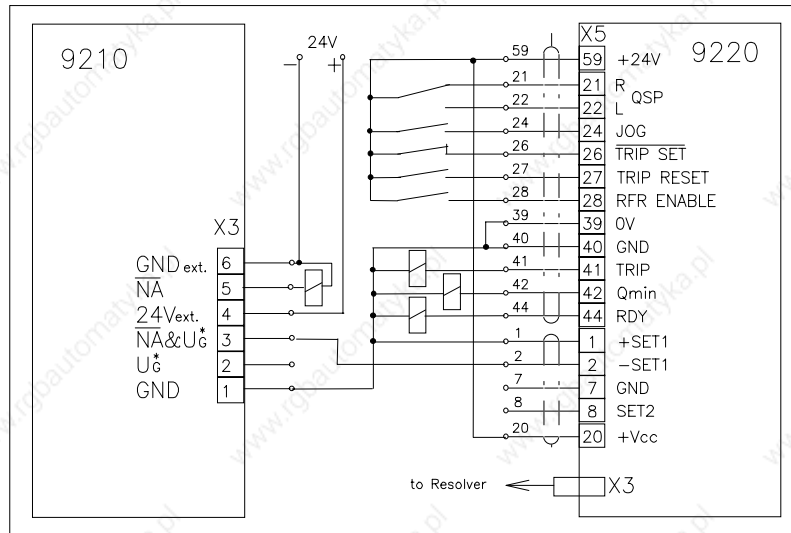

b) Wiring for C005 = 12, 13, 30 and for interface control

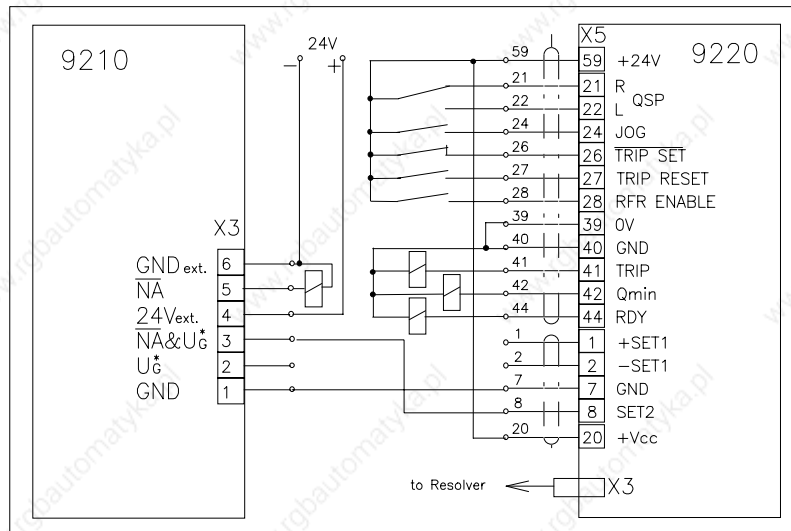

4.1.2. Setting

These setting instructions are meant as guideline and must not always decelerate the machine to standstill before reaching the undervoltage threshold. The parameter setting of the codes, which influences the DC-bus control during mains failure detection (C079, C080, C228, C236, C237), depend on the size of the drive configurations and the mechanical features of the system.

There are minimum speeds at which the energy of the mechanical system is not high enough to compensate the losses which occur during the controlled deceleration (switched-mode power supplies, inverter, machines).

Aim:

- The aim is to have a controlled speed deceleration that allows a DC-bus voltage value which remains higher than the undervoltage threshold for as long as possible. As soon as the value falls below this threshold, pulse inhibit will be set and the drive will coast to standstill.
- The brake chopper should not be activated during the controlled deceleration of the speed. Therefore, the parameter setting of the DC-bus control should be "softly". It is not very important whether the DC-bus can be loaded to the voltage set under C236.

Required measuring units:

- Oscilloscope, at least 2 channels, if possible with memory.

Test set-up:

- Connect channel 1 of the oscilloscope with X5,62 of the axis module (speed monitor).
- Connect channel 2 of the oscilloscope with X3,2 of the supply module (DC-bus monitor).
- If available, connect channel 3 of the oscilloscope with X5,44 of the axis module (RDY-output).

Presettings:

1. Set the speed controller of the axis module drive configuration as usual.
2. Activate the mains failure detection of the master drive (C229 = -1-).
If the function is activated, the RDY-output changes from the HIGH level to the LOW level. As soon as the speed is decelerated to 0, the RDY-output re-changes to HIGH.
3. The relevant codes must be set as follows:

| Code | Presetting |
|------|---|
| C079 | -1- |
| C080 | 150 s |
| C228 | 1/10...1/20 of the natural slow-down time of the machine at maximum operating speed |
| C229 | -1- |
| C236 | 680 V |
| C237 | 1000 rpm or more |

Setting course:

1. Select a medium speed as set value according to the occurring speed range of the system.
2. Switch-off the mains.

The oscillogramme shows the reaching of the undervoltage threshold on channel 2, the DC-bus voltage decreases slowly (see fig. 1)

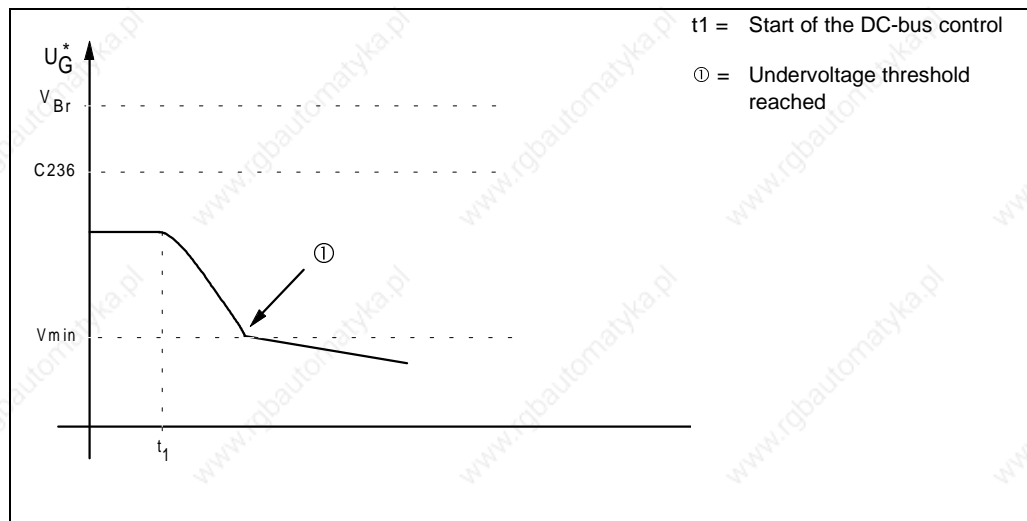

fig. 1: Start of the setting
DC-bus voltage during DC-bus control

3. Increase C079 to reach the undervoltage threshold at a speed as low as possible. For very small final speed values, you may reduce C228.
4. Repeat steps 1.) to 3.) at maximum and minimum system speed.
5. Reduce C080 at maximum system speed until the DC-bus voltage does no longer overshoot the brake-chopper threshold (see fig. 2).
You may also reduce C237 to limit the speed decrease during deceleration.

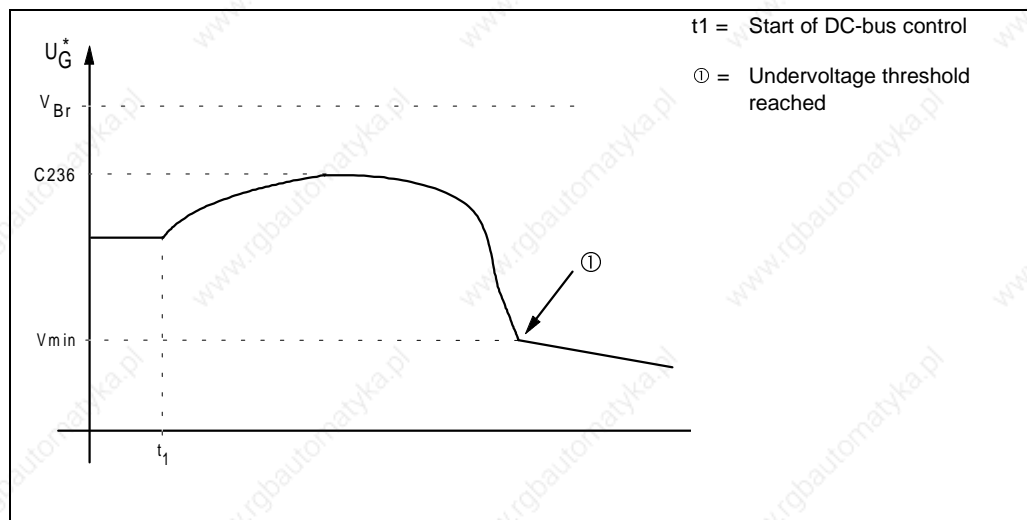

fig. 2: Real setting
DC-bus voltage during DC-bus control

6. The increase of the V_z acceleration integrator C228 prolongs the deceleration period.
7. Save the setting under C003.

4.2. Homing mode

- **C250 Homing mode**

In the homing mode (C250 = -0-) the increments of the master frequency at the DIG.SET input are processed as a relative change of angle. By activating the homing mode (C250 = -1-) it is possible to refer to an absolute angle position of the motor shaft. The homing mode can only be activated if the controller is inhibited. It is initiated by means of JOG function.

Functional sequence:

Start the homing mode by means of the JOG function enable. The RDY signal indicates "not ready". The drive runs at the selected JOG speed. After blocking the JOG signal (e.g. by means of a proximity switch), the drive continues to run to the home position and stops. The RDY signal indicates "ready".

If controller inhibit or QSP are activated during homing, the RDY signal remains "not ready" until the homing process is finished.

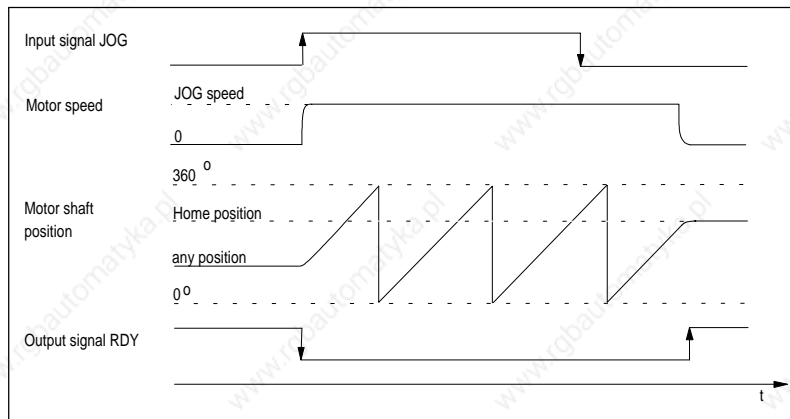

- **C252 Angle offset**

The shift range of the home position is one revolution of the motor shaft. 360° is resolved into 2048 steps. The adjustment can be made ON-LINE when the motor is running. The zero pulse of the encoder emulation X4 is also resolved in 256 steps.

- **C254 Amplification of the angle controller**

The angular controller is active when using a master frequency DIG.SET input or if the homing mode is active. By selecting Vpw=0, the angular controller is deactivated. In this case, the master frequency is processed as speed set value and not as set angle increments. Before adjusting the amplification of the angular controller, the speed controller must be optimized.

- **C159 Homing OK**

C159 displays whether the homing was successful or not:

C159 = -1- homing successfully completed

C159 = -0- homing not completed

C159 may also be used for simulating a homing mode:

Set C159 = -1- and manually activate the angle offset under C252.

4.3. Further additional functions

- **C004 Switch-on display**
Entering a code number under C004 determines which parameter is to be displayed after switching-on.
- **C018 Chopper frequency**
The chopper frequency determines the noise level. The chopper frequency can either be 8 or 16 kHz. Changing the chopper frequency changes the admissible permanent load of the axis module.
- **C255 Following error limit**
If an following error exceeds the value entered under C255 during master frequency operation (C005 = -13- or -21-) and an amplification of the angle controller of C254 > 0, an internal signal will be generated for the error status >>Following error limit exceeded<< . If this signal is applied to the terminal Q_{\min} (X5,42) via C117, the Q_{\min} terminal will change its level from HIGH to LOW as soon as the set limit value is exceeded.

For following errors of more than 3188 increments, also the RDY message will be set to LOW and >>following error<< will be displayed.
(see page 74)

5. Serial interfaces

The 9200 servo axis modules can communicate via the serial interfaces LECOM1 and LECOM2 with superimposed hosts (PLC or PC) as well as Lenze operating units.

The LECOM1 interface (connector X1) is used to process the LECOM A/B protocol. The LECOM1 interface can also be used to connect devices to the RS 232C standard (LECOM-A) or to the RS 485 standard (LECOM-B). The interface is suitable for parameter setting, monitoring, diagnosis and process control.

For more demanding applications, a field bus connecting module can be used. For the parameter setting, this interface is generally called LECOM2.

The following bus systems are available:

- Interbus-S interface module 2110
- Profibus interface module 2130

5.1. LECOM1 interface X1

The standard serial interface X1 fulfills the standard RS 232 C as well as the standard RS 485.

Using the common RS 232 C interface, simple point-to-point connection with a maximum cable length of 15 m can be achieved. Almost every personal computer (PC) or other master system is equipped with this interface. For several drives and larger distances, the RS 485 interface must be used. Only two wires are used to enable the communication of up to 31 controllers via a maximum distance 1200 m.

The LECOM A/B protocol is based on the 1745 ISO standard and supports up to 90 controllers. It recognizes faults and therefore avoids the transmission of faulty data.

Pin assignment X1:

| Pin | Name | Input/Output | Explanation |
|-----|---------|--------------|---------------------------------------|
| 1 | +VCC15 | Output | Supply voltage +15V/50mA |
| 2 | RxD | Input | Data receiving line RS232C |
| 3 | TxD | Output | Data transmitting line RS232C |
| 4 | DTR | Output | Transmission control RS232C |
| 5 | GND | -- | Controller reference potential RS232C |
| 6 | DSR | Input | (unused) |
| 7 | T/R (A) | Output/Input | RS485 |
| 8 | T/R (B) | Output/Input | RS485 |
| 9 | +VCC5 | Output | Supply voltage +5V |

Baud rate: 1200/2400/4800/9600 Bd (to be changed via C125).

Protocol: LECOM-A/B V2.0

5.2. LECOM status messages

- **C068 Operating state**

| Bit no. | Signal |
|------------|---------------------|
| 0, 1, 2, 3 | Operating fault |
| 4, 5, 6, 7 | Communication fault |
| 8 | RFR enable |
| 9 | Qmin |
| 10 | running |
| 11 | IMP |
| 12 | QSP |
| 13 | lmax |
| 14 | Nact = Nset |

- **C069 Controller state**

| Bit no. | Signal |
|---------|--------|
| 0 | BALARM |
| 1 | CALARM |
| 2 | PCHG |
| 3 | REMOT |
| 4 | AUTO |
| 5 | RESET |
| 6 | XXX |
| 7 | RFR |
| 15 | TRIP |

- **C067 Fault numbers of the operating faults (see "Service")**

| --- | OC1 | OC2 | OC5 | OUE | OH1 | OH2 | U15 | CCr | Pr | Sd2 | EEr | UEr |
|-----|-----|-----|-----|-----|-----|-----|-----|-----|----|-----|-----|-----|
| 0 | 11 | 12 | 15 | 22 | 51 | 52 | 70 | 71 | 72 | 82 | 91 | 92 |

Further information on the serial communication LECOM1 (LECOM-A/B) can be obtained from the Operating Instructions LECOM-A/B.

For extensions, the following modules are available:

- 2101 Interface with mains isolation for RS422/RS485
- 2122/2123 Interface for optical fibres (LECOM-LI)

5.3. Table of attributes

If you want to programme the parameter setting or superimposed drive and control functions yourself, the following table will inform you about serial communication via LECOM1 (LECOM A/B) or LECOM2.

Legend

| Code | Meaning |
|-------------------|--|
| Code | Lenze code number |
| DS | Data structure E = Single variable (only one parameter element) A = Array variable (several parameter elements can be selected by the code for the preselection or by LECOM sub code.) I = Image variable (several parameter elements can only be selected by the code for preselection). |
| P/S | Parameter setting/control (corresponding to C001) P = Parameter setting S = Control |
| DT | Data type B8 = 1 byte bit coded B16 = 2 byte bit coded VS = ASCII string FIX32 = 32-bit-value with sign; decimal with four decimal places Examples: 1.2 = 12000FIX32-dez 00002EEOFIX32-hex -10.45 = -104500FIX32-dez FFE67CCFIX32-hex N16 = 16-bit value with sign; 0 = 0; 100% = 2 ¹⁴ 100% = 16384N16-dez 4000N16-hex -50% = -8192N16-dez E000N16-hex |
| DL | Data length in byte |
| LCM-R/W | Access authorization for LECOM Ra = Reading always permitted W = Writing permitted under certain conditions (e.g. operating mode, controller inhibit) Wa = Writing is always permitted |
| LCM1-Form. | LECOM A/B-format (see technical description LECOM A/B) |
| AIF-PZD | Process data in the automation interface. Mapping on LECOM2 process data channel is possible. PD = Process data |
| LCM2-Index | Number (index) under which the parameter is addressed when using LECOM 2. |

| Code | P/S | DS | DT | DE | D/L | LCM-R/W | LCM Form. | AIF-PZD | LCM2 Index |
|------|-----|----|-------|----|-----|---------|-----------|---------|------------|
| C000 | P | E | FIX32 | 1 | 4 | Ra | VD | -- | 24575 |
| C001 | P | E | FIX32 | 1 | 4 | Ra/Wa | VD | -- | 24574 |
| C002 | P | E | FIX32 | 1 | 4 | Ra/W | VD | -- | 24573 |
| C003 | P | E | FIX32 | 1 | 4 | Ra/W | VD | -- | 24572 |
| C004 | P | E | FIX32 | 1 | 4 | -- | VD | -- | 24571 |
| C005 | P | E | FIX32 | 1 | 4 | Ra/W | VD | -- | 24570 |
| C009 | P | E | FIX32 | 1 | 4 | -- | VD | -- | 24566 |
| C011 | P | E | FIX32 | 1 | 4 | Ra/W | VD | -- | 24564 |
| C012 | P | E | FIX32 | 1 | 4 | Ra/W | VD | -- | 24563 |
| C013 | P | E | FIX32 | 1 | 4 | Ra/W | VD | -- | 24562 |
| C017 | P | E | FIX32 | 1 | 4 | Ra/W | VD | -- | 24558 |
| C018 | P | E | FIX32 | 1 | 4 | Ra/W | VD | -- | 24557 |
| C022 | P | E | FIX32 | 1 | 4 | Ra/W | VD | -- | 24553 |
| C025 | P | E | FIX32 | 1 | 4 | Ra/W | VD | -- | 24550 |
| C026 | P | I | FIX32 | 1 | 4 | Ra/W | VD | -- | 24549 |
| C027 | P | I | FIX32 | 1 | 4 | Ra/W | VD | -- | 24548 |
| C028 | P | I | FIX32 | 1 | 4 | Ra/W | VD | -- | 24547 |
| C030 | P | E | FIX32 | 1 | 4 | Ra/W | VD | -- | 24545 |
| C031 | P | E | FIX32 | 1 | 4 | Ra/W | VD | -- | 24544 |
| C032 | P | E | FIX32 | 1 | 4 | Ra/W | VD | -- | 24543 |
| C033 | P | E | FIX32 | 1 | 4 | Ra/W | VD | -- | 24542 |
| C039 | P | E | FIX32 | 1 | 4 | Ra/W | VD | -- | 24536 |
| C040 | P | E | FIX32 | 1 | 4 | Ra/W | VD | -- | 24535 |
| C041 | S | E | FIX32 | 1 | 4 | Ra/W | VD | -- | 24534 |
| C042 | S | E | FIX32 | 1 | 4 | Ra/W | VD | -- | 24533 |
| C043 | P | E | FIX32 | 1 | 4 | Ra/W | VD | -- | 24532 |
| C045 | S | E | FIX32 | 1 | 4 | Ra/W | VD | -- | 24530 |
| C046 | S | E | FIX32 | 1 | 4 | Ra/W | VD | -- | 24529 |
| C047 | S | E | FIX32 | 1 | 4 | Ra/W | VD | -- | 24528 |
| C050 | S | E | FIX32 | 1 | 4 | Ra | VD | -- | 24525 |
| C051 | S | E | FIX32 | 1 | 4 | Ra | VD | -- | 24524 |
| C054 | S | E | FIX32 | 1 | 4 | Ra | VD | -- | 24521 |
| C056 | S | E | FIX32 | 1 | 4 | Ra | VD | -- | 24519 |
| C059 | P | E | FIX32 | 1 | 4 | Ra | VD | -- | 24516 |
| C060 | S | E | FIX32 | 1 | 4 | Ra | VD | -- | 24515 |
| C061 | S | E | FIX32 | 1 | 4 | Ra | VD | -- | 24514 |
| C067 | P | E | FIX32 | 1 | 4 | Ra | VD | -- | 24508 |
| C068 | S | E | B16 | 1 | 2 | Ra | VH | -- | 24507 |
| C069 | S | E | B8 | 1 | 1 | Ra | VH | -- | 24506 |
| C070 | P | E | FIX32 | 1 | 4 | Ra/W | VD | -- | 24505 |
| C071 | P | E | FIX32 | 1 | 4 | Ra/W | VD | -- | 24504 |
| C072 | P | E | FIX32 | 1 | 4 | Ra/W | VD | -- | 24503 |
| C079 | P | E | FIX32 | 1 | 4 | Ra/W | VD | -- | 24496 |
| C080 | P | E | FIX32 | 1 | 4 | Ra/W | VD | -- | 24495 |
| C081 | P | E | FIX32 | 1 | 4 | Ra/W | VD | -- | 24494 |
| C087 | P | E | FIX32 | 1 | 4 | Ra/W | VD | -- | 24488 |
| C088 | P | E | FIX32 | 1 | 4 | Ra/W | VD | -- | 24487 |
| C089 | P | E | FIX32 | 1 | 4 | Ra/W | VD | -- | 24486 |
| C091 | P | E | FIX32 | 1 | 4 | Ra/W | VD | -- | 24484 |
| C093 | S | E | FIX32 | 1 | 4 | Ra | VD | -- | 24482 |
| C094 | P | E | FIX32 | 1 | 4 | Ra/W | VD | -- | 24481 |
| C098 | P | E | FIX32 | 1 | 4 | Ra/W | VD | -- | 24477 |
| C099 | P | E | VS | 1 | 6 | Ra | VS | -- | 24476 |
| C105 | P | E | FIX32 | 1 | 4 | Ra/W | VD | -- | 24470 |
| C117 | P | E | FIX32 | 1 | 4 | Ra/W | VD | -- | 24458 |
| C125 | P | E | FIX32 | 1 | 4 | Ra/W | VD | -- | 24450 |

| Code | P/S | DS | DT | DE | D/L | LCM-R/W | LCM Form. | AIF-PZD | LCM2 Index |
|------|-----|----|-------|----|-----|---------|-----------|---------|------------|
| C140 | P | E | FIX32 | 1 | 4 | Ra/W | VD | -- | 24435 |
| C153 | P | E | FIX32 | 1 | 4 | Ra/W | VD | -- | 24422 |
| C154 | P | E | FIX32 | 1 | 4 | Ra/W | VD | -- | 24421 |
| C158 | S | E | FIX32 | 1 | 4 | Ra | VD | -- | 24417 |
| C159 | P | E | FIX32 | 1 | 4 | Ra/W | VD | -- | 24416 |
| C161 | P | E | FIX32 | 1 | 4 | Ra | VD | -- | 24414 |
| C162 | P | E | FIX32 | 1 | 4 | Ra | VD | -- | 24413 |
| C163 | P | E | FIX32 | 1 | 4 | Ra | VD | -- | 24412 |
| C164 | P | E | FIX32 | 1 | 4 | Ra | VD | -- | 24411 |
| C165 | P | E | FIX32 | 1 | 4 | Ra | VD | -- | 24410 |
| C166 | P | E | FIX32 | 1 | 4 | Ra | VD | -- | 24409 |
| C167 | P | E | FIX32 | 1 | 4 | Ra | VD | -- | 24408 |
| C168 | P | E | FIX32 | 1 | 4 | Ra | VD | -- | 24407 |
| C180 | P | E | FIX32 | 1 | 4 | Ra/W | VD | -- | 24395 |
| C183 | P | E | FIX32 | 1 | 4 | Ra/W | VD | -- | 24392 |
| C184 | P | E | FIX32 | 1 | 4 | Ra/W | VD | -- | 24391 |
| C185 | P | E | FIX32 | 1 | 4 | Ra/W | VD | -- | 24390 |
| C186 | P | E | FIX32 | 1 | 4 | Ra/W | VD | -- | 24389 |
| C187 | P | E | FIX32 | 1 | 4 | Ra/W | VD | -- | 24388 |
| C200 | P | E | VS | 1 | 14 | Ra | VS | -- | 24375 |
| C205 | P | E | OS | 1 | 0 | Ra | VO | -- | 24370 |
| C228 | P | E | FIX32 | 1 | 4 | Ra/W | VD | -- | 24347 |
| C229 | P | E | FIX32 | 1 | 4 | Ra/W | VD | -- | 24346 |
| C236 | P | E | FIX32 | 1 | 4 | Ra/W | VD | -- | 24339 |
| C237 | P | E | FIX32 | 1 | 4 | Ra/W | VD | -- | 24338 |
| C249 | P | E | FIX32 | 1 | 4 | Ra/W | VD | -- | 24326 |
| C250 | P | E | FIX32 | 1 | 4 | Ra/W | VD | -- | 24325 |
| C252 | P | E | FIX32 | 1 | 4 | Ra/W | VD | -- | 24323 |
| C253 | P | E | FIX32 | 1 | 4 | Ra/W | VD | -- | 24322 |
| C254 | P | E | FIX32 | 1 | 4 | Ra/W | VD | -- | 24321 |
| C255 | P | E | FIX32 | 1 | 4 | Ra/W | VD | -- | 24320 |
| C300 | S | E | FIX32 | 1 | 4 | Ra | VD | -- | 24275 |
| C350 | P | E | FIX32 | 1 | 4 | Ra | VD | -- | 24225 |
| C351 | P | E | FIX32 | 1 | 4 | Ra | VD | -- | 24224 |
| C352 | P | E | FIX32 | 1 | 4 | Ra/W | VD | -- | 24223 |
| C353 | P | A | FIX32 | 8 | 4 | Ra | VD | -- | 24222 |
| C354 | P | A | FIX32 | 8 | 4 | Ra | VD | -- | 24221 |
| C355 | P | A | FIX32 | 8 | 4 | Ra | VD | -- | 24220 |
| C356 | P | A | FIX32 | 8 | 4 | Ra | VD | -- | 24219 |
| C357 | P | E | FIX32 | 1 | 4 | Ra/W | VD | -- | 24218 |
| C358 | P | A | FIX32 | 3 | 4 | Ra | VD | -- | 24217 |
| C359 | P | E | FIX32 | 1 | 4 | Ra | VD | -- | 24216 |
| C370 | P | E | FIX32 | 1 | 4 | Ra/W | VD | -- | 24205 |
| C380 | S | E | I16 | 1 | 2 | Ra/W | VH | PZD | 24195 |
| C381 | S | E | I16 | 1 | 2 | Ra | VH | PZD | 24194 |
| C382 | S | E | I16 | 1 | 2 | Ra | VH | PZD | 24193 |
| C387 | S | E | I16 | 1 | 2 | Ra | VH | PZD | 24188 |
| C388 | S | E | I16 | 1 | 2 | Ra/W | VH | PZD | 24187 |
| C391 | S | E | U16 | 1 | 2 | Ra | VH | PZD | 24184 |
| C400 | P | E | FIX32 | 1 | 4 | -- | VD | -- | 24175 |
| C401 | P | E | FIX32 | 1 | 4 | -- | VD | -- | 24174 |
| C402 | P | E | FIX32 | 1 | 4 | -- | VD | -- | 24173 |
| C403 | P | E | FIX32 | 1 | 4 | -- | VD | -- | 24172 |
| C404 | P | E | FIX32 | 1 | 4 | -- | VD | -- | 24171 |
| C405 | P | E | FIX32 | 1 | 4 | -- | VD | -- | 24170 |

6. Code table

The following table shows which settings can be performed with which codes. Detailed explanation about the codes and the functions which can be achieved, are described in special chapters. For the acceptance of parameters see page 41.

How to read the code table:

| Column | Short form | Meaning |
|------------|---------------|--|
| Code | C000 | Code digit of the standard code set |
| | C017* | Code digit of the extended code set |
| | C043 (L) | Code digit can only be reached via the LECOM interface; code is not displayed |
| Parameter | -0- | The factory setting is printed in bold. |
| Acceptance | ON-LINE | Unit immediately accepts new parameter |
| | SH + PRG ⇒ | Unit accepts new parameter after pressing SH+PRG Unit accepts parameter only if the controller is inhibited when pressing SH+PRG. |

| Code | Name | Parameter | Acceptance | see page | |
|-------------|---------------------|------------|--|--------------------|----|
| C000 | Code set | -0- | Standard code set read only | SH+PRG password | 45 |
| | | -1- | Standard code set | | |
| | | -2- | Extended code set | | |
| | | -9- | Service code set (service password necessary) | | |
| | | -11- | Code set for automation module | | |
| | | -P- xxx | Password request Enter password | | |
| C001 | Operating mode | -0- | Control: Parameter setting: | ⇒ | 45 |
| | | -1- | Terminals Keypad | | |
| | | -1- | Keypad Keypad | | |
| | | -2- | Terminals LECOM1 | | |
| | | -3- | LECOM1 LECOM1 | | |
| | | -4- | Terminals LECOM2 | | |
| | | -5- | LECOM2 LECOM2 | | |
| | | -6- | LECOM2 Keypad | | |
| -7- | LECOM2 LECOM1 | | | | |
| C002 | Load parameter set | -0- | Factory setting | ⇒ | |
| C003 | Store parameter set | -1- | Parameter set 1 | SH+PRG | |
| C004 | Switch-on display | 51 | Code no. for parameter displayed after first switch-on | SH+PRG | 57 |

| Code | Name | Parameter | Acceptance | see page | |
|--------------|---------------------------------------|---|---|----------|----|
| C005* | Configuration | -11- Speed control n_{set}: analog, X5, terminals 7, 8 -12- Speed control n _{set} : analog, X5, terminals 1, 2 -13- Speed control n _{set} : Dig. Set X2 -20- Speed control with corresponding variable torque limitation n _{set} : analog X5, terminals 1, 2 M _{set} : analog X5, terminals 7, 8 -21- Speed control with corresponding variable torque limitation n _{set} : Dig. Set X2 M _{set} : analog, X5, terminals 7, 8 -30- Torque control M _{set} : analog X5, terminals 1,2 -33- Torque control with corresponding variable speed limitation n _{set} : analog X5, terminals 7, 8 M _{set} : analog X5, terminals 1,2 | ⇒ | 46 | |
| C009* | Controller address | 1 | Bus participant number LECOM-A/B Setting range: 1 - 99 10, 20, 99 reserved for broadcast | SH+PRG | |
| C011 | n _{max} (maximum speed) | 3000 | Setting range: 100...8000 rpm Step: 1 rpm | ON-LINE | |
| C012 | T _{ir} (acceleration time) | 0.01 | Setting range: 0.00...990 s Step: 0.01s from 0.00...1s 0.1s from 1...10s 1s from 10...100s 10s from 100...990s | ON-LINE | 48 |
| C013 | T _{if} (deceleration time) | 0.01 | Setting range: 0.00...990 s Step: 0.01s from 0.00...1s 0.1s from 1...10s 1s from 10...100s 10s from 100...990s | ON-LINE | 48 |
| C017* | Q _{min} -treshold | 10 | Setting range: 0...8000 rpm Step: 1 rpm When the motor speed is lower than the Q _{min} -treshold, output Q _{min} is set to 0 V. | ON-LINE | |
| C018* | f _{chop} (Chopper frequency) | -0- -1- | f_{chop} = 8 kHz f _{chop} = 16 kHz | ⇒ | 57 |
| C022 | I _{max} (maximum current) | xxx | Step: 0.1 A | ON-LINE | 48 |

| Code | Name | Parameter | Acceptance | see page |
|-------|-------------------------|--|------------|----------|
| C025* | Encoder | -0- -1- -3- Dig. Set master frequency X2 -5- -13- noe encoder selected for setting bipolar set value X5, terminals 1, 2 unipolar set value X5, terminals 7, 8 act. resolver value X3 | SH+PRG | 46 |
| C026* | Encoder constant | -0- -1- -2- -3- -4- no encoder constant 512 increments/revolution 1024 increments/revolution 2048 increments/revolution 4096 increments/revolution | SH+PRG | 46 |
| C027* | Encoder setting | -0- 1.000 no setting required Setting range: -5...0...+5 LECOM: -5000...0...+5000 Step: 0.001 Adjustable speed ratio between slave and master drive n_{set}/n_{master} when using the Dig. Set input. | ON-LINE | 46 |
| C028* | Encoder setting 2 | -0- 1.000 no setting required Setting range: -5...0...+5 LECOM: -5000...0...+5000 Step: 0.001 Second adjustable speed ratio for the Dig. Set input. The controller is enabled (changing the parameter form C027 to C028) via code C 140. | ON-LINE | 46 |
| C030* | Encoder simulation | -1- -2- -3- -4- 2048 increments/revolution 256 increments/revolution 512 increments/revolution 1024 increments/revolution | SH+PRG | |
| C031* | n _{offset} | 0 Setting range: -1000...+1000 Step: 10 mV Offset adjustment of the selected analog speed set value input | ON-LINE | |
| C032* | Ratio numerator | 0.1 Setting range: -3.2767...+3.2767 Step: 0.0001 Numerator of the gearbox factor for the Dig. Set input. The total ratio can be obtained from the follow. formula: $V = \frac{C027 \cdot C032}{C033} \text{ or } V = \frac{C028 \cdot C032}{C033}$ Due to an internal limitation, only values from $V = -5.000...+5.000$ can be realized. | ON-LINE | 46 |
| C033* | Ratio denominator | 0.1 Setting range: +0.0001...+3.2767 Step: 0.0001 Denominator of the gearbox factor for the Dig.Set input (formula: see C032) | ON-LINE | 46 |
| C039 | JOG speed | 20 Setting range: - n_{max} ...+ n_{max} Step: 1 rpm | ON-LINE | |
| C040 | RFR (controller enable) | -0- -1- Controller inhibited Controller enabled | SH+PRG | |

| Code | Name | Parameter | | Acceptance | see page |
|-----------------|---|------------|--|------------|----------|
| C041 | CW/CCW | -0- -1- | Set value not inverted Set value inverted | SH+PRG | |
| C042 | QSP (Quick stop) | -0- -1- | Quick stop inactive Quick stop active (The speed set value goes to digital 0 with the quick stop deceleration time under C105) | SH+PRG | |
| C043 (L) | Trip Reset | -0- -1- | no act. fault/ reset fault actual fault | ON-LINE | |
| C045 | JOG enable | -0- -1- | JOG set value inhibited JOG set value enabled | SH+PRG | |
| C046 | n _{set 1} (speed set value 1) | xxxx | Setting range: -n _{max} ...+n _{max} Step: 1 rpm Display of the externally adjusted speed set value. For keypad and LECOM control: on-line set value selection | ON-LINE | |
| C047 | M _{max} (torque limit) | xxx | Setting range: 0...100.0% or -100.0...+100.0% for torque control Step: 0.1% The maximum torque which can be obtained, depends on the type of servo motor and the axis module employed | ON-LINE | |
| C050 | n _{set 2} (speed set value 2) | _xxxx | Setting range: -n _{max} ...+n _{max} Step: 1 rpm Effective speed set value at speed controller input | read only | |
| C051 | n _{act} (motor shaft speed) | _xxxx | Setting range: -9765...9765 rpm Step: 1 rpm | read only | |
| C054 | I _{mot} (motor current) | xxx | Setting range: 0.0...maximum current Step: 0.1 A The displayed value is calculated from the sinus oscillations of the current. the difference to the actual effective motor current is approx. 10%. In the field weakening range, a larger difference may be possible. | read only | |
| C056 | M _{set} (effective torque set value) | xxx | Setting range: -100.0...+100.0% Step: 0.1% The maximum torque which can be obtained (100%) depends on the type of servo motor and the axis module employed | read only | |
| C059* | Pole pair number | xx | | read only | |
| C060* | Rotor position | xxxx | Setting range: 0...2047 increments Step: 1 increment | read only | |

| Code | Name | Parameter | | Acceptance | see page |
|-----------------|---|-------------------|--|------------|----------|
| C061 | Utilization I x t | xxxx | Setting range: 0.0...+100.0% Step: 0.1% The indicated value is determined by the current-time integral I x t of the controller current. When reaching 100% the I x t monitoring sets overload trip | read only | |
| C067 | Fault diagnosis | xxx | see under "Service" | | 74 |
| C068 (L) | Operating state | | see under "Service" | read only | 59 |
| C069 (L) | Controller state | | see under "Service" | read only | 59 |
| C070 | V _{pn} (gain of speed controller) | 30 | Setting range: 0...500 Step: 1 | ON-LINE | 49 |
| C071* | T _n (Integral action time of speed controller) | 10 9999 | Setting range: 2.5...100 ms Step: 0.5 ms Deactivate integral component | ON-LINE | 49 |
| C072* | k _d (differential amplification of speed controller) | 0 | Setting range: 0...5 Step: 0.1 | ON-LINE | 49 |
| C079* | V _p (V _z -controller) | 1000 | Setting range: 0...9000 Step: 1 | ON-LINE | 53 |
| C080* | T _n (V _z -controller) | 1.0 s | Setting range: 0.01...150 | ON-LINE | 53 |
| C081* | Rated motor power | xxx.x | Setting range: 0.1...650 kW Step: 0.1 kW | ⇒ | 47 |
| C087 | Rated motor speed | xxxx | Setting range: 300...6000 rpm Step: 1 rpm | ⇒ | |
| C088 | Rated motor current | xxx | Setting range: 0.1A...max. controller current Step: 0.01 A | ⇒ | |
| C089 | Rated motor frequency | xxx.x | Setting range: 10.0...300.0 Hz Step: 0.1 Hz | ⇒ | |
| C091 | cos φ Motor | x.xx | Setting range: 0.50...0.99 Step: 0.01 | ⇒ | |
| C093* | Controller identification | xx | | read only | |
| C094* | Pass word | 0 | enter any password (0...999) no password defined | SH+PRG | 42 |
| C098 | Language | -0- -1- -2- | German English French Note: The setting will not be overwritten when loading the factory setting! | ⇒ | |
| C099* | Software version | 92_5.x | Number to identify the software version | read only | |
| C105 | Quick stop deceleration time T _{QSP} | 0.01 | Setting range: 0.00...990 s Step: 0.01 s from 0.00...1 s 0.1 s from 1...10 s 1 s from 10...100 s 10 s from 100...990 s | ON-LINE | 48 |



| Code | Name | Parameter | Acceptance | see page |
|-------|-----------------------------|--|------------|----------|
| C117* | Assignment of Qmin terminal | -0- Terminal X5,42 has the function: Qmin -1- Terminals X5,42 has the function: following error limit reached If code C117 is set to -1-, the terminal X5,42 changes from HIGH to LOW level as soon as reaching the following error limit C255. -2- Terminal X5,42 has the function: controller enable. If code C117 is set to -2- the High level of terminal X5,42 displays an pulse enable of the rectifier. Note: If the function pulse enable is assigned to terminal X5,42 to control a mechanical brake please note that you set Code117 to -2- before controlling the brake. The loading of the factory setting deactivates this function. | → | |
| C125* | Baud rate | -0- 9600 baud -1- 4800 baud -2- 2400 baud -3- 1200 baud | SH+PRG | |
| C140* | Enable encoder setting | -0- C027 active -1- C028 active | SH+PRG | 46 |
| C153* | Minimum limit monitor 1 | 0 Setting range: 0 rpm...C154 Step: 1 rpm Setting of the minimum limit to give the speed to monitor output 1. Speeds, the absolute number of which is smaller than the minimum limit, generate 0 V on the monitor output 1 of terminal 62. | ON-LINE | |
| C154* | Maximum limit monitor 1 | 3000 Setting range: C153...9000 rpm Step: 1 rpm Corresponds to an output voltage of 10 V at terminal 62. Speeds > C154 generate a 10 V level on the monitor output. | ON-LINE | |
| C158* | Actual following error | xxxx Display range: -3188...3188 increments Step: 1 increment | read only | |
| C159* | Homing OK | -0- Homing not finished -1- Homing successfully finished The status -1- can also be set. Therefore it is possible after mains connection to start without homing, in the homing mode (C250 = 1) with Dig.-Set operation. The angular offset C252 is then set to 0. | SH+PRG | |

| | | | | | |
|---|----------------------|--|--|-----------|--|
| C161 ... C168 (L) | Saved fault messages | | Display of the last eight fault messages saved under C068, readable only via LECOM. The last fault reset is in C161. | read only | |
| C200 (L) | Software version | | Display of the software version, readable only via LECOM | read only | |

| Code | Name | Parameter | Acceptance | see page | |
|----------|--|--|---|----------|----|
| C228* | Acceleration time (V _Z -controller) | 0.01 | Setting range: 0.00...990 s Step: 0.01 s from 0.00...1 s 0.1 s from 1...10 s 1 s from 10...100 s 10 s from 100...990 | ON-LINE | 53 |
| C229* | Activation V _Z -controller | -0- -1- | Mains failure detection with V _Z -control not activated Mains failure detection with V _Z -control activated | ⇒ | 53 |
| C236* | V _{set} (V _Z -controller) | 600 | Setting range: 300...900 V Step: 1 V | ON-LINE | 53 |
| C237* | Influence of V _Z -control | 1000 | Setting range: 1...8000 rpm Step: 1 rpm | ON-LINE | 53 |
| C249 (L) | LECOM1-code bank | -0- -1- -2- -3- -4- -5- -6- -7- | C000 to C255 C250 to C505 C500 to C755 C750 to C1005 C1000 to C1255 C1250 to C1505 C1500 to C1755 C1750 to C2000 | SH+PRG | |
| C250* | Homing mode | -0- -1- | not active active | ⇒ | 56 |
| C252* | Angle offset | 0 | Setting range: 0...2047 Step: 1 | ON-LINE | 56 |
| C253* | Speed-proportional angle offset | 8.5 | Setting range: -819.1...+819.1 increments (at 4000 rpm) Step: 1 Possibility to correct an angular offset, which is proportional to the speed and depending on the cycle time. The setting refers to an incremental deviation of 4000 rpm. | ON-LINE | |
| C254* | V _{pw} | 14 | Setting range: 0...16 Step: 1 | ON-LINE | 56 |
| C255* | Following error limit | 10 | Setting range: 10...3071 increments Step: 1 increment | ON-LINE | 57 |



| Code | Name | Parameter | Acceptance | see page |
|-----------------|---------------------------------------|--|------------|----------|
| C370* | Automation interface | -0- Automation interface active Automation interface inactive -1- The automation communication must be activated when using an automation module or a field bus connection LECOM2. If the communication is enabled, without communicating to the other side, the controller remains inhibited. The communication via the automation interface can be activated independently of the operating mode C001 when the controller is inhibited (C040 = 0). Caution! To ensure a faultless initialization, the LECOM interface may only be accessed after one sec. Note: The setting will not be overwritten when loading factory setting! | | |
| C380 (L) | RP-set speed (corresponds to C046) | _xxxxx Display range: -26844...+26844 (8000 rpm = 26844) Step: 1 | ON-LINE | |
| C381 (L) | RP-nset2 (corresponds to C050) | _xxxxx Display range: -26844...+26844 (8000 rpm = 26844) Step: 1 | read only | |
| C382 (L) | RP-actual speed (corresponds to C051) | _xxxxx Display range: -32767...+32767 (9765 rpm = 32767) Step: 1 Note: Quick display without time message! | read only | |
| C387 (L) | RP-set torque (corresponds to C056) | _xxxxx Display range: -32767...+32767 (100% = 32767) Step: 1 | read only | |
| C388 (L) | RP-Mlimit (corresponds to C047) | _xxxxx Display range: -32767...+32767 Step: 1 | ON-LINE | |
| C391 (L) | RP-act. angle (corresponds to C060) | xxxxx Display range: 0...65535 (360° = 16384) Step: 1 | read only | |

7. Signal flow chart axis modules

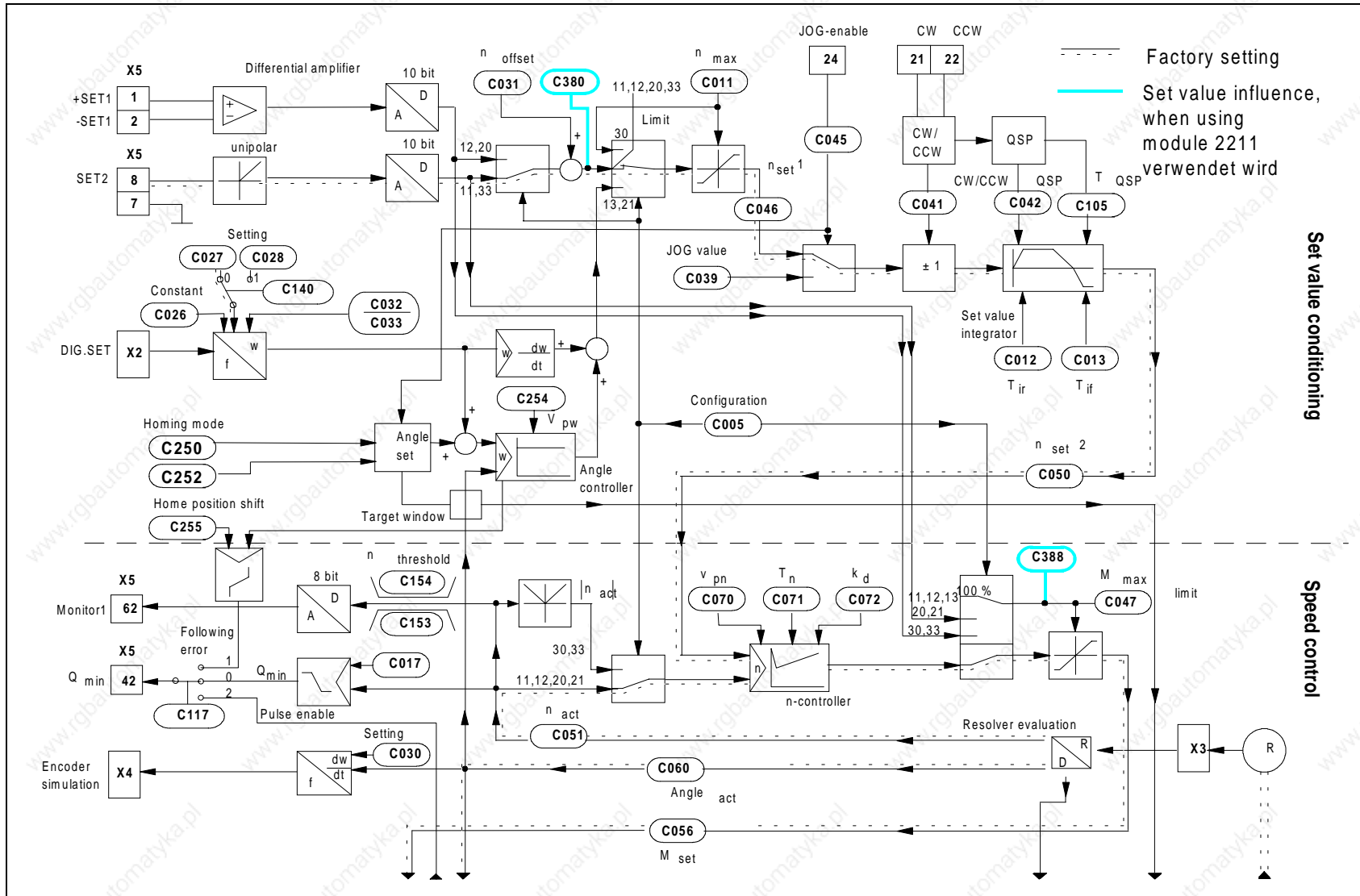

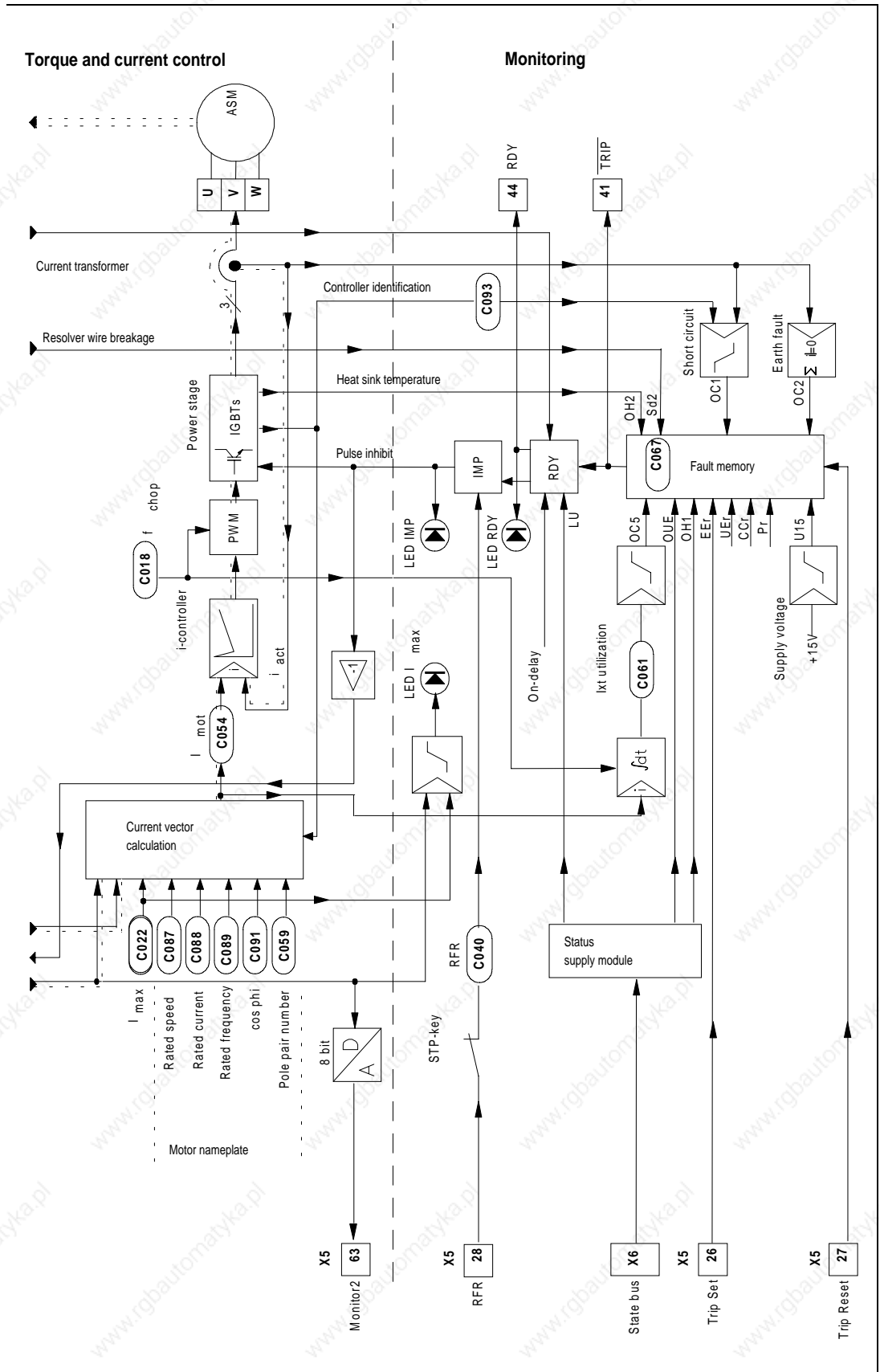

Parameter setting

Service

1. Monitoring messages

The servo drives of the 9200 series have numerous monitoring functions, to protect against non-permissible operating conditions. When such a protective function is activated, it either causes a corresponding message on the controller display and pulse inhibit (IMP) or, in addition (TRIP) setting. The type of fault is immediately displayed. After having removed the fault, the pulse inhibit is released automatically. Faults, however, causing a TRIP setting must be reset und C067 by pressing SH+PRG or by a high signal on input X5, terminal 27, TRIP reset.

1.1. Monitoring without activating pulse inhibit

- **Following error**

The increments of the master frequency set value (Dig.Set) are interpreted as angle increments (condition: $V_{pw} > 0$). If the drive cannot follow the set increments the message "Following error" will be displayed as soon as a following error exceeds 3188 increments (2048 increments $\hat{=}$ 360° at the motor shaft). The error message disappears when the motor reaches the set angle. A following error > 3188 increments cannot be corrected.

1.2. Monitoring with activating pulse inhibit

- **LU Undervoltage**

The mains voltage of the supply module is monitored by measuring the DC bus voltage. If the DC bus voltage decreases below $330V \pm 4\%$, the servo controllers cannot continue to operate. The axis modules are inhibited via the State Bus. If the mains voltage increases above $430V \pm 3\%$ again, the axis modules are released again.

1.3. Monitoring with TRIP setting

- **OC1 Short circuit**

OC1 is displayed if the current controller of the axis modules is not able to limit the output current of the controller to the peak current. Check if there is a short circuit in the motor or the motor supply cable.

- **OC2 Earth fault**

An earth fault current is detected if the total of the phase output current is not 0. Check if there is an earth fault in the motor or the motor supply cable.

Caution:

Before switching on the mains again, it must be ensured that the earth fault has been removed. The inverter free wheeling diodes may be destroyed by earth faults.



- **OC5 Overload axis module (I · t)**

The servo controllers can be overloaded up to their peak current for a certain period of time. The possible duration of overload without Trip setting depends on its intensity. When exceeding the time limit, the fault OC5 "overload" is displayed. The current/time ratios that do not lead to Trip setting are shown in the overload diagrams below. These overload diagrams show permissible overcurrents, necessary recovery times and load cycles. Take into consideration that the rated currents of the axis modules depend on the chopper frequency set under C018 (see Technical data, page 6).

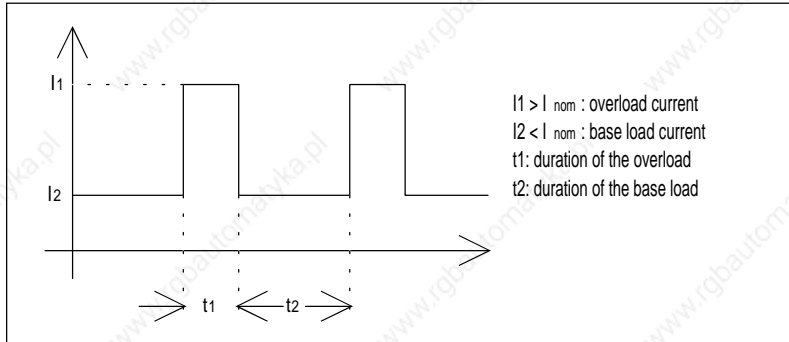

Overload chart for $f_{chop} = 8 \text{ kHz}$

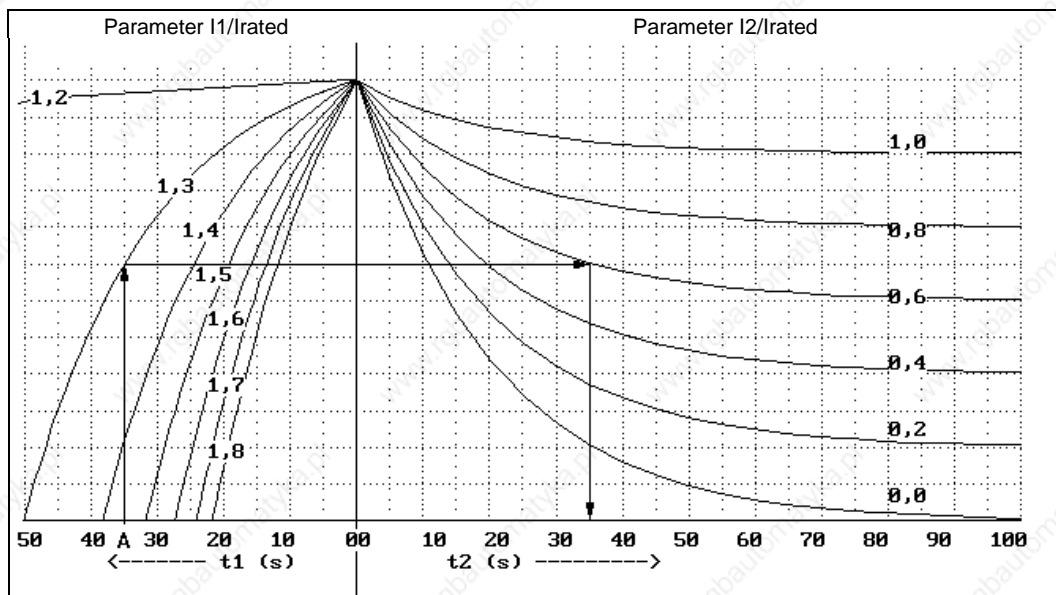

Example A

given: $f_{chop} = 8 \text{ kHz}$
 overload $I_1 = 1,3 \cdot I_{rated}, t_1 = 35 \text{ s}$
 base load $I_2 = 0,6 \cdot I_{rated}$

required: minimum duration of the base load t_2

result: $t_2 = 35 \text{ s}$

Overload chart for $f_{chop} = 16\text{kHz}$

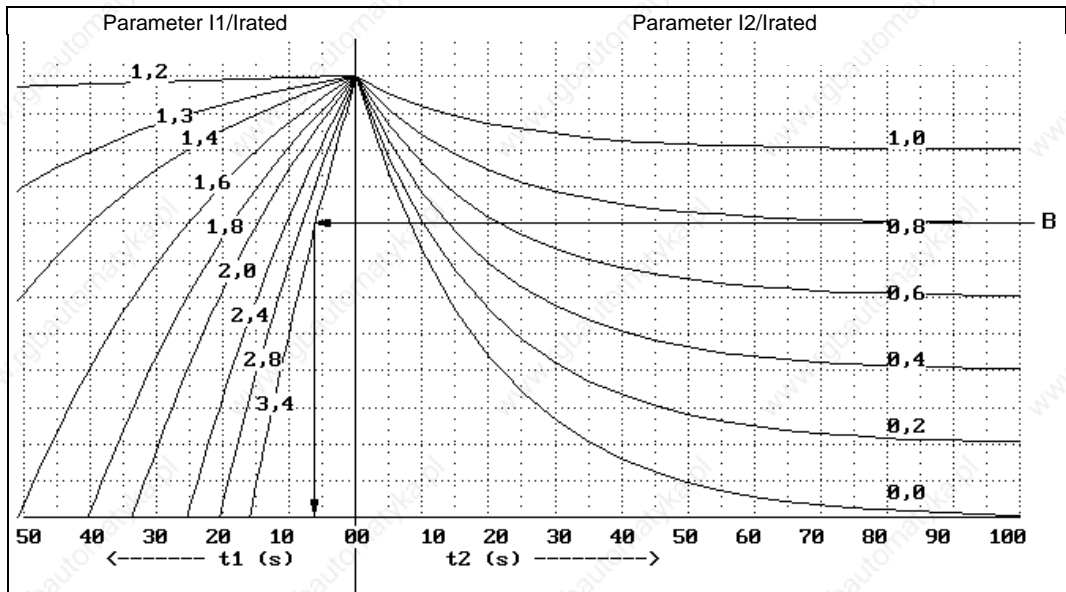

Example B

given: $f_{chop} = 16\text{kHz}$
 overload $I_2 = 0,8 \cdot I_{rated}$
 overload $I_1 = 3,4 \cdot I_{rated}$

required: maximum duration of the overload t_1

result: $t_1 = 7\text{s}$

OUE Overvoltage

If the DC bus voltage exceeds 750 V due to :

- excessive mains voltage or
- excessive brake energy,

the fault OUE "overvoltage" is displayed. In the case of excessive brake energy, the deceleration times T_{if} and (or) T_{QSP} must be increased. If necessary, install an external brake resistor.

OH1 Overtemperature supply module

The temperature monitoring on the supply module detects overtemperatures of the heat sink, the mains input bridge, the brake chopper and the internal brake resistors. Possible reasons are:

- overload of the supply module (supply module power < total axis module power).
- blower defective or insufficient
- ambient temperature > 45°C.

OH2 Overtemperature heat sink axis module

The heat sink is monitored by a thermal contact. If the fault OH2 is displayed, either the ventilation is not sufficient or defective, or the ambient temperature is > 45°C. Fault reset is only possible after the heat sink temperature has been reduced below 45°C.

EER External TRIP

The voltage at the TRIP-SET input X5 terminal 26 must be $< 5V$. Otherwise, the external TRIP will be set.

SD2 Wire breakage resolver or resolver cable

The electrical resistance of the resolver cables is monitored. If the line resistance is too high due to a line breakage or an interruption in the resolver, fault SD2 "wire breakage" is displayed.

U15 Supply voltage interrupted

Check the Vcc-15V connection X5 terminal 20 for external short circuit.

CCr System fault

Programme sequence error in the micro processor. A system fault occurs with interference in the electronics caused by incorrect screening or non-screened cables or due to ground or earth loops in the wiring. The fault may also occur after short mains interruptions ($t < 1 \text{ min}$) if the controller was switched off while there was another non-acknowledged fault.

Pr Parameter loss

Program sequence error in the microprocessor which is caused by interference in the electronics due to incorrect screening or non-screened cables or ground or earth current loops in the wiring. The interference resulted the loss of the stored parameters. After TRIP reset and before enabling the controller again, a new parameter setting is required.

CEO

Communication error with the automation module. The error occurs when the automation module is activated by C370-1, but the communication is interrupted.

UEr Unknown fault

This fault occurs in the fault memory if the hardware monitoring sets TRIP, however, the software cannot identify the fault (e.g. in case of interrupted supply voltage).

2. LED displays

The LED displays clearly indicate the momentary operating state of the controller even from greater distances. The axis modules are provided with 3 LEDs in the operating terminal, the supply has 2 LEDs at the front side.

2.1. LED supply module

RDY Ready to operate

The LED is illuminated after the ON-delay has passed and no fault was detected. RDY is not illuminated if a fault was detected.

BR_{on} Brake chopper active

The LED is illuminated if the DC bus voltage is increased above a threshold by absorbing regenerated energy and then dissipated through the brake resistor.

2.2. LED axis module

RDY Ready to operate

The LED is illuminated if the ON-delay has passed and no fault was detected. RDY is not illuminated if a fault was detected or homing is not finished or the DC bus control is active or a following error is active.

I_{max}

The LED is illuminated when reaching the maximum controller current or the set torque limit.

IMP

Pulse inhibit. The LED is illuminated if the inverter is inhibited. The inverter is inhibited if the terminal 28 is low the STOP key is pressed, inhibit activated by communication or if a fault is detected.

| RDY | I_{max} | IMP | |
|------------|------------------------|------------|---|
| on | off | off | Controller is ready to operate, the controller is enabled |
| on | off | on | Controller is ready to operate, however, it is not enabled |
| on | on | off | Speed controller is limited: the controller supplies the set maximum current First commissioning: If the motor speed remains at 50...300 rpm even at high set value and low load, the motor connection cables U and V must be exchanged. |
| off | off | on | Controller is not ready to operate. In case of fault, the type of fault is displayed. |
| off | off | off | Maximum following error, homing not finished, active DC - bus control (see above) |
| off | on | off | The maximum following error occurred at master frequency coupling and the controller reaches the set current limit. |

3. Checking the power stage

The measurements described below are to be carried out only by skilled specialists. Use a digital voltmeter. The measuring values indicate the nominal value. If they are different from your measurements, there is a defect.

3.1. Checking the mains rectifier

- Disconnect the controller from the mains.

Caution!

Wait 5 minutes until the DC-bus is discharged no load!

- Measure directly at the power terminals.

| Measurement | Measuring point | Measuring value |
|-----------------------------|-----------------|----------------------|
| Diodes in forward direction | L1 → +UG | ≈ 0.4V |
| | L2 → +UG | ≈ 0.4V |
| | L3 → +UG | ≈ 0.4V |
| | -UG → L1 | ≈ 0.4V |
| | -UG → L2 | ≈ 0.4V |
| | -UG → L3 | ≈ 0.4V |
| Diodes in reverse direction | +UG → L1 | high resistance (OL) |
| | +UG → L2 | high resistance (OL) |
| | +UG → L3 | high resistance (OL) |
| | L1 → -UG | high resistance (OL) |
| | L2 → -UG | high resistance (OL) |
| | L3 → -UG | high resistance (OL) |

3.2. Checking the output stage

- Disconnect the controller from the mains.

Caution!

Wait 5 minutes until the DC-bus is discharged!

- Measure directly at the power terminals.

| Measurement | Measuring point | Measuring value |
|-------------------------------------|-----------------|-----------------|
| Inverter diode in forward direction | U → +UG | ≈ 0.4V |
| | V → +UG | ≈ 0.4V |
| | W → +UG | ≈ 0.4V |
| Inverter diode in reverse direction | UG → U | high resistance |
| | UG → V | high resistance |
| | UG → W | high resistance |
| Inverter diode in forward direction | -UG → U | ≈ 0.4V |
| | -UG → V | ≈ 0.4V |
| | -UG → W | ≈ 0.4V |
| Inverter diode in reverse direction | U → -UG | high resistance |
| | V → -UG | high resistance |
| | W → -UG | high resistance |



Index

A

- Acceleration time** 48
- Acceptance**
 - direct** 41
 - On-line** 41
 - with SH + PRG** 41
 - with SH + PRG with controller inhibit** 42
- Ambient temperature 6
- Amplification of the angle controller** 56
- Amplification of the difference component of the speed controller** 49
- Analog set value selection** 22
- Angle offset** 56
- Automation interface 71
- Axis module 7

B

- Basic parameter setting 45
- Baud rate** 58
- Brake chopper active** 78
- Brake resistor
 - external 33
- Brake resistor
 - external 18
 - internal 20

C

- CEO** 77
- Change parameters 41
- Checking the mains rectifier 79
- Checking the output stage 79
- Code table 63
- Commissioning 45
- cos ϕ motor** 47

D

- DC-bus control 50
- Deceleration time** 48
- Diagnosis 58

E

- Earth fault** 74
- Electromagnetic compatibility 14
- Electromagnetic compatibility 14
- EMC 14
- Enclosure 6
- Encoder simulation** 25
- Extended code set 41
- External Trip** 77

F

- Following error** 74
- Fuses 34

G

- Gain adjustment** 49
- Gearbox factor 46

H

- Homing mode** 56

I

- Installation
 - electrical 11
 - mechanical 10

Integral action time of the speed controller 49

Interference immunity 34

K

Keypad control 45

L

LCD display 40

LECOM1 58

LECOM2 58

LECOM-LI 59

LED

Axis module 78

Supply module 78

M

Mains and DC-bus monitoring 20

Mains connection 17

Mains failure detection 50
activation 51

Mains isolation 14, 15, 59

Mains status 20

Mains voltage 6

Master frequency 46

Master frequency provision 46

Master frequency selection 24

Maximum current 48

Maximum speed 48

Monitoring 58

Monitoring messages 74

Motor connection 17

Motor nameplate data 47

Motors 39

N

Noise immunity 6

O

ON-LINE 41

Optical fibres 59

Overload axis module 75

Overtemperature heat sink 76

Overtemperature supply module 76

Overvoltage 76

P

Parameter setting 40, 41, 58

Password 45

Peak power 6

Permanent brake power 18

Planning 5

Pollution strength 6

Power connections 17

Power stage 79

Q

Quick stop deceleration time 48

R

Rated motor current 47

Rated motor frequency 47

Rated motor speed 47

Ready to operate 78

relative humidity 6

Resolver 25

RFI filter 34

RS 232 C 58

RS 485 58

S

Save parameters 42

Screening 14

serial communication 60

Setting of speed controller 49

Short circuit 74

Standard code set 45

State bus 21

Supply modules 6
Supply voltage interrupted 77
Switch-on display 57
System cables 34
 for control terminal block 34
 for power supply 37
 for resolver 36
 supply of fan and brake 38
System fault 77
Systemcables
 for master frequency selection 35

T

Table of attributes 60
Terminal control 45
TRIP setting 74

U

Undervoltage 74
Unknown fault 77

W

Wire breakage resolver 77