

Exclusive for headlight angle detection with high accuracy and space-saving design

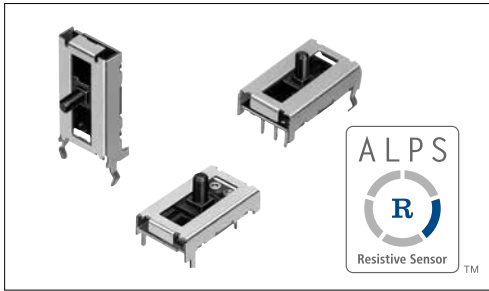

Typical Specifications



Items	Specifications
Rated Voltage	12V DC
Operating life	2N max.
Total resistance	100,000 cycles
Operating temperature range	-40°C to +105°C

Product Line

Travel (mm)	Mounting method	Total resistance (k Ω)	Linearity	Minimum order unit (pcs.)		Model No.	Drawing No.
				Japan	Export		
8	Vertical type	4.7	±1%	2,000	4,000	RD708A029A	1
	Horizontal type	5		1,500	3,000	RD7081015A	2
9				Horizontal type	1,800	3,600	RD7091008A
12	Vertical type	2.2		2,000	4,000	RD712A028A	1
	Horizontal type	10		1,800	3,600	RD7121008A	4

Note

For linearity, various specifications will be available, depending on the applications. Please consult with us when placing your orders.

Packing Specifications



Tray

Model No.	Mounting method	Number of packages (pcs.)		Export package measurements (mm)
		1 case /Japan	1 case /export packing	
RD708	Vertical	2,000	4,000	527×363×215
	Horizontal	1,500	3,000	507×363×216
RD709		Horizontal	1,800	3,600
RD712	Vertical	2,000	4,000	527×363×118
	Horizontal	1,800	3,600	507×363×216

Refer to P.466 for product specifications.
Refer to P.467 for soldering conditions.

■ Dimensions

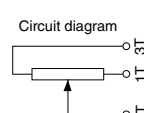
Unit:mm

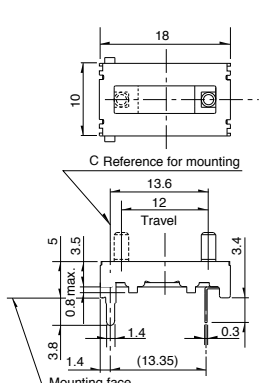
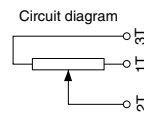
No.	Photo	Style												
1	<p>RD708A RD712A</p> 	  <table border="1" data-bbox="1085 582 1404 705"> <thead> <tr> <th>Dimension Model</th> <th>S</th> <th>A</th> <th>B</th> </tr> </thead> <tbody> <tr> <td>RD708A</td> <td>8</td> <td>15</td> <td>3.4</td> </tr> <tr> <td>RD712A</td> <td>12</td> <td>19</td> <td>3.8</td> </tr> </tbody> </table>	Dimension Model	S	A	B	RD708A	8	15	3.4	RD712A	12	19	3.8
Dimension Model	S	A	B											
RD708A	8	15	3.4											
RD712A	12	19	3.8											
2	<p>RD7081</p> 	 												
3	<p>RD7091</p> 	 												
4	<p>RD7121</p> 	 												

Resistive
Position Sensors

Rotary Type

Linear Type