

# L-force *Servo motors*

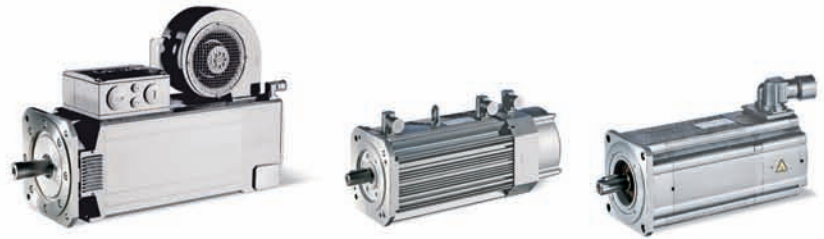

Dynamic, powerful and compact

**NEW**

MCA 9 kW - 53.8 kW  
MQA 10.6 kW - 60.2 kW

**Lenze**

**This is what we stand for.**

You want to implement your machine and plant concepts efficiently and easily or optimise existing concepts to reduce costs? Then, Lenze is the partner you are looking for. For more than 60 years, drive and automation systems have been our core competence.

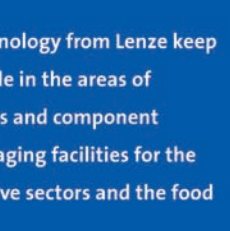
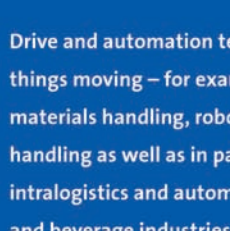
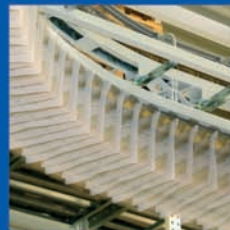

Drive and automation technology from Lenze keep things moving – for example in the areas of materials handling, robotics and component handling as well as in packaging facilities for the intralogistics and automotive sectors and the food and beverage industries.

# Lenze | about us

We can offer you automation solutions including control, visualisation and drive technology from a single source. Our drive systems will improve the performance of your machines. From project planning to commissioning, we have the know-how, whilst our international sales and service network can provide you with expert help and advice at any time.

Cut your process costs and increase your ability to compete. Let us analyse your drive technology tasks and support you with made-to-measure solutions. We can take an integrated approach to projects thanks to the scalability of our products and the scope of the overall portfolio. We can get the best from your machines and systems.

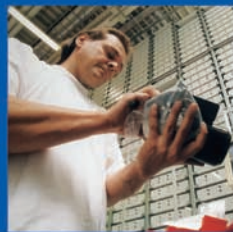

At your side all over the world – with thorough and professional support from our motivated team.

# System overview | L-force Servo motors

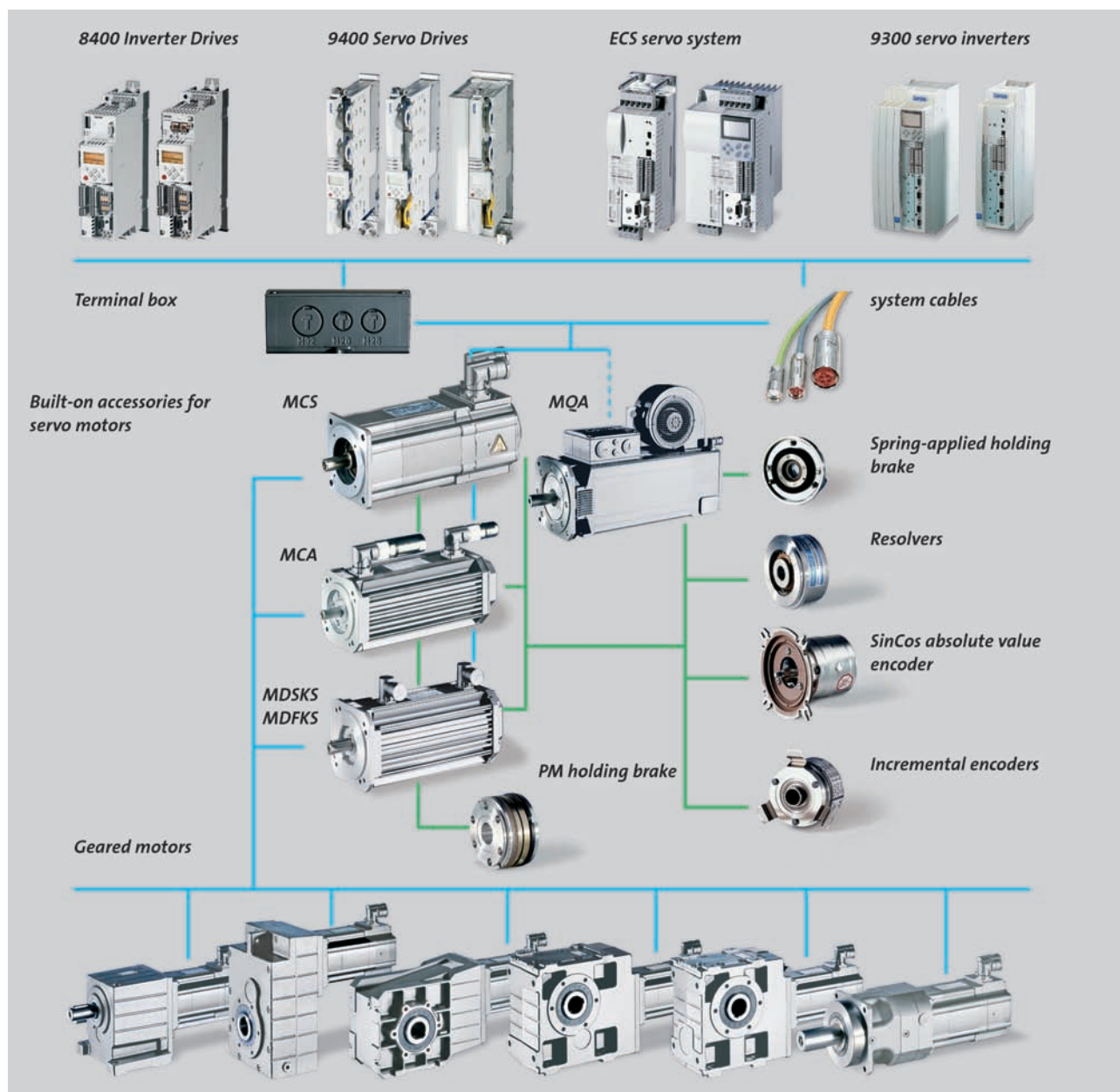

## Other catalogues

In this catalogue, servo motors are described. The other components of the above system overview can be found in the following catalogues:

Components	
Servo Drives 9400	Catalogue: Servo Drives 9400
ECS servo system	Catalogue: ECS servo system
9300 servo inverter	Catalogue: 9300 servo inverters
Geared servo motors	Catalogue: G-motion servo MC
Inverter Drives 8400	Catalogue: L-force Inverter Drives 8400

# Overview | L-force Servo motors

**Contents** ..... 6



**General information** ..... 14



**Drive dimensioning** ..... 29



**MCS synchronous servo motors** ..... 45



**MD□KS synchronous servo motors** ..... 137



**MCA asynchronou servo motors** ..... 165



**MQA asynchronous servo motors** ..... 225



**MDFQA asynchronous servo motors** ..... 249

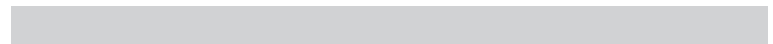

**System cables** ..... 263



**Lenze world-wide** ..... 282

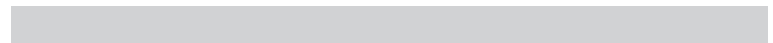

# Contents | L-force Servo motors



## General information

Product key	
MCS synchronous servo motors	14
MCA asynchronous servo motors	16
MQA asynchronous servo motors	18
MD□KS synchronous servo motors	20
MDFQA asynchronous servo motors	21
Product information	
Servo motors	22
About this catalogue	24
List of abbreviations	25
Standards and operating conditions	27

## Drive dimensioning

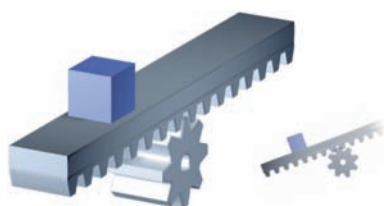

Servo motor designs	
MCS synchronous servo motors	29
MD□KS synchronous servo motors	30
MCA asynchronous servo motors	31
MQA/MDFQA asynchronous servo motors	33
Cooling effect of mounting flange	34
Vibration severities	34
Concentricity and axial run-out of the mounting flanges and smooth running of the shaft ends	35
Definitions	
Notes on the selection tables	40
Notes on the torque characteristics	41
Influence of ambient temperature and site altitude	43

## MCS synchronous servo motors



Rated data	
Mains connection 3x 400 V	45
Mains connection 3x 230 V	50
Permissible radial and axial forces	52
9400 Servo Drives selection tables	
Mains connection 3x 400 V	54
Mains connection 3x 230 V	60
Selection tables for Inverter Drives 8400 TopLine	
Mains connection 3x 400 V	62
ECS servo system selection tables	
Mains connection 3x 400 V	72
Mains connection 3x 230 V	78
EVS9300 servo inverter selection tables	
Mains connection 3x 400 V	80
Torque characteristics	
Mains connection 3x 400 V	86
Mains connection 3x 230 V	113
Accessories	
Motor connection terminal box	123
Holding brakes	124
Holding brake data	125
Blower data	126
Resolver	127
Incremental encoder and SinCos absolute value encoder	128
Thermal sensor	129
Dimensions [mm]	
Motors without blower	131
Motors with blower	134
Motors with terminal box	136

## MD□KS synchronous servo motors



Rated data	
Mains connection 3x 400 V	137
Permissible radial and axial forces	138
9400 Servo Drives selection tables	
Mains connection 3x 400 V	139
Selection tables for Inverter Drives 8400 TopLine	
Mains connection 3x 400 V	141
ECS servo system selection tables	
Mains connection 3x 400 V	143
EVS9300 servo inverter selection tables	
Mains connection 3x 400 V	145
Torque characteristics	
Mains connection 3x 400 V	147
Accessories	
Motor connection terminal box	151
Holding brakes	152
Holding brake data	153
Blower data	155
Resolver	156
Incremental encoder and SinCos absolute value encoder	157
Thermal sensor	158
Dimensions [mm]	
Motors without blower	160
Motors with blower	162
Motors with terminal box	164



## MCA asynchronou servo motors



Rated data	
Mains connection 3x 400 V	165
Permissible radial and axial forces	168
9400 Servo Drives selection tables	
Mains connection 3x 400 V	170
Selection tables for Inverter Drives 8400 TopLine	
Mains connection 3x 400 V	174
ECS servo system selection tables	
Mains connection 3x 400 V	180
EVS9300 servo inverter selection tables	
Mains connection 3x 400 V	182
Torque characteristics	
Mains connection 3x 400 V	186
Accessories	
Motor connection terminal box	205
Holding brakes	206
Holding brake data	207
Blower data	209
Resolver	210
Incremental encoder and SinCos absolute value encoder	211
Safety SinCos incremental encoder	212
Thermal sensor	213
Dimensions [mm]	
Motors without blower	214
Motors with blower, MCA13...19/21	216
Motors with terminal box, MCA10...19/21	218
Motors with blower, MCA20/22/26, B3	220
Motors with blower, MCA20/22/26, B5	222

## MQA asynchronous servo motors

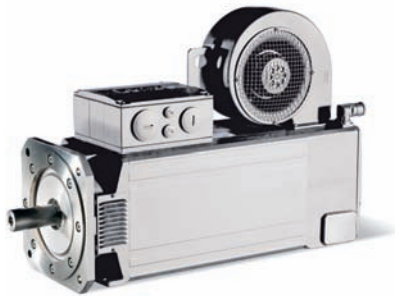

Rated data	
Mains connection 3x 400 V	225
Permissible radial and axial forces	226
9400 Servo Drives selection tables	
Mains connection 3x 400 V	228
Selection tables for Inverter Drives 8400 TopLine	
Mains connection 3x 400 V	230
EVS9300 servo inverter selection tables	
Mains connection 3x 400 V	231
Torque characteristics	
Mains connection 3x 400 V	232
Accessories	
Holding brakes	237
Holding brake data	238
Blower data	239
Resolver	240
Incremental encoder and SinCos absolute value encoder	241
Safety SinCos incremental encoder	242
Thermal sensor	243
Dimensions [mm]	
Motors with blower, B3	244
Motors with blower, B5	246

## MDFQA asynchronous servo motors



Rated data	
Mains connection 3x 400 V	249
Permissible radial and axial forces	250
9400 Servo Drives selection tables	
Mains connection 3x 400 V	251
EVS9300 servo inverter selection tables	
Mains connection 3x 400 V	252
Torque characteristics	
Mains connection 3x 400 V	253
Accessories	
Holding brakes	255
Holding brake data	256
Blower data	257
Resolver	258
Incremental encoder and SinCos absolute value encoder	259
Thermal sensor	260
Dimensions [mm]	261

# Contents | L-force Servo motors



## System cables

Notes	263
Assignment of socket to servo motor	264
Product key	
Motor connecting cables	268
Feedback connecting cables	270
Blower connecting cables	273
Motor extensions	275
Feedback extensions	276
Blower extensions	278

---

Lenze world-wide	282
------------------	-----

---

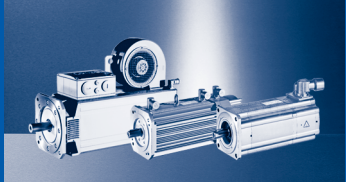

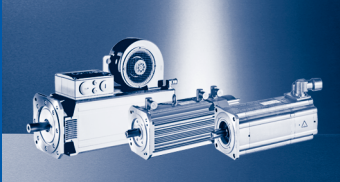

# General information

## Product key

### MCS synchronous servo motors

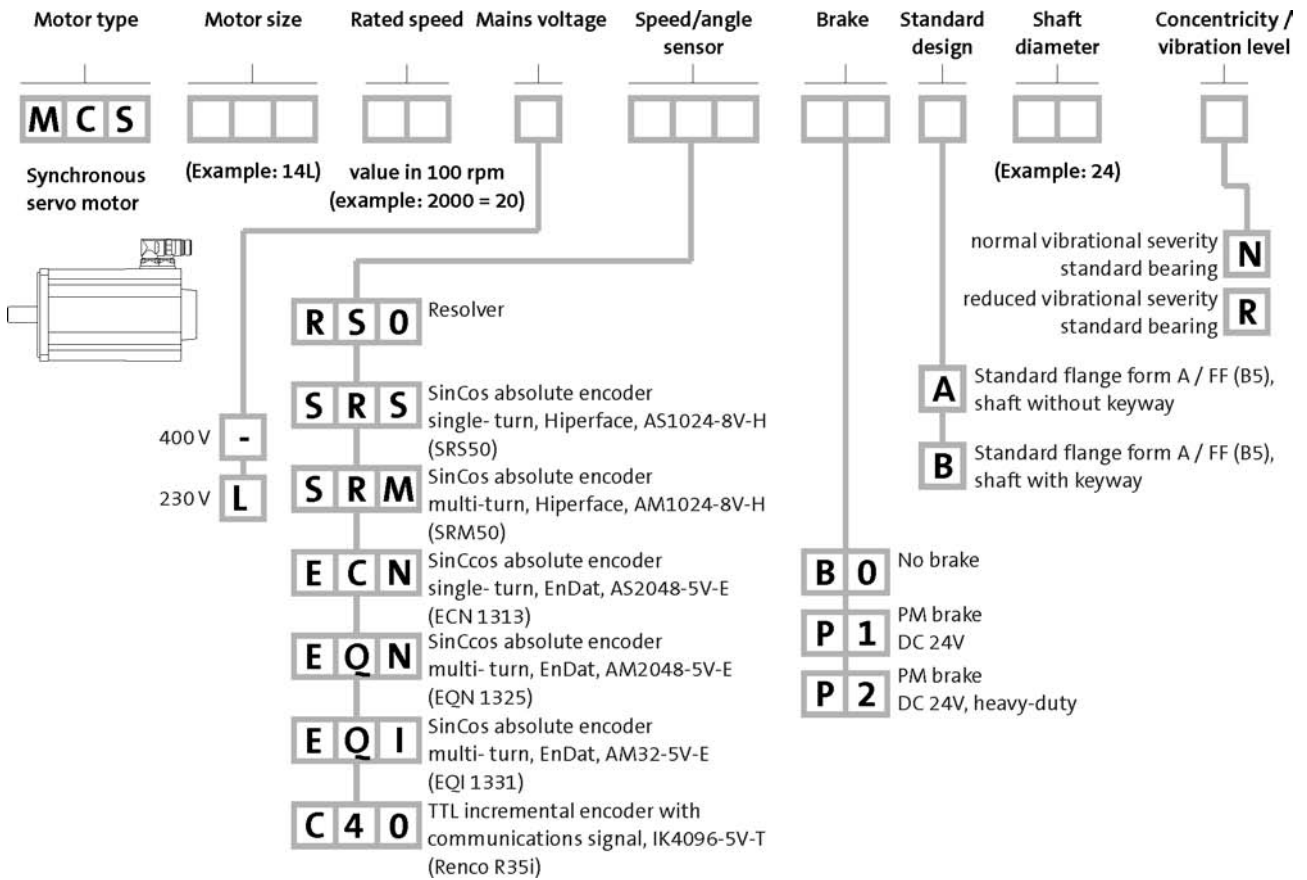

1

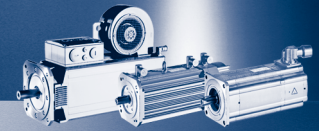

MCS synchronous servo motors

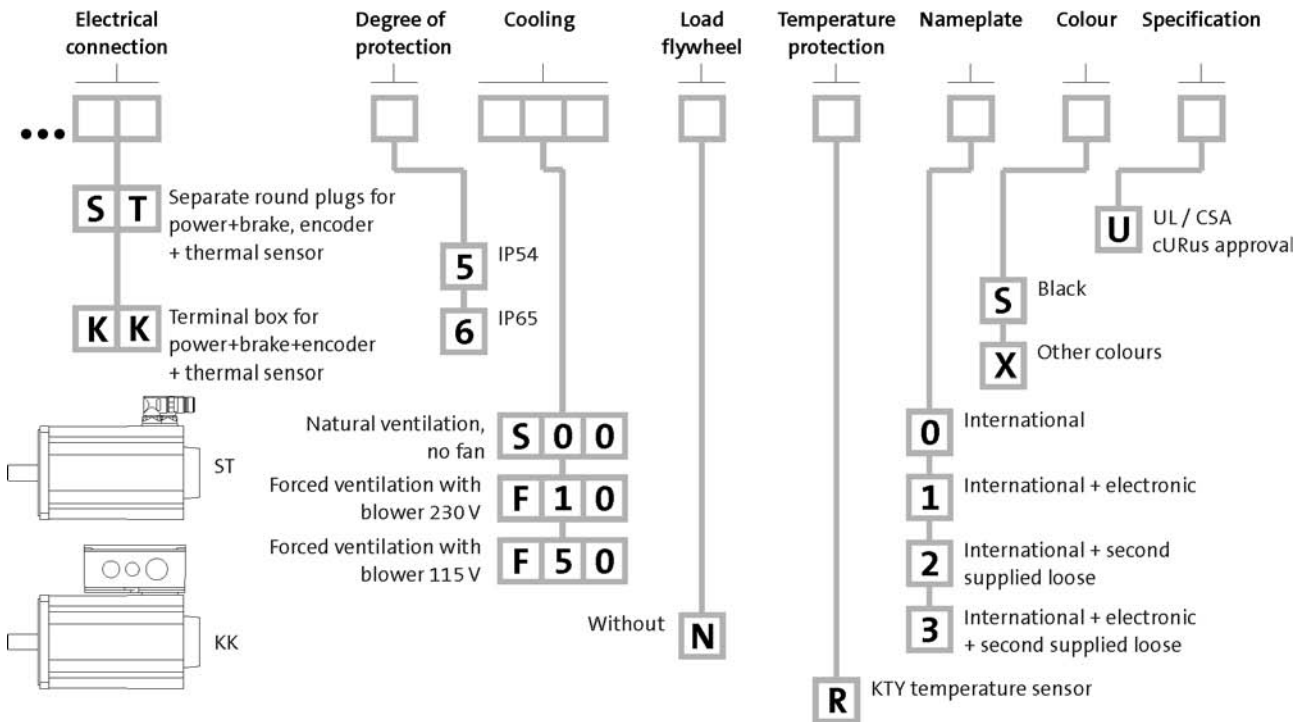

1

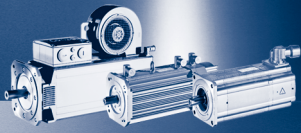

# General information

## Product key

### MCA asynchronous servo motors

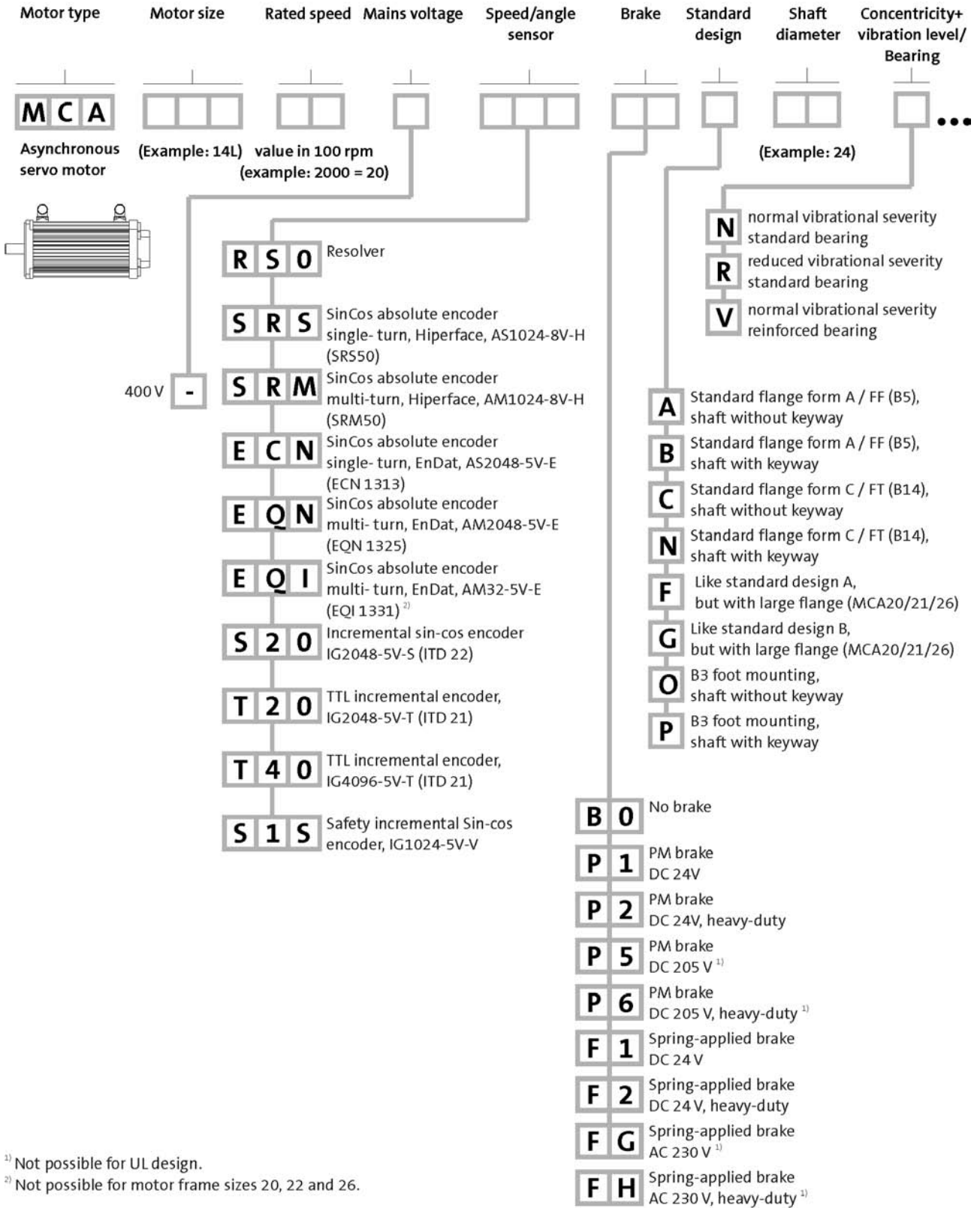

<sup>1)</sup> Not possible for UL design.

<sup>2)</sup> Not possible for motor frame sizes 20, 22 and 26.



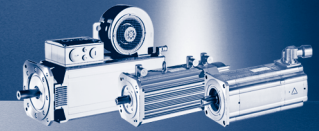

MCA asynchronou servo motors

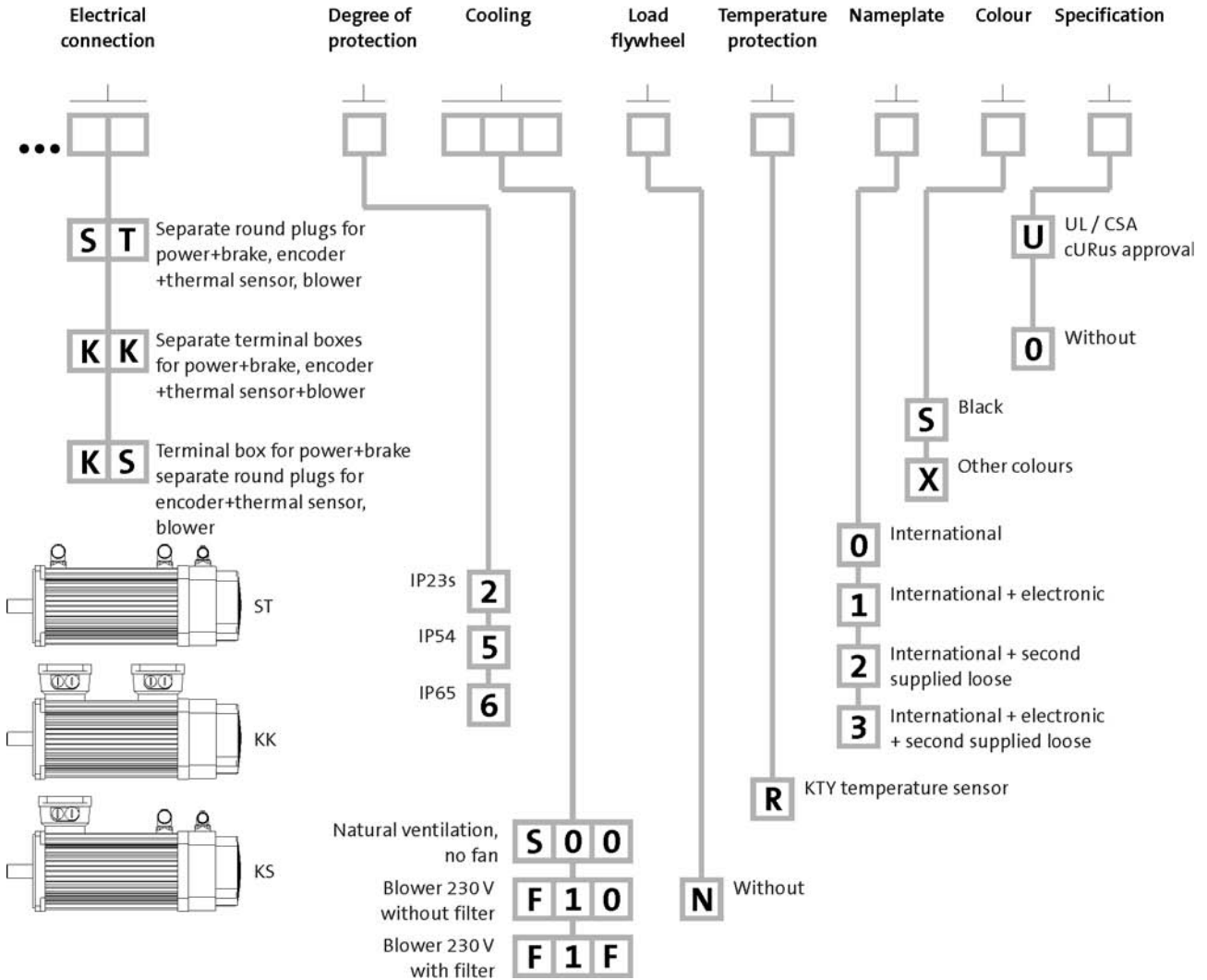

1

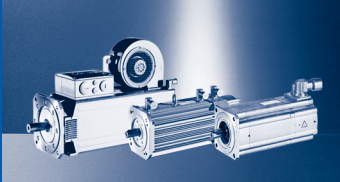

# General information

## Product key

### MQA asynchronous servo motors

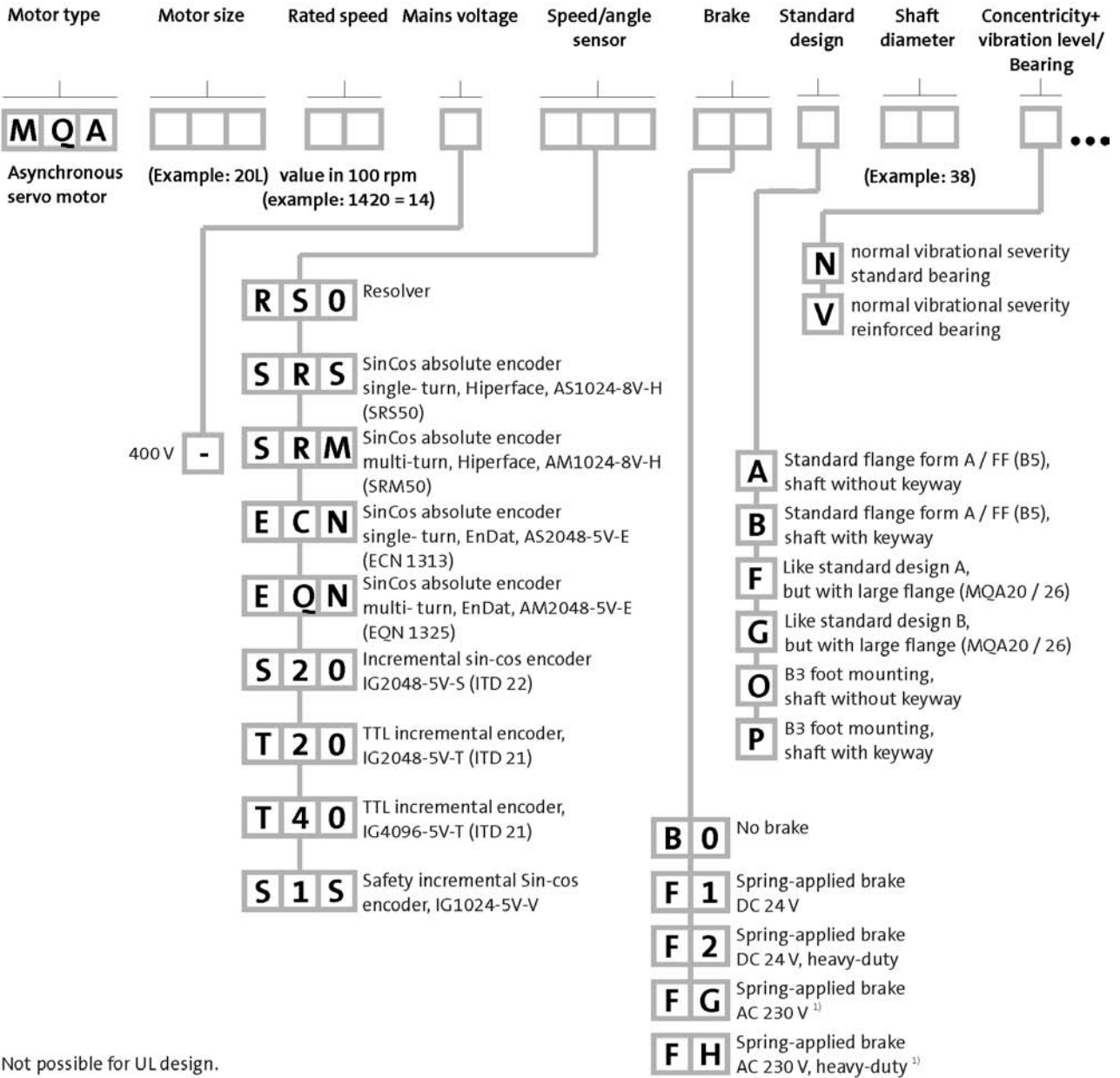

<sup>1)</sup> Not possible for UL design.

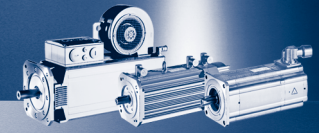

MQA asynchronous servo motors

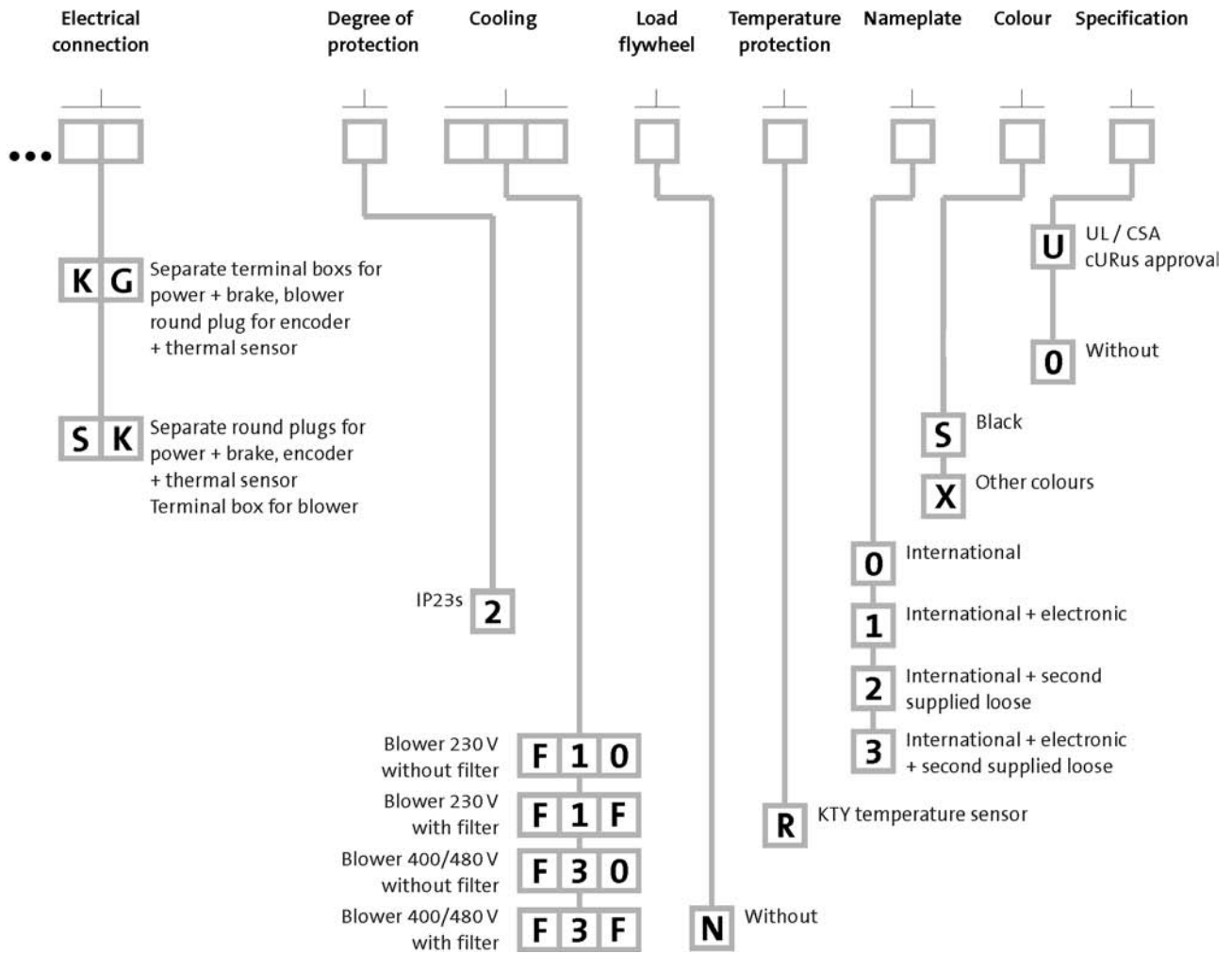

1

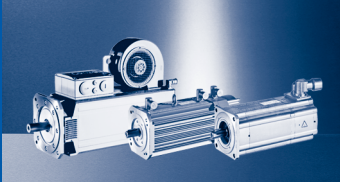

# General information

## Product key

### MDKS synchronous servo motors

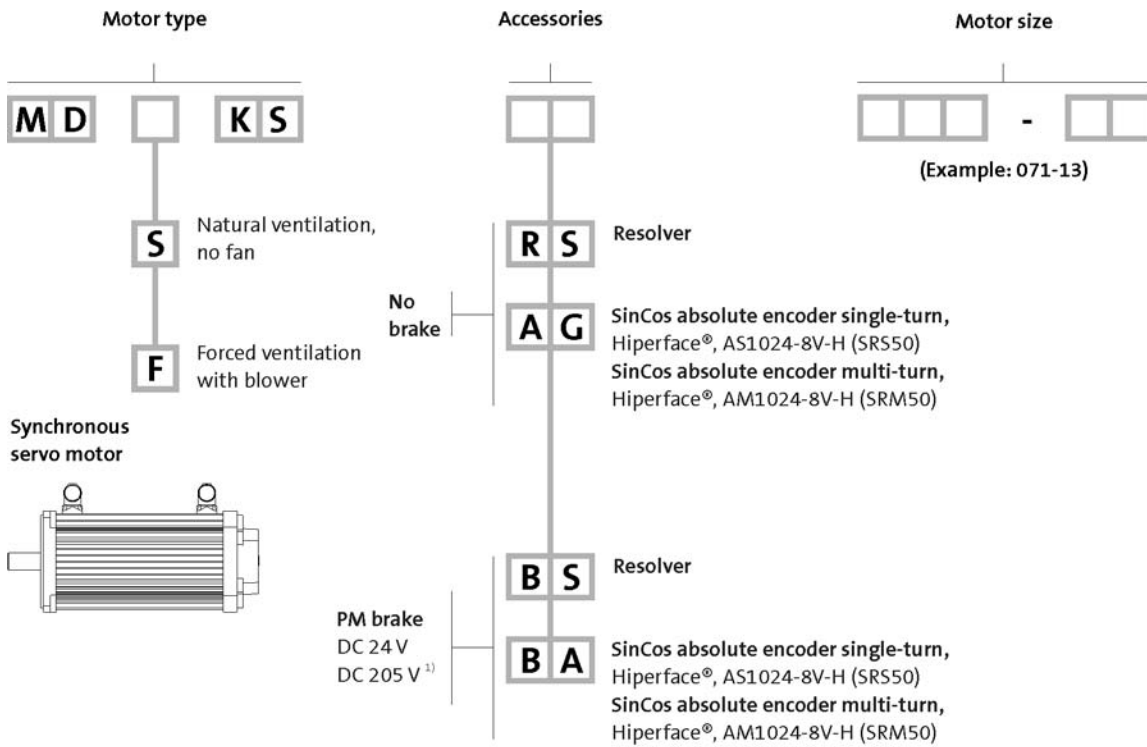

<sup>1)</sup> Not possible for UL design.

Ordering details checklist	
Product key	MDSKS... / MDFKS...
Built-on accessories: brake	Without/24 V DC/205 V DC
Motor design	B14 / B5 design
Shaft design	with/without keyway
Enclosure	IP54 / IP65
Motor connection	Plug connector/terminal box...
Colour	RAL 9005 (jet black) / RAL...

→  30 - Servo motor designs

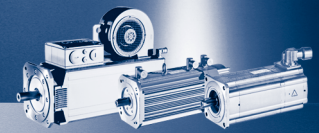

## MDFQA asynchronous servo motors

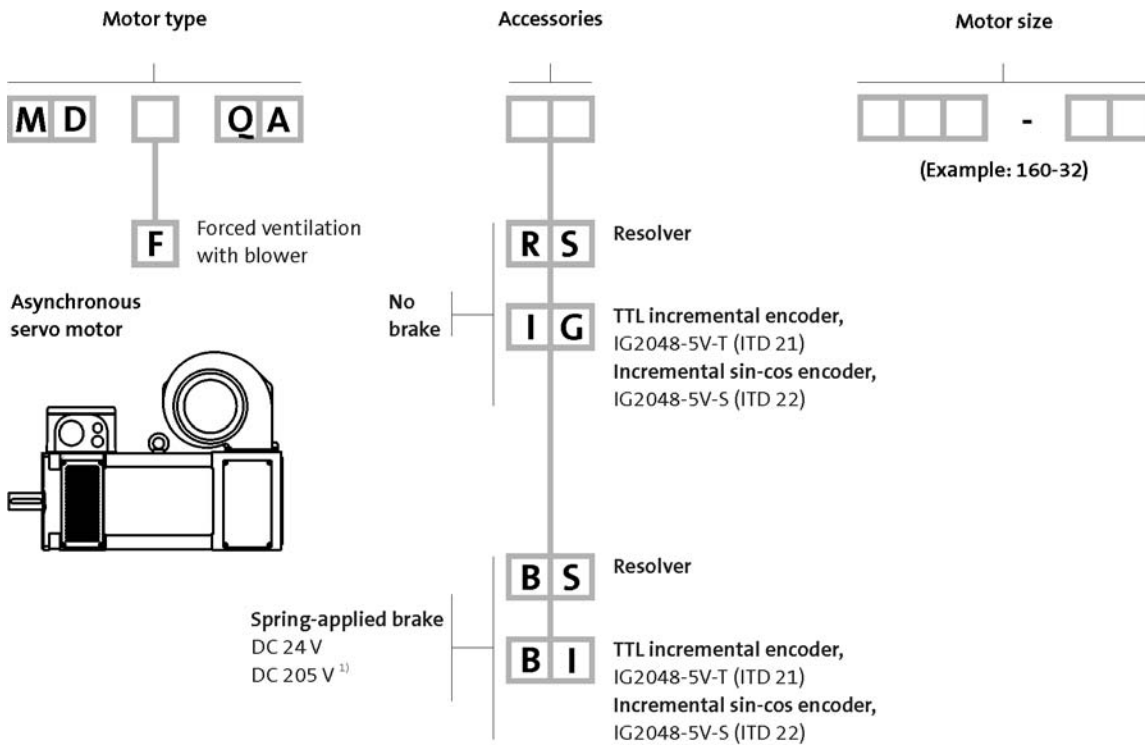

<sup>1)</sup> Not possible for UL design.

Ordering details checklist	
Product key	MDFQA...
Built-on accessories: brake	Without/24 V DC/205 V DC
Built-on accessories: Blower	G2D120 without filters ...
Motor design	B35 / B5 design
Shaft design	with/without keyway
Colour	RAL 9005 (jet black) / RAL...

→ 33 - Servo motor designs

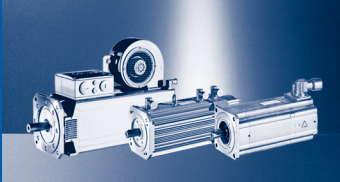

## Servo motors

Today servo drive systems are subjected to the most stringent demands. The differing drive components all have to complement each other perfectly. The Lenze servo motors have an important role to play in this system. Tailored to the various applications, synchronous and asynchronous motors that have been optimised to satisfy the various requirements in terms of dynamic response, accuracy and drive behaviour, are available across a wide torque and power range.

### Dynamic

All servo motors are characterised by a low moment of inertia and a high overload capacity. Continuous temperature measurement using an integrated thermal sensor means that a largely temperature-independent optimum control behaviour is achieved. In combination with the servo inverters, high speed accuracy, the best smooth running characteristics and high angular accelerations can be achieved.

### Precise

In combination with the specially designed neodymium iron boron (NdFeB) high-energy magnets, the new SEpT design (Single Element Pole Technology) enables a distortion-free, entirely sinusoidal working field to be generated on MCS synchronous servo motors. This ensures both excellent smooth running characteristics (due to the absence of field distortion) and maximum power density (as the working field is generated almost entirely from the induced energy). This optimised field form also eliminates practically all distorting cogging and latching torques.

### Long-lived

The high quality level demanded of the components used meets the requirements made on modern drive technology in respect of operational reliability and service life. A reinforced insulation system with thermal reserve (enamel-insulated wire complying with temperature class H, utilisation according to F) ensures a long service life of the winding. In addition, the winding of MCS servo motors is best protected by the full stator encapsulation, even when exposed to severe vibrations, and the heat can be even better dissipated. This increases the load capacity and ensures a long, trouble-free service life. Pre-stressed and generously dimensioned roller bearings with high-temperature resistant grease further guarantee a long bearing service life.

### Reliable in operation

The IP54 degree of protection design ensures good protection against dust and water for the motors in the MCS, MD□KS and MCA series. Where enhanced requirements are made on the protection of the drive, the naturally ventilated design MCS, MD□KS and MCA motors can also be supplied to IP65.

### CE conformity

Naturally, all servo motors comply with EU directives:

- ▶ CE conformity with the Low Voltage Directive
- ▶ CE conformity with the EMC Directive for a typical drive configuration with inverter

Compliance with electromagnetic compatibility can be guaranteed quite simply by using pre-assembled system cables.

### UL certification

All servo motors are prepared for use on the continent of America. MCS, MCA and MQA series servo motors are cURus certified, MDSKS, MDFKS and MDFQA series motors are UR certified. (Exception: version with the 205 V brake.)

### No compromises in terms of output speed

The wide ratio range of Lenze gearboxes, combined with the small ratio step of 1.12, allows the required output speed range to be chosen very precisely. The ability to connect the gearboxes directly in the case of the servo motors in the MCS, MD□KS and MCA series produces an extremely compact drive unit with a minimal volume. It goes without saying that all servo motors can also be combined with gearboxes in the conventional manner.

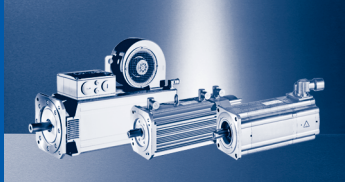

### Adaptable

The modular design of the motors and the variants make it easier to make the correct choice for the application case concerned.

The drives are a match for practically any drive task thanks to the variety of output-side designs of the motors and geared motors:

- ▶ Servo motor with round shaft end with or without keyway
- ▶ Geared servo motors with solid shaft, hollow shaft or hollow shaft with shrink disc
- ▶ Geared servo motors with or without flange, foot or centring
- ▶ Different integrated angle sensors allow adaptation to the desired accuracy: resolver as a standard solution with optimised behaviour thanks to internal improvement of the resolver accuracy, sincos absolute value encoder for the greatest accuracy or even incremental encoder for general applications.
- ▶ Matched to the motor type concerned, permanent magnet or spring-applied holding brakes with different torque ranges ensure exact positioning in all application cases, even when the drive is deenergised.

### Bold

The high chopper frequencies of the servo inverters (up to 16 kHz) and a cleverly designed magnetic circuit result in extremely low noise levels. Optimised gear teeth geometry in the Lenze gearboxes prevents noise developing, while the internally ribbed cast iron gearbox housing also helps reduce noise levels.

### Compact

The high power density of all servo motors permits small, highly dynamic drive units. The use of geared servo motors with direct mounting of the motors leads to particularly compact drives.

### Reduced backlash

The use of backlash-free permanent magnet holding brakes allows a position to be held precisely, even if the drive is deenergised.

Backlash-free connecting elements in the Lenze gearboxes and the high quality of the teeth thanks to precision manufacturing result in extremely low output backlash on the servo geared motors in comparison with comparable gearboxes. All servo motors in the MCS and MCA 10...19 / 21 series can be combined with directly mounted GPA series planetary gearboxes to meet the highest requirements on reduced backlash.

Here too, just as with all our motor-gearbox combinations, we consistently use friction-type connections which will also reliably cope with highly dynamic servo applications.

### Special types

We can also provide special models tailored to meet the requirements of specific applications.

### Easy to install

All Lenze servo motors are guaranteed to be extremely easy to install, with short down times whenever one needs to be replaced. All connections on the MCS, MD□KS and MCA motors are keyed to prevent incorrect connection and can be turned through about 320° to allow them to be fitted and removed easily in all situations.



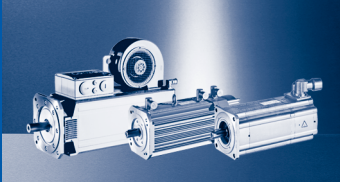

### About this catalogue

This catalogue brings together all the synchronous servo motors in the MCS, MDSKS, MDFKS and the asynchronous servo motors in the MCA, MQA, MDFQA series. The motor-inverter combinations are listed for the default settings for the servo inverters. All further possible assignments can be downloaded from the Internet.

The same product range is also covered in the electronic DSC catalogue. The electronic catalogue is available on DVD and on the Internet at [www.lenze.de/dsc](http://www.lenze.de/dsc).

On the Internet you can also find and download a PDF containing additional information such as torque characteristics for the individual motor inverter combinations. Various operating modes, e.g. different maximum currents at different switching frequencies, are listed.

#### **Please observe the Drive Dimensioning chapter.**

Here you will find general data, designs and definitions (references to the assignment tables).

#### **To ensure rapid and correct delivery we require:**

- ▶ your delivery data such as delivery date and delivery address
- ▶ the complete product key of our products. Please also take note of the ordering details checklist for the MD□KS and MDFQA series of servo motor.

A list of Lenze sales offices can be found at the end of this catalogue.



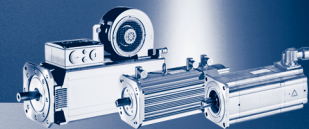

## List of abbreviations

$\eta_{100\%}$	[%]	Efficiency
$\cos \varphi$		Power factor
$du / dt$	[kV / $\mu$ s]	Insulation resistance
$F_{ax,-}$	[N]	Min. axial force
$F_{ax,+}$	[N]	Max. axial force
$f_{in,max}$	[Hz]	Max. input frequency
$f_{max}$	[kHz]	Limit frequency
$f_{max}$	[kHz]	Max. switching frequency
$f_N$	[Hz]	Rated frequency
$F_{rad}$	[N]	Max. radial force
$H_{max}$	[m]	Site altitude
$I_0$	[A]	Standstill current
$I_{max}$	[A]	Max. short-time DC-bus current
$I_{max}$	[A]	Max. current
$I_{max}$	[A]	Max. current consumption
$I_{max}$	[A]	Max. current
$I_{max}$	[A]	Max. DC-bus current
$I_N$	[A]	Rated current
$J$	[kgcm <sup>2</sup> ]	Moment of inertia
$J_{MB}$	[kgcm <sup>2</sup> ]	Moment of inertia
$KE_{LL 150\text{ }^\circ\text{C}}$	[V /1000 rp]	Voltage constant
$Kt_{0 150\text{ }^\circ\text{C}}$	[Nm/A]	Torque constant
$L$	[mH]	Mutual inductance
$L_{1\sigma}$	[mH]	Stator leakage inductance
$L_{2\sigma}$	[mH]	Rotor leakage inductance
$L_N$	[mH]	Rated inductance
$m$	[kg]	Mass
$M_0$	[Nm]	Stall torque
$M_{0,max}$	[Nm]	Max. standstill torque
$M_{av}$	[Nm]	Average dynamic torque
$M_{max}$	[Nm]	Max. torque
$M_N$	[Nm]	rated torque
$n_k$	[r/min]	Speed
$n_{max}$	[r/min]	Max. speed

$n_N$	[r/min]	Rated speed
$P_N$	[kW]	Rated power
$Q_E$	[J]	Maximum switching energy
$R$	[ $\Omega$ ]	Insulation resistance
$R$	[ $\Omega$ ]	Min. insulation resistance
$R_1$	[ $\Omega$ ]	Stator impedance
$R_2$	[ $\Omega$ ]	Charging resistor
$R_2$	[ $\Omega$ ]	Rotor impedance
$R_{UV 150\text{ }^\circ\text{C}}$	[ $\Omega$ ]	Stator impedance
$R_{UV 20\text{ }^\circ\text{C}}$	[ $\Omega$ ]	Stator impedance
$S_{h\u00fc}$	[1/h]	Transition operating frequency
$T$	[ $^\circ\text{C}$ ]	Operating temperature
$T$	[ $^\circ\text{C}$ ]	Rated temperature
$T$	[ $^\circ\text{C}$ ]	Max. ambient temperature of bearing
$T$	[ $^\circ\text{C}$ ]	Max. surface temperature
$T$	[ $^\circ\text{C}$ ]	Max. ambient temperature for transport
$T$	[ $^\circ\text{C}$ ]	Min. ambient storage temperature
$T$	[ $^\circ\text{C}$ ]	Min. ambient temperature for transport
$T$	[ $^\circ\text{C}$ ]	Ambient temperature
$t_1$	[ms]	Engagement time
$t_2$	[ms]	Disengagement time
$T_{opr,max}$	[ $^\circ\text{C}$ ]	Max. ambient operating temperature
$T_{opr,min}$	[ $^\circ\text{C}$ ]	Min. ambient operating temperature
$U_{in,max}$	[V]	Max. input voltage
$U_{in,min}$	[V]	Min. input voltage
$U_{max}$	[V]	Max. mains voltage
$U_{max}$	[V]	Min. input voltage
$U_{min}$	[V]	Min. mains voltage
$U_{N, AC}$	[V]	Rated voltage
$U_{N, DC}$	[V]	Rated voltage
$Z_{ro}$	[ $\Omega$ ]	Rotor impedance
$Z_{rs}$	[ $\Omega$ ]	Impedance
$Z_{so}$	[ $\Omega$ ]	Stator impedance

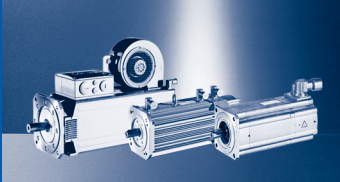

## General information

### Product information

CE	Communauté Européenne
CSA	Canadian Standards Association
DIN	Deutsches Institut für Normung e.V.
EMC	Electromagnetic compatibility
EN	European standard
IEC	International Electrotechnical Commission
IM	International Mounting Code
IP	International Protection Code
NEMA	National Electrical Manufacturers Association
UL	Underwriters Laboratory Listed Product
UR	Underwriters Laboratory Recognized Product
VDE	Verband deutscher Elektrotechniker (Association of German Electrical Engineers)

1



			MCS		MDSKS		MDFKS	
<b>Cooling type</b>			Naturally ventilated	Blower	Naturally ventilated		Blower	
<b>Enclosure</b> EN 60529			IP54 IP65	IP54	IP54 IP65		IP54	
<b>Temperature class</b> IEC/EN 60034-1; utilisation IEC/EN 60034-1; insulation system (enamel-insulated wire)					F			
					H			
<b>Approval</b> Class			cURus <sup>1)</sup> GOST-R		GOST-R UR <sup>1)</sup>			
<b>Max. voltage load</b> IEC/TS 60034-25			Limit curve A of pulse voltage (Fig. 14)					
<b>Smooth running</b> IEC 60072			Normal class					
<b>Axial run-out</b> IEC 60072			Normal class					
<b>Concentricity</b> IEC 60072			Normal class					
<b>Mechanical ambient conditions (vibration)</b> IEC/EN 60721-3-3			3M6					
<b>Min. ambient operating temperature</b> Without brake	$T_{opr,min}$	[°C]	-20	-15	-20	-15		
With brake	$T_{opr,min}$	[°C]			-10			
<b>Max. ambient operating temperature</b>	$T_{opr,max}$	[°C]	40					
<b>Max. surface temperature</b>	T	[°C]	140	110	140	110		
<b>Mechanical tolerance</b> Flange centring diameter			$b_2 \leq 230 \text{ mm} = j6$ $b_2 > 230 \text{ mm} = h6$					
Shaft diameter			$d \leq 50 \text{ mm} = k6$ $d > 50 \text{ mm} = m6$					
<b>Site altitude</b> Amsl	$H_{max}$	[m]	4000					
power reduction above 1000 m		[%/1000 m]	5.00					

<sup>1)</sup> Recognized component File No. E 210321.

# General information

## Standards and operating conditions

			MCA	MQA	MDFQA
<b>Cooling type</b>			Naturally ventilated	Blower	
<b>Enclosure</b> EN 60529			IP54 IP65	IP54 IP23s <sup>2)</sup>	IP23s
<b>Temperature class</b> IEC/EN 60034-1; utilisation IEC/EN 60034-1; insulation system (enamel-insulated wire)			F H		
<b>Approval</b> Class			cURus <sup>4, 6)</sup> GOST-R		GOST-R UR <sup>5)</sup>
<b>Max. voltage load</b> IEC/TS 60034-25			Limit curve A of pulse voltage (Fig. 14)		
<b>Smooth running</b> IEC 60072			Precision class <sup>1)</sup> Normal class	Normal class	
<b>Axial run-out</b> IEC 60072			Precision class <sup>1)</sup> Normal class	Normal class	
<b>Concentricity</b> IEC 60072			Precision class <sup>1)</sup> Normal class	Normal class	
<b>Mechanical ambient conditions (vibration)</b> IEC/EN 60721-3-3			3M6		
<b>Min. ambient operating temperature</b> Without brake With brake	$T_{opr,min}$ $T_{opr,min}$	[°C] [°C]	-20	-15 -10	
<b>Max. ambient operating temperature</b>	$T_{opr,max}$	[°C]	40		
<b>Max. surface temperature</b>	T	[°C]	140	110	
<b>Mechanical tolerance</b> Flange centring diameter  Shaft diameter			$b_2 \leq 230 \text{ mm} = j6$ $b_2 > 230 \text{ mm} = h6$ $d \leq 50 \text{ mm} = k6$ $d > 50 \text{ mm} = m6$		
<b>Site altitude</b> Amsl power reduction above 1000 m	$H_{max}$	[m] [%/1000 m]	4000 5.00		

<sup>1)</sup> MCA14, 17, 19 and 21.

<sup>2)</sup> MCA20, 22 and 26.

<sup>3)</sup> Not possible on MCA20.

<sup>4)</sup> Recognized component File No. E 210321.

<sup>5)</sup> MDFQA160: on request, Recognized component File No. E 217551.

<sup>6)</sup> MCA20X29, MCA21X35, MQA20L29 with plug connector motor connection UR only



### MCS synchronous servo motors

	MCS06	MCS09	MCS12	MCS14	MCS19
<b>Type</b>	B5-FF75	B5-FF100	B5-FF130	B5-FF165	B5-FF215
<b>Shaft end (with and without keyway)</b>	11 x 23	14 x 30	19 x 40	24 x 50	28 x 60
<b>A end shield</b>	Not oil-tight				
<b>Brake</b> Permanent magnetic brake	DC 24 V	DC 24 V 24 V DC, reinforced			
<b>Speed and angle encoder</b>	Resolver SinCos single-turn/multi-turn				
<b>Cooling</b> Without blower Axial blower, 1 phase	Naturally ventilated		230 V; 50 Hz 115 V; 60 Hz		
<b>Temperature sensor</b> Thermal detector PTC thermistor	KTY 2x PTC additional (3-phase monitoring)				
<b>Motor connection: plug connector</b>	Power + brake Encoder + thermal sensor		Power + brake Encoder + thermal sensor Blower		
<b>Motor connection: terminal box</b>	Power + brake + encoder + thermal sensor				
<b>Shaft bearings</b> Bearing type Position of the locating bearing	Deep-groove ball bearing with high-temperature resistant grease, sealing disc or cover plate Non-drive end				
<b>Colour</b>	RAL9005M				

► Terminal boxes not possible if blower is fitted.

### MD□KS synchronous servo motors

	MDSKS□□056	MDSKS□□071	MDFKS□□071
<b>Type</b>	B14-FT85 B5-FF100		B14-FT130 B5-FF130
<b>Shaft end (with and without keyway)</b>	14 x 30		19 x 40
<b>A end shield</b>	Not oil-tight		
<b>Brake</b> Permanent magnetic brake	DC 24 V AC 230 V <sup>1)</sup> DC 205 V <sup>1)</sup>		
<b>Speed and angle encoder</b>	Resolver SinCos single-turn/multi-turn		
<b>Cooling</b> Without blower Axial blower, 1 phase	Naturally ventilated		230 V; 50 Hz
<b>Temperature sensor</b> Thermal detector	KTY		
<b>Motor connection: plug connector</b>	Power + brake Encoder + thermal sensor		Power + brake Encoder + thermal sensor Blower
<b>Motor connection: terminal box</b>	Power + brake Encoder + thermal sensor		Power + brake Encoder + thermal sensor + blower
<b>Motor connection: Terminal box + plug connector</b> Terminal box	Power + brake Encoder + thermal sensor		
Plug connector			Blower
<b>Shaft bearings</b> Bearing type Position of the locating bearing	Deep-groove ball bearing with high-temperature resistant grease, sealing disc or cover plate Drive end		
<b>Colour</b>	RAL9005M		

<sup>1)</sup> Not possible for UR version.



### MCA asynchronou servo motors

	MCA10	MCA13	MCA14	MCA17	MCA19
<b>Type</b>	B14-FT85 B5-FF100	B14-FT130 B5-FF130	B14-FT130 B5-FF165		B14-FT130 B5-FF215
<b>Shaft end (with and without keyway)</b>	14 x 30	19 x 40	24 x 50		28 x 60
<b>A end shield</b>	Not oil-tight Oil-tight				
<b>Brake</b> Spring-applied brake Permanent magnetic brake	DC 24 V AC 230 V <sup>1)</sup> DC 205 V <sup>1)</sup>				
<b>Speed and angle encoder</b>	Resolver SinCos single-turn/multi-turn Incremental encoder				
<b>Cooling</b> Without blower Axial blower, 1 phase	Naturally ventilated 230 V; 50 Hz				
<b>Temperature sensor</b> Thermal detector	KTY				
<b>Motor connection: plug connector</b>	Power + brake Encoder + thermal sensor Blower				
<b>Motor connection: terminal box</b>	Power + brake Encoder + thermal sensor	Power + brake Encoder + thermal sensor + blower			
<b>Motor connection: Terminal box + plug connector</b> Terminal box Plug connector		Power + brake Encoder + thermal sensor			Blower
<b>Shaft bearings</b> Bearing type Position of the locating bearing Installation of the locating bearing Position of the locating bearing on reinforced design	Deep-groove ball bearing with high-temperature resistant grease, sealing disc or cover plate Drive end				
<b>Colour</b>	RAL9005M				

<sup>1)</sup> Not possible for UR version.

### MCA asynchronou servo motors

	MCA20	MCA21	MCA22	MCA26
<b>Type</b>	B3 B5-FF215 B5-FF265	B14-FT130 B5-FF215 B5-FF265	B3 B5-FF265	B3 B5-FF265 B5-FF350
<b>Shaft end (with and without keyway)</b>	38 x 80			55 x 110
<b>A end shield</b>	Not oil-tight Oil-tight			
<b>Brake</b>				
Spring-applied brake	DC 24 V AC 230 V <sup>1)</sup>			DC 24 V AC 230 V <sup>1)</sup>
Permanent magnetic brake		DC 24 V AC 230 V <sup>1)</sup> DC 205 V <sup>1)</sup>		
<b>Speed and angle encoder</b>	Resolver SinCos single-turn/multi-turn Incremental encoder			
<b>Cooling</b>				
Without blower		Naturally ventilated		
Axial blower, 1 phase	230 V; 50 Hz 230 V; 60 Hz	230 V; 50 Hz		230 V; 50 Hz 230 V; 60 Hz
<b>Temperature sensor</b>				
Thermal detector	KTY			
<b>Motor connection: plug connector</b>				
	Power + brake Encoder + thermal sensor Blower			
<b>Motor connection: terminal box</b>				
		Power + brake Encoder + thermal sensor + blower		
<b>Motor connection: Terminal box + plug connector</b>				
Terminal box	Power + brake	Power + brake Encoder + thermal sensor	Power + brake	
Plug connector	Encoder + thermal sensor Blower	Blower	Encoder + thermal sensor Blower	
<b>Shaft bearings</b>	Deep-groove ball bearing with high-temperature resistant grease, sealing disc or cover plate			
Bearing type				
Position of the locating bearing	Non-drive end	Drive end	Non-drive end	
Installation of the locating bearing	insulation		insulation	
Position of the locating bearing on reinforced design	Drive end		Drive end	
<b>Colour</b>	RAL9005M			

<sup>1)</sup> Not possible for UR version.





### MQA/MDFQA asynchronous servo motors

	MQA20	MQA22	MQA26	MDFQA□□160
<b>Type</b>	B3 B5-FF215 B5-FF265	B3 B5-FF265	B3 B5-FF265 B5-FF350	B35-FF350
<b>Shaft end (with and without keyway)</b>	38 x 80		55 x 110	
<b>A end shield</b>	Not oil-tight Oil-tight			Not oil-tight
<b>Brake</b> Spring-applied brake	DC 24 V AC 230 V <sup>1, 2)</sup>			DC 24 V AC 230 V <sup>1)</sup> DC 205 V <sup>1)</sup>
<b>Speed and angle encoder</b>	Resolver SinCos single-turn/multi-turn Incremental encoder			Without Resolver SinCos single- turn/multi-turn Incremental encoder
<b>Cooling</b> Radial blower, 1 phase	230 V; 50 Hz 230 V; 60 Hz			
Radial blower, 3 phase	400 V; 50 Hz 400 V; 60 Hz 460 V; 50 Hz 460 V; 60 Hz 480 V; 60 Hz			
<b>Temperature sensor</b> Thermal detector	KTY			
Thermal contact	TKO <sup>2)</sup>			
<b>Motor connection: Terminal box + plug connector</b> Terminal box		Power + brake Blower		Power + thermal sensor Blower
Plug connector	Power + brake Encoder + thermal sensor	Encoder + thermal sensor		Brake + encoder
<b>Shaft bearings</b> Bearing type	Deep-groove ball bearing with high-temperature resistant grease, sealing disc or cover plate			
Position of the locating bearing	Non-drive end			
Installation of the locating bearing	insulation			
Position of the locating bearing on reinforced design	Drive end			
<b>Colour</b>	Primed (grey) RAL9005M			

<sup>1)</sup> Not possible for UR version.

<sup>2)</sup> Not possible for MQA motor type with plug connector motor connection.

### Cooling effect of mounting flange

Installation on a thermally conducting/insulating plate or chassis has an influence on how the motors heat up, in particular in the naturally ventilated motors. The influence is slight or negligible in the case of the MQA and MDFQA series servo motors.

The motor rating data stated in the catalogue is valid for installation on a steel plate set up in free convection with the dimensions listed below:

- ▶ MCS06: 270 x 270 mm
- ▶ MCS09: 330 x 330 mm
- ▶ MCS12 / 14 / 19: 450 x 450 mm
- ▶ MDSKS□□036 / 056 / 071: 270 x 270 mm
- ▶ MCA10 / 13: 270 x 270 mm
- ▶ MCA14 / 17: 330 x 330 mm
- ▶ MCA19 ... 26: 450 x 450 mm

### Vibration severities

		MCS06	MCS09	MCS12	MCS14	MCS19
<b>Vibrational severity</b> IEC/EN 60034-14				A		
Maximum r.m.s. value of the vibration velocity <sup>1)</sup>	[mm/s]			1.60		

		MDSKS□□036	MDSKS□□056	MDSKS□□071	MDFKS□□071
<b>Vibrational severity</b> IEC/EN 60034-14				A	
Maximum r.m.s. value of the vibration velocity <sup>1)</sup>	[mm/s]			1.60	

		MCA10	MCA13	MCA14	MCA17	MCA19	MCA20	MCA21	MCA22	MCA26
<b>Vibrational severity</b> IEC/EN 60034-14		A			B		A	B		A
Maximum r.m.s. value of the vibration velocity <sup>1)</sup>	[mm/s]	1.60			0.70		1.60	0.70		1.60

		MQA20	MQA22	MQA26	MDFQA□□160
<b>Vibrational severity</b> IEC/EN 60034-14				A	
Maximum r.m.s. value of the vibration velocity <sup>1)</sup>	[mm/s]			1.60	

- ▶ at n = 600...3600 r/min

<sup>1)</sup> Free suspension



## Concentricity and axial run-out of the mounting flanges and smooth running of the shaft ends

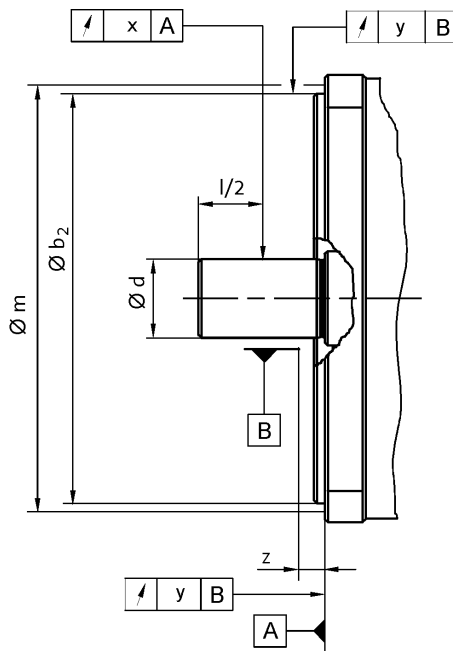

				MCS06	MCS09	MCS12	MCS14	MCS19
<b>Flange size</b>				FF75	FF100	FF130	FF165	FF215
<b>Dimensions</b>	$b_2$	j6	[mm]	60	80	110	130	180
	$d$	k6	[mm]	11	14	19	24	28
<b>Distance</b>	$m$		[mm]	65.0	85.0	115	135	185
	$z$	+/- 1	[mm]			10.0		
<b>Concentricity</b>						Normal class		
IEC 60072								
Value	$y$		[mm]	0.080			0.10	
<b>Axial run-out</b>						Normal class		
IEC 60072								
Value	$y$		[mm]	0.080			0.10	
<b>Smooth running</b>						Normal class		
IEC 60072								
Value	$x$		[mm]	0.035			0.040	

- Limit values for checking the smooth running of the shaft ends as well as the concentricity and axial run-out of the mounting flange to IEC 60072

### Concentricity and axial run-out of the mounting flanges and smooth running of the shaft ends

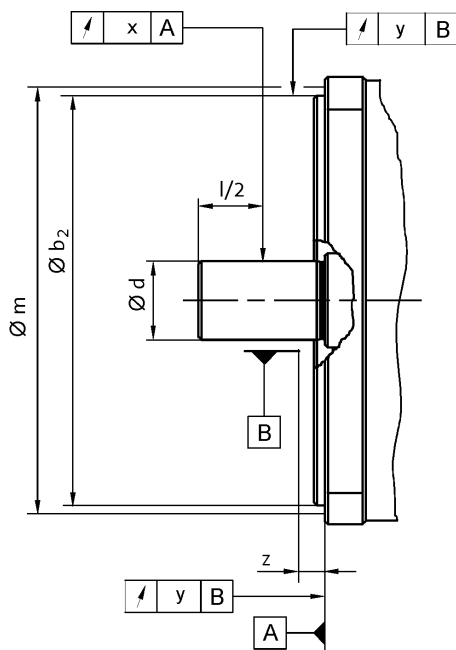

				MDSKS□□036		MDSKS□□056		MDSKS□□071		MDFKS□□071	
<b>Flange size</b>				FF75	FF100	FT85	FF130	FT130	FF130	FT130	
<b>Dimensions</b>	$b_2$	j6	[mm]	60	80	70			110		
	$d$	k6	[mm]	11	14				19		
<b>Distance</b>	Measuring diameter	$m$	[mm]	86.0	113	98.0			149		
	Dial gauge holder for flange check	$z$	+/- 1 [mm]					10.0			
<b>Concentricity</b>	IEC 60072							Normal class			
	Value	$y$	[mm]	0.080						0.10	
<b>Axial run-out</b>	IEC 60072							Normal class			
	Value	$y$	[mm]	0.080						0.10	
<b>Smooth running</b>	IEC 60072							Normal class			
	Value	$x$	[mm]	0.035						0.040	

- Limit values for checking the smooth running of the shaft ends as well as the concentricity and axial run-out of the mounting flange to IEC 60072



## Concentricity and axial run-out of the mounting flanges and smooth running of the shaft ends

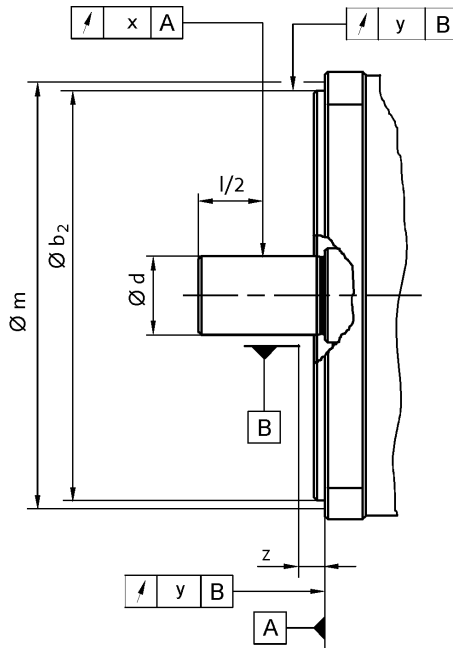

				MCA10		MCA13		MCA14		MCA17		MCA19	
Flange size				FF100	FT85	FF130	FT130	FF165	FT130	FF165	FT130	FF215	FT130
Dimensions	$b_2$	j6	[mm]	80	70	110		130	110	130	110	180	110
	$b_2$	h6	[mm]										
	$d$	k6	[mm]	14		19			24				28
	$d$	m6	[mm]										
Distance													
Measuring diameter	$m$		[mm]	113	98.0	149		188	149	188	149	239	149
Dial gauge holder for flange check	$z$	$\pm 1$	[mm]					10.0					
Concentricity IEC 60072				Normal class				Precision class					
Value	$y$		[mm]	0.080		0.10						0.050	
Axial run-out IEC 60072				Normal class				Precision class					
Value	$y$		[mm]	0.080		0.10						0.050	
Smooth running IEC 60072				Normal class				Precision class					
Value	$x$		[mm]	0.035		0.040						0.021	

- Limit values for checking the smooth running of the shaft ends as well as the concentricity and axial run-out of the mounting flange to IEC 60072

# Drive dimensioning

## Servo motor designs

				MCA20		MCA21			MCA22	MCA26	
<b>Flange size</b>				FF215	FF265	FF215	FF265	FT130		FF265	FF350
<b>Dimensions</b>	b <sub>2</sub>	j6	[mm]	180	230	180	230	110		230	
	b <sub>2</sub>	h6	[mm]								300
	d	k6	[mm]			38					
	d	m6	[mm]								55
<b>Distance</b> Measuring diameter Dial gauge holder for flange check	m		[mm]	239	289	239	289	149		289	384
	z	+/- 1	[mm]				10.0				
<b>Concentricity</b> IEC 60072				Normal class		Precision class			Normal class		
	Value	y	[mm]	0.10		0.050			0.10		
<b>Axial run-out</b> IEC 60072				Normal class		Precision class			Normal class		
	Value	y	[mm]	0.10		0.050			0.10		
<b>Smooth running</b> IEC 60072				Normal class		Precision class			Normal class		
	Value	x	[mm]	0.050		0.060			0.050	0.060	

- ▶ Limit values for checking the smooth running of the shaft ends as well as the concentricity and axial run-out of the mounting flange to IEC 60072



**Concentricity and axial run-out of the mounting flanges and smooth running of the shaft ends**

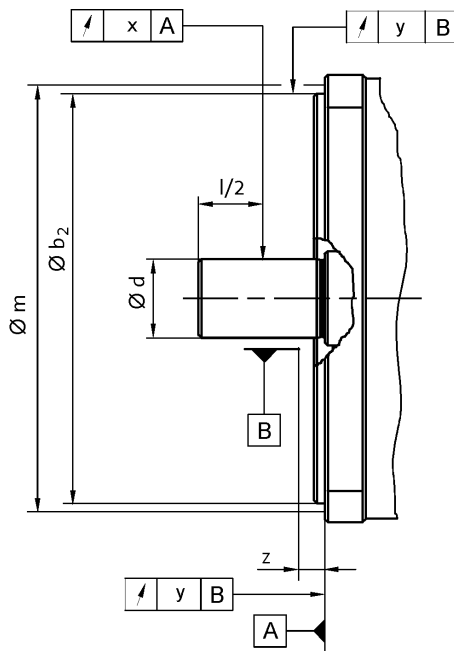

				MQA20	MQA22	MQA26	MD-FQA□□160
<b>Flange size</b>				FF215	FF265		FF350
<b>Dimensions</b>	$b_2$	j6	[mm]	180	230		
	$b_2$	h6	[mm]				300
	$d$	k6	[mm]		38		
	$d$	m6	[mm]			55	
<b>Distance</b>							
Measuring diameter	$m$		[mm]	239	289		384
Dial gauge holder for flange check	$z$	+/- 1	[mm]		10.0		
<b>Concentricity</b>					Normal class		
IEC 60072							
Value	$y$		[mm]		0.10		0.13
<b>Axial run-out</b>					Normal class		
IEC 60072							
Value	$y$		[mm]		0.10		0.13
<b>Smooth running</b>					Normal class		
IEC 60072							
Value	$x$		[mm]	0.050		0.060	

- ▶ Limit values for checking the smooth running of the shaft ends as well as the concentricity and axial run-out of the mounting flange to IEC 60072

### Notes on the selection tables

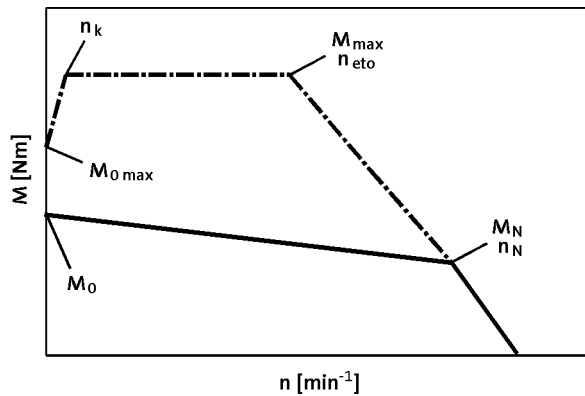

Graphical display of the operating points

#### Please note:

- ▶ Under live load (e.g. vertical drive axes, hoists, test benches, unwinders)  $M_{0\max}$  must be taken into consideration
- ▶ Under passive load (e.g. horizontal drive axes)  $M_{\max}$  can, as a rule, be used
- ▶ With speeds  $< n_k$  the torque  $M_{0\max}$  achievable is less than  $M_{\max}$  depending on the inverter
- ▶ In the case of servo inverters, the switching frequency-dependent overload capacity is taken into consideration at the default setting. For further information, see the Servo inverter catalogue.

	$n_k$
	[r/min]
MCS	75.0
MDSKS	100
MDFKS	100
MCA	150
MQA	150
MDFQA	150

Further selection tables with different switching frequencies are available with the following codes:

- ▶ DS\_ZT\_MCS\_0001
- ▶ DS\_ZT\_MCA\_0001
- ▶ DS\_ZT\_MDSKS\_0001
- ▶ DS\_ZT\_MDFKS\_0001

Simply enter this code (e.g. DS\_ZT\_MCS\_0001) as a search string at [www.lenze.de/dsc](http://www.lenze.de/dsc) and you will be given the information immediately in the form of a PDF format.





### Notes on the torque characteristics

This catalogue contains continuous and limit torque characteristics for synchronous and asynchronous servo motors. You will find characteristics for intermittent operation online at [www.lenze.de/dsc](http://www.lenze.de/dsc).

### Characteristics for synchronous motors

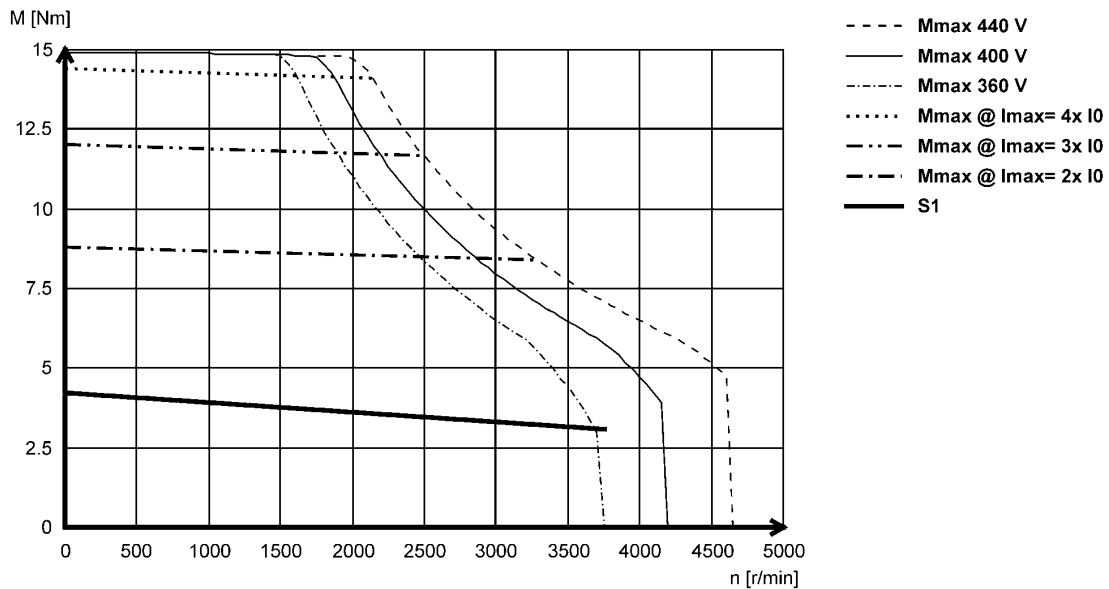

For the synchronous servo motors, both the continuous operation characteristic (S1) and the limit torque characteristic are shown; these result from the selection of servo inverters with maximum currents that correspond to a multiple of the motor standstill current (2x I<sub>0</sub> ... 4x I<sub>0</sub>).

### Characteristics for asynchronous motors

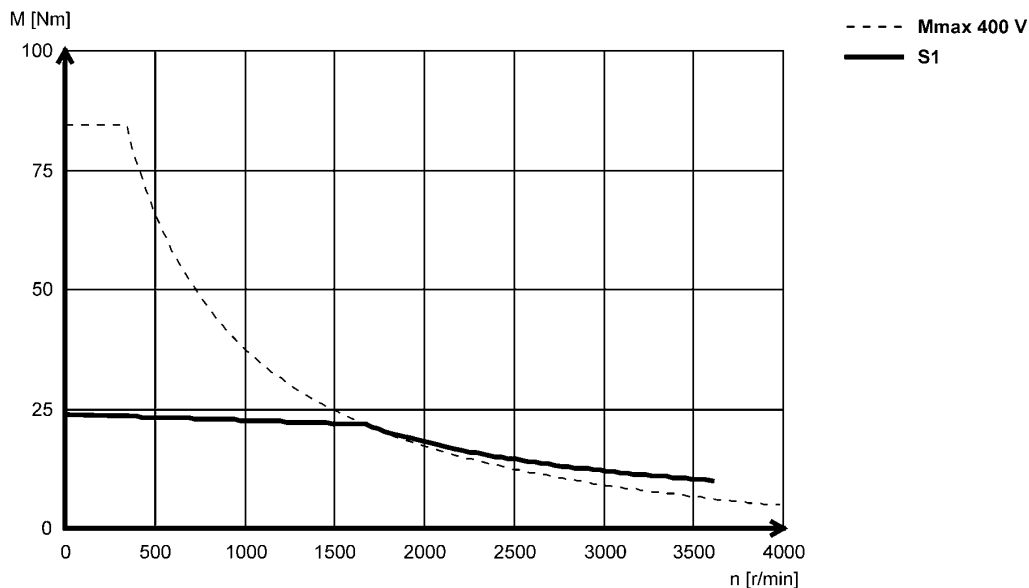

With asynchronous servo motors, two characteristics are shown in each case. The continuous operation characteristic (S1) shows the speed-dependent continuous torque of the motor during operation on a servo inverter running with a constant switching frequency. The limit torque characteristic corresponds to the one produced when operating the motor on the largest possible Servo Drive 9400 in each case (see the selection tables), with the servo inverter set to a variable switching frequency.

### Characteristics in the Internet

The torque characteristics for inverter motor combinations can be found online at [www.lenze.de/dsc](http://www.lenze.de/dsc). This page shows all sensible combinations featuring the servo inverter series 9400, 9300, ECS and Inverter Drives 8400 TopLine. The limiting characteristics are each determined with the inverters' default settings:

- ▶ 9400 with a variable switching frequency.  
In a limit case, this means that up to 6 times the overcurrent can be used.
- ▶ 9300 and ECS with fixed switching frequency.
- ▶ 8400 TopLine and HighLine with variable switching frequency.

The continuous operation characteristics (S1) show the motor rated values regardless of inverter used.

For more information on the terms switching frequency and default setting, please consult the relevant servo inverter operating instructions.



### Influence of ambient temperature and site altitude

The information relating to the servo motors in the tables and graphs is valid for a maximum ambient temperature ( $T_{opr}$ ) of 40 °C and a site altitude ( $H$ ) up to 1000 m above sea level. The torque correction factor ( $k_{M1}$ ) shall be applied to the S1 torque characteristic ( $M_0...M_N$ ) in the event of differing installation conditions.

- ▶ The maximum permissible ambient temperature ( $T_{opr}$ ) for servo motors with blowers is 40 °C

### MCS, MD□KS synchronous servo motors

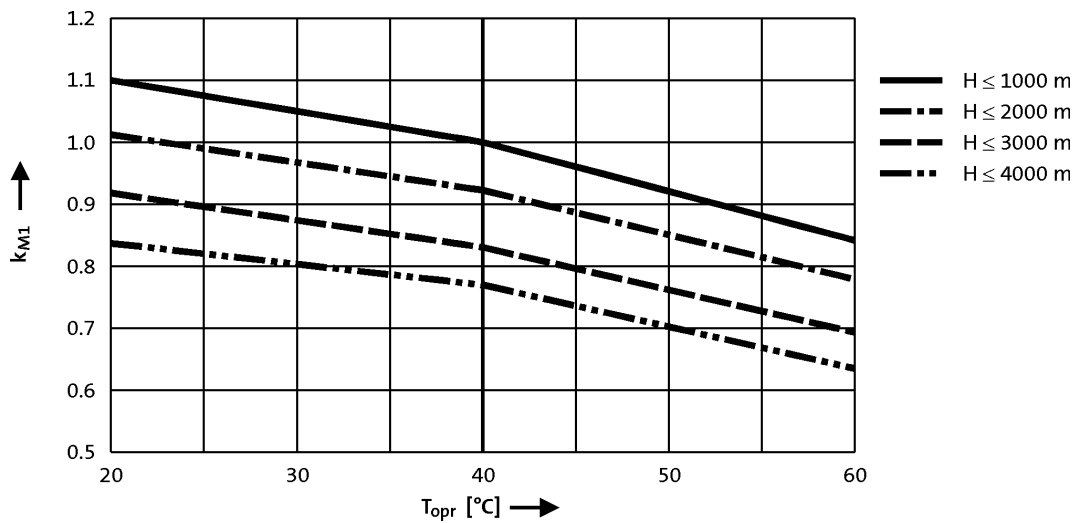

### MCA, MQA, MDFQA asynchronous servo motors

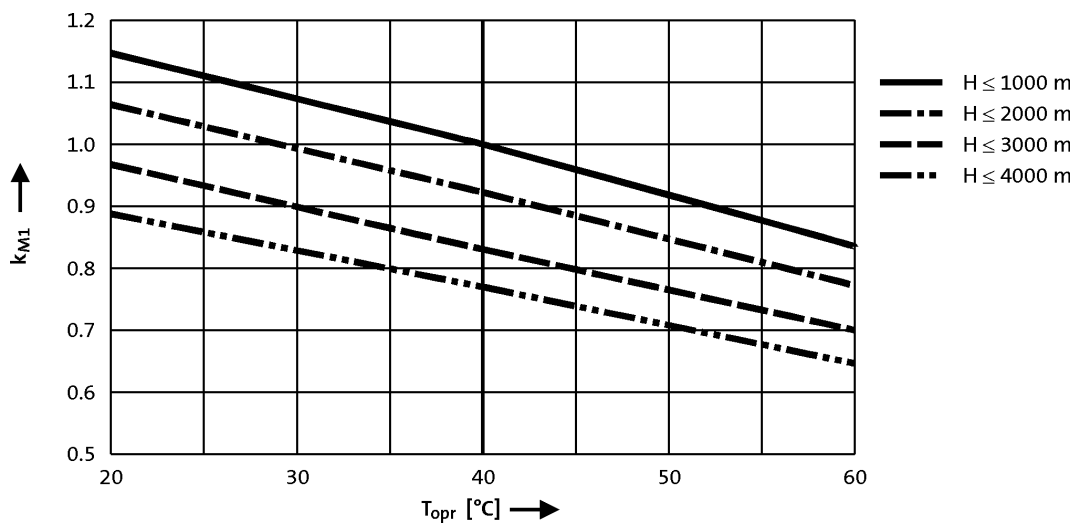



## Drive dimensioning

2

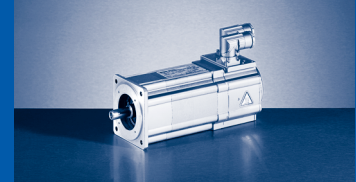

## Mains connection 3x 400 V

### Motors without blower

	$n_N$	$M_0$	$M_{max}$	$M_N$	$P_N$	$I_0$	$I_N$	$I_{max}$	$U_{N,AC}$	$f_N$
	[r/min]	[Nm]	[Nm]	[Nm]	[kW]	[A]	[A]	[A]	[V]	[Hz]
MCS06C41-	4050	0.80	2.40	0.60	0.25	1.30	1.30	5.40	225	270
MCS06C60-	6000	0.80	2.40	0.50	0.31	2.50	2.40	10.8	135	400
MCS06F41-	4050	1.50	4.40	1.20	0.51	1.50	1.50	5.30	320	270
MCS06F60-	6000	1.50	4.40	0.90	0.57	2.90	2.50	10.5	180	400
MCS06I41-	4050	2.00	6.20	1.50	0.64	1.70	1.60	5.90	325	270
MCS06I60-	6000	2.00	6.20	1.20	0.75	3.40	2.90	11.8	190	400
MCS09D41-	4050	3.30	9.50	2.30	1.00	2.60	2.30	10.0	320	270
MCS09D60-	6000	3.30	9.50	1.80	1.10	5.30	3.80	20.0	210	400
MCS09F38-	3750	4.20	15.0	3.10	1.20	3.00	2.50	15.0	330	250
MCS09F60-	6000	4.20	15.0	2.40	1.50	6.00	4.50	30.0	230	400
MCS09H41-	4050	5.50	20.0	3.80	1.60	4.30	3.40	20.0	300	270
MCS09H60-	6000	5.50	20.0	3.00	1.90	8.50	6.00	40.0	190	400
MCS09L41-	4050	7.50	32.0	4.50	1.90	6.20	4.20	32.0	295	270
MCS09L51-	5100	7.50	32.0	3.60	1.90	12.4	6.90	64.0	180	340

	$\eta_{100\%}$	$J^1)$	$KE_{LL 150^\circ C}$	$R_{UV 20^\circ C}$	$R_{UV 150^\circ C}$	$L_N$	$Kt_{0 150^\circ C}$	$n_{max}^2)$	$m^1)$
	[%]	[kgcm <sup>2</sup> ]	[V /1000 rp]	[ $\Omega$ ]	[ $\Omega$ ]	[mH]	[Nm/A]	[r/min]	[kg]
MCS06C41-	65	0.14	36.6	27.1	36.5	51.0	0.66	8000	1.80
MCS06C60-	70	0.14	18.3	6.80	9.10	12.8	0.33	8000	1.80
MCS06F41-	77	0.22	60.1	21.9	29.5	63.5	1.05	8000	2.20
MCS06F60-	81	0.22	30.0	5.50	7.40	15.9	0.53	8000	2.20
MCS06I41-	81	0.30	73.4	18.8	25.4	60.2	1.21	8000	2.90
MCS06I60-	84	0.30	36.7	4.70	6.30	15.1	0.60	8000	2.90
MCS09D41-	87	1.10	71.2	7.00	9.40	25.1	1.25	7000	4.30
MCS09D60-	87	1.10	35.6	1.80	2.40	6.30	0.62	7000	4.30
MCS09F38-	91	1.50	79.8	5.20	7.00	24.6	1.40	7000	5.20
MCS09F60-	91	1.50	39.9	1.30	1.80	6.20	0.70	7000	5.20
MCS09H41-	91	1.90	75.7	3.20	4.30	16.1	1.29	7000	6.10
MCS09H60-	91	1.90	37.8	0.80	1.10	4.00	0.65	7000	6.10
MCS09L41-	91	2.80	71.7	1.80	2.40	9.90	1.21	7000	7.90
MCS09L51-	91	2.80	35.9	0.44	0.59	2.50	0.60	7000	7.90

<sup>1)</sup> Without brake.

<sup>2)</sup> Mechanically permissible maximum speed.

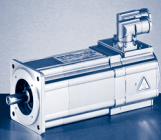

## MCS synchronous servo motors

### Rated data

#### Mains connection 3x 400 V

#### Motors without blower

	$n_N$	$M_0$	$M_{max}$	$M_N$	$P_N$	$I_0$	$I_N$	$I_{max}$	$U_{N,AC}$	$f_N$
	[r/min]	[Nm]	[Nm]	[Nm]	[kW]	[A]	[A]	[A]	[V]	[Hz]
MCS12D20-	1950	6.40	18.0	5.50	1.10	2.70	2.60	10.0	345	130
MCS12D41-	4050	6.40	18.0	4.30	1.80	5.50	4.50	20.0	310	270
MCS12H15-	1500	11.4	29.0	10.0	1.60	4.10	3.80	12.0	300	100
MCS12H35-	3525	11.4	29.0	7.50	2.80	8.20	5.70	24.0	325	235
MCS12L20-	1950	15.0	56.0	13.5	2.80	6.20	5.90	28.0	330	130
MCS12L41-	4050	15.0	56.0	11.0	4.70	12.4	10.2	57.0	300	270
MCS14D15-	1500	11.0	29.0	9.20	1.45	5.00	4.50	17.0	305	100
MCS14D36-	3600	11.0	29.0	7.50	2.80	10.0	7.50	33.0	295	240
MCS14H15-	1500	21.0	55.0	16.0	2.50	8.50	6.60	26.0	325	100
MCS14H32-	3225	21.0	55.0	14.0	4.70	16.9	11.9	52.0	295	215
MCS14L15-	1500	28.0	77.0	23.0	3.60	12.0	9.70	37.0	315	100
MCS14L32-	3225	28.0	77.0	17.2	5.80	24.0	15.0	75.0	275	215
MCS14P14-	1350	37.0	105	30.0	4.20	12.2	10.8	46.0	340	90
MCS14P32-	3225	37.0	105	21.0	7.10	24.3	15.6	92.0	315	215

	$\eta_{100\%}$	$J^1)$	$KE_{LL 150\text{ }^\circ\text{C}}$	$R_{UV 20\text{ }^\circ\text{C}}$	$R_{UV 150\text{ }^\circ\text{C}}$	$L_N$	$Kt_{0 150\text{ }^\circ\text{C}}$	$n_{max}^2)$	$m^1)$
	[%]	[kgcm <sup>2</sup> ]	[V / 1000 rp]	[ $\Omega$ ]	[ $\Omega$ ]	[mH]	[Nm/A]	[r/min]	[kg]
MCS12D20-	79	4.00	137	8.70	11.8	52.2	2.34	6000	6.40
MCS12D41-	84	4.00	68.6	2.20	2.90	13.0	1.17	6000	6.40
MCS12H15-	88	7.30	173	5.70	7.70	42.1	2.79	6000	9.50
MCS12H35-	91	7.30	86.5	1.40	1.90	10.5	1.40	6000	9.50
MCS12L20-	90	10.6	149	2.20	3.00	21.8	2.42	6000	12.6
MCS12L41-	91	10.6	74.6	0.55	0.75	5.50	1.21	6000	12.6
MCS14D15-	88	8.10	129	4.00	5.40	49.8	2.19	6000	10.7
MCS14D36-	92	8.10	64.2	1.00	1.35	12.5	1.09	6000	10.7
MCS14H15-	92	14.2	153	1.94	2.61	34.1	2.48	6000	15.5
MCS14H32-	93	14.2	76.3	0.48	0.65	8.50	1.24	6000	15.5
MCS14L15-	90	23.4	152	1.21	1.64	22.0	2.33	6000	20.1
MCS14L32-	93	23.4	76.2	0.30	0.41	5.50	1.16	6000	20.1
MCS14P14-	90	34.7	179	1.10	1.49	23.9	3.04	6000	24.9
MCS14P32-	93	34.7	89.4	0.28	0.37	6.00	1.52	6000	24.9

<sup>1)</sup> Without brake.

<sup>2)</sup> Mechanically permissible maximum speed.

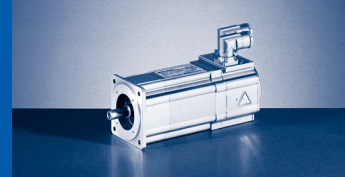

## Mains connection 3x 400 V

### Motors without blower

	$n_N$	$M_0$	$M_{max}$	$M_N$	$P_N$	$I_0$	$I_N$	$I_{max}$	$U_{N,AC}$	$f_N$
	[r/min]	[Nm]	[Nm]	[Nm]	[kW]	[A]	[A]	[A]	[V]	[Hz]
<b>MCS19F14-</b>	1425	32.0	86.0	27.0	4.00	9.90	8.60	31.0	335	95
<b>MCS19F30-</b>	3000	32.0	86.0	21.0	6.60	19.8	14.0	63.0	300	200
<b>MCS19J14-</b>	1425	51.0	129	40.0	6.00	15.2	12.3	45.0	330	95
<b>MCS19J30-</b>	3000	51.0	129	29.0	9.10	30.5	18.5	90.0	300	200
<b>MCS19P14-</b>	1350	64.0	190	51.0	7.20	17.5	14.3	60.0	330	90
<b>MCS19P30-</b>	3000	64.0	190	32.0	10.0	34.9	19.0	120	320	200

	$\eta_{100\%}$	$J^1$	$KE_{LL\ 150\ ^\circ C}$	$R_{UV\ 20\ ^\circ C}$	$R_{UV\ 150\ ^\circ C}$	$L_N$	$Kt_{0\ 150\ ^\circ C}$	$n_{max}^2$	$m^1$
	[%]	[kgcm <sup>2</sup> ]	[V /1000 rp]	[ $\Omega$ ]	[ $\Omega$ ]	[mH]	[Nm/A]	[r/min]	[kg]
<b>MCS19F14-</b>	92	65.0	195	1.30	1.75	20.8	3.23	4000	23.0
<b>MCS19F30-</b>	93	65.0	97.2	0.32	0.44	5.20	1.62	4000	23.0
<b>MCS19J14-</b>	92	105	199	0.65	0.88	12.8	3.31	4000	30.0
<b>MCS19J30-</b>	93	105	99.5	0.16	0.22	3.20	1.65	4000	30.0
<b>MCS19P14-</b>	92	160	216	0.54	0.73	9.60	3.66	4000	40.0
<b>MCS19P30-</b>	93	160	108	0.14	0.18	2.40	1.83	4000	40.0

<sup>1)</sup> Without brake.

<sup>2)</sup> Mechanically permissible maximum speed.

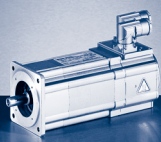

## MCS synchronous servo motors

### Rated data

#### Mains connection 3x 400 V

#### Motors with blower

	$n_N$	$M_0$	$M_{max}$	$M_N$	$P_N$	$I_0$	$I_N$	$I_{max}$	$U_{N,AC}$	$f_N$
	[r/min]	[Nm]	[Nm]	[Nm]	[kW]	[A]	[A]	[A]	[V]	[Hz]
MCS12D17-	1650	7.50	17.7	7.00	1.20	3.20	3.00	10.0	330	110
MCS12D35-	3525	7.50	17.7	6.00	2.20	6.40	5.60	20.0	300	235
MCS12H14-	1350	12.8	29.0	12.0	1.70	4.30	4.10	12.0	310	90
MCS12H34-	3375	12.8	29.0	10.5	3.70	8.50	7.50	24.0	320	225
MCS12L17-	1650	19.0	56.4	17.0	2.90	7.20	6.70	28.0	300	110
MCS12L39-	3900	19.0	56.4	14.0	5.70	14.4	11.7	57.0	295	260
MCS14D14-	1350	12.5	29.0	12.0	1.70	5.70	5.40	17.0	345	90
MCS14D30-	3000	12.5	29.0	10.5	3.30	11.4	9.70	33.0	325	200
MCS14H12-	1200	25.5	54.8	13.5	3.00	9.30	8.30	26.0	335	80
MCS14H28-	2775	25.5	54.8	20.5	6.00	18.4	15.0	52.0	325	185
MCS14L14-	1350	34.5	77.1	30.5	4.30	13.4	11.8	37.0	335	90
MCS14L30-	3000	34.5	77.1	25.5	8.00	26.7	20.8	75.0	310	200
MCS14P11-	1050	43.5	105	42.0	4.60	14.1	13.4	46.0	330	70
MCS14P26-	2625	43.5	105	33.0	9.10	28.3	21.9	92.0	325	175

  

	$\eta_{100\%}$	$J^1)$	$KE_{LL 150^\circ C}$	$R_{UV 20^\circ C}$	$R_{UV 150^\circ C}$	$L_N$	$Kt_{0 150^\circ C}$	$n_{max}^2)$	$m^1)$
	[%]	[kgcm <sup>2</sup> ]	[V / 1000 rp]	[ $\Omega$ ]	[ $\Omega$ ]	[mH]	[Nm/A]	[r/min]	[kg]
MCS12D17-	75	4.00	137	8.72	11.8	52.2	2.34	6000	8.50
MCS12D35-	82	4.00	68.6	2.18	2.94	13.0	1.17	6000	8.50
MCS12H14-	80	7.30	173	5.72	7.72	42.1	2.98	6000	11.6
MCS12H34-	86	7.30	86.5	1.39	1.88	10.5	1.51	6000	11.6
MCS12L17-	90	10.6	149	2.22	2.99	21.8	2.64	6000	14.7
MCS12L39-	94	10.6	74.6	0.55	0.75	5.50	1.32	6000	14.7
MCS14D14-	84	8.10	129	4.00	5.40	49.8	2.19	6000	14.5
MCS14D30-	92	8.10	64.2	1.00	1.35	12.5	1.09	6000	14.5
MCS14H12-	87	14.2	153	1.94	2.61	34.1	2.75	6000	19.5
MCS14H28-	93	14.2	76.3	0.48	0.65	8.50	1.39	6000	19.5
MCS14L14-	88	23.4	152	1.21	1.64	22.0	2.57	6000	24.0
MCS14L30-	92	23.4	76.2	0.30	0.41	5.50	1.29	6000	24.0
MCS14P11-	86	34.7	179	1.10	1.49	23.9	3.08	6000	29.0
MCS14P26-	92	34.7	89.4	0.28	0.37	6.00	1.54	6000	29.0

<sup>1)</sup> Without brake.

<sup>2)</sup> Mechanically permissible maximum speed.



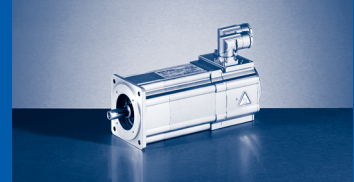

## Mains connection 3x 400 V

### Motors with blower

	$n_N$	$M_0$	$M_{max}$	$M_N$	$P_N$	$I_0$	$I_N$	$I_{max}$	$U_{N,AC}$	$f_N$
	[r/min]	[Nm]	[Nm]	[Nm]	[kW]	[A]	[A]	[A]	[V]	[Hz]
<b>MCS19F12-</b>	1200	41.5	86.0	38.0	4.80	12.2	11.3	31.0	320	80
<b>MCS19F29-</b>	2850	41.5	86.0	32.5	9.70	24.5	20.1	63.0	320	190
<b>MCS19J12-</b>	1200	70.5	129	62.5	7.90	20.3	18.3	45.0	320	80
<b>MCS19J29-</b>	2850	70.5	129	50.5	15.1	40.6	31.0	90.0	315	190
<b>MCS19P12-</b>	1200	86.0	190	72.0	9.00	22.4	21.3	60.0	310	80
<b>MCS19P29-</b>	2850	86.0	190	53.0	15.8	44.7	29.5	120	315	190

	$\eta_{100\%}$	$J^1$	$KE_{LL 150\text{ }^\circ\text{C}}$	$R_{UV 20\text{ }^\circ\text{C}}$	$R_{UV 150\text{ }^\circ\text{C}}$	$L_N$	$Kt_{0 150\text{ }^\circ\text{C}}$	$n_{max}^2$	$m^1$
	[%]	[kgcm <sup>2</sup> ]	[V /1000 rp]	[ $\Omega$ ]	[ $\Omega$ ]	[mH]	[Nm/A]	[r/min]	[kg]
<b>MCS19F12-</b>	90	65.0	195	1.30	1.75	20.8	3.40	4000	29.0
<b>MCS19F29-</b>	95	65.0	97.2	0.32	0.44	5.20	1.69	4000	29.0
<b>MCS19J12-</b>	89	105	199	0.65	0.88	12.8	3.47	4000	36.0
<b>MCS19J29-</b>	93	105	99.5	0.16	0.22	3.20	1.74	4000	36.0
<b>MCS19P12-</b>	90	160	216	0.54	0.73	9.60	3.84	4000	46.0
<b>MCS19P29-</b>	93	160	108	0.14	0.18	2.40	1.92	4000	46.0

<sup>1)</sup> Without brake.

<sup>2)</sup> Mechanically permissible maximum speed.

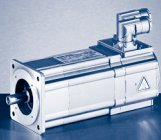

## MCS synchronous servo motors

### Rated data

#### Mains connection 3x 230 V

#### Motors without blower

	$n_N$	$M_0$	$M_{max}$	$M_N$	$P_N$	$I_0$	$I_N$	$I_{max}$	$U_{N,AC}$	$f_N$
	[r/min]	[Nm]	[Nm]	[Nm]	[kW]	[A]	[A]	[A]	[V]	[Hz]
MCS06C41L	4050	0.80	2.40	0.60	0.25	2.50	2.50	10.8	125	270
MCS06C60L	6000	0.80	2.40	0.50	0.31	4.30	4.00	18.5	85	400
MCS06F41L	4050	1.50	4.40	1.20	0.51	2.90	2.90	10.5	165	270
MCS06F60L	6000	1.50	4.40	0.90	0.57	3.80	3.40	16.5	125	400
MCS06I41L	4050	2.00	6.20	1.50	0.64	3.10	2.90	11.8	175	270
MCS06I60L	6000	2.00	6.20	1.20	0.75	4.20	3.60	16.0	150	400
MCS09D41L	4050	3.30	9.50	2.30	1.00	5.30	4.60	20.0	165	270
MCS09D60L	6000	3.30	9.50	1.80	1.10	10.3	7.00	39.0	110	400
MCS09F38L	3750	4.20	15.0	3.10	1.20	6.00	5.00	30.0	160	250
MCS09F60L	6000	4.20	15.0	2.40	1.50	10.5	7.90	53.0	125	400
MCS09H41L	4050	5.50	20.0	3.80	1.60	8.50	6.80	40.0	160	270
MCS09H60L	6000	5.50	20.0	3.00	1.90	12.0	8.00	57.0	145	400
MCS09L41L	4050	7.50	32.0	4.50	1.90	12.4	8.40	64.0	145	270

	$\eta_{100\%}$	$J^1$	$KE_{LL 150^\circ C}$	$R_{UV 20^\circ C}$	$R_{UV 150^\circ C}$	$L_N$	$Kt_{0 150^\circ C}$	$n_{max}^2$	$m^1$
	[%]	[kgcm <sup>2</sup> ]	[V / 1000 rp]	[ $\Omega$ ]	[ $\Omega$ ]	[mH]	[Nm/A]	[r/min]	[kg]
MCS06C41L	65	0.14	21.5	6.00	8.00	12.8	0.33	8000	1.80
MCS06C60L	70	0.14	12.5	2.20	2.90	4.30	0.19	8000	1.80
MCS06F41L	81	0.22	34.5	5.50	7.40	15.9	0.62	8000	2.20
MCS06F60L	82	0.22	22.2	2.30	3.00	6.90	0.40	8000	2.20
MCS06I41L	81	0.30	38.0	4.70	6.20	15.1	0.64	8000	2.90
MCS06I60L	84	0.30	28.5	2.50	3.40	9.30	0.48	8000	2.90
MCS09D41L	87	1.10	35.6	1.80	2.40	6.30	0.62	7000	4.30
MCS09D60L	87	1.10	18.3	0.45	1.20	1.70	0.32	7000	4.30
MCS09F38L	90	1.50	39.9	1.30	1.80	6.20	0.70	7000	5.20
MCS09F60L	91	1.50	22.8	0.42	0.56	2.00	0.40	7000	5.20
MCS09H41L	91	1.90	37.8	0.80	1.10	4.00	0.65	7000	6.10
MCS09H60L	91	1.90	26.6	0.36	0.48	2.00	0.46	7000	6.10
MCS09L41L	91	2.80	35.9	0.44	0.59	2.50	0.60	7000	7.90

<sup>1)</sup> Without brake.

<sup>2)</sup> Mechanically permissible maximum speed.

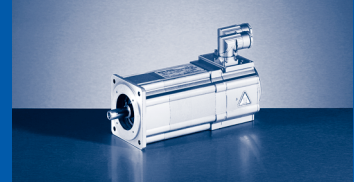

## Mains connection 3x 230 V

### Motors without blower

	$n_N$	$M_0$	$M_{max}$	$M_N$	$P_N$	$I_0$	$I_N$	$I_{max}$	$U_{N,AC}$	$f_N$
	[r/min]	[Nm]	[Nm]	[Nm]	[kW]	[A]	[A]	[A]	[V]	[Hz]
<b>MCS12D20L</b>	1950	6.40	18.0	5.50	1.10	5.50	5.20	20.0	175	130
<b>MCS12D41L</b>	4050	6.40	18.0	4.30	1.80	10.7	8.80	40.0	155	270
<b>MCS12H15L</b>	1500	11.4	29.0	10.0	1.60	8.20	7.80	24.0	158	100
<b>MCS12H30L</b>	3000	11.4	29.0	8.00	2.50	13.5	10.5	39.0	165	200
<b>MCS12L20L</b>	1950	15.0	56.0	13.5	2.80	12.4	11.8	57.0	165	130

	$\eta_{100\%}$	$J^1$	$KE_{LL 150^\circ C}$	$R_{UV 20^\circ C}$	$R_{UV 150^\circ C}$	$L_N$	$Kt_{0 150^\circ C}$	$n_{max}^2$	$m^1$
	[%]	[kgcm <sup>2</sup> ]	[V / 1000 rp]	[ $\Omega$ ]	[ $\Omega$ ]	[mH]	[Nm/A]	[r/min]	[kg]
<b>MCS12D20L</b>	79	4.00	68.6	2.20	2.90	13.0	1.17	6000	6.40
<b>MCS12D41L</b>	84	4.00	35.0	0.55	0.75	3.40	0.60	6000	6.40
<b>MCS12H15L</b>	82	7.30	86.5	1.43	1.93	10.5	1.40	6000	9.50
<b>MCS12H30L</b>	87	7.30	53.0	0.50	0.67	4.00	0.86	6000	9.50
<b>MCS12L20L</b>	90	10.6	76.9	0.55	0.75	5.50	1.21	6000	12.6

<sup>1)</sup> Without brake.

<sup>2)</sup> Mechanically permissible maximum speed.

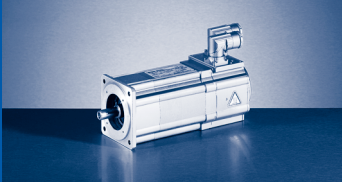

# MCS synchronous servo motors

## Rated data

### Permissible radial and axial forces

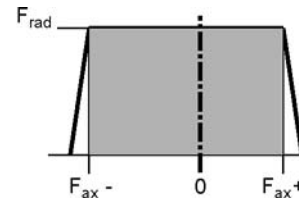
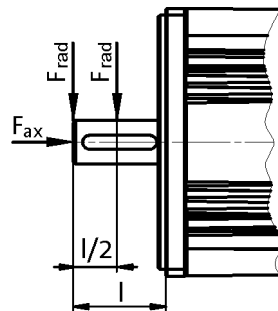

#### Application of force at l/2

	Bearing service life $L_{10}$														
	5000 h			10000 h			20000 h			30000 h			50000 h		
	$F_{rad}$	$F_{ax,-}$	$F_{ax,+}$	$F_{rad}$	$F_{ax,-}$	$F_{ax,+}$	$F_{rad}$	$F_{ax,-}$	$F_{ax,+}$	$F_{rad}$	$F_{ax,-}$	$F_{ax,+}$	$F_{rad}$	$F_{ax,-}$	$F_{ax,+}$
	[N]	[N]	[N]	[N]	[N]	[N]	[N]	[N]	[N]	[N]	[N]	[N]	[N]	[N]	[N]
<b>MCS06</b>	740	-260	140	590	-210	80	470	-170	40	410	-150	30	340	-140	10
<b>MCS09</b>	1040	-700	470	830	-550	310	660	-440	200	580	-380	150	490	-330	90
<b>MCS12</b>	1030	-880	560	820	-690	370	650	-550	230	570	-490	160	480	-420	100
<b>MCS14</b>	1830	-1150	720	1450	-900	470	1150	-720	290	1010	-640	200	850	-550	120
<b>MCS19</b>	3840	-1550	950	3050	-1210	620	2430	-960	360	2120	-840	250	1790	-730	130

#### Application of force at l

	Bearing service life $L_{10}$														
	5000 h			10000 h			20000 h			30000 h			50000 h		
	$F_{rad}$	$F_{ax,-}$	$F_{ax,+}$	$F_{rad}$	$F_{ax,-}$	$F_{ax,+}$	$F_{rad}$	$F_{ax,-}$	$F_{ax,+}$	$F_{rad}$	$F_{ax,-}$	$F_{ax,+}$	$F_{rad}$	$F_{ax,-}$	$F_{ax,+}$
	[N]	[N]	[N]	[N]	[N]	[N]	[N]	[N]	[N]	[N]	[N]	[N]	[N]	[N]	[N]
<b>MCS06</b>	630	-210	90	500	-170	50	400	-140	20	350	-130	0	290	-120	-10
<b>MCS09</b>	900	-630	400	710	-500	260	570	-400	160	500	-350	120	420	-300	70
<b>MCS12</b>	890	-820	490		-640	320	560	-520	190	490	-460	130		-400	
<b>MCS14</b>	1590	-1040	610	1260	-820	390	1000	-660	230	880	-580	150	740	-510	
<b>MCS19</b>	3330	-1320	730	2650	-1040	450	2100	-830	240	1840	-740	140	1550	-640	40

- ▶ The values for the bearing service life  $L_{10}$  refer to an average speed of 4000 r/min. Depending on the ambient temperatures, the service life of the bearings is also reduced by the grease lifetime.

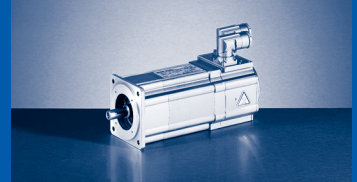

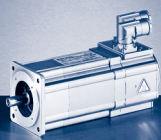

# MCS synchronous servo motors

## 9400 Servo Drives selection tables

### Mains connection 3 x 400 V and switching frequency 4 kHz

#### Motors without blower

					E94A□□	E0024	E0034	E0044	E0074	E0094	E0134	E0174	E0244	E0324	E0474	E0594
					$I_N$	1.9	3.1	5.0	8.8	11.7	16.3	20.6	29.4	38.4	47.0	59.0
					$I_{0,max}$	6.0	10.0	16.0	21.0	28.0	39.0	49.5	58.8	76.8	94.0	118.0
MCS	$M_N$	$n_N$	$I_N$	$P_N$	$I_{max}$	6.0	10.0	16.0	21.0	28.0	39.0	49.5	58.8	76.8	94.0	118.0
06C41-	0.6	4050	1.3	0.25	$M_0$	0.8										
					$M_N$	0.6										
					$M_{0,max}$	2.4										
					$M_{max}$	2.4										
					$\eta_{eto}$	-										
06C60-	0.5	6000	2.4	0.31	$M_0$	0.6	0.8									
					$M_N$	0.4	0.5									
					$M_{0,max}$	1.5	2.3									
					$M_{max}$	1.5	2.3									
					$\eta_{eto}$	-	-									
06F41-	1.2	4050	1.5	0.51	$M_0$	1.5										
					$M_N$	1.2										
					$M_{0,max}$	4.4										
					$M_{max}$	4.4										
					$\eta_{eto}$	-										
06F60-	0.9	6000	2.5	0.57	$M_0$	1.0	1.5									
					$M_N$	0.7	0.9									
					$M_{0,max}$	3.0	4.3									
					$M_{max}$	3.0	4.3									
					$\eta_{eto}$	-	-									
06I41-	1.5	4050	1.6	0.64	$M_0$	2.0										
					$M_N$	1.5										
					$M_{0,max}$	6.2										
					$M_{max}$	6.2										
					$\eta_{eto}$	-										
06I60-	1.2	6000	2.9	0.75	$M_0$	1.1	1.8	2.0								
					$M_N$	0.8	1.2	1.2								
					$M_{0,max}$	3.3	5.5	6.2								
					$M_{max}$	3.3	5.5	6.2								
					$\eta_{eto}$	-	-	-								
09D41-	2.3	4050	2.3	1.00	$M_0$	2.4	3.3									
					$M_N$	1.9	2.3									
					$M_{0,max}$	6.3	9.5									
					$M_{max}$	6.3	9.5									
					$\eta_{eto}$	-	-									
09D60-	1.8	6000	3.8	1.10	$M_0$			3.1	3.3							
					$M_N$			1.8	1.8							
					$M_{0,max}$			8.0	9.5							
					$M_{max}$			8.0	9.5							
					$\eta_{eto}$			-	-							
09F38-	3.1	3750	2.5	1.20	$M_0$		4.2	4.2								
					$M_N$		3.1	3.1								
					$M_{0,max}$		11.6	14.9								
					$M_{max}$		11.6	14.9								
					$\eta_{eto}$		-	-								
09F60-	2.4	6000	4.5	1.50	$M_0$			3.5	4.2	4.2	4.2					
					$M_N$			2.4	2.4	2.4	2.4					
					$M_{0,max}$			9.8	12.0	14.4	14.9					
					$M_{max}$			9.8	12.0	14.4	14.9					
					$\eta_{eto}$			-	-	-	-					

► I... [A], M... [Nm], n... [r/min], P... [kW]

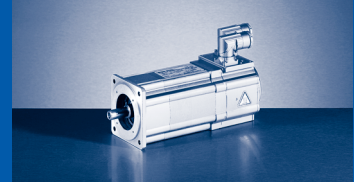

### Mains connection 3 x 400 V and switching frequency 4 kHz

#### Motors without blower

					E94A□□	E0024	E0034	E0044	E0074	E0094	E0134	E0174	E0244	E0324	E0474	E0594
					$I_N$	1.9	3.1	5.0	8.8	11.7	16.3	20.6	29.4	38.4	47.0	59.0
					$I_{0,max}$	6.0	10.0	16.0	21.0	28.0	39.0	49.5	58.8	76.8	94.0	118.0
MCS	$M_N$	$n_N$	$I_N$	$P_N$	$I_{max}$	6.0	10.0	16.0	21.0	28.0	39.0	49.5	58.8	76.8	94.0	118.0
09H41-	3.8	4050	3.4	1.60	$M_0$		4.0	5.5	5.5							
					$M_N$		3.5	3.8	3.8							
					$M_{0,max}$		12.0	17.5	20.4							
					$M_{max}$		12.0	17.5	20.4							
					$\eta_{eto}$		-	-	-							
09H60-	3.0	6000	6.0	1.90	$M_0$				5.5	5.5	5.5	5.5				
					$M_N$				3.0	3.0	3.0	3.0				
					$M_{0,max}$				12.5	15.8	20.1	20.4				
					$M_{max}$				12.5	15.8	20.1	20.4				
					$\eta_{eto}$				-	-	-	-				
09L41-	4.5	4050	4.2	1.90	$M_0$			6.0	7.5	7.5						
					$M_N$			4.5	4.5	4.5						
					$M_{0,max}$			17.4	22.2	28.5						
					$M_{max}$			17.4	22.2	28.5						
					$\eta_{eto}$			-	-	-						
09L51-	3.6	5100	6.9	1.90	$M_0$				5.3	7.0	7.5	7.5	7.5			
					$M_N$				3.6	3.6	3.6	3.6	3.6			
					$M_{0,max}$				11.9	15.5	20.9	25.8	29.7			
					$M_{max}$				11.9	15.5	20.9	25.8	29.7			
					$\eta_{eto}$				-	-	-	-	-			
12D20-	5.5	1950	2.6	1.10	$M_0$	4.4	6.4									
					$M_N$	4.0	5.5									
					$M_{0,max}$	11.8	17.7									
					$M_{max}$	11.8	17.7									
					$\eta_{eto}$	-	-									
12D41-	4.3	4050	4.5	1.80	$M_0$			5.9	6.4							
					$M_N$			4.3	4.3							
					$M_{0,max}$			14.7	17.7							
					$M_{max}$			14.7	17.7							
					$\eta_{eto}$			-	-							
12H15-	10.0	1500	3.8	1.60	$M_0$		8.7	11.4								
					$M_N$		8.2	10.0								
					$M_{0,max}$		24.6	29.0								
					$M_{max}$		24.6	29.0								
					$\eta_{eto}$		-	-								
12H35-	7.5	3525	5.7	2.80	$M_0$			7.0	11.4	11.4	11.4					
					$M_N$			6.6	7.5	7.5	7.5					
					$M_{0,max}$			20.1	25.8	29.0	29.0					
					$M_{max}$			20.1	25.8	29.0	29.0					
					$\eta_{eto}$			-	-	-	-					
12L20-	13.5	1950	5.9	2.80	$M_0$			12.1	15.0	15.0	15.0					
					$M_N$			11.4	13.5	13.5	13.5					
					$M_{0,max}$			35.5	44.6	55.7	56.4					
					$M_{max}$			35.5	44.6	55.7	56.4					
					$\eta_{eto}$			-	-	-	-					
12L41-	11.0	4050	10.2	4.70	$M_0$				10.6	14.0	15.0	15.0	15.0			
					$M_N$				9.5	11.0	11.0	11.0				
					$M_{0,max}$				24.4	31.6	41.9	50.8	56.4			
					$M_{max}$				24.4	31.6	41.9	50.8	56.4			
					$\eta_{eto}$				-	-	-	-	-			

►  $I...$  [A],  $M...$  [Nm],  $n...$  [r/min],  $P...$  [kW]

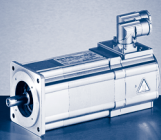

# MCS synchronous servo motors

## 9400 Servo Drives selection tables

### Mains connection 3 x 400 V and switching frequency 4 kHz

#### Motors without blower

					E94A□□	E0024	E0034	E0044	E0074	E0094	E0134	E0174	E0244	E0324	E0474	E0594
					$I_N$	1.9	3.1	5.0	8.8	11.7	16.3	20.6	29.4	38.4	47.0	59.0
					$I_{0,max}$	6.0	10.0	16.0	21.0	28.0	39.0	49.5	58.8	76.8	94.0	118.0
MCS	$M_N$	$n_N$	$I_N$	$P_N$	$I_{max}$	6.0	10.0	16.0	21.0	28.0	39.0	49.5	58.8	76.8	94.0	118.0
14D15-	9.2	1500	4.5	1.45	$M_0$			11.0	11.0							
					$M_N$			9.2	9.2							
					$M_{0,max}$			28.3	29.0							
					$M_{max}$			28.3	29.0							
					$\eta_{eto}$			-	-							
14D36-	7.5	3600	7.5	2.80	$M_0$				9.6	11.0	11.0					
					$M_N$				7.5	7.5	7.5					
					$M_{0,max}$				20.2	25.6	29.0					
					$M_{max}$				20.2	25.6	29.0					
					$\eta_{eto}$				-	-	-					
14H15-	16.0	1500	6.6	2.50	$M_0$			12.4	21.0	21.0	21.0					
					$M_N$			12.1	16.0	16.0	16.0					
					$M_{0,max}$			37.1	46.6	54.8	54.8					
					$M_{max}$			37.1	46.6	54.8	54.8					
					$\eta_{eto}$			-	-	-	-					
14H32-	14.0	3225	11.9	4.70	$M_0$					14.4	20.3	21.0	21.0			
					$M_N$					13.6	14.0	14.0	14.0			
					$M_{0,max}$					33.0	43.9	53.2	54.8			
					$M_{max}$					33.0	43.9	53.2	54.8			
					$\eta_{eto}$					-	-	-	-			
14L15-	23.0	1500	9.7	3.60	$M_0$				20.5	27.1	28.0					
					$M_N$				20.9	23.0	23.0					
					$M_{0,max}$				48.0	61.4	77.1					
					$M_{max}$				48.0	61.4	77.1					
					$\eta_{eto}$				-	-	-					
14L32-	17.2	3225	15.0	5.80	$M_0$						19.0	24.0	28.0	28.0	28.0	
					$M_N$					17.2	17.2	17.2	17.2	17.2	17.2	
					$M_{0,max}$					45.0	55.3	63.9	77.1	77.1		
					$M_{max}$					45.0	55.3	63.9	77.1	77.1		
					$\eta_{eto}$					-	-	-	-	-		
14P14-	30.0	1350	10.8	4.20	$M_0$				26.7	35.2	37.0	37.0				
					$M_N$				24.4	30.0	30.0	30.0				
					$M_{0,max}$				56.1	71.7	93.3	105.1				
					$M_{max}$				56.1	71.7	93.3	105.1				
					$\eta_{eto}$				-	-	-	-				
14P32-	21.0	3225	15.6	7.10	$M_0$						24.8	31.4	37.0	37.0	37.0	
					$M_N$					21.0	21.0	21.0	21.0	21.0	21.0	
					$M_{0,max}$					52.5	64.6	74.7	92.2	105.1		
					$M_{max}$					52.5	64.6	74.7	92.2	105.1		
					$\eta_{eto}$					-	-	-	-	-		
19F14-	27.0	1425	8.6	4.00	$M_0$				28.4	32.0	32.0					
					$M_N$				27.0	27.0	27.0					
					$M_{0,max}$				62.1	78.9	86.0					
					$M_{max}$				62.1	78.9	86.0					
					$\eta_{eto}$				-	-	-					
19F30-	21.0	3000	14.0	6.60	$M_0$						26.3	32.0	32.0	32.0		
					$M_N$					21.0	21.0	21.0	21.0	21.0		
					$M_{0,max}$					56.6	70.2	81.6	86.0			
					$M_{max}$					56.6	70.2	81.6	86.0			
					$\eta_{eto}$					-	-	-	-	-		

►  $I...$  [A],  $M...$  [Nm],  $n...$  [r/min],  $P...$  [kW]



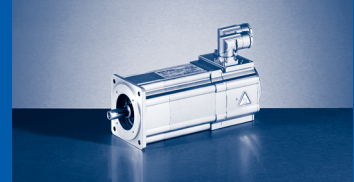

### Mains connection 3 x 400 V and switching frequency 4 kHz

#### Motors without blower

					E94A□□	E0024	E0034	E0044	E0074	E0094	E0134	E0174	E0244	E0324	E0474	E0594
					$I_N$	1.9	3.1	5.0	8.8	11.7	16.3	20.6	29.4	38.4	47.0	59.0
					$I_{0,max}$	6.0	10.0	16.0	21.0	28.0	39.0	49.5	58.8	76.8	94.0	118.0
MCS	$M_N$	$n_N$	$I_N$	$P_N$	$I_{max}$	6.0	10.0	16.0	21.0	28.0	39.0	49.5	58.8	76.8	94.0	118.0
19J14-	40.0	1425	12.3	6.00	$M_0$					38.9	51.0	51.0				
					$M_N$					37.7	40.0	40.0				
					$M_{0,max}$					85.0	114.4	129.0				
					$M_{max}$					85.0	114.4	129.0				
					$n_{eto}$					-	-	-				
19J30-	29.0	3000	18.5	9.10	$M_0$						27.3	34.4	49.2	51.0	51.0	
					$M_N$						25.6	29.0	29.0	29.0	29.0	
					$M_{0,max}$						60.8	75.9	88.9	112.9	129.0	
					$M_{max}$						60.8	75.9	88.9	112.9	129.0	
					$n_{eto}$						-	-	-	-	-	
19P14-	51.0	1350	14.3	7.20	$M_0$						59.6	64.0	64.0	64.0		
					$M_N$						51.0	51.0	51.0	51.0		
					$M_{0,max}$						128.4	159.9	186.6	190.0		
					$M_{max}$						128.4	159.9	186.6	190.0		
					$n_{eto}$						-	-	-	-		
19P30-	32.0	3000	19.0	10.00	$M_0$						29.9	37.8	53.9	64.0	64.0	64.0
					$M_N$						27.5	32.0	32.0	32.0	32.0	32.0
					$M_{0,max}$						65.7	83.6	98.5	126.6	152.5	187.2
					$M_{max}$						65.7	83.6	98.5	126.6	152.5	187.2
					$n_{eto}$						-	-	-	-	-	

►  $I...$  [A],  $M...$  [Nm],  $n...$  [r/min],  $P...$  [kW]

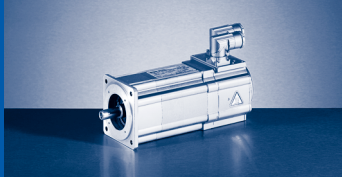

# MCS synchronous servo motors

## 9400 Servo Drives selection tables

### Mains connection 3 x 400 V and switching frequency 4 kHz

#### Motors with blower

					E94A□□	E0024	E0034	E0044	E0074	E0094	E0134	E0174	E0244	E0324	E0474	E0594
					$I_N$	1.9	3.1	5.0	8.8	11.7	16.3	20.6	29.4	38.4	47.0	59.0
					$I_{0,max}$	6.0	10.0	16.0	21.0	28.0	39.0	49.5	58.8	76.8	94.0	118.0
MCS	$M_N$	$n_N$	$I_N$	$P_N$	$I_{max}$	6.0	10.0	16.0	21.0	28.0	39.0	49.5	58.8	76.8	94.0	118.0
12D17-	7.0	1650	3.0	1.20	$M_0$	4.4	7.3									
					$M_N$	4.0	7.0									
					$M_{0,max}$	11.8	17.7									
					$M_{max}$	11.8	17.7									
					$\eta_{eto}$	-	-									
12D35-	6.0	3525	5.6	2.20	$M_0$			5.9	7.5							
					$M_N$			5.4	6.0							
					$M_{0,max}$			14.7	17.7							
					$M_{max}$			14.7	17.7							
					$\eta_{eto}$			-	-							
12H14-	12.0	1350	4.1	1.70	$M_0$		8.7	12.8								
					$M_N$		8.2	12.0								
					$M_{0,max}$		24.6	29.0								
					$M_{max}$		24.6	29.0								
					$\eta_{eto}$		-	-								
12H34-	10.5	3375	7.5	3.70	$M_0$			7.0	12.8	12.8	12.8					
					$M_N$			6.6	10.5	10.5	10.5					
					$M_{0,max}$			20.1	25.8	29.0	29.0					
					$M_{max}$			20.1	25.8	29.0	29.0					
					$\eta_{eto}$			-	-	-	-					
12L17-	17.0	1650	6.7	2.90	$M_0$			12.1	19.0	19.0	19.0					
					$M_N$			11.4	17.0	17.0	17.0					
					$M_{0,max}$			35.5	44.6	55.7	56.4					
					$M_{max}$			35.5	44.6	55.7	56.4					
					$\eta_{eto}$			-	-	-	-					
12L39-	14.0	3900	11.7	5.70	$M_0$				10.6	15.3	19.0	19.0	19.0			
					$M_N$				9.5	13.9	14.0	14.0	14.0			
					$M_{0,max}$				24.4	31.6	41.9	50.8	56.4			
					$M_{max}$				24.4	31.6	41.9	50.8	56.4			
					$\eta_{eto}$				-	-	-	-	-			
14D14-	12.0	1350	5.4	1.70	$M_0$			11.0	12.5							
					$M_N$			11.0	12.0							
					$M_{0,max}$			28.3	29.0							
					$M_{max}$			28.3	29.0							
					$\eta_{eto}$			-	-							
14D30-	10.5	3000	9.7	3.30	$M_0$				9.6	12.5	12.5					
					$M_N$				9.5	10.5	10.5					
					$M_{0,max}$				20.2	25.6	29.0					
					$M_{max}$				20.2	25.6	29.0					
					$\eta_{eto}$				-	-	-					
14H12-	23.5	1200	8.3	3.00	$M_0$			12.4	24.1	25.5	25.5					
					$M_N$			12.1	23.5	23.5	23.5					
					$M_{0,max}$			37.1	46.6	54.8	54.8					
					$M_{max}$			37.1	46.6	54.8	54.8					
					$\eta_{eto}$			-	-	-	-					
14H28-	20.5	2775	15.0	6.00	$M_0$					16.1	20.5	25.5	25.5			
					$M_N$					15.9	20.5	20.5	20.5			
					$M_{0,max}$					33.0	43.9	53.2	54.8			
					$M_{max}$					33.0	43.9	53.2	54.8			
					$\eta_{eto}$					-	-	-	-			

►  $I...$  [A],  $M...$  [Nm],  $n...$  [r/min],  $P...$  [kW]

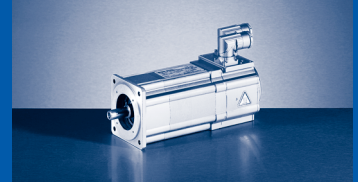

### Mains connection 3 x 400 V and switching frequency 4 kHz

#### Motors with blower

					E94A□□	E0024	E0034	E0044	E0074	E0094	E0134	E0174	E0244	E0324	E0474	E0594	
					I <sub>N</sub>	1.9	3.1	5.0	8.8	11.7	16.3	20.6	29.4	38.4	47.0	59.0	
					I <sub>0,max</sub>	6.0	10.0	16.0	21.0	28.0	39.0	49.5	58.8	76.8	94.0	118.0	
MCS	M <sub>N</sub>	n <sub>N</sub>	I <sub>N</sub>	P <sub>N</sub>	I <sub>max</sub>	6.0	10.0	16.0	21.0	28.0	39.0	49.5	58.8	76.8	94.0	118.0	
14L14-	30.5	1350	11.8	4.30	M <sub>0</sub>				20.5	30.0	34.5						
					M <sub>N</sub>				20.5	30.0	30.5						
					M <sub>0,max</sub>				48.0	61.4	77.1						
					M <sub>max</sub>				48.0	61.4	77.1						
					n <sub>eto</sub>				-	-	-						
14L30-	25.5	3000	20.8	8.00	M <sub>0</sub>						21.0	26.6	34.5	34.5	34.5		
					M <sub>N</sub>						20.0	25.3	25.5	25.5	25.5		
					M <sub>0,max</sub>						45.0	55.3	63.9	77.1	77.1		
					M <sub>max</sub>						45.0	55.3	63.9	77.1	77.1		
					n <sub>eto</sub>						-	-	-	-	-		
14P11-	42.0	1050	13.4	4.60	M <sub>0</sub>				26.7	36.4	43.5	43.5					
					M <sub>N</sub>				24.4	36.4	42.0	42.0					
					M <sub>0,max</sub>				56.1	71.7	93.3	105.1					
					M <sub>max</sub>				56.1	71.7	93.3	105.1					
					n <sub>eto</sub>				-	-	-	-					
14P26-	33.0	2625	21.9	9.10	M <sub>0</sub>						24.8	31.4	43.5	43.5	43.5		
					M <sub>N</sub>						24.6	31.0	33.0	33.0	33.0		
					M <sub>0,max</sub>						52.5	64.6	74.7	92.2	105.1		
					M <sub>max</sub>						52.5	64.6	74.7	92.2	105.1		
					n <sub>eto</sub>						-	-	-	-	-		
19F12-	38.0	1200	11.3	4.80	M <sub>0</sub>				29.9	39.5	41.5						
					M <sub>N</sub>				29.3	38.0	38.0						
					M <sub>0,max</sub>				62.1	78.9	86.0						
					M <sub>max</sub>				62.1	78.9	86.0						
					n <sub>eto</sub>				-	-	-						
19F29-	32.5	2850	20.1	9.70	M <sub>0</sub>						26.3	34.9	41.5	41.5			
					M <sub>N</sub>						26.0	32.5	32.5	32.5			
					M <sub>0,max</sub>						56.6	70.2	81.6	86.0			
					M <sub>max</sub>						56.6	70.2	81.6	86.0			
					n <sub>eto</sub>						-	-	-	-			
19J12-	62.5	1200	18.3	7.90	M <sub>0</sub>						56.6	70.5					
					M <sub>N</sub>						55.7	62.5					
					M <sub>0,max</sub>						114.4	129.0					
					M <sub>max</sub>						114.4	129.0					
					n <sub>eto</sub>						-	-					
19J29-	50.5	2850	31.0	15.10	M <sub>0</sub>								49.2	66.7	70.5		
					M <sub>N</sub>									47.9	50.5	50.5	
					M <sub>0,max</sub>									88.9	112.9	129.0	
					M <sub>max</sub>									88.9	112.9	129.0	
					n <sub>eto</sub>									-	-	-	
19P12-	72.0	1200	21.3	9.00	M <sub>0</sub>							79.1	86.0	86.0			
					M <sub>N</sub>								69.6	72.0	72.0		
					M <sub>0,max</sub>								159.9	186.6	190.0		
					M <sub>max</sub>								159.9	186.6	190.0		
					n <sub>eto</sub>								-	-	-		
19P29-	53.0	2850	29.5	15.80	M <sub>0</sub>								56.5	73.9	86.0	86.0	
					M <sub>N</sub>								52.8	53.0	53.0	53.0	
					M <sub>0,max</sub>								98.5	126.6	152.5	187.2	
					M <sub>max</sub>								98.5	126.6	152.5	187.2	
					n <sub>eto</sub>								-	-	-	-	

► I... [A], M... [Nm], n... [r/min], P... [kW]



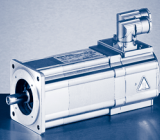

# MCS synchronous servo motors

## 9400 Servo Drives selection tables

### Mains connection 3 x 230 V and switching frequency 4 kHz

#### Motors without blower

					E94A□□	E0024	E0034	E0044	E0074	E0094	E0134	E0174	E0244	E0324
					$I_N$	1.9	3.1	5.0	8.8	11.7	16.3	20.6	29.4	38.4
					$I_{0,max}$	6.0	10.0	16.0	21.0	28.0	39.0	49.5	58.8	76.8
MCS	$M_N$	$n_N$	$I_N$	$P_N$	$I_{max}$	6.0	10.0	16.0	21.0	28.0	39.0	49.5	58.8	76.8
06C41L	0.6	4050	2.6	0.25	$M_0$	0.6	0.8							
					$M_N$	0.5	0.6							
					$M_{0,max}$	1.5	2.3							
					$M_{max}$	1.5	2.3							
					$\eta_{eto}$	-	-							
06C60L	0.5	6000	4.0	0.31	$M_0$		0.6	0.8	0.8					
					$M_N$		0.4	0.5	0.5					
					$M_{0,max}$		1.5	2.2	2.4					
					$M_{max}$		1.5	2.2	2.4					
					$\eta_{eto}$		-	-	-					
06F41L	1.2	4050	2.9	0.51	$M_0$	1.0	1.5	1.5						
					$M_N$	0.8	1.2	1.2						
					$M_{0,max}$	2.7	4.2	4.4						
					$M_{max}$	2.7	4.2	4.4						
					$\eta_{eto}$	-	-	-						
06F60L	0.9	6000	3.8	0.57	$M_0$		1.2	1.5	1.5					
					$M_N$		0.8	0.9	0.9					
					$M_{0,max}$		3.1	4.3	4.4					
					$M_{max}$		3.1	4.3	4.4					
					$\eta_{eto}$		-	-	-					
06I41L	1.5	4050	3.2	0.64	$M_0$		2.0	2.0						
					$M_N$		1.5	1.5						
					$M_{0,max}$		5.4	6.2						
					$M_{max}$		5.4	6.2						
					$\eta_{eto}$		-	-						
06I60L	1.2	6000	3.8	0.75	$M_0$		1.5	2.0						
					$M_N$		1.0	1.2						
					$M_{0,max}$		4.4	6.2						
					$M_{max}$		4.4	6.2						
					$\eta_{eto}$		-	-						
09D41L	2.3	4050	4.6	1.00	$M_0$			3.1	3.3					
					$M_N$			2.3	2.3					
					$M_{0,max}$			8.0	9.5					
					$M_{max}$			8.0	9.5					
					$\eta_{eto}$			-	-					
09D60L	1.8	6000	7.0	1.10	$M_0$				2.8	3.3	3.3			
					$M_N$				1.8	1.8	1.8			
					$M_{0,max}$				5.7	7.3	9.5			
					$M_{max}$				5.7	7.3	9.5			
					$\eta_{eto}$				-	-	-			
09F38L	3.1	3750	5.0	1.20	$M_0$			3.5	4.2	4.2	4.2			
					$M_N$			3.1	3.1	3.1	3.1			
					$M_{0,max}$			9.8	12.0	13.8	15.0			
					$M_{max}$			9.8	12.0	13.8	15.0			
					$\eta_{eto}$			-	-	-	-			
09F60L	2.4	6000	7.9	1.50	$M_0$				3.5	4.2	4.2	4.2	4.2	4.2
					$M_N$				2.4	2.4	2.4	2.4	2.4	2.4
					$M_{0,max}$				7.8	9.8	12.6	14.5	15.0	15.0
					$M_{max}$				7.8	9.8	12.6	14.5	15.0	15.0
					$\eta_{eto}$				-	-	-	-	-	-

► I... [A], M... [Nm], n... [r/min], P... [kW]

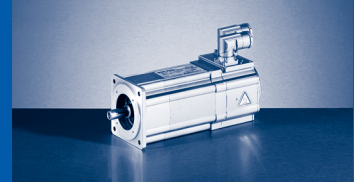

### Mains connection 3 x 230 V and switching frequency 4 kHz

#### Motors without blower

					E94A□□	E0024	E0034	E0044	E0074	E0094	E0134	E0174	E0244	E0324
					I <sub>N</sub>	1.9	3.1	5.0	8.8	11.7	16.3	20.6	29.4	38.4
					I <sub>0,max</sub>	6.0	10.0	16.0	21.0	28.0	39.0	49.5	58.8	76.8
MCS	M <sub>N</sub>	n <sub>N</sub>	I <sub>N</sub>	P <sub>N</sub>	I <sub>max</sub>	6.0	10.0	16.0	21.0	28.0	39.0	49.5	58.8	76.8
09H41L	3.8	4050	6.8	1.60	M <sub>0</sub>				5.5	5.3	5.5	5.5		
					M <sub>N</sub>				3.8	3.0	3.8	3.8		
					M <sub>0,max</sub>				12.4	11.8	19.7	20.0		
					M <sub>max</sub>				12.4	11.8	19.7	20.0		
					n <sub>eto</sub>				-	-	-	-		
09H60L	3.0	6000	8.0	1.90	M <sub>0</sub>				4.0	5.5	5.5	5.5	5.5	
					M <sub>N</sub>				3.0	3.8	3.0	3.0	3.0	
					M <sub>0,max</sub>				9.2	15.6	15.4	18.3	20.0	
					M <sub>max</sub>				9.2	15.6	15.4	18.3	20.0	
					n <sub>eto</sub>				-	-	-	-	-	
09L41L	4.5	4050	8.4	1.90	M <sub>0</sub>				5.3	7.0	7.5	7.5	7.5	7.5
					M <sub>N</sub>				4.5	4.5	4.5	4.5	4.5	4.5
					M <sub>0,max</sub>				11.9	15.5	20.9	25.8	29.7	31.9
					M <sub>max</sub>				11.9	15.5	20.9	25.8	29.7	31.9
					n <sub>eto</sub>				-	-	-	-	-	-
12D20L	5.5	1950	5.2	1.10	M <sub>0</sub>			5.9	6.4					
					M <sub>N</sub>				5.3	5.5				
					M <sub>0,max</sub>				14.9	17.7				
					M <sub>max</sub>				14.9	17.7				
					n <sub>eto</sub>				-	-				
12D41L	4.3	4050	8.8	1.80	M <sub>0</sub>				5.3	6.4	6.4	6.4		
					M <sub>N</sub>				4.3	4.3	4.3	4.3		
					M <sub>0,max</sub>				10.6	13.6	17.7	17.9		
					M <sub>max</sub>				10.6	13.6	17.7	17.9		
					n <sub>eto</sub>				-	-	-	-		
12H15L	10.0	1500	7.6	1.60	M <sub>0</sub>				11.4	11.4	10.0			
					M <sub>N</sub>				10.0	10.0	11.4			
					M <sub>0,max</sub>				25.8	29.0	29.0			
					M <sub>max</sub>				25.8	29.0	29.0			
					n <sub>eto</sub>				-	-	-			
12H30L	8.0	3000	10.5	2.50	M <sub>0</sub>				7.4	9.8	11.4			
					M <sub>N</sub>				6.7	8.0	8.0			
					M <sub>0,max</sub>				16.4	21.5	29.0			
					M <sub>max</sub>				16.4	21.5	29.0			
					n <sub>eto</sub>				-	-	-			
12L20L	13.5	1950	11.8	2.80	M <sub>0</sub>				10.6	14.0	15.0	15.0	15.0	
					M <sub>N</sub>				10.1	13.3	13.5	13.5	13.5	
					M <sub>0,max</sub>				24.4	31.5	41.8	50.5	56.0	
					M <sub>max</sub>				24.4	31.5	41.8	50.5	56.0	
					n <sub>eto</sub>				-	-	-	-	-	

► I... [A], M... [Nm], n... [r/min], P... [kW]

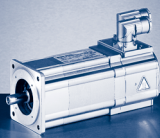

# MCS synchronous servo motors

## Selection tables for Inverter Drives 8400 TopLine

### Mains connection 3 x 400 V and switching frequency 8 kHz

#### Motors without blower

					E84AVTC	□3714	□5514	□7514	□1124	□1524	□2224	□3024	
					$I_N$	1.3	1.8	2.4	3.2	3.9	5.9	7.3	
					$I_{0,max}$	2.0	2.7	3.6	4.8	5.9	8.4	11.0	
MCS	$M_N$	$n_N$	$I_N$	$P_N$	$I_{max}$	2.6	3.6	4.8	6.4	7.8	11.8	14.6	
06C41-	0.6	4050	1.3	0.25	$M_0$	0.8	0.8	0.8	0.8	0.8			
					$M_N$	0.6	0.6	0.6	0.6	0.6			
					$M_{0,max}$	1.4	1.7	2.3	2.4	2.4			
					$M_{max}$	1.4	1.7	2.3	2.4	2.4			
					$\eta_{eto}$	-	-	-	-	-			
06C60-	0.5	6000	2.4	0.31	$M_0$			0.8	0.8	0.8	0.8	0.8	
					$M_N$			0.5	0.5	0.5	0.5	0.5	
					$M_{0,max}$			1.3	1.6	2.0	2.4	2.4	
					$M_{max}$			1.3	1.6	2.0	2.4	2.4	
					$\eta_{eto}$			-	-	-	-	-	
06F41-	1.2	4050	1.5	0.51	$M_0$	1.3	1.5	1.5	1.5	1.5			
					$M_N$	1.0	1.2	1.2	1.2	1.2			
					$M_{0,max}$	2.3	3.2	4.3	4.4	4.4			
					$M_{max}$	2.3	3.2	4.3	4.4	4.4			
					$\eta_{eto}$	-	-	-	-	-			
06F60-	0.9	6000	2.5	0.57	$M_0$			1.2	1.5	1.5	1.5	1.5	
					$M_N$			0.9	0.9	0.9	0.9	0.9	
					$M_{0,max}$			2.1	3.3	4.0	4.4	4.4	
					$M_{max}$			2.1	3.3	4.0	4.4	4.4	
					$\eta_{eto}$			-	-	-	-	-	
06I41-	1.5	4050	1.6	0.64	$M_0$	1.6	2.0	2.0	2.0	2.0			
					$M_N$	1.2	1.5	1.5	1.5	1.5			
					$M_{0,max}$	2.9	4.0	5.3	6.2	6.2			
					$M_{max}$	2.9	4.0	5.3	6.2	6.2			
					$\eta_{eto}$	-	-	-	-	-			
06I60-	1.2	6000	2.9	0.75	$M_0$				2.0	2.0	2.0	2.0	
					$M_N$				1.2	1.2	1.2	1.2	
					$M_{0,max}$				3.6	4.4	5.7	5.7	
					$M_{max}$				3.6	4.4	5.7	5.7	
					$\eta_{eto}$				-	-	-	-	
09D41-	2.3	4050	2.3	1.00	$M_0$		2.2	3.1	3.3	3.3	3.3	3.3	
					$M_N$		1.7	2.3	2.3	2.3	2.3	2.3	
					$M_{0,max}$		4.0	5.3	6.7	8.2	9.4	9.4	
					$M_{max}$		4.0	5.3	6.7	8.2	9.4	9.4	
					$\eta_{eto}$		-	-	-	-	-	-	
09D60-	1.8	6000	3.8	1.10	$M_0$				2.0	2.4	3.3	3.3	
					$M_N$				1.5	1.8	1.8	1.8	
					$M_{0,max}$				3.5	4.2	6.3	7.8	
					$M_{max}$				3.5	4.2	6.3	7.8	
					$\eta_{eto}$				-	-	-	-	
09F38-	3.1	3750	2.5	1.20	$M_0$			3.4	4.2	4.2	4.2	4.2	
					$M_N$			3.0	3.1	3.1	3.1	3.1	
					$M_{0,max}$			6.6	8.4	10.2	12.0	12.0	
					$M_{max}$			6.6	8.4	10.2	12.0	12.0	
					$\eta_{eto}$			-	-	-	-	-	
09F60-	2.4	6000	4.5	1.50	$M_0$						4.2	4.2	
					$M_N$							2.4	2.4
					$M_{0,max}$							7.8	9.6
					$M_{max}$							7.8	9.6
					$\eta_{eto}$							-	-

► I... [A], M... [Nm], n... [r/min], P... [kW]

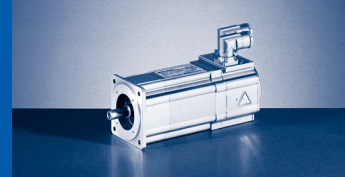

## Mains connection 3 x 400 V and switching frequency 8 kHz

### Motors without blower

□4024	□5524	□7524	□1134	□1534	□1834	□2234	□3034	E84AVTC					
9.5	13.0	16.5	23.5	32.0	39.0	47.0	61.0	$I_N$					
14.3	19.5	26.4	32.9	43.2	60.0	70.5	91.5	$I_{0,max}$					
19.0	26.0	33.0	47.0	64.0	78.0	94.0	122.0	$I_{max}$	$P_N$	$I_N$	$n_N$	$M_N$	MCS
								$M_0$ $M_N$ $M_{0,max}$ $M_{max}$ $n_{eto}$	0.25	1.3	4050	0.6	06C41-
								$M_0$ $M_N$ $M_{0,max}$ $M_{max}$ $n_{eto}$	0.31	2.4	6000	0.5	06C60-
								$M_0$ $M_N$ $M_{0,max}$ $M_{max}$ $n_{eto}$	0.51	1.5	4050	1.2	06F41-
								$M_0$ $M_N$ $M_{0,max}$ $M_{max}$ $n_{eto}$	0.57	2.5	6000	0.9	06F60-
								$M_0$ $M_N$ $M_{0,max}$ $M_{max}$ $n_{eto}$	0.64	1.6	4050	1.5	06I41-
								$M_0$ $M_N$ $M_{0,max}$ $M_{max}$ $n_{eto}$	0.75	2.9	6000	1.2	06I60-
								$M_0$ $M_N$ $M_{0,max}$ $M_{max}$ $n_{eto}$	1.00	2.3	4050	2.3	09D41-
3.3 1.8 9.1 9.1 -	3.3 1.8 9.3 9.3 -							$M_0$ $M_N$ $M_{0,max}$ $M_{max}$ $n_{eto}$	1.10	3.8	6000	1.8	09D60-
								$M_0$ $M_N$ $M_{0,max}$ $M_{max}$ $n_{eto}$	1.20	2.5	3750	3.1	09F38-
4.2 2.4 11.1 11.1 -	4.2 2.4 11.4 11.4 -							$M_0$ $M_N$ $M_{0,max}$ $M_{max}$ $n_{eto}$	1.50	4.5	6000	2.4	09F60-

►  $I...$  [A],  $M...$  [Nm],  $n...$  [r/min],  $P...$  [kW]

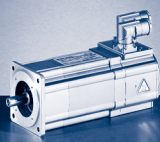

# MCS synchronous servo motors

Selection tables for Inverter Drives 8400 TopLine

## Mains connection 3 x 400 V and switching frequency 8 kHz

### Motors without blower

					E84AVTC	□3714	□5514	□7514	□1124	□1524	□2224	□3024
					$I_N$	1.3	1.8	2.4	3.2	3.9	5.9	7.3
					$I_{0,max}$	2.0	2.7	3.6	4.8	5.9	8.4	11.0
MCS	$M_N$	$n_N$	$I_N$	$P_N$	$I_{max}$	2.6	3.6	4.8	6.4	7.8	11.8	14.6
09H41-	3.8	4050	3.4	1.60	$M_0$				4.7	5.0	5.5	5.5
					$M_N$				3.6	3.8	3.8	3.8
					$M_{0,max}$				8.1	9.9	14.0	17.4
					$M_{max}$				8.1	9.9	14.0	17.4
					$\eta_{eto}$				-	-	-	-
09H60-	3.0	6000	6.0	1.90	$M_0$						4.4	4.5
					$M_N$						3.0	3.0
					$M_{0,max}$						7.5	9.3
					$M_{max}$						7.5	9.3
					$\eta_{eto}$						-	-
09L41-	4.5	4050	4.2	1.90	$M_0$				3.9	4.7	7.5	7.5
					$M_N$				3.4	4.2	4.5	4.5
					$M_{0,max}$				7.3	8.9	13.1	16.3
					$M_{max}$				7.3	8.9	13.1	16.3
					$\eta_{eto}$				-	-	-	-
09L51-	3.6	5100	6.9	1.90	$M_0$							4.2
					$M_N$							3.6
					$M_{0,max}$							8.3
					$M_{max}$							8.3
					$\eta_{eto}$							-
12D20-	5.5	1950	2.6	1.10	$M_0$			5.7	6.4	6.4	6.4	6.4
					$M_N$				5.1	5.5	5.5	5.5
					$M_{0,max}$				9.6	12.6	15.3	17.7
					$M_{max}$				9.6	12.6	15.3	17.7
					$\eta_{eto}$				-	-	-	-
12D41-	4.3	4050	4.5	1.80	$M_0$				3.8	4.6	6.4	6.4
					$M_N$				3.0	3.7	4.3	4.3
					$M_{0,max}$				6.4	7.8	11.4	14.0
					$M_{max}$				6.4	7.8	11.4	14.0
					$\eta_{eto}$				-	-	-	-
12H15-	10.0	1500	3.8	1.60	$M_0$				9.2	10.9	11.4	11.4
					$M_N$				8.4	10.0	10.0	10.0
					$M_{0,max}$				16.4	20.0	29.0	29.0
					$M_{max}$				16.4	20.0	29.0	29.0
					$\eta_{eto}$				-	-	-	-
12H35-	7.5	3525	5.7	2.80	$M_0$						9.8	9.8
					$M_N$						7.5	7.5
					$M_{0,max}$						15.2	18.8
					$M_{max}$						15.2	18.8
					$\eta_{eto}$						-	-
12L20-	13.5	1950	5.9	2.80	$M_0$						15.0	15.0
					$M_N$						13.5	13.5
					$M_{0,max}$						27.4	33.9
					$M_{max}$						27.4	33.9
					$\eta_{eto}$						-	-
12L41-	11.0	4050	10.2	4.70	$M_0$							
					$M_N$							
					$M_{0,max}$							
					$M_{max}$							
					$\eta_{eto}$							

►  $I...$  [A],  $M...$  [Nm],  $n...$  [r/min],  $P...$  [kW]



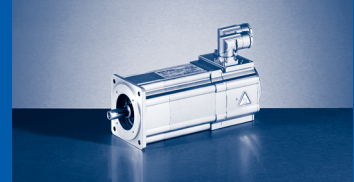

## Mains connection 3 x 400 V and switching frequency 8 kHz

### Motors without blower

□4024	□5524	□7524	□1134	□1534	□1834	□2234	□3034	E84AVTC					
9.5	13.0	16.5	23.5	32.0	39.0	47.0	61.0	$I_N$					
14.3	19.5	26.4	32.9	43.2	60.0	70.5	91.5	$I_{0,max}$					
19.0	26.0	33.0	47.0	64.0	78.0	94.0	122.0	$I_{max}$	$P_N$	$I_N$	$n_N$	$M_N$	MCS
5.5	5.5							$M_0$	1.60	3.4	4050	3.8	09H41-
3.8	3.8						$M_N$						
19.6	20.1						$M_{0,max}$						
19.6	20.1						$M_{max}$						
-	-						$\eta_{eto}$						
5.5	5.5							$M_0$	1.90	6.0	6000	3.0	09H60-
3.0	3.0						$M_N$						
11.4	11.7						$M_{0,max}$						
11.4	11.7						$M_{max}$						
-	-						$\eta_{eto}$						
7.5	7.5							$M_0$	1.90	4.2	4050	4.5	09L41-
4.5	4.5						$M_N$						
20.3	20.8						$M_{0,max}$						
20.3	20.8						$M_{max}$						
-	-						$\eta_{eto}$						
7.5	7.5	7.5	7.5					$M_0$	1.90	6.9	5100	3.6	09L51-
3.6	3.6	3.6	3.6				$M_N$						
10.8	19.1	19.1	19.1				$M_{0,max}$						
10.8	19.1	19.1	19.1				$M_{max}$						
-	-	-	-				$\eta_{eto}$						
								$M_0$	1.10	2.6	1950	5.5	12D20-
							$M_N$						
							$M_{0,max}$						
							$M_{max}$						
							$\eta_{eto}$						
6.4	6.4							$M_0$	1.80	4.5	4050	4.3	12D41-
4.3	4.3						$M_N$						
16.9	17.3						$M_{0,max}$						
16.9	17.3						$M_{max}$						
-	-						$\eta_{eto}$						
11.4	11.4							$M_0$	1.60	3.8	1500	10.0	12H15-
10.0	10.0						$M_N$						
28.3	29.0						$M_{0,max}$						
28.3	29.0						$M_{max}$						
-	-						$\eta_{eto}$						
11.4	11.4							$M_0$	2.80	5.7	3525	7.5	12H35-
7.5	7.5						$M_N$						
23.5	24.1						$M_{0,max}$						
23.5	24.1						$M_{max}$						
-	-						$\eta_{eto}$						
15.0	15.0							$M_0$	2.80	5.9	1950	13.5	12L20-
13.5	13.5						$M_N$						
40.8	41.9						$M_{0,max}$						
40.8	41.9						$M_{max}$						
-	-						$\eta_{eto}$						
14.0	15.0	15.0	15.0	15.0				$M_0$	4.70	10.2	4050	11.0	12L41-
10.2	11.0	11.0	11.0	11.0			$M_N$						
22.2	30.4	35.5	35.5	35.5			$M_{0,max}$						
22.2	30.4	49.6	49.6	49.6			$M_{max}$						
-	-	-	-	-			$\eta_{eto}$						

►  $I...$  [A],  $M...$  [Nm],  $n...$  [r/min],  $P...$  [kW]

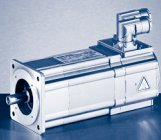

# MCS synchronous servo motors

Selection tables for Inverter Drives 8400 TopLine

## Mains connection 3 x 400 V and switching frequency 8 kHz

### Motors without blower

					E84AVTC	□3714	□5514	□7514	□1124	□1524	□2224	□3024
					$I_N$	1.3	1.8	2.4	3.2	3.9	5.9	7.3
					$I_{0,max}$	2.0	2.7	3.6	4.8	5.9	8.4	11.0
MCS	$M_N$	$n_N$	$I_N$	$P_N$	$I_{max}$	2.6	3.6	4.8	6.4	7.8	11.8	14.6
14D15-	9.2	1500	4.5	1.45	$M_0$				7.0	8.5	11.0	11.0
					$M_N$				6.6	8.0	9.2	9.2
					$M_{0,max}$				13.1	16.0	22.7	28.1
					$M_{max}$				13.1	16.0	22.7	28.1
					$n_{eto}$				-	-	-	-
14D36-	7.5	3600	7.5	2.80	$M_0$							8.0
					$M_N$							7.3
					$M_{0,max}$							15.2
					$M_{max}$							15.2
					$n_{eto}$							-
14H15-	16.0	1500	6.6	2.50	$M_0$							17.3
					$M_N$							16.0
					$M_{0,max}$							35.3
					$M_{max}$							35.3
					$n_{eto}$							-
14H32-	14.0	3225	11.9	4.70	$M_0$							
					$M_N$							
					$M_{0,max}$							
					$M_{max}$							
					$n_{eto}$							
14L15-	23.0	1500	9.7	3.60	$M_0$							
					$M_N$							
					$M_{0,max}$							
					$M_{max}$							
					$n_{eto}$							
14L32-	17.2	3225	15.0	5.80	$M_0$							
					$M_N$							
					$M_{0,max}$							
					$M_{max}$							
					$n_{eto}$							
14P14-	30.0	1350	10.8	4.20	$M_0$							
					$M_N$							
					$M_{0,max}$							
					$M_{max}$							
					$n_{eto}$							
14P32-	21.0	3225	15.6	7.10	$M_0$							
					$M_N$							
					$M_{0,max}$							
					$M_{max}$							
					$n_{eto}$							
19F14-	27.0	1425	8.6	4.00	$M_0$							23.6
					$M_N$							22.9
					$M_{0,max}$							45.9
					$M_{max}$							45.9
					$n_{eto}$							-
19F30-	21.0	3000	14.0	6.60	$M_0$							
					$M_N$							
					$M_{0,max}$							
					$M_{max}$							
					$n_{eto}$							

►  $I...$  [A],  $M...$  [Nm],  $n...$  [r/min],  $P...$  [kW]

# MCS synchronous servo motors

## Selection tables for Inverter Drives 8400 TopLine

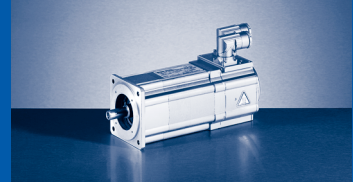

### Mains connection 3 x 400 V and switching frequency 8 kHz

#### Motors without blower

□4024	□5524	□7524	□1134	□1534	□1834	□2234	□3034	E84AVTC					
9.5	13.0	16.5	23.5	32.0	39.0	47.0	61.0	$I_N$					
14.3	19.5	26.4	32.9	43.2	60.0	70.5	91.5	$I_{0,max}$					
19.0	26.0	33.0	47.0	64.0	78.0	94.0	122.0	$I_{max}$	$P_N$	$I_N$	$n_N$	$M_N$	MCS
11.0	11.0							$M_0$	1.45	4.5	1500	9.2	14D15-
9.2	9.2							$M_N$					
28.3	29.0							$M_{0,max}$					
28.3	29.0							$M_{max}$					
-	-							$n_{eto}$					
11.0	11.0	11.0	11.0					$M_0$	2.80	7.5	3600	7.5	14D36-
7.5	7.5	7.5	7.5					$M_N$					
18.5	25.3	29.0	29.0					$M_{0,max}$					
18.5	22.2	22.2	22.2					$M_{max}$					
-	-	-	-					$n_{eto}$					
21.0	21.0							$M_0$	2.50	6.6	1500	16.0	14H15-
16.0	16.0							$M_N$					
42.8	43.9							$M_{0,max}$					
42.8	43.9							$M_{max}$					
-	-							$n_{eto}$					
12.9	16.2	21.0	21.0	21.0				$M_0$	4.70	11.9	3225	14.0	14H32-
11.2	14.0	14.0	14.0	14.0				$M_N$					
23.2	31.7	37.1	37.1	37.1				$M_{0,max}$					
23.2	31.7	51.9	51.9	51.9				$M_{max}$					
-	-	-	-	-				$n_{eto}$					
27.4	28.0	28.0	28.0					$M_0$	3.60	9.7	1500	23.0	14L15-
22.5	23.0	23.0	23.0					$M_N$					
43.8	52.9	52.9	52.9					$M_{0,max}$					
43.8	60.0	73.8	73.8					$M_{max}$					
-	-	-	-					$n_{eto}$					
	15.2	27.4	27.4	28.0	28.0	28.0		$M_0$	5.80	15.0	3225	17.2	14L32-
	14.9	17.2	17.2	17.2	17.2	17.2		$M_N$					
	31.3	39.7	52.9	52.9	52.9	52.9		$M_{0,max}$					
	31.3	57.6	73.9	73.9	73.9	73.9		$M_{max}$					
	-	-	-	-	-	-		$n_{eto}$					
32.5	37.0	37.0	37.0	37.0				$M_0$	4.20	10.8	1350	30.0	14P14-
26.4	30.0	30.0	30.0	30.0				$M_N$					
51.2	70.0	80.0	80.0	80.0				$M_{0,max}$					
51.2	70.0	105.1	105.1	105.1				$M_{max}$					
-	-	-	-	-				$n_{eto}$					
	19.8	35.8	35.8	37.0	37.0	37.0		$M_0$	7.10	15.6	3225	21.0	14P32-
	17.5	21.0	21.0	21.0	21.0	21.0		$M_N$					
	36.5	46.3	61.8	61.8	61.8	61.8		$M_{0,max}$					
	36.5	67.3	86.4	86.4	86.4	86.4		$M_{max}$					
	-	-	-	-	-	-		$n_{eto}$					
32.0	32.0	32.0	32.0					$M_0$	4.00	8.6	1425	27.0	19F14-
27.0	27.0	27.0	27.0					$M_N$					
56.7	68.3	68.3	68.3					$M_{0,max}$					
56.7	77.6	86.0	86.0					$M_{max}$					
-	-	-	-					$n_{eto}$					
	21.0	32.0	32.0	32.0				$M_0$	6.60	14.0	3000	21.0	19F30-
	19.5	21.0	21.0	21.0				$M_N$					
	47.2	47.2	47.2	47.2				$M_{0,max}$					
	38.9	68.3	68.3	68.3				$M_{max}$					
	-	-	-	-				$n_{eto}$					

►  $I...$  [A],  $M...$  [Nm],  $n...$  [r/min],  $P...$  [kW]

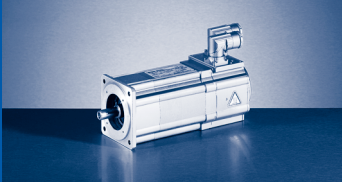

# MCS synchronous servo motors

Selection tables for Inverter Drives 8400 TopLine

**Mains connection 3 x 400 V and switching frequency  
8 kHz**

## Motors without blower

					E84AVTC	□3714	□5514	□7514	□1124	□1524	□2224	□3024
					$I_N$	1.3	1.8	2.4	3.2	3.9	5.9	7.3
					$I_{0,max}$	2.0	2.7	3.6	4.8	5.9	8.4	11.0
MCS	$M_N$	$n_N$	$I_N$	$P_N$	$I_{max}$	2.6	3.6	4.8	6.4	7.8	11.8	14.6
19J14-	40.0	1425	12.3	6.00	$M_0$							
					$M_N$							
					$M_{0,max}$							
					$M_{max}$							
					$n_{eto}$							
19J30-	29.0	3000	18.5	9.10	$M_0$							
					$M_N$							
					$M_{0,max}$							
					$M_{max}$							
					$n_{eto}$							
19P14-	51.0	1350	14.3	7.20	$M_0$							
					$M_N$							
					$M_{0,max}$							
					$M_{max}$							
					$n_{eto}$							
19P30-	32.0	3000	19.0	10.00	$M_0$							
					$M_N$							
					$M_{0,max}$							
					$M_{max}$							
					$n_{eto}$							

►  $I...$  [A],  $M...$  [Nm],  $n...$  [r/min],  $P...$  [kW]

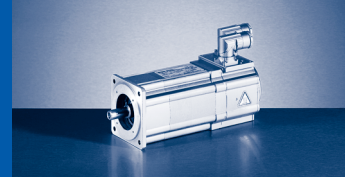

## Mains connection 3 x 400 V and switching frequency 8 kHz

### Motors without blower

□4024	□5524	□7524	□1134	□1534	□1834	□2234	□3034	E84AVTC					
9.5	13.0	16.5	23.5	32.0	39.0	47.0	61.0	$I_N$					
14.3	19.5	26.4	32.9	43.2	60.0	70.5	91.5	$I_{0,max}$					
19.0	26.0	33.0	47.0	64.0	78.0	94.0	122.0	$I_{max}$	$P_N$	$I_N$	$n_N$	$M_N$	MCS
	43.6	51.0	51.0	51.0				$M_0$	6.00	12.3	1425	40.0	19J14-
	40.0	40.0	40.0	40.0				$M_N$					
	81.1	96.0	96.0	96.0				$M_{0,max}$					
	81.1	129.0	129.0	129.0				$M_{max}$					
	-	-	-	-				$n_{eto}$					
			39.3	51.0	51.0	51.0	51.0	$M_0$	9.10	18.5	3000	29.0	19J30-
			29.0	29.0	29.0	29.0	29.0	$M_N$					
			73.6	79.5	79.5	79.5	79.5	$M_{0,max}$					
			110.4	127.6	127.6	127.6	127.6	$M_{max}$					
			-	-	-	-	-	$n_{eto}$					
	47.5	64.0	64.0	64.0				$M_0$	7.20	14.3	1350	51.0	19P14-
	46.4	51.0	51.0	51.0				$M_N$					
	92.7	106.7	106.7	106.7				$M_{0,max}$					
	92.7	155.5	155.5	155.5				$M_{max}$					
	-	-	-	-				$n_{eto}$					
			43.1	58.7	64.0	64.0	64.0	$M_0$	10.00	19.0	3000	32.0	19P30-
			32.0	32.0	32.0	32.0	32.0	$M_N$					
			79.2	87.6	87.6	87.6	87.6	$M_{0,max}$					
			118.6	144.3	144.3	144.3	144.3	$M_{max}$					
			-	-	-	-	-	$n_{eto}$					

► I... [A], M... [Nm], n... [r/min], P... [kW]



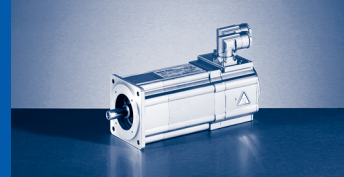

## Mains connection 3 x 400 V and switching frequency 8 kHz

### Motors with blower

					E84AVTC	□1124	□1524	□2224	□3024	□4024	□5524	□7524	□1134	□1534	□1834	□2234	□3034	
					I <sub>N</sub>	3.2	3.9	5.9	7.3	9.5	13.0	16.5	23.5	32.0	39.0	47.0	61.0	
					I <sub>0,max</sub>	4.8	5.9	8.4	11.0	14.3	19.5	26.4	32.9	43.2	60.0	70.5	91.5	
MCS	M <sub>N</sub>	n <sub>N</sub>	I <sub>N</sub>	P <sub>N</sub>	I <sub>max</sub>	6.4	7.8	11.8	14.6	19.0	26.0	33.0	47.0	64.0	78.0	94.0	122.0	
14L14-	30.5	1350	11.8	4.30	M <sub>0</sub>					26.9	33.4	34.5	34.5					
					M <sub>N</sub>					24.6	30.5	30.5	30.5					
					M <sub>0,max</sub>					43.8	52.9	52.9	52.9					
					M <sub>max</sub>					43.8	60.0	73.8	73.8					
					η <sub>eto</sub>					-	-	-	-					
14L30-	25.5	3000	20.8	8.00	M <sub>0</sub>								27.4	34.5	34.5	34.5		
					M <sub>N</sub>								25.5	25.5	25.5	25.5		
					M <sub>0,max</sub>								52.9	52.9	52.9	52.9		
					M <sub>max</sub>								73.9	73.9	73.9	73.9		
					η <sub>eto</sub>								-	-	-	-		
14P11-	42.0	1050	13.4	4.60	M <sub>0</sub>						38.9	43.5	43.5	43.5				
					M <sub>N</sub>						38.8	42.0	42.0	42.0				
					M <sub>0,max</sub>						70.0	80.0	80.0	80.0				
					M <sub>max</sub>						70.0	105.1	105.1	105.1				
					η <sub>eto</sub>						-	-	-	-				
14P26-	33.0	2625	21.9	9.10	M <sub>0</sub>								35.8	43.5	43.5	43.5		
					M <sub>N</sub>								33.0	33.0	33.0	33.0		
					M <sub>0,max</sub>								66.0	86.4	86.4	86.4		
					M <sub>max</sub>								86.4	86.4	86.4	86.4		
					η <sub>eto</sub>								-	-	-	-		
19F12-	38.0	1200	11.3	4.80	M <sub>0</sub>			23.6	34.9	41.5	41.5	41.5						
					M <sub>N</sub>			22.9	31.9	38.0	38.0	38.0						
					M <sub>0,max</sub>			45.9	56.7	68.3	68.3	68.3						
					M <sub>max</sub>			45.9	56.7	77.6	86.0	86.0						
					η <sub>eto</sub>			-	-	-	-	-						
19F29-	32.5	2850	20.1	9.70	M <sub>0</sub>								39.9	41.5				
					M <sub>N</sub>								32.5	32.5				
					M <sub>0,max</sub>								47.2	47.2				
					M <sub>max</sub>								68.3	68.3				
					η <sub>eto</sub>								-	-				
19J12-	62.5	1200	18.3	7.90	M <sub>0</sub>						43.6		70.5	70.5				
					M <sub>N</sub>						43.4		62.5	62.5				
					M <sub>0,max</sub>						81.1		96.0	96.0				
					M <sub>max</sub>						81.1		129.0	129.0				
					η <sub>eto</sub>						-		-	-				
19J29-	50.5	2850	31.0	15.10	M <sub>0</sub>									55.5	70.5	70.5	70.5	
					M <sub>N</sub>									50.5	50.5	50.5	50.5	
					M <sub>0,max</sub>									87.6	87.6	87.6	87.6	
					M <sub>max</sub>									127.6	127.6	127.6	127.6	
					η <sub>eto</sub>									-	-	-	-	
19P12-	72.0	1200	21.3	9.00	M <sub>0</sub>						47.5		86.0	86.0				
					M <sub>N</sub>						46.4		72.0	72.0				
					M <sub>0,max</sub>						92.7		106.7	106.7				
					M <sub>max</sub>						92.7		155.5	155.5				
					η <sub>eto</sub>						-		-	-				
19P29-	53.0	2850	29.5	15.80	M <sub>0</sub>									58.7	86.0	86.0	86.0	
					M <sub>N</sub>									53.0	53.0	53.0	53.0	
					M <sub>0,max</sub>									87.6	87.6	87.6	87.6	
					M <sub>max</sub>									144.3	144.3	144.3	144.3	
					η <sub>eto</sub>									-	-	-	-	

► I... [A], M... [Nm], n... [r/min], P... [kW]

3

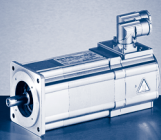

# MCS synchronous servo motors

## ECS servo system selection tables

### Mains connection 3 x 400 V and switching frequency 4 kHz

#### Motors without blower

					ECS□□	004C□B	008C□B	016C□B	032C□B	048C□B	064C□B
					$I_N$	2.0	4.0	8.0	12.7	17.0	20.0
					$I_{0,max}$	2.3	4.6	9.1	18.1	27.2	36.3
MCS	$M_N$	$n_N$	$I_N$	$P_N$	$I_{max}$	4.0	8.0	16.0	32.0	48.0	64.0
06C41-	0.6	4050	1.3	0.25	$M_0$	0.8					
					$M_N$	0.6					
					$M_{0,max}$	1.2					
					$M_{max}$	1.9					
					$n_{eto}$	2747					
06C60-	0.5	6000	2.4	0.31	$M_0$	0.6	0.8				
					$M_N$	0.4	0.5				
					$M_{0,max}$	0.6	1.2				
					$M_{max}$	1.0	1.9				
					$n_{eto}$	7000	6814				
06F41-	1.2	4050	1.5	0.51	$M_0$	1.5					
					$M_N$	1.2					
					$M_{0,max}$	2.0					
					$M_{max}$	3.6					
					$n_{eto}$	1902					
06F60-	0.9	6000	2.5	0.57	$M_0$	1.0	1.5				
					$M_N$	0.7	0.9				
					$M_{0,max}$	1.0	2.0				
					$M_{max}$	1.8	3.7				
					$n_{eto}$	7000	4602				
06I41-	1.5	4050	1.6	0.64	$M_0$	2.0	2.0				
					$M_N$	1.5	1.5				
					$M_{0,max}$	2.6	5.0				
					$M_{max}$	4.4	6.2				
					$n_{eto}$	1898	1384				
06I60-	1.2	6000	2.9	0.75	$M_0$	1.2	2.0	2.0			
					$M_N$	0.8	1.2	1.2			
					$M_{0,max}$	1.3	2.6	5.2			
					$M_{max}$	2.2	4.7	6.2			
					$n_{eto}$	6407	4200	3157			
09D41-	2.3	4050	2.3	1.00	$M_0$		3.3	3.3			
					$M_N$		2.3	2.3			
					$M_{0,max}$		5.0	8.8			
					$M_{max}$		8.0	9.4			
					$n_{eto}$		2361	2008			
09D60-	1.8	6000	3.8	1.10	$M_0$		2.5	3.3			
					$M_N$		1.8	1.8			
					$M_{0,max}$		2.5	4.9			
					$M_{max}$		4.4	8.0			
					$n_{eto}$		7000	5217			
09F38-	3.1	3750	2.5	1.20	$M_0$		4.2	4.2			
					$M_N$		3.1	3.1			
					$M_{0,max}$		6.2	10.8			
					$M_{max}$		9.8	14.9			
					$n_{eto}$		2589	1737			
09F60-	2.4	6000	4.5	1.50	$M_0$		2.8	4.2	4.2		
					$M_N$		2.1	2.4	2.4		
					$M_{0,max}$		3.2	6.1	10.8		
					$M_{max}$		5.4	9.8	14.9		
					$n_{eto}$		7000	5906	3715		

► I... [A], M... [Nm], n... [r/min], P... [kW]



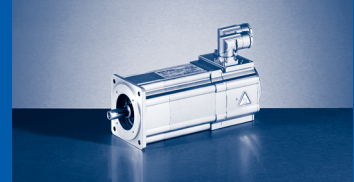

### Mains connection 3 x 400 V and switching frequency 4 kHz

#### Motors without blower

					ECS□□	004C□B	008C□B	016C□B	032C□B	048C□B	064C□B
					$I_N$	2.0	4.0	8.0	12.7	17.0	20.0
					$I_{0,max}$	2.3	4.6	9.1	18.1	27.2	36.3
MCS	$M_N$	$n_N$	$I_N$	$P_N$	$I_{max}$	4.0	8.0	16.0	32.0	48.0	64.0
09H41-	3.8	4050	3.4	1.60	$M_0$		5.2	5.5			
					$M_N$		3.8	3.8			
					$M_{0,max}$		5.9	11.1			
					$M_{max}$		9.9	17.5			
					$n_{eto}$		3675	2231			
09H60-	3.0	6000	6.0	1.90	$M_0$			5.2	5.5	5.5	
					$M_N$			3.0	3.0	3.0	
					$M_{0,max}$			5.9	11.0	15.5	
					$M_{max}$			9.9	17.5	20.4	
					$n_{eto}$			7000	5061	4375	
09L41-	4.5	4050	4.2	1.90	$M_0$		4.8	7.5	7.5		
					$M_N$		4.3	4.5	4.5		
					$M_{0,max}$		5.2	10.3	19.5		
					$M_{max}$		9.1	17.4	31.9		
					$n_{eto}$		4450	3188	1878		
09L51-	3.6	5100	6.9	1.90	$M_0$			4.8	7.5	7.5	7.5
					$M_N$			3.6	3.6	3.6	3.6
					$M_{0,max}$			5.2	10.3	15.1	19.6
					$M_{max}$			9.1	17.5	25.1	31.9
					$n_{eto}$			7000	7000	5647	4076
12D20-	5.5	1950	2.6	1.10	$M_0$	4.7	6.4	6.4			
					$M_N$	4.2	5.5	5.5			
					$M_{0,max}$	4.6	9.1	17.0			
					$M_{max}$	8.0	15.3	17.7			
					$n_{eto}$	1730	1089	919			
12D41-	4.3	4050	4.5	1.80	$M_0$		4.7	6.4			
					$M_N$		3.8	4.3			
					$M_{0,max}$		4.6	8.8			
					$M_{max}$		7.8	14.7			
					$n_{eto}$		3902	2433			
12H15-	10.0	1500	3.8	1.60	$M_0$		11.2	11.4			
					$M_N$		10.0	10.0			
					$M_{0,max}$		11.9	22.6			
					$M_{max}$		20.1	29.0			
					$n_{eto}$		1220	918			
12H35-	7.5	3525	5.7	2.80	$M_0$		5.6	11.2	11.4		
					$M_N$		5.3	7.5	7.5		
					$M_{0,max}$		6.0	11.8	22.5		
					$M_{max}$		10.4	20.1	29.0		
					$n_{eto}$		3850	2838	2092		
12L20-	13.5	1950	5.9	2.80	$M_0$			15.0	15.0		
					$M_N$			13.5	13.5		
					$M_{0,max}$			21.4	39.4		
					$M_{max}$			35.5	56.4		
					$n_{eto}$			1324	863		
12L41-	11.0	4050	10.2	4.70	$M_0$			9.7	15.0	15.0	15.0
					$M_N$			8.6	11.0	11.0	11.0
					$M_{0,max}$			10.8	21.3	30.8	39.5
					$M_{max}$			19.0	35.5	49.6	56.4
					$n_{eto}$			4450	3013	2236	1907

►  $I...$  [A],  $M...$  [Nm],  $n...$  [r/min],  $P...$  [kW]

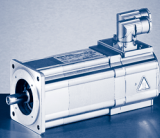

# MCS synchronous servo motors

## ECS servo system selection tables

### Mains connection 3 x 400 V and switching frequency 4 kHz

#### Motors without blower

					ECS□□	004C□B	008C□B	016C□B	032C□B	048C□B	064C□B	
					$I_N$	2.0	4.0	8.0	12.7	17.0	20.0	
					$I_{0,max}$	2.3	4.6	9.1	18.1	27.2	36.3	
MCS	$M_N$	$n_N$	$I_N$	$P_N$	$I_{max}$	4.0	8.0	16.0	32.0	48.0	64.0	
14D15-	9.2	1500	4.5	1.45	$M_0$		8.8	11.0				
					$M_N$		8.2	9.2				
					$M_{0,max}$		9.6	17.9				
					$M_{max}$		15.9	28.3				
					$n_{eto}$		1141	689				
14D36-	7.5	3600	7.5	2.80	$M_0$			8.8	11.0			
					$M_N$			7.5	7.5			
					$M_{0,max}$			9.5	17.8			
					$M_{max}$			15.9	28.3			
					$n_{eto}$			2496	1614			
14H15-	16.0	1500	6.6	2.50	$M_0$			19.8	21.0			
					$M_N$			16.0	16.0			
					$M_{0,max}$			22.3	41.2			
					$M_{max}$			37.1	54.8			
					$n_{eto}$			920	667			
14H32-	14.0	3225	11.9	4.70	$M_0$				15.8	21.0	21.0	
					$M_N$				14.0	14.0	14.0	
					$M_{0,max}$				22.2	32.1	41.3	
					$M_{max}$				37.1	51.9	54.8	
					$n_{eto}$				1953	1471	1409	
14L15-	23.0	1500	9.7	3.60	$M_0$			18.7	28.0	28.0		
					$M_N$			19.0	23.0	23.0		
					$M_{0,max}$			21.9	42.1	59.9		
					$M_{max}$			37.6	68.5	77.1		
					$n_{eto}$			1284	828	767		
14L32-	17.2	3225	15.0	5.80	$M_0$				14.8	19.8	23.3	
					$M_N$				14.6	17.2	17.2	
					$M_{0,max}$				21.8	32.4	42.2	
					$M_{max}$				37.6	53.9	68.5	
					$n_{eto}$				2801	2096	1757	
14P14-	30.0	1350	10.8	4.20	$M_0$				37.0	37.0	37.0	
					$M_N$				30.0	30.0	30.0	
					$M_{0,max}$				49.1	70.0	88.4	
					$M_{max}$				80.0	105.1	105.1	
					$n_{eto}$				710	573	573	
14P32-	21.0	3225	15.6	7.10	$M_0$				19.3	25.9	30.5	
					$M_N$				17.1	21.0	21.0	
					$M_{0,max}$				25.4	37.9	49.3	
					$M_{max}$				43.9	63.0	80.0	
					$n_{eto}$				2469	1829	1495	
19F14-	27.0	1425	8.6	4.00	$M_0$			25.9	32.0			
					$M_N$			25.1	27.0			
					$M_{0,max}$			28.6	54.6			
					$M_{max}$			48.9	86.0			
					$n_{eto}$			1204	746			
19F30-	21.0	3000	14.0	6.60	$M_0$				20.5	27.5	32.0	
					$M_N$				19.0	21.0	21.0	
					$M_{0,max}$				27.2	40.5	53.0	
					$M_{max}$				47.2	68.3	86.0	
					$n_{eto}$				2774	2033	1653	

► I... [A], M... [Nm], n... [r/min], P... [kW]

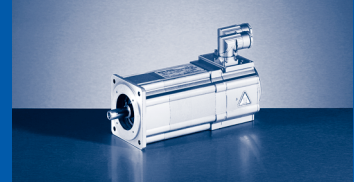

### Mains connection 3 x 400 V and switching frequency 4 kHz

#### Motors without blower

					ECS□□	004C□B	008C□B	016C□B	032C□B	048C□B	064C□B
					$I_N$	2.0	4.0	8.0	12.7	17.0	20.0
					$I_{0,max}$	2.3	4.6	9.1	18.1	27.2	36.3
MCS	$M_N$	$n_N$	$I_N$	$P_N$	$I_{max}$	4.0	8.0	16.0	32.0	48.0	64.0
19J14-	40.0	1425	12.3	6.00	$M_0$				42.6	51.0	
					$M_N$				40.0	40.0	
					$M_{0,max}$				58.9	82.8	
					$M_{max}$				96.0	129.0	
					$n_{eto}$				1063	839	
19J30-	29.0	3000	18.5	9.10	$M_0$					28.4	33.4
					$M_N$					26.6	29.0
					$M_{0,max}$					42.6	56.9
					$M_{max}$					73.8	96.0
					$n_{eto}$					2850	2323
19P14-	51.0	1350	14.3	7.20	$M_0$				46.4	62.2	64.0
					$M_N$				45.3	51.0	51.0
					$M_{0,max}$				64.6	91.5	120.1
					$M_{max}$				106.7	155.5	190.0
					$n_{eto}$				1227	996	870
19P30-	32.0	3000	19.0	10.00	$M_0$					31.2	36.7
					$M_N$					28.6	32.0
					$M_{0,max}$					45.8	61.1
					$M_{max}$					81.2	106.7
					$n_{eto}$					2938	2715

►  $I...$  [A],  $M...$  [Nm],  $n...$  [r/min],  $P...$  [kW]

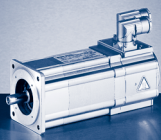

# MCS synchronous servo motors

## ECS servo system selection tables

### Mains connection 3 x 400 V and switching frequency 4 kHz

#### Motors with blower

					ECS□□	004C□B	008C□B	016C□B	032C□B	048C□B	064C□B
					$I_N$	2.0	4.0	8.0	12.7	17.0	20.0
					$I_{0,max}$	2.3	4.6	9.1	18.1	27.2	36.3
MCS	$M_N$	$n_N$	$I_N$	$P_N$	$I_{max}$	4.0	8.0	16.0	32.0	48.0	64.0
12D17-	7.0	1650	3.0	1.20	$M_0$	4.7	7.5	7.5			
					$M_N$	4.2	7.0	7.0			
					$M_{0,max}$	4.6	9.1	17.0			
					$M_{max}$	8.0	15.3	17.7			
					$n_{eto}$	1730	1089	919			
12D35-	6.0	3525	5.6	2.20	$M_0$		4.7	7.5			
					$M_N$		3.8	6.0			
					$M_{0,max}$		4.6	8.8			
					$M_{max}$		7.8	14.7			
					$n_{eto}$		3902	2433			
12H14-	12.0	1350	4.1	1.70	$M_0$		11.2	12.8			
					$M_N$		10.6	12.0			
					$M_{0,max}$		11.9	22.6			
					$M_{max}$		20.1	29.0			
					$n_{eto}$		1220	918			
12H34-	10.5	3375	7.5	3.70	$M_0$		5.6	11.2	12.8		
					$M_N$		5.3	10.0	7.5		
					$M_{0,max}$		6.0	11.8	22.5		
					$M_{max}$		10.4	20.1	29.0		
					$n_{eto}$		3850	2838	2092		
12L17-	17.0	1650	6.7	2.90	$M_0$			19.0	19.0		
					$M_N$			17.0	17.0		
					$M_{0,max}$			21.4	39.4		
					$M_{max}$			35.5	56.4		
					$n_{eto}$			1324	863		
12L39-	14.0	3900	11.7	5.70	$M_0$			9.7	16.7	19.0	19.0
					$M_N$			8.6	14.0	14.0	14.0
					$M_{0,max}$			10.8	21.3	30.8	39.5
					$M_{max}$			19.0	35.5	49.6	56.4
					$n_{eto}$			4450	3013	2236	1907
14D14-	12.0	1350	5.4	1.70	$M_0$		8.8	12.5			
					$M_N$		8.2	12.0			
					$M_{0,max}$		9.6	17.9			
					$M_{max}$		15.9	28.3			
					$n_{eto}$		1141	689			
14D30-	10.5	3000	9.7	3.30	$M_0$			8.8	11.4		
					$M_N$			8.6	9.7		
					$M_{0,max}$			9.5	17.8		
					$M_{max}$			15.9	28.3		
					$n_{eto}$			2496	1614		
14H12-	23.5	1200	8.3	3.00	$M_0$			19.8	25.5		
					$M_N$			19.6	23.5		
					$M_{0,max}$			22.3	41.2		
					$M_{max}$			37.1	54.8		
					$n_{eto}$			920	667		
14H28-	20.5	2775	15.0	6.00	$M_0$				15.8	23.5	25.5
					$M_N$				15.6	20.5	20.5
					$M_{0,max}$				22.2	32.1	41.3
					$M_{max}$				37.1	51.9	54.8
					$n_{eto}$				1953	1471	1409

► I... [A], M... [Nm], n... [r/min], P... [kW]

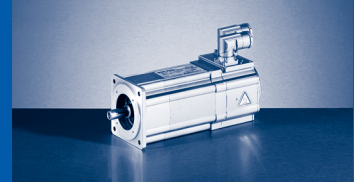

### Mains connection 3 x 400 V and switching frequency 4 kHz

#### Motors with blower

					ECS□□	004C□B	008C□B	016C□B	032C□B	048C□B	064C□B
					$I_N$	2.0	4.0	8.0	12.7	17.0	20.0
					$I_{0,max}$	2.3	4.6	9.1	18.1	27.2	36.3
MCS	$M_N$	$n_N$	$I_N$	$P_N$	$I_{max}$	4.0	8.0	16.0	32.0	48.0	64.0
14L14-	30.5	1350	11.8	4.30	$M_0$			18.7	32.7	34.5	
					$M_N$			19.0	30.5	30.5	
					$M_{0,max}$			21.9	42.1	59.9	
					$M_{max}$			37.6	68.5	77.1	
					$n_{eto}$			1284	828	767	
14L30-	25.5	3000	20.8	8.00	$M_0$					19.8	23.3
					$M_N$					19.7	23.3
					$M_{0,max}$					32.4	42.2
					$M_{max}$					53.9	68.5
					$n_{eto}$					2096	1757
14P11-	42.0	1050	13.4	4.60	$M_0$				39.1	43.5	43.5
					$M_N$				38.9	42.0	42.0
					$M_{0,max}$				49.1	70.0	88.4
					$M_{max}$				80.0	105.1	105.1
					$n_{eto}$				710	573	573
14P26-	33.0	2625	21.9	9.10	$M_0$					25.9	30.5
					$M_N$					25.6	30.1
					$M_{0,max}$					37.9	49.3
					$M_{max}$					63.0	80.0
					$n_{eto}$					1829	1495
19F12-	38.0	1200	11.3	4.80	$M_0$			25.9	41.5		
					$M_N$			25.1	38.0		
					$M_{0,max}$			28.6	54.6		
					$M_{max}$			48.9	86.0		
					$n_{eto}$			1204	746		
19F29-	32.5	2850	20.1	9.70	$M_0$					27.5	33.9
					$M_N$					27.4	32.5
					$M_{0,max}$					40.5	53.0
					$M_{max}$					68.3	86.0
					$n_{eto}$					2033	1653
19J12-	62.5	1200	18.3	7.90	$M_0$					59.0	69.4
					$M_N$					58.1	62.5
					$M_{0,max}$					82.8	82.8
					$M_{max}$					129.0	129.0
					$n_{eto}$					839	839
19J29-	50.5	2850	31.0	15.10	$M_0$						34.3
					$M_N$						32.6
					$M_{0,max}$						56.9
					$M_{max}$						96.0
					$n_{eto}$						2323
19P12-	72.0	1200	21.3	9.00	$M_0$					62.2	76.8
					$M_N$					57.5	67.6
					$M_{0,max}$					91.5	120.1
					$M_{max}$					155.5	190.0
					$n_{eto}$					996	870
19P29-	53.0	2850	29.5	15.80	$M_0$						36.7
					$M_N$						35.9
					$M_{0,max}$						61.1
					$M_{max}$						106.7
					$n_{eto}$						2715

► I... [A], M... [Nm], n... [r/min], P... [kW]

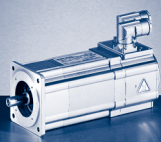

# MCS synchronous servo motors

## ECS servo system selection tables

### Mains connection 3 x 230 V and switching frequency 4 kHz

#### Motors without blower

					ECS□□	004C□B	008C□B	016C□B	032C□B	048C□B	064C□B
					$I_N$	2.0	4.0	8.0	12.7	17.0	20.0
					$I_{0,max}$	2.3	4.6	9.1	18.1	27.2	36.3
MCS	$M_N$	$n_N$	$I_N$	$P_N$	$I_{max}$	4.0	8.0	16.0	32.0	48.0	64.0
06C41L	0.6	4050	2.6	0.25	$M_0$	0.6	0.8				
					$M_N$	0.5	0.6				
					$M_{0,max}$	0.6	1.1				
					$M_{max}$	1.0	1.9				
					$n_{eto}$	6298	2835				
06C60L	0.5	6000	4.0	0.31	$M_0$		0.7	0.8			
					$M_N$		0.5	0.5			
					$M_{0,max}$		0.7	1.3			
					$M_{max}$		1.2	2.2			
					$n_{eto}$		7000	1149			
06F41L	1.2	4050	2.9	0.51	$M_0$	1.0	1.5	1.5			
					$M_N$	0.8	1.2	1.2			
					$M_{0,max}$	1.2	2.1	3.9			
					$M_{max}$	1.9	3.5	4.4			
					$n_{eto}$	3838	2118	2831			
06F60L	0.9	6000	3.8	0.57	$M_0$		1.5	1.5			
					$M_N$		0.9	0.9			
					$M_{0,max}$		1.5	2.9			
					$M_{max}$		2.6	4.3			
					$n_{eto}$		6138	3182			
06I41L	1.5	4050	3.2	0.64	$M_0$	1.3	2.0	2.0			
					$M_N$	1.0	1.5	1.5			
					$M_{0,max}$	1.4	2.8	5.0			
					$M_{max}$	2.4	4.4	6.2			
					$n_{eto}$	3549	1947	2831			
06I60L	1.2	6000	3.8	0.75	$M_0$		1.9	2.0			
					$M_N$		1.2	1.2			
					$M_{0,max}$		2.1	4.1			
					$M_{max}$		3.6	6.2			
					$n_{eto}$		3417	1149			
09D41L	2.3	4050	4.6	1.00	$M_0$		2.5	3.3	3.3		
					$M_N$		2.0	2.3	2.3		
					$M_{0,max}$		2.5	4.9	8.8		
					$M_{max}$		4.4	8.0	9.5		
					$n_{eto}$		4091	2547	2170		
09D60L	1.8	6000	7.0	1.10	$M_0$			2.6	3.3	3.3	
					$M_N$			1.8	1.8	1.8	
					$M_{0,max}$			2.6	5.0	7.1	
					$M_{max}$			4.5	8.1	9.5	
					$n_{eto}$			7000	5373	4626	
09F38L	3.1	3750	5.0	1.20	$M_0$			4.2	4.2		
					$M_N$			3.1	3.1		
					$M_{0,max}$			6.1	10.8		
					$M_{max}$			9.8	15.0		
					$n_{eto}$			1149	1951		
09F60L	2.4	6000	7.9	1.50	$M_0$			3.2	4.2	4.2	4.2
					$M_N$			2.4	2.4	2.4	2.4
					$M_{0,max}$			3.6	6.8	9.6	11.9
					$M_{max}$			6.1	10.9	14.3	15.0
					$n_{eto}$			6985	3448	2612	2397

► I... [A], M... [Nm], n... [r/min], P... [kW]

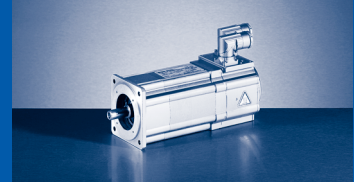

### Mains connection 3 x 230 V and switching frequency 4 kHz

#### Motors without blower

					ECS□□	004C□B	008C□B	016C□B	032C□B	048C□B	064C□B
					$I_N$	2.0	4.0	8.0	12.7	17.0	20.0
					$I_{0,max}$	2.3	4.6	9.1	18.1	27.2	36.3
MCS	$M_N$	$n_N$	$I_N$	$P_N$	$I_{max}$	4.0	8.0	16.0	32.0	48.0	64.0
09H41L	3.8	4050	6.8	1.60	$M_0$			5.2	5.5	5.5	
					$M_N$			3.8	3.8	3.8	
					$M_{0,max}$			5.9	11.0	15.3	
					$M_{max}$			9.9	17.2	20.0	
					$n_{eto}$			1149	2138	1852	
09H60L	3.0	6000	8.0	1.90	$M_0$			3.7	5.5	5.5	5.5
					$M_N$			3.0	3.0	3.0	3.0
					$M_{0,max}$			4.1	8.0	11.5	14.5
					$M_{max}$			7.2	13.2	17.9	20.0
					$n_{eto}$			1149	4081	2984	2695
09L41L	4.5	4050	8.4	1.90	$M_0$			4.8	7.5	7.5	7.5
					$M_N$			4.3	4.5	4.5	4.5
					$M_{0,max}$			5.2	10.3	15.1	19.6
					$M_{max}$			9.1	17.5	25.1	31.9
					$n_{eto}$			4562	3243	2497	1909
12D20L	5.5	1950	5.2	1.10	$M_0$		4.7	6.4			
					$M_N$		4.2	5.5			
					$M_{0,max}$		4.6	9.0			
					$M_{max}$		8.0	14.9			
					$n_{eto}$		1878	1181			
12D41L	4.3	4050	8.8	1.80	$M_0$			4.8	6.4	6.4	
					$M_N$			3.9	4.3	4.3	
					$M_{0,max}$			4.6	9.2	13.3	
					$M_{max}$			8.1	15.2	17.9	
					$n_{eto}$			4102	2535	2187	
12H15L	10.0	1500	7.6	1.60	$M_0$			11.2	11.4		
					$M_N$			10.0	10.0		
					$M_{0,max}$			11.8	22.5		
					$M_{max}$			20.1	29.0		
					$n_{eto}$			1098	827		
12H30L	8.0	3000	10.5	2.50	$M_0$			6.8	10.7	11.4	
					$M_N$			6.1	8.0	8.0	
					$M_{0,max}$			7.2	14.3	20.9	
					$M_{max}$			12.7	24.3	29.0	
					$n_{eto}$			2831	1849	1591	
12L20L	13.5	1950	11.8	2.80	$M_0$				15.0	15.0	15.0
					$M_N$				13.5	13.5	13.5
					$M_{0,max}$				21.3	30.7	39.4
					$M_{max}$				35.4	49.3	56.0
					$n_{eto}$				1307	1004	866

►  $I...$  [A],  $M...$  [Nm],  $n...$  [r/min],  $P...$  [kW]

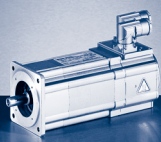

# MCS synchronous servo motors

## EVS9300 servo inverter selection tables

### Mains connection 3 x 400 V and switching frequency 8 kHz

#### Motors without blower

					EVS	9321-E□	9322-E□	9323-E□	9324-E□	9325-E□	9326-E□	9327-E□	9328-E□	9329-E□
					$I_N$	1.5	2.5	3.9	7.0	13.0	23.5	32.0	47.0	59.0
					$I_{0,max}$	2.3	3.8	5.9	10.5	19.5	23.5	32.0	47.0	52.0
MCS	$M_N$	$n_N$	$I_N$	$P_N$	$I_{max}$	2.3	3.8	5.9	10.5	19.5	35.3	48.0	70.5	88.5
06C41-	0.6	4050	1.3	0.25	$M_0$	0.8	0.8	0.8						
					$M_N$	0.6	0.6	0.6						
					$M_{0,max}$	1.2	1.8	2.4						
					$M_{max}$	1.2	1.8	2.4						
					$n_{eto}$	4635	2871	2019						
06C60-	0.5	6000	2.4	0.31	$M_0$		0.8	0.8	0.8					
					$M_N$		0.5	0.5	0.5					
					$M_{0,max}$		1.0	1.5	2.4					
					$M_{max}$		1.0	1.5	2.4					
					$n_{eto}$		7000	7000	5368					
06F41-	1.2	4050	1.5	0.51	$M_0$	1.5	1.5	1.5						
					$M_N$	1.2	1.2	1.2						
					$M_{0,max}$	2.0	3.4	4.4						
					$M_{max}$	2.0	3.4	4.4						
					$n_{eto}$	2819	1973	1562						
06F60-	0.9	6000	2.5	0.57	$M_0$		1.3	1.5	1.5					
					$M_N$		0.9	0.9	0.9					
					$M_{0,max}$		1.7	3.0	4.4					
					$M_{max}$		1.7	3.0	4.4					
					$n_{eto}$		7000	5714	3773					
06I41-	1.5	4050	1.6	0.64	$M_0$	1.8	2.0	2.0						
					$M_N$	1.4	1.5	1.5						
					$M_{0,max}$	2.6	4.2	6.2						
					$M_{max}$	2.6	4.2	6.2						
					$n_{eto}$	2994	1980	1384						
06I60-	1.2	6000	2.9	0.75	$M_0$		1.5	2.0	2.0					
					$M_N$		1.0	1.2	1.2					
					$M_{0,max}$		2.1	3.3	5.7					
					$M_{max}$		2.1	3.3	5.7					
					$n_{eto}$		7000	5486	3414					
09D41-	2.3	4050	2.3	1.00	$M_0$		3.1	3.3	3.3					
					$M_N$		2.3	2.3	2.3					
					$M_{0,max}$		4.2	6.2	9.4					
					$M_{max}$		4.2	6.2	9.4					
					$n_{eto}$		4895	2937	2008					
09D60-	1.8	6000	3.8	1.10	$M_0$			2.4	3.3	3.3				
					$M_N$			1.8	1.8	1.8				
					$M_{0,max}$			3.2	5.6	9.3				
					$M_{max}$			3.2	5.6	9.3				
					$n_{eto}$			7000	7000	4492				
09F38-	3.1	3750	2.5	1.20	$M_0$		3.5	4.2	4.2					
					$M_N$		3.1	3.1	3.1					
					$M_{0,max}$		5.2	7.7	12.0					
					$M_{max}$		5.2	7.7	12.0					
					$n_{eto}$		4000	3250	2173					
09F60-	2.4	6000	4.5	1.50	$M_0$				4.2	4.2				
					$M_N$				2.4	2.4				
					$M_{0,max}$				6.9	11.4				
					$M_{max}$				6.9	11.4				
					$n_{eto}$				7000	5035				

►  $I...$  [A],  $M...$  [Nm],  $n...$  [r/min],  $P...$  [kW]



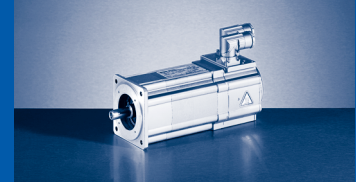

**Mains connection 3 x 400 V and switching frequency  
8 kHz**

**Motors without blower**

					EVS	9321-E□	9322-E□	9323-E□	9324-E□	9325-E□	9326-E□	9327-E□	9328-E□	9329-E□
					I <sub>N</sub>	1.5	2.5	3.9	7.0	13.0	23.5	32.0	47.0	59.0
					I <sub>0,max</sub>	2.3	3.8	5.9	10.5	19.5	23.5	32.0	47.0	52.0
MCS	M <sub>N</sub>	n <sub>N</sub>	I <sub>N</sub>	P <sub>N</sub>	I <sub>max</sub>	2.3	3.8	5.9	10.5	19.5	35.3	48.0	70.5	88.5
09H41-	3.8	4050	3.4	1.60	M <sub>0</sub>			5.0	5.5	5.5				
					M <sub>N</sub>			3.8	3.8	3.8				
					M <sub>0,max</sub>			7.5	12.5	20.1				
					M <sub>max</sub>			7.5	12.5	20.1				
					n <sub>eto</sub>			4250	2977	1988				
09H60-	3.0	6000	6.0	1.90	M <sub>0</sub>				4.5	5.5				
					M <sub>N</sub>				3.0	3.0				
					M <sub>0,max</sub>				6.7	11.7				
					M <sub>max</sub>				6.7	11.7				
					n <sub>eto</sub>				7000	7000				
09L41-	4.5	4050	4.2	1.90	M <sub>0</sub>			4.7	7.5	7.5				
					M <sub>N</sub>			4.2	4.5	4.5				
					M <sub>0,max</sub>			6.7	11.7	20.8				
					M <sub>max</sub>			6.7	11.7	20.8				
					n <sub>eto</sub>			4450	4154	2796				
09L51-	3.6	5100	6.9	1.90	M <sub>0</sub>				4.2	7.5	7.5			
					M <sub>N</sub>				3.6	3.6	3.6			
					M <sub>0,max</sub>				6.0	11.1	13.2			
					M <sub>max</sub>				6.0	11.1	19.1			
					n <sub>eto</sub>				7000	7000				
12D20-	5.5	1950	2.6	1.10	M <sub>0</sub>		5.9	6.4	6.4					
					M <sub>N</sub>		5.3	5.5	5.5					
					M <sub>0,max</sub>		7.6	11.6	17.7					
					M <sub>max</sub>		7.6	11.6	17.7					
					n <sub>eto</sub>		1790	1358	919					
12D41-	4.3	4050	4.5	1.80	M <sub>0</sub>			4.6	6.4	6.4				
					M <sub>N</sub>			3.7	4.3	4.3				
					M <sub>0,max</sub>			5.9	10.1	17.3				
					M <sub>max</sub>			5.9	10.1	17.3				
					n <sub>eto</sub>			4344	3275	2116				
12H15-	10.0	1500	3.8	1.60	M <sub>0</sub>			10.9	11.4	11.4				
					M <sub>N</sub>			10.0	10.0	10.0				
					M <sub>0,max</sub>			15.1	25.8	29.0				
					M <sub>max</sub>			15.1	25.8	29.0				
					n <sub>eto</sub>			1676	1013	918				
12H35-	7.5	3525	5.7	2.80	M <sub>0</sub>				9.8	11.4				
					M <sub>N</sub>				7.5	7.5				
					M <sub>0,max</sub>				13.5	24.1				
					M <sub>max</sub>				13.5	24.1				
					n <sub>eto</sub>				3618	2447				
12L20-	13.5	1950	5.9	2.80	M <sub>0</sub>				15.0	15.0				
					M <sub>N</sub>				13.5	13.5				
					M <sub>0,max</sub>				24.4	41.9				
					M <sub>max</sub>				24.4	41.9				
					n <sub>eto</sub>				1718	1158				
12L41-	11.0	4050	10.2	4.70	M <sub>0</sub>					15.0	15.0	15.0		
					M <sub>N</sub>					11.0	11.0	11.0		
					M <sub>0,max</sub>					22.8	27.0	35.5		
					M <sub>max</sub>					22.8	38.5	49.6		
					n <sub>eto</sub>					4287	2799	2236		

► I... [A], M... [Nm], n... [r/min], P... [kW]

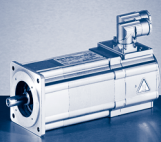

# MCS synchronous servo motors

## EVS9300 servo inverter selection tables

### Mains connection 3 x 400 V and switching frequency 8 kHz

#### Motors without blower

					EVS	9321-E□	9322-E□	9323-E□	9324-E□	9325-E□	9326-E□	9327-E□	9328-E□	9329-E□
					$I_N$	1.5	2.5	3.9	7.0	13.0	23.5	32.0	47.0	59.0
					$I_{0,max}$	2.3	3.8	5.9	10.5	19.5	23.5	32.0	47.0	52.0
MCS	$M_N$	$n_N$	$I_N$	$P_N$	$I_{max}$	2.3	3.8	5.9	10.5	19.5	35.3	48.0	70.5	88.5
14D15-	9.2	1500	4.5	1.45	$M_0$			8.5	11.0	11.0				
					$M_N$			8.0	9.2	9.2				
					$M_{0,max}$			12.1	20.2	29.0				
					$M_{max}$			12.1	20.2	29.0				
					$n_{eto}$			1437	928	676				
14D36-	7.5	3600	7.5	2.80	$M_0$				7.7	11.0	11.0			
					$M_N$				7.0	7.5	7.5			
					$M_{0,max}$				10.9	19.0	22.2			
					$M_{max}$				10.9	19.0	29.0			
					$n_{eto}$				3479	2159	1593			
14H15-	16.0	1500	6.6	2.50	$M_0$				17.3	21.0				
					$M_N$				16.0	16.0				
					$M_{0,max}$				25.4	43.9				
					$M_{max}$				25.4	43.9				
					$n_{eto}$				1247	800				
14H32-	14.0	3225	11.9	4.70	$M_0$					16.2	21.0	21.0		
					$M_N$					14.0	14.0	14.0		
					$M_{0,max}$					23.8	28.2	37.1		
					$M_{max}$					23.8	40.2	51.9		
					$n_{eto}$					2875	1817	1471		
14L15-	23.0	1500	9.7	3.60	$M_0$					28.0	28.0			
					$M_N$					23.0	23.0			
					$M_{0,max}$					45.0	52.9			
					$M_{max}$					45.0	73.8			
					$n_{eto}$					1126	788			
14L32-	17.2	3225	15.0	5.80	$M_0$					15.2	27.4	28.0	28.0	
					$M_N$					14.9	17.2	17.2	17.2	
					$M_{0,max}$					23.5	28.3	37.6	52.9	
					$M_{max}$					23.5	41.0	53.9	73.9	
					$n_{eto}$					3953	2608	2096	1672	
14P14-	30.0	1350	10.8	4.20	$M_0$					37.0	37.0	37.0		
					$M_N$					30.0	30.0	30.0		
					$M_{0,max}$					52.5	61.8	80.0		
					$M_{max}$					52.5	86.3	105.1		
					$n_{eto}$					998	668	573		
14P32-	21.0	3225	15.6	7.10	$M_0$					19.8	35.8	37.0	37.0	
					$M_N$					17.5	21.0	21.0	21.0	
					$M_{0,max}$					27.4	33.0	43.9	61.8	
					$M_{max}$					27.4	47.9	63.0	86.4	
					$n_{eto}$					3300	2299	1829	1404	
19F14-	27.0	1425	8.6	4.00	$M_0$				22.6	32.0	32.0			
					$M_N$				22.0	27.0	27.0			
					$M_{0,max}$				33.0	58.2	68.3			
					$M_{max}$				33.0	58.2	86.0			
					$n_{eto}$				1459	1056	746			
19F30-	21.0	3000	14.0	6.60	$M_0$					21.0	32.0	32.0		
					$M_N$					19.5	21.0	21.0		
					$M_{0,max}$					29.2	35.2	47.2		
					$M_{max}$					29.2	51.5	68.3		
					$n_{eto}$					3352	2573	2033		

►  $I...$  [A],  $M...$  [Nm],  $n...$  [r/min],  $P...$  [kW]

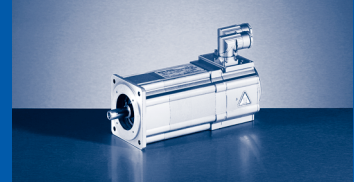

### Mains connection 3 x 400 V and switching frequency 8 kHz

#### Motors without blower

					EVS	9321-E□	9322-E□	9323-E□	9324-E□	9325-E□	9326-E□	9327-E□	9328-E□	9329-E□
					$I_N$	1.5	2.5	3.9	7.0	13.0	23.5	32.0	47.0	59.0
					$I_{0,max}$	2.3	3.8	5.9	10.5	19.5	23.5	32.0	47.0	52.0
MCS	$M_N$	$n_N$	$I_N$	$P_N$	$I_{max}$	2.3	3.8	5.9	10.5	19.5	35.3	48.0	70.5	88.5
19J14-	40.0	1425	12.3	6.00	$M_0$					43.6	51.0	51.0		
					$M_N$					40.0	40.0	40.0		
					$M_{0,max}$					60.8	72.4	96.0		
					$M_{max}$					60.8	104.5	129.0		
					$n_{eto}$					1376	996	839		
19J30-	29.0	3000	18.5	9.10	$M_0$						39.3	51.0	51.0	51.0
					$M_N$					29.0	29.0	29.0	29.0	29.0
					$M_{0,max}$					36.8	50.2	72.4	79.5	79.5
					$M_{max}$					55.2	73.8	104.7	127.6	127.6
					$n_{eto}$					3150	2850	2162	1817	1817
19P14-	51.0	1350	14.3	7.20	$M_0$					47.5	64.0	64.0		
					$M_N$					46.4	51.0	51.0		
					$M_{0,max}$					69.5	79.6	106.7		
					$M_{max}$					69.5	116.7	155.5		
					$n_{eto}$					1400	1187	996		
19P30-	32.0	3000	19.0	10.00	$M_0$						43.1	58.7	64.0	64.0
					$M_N$						32.0	32.0	32.0	32.0
					$M_{0,max}$						39.6	53.9	79.6	87.6
					$M_{max}$						59.3	81.2	116.9	144.3
					$n_{eto}$						3000	2938	2638	2298

►  $I...$  [A],  $M...$  [Nm],  $n...$  [r/min],  $P...$  [kW]

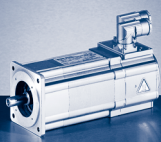

# MCS synchronous servo motors

## EVS9300 servo inverter selection tables

### Mains connection 3 x 400 V and switching frequency 8 kHz

#### Motors with blower

					EVS	9322-E□	9323-E□	9324-E□	9325-E□	9326-E□	9327-E□	9328-E□	9329-E□
					$I_N$	2.5	3.9	7.0	13.0	23.5	32.0	47.0	59.0
					$I_{0,max}$	3.8	5.9	10.5	19.5	23.5	32.0	47.0	52.0
MCS	$M_N$	$n_N$	$I_N$	$P_N$	$I_{max}$	3.8	5.9	10.5	19.5	35.3	48.0	70.5	88.5
12D17-	7.0	1650	3.0	1.20	$M_0$	5.9	7.5	7.5					
					$M_N$	5.3	7.0	7.0					
					$M_{0,max}$	7.6	11.6	17.7					
					$M_{max}$	7.6	11.6	17.7					
					$n_{eto}$	1790	1358	919					
12D35-	6.0	3525	5.6	2.20	$M_0$		4.6	7.5	7.5				
					$M_N$		3.7	6.0	6.0				
					$M_{0,max}$		5.9	10.1	17.3				
					$M_{max}$		5.9	10.1	17.3				
					$n_{eto}$		4344	3275	2116				
12H14-	12.0	1350	4.1	1.70	$M_0$		10.9	12.8	12.8				
					$M_N$		10.3	12.0	12.0				
					$M_{0,max}$		15.1	25.8	29.0				
					$M_{max}$		15.1	25.8	29.0				
					$n_{eto}$		1676	1013	918				
12H34-	10.5	3375	7.5	3.70	$M_0$			9.8	12.8				
					$M_N$			9.6	10.5				
					$M_{0,max}$			13.5	24.1				
					$M_{max}$			13.5	24.1				
					$n_{eto}$			3618	2447				
12L17-	17.0	1650	6.7	2.90	$M_0$			18.5	19.0				
					$M_N$			17.0	17.0				
					$M_{0,max}$			24.4	41.9				
					$M_{max}$			24.4	41.9				
					$n_{eto}$			1718	1158				
12L39-	14.0	3900	11.7	5.70	$M_0$				17.2	19.0	19.0		
					$M_N$				14.0	14.0	14.0		
					$M_{0,max}$				22.8	27.0	35.5		
					$M_{max}$				22.8	38.5	49.6		
					$n_{eto}$				4287	2799	2236		
14D14-	12.0	1350	5.4	1.70	$M_0$		8.5	12.5	12.5				
					$M_N$		8.0	12.0	12.0				
					$M_{0,max}$		12.1	20.2	29.0				
					$M_{max}$		12.1	20.2	29.0				
					$n_{eto}$		1437	928	676				
14D30-	10.5	3000	9.7	3.30	$M_0$			7.7	12.5	12.5			
					$M_N$			7.0	10.0	10.0			
					$M_{0,max}$			10.9	19.0	22.2			
					$M_{max}$			10.9	19.0	29.0			
					$n_{eto}$			3479	2159	1593			
14H12-	23.5	1200	8.3	3.00	$M_0$			17.3	25.5				
					$M_N$			17.2	23.5				
					$M_{0,max}$			25.4	43.9				
					$M_{max}$			25.4	43.9				
					$n_{eto}$			1247	800				
14H28-	20.5	2775	15.0	6.00	$M_0$				16.2	25.5	25.5		
					$M_N$				16.1	20.5	20.5		
					$M_{0,max}$				23.8	28.2	37.1		
					$M_{max}$				23.8	40.2	51.9		
					$n_{eto}$				2875	1817	1471		

►  $I...$  [A],  $M...$  [Nm],  $n...$  [r/min],  $P...$  [kW]

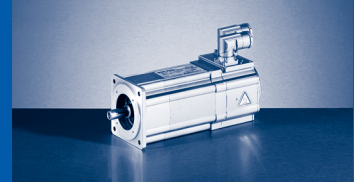

### Mains connection 3 x 400 V and switching frequency 8 kHz

#### Motors with blower

					EVS	9322-E□	9323-E□	9324-E□	9325-E□	9326-E□	9327-E□	9328-E□	9329-E□	
					$I_N$	2.5	3.9	7.0	13.0	23.5	32.0	47.0	59.0	
					$I_{0,max}$	3.8	5.9	10.5	19.5	23.5	32.0	47.0	52.0	
MCS	$M_N$	$n_N$	$I_N$	$P_N$	$I_{max}$	3.8	5.9	10.5	19.5	35.3	48.0	70.5	88.5	
14L14-	30.5	1350	11.8	4.30	$M_0$				33.4	34.5				
					$M_N$			30.5	30.5					
					$M_{0,max}$			45.0	52.9					
					$M_{max}$			45.0	73.8					
					$n_{eto}$			1126	788					
14L30-	25.5	3000	20.8	8.00	$M_0$					27.4	34.5	34.5		
					$M_N$				25.5	25.5	25.5			
					$M_{0,max}$				28.3	37.6	52.9			
					$M_{max}$				41.0	53.9	73.9			
					$n_{eto}$				2608	2096	1672			
14P11-	42.0	1050	13.4	4.60	$M_0$				40.1	43.5	43.5			
					$M_N$				40.0	42.0	42.0			
					$M_{0,max}$				52.5	61.8	80.0			
					$M_{max}$				52.5	86.3	105.1			
					$n_{eto}$				998	668	573			
14P26-	33.0	2625	21.9	9.10	$M_0$					35.8	43.5	43.5		
					$M_N$				33.0	33.0	33.0			
					$M_{0,max}$				33.0	43.9	61.8			
					$M_{max}$				47.9	63.0	86.4			
					$n_{eto}$				2299	1829	1404			
19F12-	38.0	1200	11.3	4.80	$M_0$			22.6	41.5	41.5				
					$M_N$				22.0	38.0	38.0			
					$M_{0,max}$				33.0	58.2	68.3			
					$M_{max}$				33.0	58.2	86.0			
					$n_{eto}$				1459	1056	746			
19F29-	32.5	2850	20.1	9.70	$M_0$					39.9	41.5			
					$M_N$					32.5	32.5			
					$M_{0,max}$					35.2	47.2			
					$M_{max}$					51.5	68.3			
					$n_{eto}$					2573	2033			
19J12-	62.5	1200	18.3	7.90	$M_0$				43.6	70.5	70.5			
					$M_N$				43.4	62.5	62.5			
					$M_{0,max}$				60.8	72.4	96.0			
					$M_{max}$				60.8	104.5	129.0			
					$n_{eto}$				1376	996	839			
19J29-	50.5	2850	31.0	15.10	$M_0$						55.5	70.5	70.5	
					$M_N$					50.5	50.5	50.5		
					$M_{0,max}$					50.2	72.4	79.5		
					$M_{max}$					73.8	104.7	127.6		
					$n_{eto}$					2850	2162	1817		
19P12-	72.0	1200	21.3	9.00	$M_0$				47.5	86.0	86.0			
					$M_N$				46.4	72.0	72.0			
					$M_{0,max}$				69.5	79.6	106.7			
					$M_{max}$				69.5	116.7	155.5			
					$n_{eto}$				1400	1187	996			
19P29-	53.0	2850	29.5	15.80	$M_0$						58.7	86.0	86.0	
					$M_N$					53.0	53.0	53.0		
					$M_{0,max}$					53.9	79.6	87.6		
					$M_{max}$					81.2	116.9	144.3		
					$n_{eto}$					2938	2638	2298		

►  $I...$  [A],  $M...$  [Nm],  $n...$  [r/min],  $P...$  [kW]

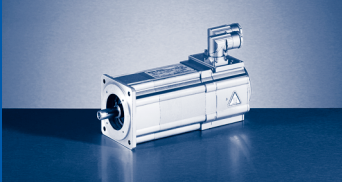

# MCS synchronous servo motors

## Torque characteristics

Mains connection 3x 400 V

### MCS06C41

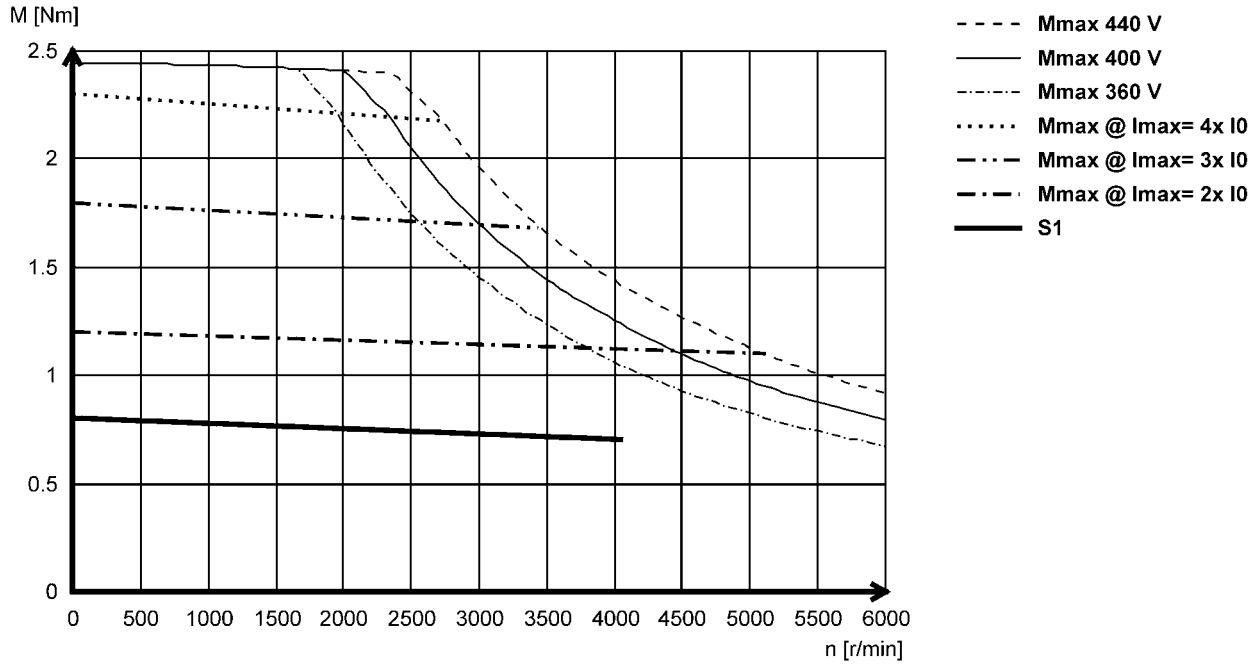

### MCS06C60

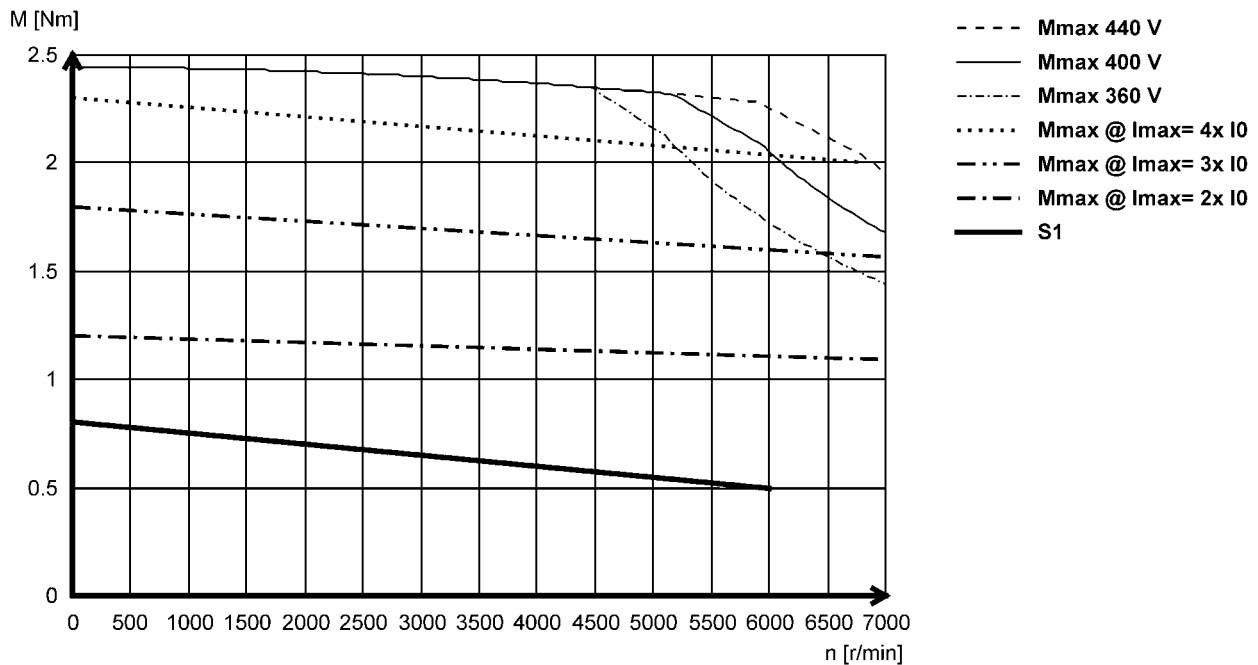

► Other torque characteristics with Lenze inverters can be found at [www.lenze.de/dsc](http://www.lenze.de/dsc).

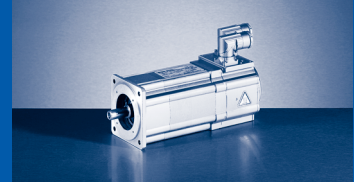

Mains connection 3x 400 V

### MCS06F41

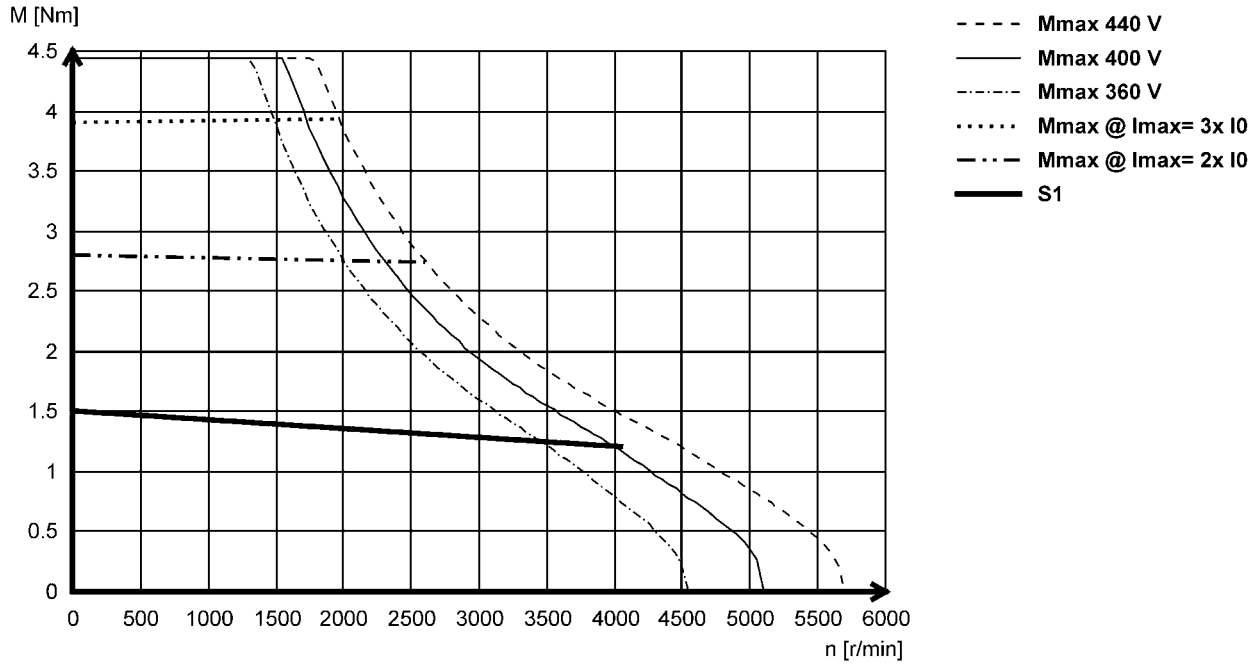

### MCS06F60

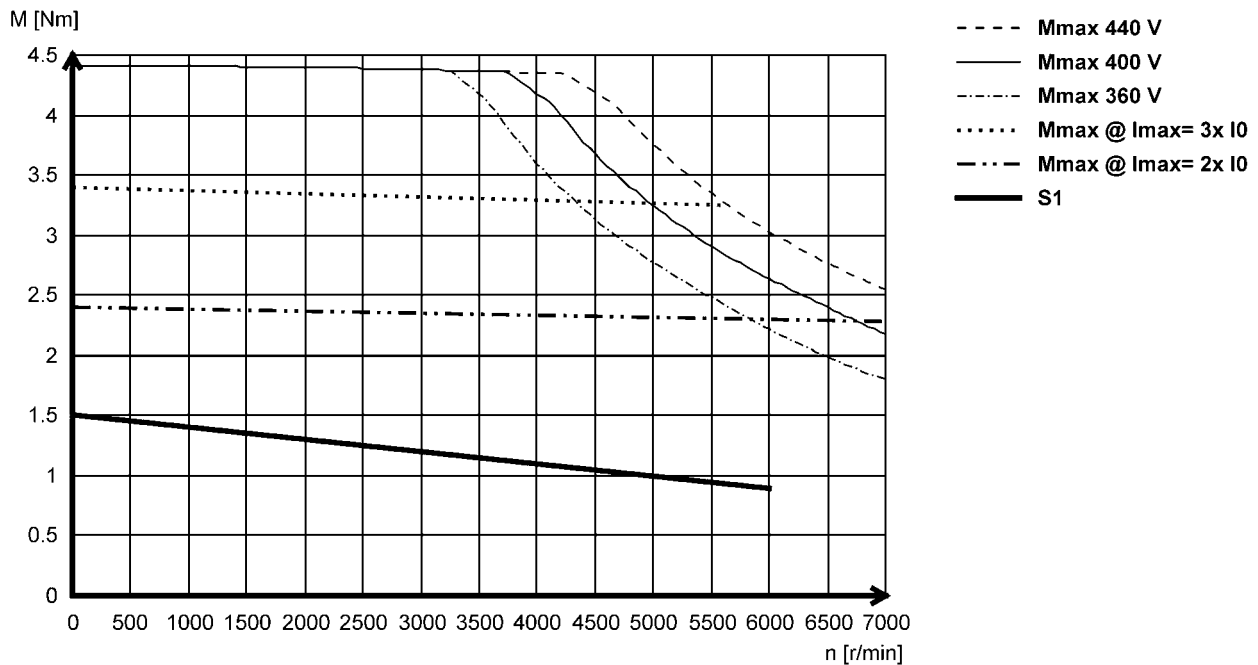

► Other torque characteristics with Lenze inverters can be found at [www.lenze.de/dsc](http://www.lenze.de/dsc).

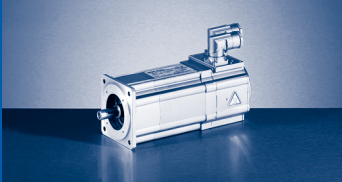

# MCS synchronous servo motors

## Torque characteristics

Mains connection 3x 400 V

### MCS06I41

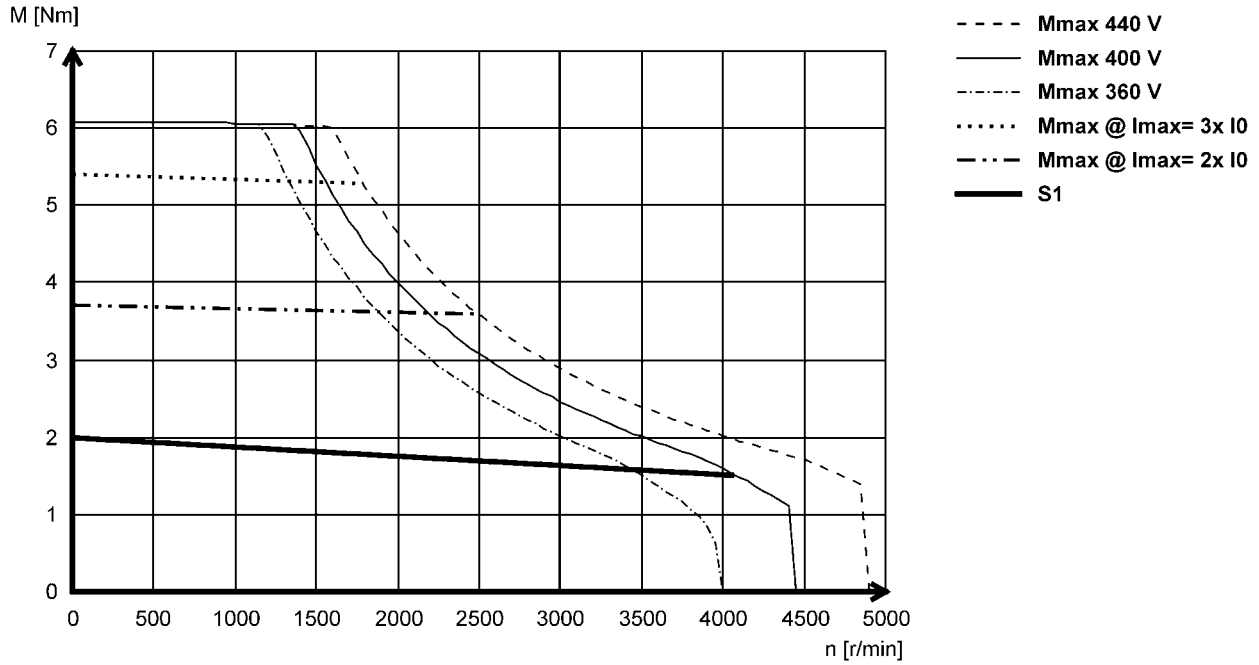

### MCS06I60

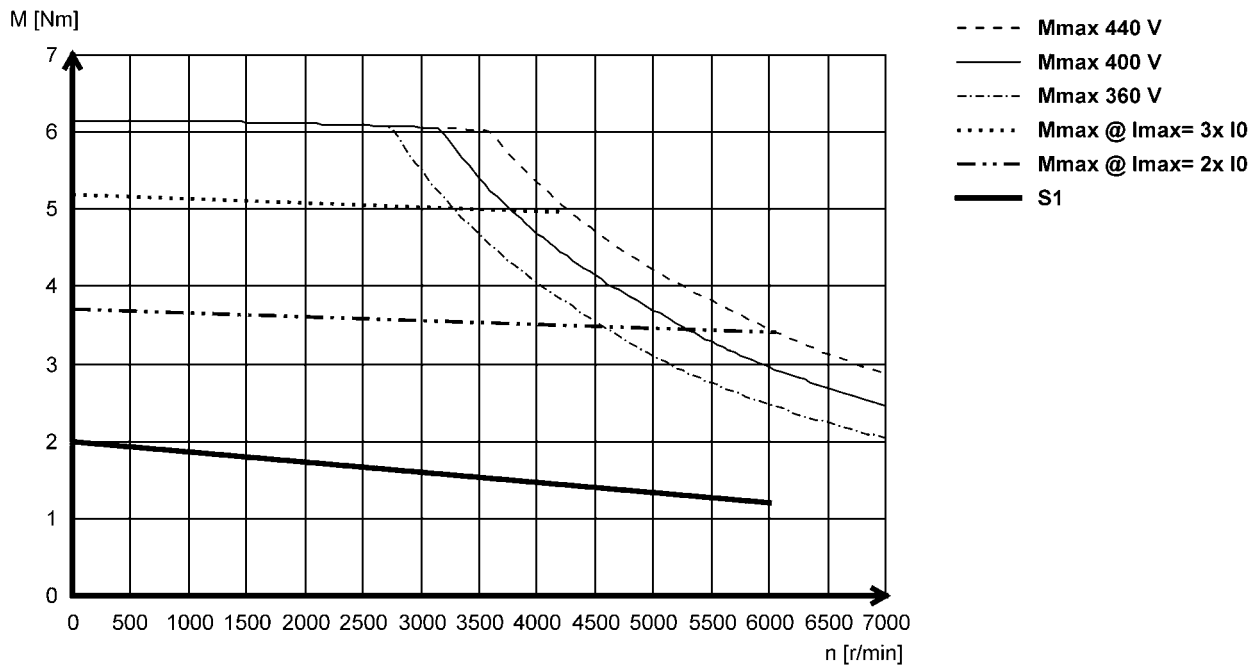

► Other torque characteristics with Lenze inverters can be found at [www.lenze.de/dsc](http://www.lenze.de/dsc).



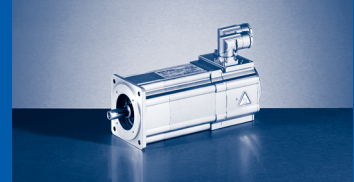

Mains connection 3x 400 V

### MCS09D41

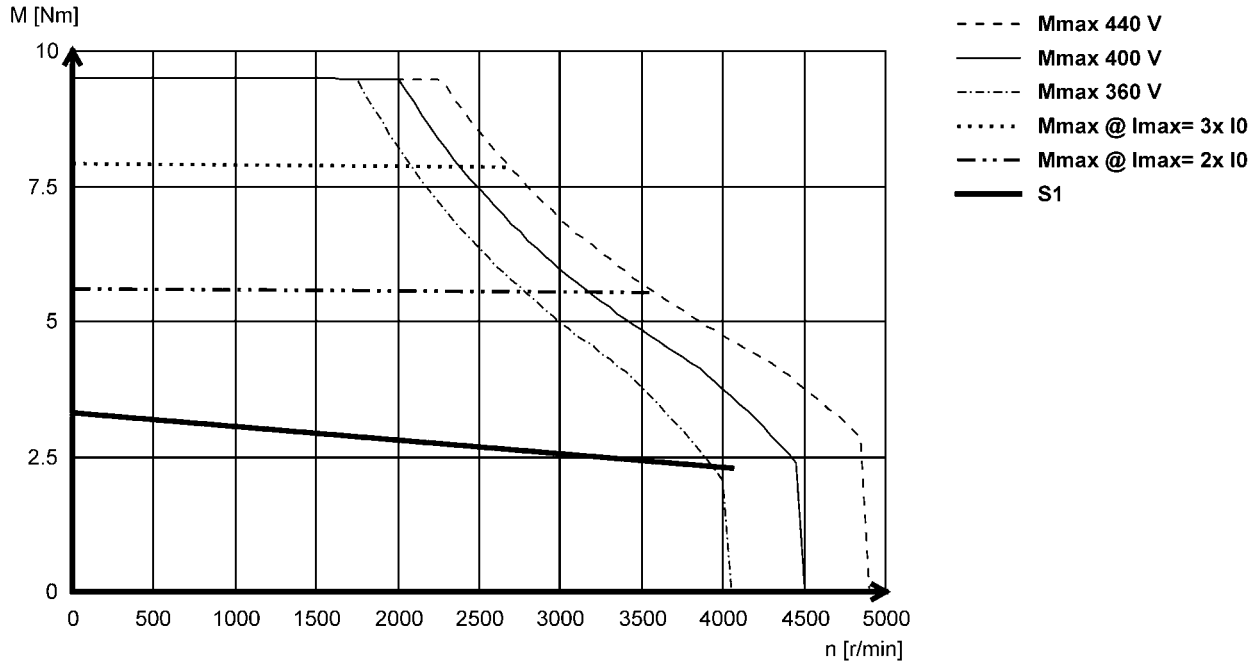

### MCS09D60

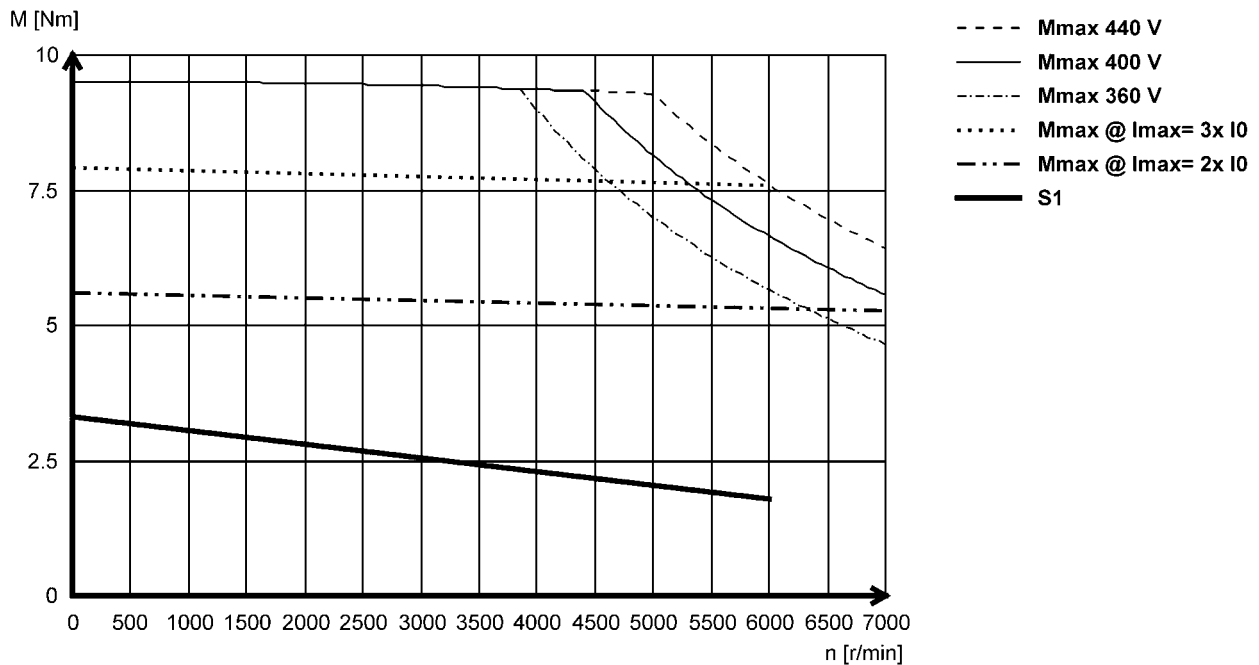

► Other torque characteristics with Lenze inverters can be found at [www.lenze.de/dsc](http://www.lenze.de/dsc).

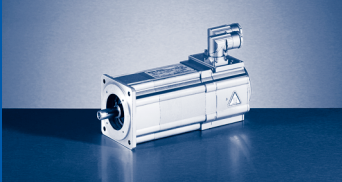

# MCS synchronous servo motors

## Torque characteristics

Mains connection 3x 400 V

### MCS09F38

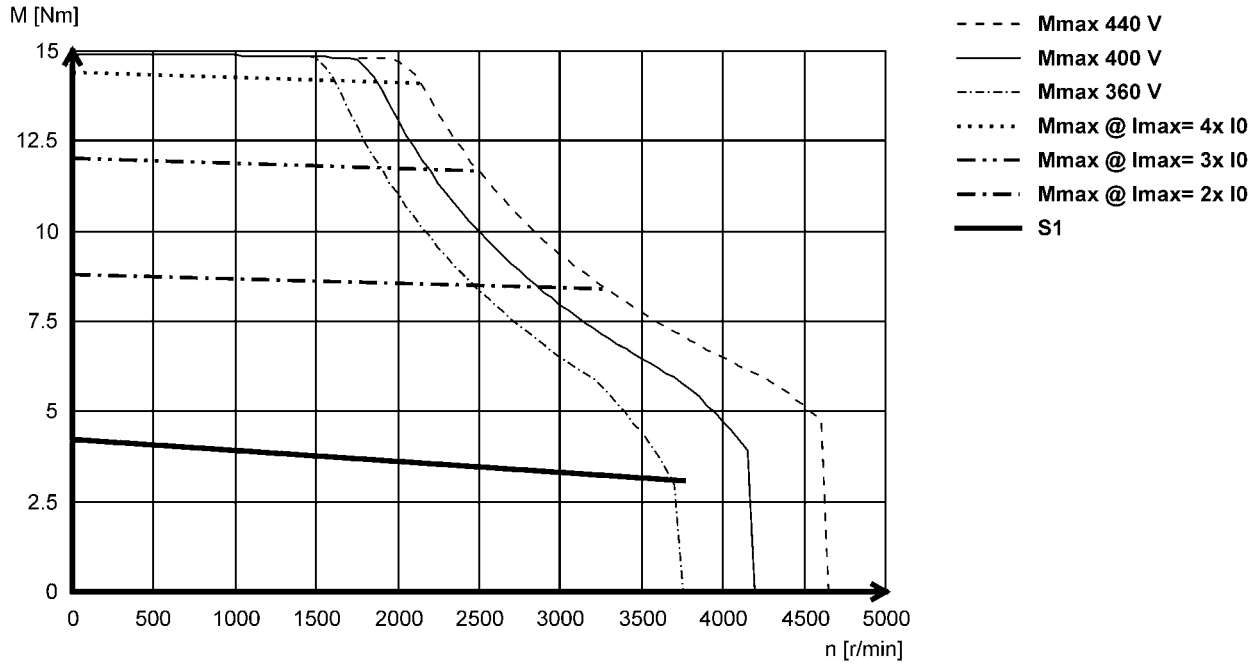

### MCS09F60

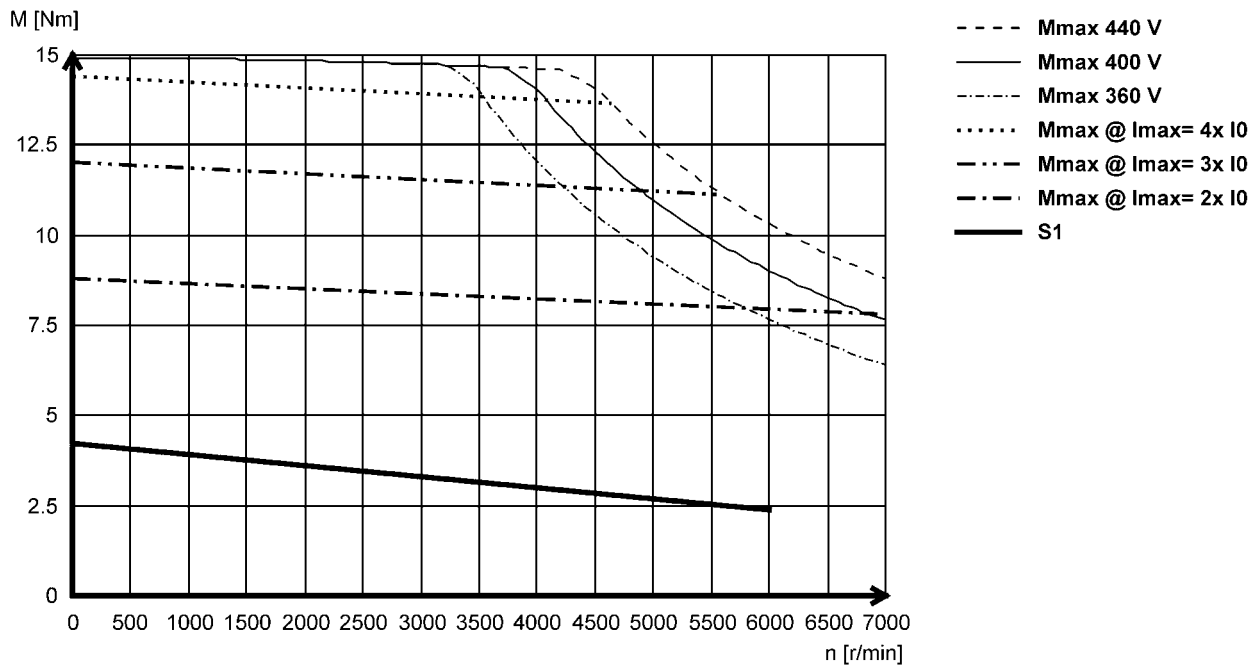

► Other torque characteristics with Lenze inverters can be found at [www.lenze.de/dsc](http://www.lenze.de/dsc).

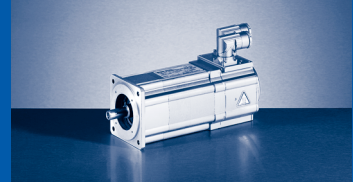

### Mains connection 3x 400 V

#### MCS09H41

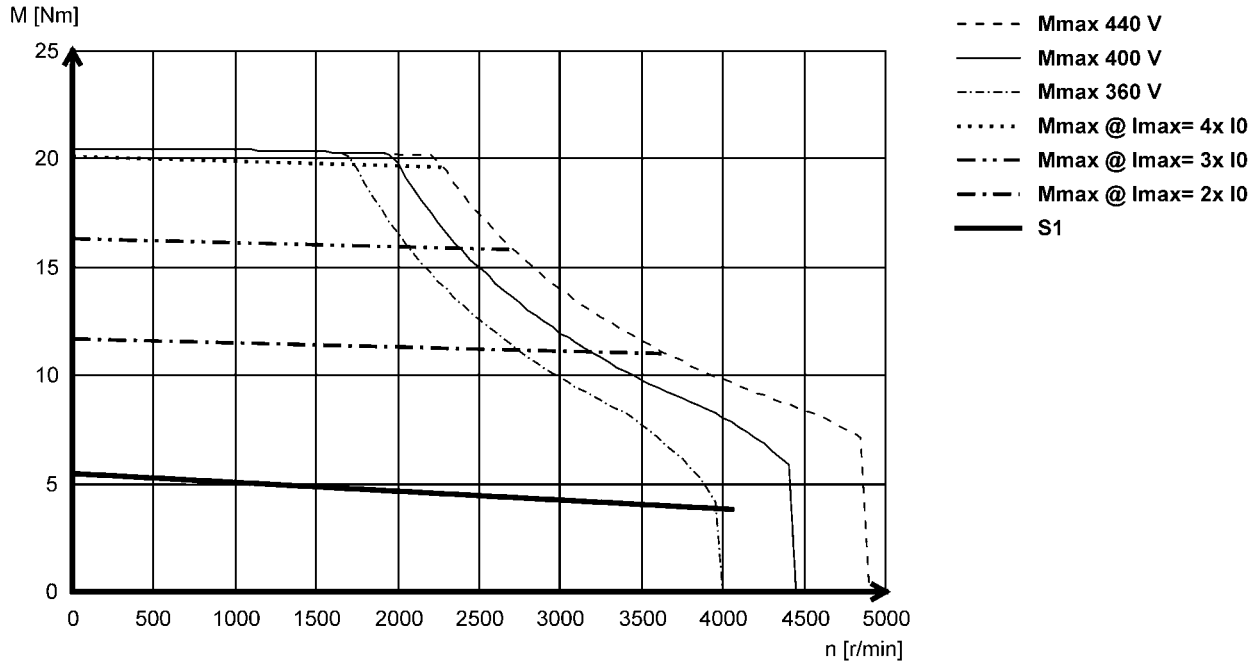

#### MCS09H60

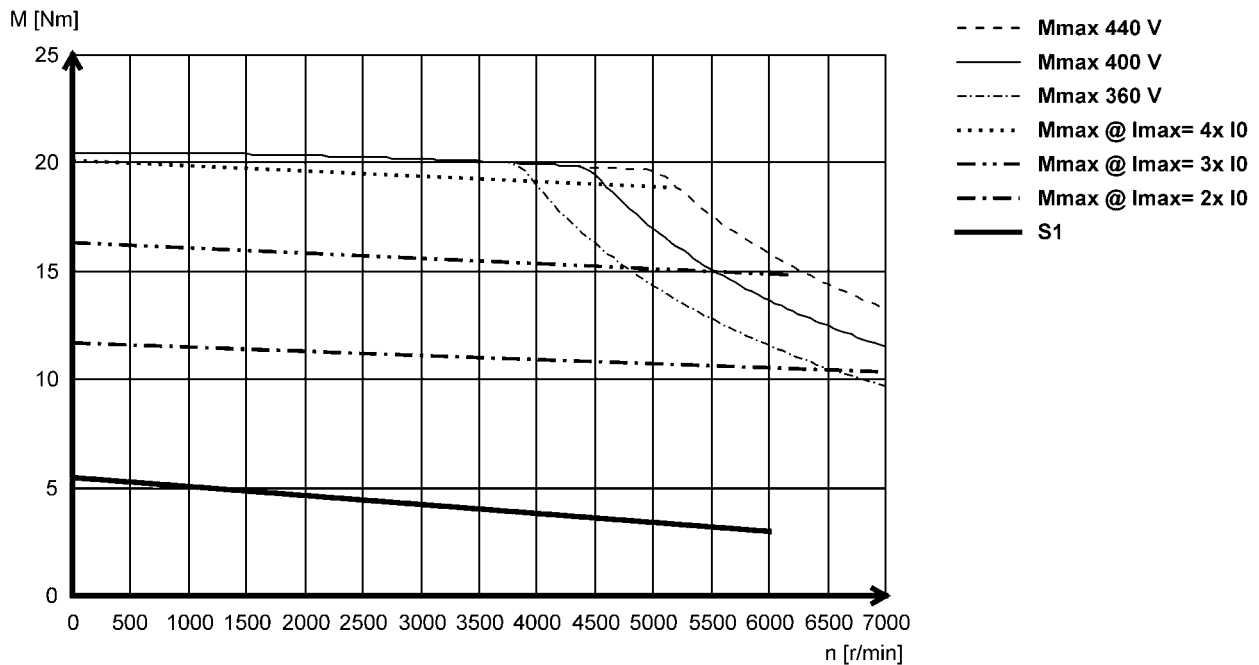

► Other torque characteristics with Lenze inverters can be found at [www.lenze.de/dsc](http://www.lenze.de/dsc).

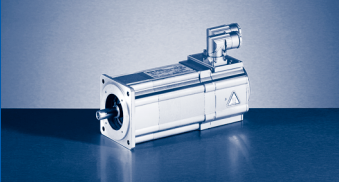

# MCS synchronous servo motors

## Torque characteristics

Mains connection 3x 400 V

### MCS09L41

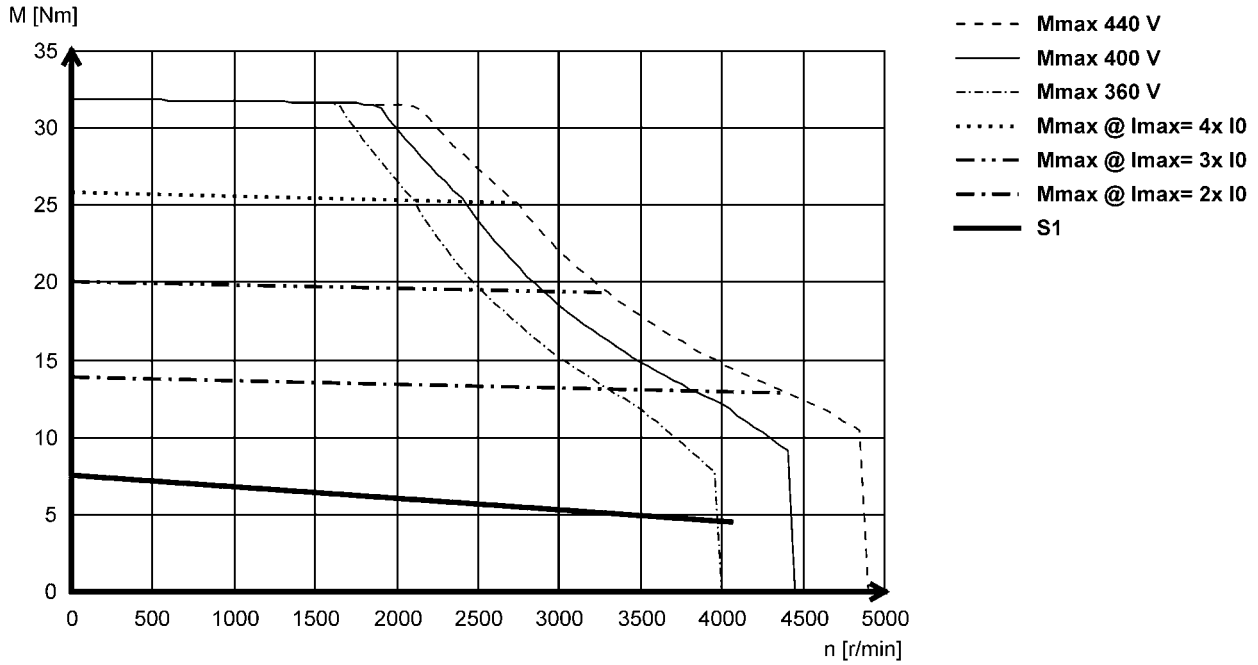

### MCS09L51

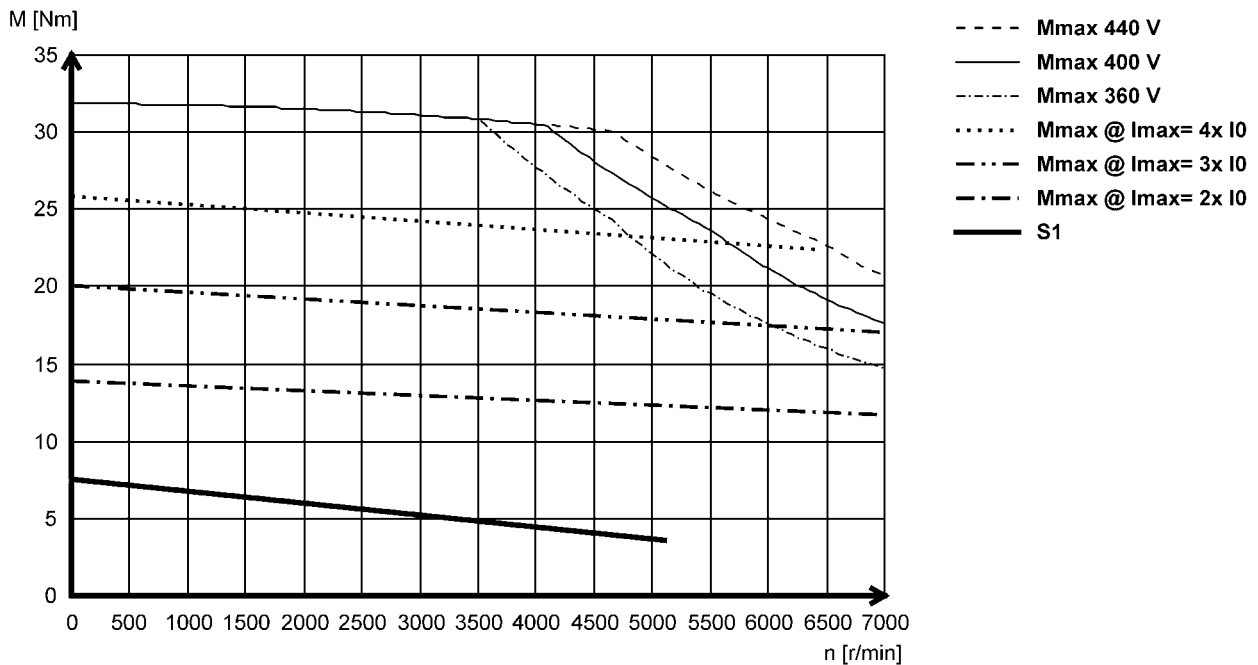

► Other torque characteristics with Lenze inverters can be found at [www.lenze.de/dsc](http://www.lenze.de/dsc).

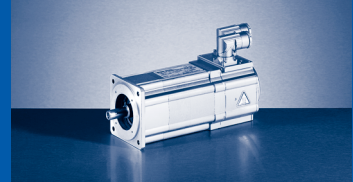

### Mains connection 3x 400 V

#### MCS12D17

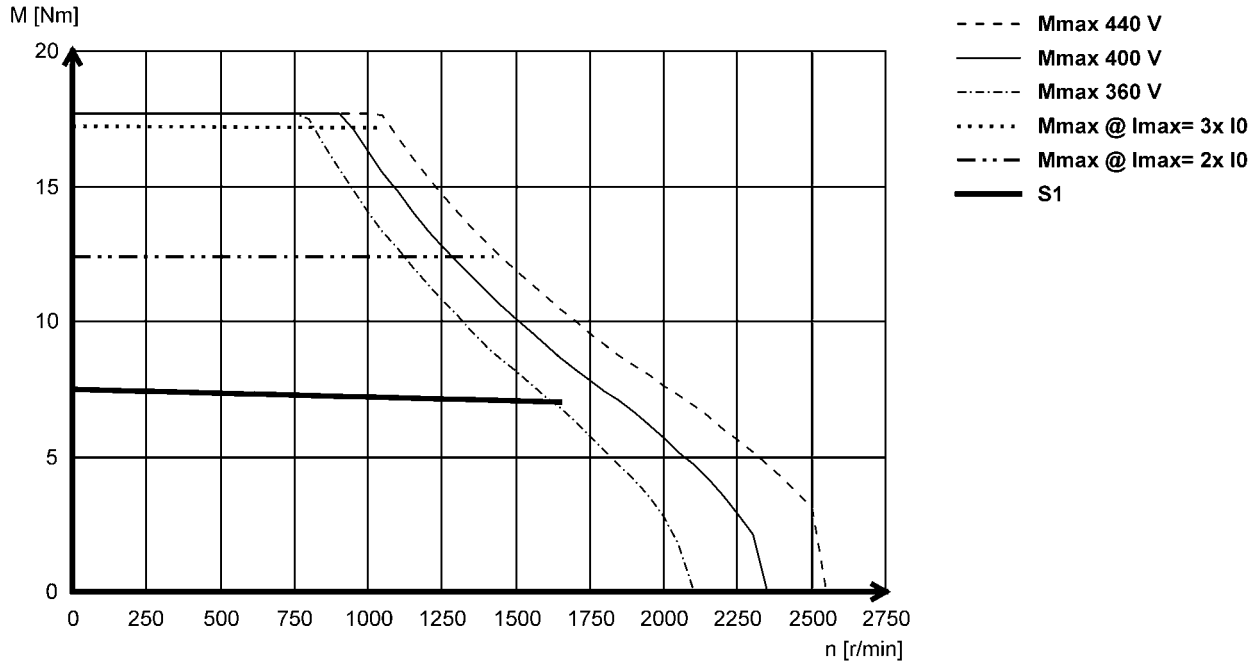

#### MCS12D20

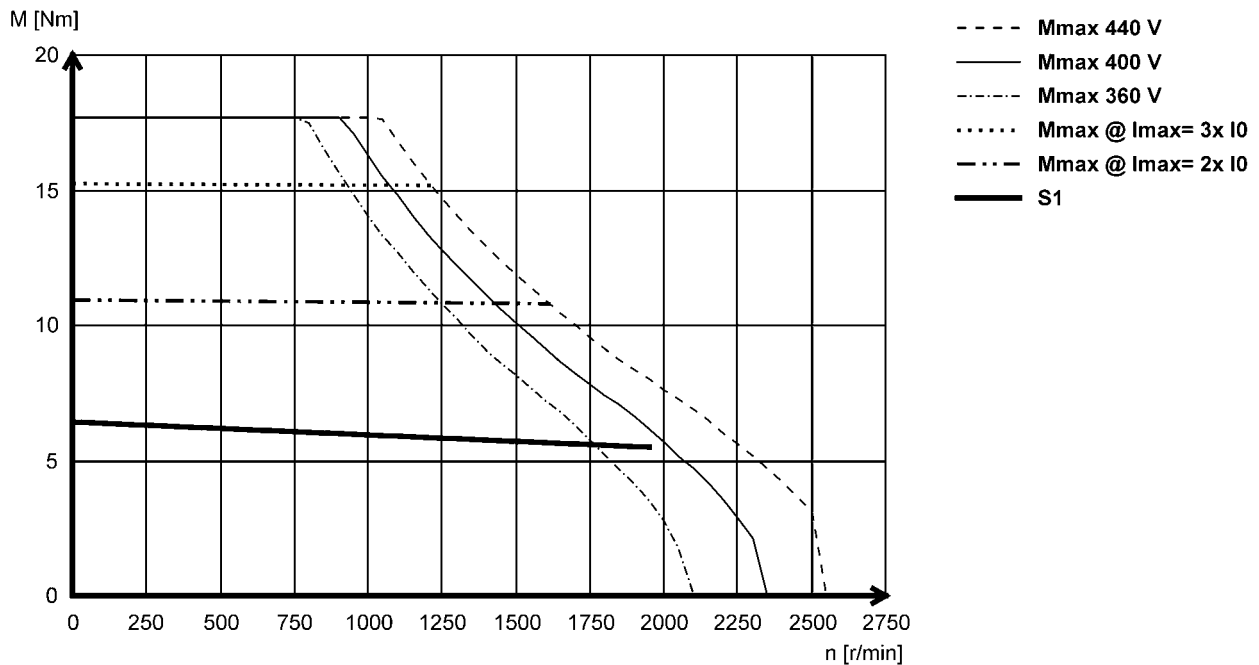

► Other torque characteristics with Lenze inverters can be found at [www.lenze.de/dsc](http://www.lenze.de/dsc).

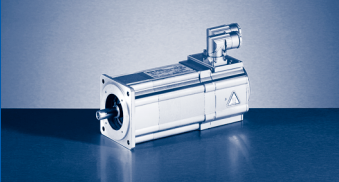

# MCS synchronous servo motors

## Torque characteristics

Mains connection 3x 400 V

### MCS12D35

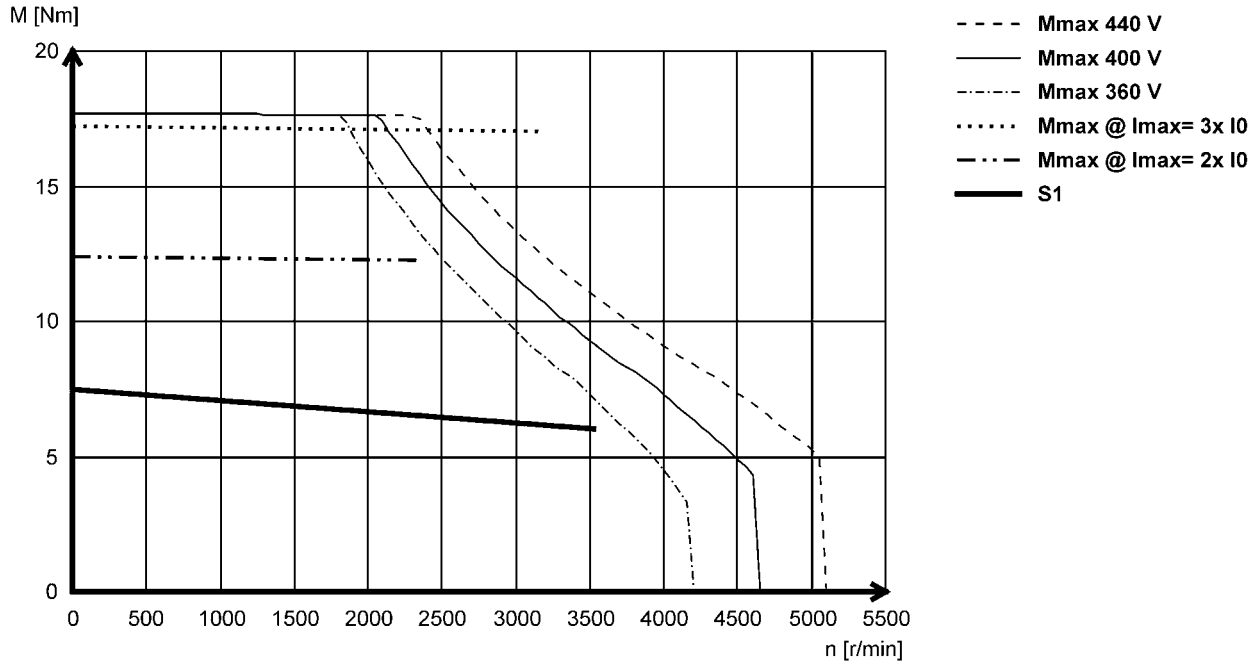

### MCS12D41

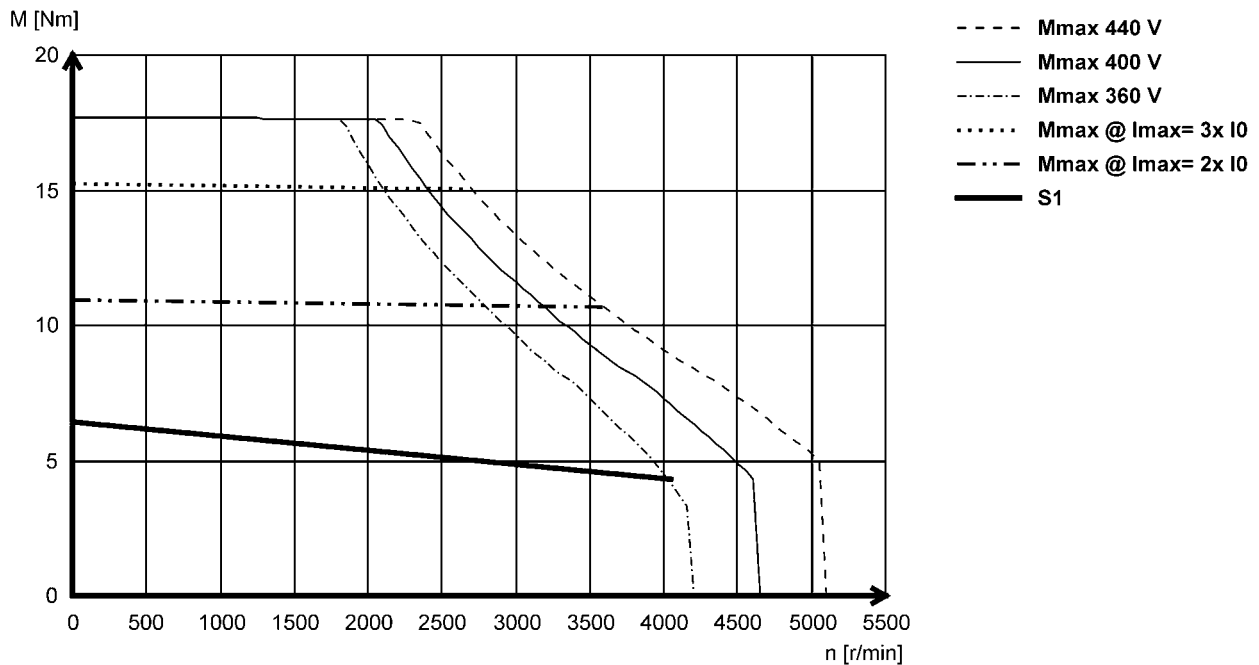

► Other torque characteristics with Lenze inverters can be found at [www.lenze.de/dsc](http://www.lenze.de/dsc).

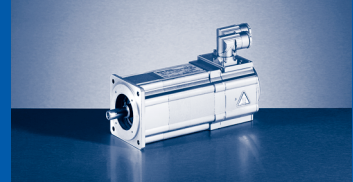

Mains connection 3x 400 V

### MCS12H14

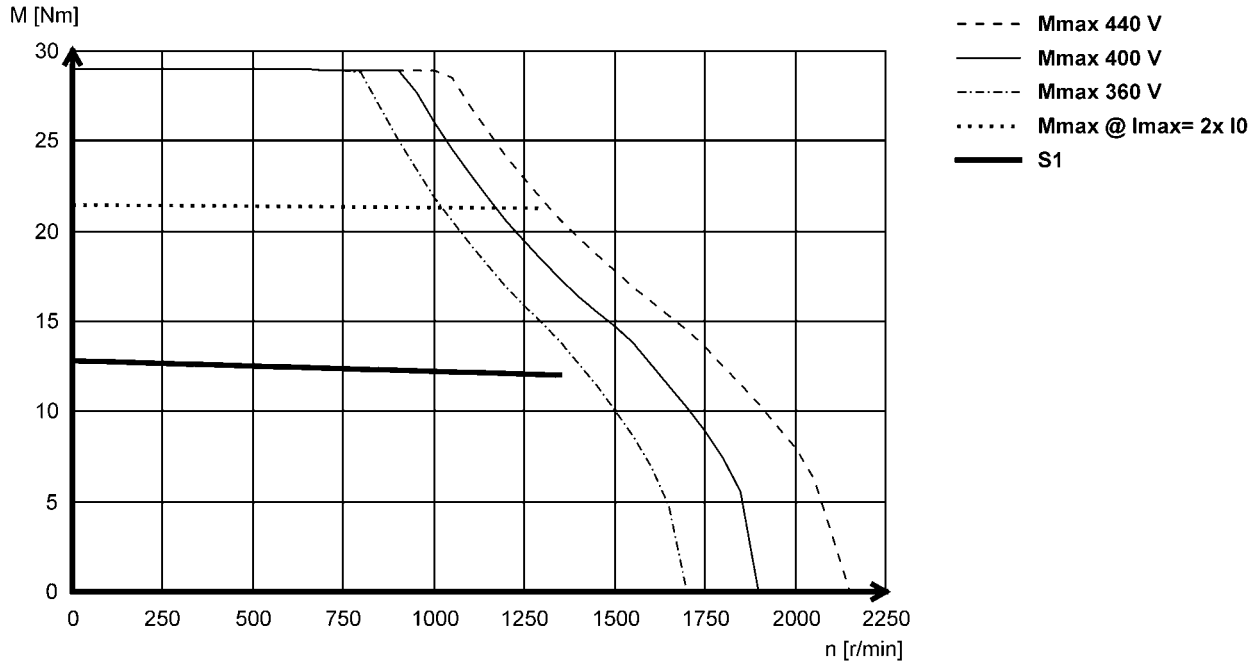

### MCS12H15

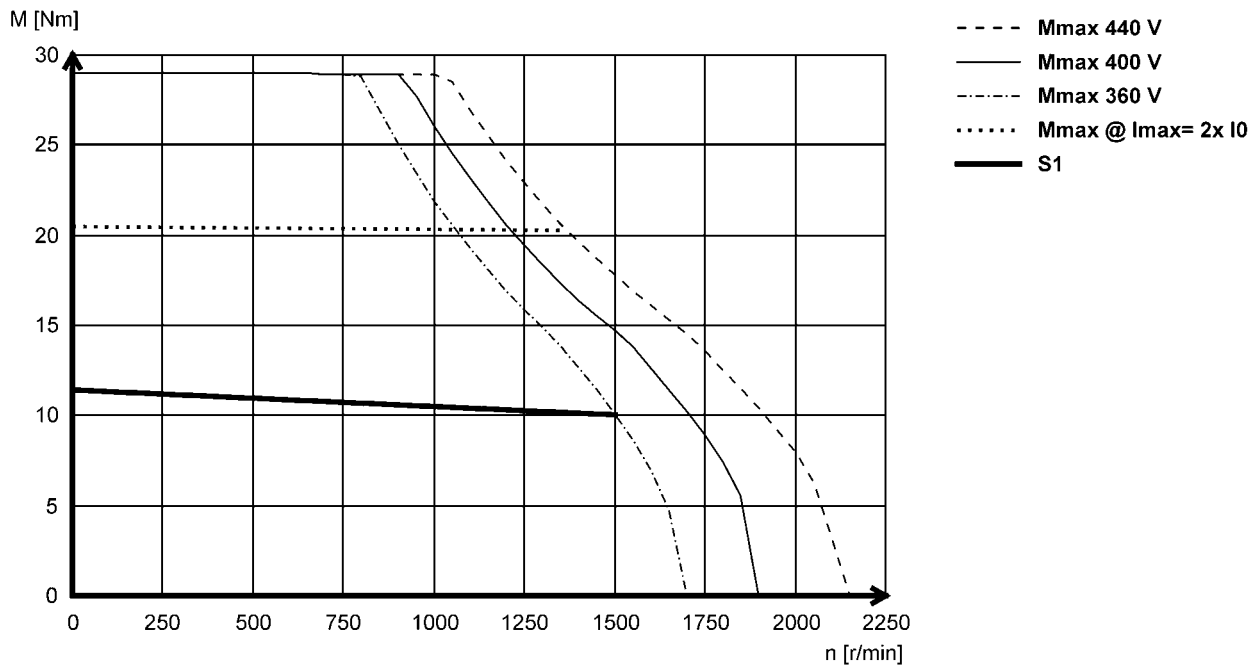

► Other torque characteristics with Lenze inverters can be found at [www.lenze.de/dsc](http://www.lenze.de/dsc).

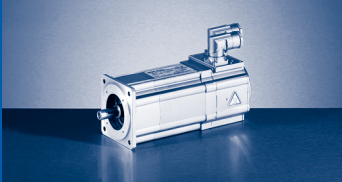

# MCS synchronous servo motors

## Torque characteristics

Mains connection 3x 400 V

### MCS12H34

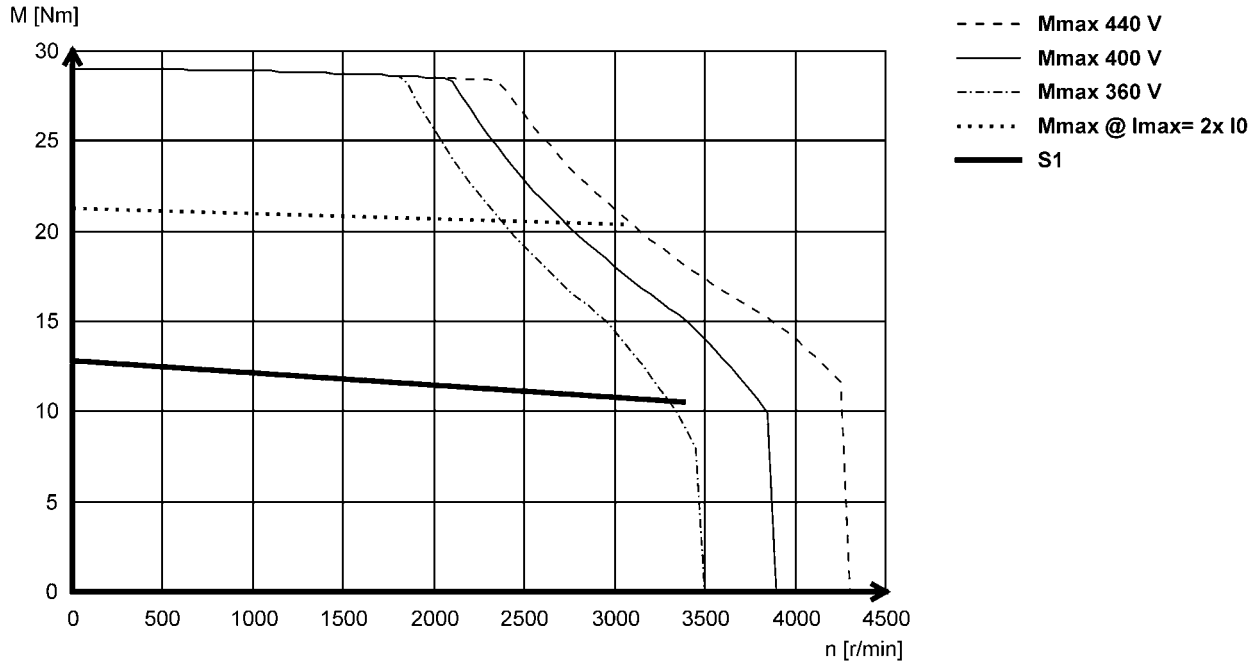

### MCS12H35

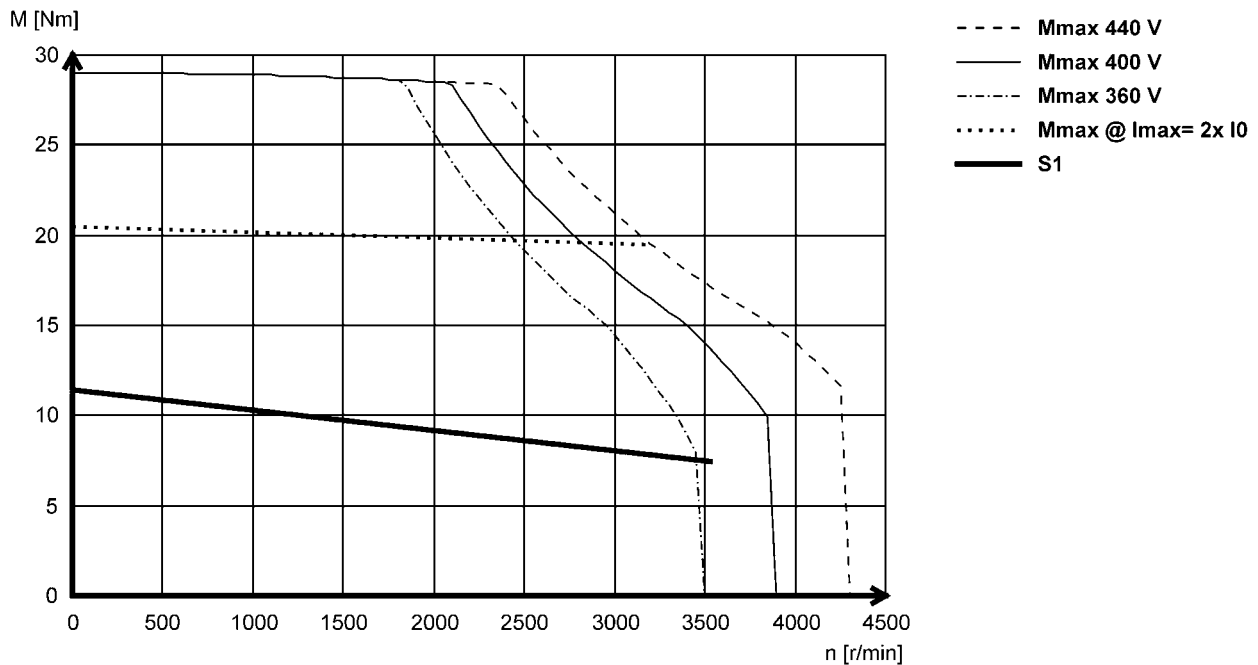

► Other torque characteristics with Lenze inverters can be found at [www.lenze.de/dsc](http://www.lenze.de/dsc).



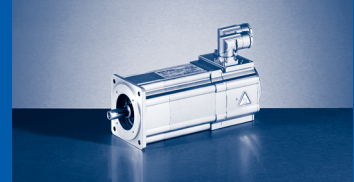

Mains connection 3x 400 V

### MCS12L17

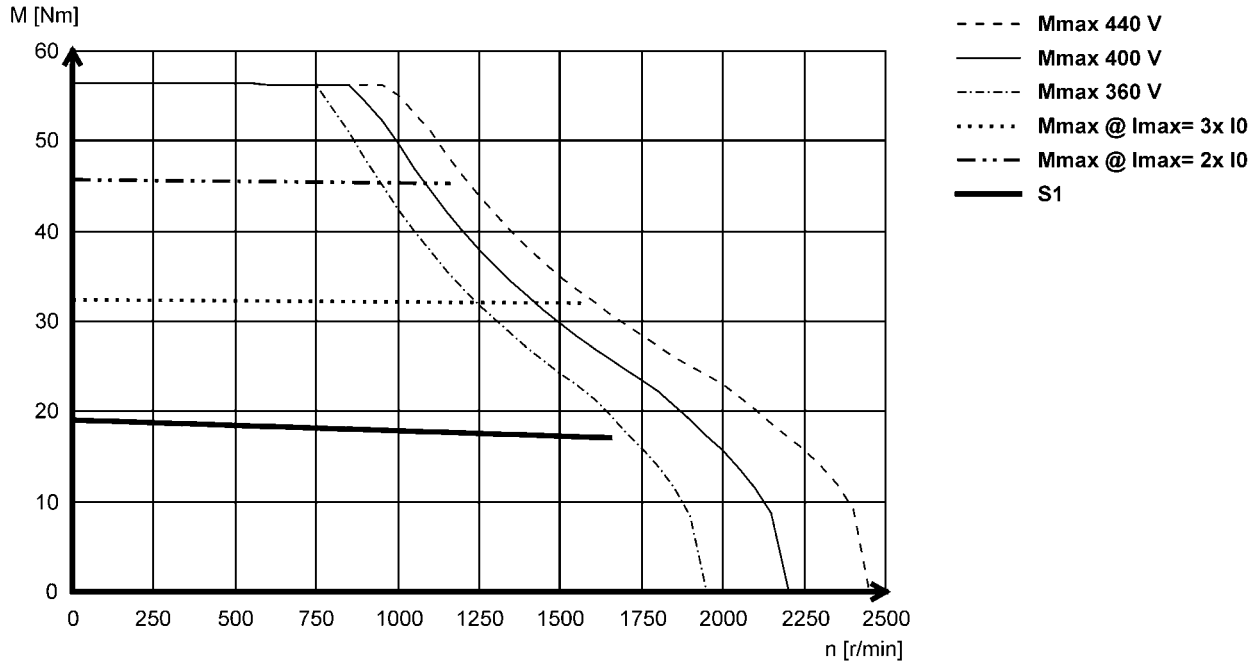

### MCS12L20

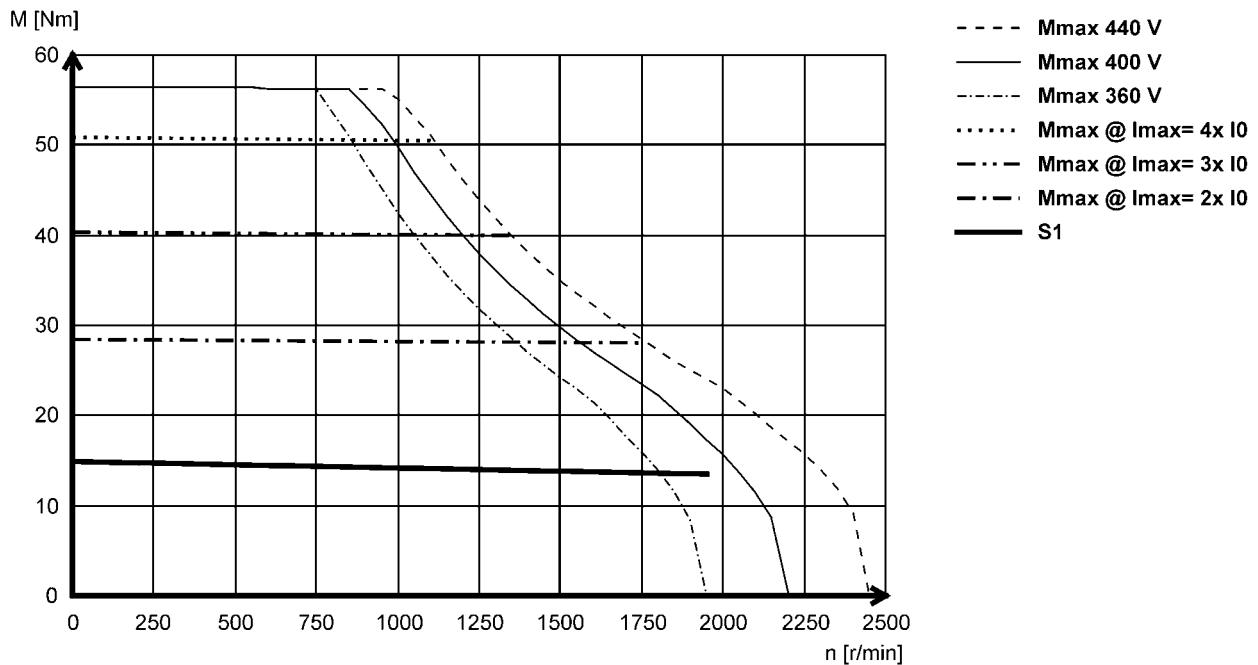

► Other torque characteristics with Lenze inverters can be found at [www.lenze.de/dsc](http://www.lenze.de/dsc).

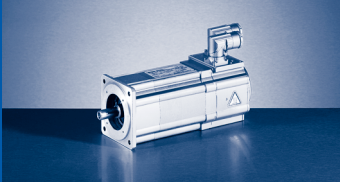

# MCS synchronous servo motors

## Torque characteristics

Mains connection 3x 400 V

### MCS12L39

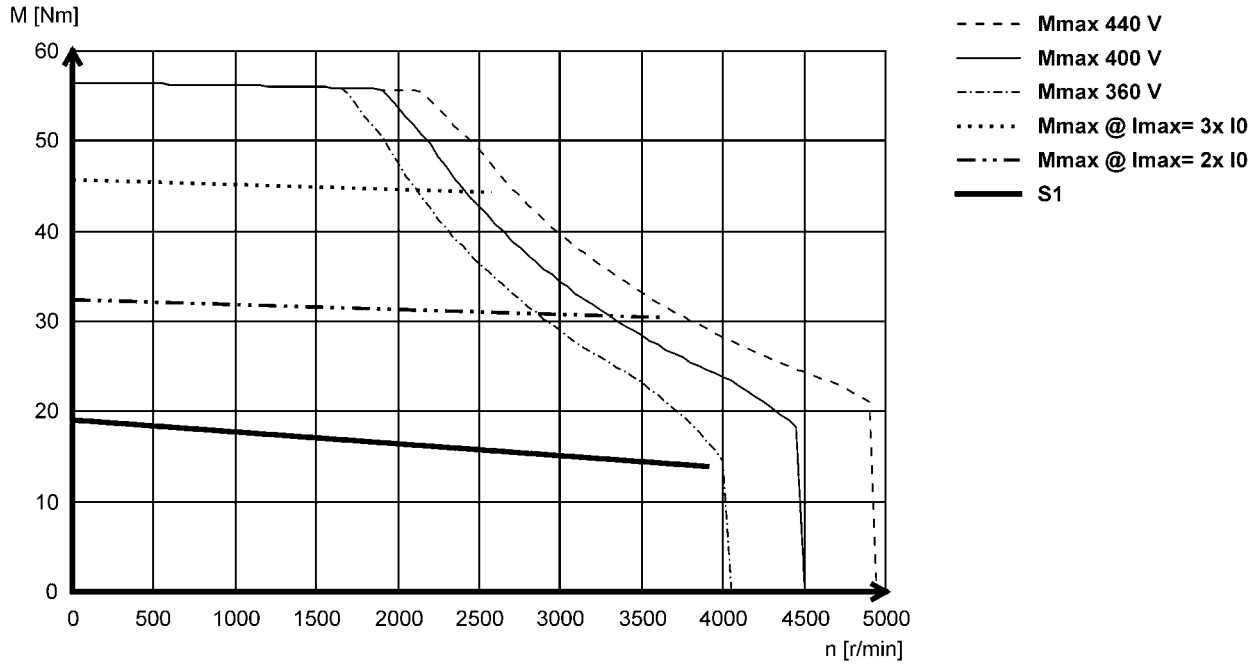

### MCS12L41

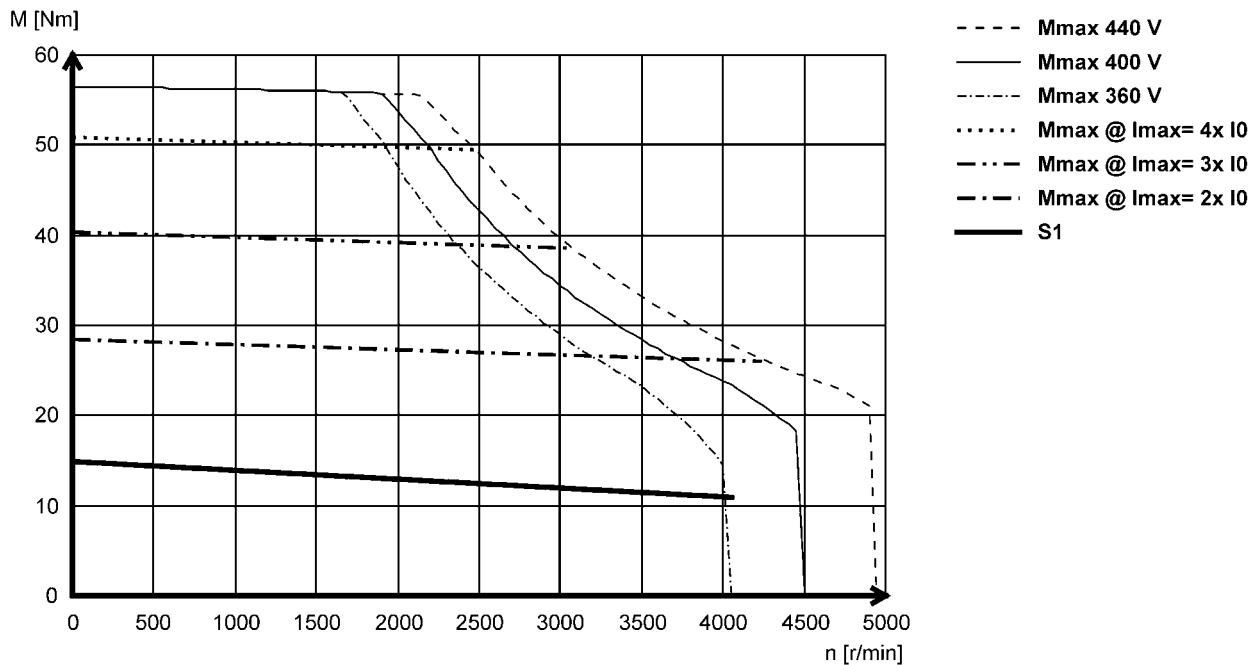

► Other torque characteristics with Lenze inverters can be found at [www.lenze.de/dsc](http://www.lenze.de/dsc).

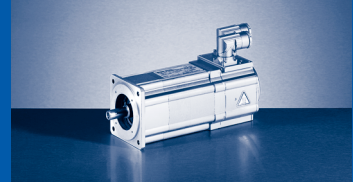

Mains connection 3x 400 V

### MCS14D14

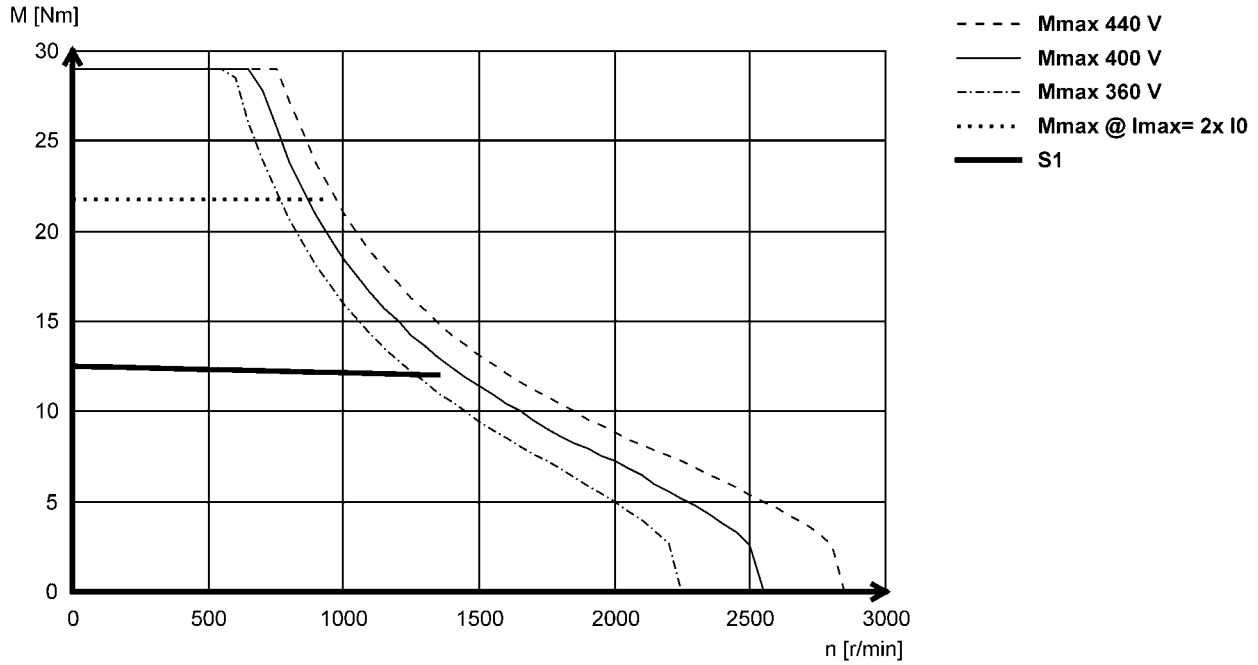

### MCS14D15

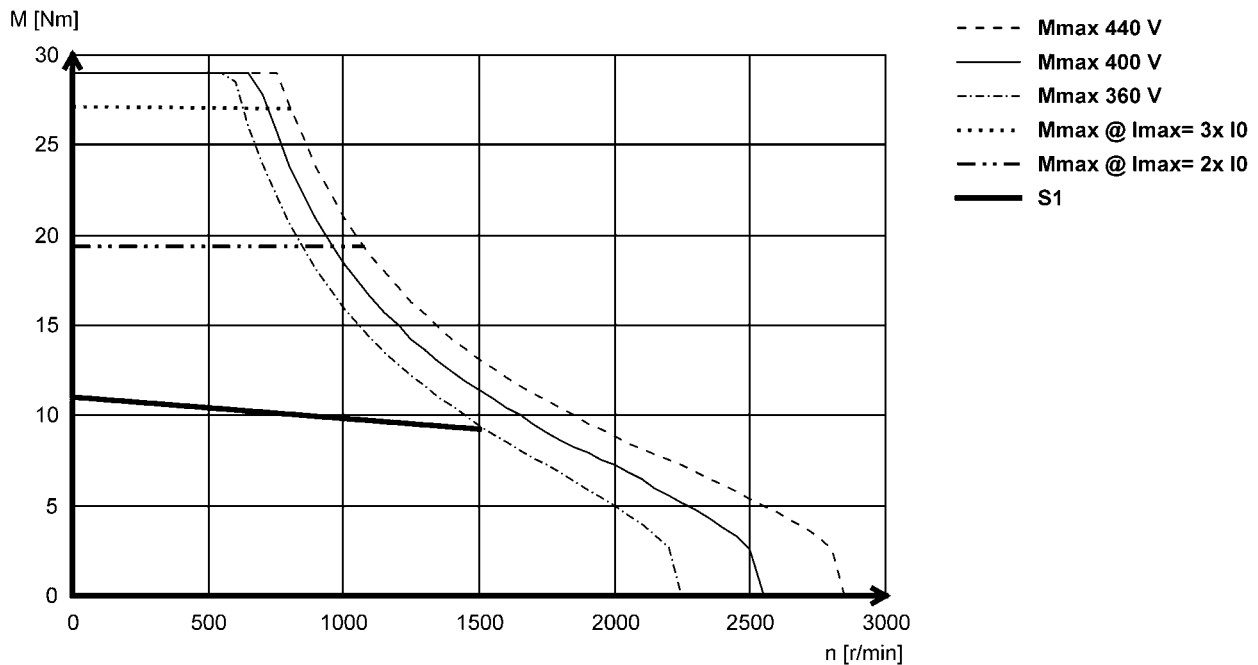

► Other torque characteristics with Lenze inverters can be found at [www.lenze.de/dsc](http://www.lenze.de/dsc).

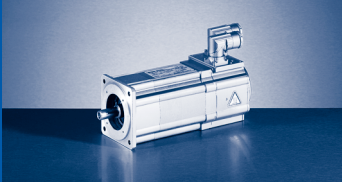

# MCS synchronous servo motors

## Torque characteristics

Mains connection 3x 400 V

### MCS14D30

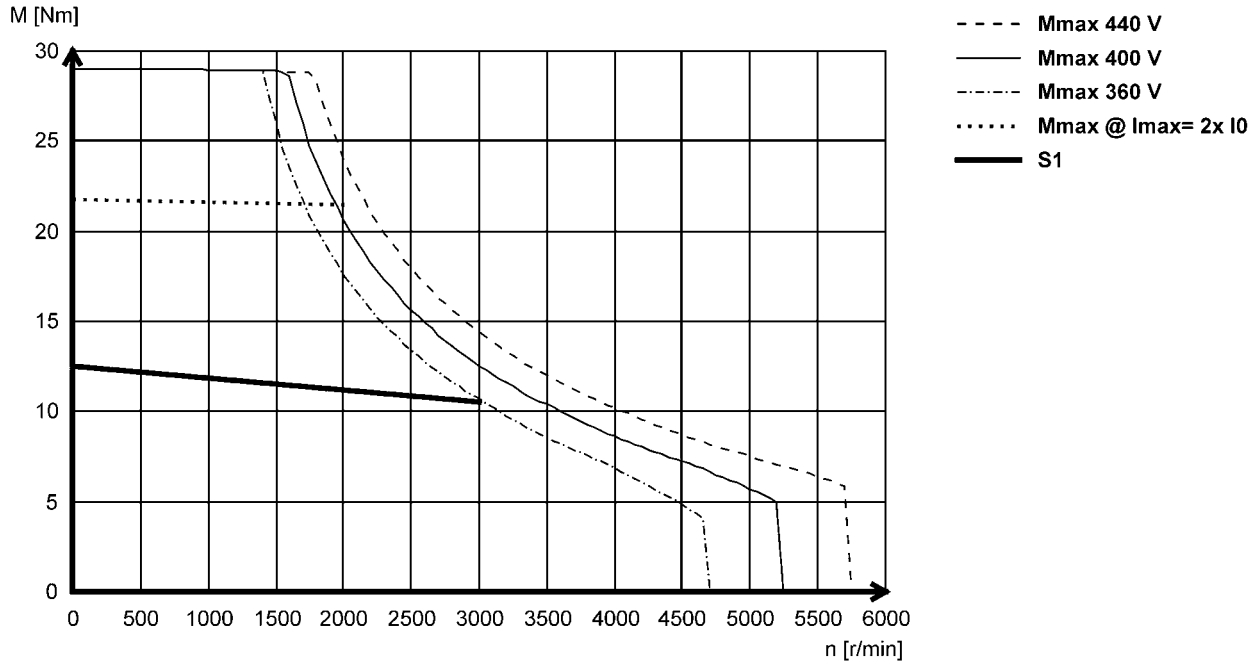

### MCS14D36

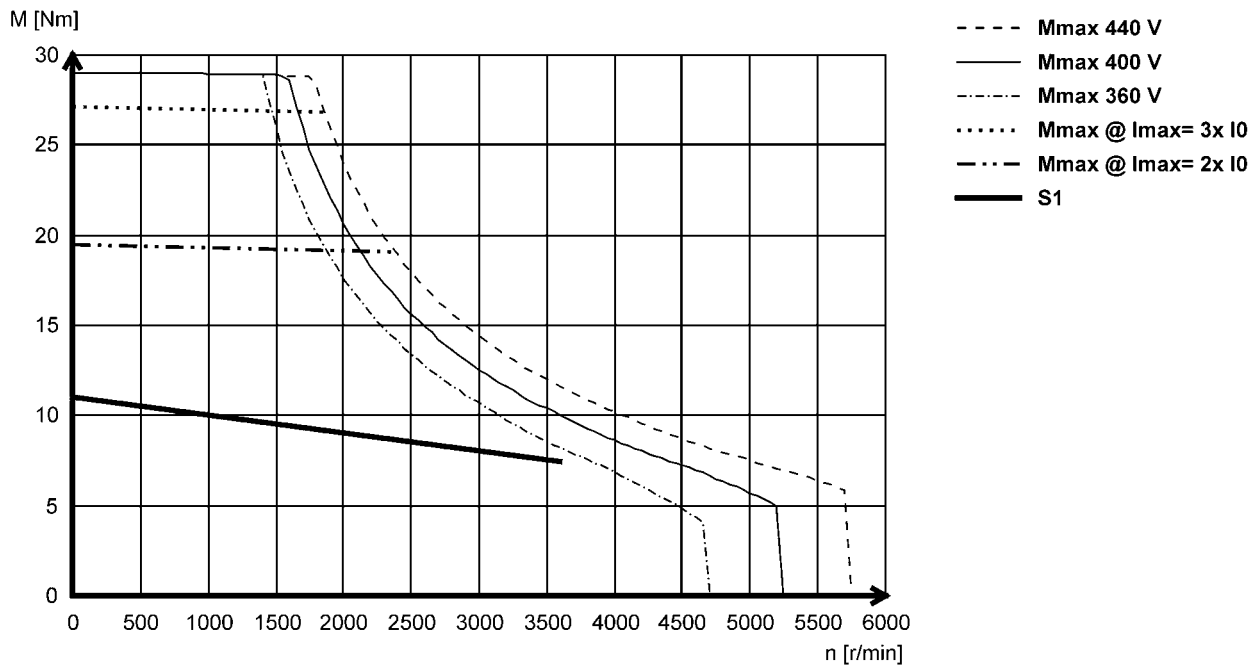

► Other torque characteristics with Lenze inverters can be found at [www.lenze.de/dsc](http://www.lenze.de/dsc).

3

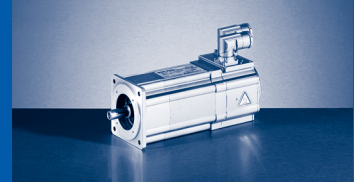

Mains connection 3x 400 V

### MCS14H12

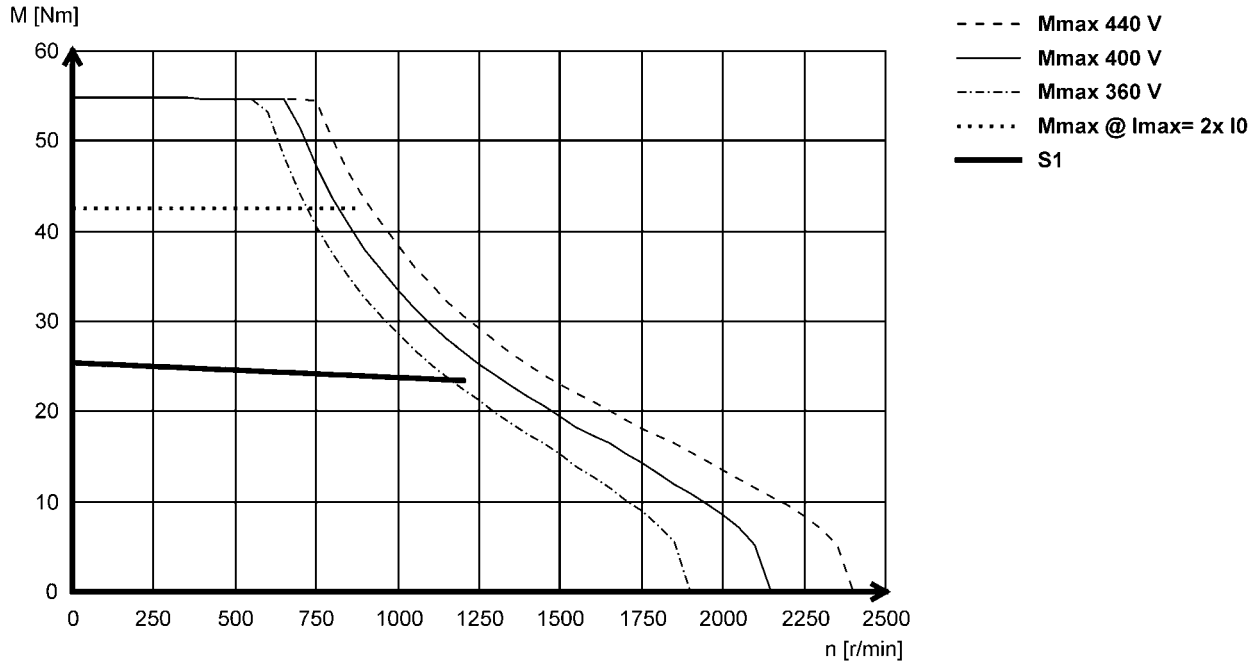

### MCS14H15

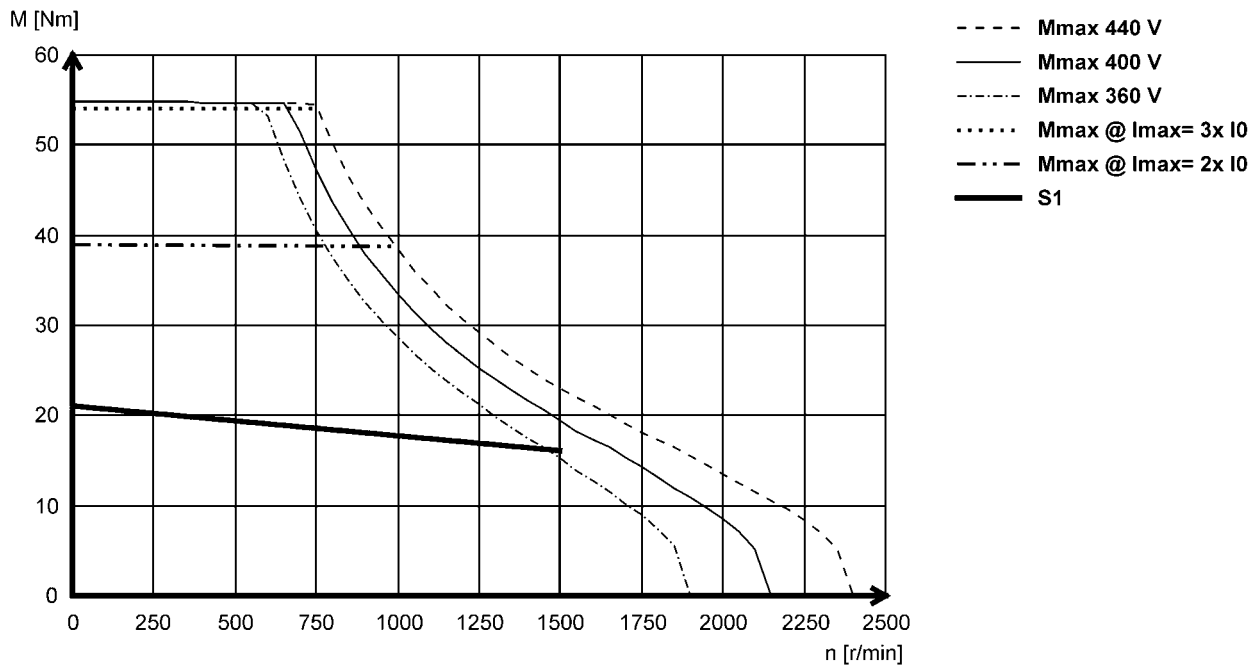

► Other torque characteristics with Lenze inverters can be found at [www.lenze.de/dsc](http://www.lenze.de/dsc).

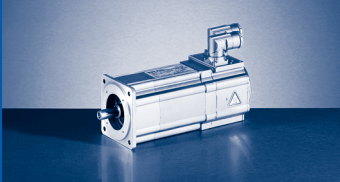

# MCS synchronous servo motors

## Torque characteristics

Mains connection 3x 400 V

### MCS14H28

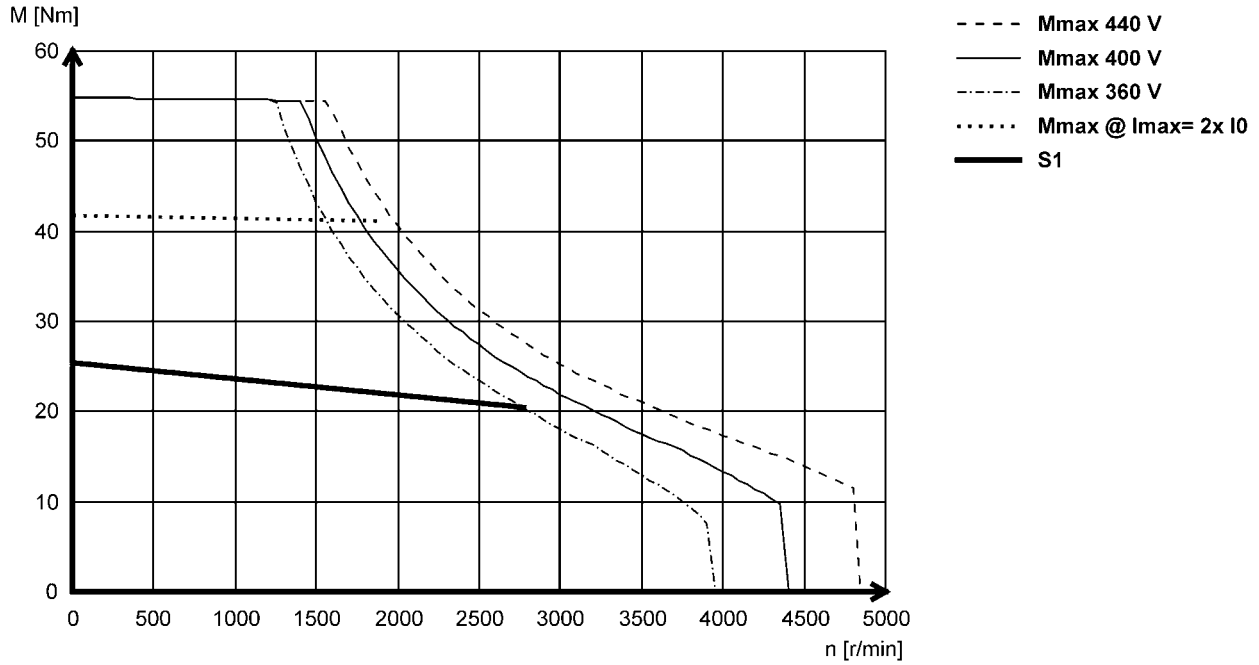

### MCS14H32

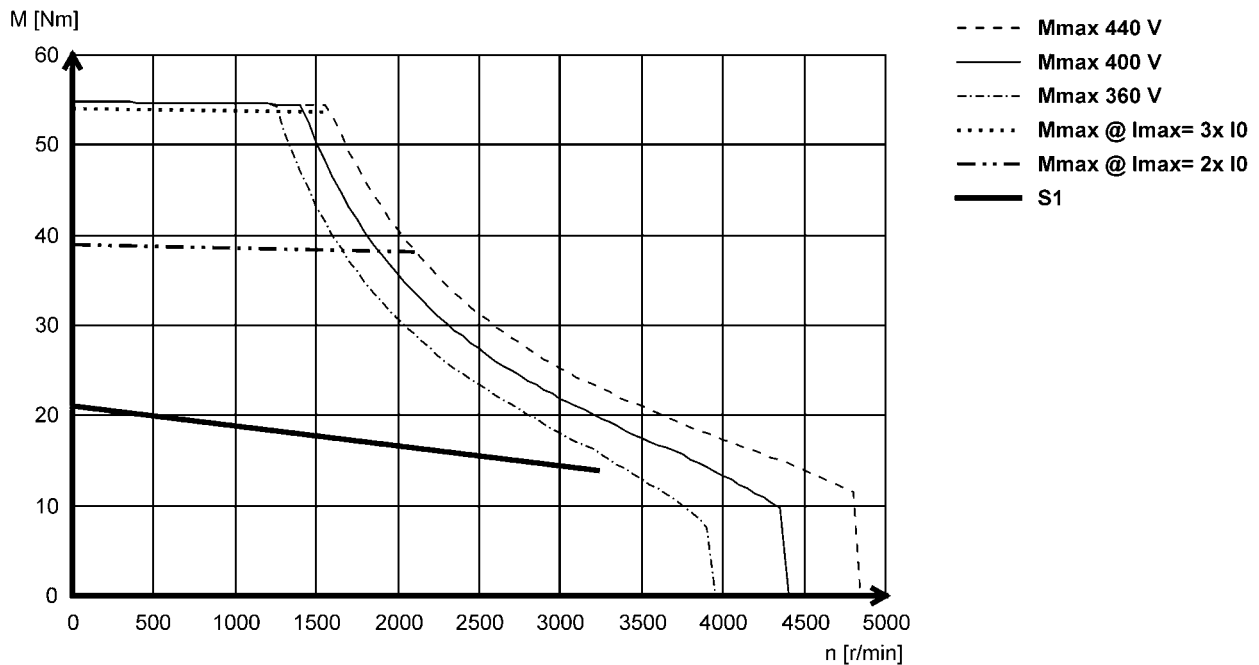

► Other torque characteristics with Lenze inverters can be found at [www.lenze.de/dsc](http://www.lenze.de/dsc).

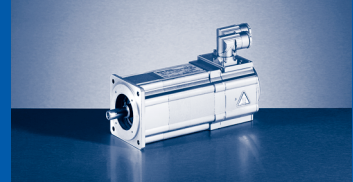

Mains connection 3x 400 V

### MCS14L14

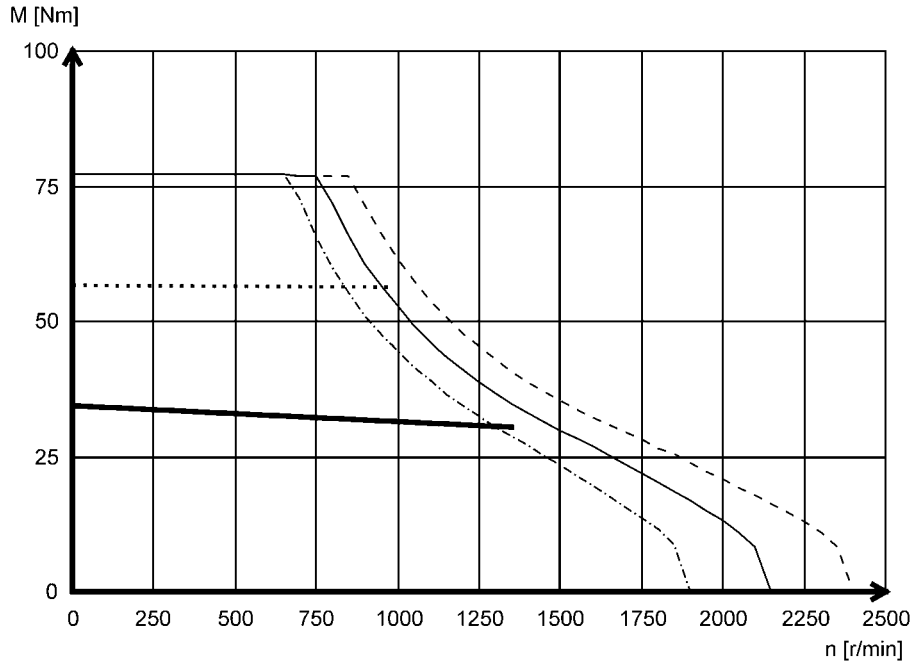

- Mmax 440 V
- Mmax 400 V
- · - · Mmax 360 V
- Mmax @ Imax= 2x I0
- S1

### MCS14L15

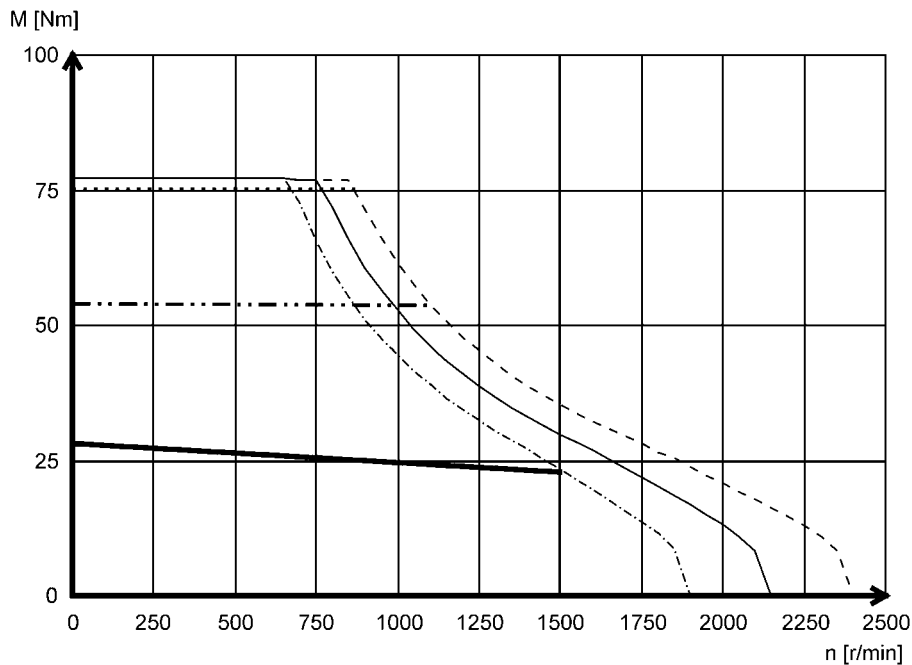

- Mmax 440 V
- Mmax 400 V
- · - · Mmax 360 V
- Mmax @ Imax= 3x I0
- · - · Mmax @ Imax= 2x I0
- S1

► Other torque characteristics with Lenze inverters can be found at [www.lenze.de/dsc](http://www.lenze.de/dsc).

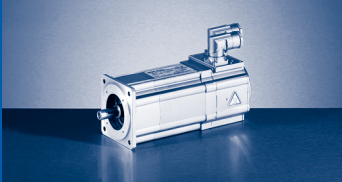

# MCS synchronous servo motors

## Torque characteristics

Mains connection 3x 400 V

### MCS14L30

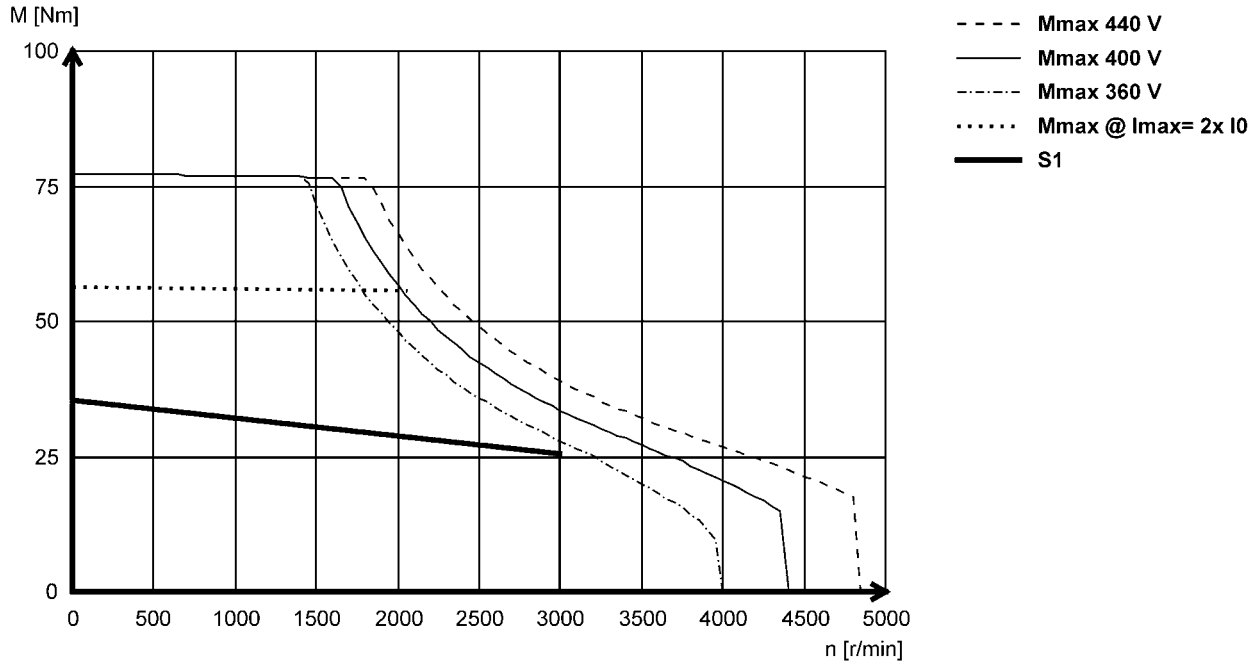

### MCS14L32

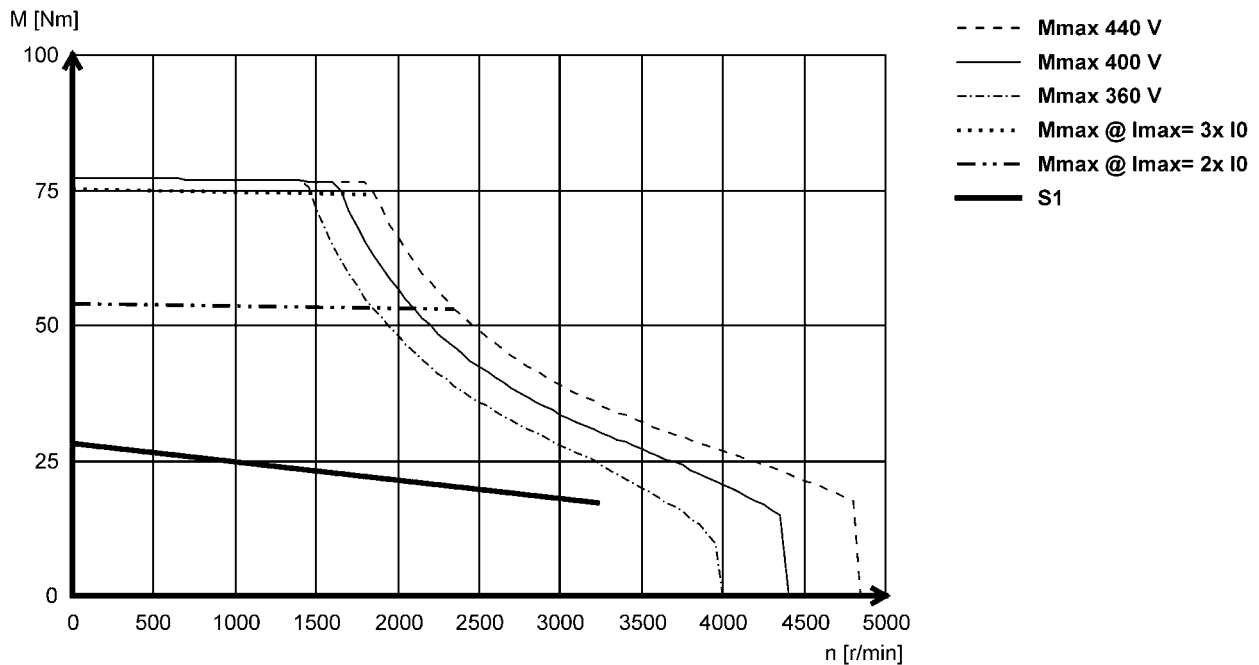

► Other torque characteristics with Lenze inverters can be found at [www.lenze.de/dsc](http://www.lenze.de/dsc).



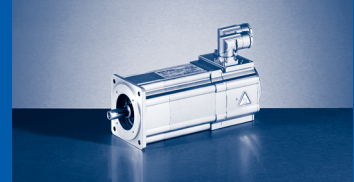

Mains connection 3x 400 V

### MCS14P11

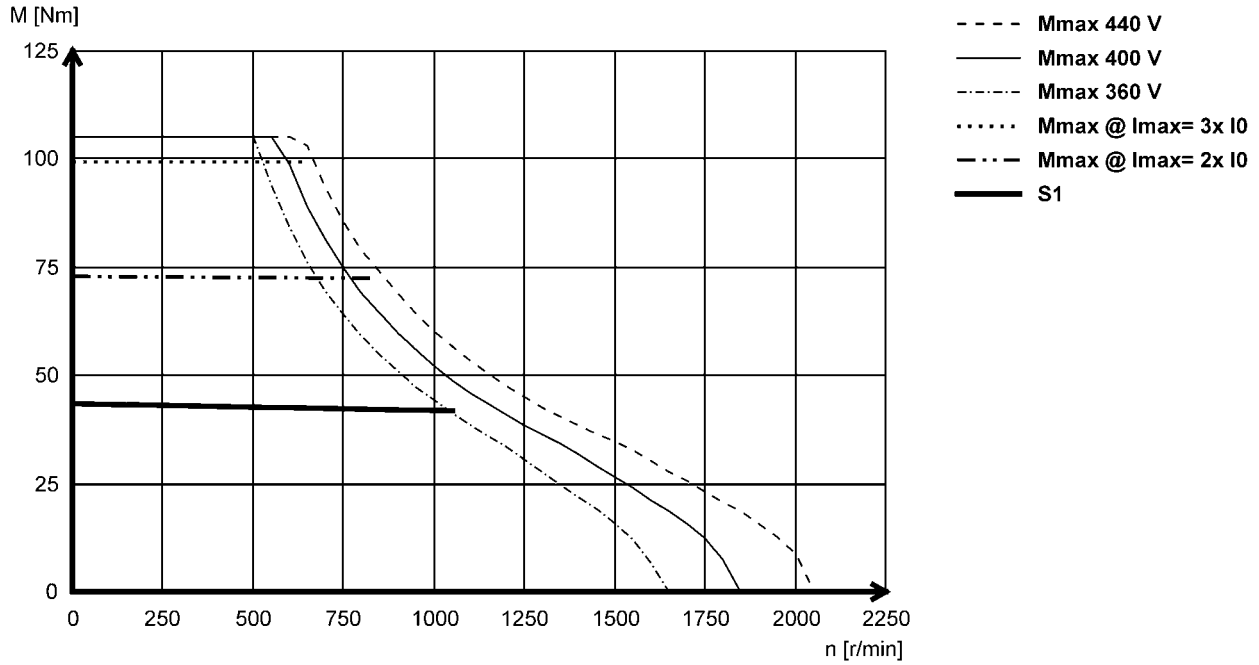

### MCS14P14

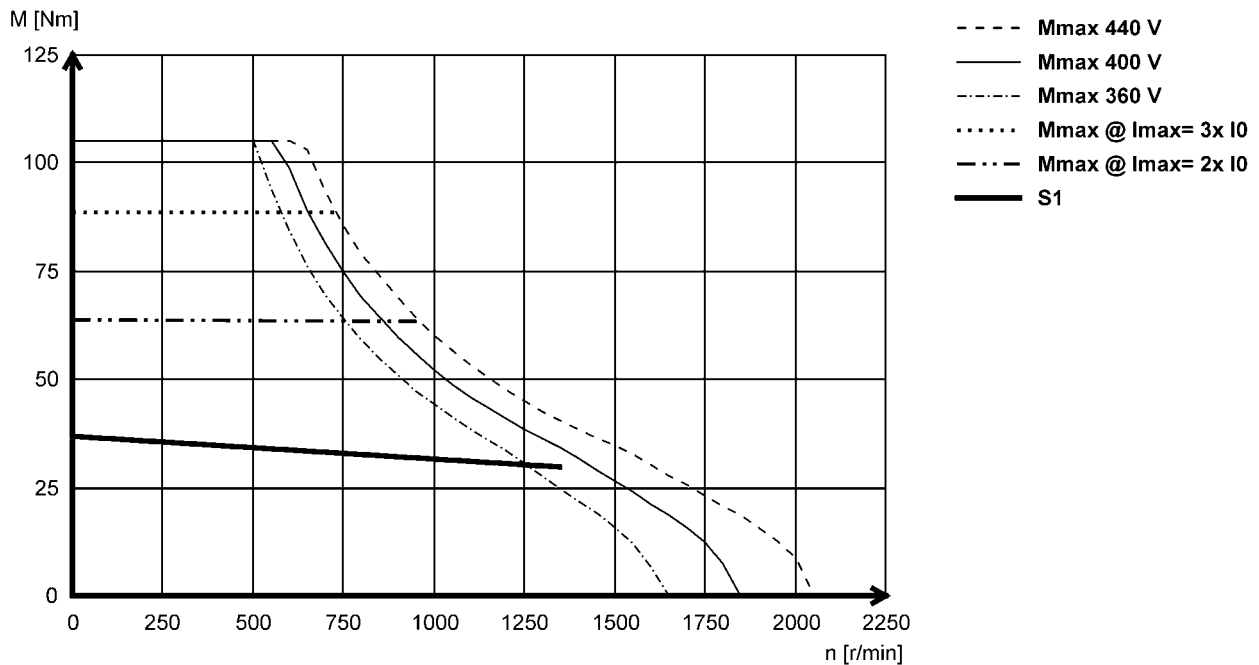

► Other torque characteristics with Lenze inverters can be found at [www.lenze.de/dsc](http://www.lenze.de/dsc).

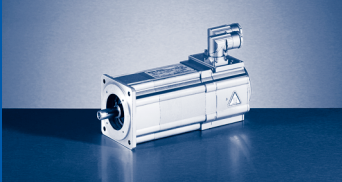

# MCS synchronous servo motors

## Torque characteristics

Mains connection 3x 400 V

### MCS14P26

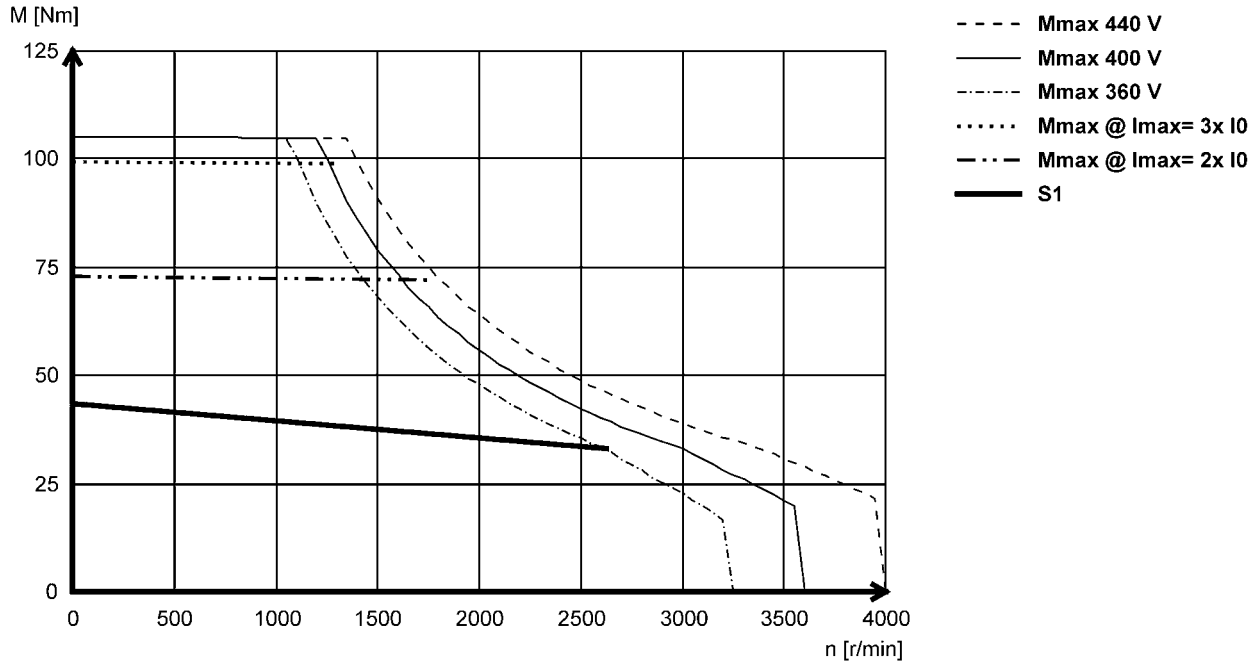

### MCS14P32

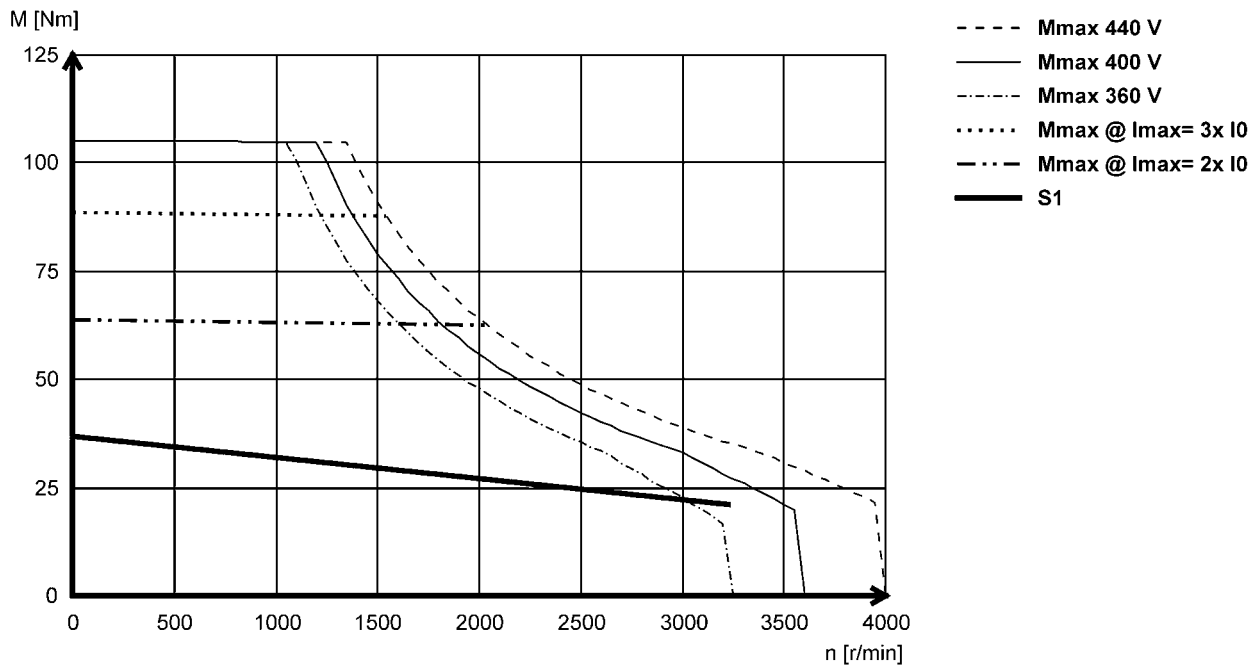

► Other torque characteristics with Lenze inverters can be found at [www.lenze.de/dsc](http://www.lenze.de/dsc).

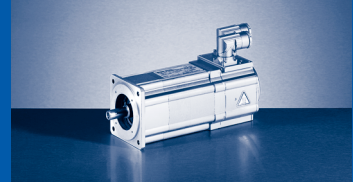

Mains connection 3x 400 V

### MCS19F12

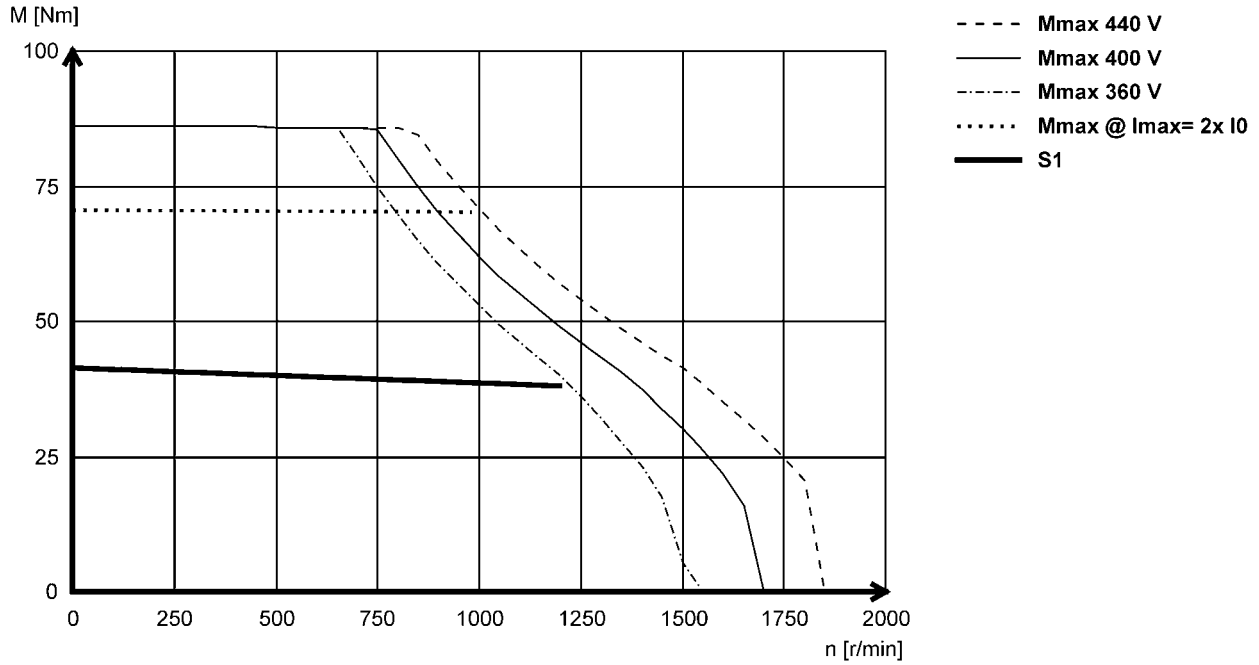

### MCS19F14

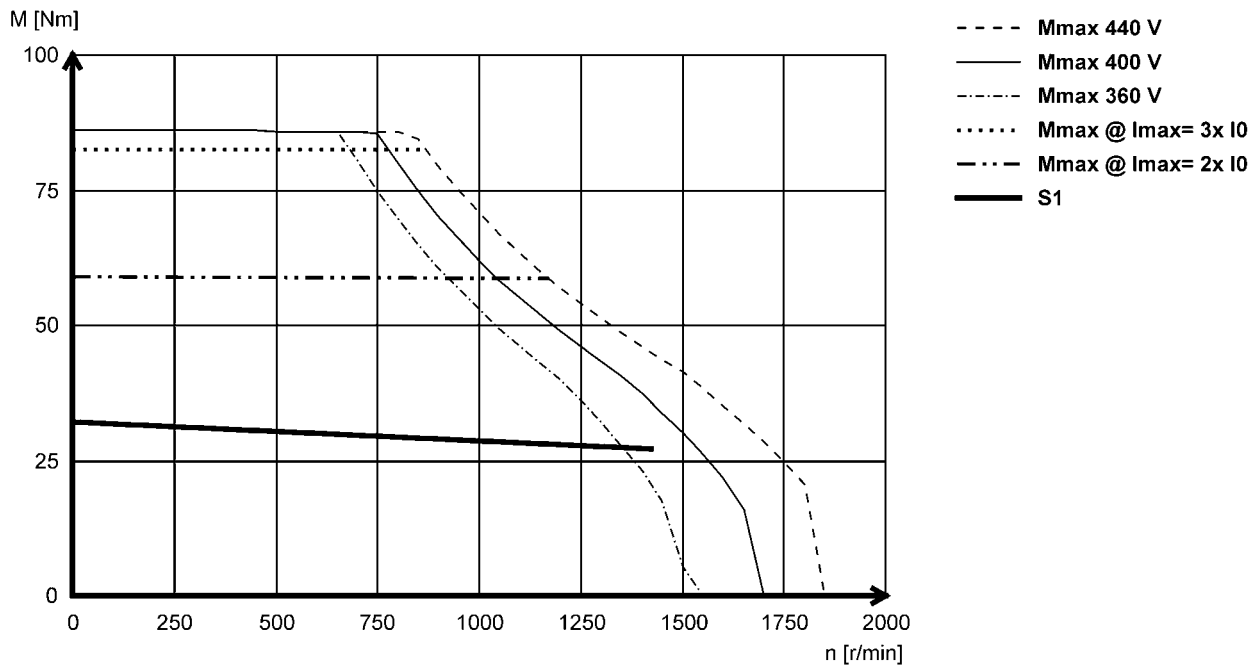

► Other torque characteristics with Lenze inverters can be found at [www.lenze.de/dsc](http://www.lenze.de/dsc).

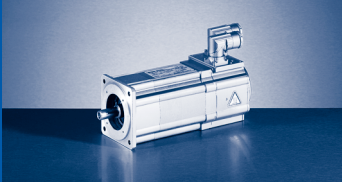

# MCS synchronous servo motors

## Torque characteristics

Mains connection 3x 400 V

### MCS19F29

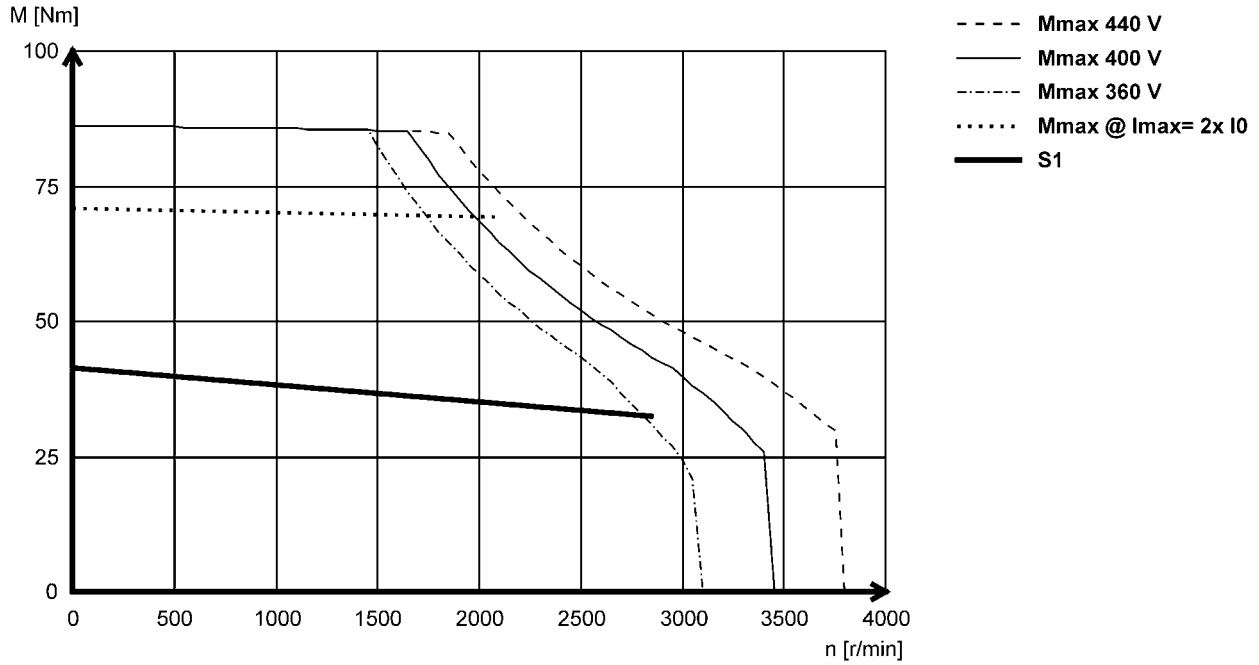

### MCS19F30

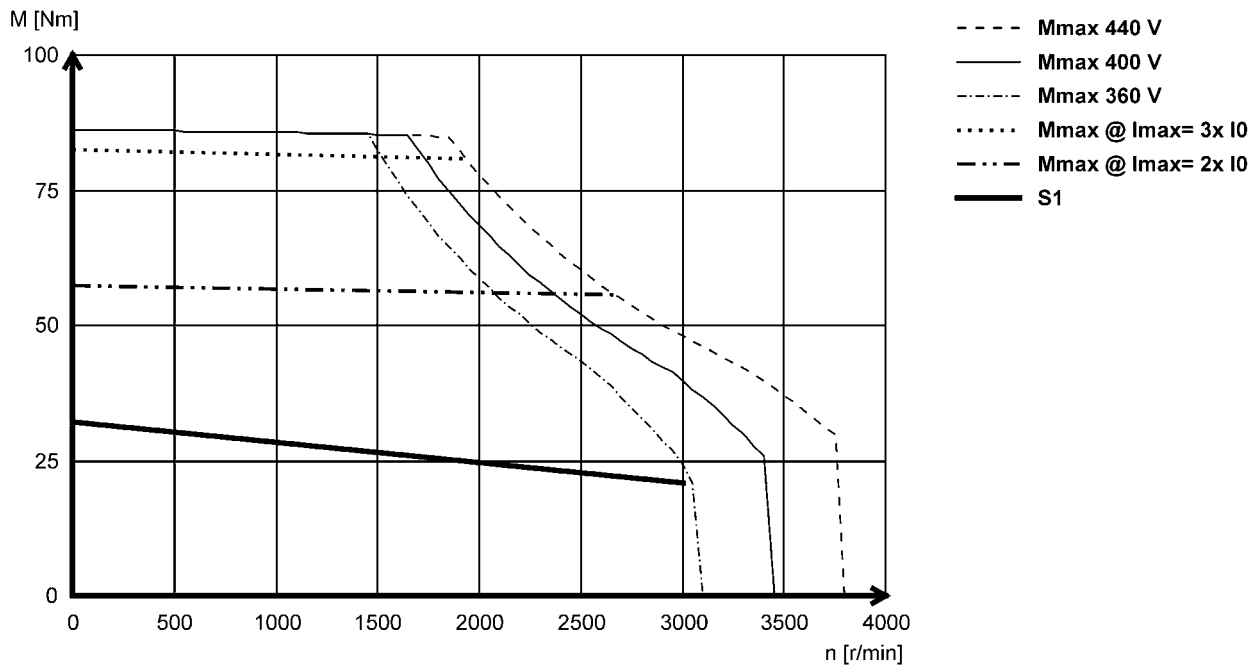

► Other torque characteristics with Lenze inverters can be found at [www.lenze.de/dsc](http://www.lenze.de/dsc).

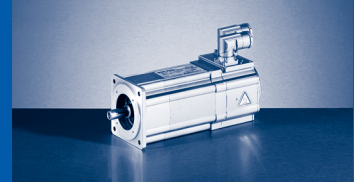

Mains connection 3x 400 V

### MCS19J12

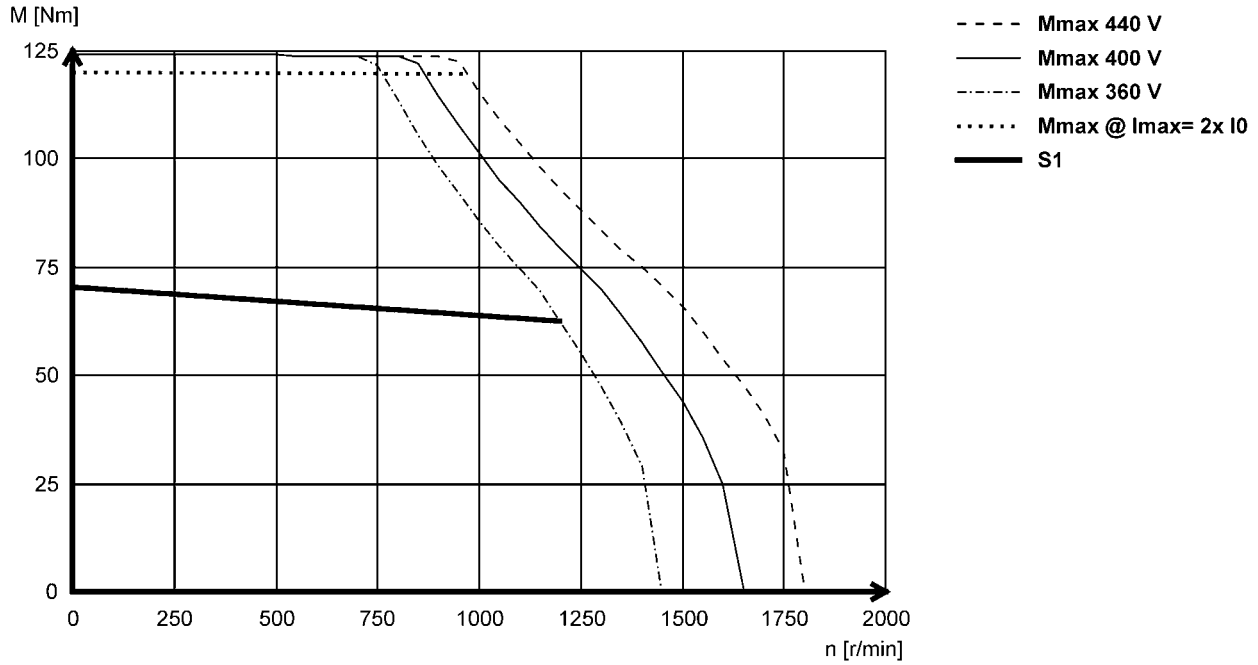

### MCS19J14

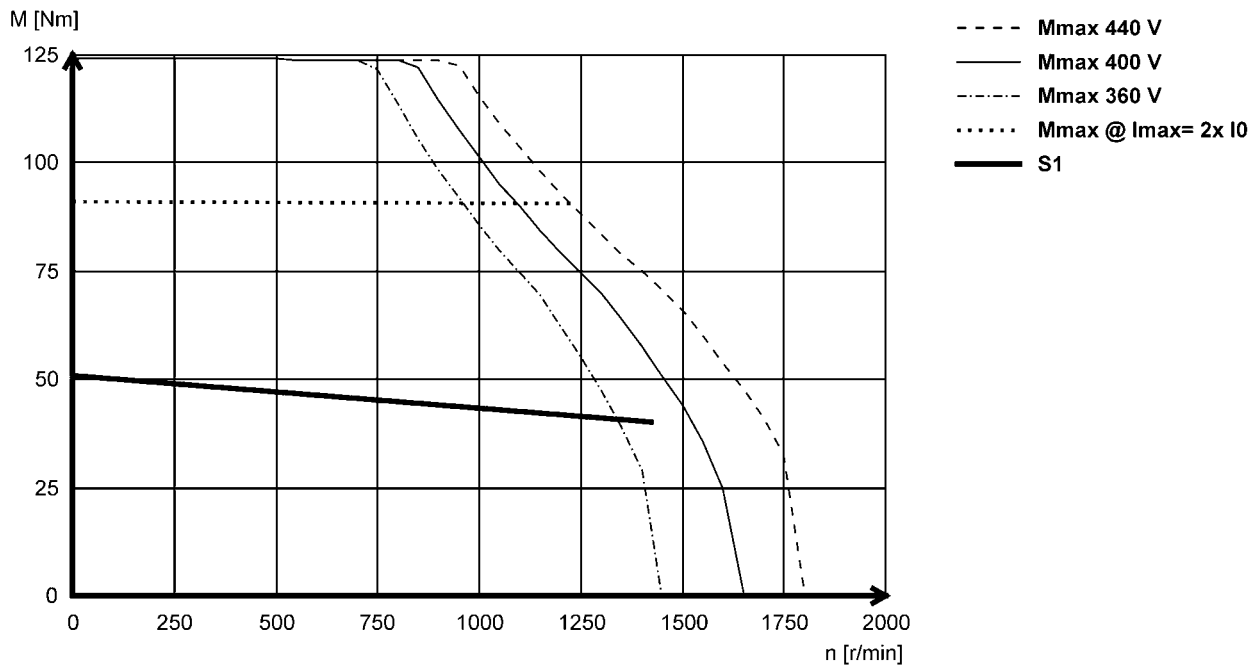

► Other torque characteristics with Lenze inverters can be found at [www.lenze.de/dsc](http://www.lenze.de/dsc).

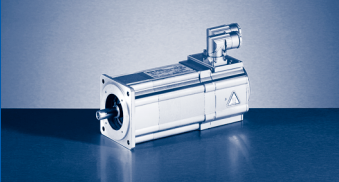

# MCS synchronous servo motors

## Torque characteristics

Mains connection 3x 400 V

### MCS19J29

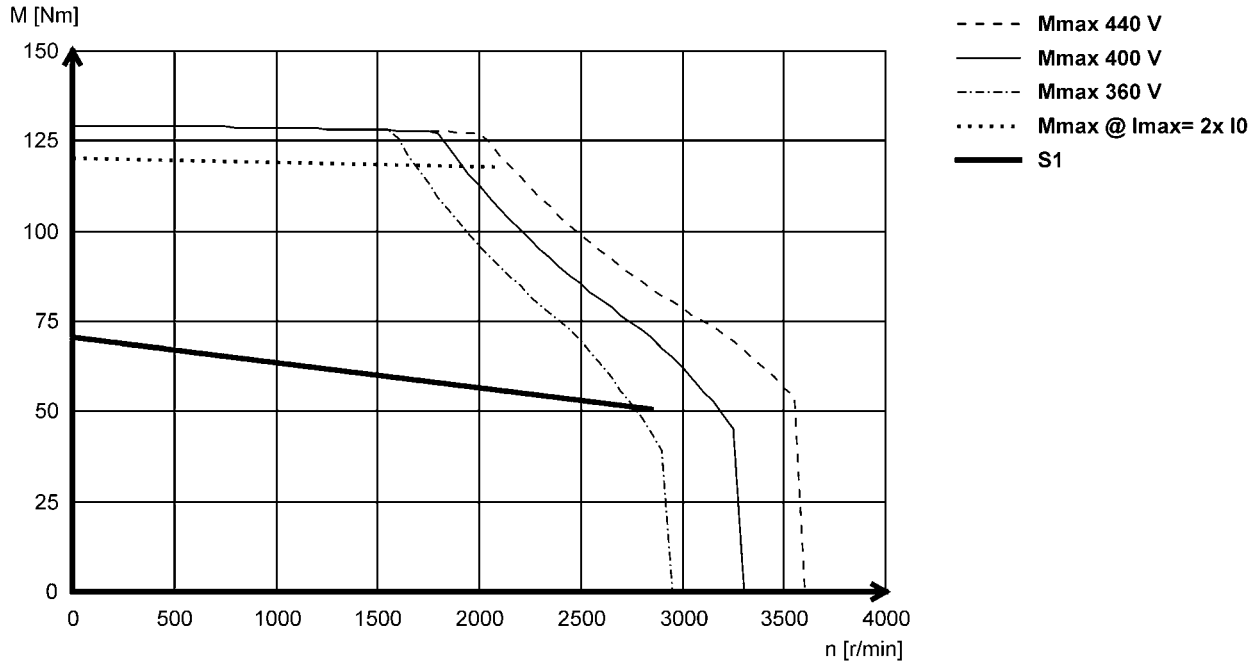

### MCS19J30

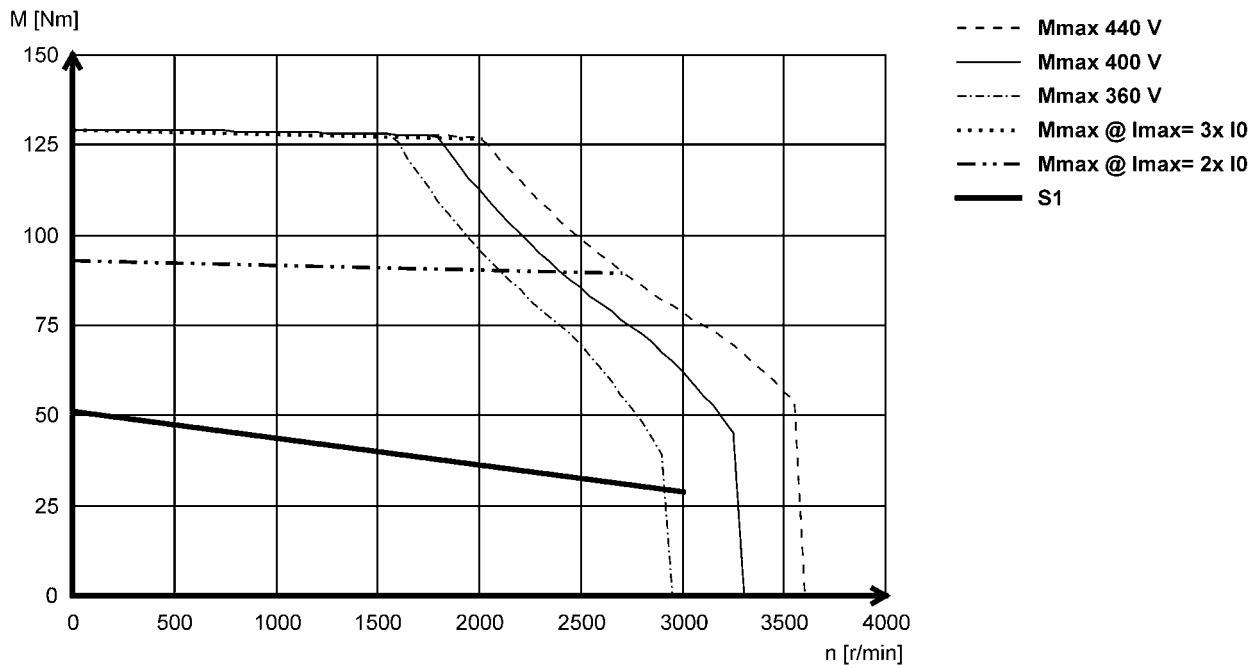

► Other torque characteristics with Lenze inverters can be found at [www.lenze.de/dsc](http://www.lenze.de/dsc).

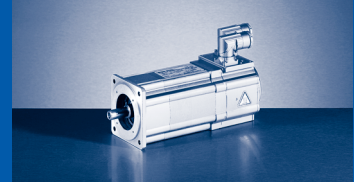

### Mains connection 3x 400 V

#### MCS19P12

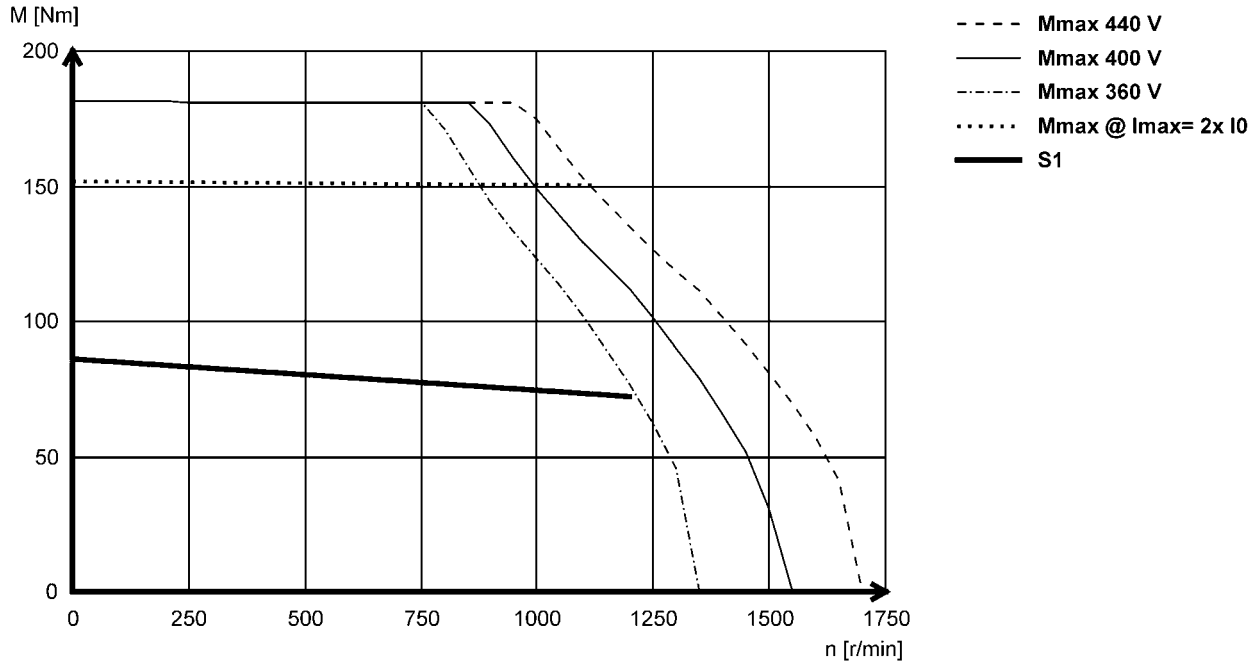

#### MCS19P14

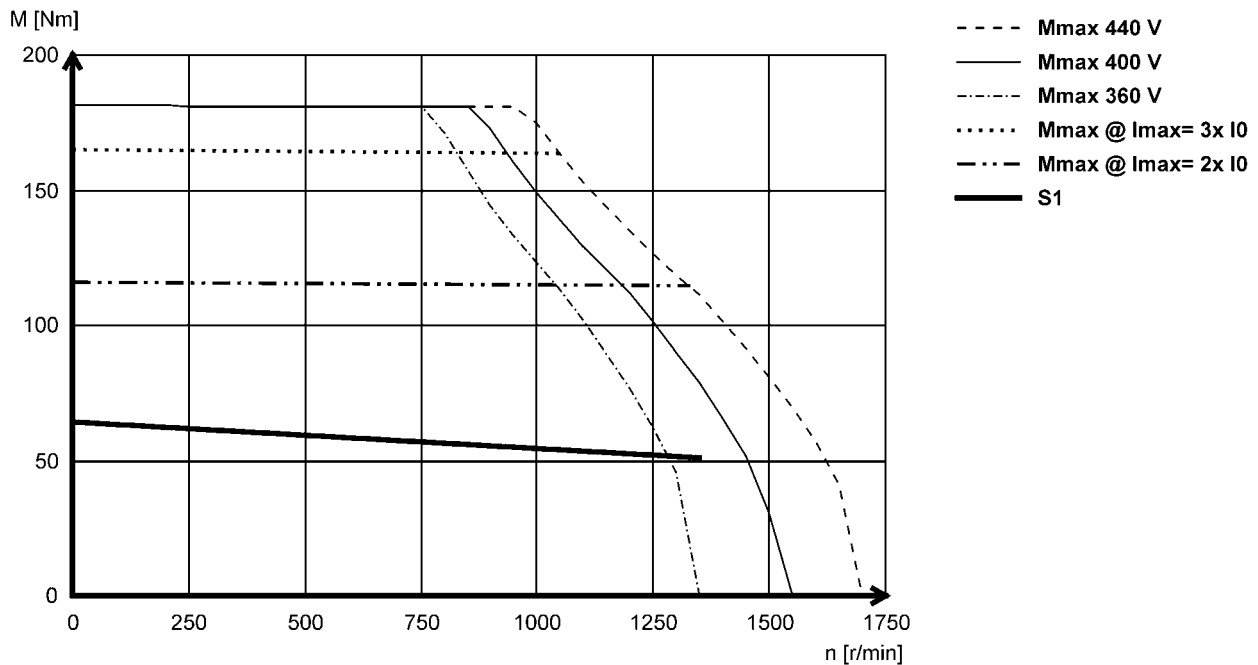

► Other torque characteristics with Lenze inverters can be found at [www.lenze.de/dsc](http://www.lenze.de/dsc).

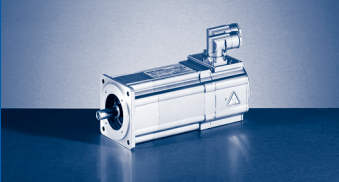

# MCS synchronous servo motors

## Torque characteristics

Mains connection 3x 400 V

### MCS19P29

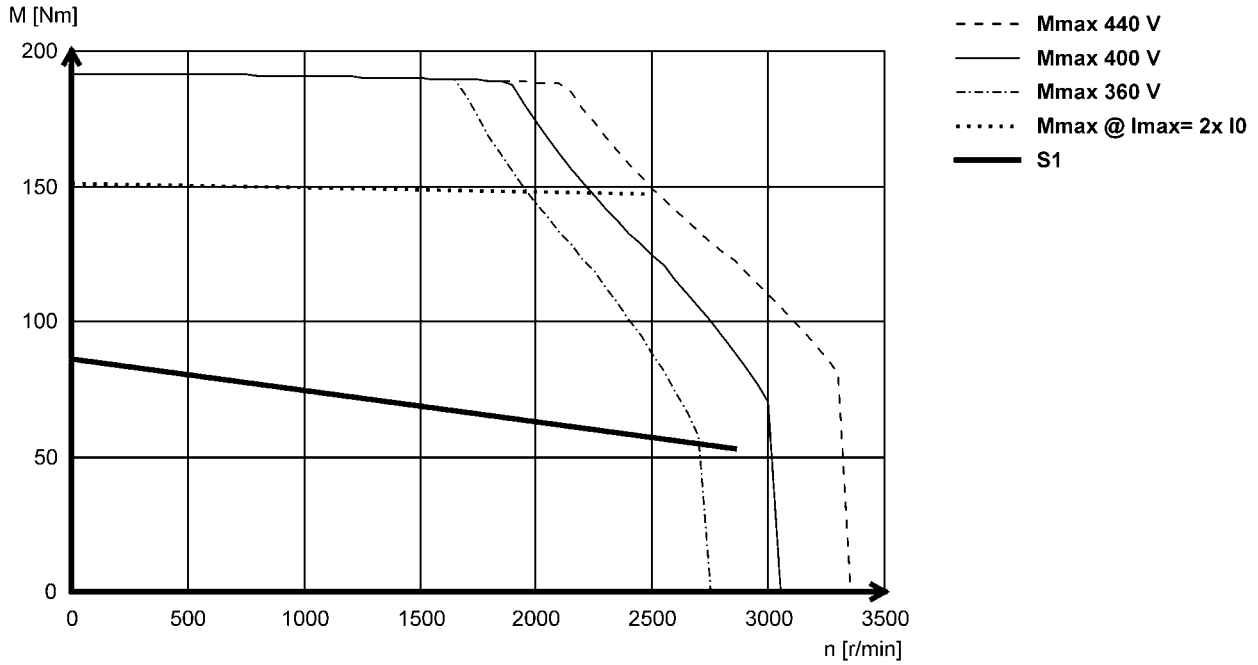

### MCS19P30

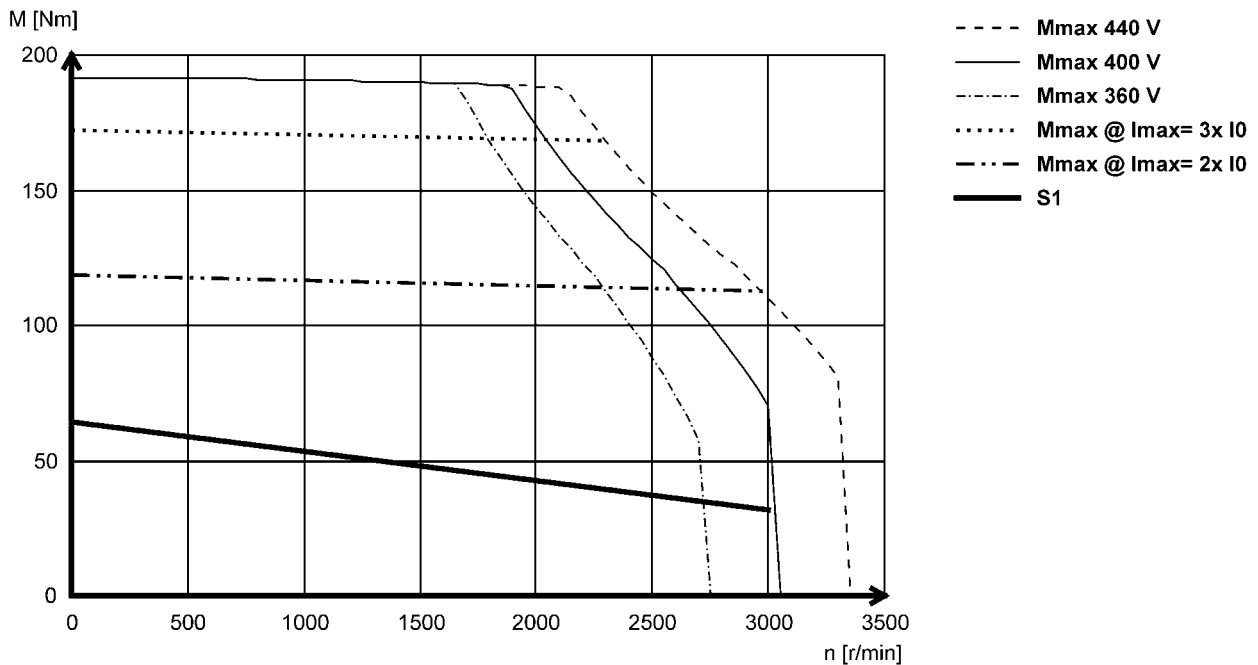

► Other torque characteristics with Lenze inverters can be found at [www.lenze.de/dsc](http://www.lenze.de/dsc).



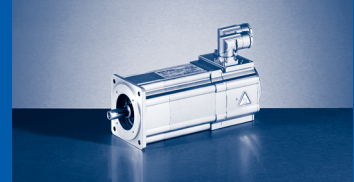

### Mains connection 3x 230 V

#### MCS06C41L

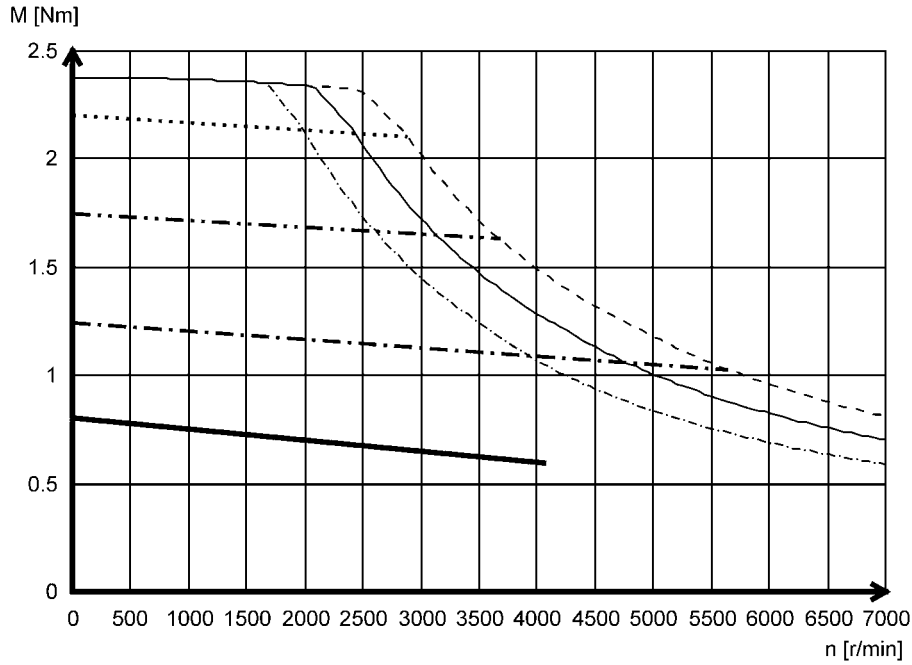

#### MCS06C60L

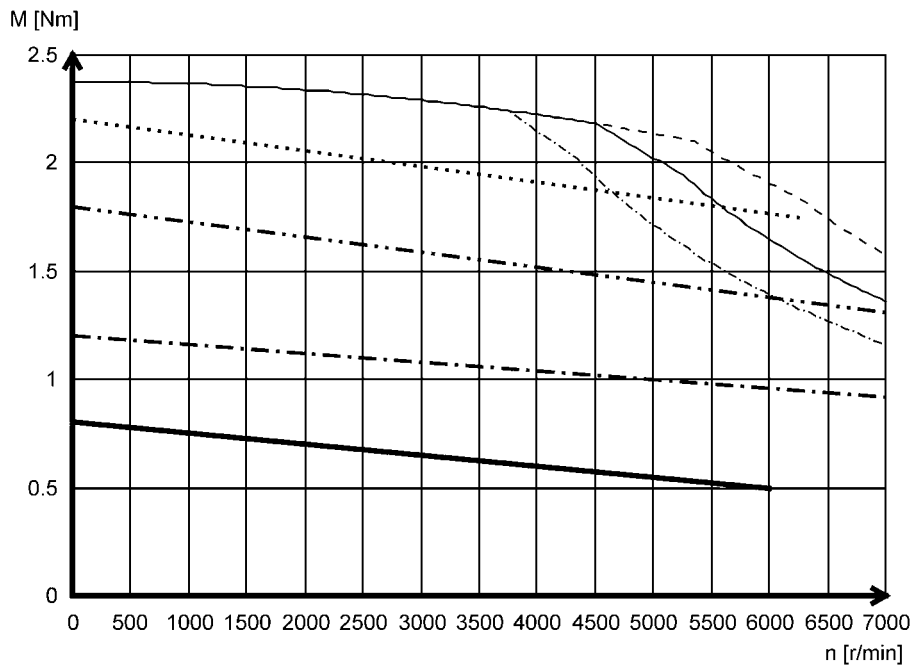

► Other torque characteristics with Lenze inverters can be found at [www.lenze.de/dsc](http://www.lenze.de/dsc).

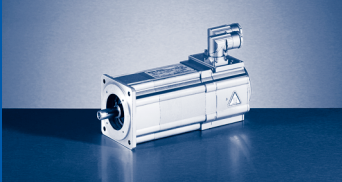

# MCS synchronous servo motors

## Torque characteristics

Mains connection 3x 230 V

### MCS06F41L

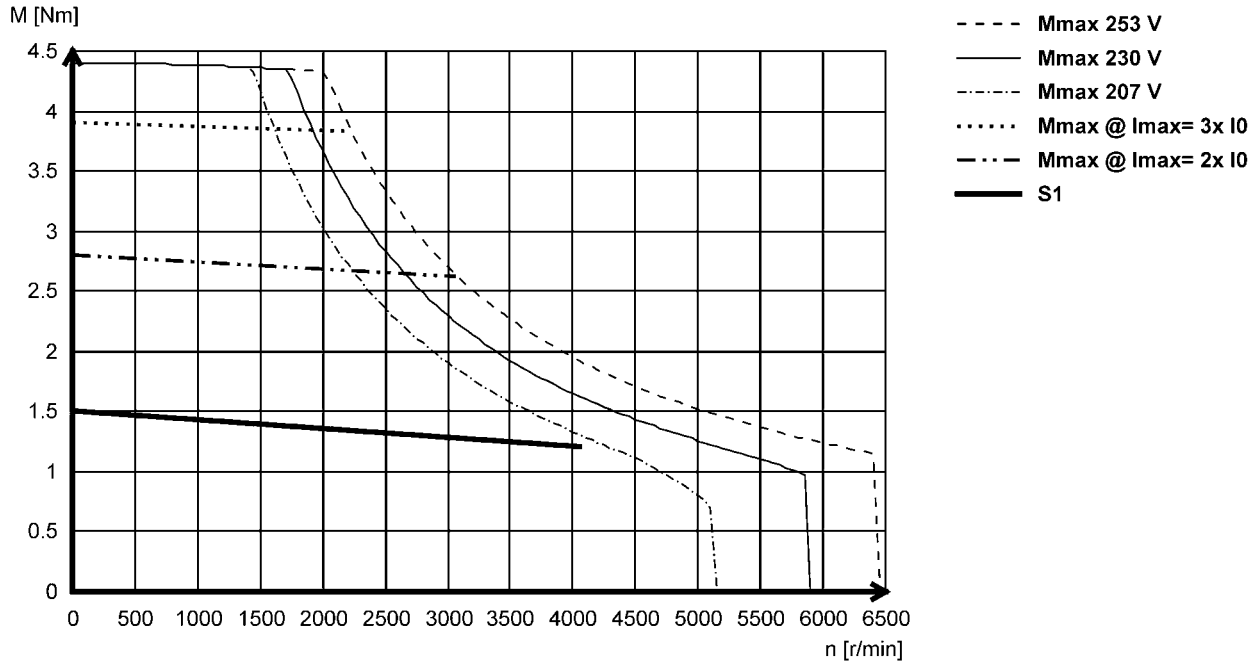

### MCS06F60L

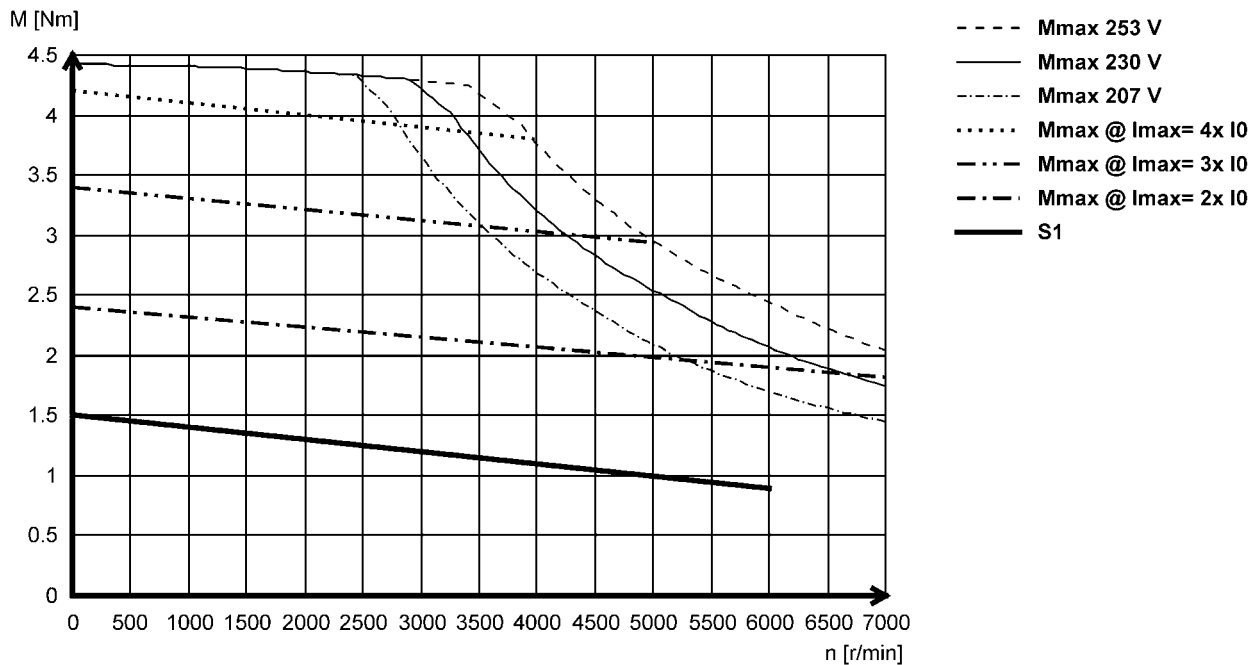

► Other torque characteristics with Lenze inverters can be found at [www.lenze.de/dsc](http://www.lenze.de/dsc).

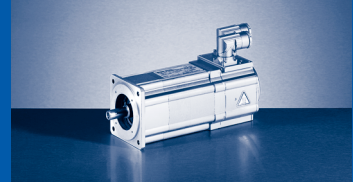

Mains connection 3x 230 V

### MCS06I41L

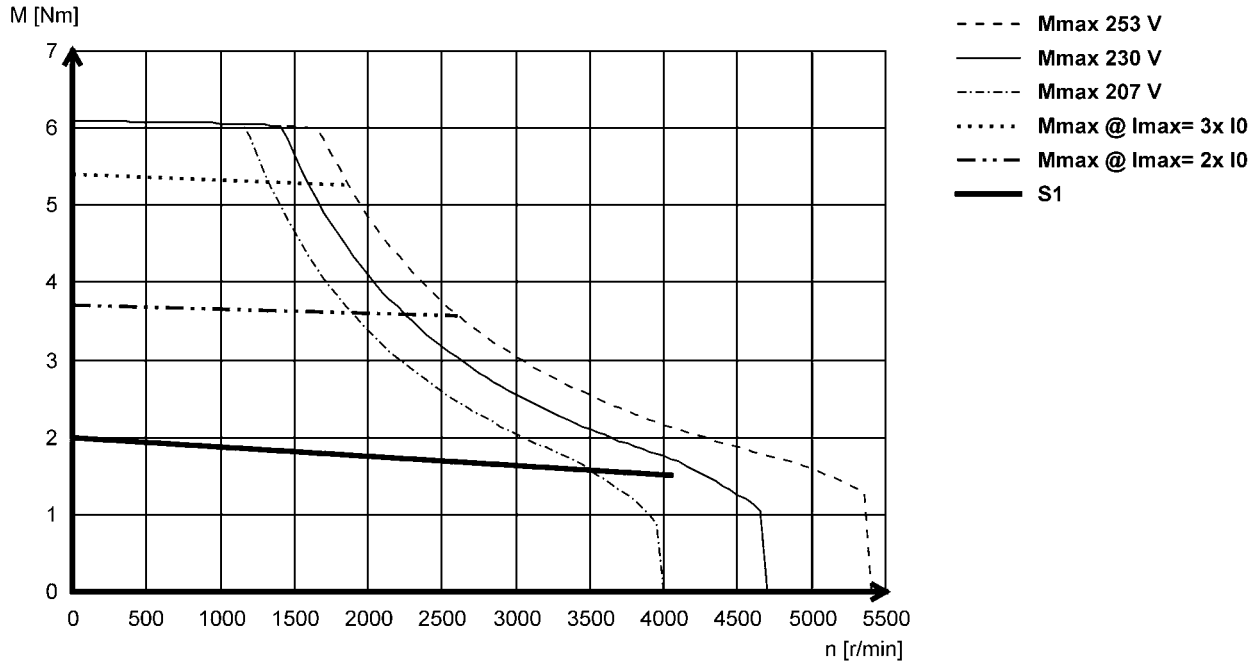

### MCS06I60L

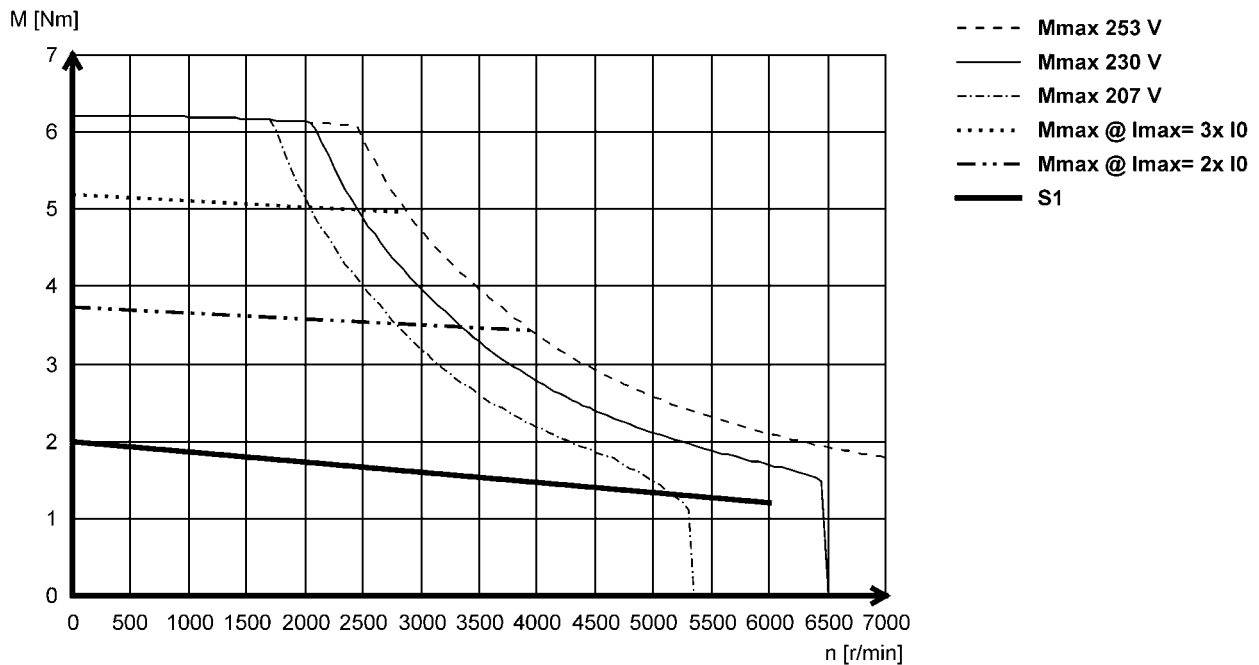

► Other torque characteristics with Lenze inverters can be found at [www.lenze.de/dsc](http://www.lenze.de/dsc).

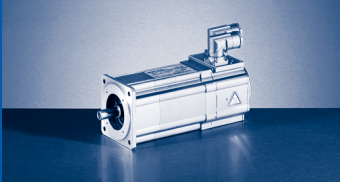

# MCS synchronous servo motors

## Torque characteristics

Mains connection 3x 230 V

### MCS09D41L

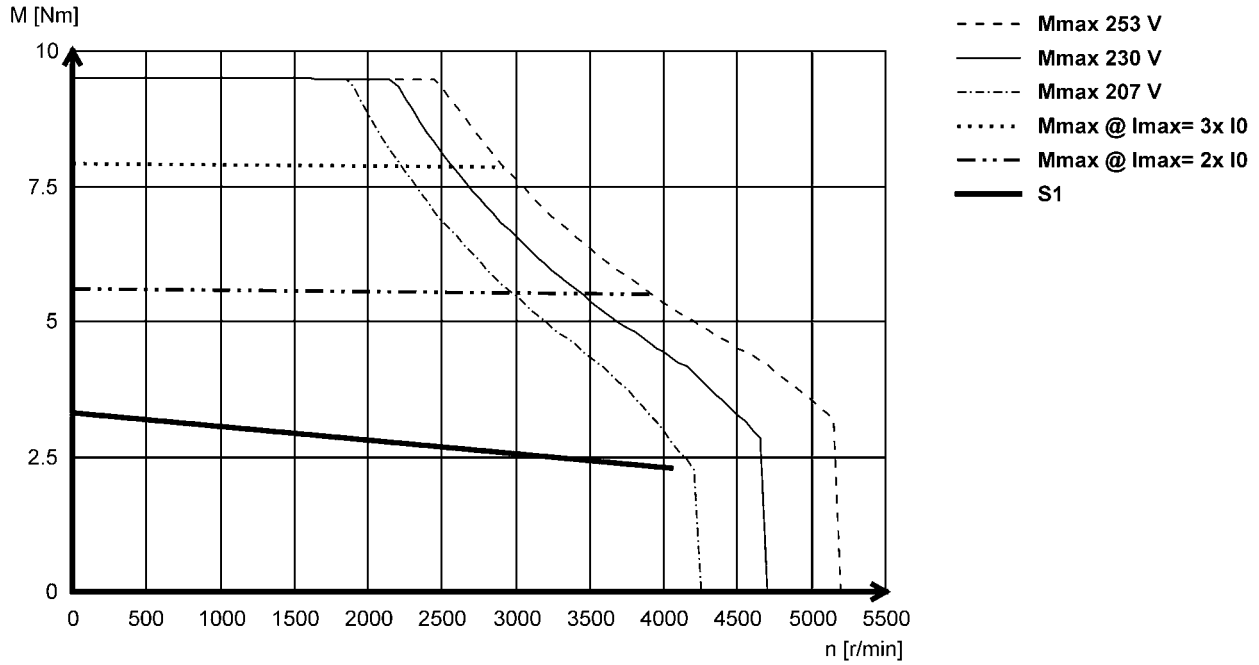

### MCS09D60L

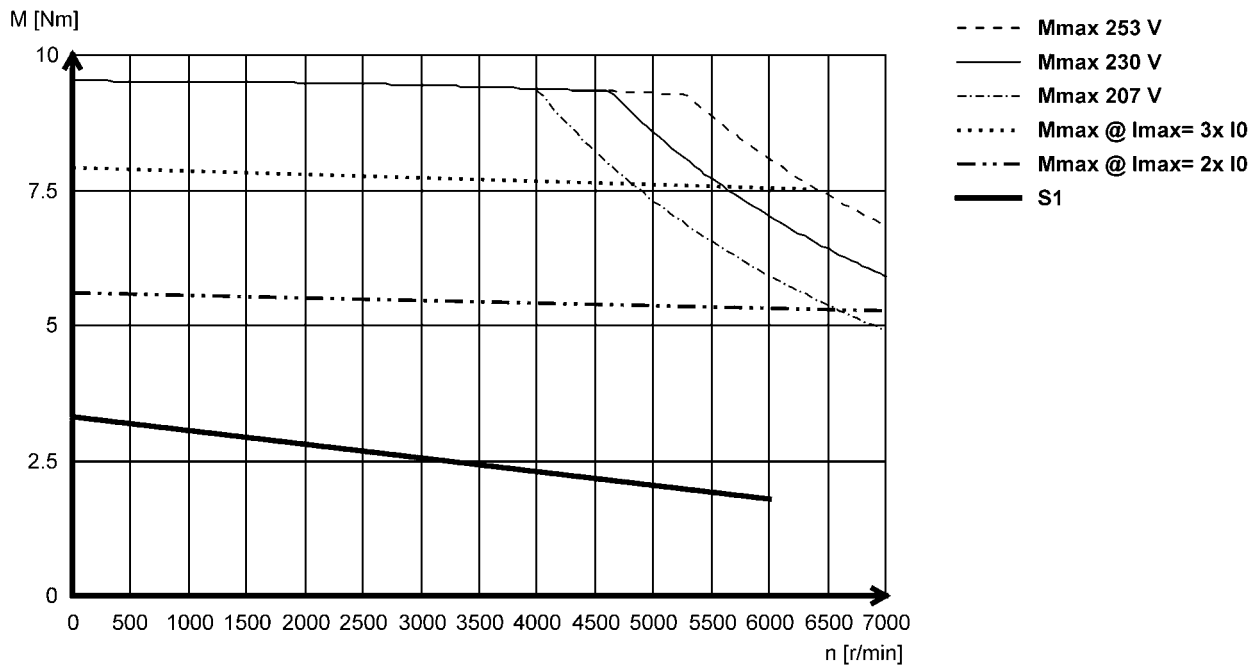

► Other torque characteristics with Lenze inverters can be found at [www.lenze.de/dsc](http://www.lenze.de/dsc).

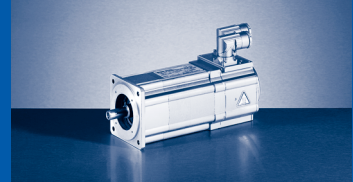

Mains connection 3x 230 V

### MCS09F38L

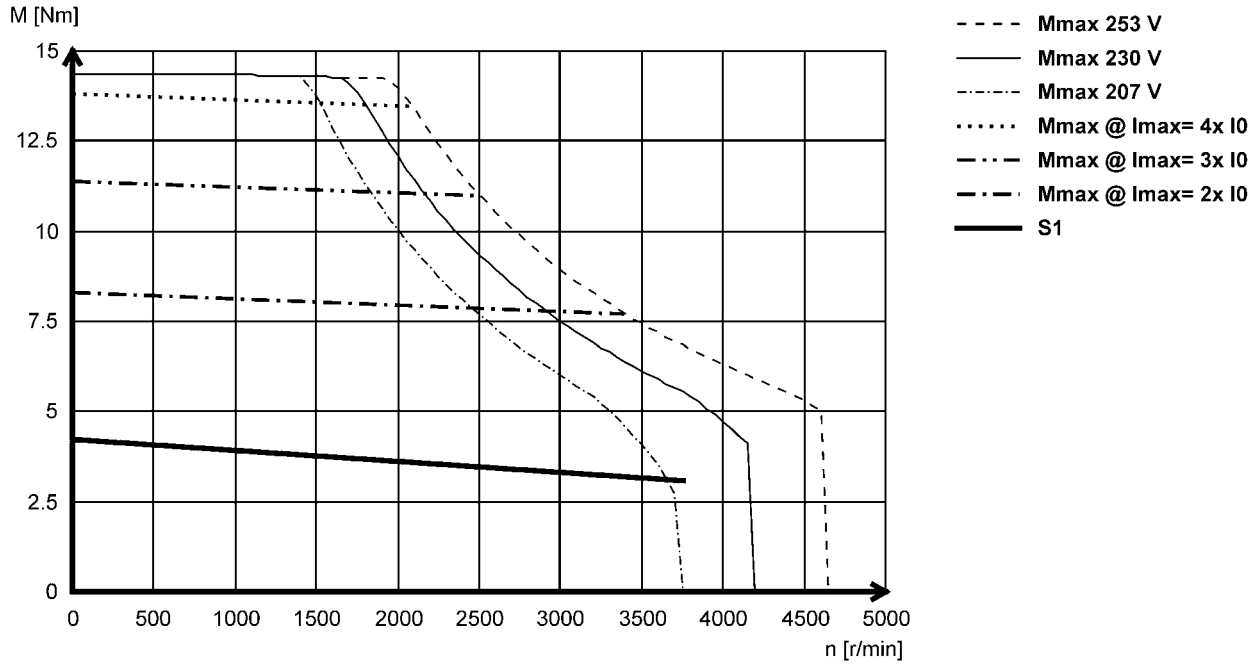

### MCS09F60L

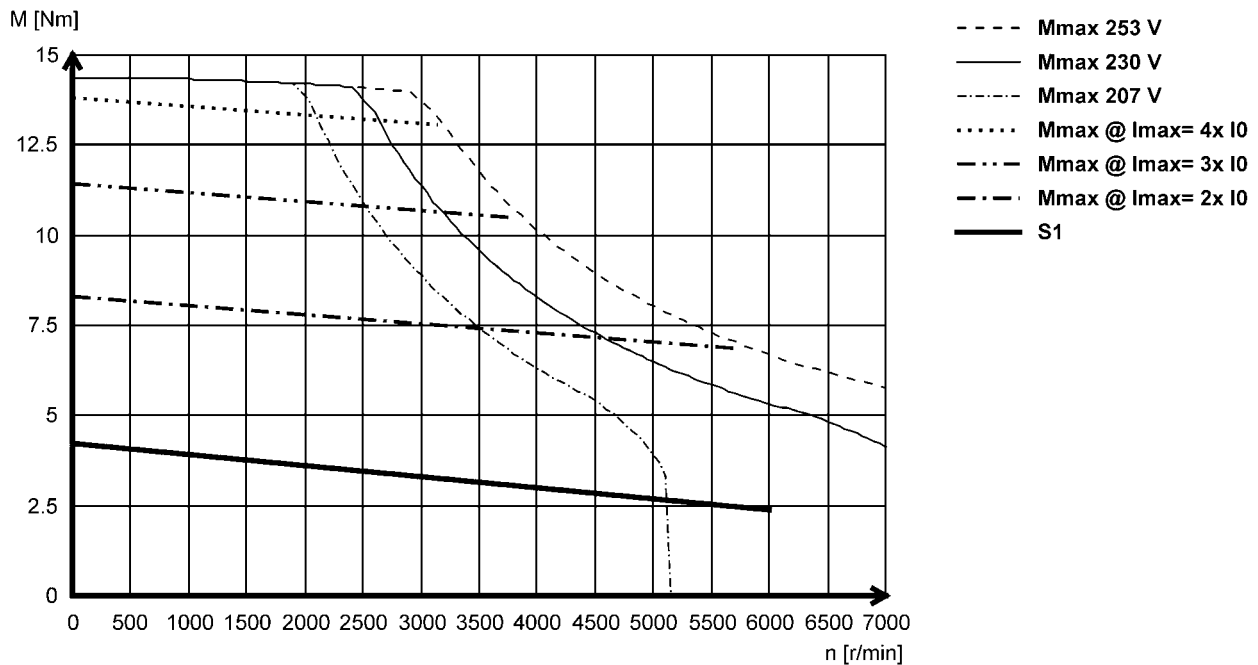

► Other torque characteristics with Lenze inverters can be found at [www.lenze.de/dsc](http://www.lenze.de/dsc).

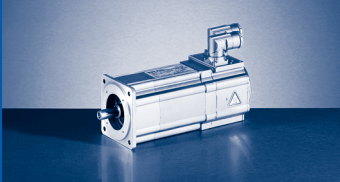

# MCS synchronous servo motors

## Torque characteristics

Mains connection 3x 230 V

### MCS09H41L

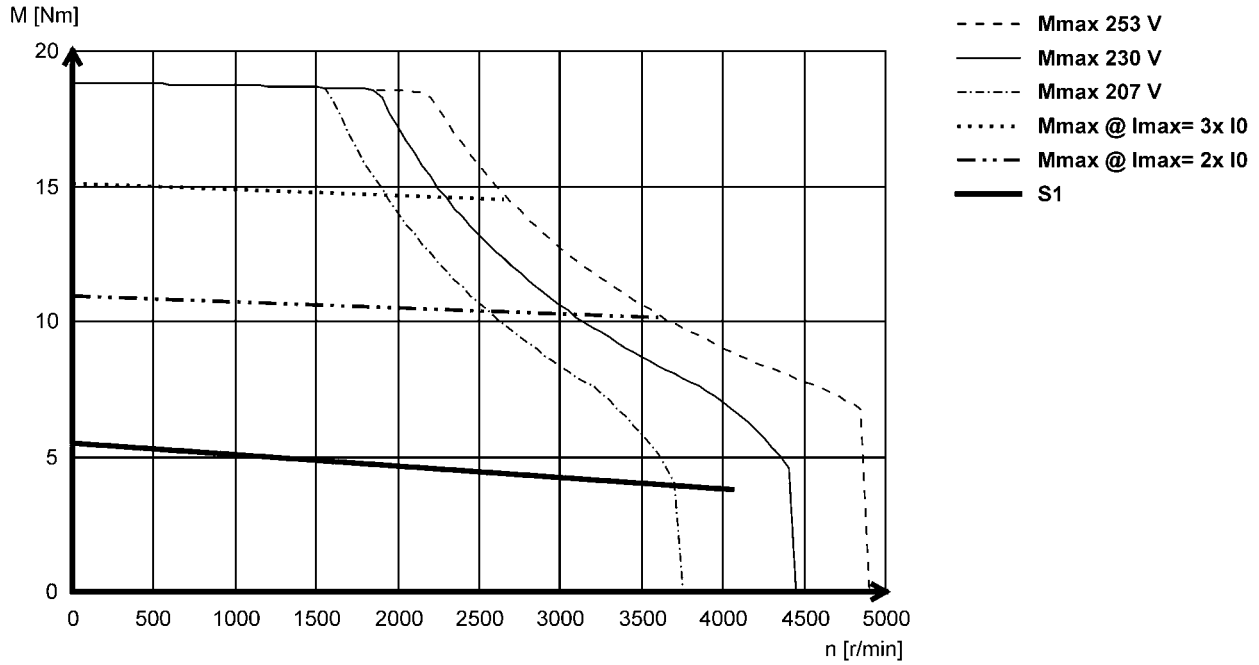

### MCS09H60L

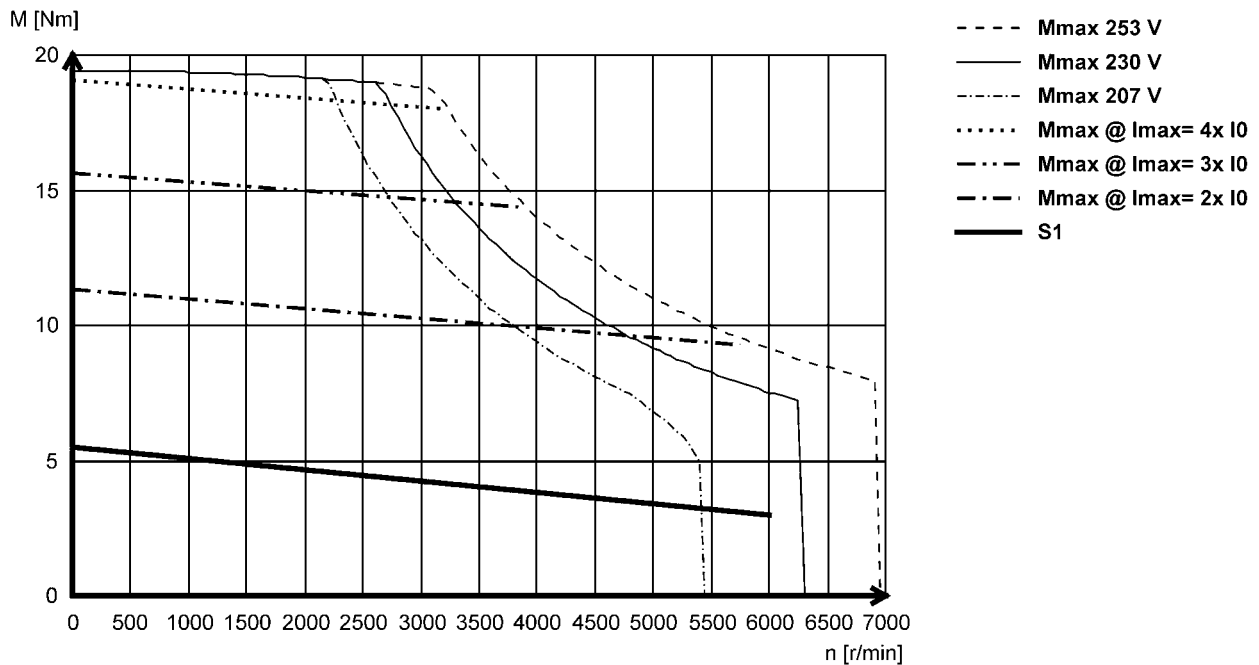

► Other torque characteristics with Lenze inverters can be found at [www.lenze.de/dsc](http://www.lenze.de/dsc).

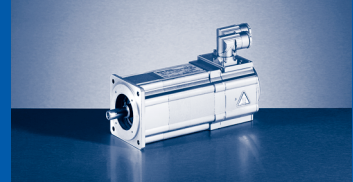

Mains connection 3x 230 V

MCS09L41L

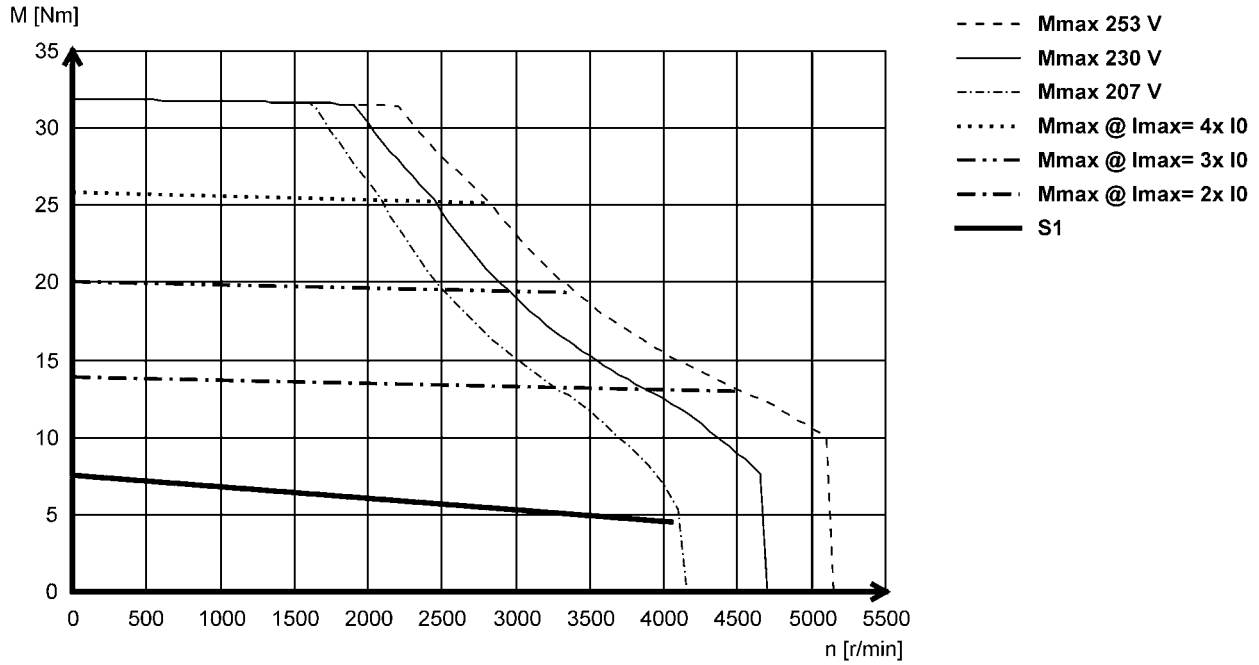

► Other torque characteristics with Lenze inverters can be found at [www.lenze.de/dsc](http://www.lenze.de/dsc).

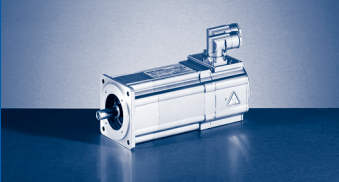

# MCS synchronous servo motors

## Torque characteristics

Mains connection 3x 230 V

### MCS12D20L

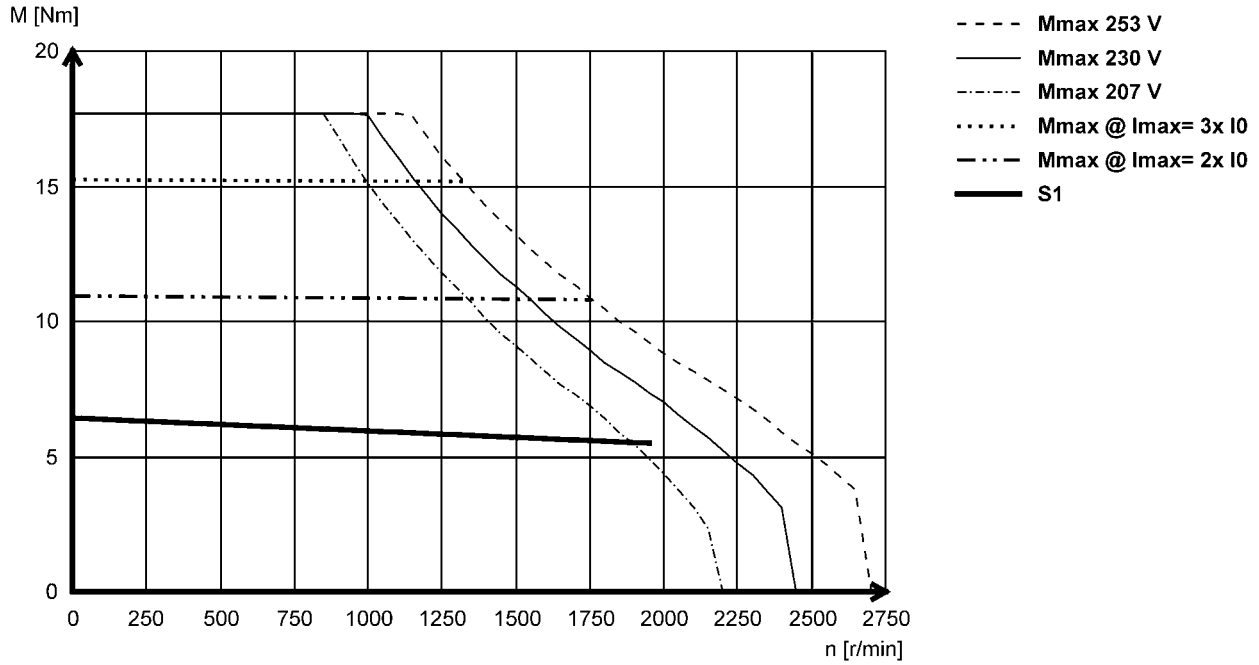

### MCS12D41L

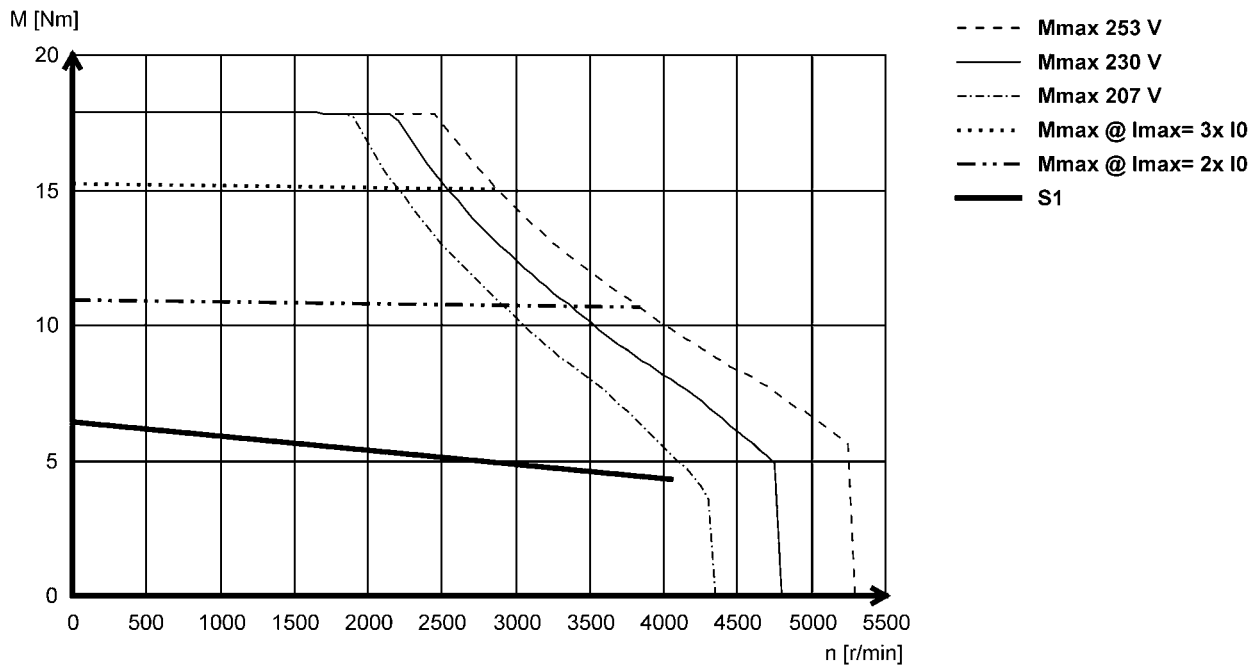

► Other torque characteristics with Lenze inverters can be found at [www.lenze.de/dsc](http://www.lenze.de/dsc).



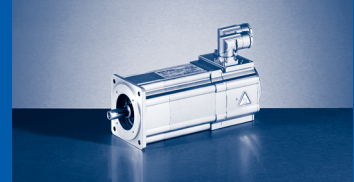

Mains connection 3x 230 V

MCS12H15L

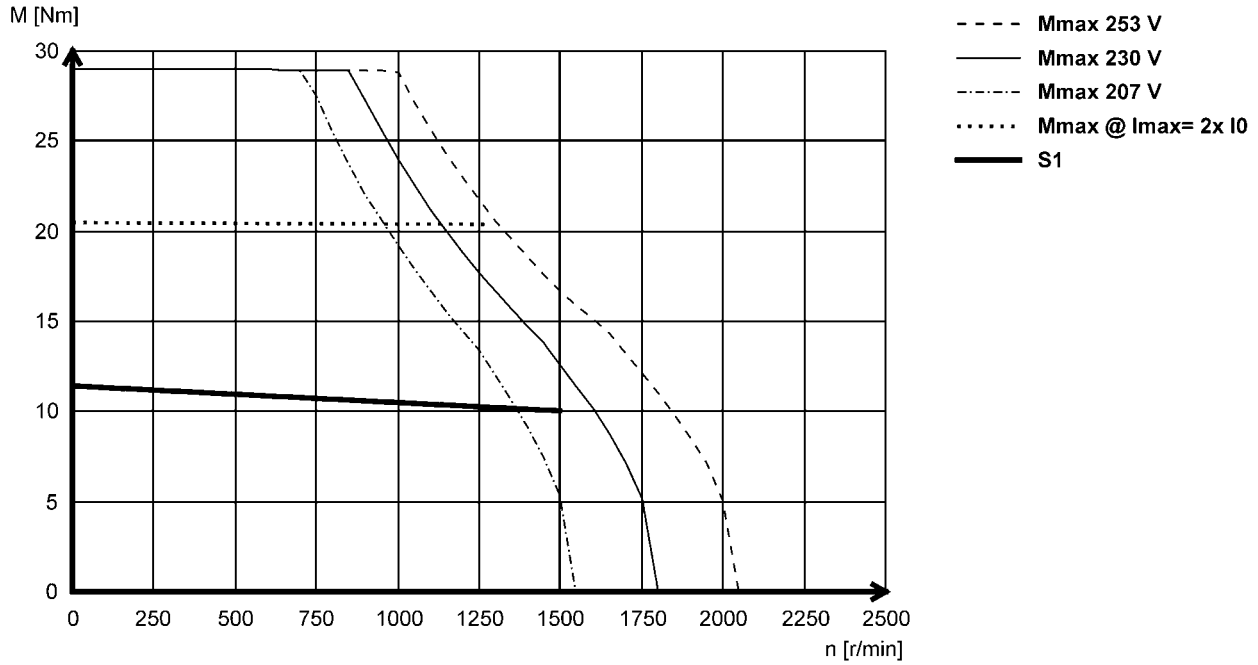

MCS12H30L

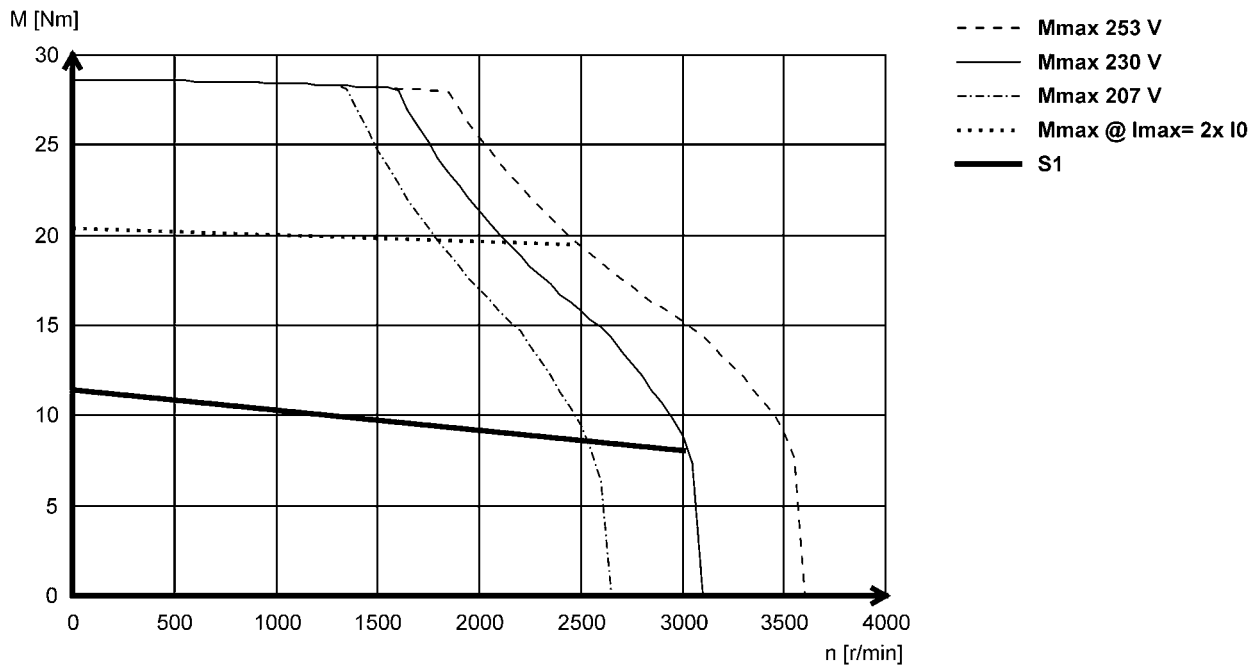

► Other torque characteristics with Lenze inverters can be found at [www.lenze.de/dsc](http://www.lenze.de/dsc).

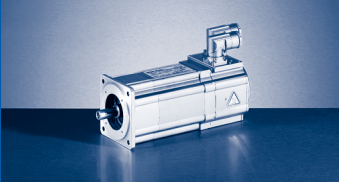

# MCS synchronous servo motors

## Torque characteristics

Mains connection 3x 230 V

MCS12L20L

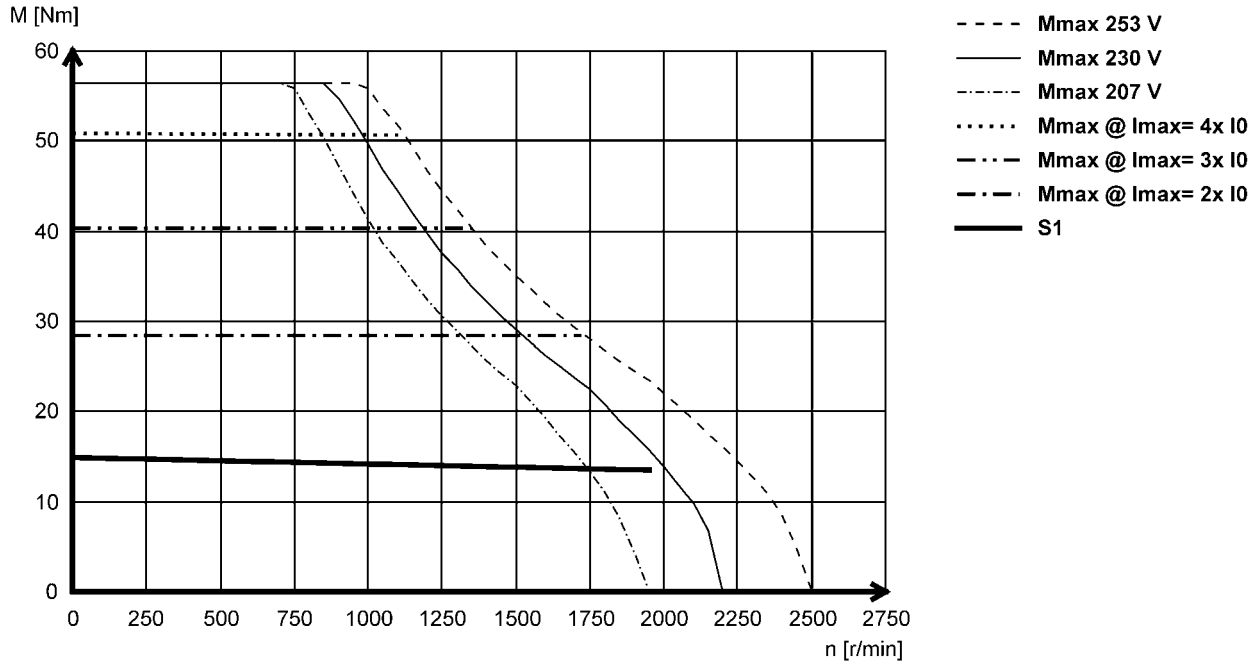

► Other torque characteristics with Lenze inverters can be found at [www.lenze.de/dsc](http://www.lenze.de/dsc).

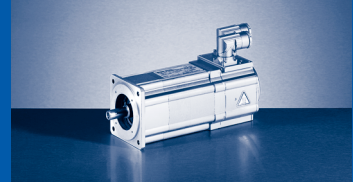

### Motor connection terminal box

If a servo motor is to be connected to an existing cable or plug connectors are not to be used for other reasons, the connection can also be made via a terminal box.

The terminals are designed as tension spring terminals to ensure here the long-term vibration resistance of the cable contacts with adequate contact pressure required.

The terminal boxes have generously dimensioned space for the customer's own wiring and large surface shield connection areas to ensure a secure EMC-compliant connection. The cable outlet may be to the left or to the right, depending on requirements.

It is not possible to attach a terminal box to the MCS06 or to models with the blower.

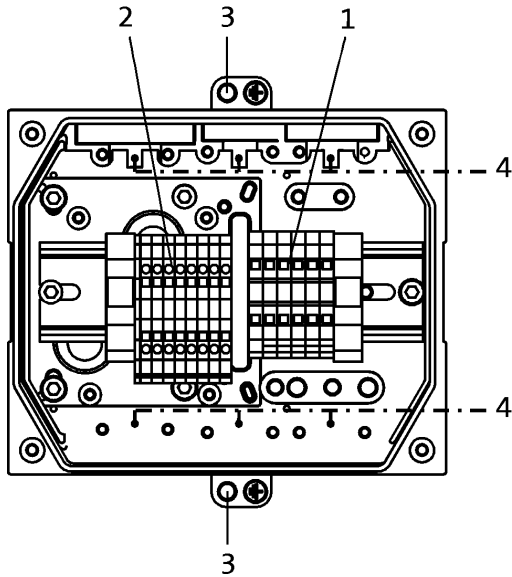

1: Power connection (terminals loadable up to 65 A) + brake connection.

2: Angle/speed sensor connection + thermal sensor connection.

3: PE connection.

4: Large area shield contact.

5: Openings for 2x M32, 2x M25, 2x M20 fittings. The openings are plugged and can be opened up as required by the customer.

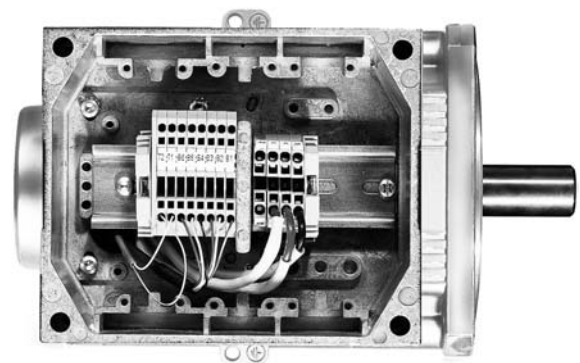

3

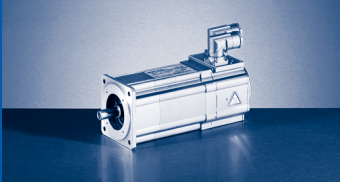

## MCS synchronous servo motors

### Accessories

#### Holding brakes

The MCS synchronous servo motors can be equipped with integral permanent magnet holding brakes for 24 V DC. The brakes are active once the supply voltage is switched off (closed-circuit principle). Where the brakes are used purely as holding brakes, there is practically no wear on the friction surfaces.

**With traversing axes**, maintaining the permissible mass inertia ratio  $J_L/J_{MB}$  ensures that the permissible maximum switching energy of the brake is not exceeded and at least 2000 emergency stop functions are possible when running at a speed of 3000 r/min.

**With lifting axes**, the load torque resulting from the force due to weight comes into play as an additional factor. In this case, the data specified for  $J_L/J_{MB}$  does not apply.

#### Caution:

**The brakes used are not safety brakes in the sense that a reduction in torque may arise as a result of disruptive factors that cannot be influenced, e.g. oil ingress.**

The ohmic voltage drop along the cable must be taken into consideration in long motor supply cables and must be compensated for by a higher voltage at the line input.

The following applies for Lenze system cables:

$$U[V] = U_B[V] + 0.08 \frac{[V]}{[A] \cdot [m]} \cdot I_L[m] \cdot I_B[A]$$

If no suitable voltage (incorrect value, incorrect polarity) is applied to the brake, the brake will be applied and can be overheated and destroyed by the motor continuing to rotate. The shortest switching times of the brakes are achieved by DC switching of the voltage. A spark suppressor is required to suppress interference and to increase the service life of the relay contacts here.



*Permanent magnet holding brake*

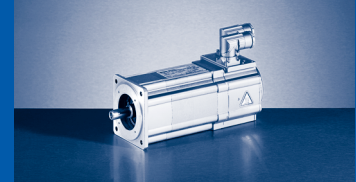

### Holding brake data

	$U_{N,DC}^{3,5)}$	$M_N$	$M_N$	$M_{av}$	$I_N^{2)}$	$J$	$t_1^{1)}$	$t_2^{1)}$	$Q_E^{4)}$	$m$	$J_{MB}$	$J_L / J_{MB}$
		20 °C	120 °C	120 °C								
	[V]	[Nm]	[Nm]	[Nm]	[A]	[kgcm <sup>2</sup> ]	[ms]	[ms]	[J]	[kg]	[kgcm <sup>2</sup> ]	
<b>MCS06C</b>	24	2.20	2.00	0.60	0.34	0.12	15.0	30.0	30.0	0.30	0.26	22.1
<b>MCS06F</b>											0.34	16.6
<b>MCS06I</b>											0.42	13.3
<b>MCS09D</b>		8.00	6.00	4.50	0.65	1.07	20.0	40.0	400	0.80	2.17	36.4
<b>MCS09F</b>											2.57	30.5
<b>MCS09H</b>											2.97	26.3
<b>MCS09L</b>											3.87	19.9
<b>MCS12D</b>		12.0	10.0	7.00	0.71	3.13	16.0	90.0	890	1.20	5.07	15.0
<b>MCS12H</b>											8.40	8.70
<b>MCS12L</b>											11.7	5.90
<b>MCS14D</b>		22.0	18.0	8.00	0.88	3.20	15.0	150	640	1.90	11.3	10.5
<b>MCS14H</b>											17.4	6.50
<b>MCS14L</b>											26.6	3.90
<b>MCS14P</b>											37.9	2.40
<b>MCS19F</b>		37.0	32.0	15.0	0.93	12.4	96.0	113	2350	3.10	77.4	5.20

### Holding brake data, reinforced design

	$U_{N,DC}^{3,5)}$	$M_N$	$M_N$	$M_{av}$	$I_N^{2)}$	$J$	$t_1^{1)}$	$t_2^{1)}$	$Q_E^{4)}$	$m$	$J_{MB}$	$J_L / J_{MB}$
		20 °C	120 °C	120 °C								
	[V]	[Nm]	[Nm]	[Nm]	[A]	[kgcm <sup>2</sup> ]	[ms]	[ms]	[J]	[kg]	[kgcm <sup>2</sup> ]	
<b>MCS09D</b>	24	12.0	10.0	7.00	0.65	1.07	20.0	40.0	400	0.80	2.17	36.4
<b>MCS09F</b>											2.57	30.5
<b>MCS09H</b>											2.97	26.3
<b>MCS09L</b>											3.87	19.9
<b>MCS12D</b>		24.0	19.0	12.0	0.71	3.13	16.0	90.0	890	1.20	7.10	24.3
<b>MCS12H</b>											10.4	16.3
<b>MCS12L</b>											13.7	12.1
<b>MCS14D</b>		37.0	32.0	15.0	0.93	12.4	96.0	113	2350	3.10	20.5	22.2
<b>MCS14H</b>											26.6	16.9
<b>MCS14L</b>											35.8	12.3
<b>MCS14P</b>											47.1	9.10
<b>MCS19J</b>		100	80.0	43.0	1.29	30.0	30.0	90.0	2100	4.30	135	2.20
<b>MCS19P</b>											190	1.20

- 1) Engagement and disengagement times are valid for rated voltage ( $\pm 0\%$ ) and protective circuit for brakes with varistor for DC switching. The times may increase without a protective circuit.
- 2) The currents are the maximum values when the brake is cold (value used for dimensioning the current supply). The values for a motor at operating temperature are considerably lower.
- 3) With 24V DC brake: smoothed DC voltage, ripple  $\leq 1\%$ .
- 4) Maximum switching energy per emergency stop at  $n = 3000$  r/min for at least 2000 emergency stops.
- 5) Voltage tolerance:  $-10\% \dots +5\%$

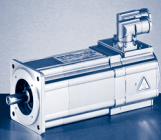

# MCS synchronous servo motors

## Accessories

### Blower data 50 Hz

		Enclosure	Number of phases					
				$U_{min}$	$U_{max}$	$U_{N, AC}$	$P_N$	$I_N$
				[V]	[V]	[V]	[kW]	[A]
MCS12	F10	IP54	1	210	240	230	0.019	0.12
	F50			104	122	115	0.018	0.22
MCS14	F10			210	240	230	0.040	0.25
	F50			104	122	115		0.53
MCS19	F10			210	240	230	0.060	0.26
	F50			104	122	115	0.047	0.45

### Blower data 60 Hz

		Enclosure	Number of phases					
				$U_{min}$	$U_{max}$	$U_{N, AC}$	$P_N$	$I_N$
				[V]	[V]	[V]	[kW]	[A]
MCS12	F10	IP54	1	210	240	230	0.019	0.12
	F50			104	122	115	0.018	0.22
MCS14	F10			210	240	230	0.040	0.25
	F50			104	122	115		0.53
MCS19	F10			210	240	230	0.060	0.26
	F50			104	122	115	0.047	0.45

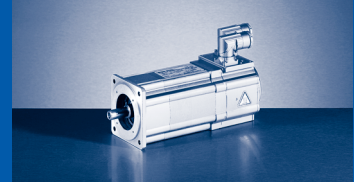

Tailored to meet the requirements of the various applications and necessary accuracies, the following feedback systems are available.

### Resolver

Stator-fed resolver with two stator windings offset by 90° and one rotor winding with transformer winding.

<b>Speed/angle sensor</b>	<sup>1)</sup>			<b>RS0</b>
<b>Resolution</b>			[°]	0.80
Angle			[°]	-10 ... 10
<b>Accuracy</b>			[°]	-10 ... 10
<b>Absolute positioning</b>				1 revolution
<b>Max. speed</b>	$n_{max}$		[r/min]	8000
<b>Max. input voltage</b>	$U_{in,max}$		[V]	10.0
DC				
<b>Max. input frequency</b>	$f_{in,max}$		[kHz]	4.00
<b>Ratio</b>		$\pm 5\%$		0.30
Stator / rotor				
<b>Rotor impedance</b>	$Z_{ro}$		[Ω]	51 + j90
<b>Stator impedance</b>	$Z_{so}$		[Ω]	102 + j150
<b>Impedance</b>	$Z_{rs}$		[Ω]	44 + j76
<b>Min. insulation resistance</b>	$R$		[MΩ]	10.0
At DC 500 V				
<b>Number of pole pairs</b>				1
<b>Max. angle error</b>			[°]	-10 ... 10
<b>Inverter assignment</b>				E84AVTC E94A ECS EVS93

<sup>1)</sup> →  14 - Product key > speed/angle sensor

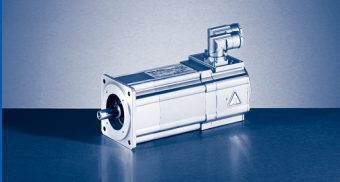

# MCS synchronous servo motors

## Accessories

### Incremental encoder and SinCos absolute value encoder

Encoder type			TTL incremental	SinCos absolute value				
Speed/angle sensor	1)		C40	EQI	SRS	SRM	ECN	EQN
			IK4096-5V-T	AM32-5V-E	AS1024-8V-H	AM1024-8V-H	AS2048-5V-E	AM2048-5V-E
Encoder type			Single-turn	Multi-turn	Single-turn	Multi-turn	Single-turn	Multi-turn
Pulses			4096	32	1024		2048	
Output signals			TTL	1 V <sub>ss</sub>				
Interfaces				EnDat	Hiperface		EnDat	
Absolute revolutions			0	4096	1	4096	1	4096
Resolution Angle <sup>2)</sup>		[°]	1.30	0.40				
Accuracy		[°]	-1 ... 1	-5 ... 5	-0.8 ... 0.8		-0.6 ... 0.6	
Min. input voltage DC	$U_{in,min}$	[V]	4.50	4.75	7.00		4.75	
Max. input voltage DC	$U_{in,max}$	[V]	5.50	5.25	12.0		5.25	
Max. speed	$n_{max}$	[r/min]	7324	12000	6000		12000	
Max. current consumption	$I_{max}$	[A]	0.075	0.17	0.080		0.15	0.25
Limit frequency	$f_{max}$	[kHz]	500	6.00	200			
Inverter assignment			E94P	E94A	E84AVTC E94A ECS EVS93		E94A	

1) →  14 - Product key > speed/angle sensor

2) Dependent on inverter.



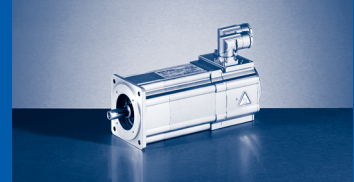

### Thermal sensor

The thermal sensors used in the MCS motors monitor the motor temperature continuously. The temperature signal is transmitted over the system cable of the feedback system to the servo controller. Because of the different physical conditions, there are two temperature monitoring mechanisms on the MCS motors (there is no complete motor protection in either case)

#### MCS06

On this motor, the winding temperature of one winding phase is monitored with a KTY 83-110 type thermal sensor.

#### MCS09 ... 19

These motors are monitored by three thermal sensors (1x KTY 83-110 + 2x PTC 150 °C) connected in series. This means that the temperature of the motor is determined with great accuracy in the permitted operating range and at the same time the overtemperature response configured in the controller is executed in the event of overtemperature in one of the winding phases.

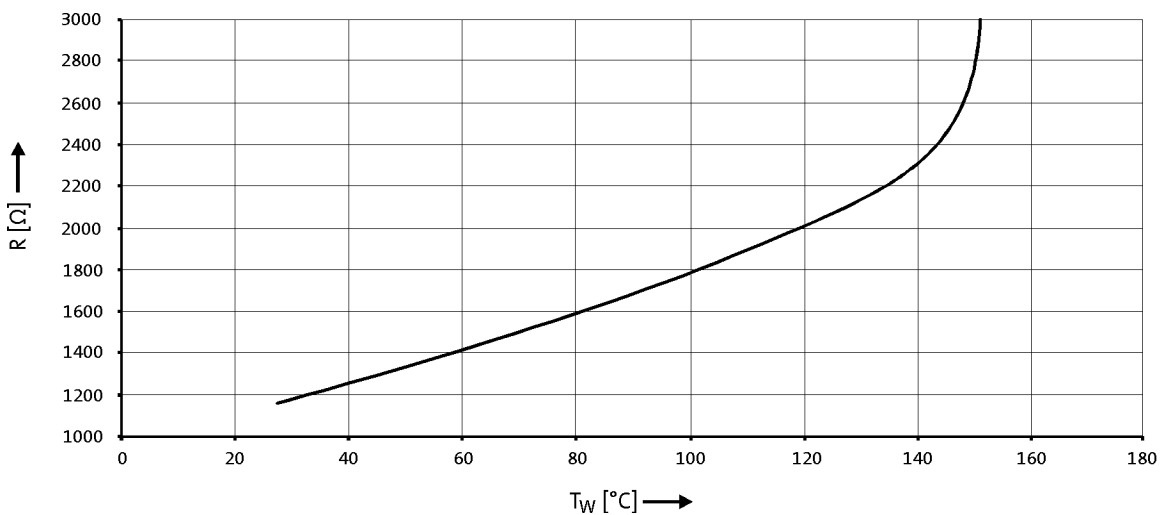

- If the detector is supplied with a measured current of 1 mA, the above relationship between the temperature and the resistance applies.

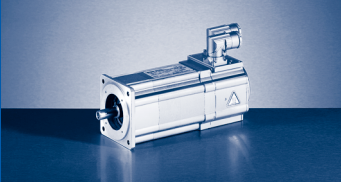

## MCS synchronous servo motors

Rated data

3

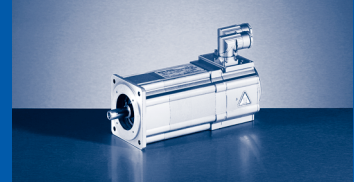

## Motors without blower

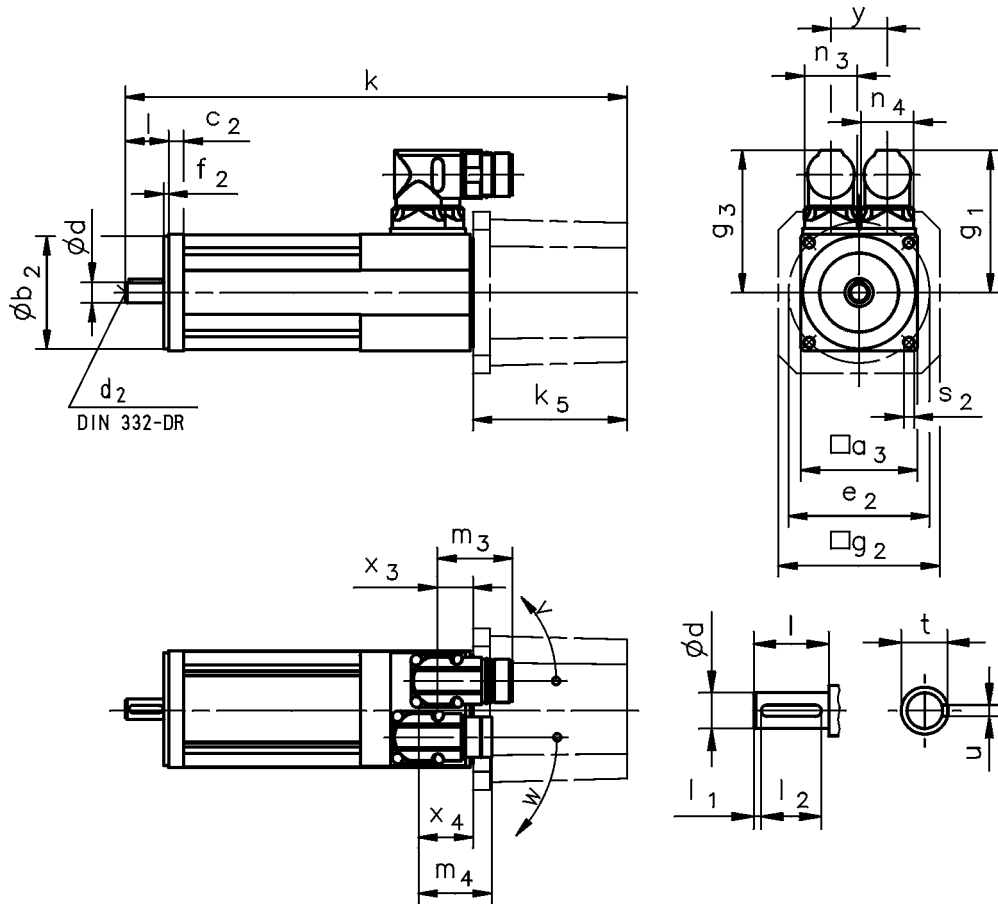

			MCS06C	MCS06F	MCS06I
RS0 / C40 B0	k	[mm]	155	185	215
RS0 / C40 P□	k	[mm]	174	204	233
SR□ / E□□ B0	k	[mm]	237	266	297
SR□ / E□□ P□	k	[mm]	255	285	315
SR□ / E□□	k <sub>5</sub>	[mm]		82	
	g <sub>2</sub>	[mm]		86	

- ▶ Speed/angle sensor: RS0 / C40 / SR□ / E□□
- ▶ Brake: B0 / P□

	g <sub>1</sub>	g <sub>3</sub>	x <sub>3</sub>	x <sub>4</sub>	m <sub>3</sub>	m <sub>4</sub>	n <sub>3</sub>	n <sub>4</sub>	y	v	w
	[mm]	[mm]	[mm]	[mm]	[mm]	[mm]	[mm]	[mm]	[mm]	[°]	[°]
<b>MCS06</b>	77	77	19	29	40	40	28	28	30	190	230
	d	d <sub>2</sub>	l	l <sub>1</sub>	l <sub>2</sub>	u	t				
	k <sub>6</sub>		-0.7 ... 0.3								
	[mm]	[mm]		[mm]	[mm]	[mm]	[mm]				
<b>MCS06</b>	11	M4	23	2.0	18	4.0	13				
	a <sub>3</sub>	b <sub>2</sub>	c <sub>2</sub>	e <sub>2</sub>	f <sub>2</sub>	s <sub>2</sub>					
	j <sub>6</sub>										
	[mm]	[mm]	[mm]	[mm]	[mm]	[mm]					
<b>MCS06</b>	62	60	8	75	2.5	5.5					

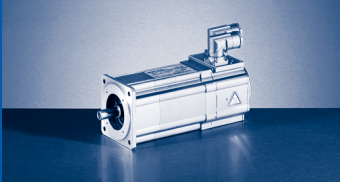

# MCS synchronous servo motors

Dimensions [mm]

## Motors without blower

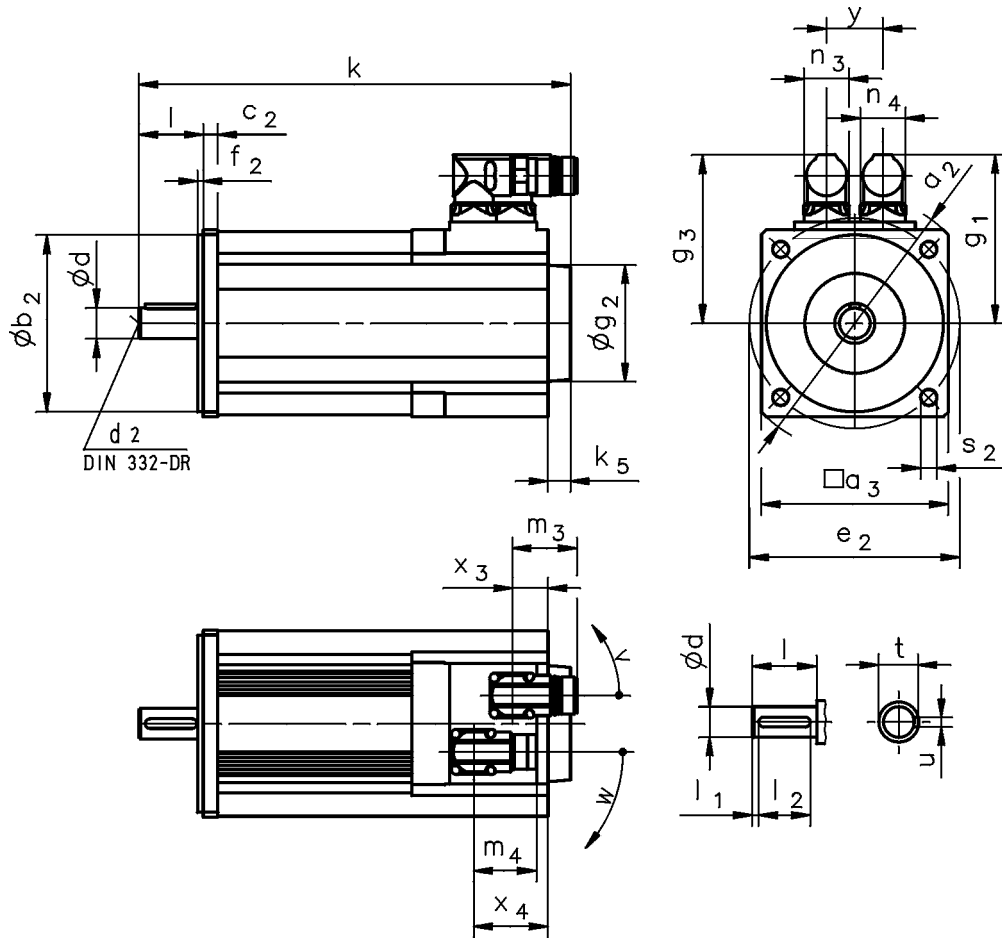

			MCS09D	MCS09F	MCS09H	MCS09L	MCS12D	MCS12H	MCS12L
RS0 / C40 B0	k	[mm]	213	233	253	293	228	268	308
RS0 / C40 P□	k	[mm]	233	253	273	313	248	288	328
RS0 / C40	k <sub>5</sub>	[mm]	13					14	
	g <sub>2</sub>	[mm]	67					72	
SR□ / E□□ B0	k	[mm]	264	284	304	344	277	317	357
SR□ / E□□ P□	k	[mm]	284	304	324	364	297	337	377
SR□ / E□□	k <sub>5</sub>	[mm]	64					63	
	g <sub>2</sub>	[mm]	81					89	
			MCS14D	MCS14H	MCS14L	MCS14P	MCS19F	MCS19J	MCS19P
RS0 / C40 B0	k	[mm]	251	291	331	371	280	320	380
RS0 / C40 P□	k	[mm]	279	319	359	399	314	364	424
RS0 / C40	k <sub>5</sub>	[mm]	24					15	
	g <sub>2</sub>	[mm]				78			
SR□ / E□□ B0	k	[mm]	301	341	381	421	329	369	429
SR□ / E□□ P□	k	[mm]	329	369	409	449	363	413	473
SR□ / E□□	k <sub>5</sub>	[mm]	74					64	
	g <sub>2</sub>	[mm]				101			

- ▶ Speed/angle sensor: RS0 / C40 / SR□ / E□□
- ▶ Brake: B0 / P□

# MCS synchronous servo motors

## Dimensions [mm]

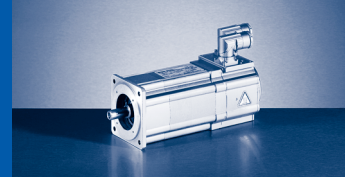

3

	$g_1$	$g_3$	$x_3$	$x_4$	$m_3$	$m_4$	$n_3$	$n_4$	$y$	$v$	$w$
	[mm]	[mm]	[mm]	[mm]	[mm]	[mm]	[mm]	[mm]	[mm]	[°]	[°]
MCS09	90	90	20	44	40	40	28	28	35	195	260
MCS12	105	105	22	46							

	$g_1$	$g_3$	$x_3$	$x_4$	$m_3$	$m_4$	$n_3$	$n_4$	$y$	$v$	$w$	
	[mm]	[mm]	[mm]	[mm]	[mm]	[mm]	[mm]	[mm]	[mm]	[°]	[°]	
MCS14D15-	117	117	24	48	40	40	28	28	35	195	260	
MCS14D36-												
MCS14H15-												
MCS14H32-												
MCS14L15-												
MCS14L32-	146	126	29	36		75				45	180	205
MCS14P14-	117	117	24	48		40				28	195	260
MCS14P32-	146	126	29	36		75				45	180	205
MCS19F14-	142	142	24 51 <sup>1)</sup>	48 75 <sup>1)</sup>		40				28	195	260
MCS19F30-	171	151	29 56 <sup>1)</sup>	36 63 <sup>1)</sup>		75				45	180	205
MCS19J14-	142	142	24 51 <sup>1)</sup>	48 75 <sup>1)</sup>	40	28	195	260				
MCS19J30-	171	151	29 56 <sup>1)</sup>	36 63 <sup>1)</sup>	75	45	180	205				
MCS19P14-	142	142	24 51 <sup>1)</sup>	48 75 <sup>1)</sup>	40	28	195	260				
MCS19P30-	171	151	29 56 <sup>1)</sup>	36 63 <sup>1)</sup>	75	45	180	205				

	$d$	$d_2$	$l$	$l_1$	$l_2$	$u$	$t$
	k6		-0.7 ... 0.3				
	[mm]	[mm]		[mm]	[mm]	[mm]	[mm]
MCS09	14	M5	30	2.5	25	5.0	16
MCS12	19	M6	40	4.0	32	6.0	22
MCS14	24	M8	50	5.0	40	8.0	27
MCS19	28	M10	60		50		31

	$a_2$	$a_3$	$b_2$	$c_2$	$e_2$	$f_2$	$s_2$
			j6				
	[mm]	[mm]	[mm]	[mm]	[mm]	[mm]	[mm]
MCS09	120	89	80	8	100	3.0	7.0
MCS12	160	116	110	9	130	3.5	10.0
MCS14	188	143	130	13	165		12.0
MCS19	250	192	180	11	215	4.0	14.0

<sup>1)</sup> On version with brake (P□)

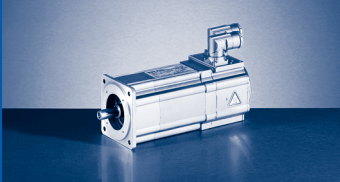

# MCS synchronous servo motors

## Dimensions [mm]

### Motors with blower

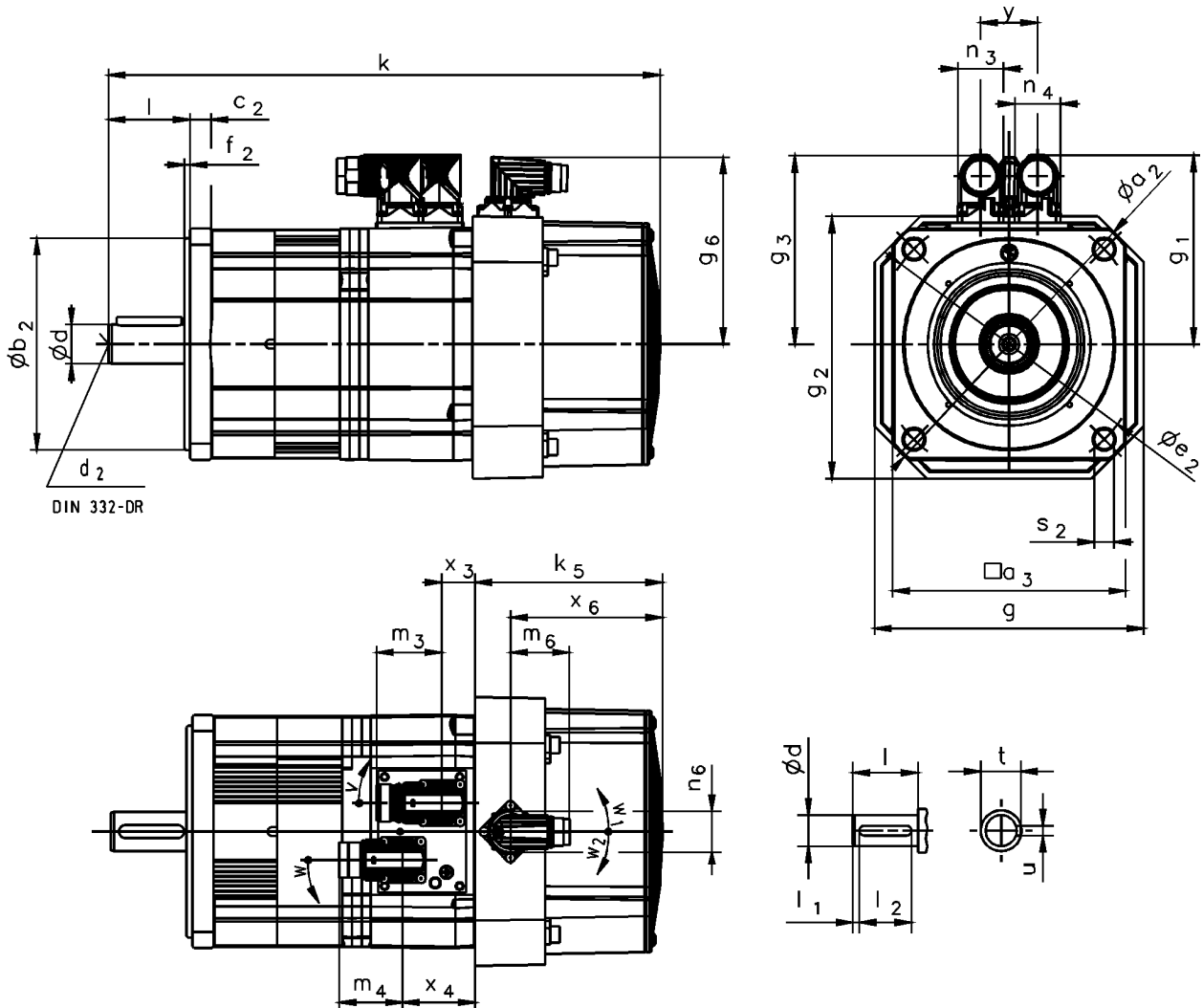

DIN 332-DR

			MCS12D	MCS12H	MCS12L	MCS14D	MCS14H	MCS14L	MCS14P	MCS19F	MCS19J	MCS19P
RS0 / C40 B0	k	[mm]	301	341	381	339	379	419	459	387	427	487
RS0 / C40 P□	k	[mm]	321	361	401	368	408	448	488	421	471	531
RS0 / C40	k <sub>5</sub>	[mm]	92			115			126			
SR□ / E□□ B0	k	[mm]	344	384	424	392	432	472	512	425	465	525
SR□ / E□□ P□	k	[mm]	364	404	444	421	461	501	541	459	509	569
SR□ / E□□	k <sub>5</sub>	[mm]	135			169			165			
	g	[mm]	140			167			212			
	g <sub>2</sub>	[mm]	140			163			210			

- ▶ Speed/angle sensor: RS0 / C40 / SR□ / E□□
- ▶ Brake: B0 / P□

# MCS synchronous servo motors

## Dimensions [mm]

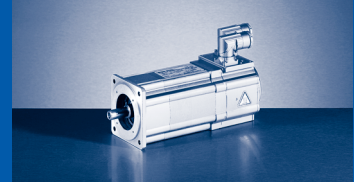

3

	g <sub>1</sub>	g <sub>3</sub>	g <sub>6</sub>	x <sub>3</sub>	x <sub>4</sub>	x <sub>6</sub>	m <sub>3</sub>	m <sub>4</sub>	m <sub>6</sub>	n <sub>3</sub>	n <sub>4</sub>	n <sub>6</sub>	y	v	w	w <sub>1</sub>	w <sub>2</sub>	
	[mm]	[mm]	[mm]	[mm]	[mm]	[mm]	[mm]	[mm]	[mm]	[mm]	[mm]	[mm]	[mm]	[°]	[°]	[°]	[°]	
MCS12D17	105	105	107	16	40	67		40			28							
MCS12D35																		
MCS12H14																		
MCS12H34																		
MCS12L17																		
MCS12L39																		
MCS14D14	117	117	115	20	44	93	40	40	37	28	45	28	35	160	160	120	130	
MCS14D30																		
MCS14H12																		
MCS14H28																		
MCS14L14																		
MCS14L30																		
MCS14P11	146	126	142	19	43	96	75	75			28							
MCS14P26																		
MCS19F12																		
MCS19F29																		
MCS19J12																		
MCS19J29																		
MCS19P12	171	151	142	24	31	96	75	75			45							
MCS19P29																		

	d	d <sub>2</sub>	l	l <sub>1</sub>	l <sub>2</sub>	u	t
	k6		-0.7 ... 0.3				
	[mm]	[mm]		[mm]	[mm]	[mm]	[mm]
MCS12	19	M6	40	4.0	32	6.0	22
MCS14	24	M8	50	5.0	40	8.0	27
MCS19	28	M10	60		50		31

	a <sub>2</sub>	a <sub>3</sub>	b <sub>2</sub>	c <sub>2</sub>	e <sub>2</sub>	f <sub>2</sub>	s <sub>2</sub>
			j6				
	[mm]	[mm]	[mm]	[mm]	[mm]	[mm]	[mm]
MCS12	160	116	110	9	130	3.5	10.0
MCS14	188	143	130	13	165		12.0
MCS19	250	192	180	11	215	4.0	14.0

<sup>1)</sup> On version with brake (P□)

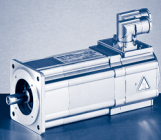

# MCS synchronous servo motors

Dimensions [mm]

## Motors with terminal box

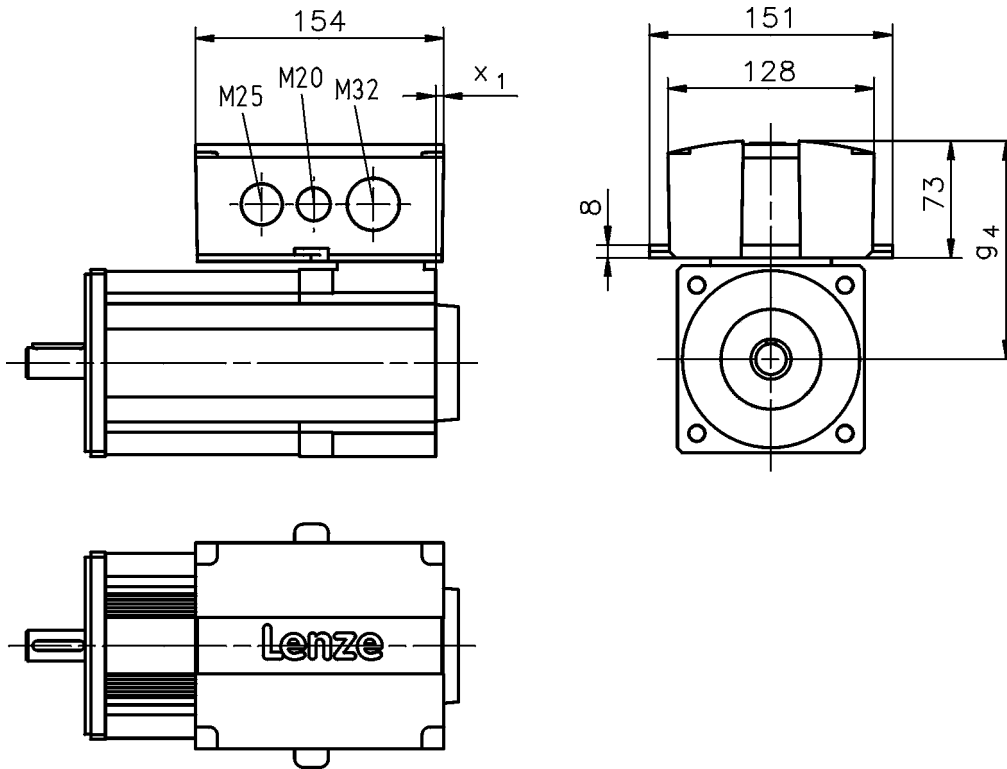

	g <sub>4</sub>	x <sub>1</sub>
	[mm]	[mm]
MCS09	121	8
MCS12	136	5
MCS14	147	3
MCS19	172	



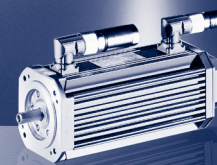

### Mains connection 3x 400 V

	$n_N$	$M_0$	$M_{max}$	$M_N$	$P_N$	$I_0$	$I_N$	$I_{max}$	$U_{N, AC}$	$f_N$
	[r/min]	[Nm]	[Nm]	[Nm]	[kW]	[A]	[A]	[A]	[V]	[Hz]
<b>MDSKS□□056-23</b>	3800	3.20	11.6	2.80	1.10	2.60	2.30	10.0	330	190
<b>MDSKS□□056-33</b>	4000	4.70	17.2	4.20	1.80	4.00	3.60	16.0	325	200
<b>MDSKS□□071-03</b>	3400	6.70	23.6	5.70	2.00	4.90	4.20	19.0	330	170
<b>MDSKS□□071-13</b>	3700	10.0	35.2	8.30	3.20	8.40	7.00	32.0	325	185
<b>MDSKS□□071-33</b>	3600	14.7	52.0	12.3	4.60	11.9	10.0	45.0	325	180
<b>MDFKS□□071-03</b>	3300	8.80	23.6	7.50	2.60	6.60	5.60	19.0	330	165
<b>MDFKS□□071-13</b>	3600	13.3	35.2	11.0	4.10	11.1	9.20	32.0	325	180
<b>MDFKS□□071-33</b>	3500	19.3	52.0	16.2	5.90	15.6	13.1	45.0	325	175

	$\eta_{100\%}$	$J^1)$	$KE_{LL 150\text{ °C}}$	$R_{UV 20\text{ °C}}$	$R_{UV 150\text{ °C}}$	$L_N$	$Kt_{0 150\text{ °C}}$	$n_{max}^2)$	$m^1)$
	[%]	[kgcm <sup>2</sup> ]	[V / 1000 rp]	[Ω]	[Ω]	[mH]	[Nm/A]	[r/min]	[kg]
<b>MDSKS□□056-23</b>	85	1.20	78.1	10.1	13.6	17.1	1.23	5500	5.30
<b>MDSKS□□056-33</b>	87	1.80	74.6	5.10	6.90	10.8	1.18	5500	6.30
<b>MDSKS□□071-03</b>	85	6.00	93.0	3.40	4.60	10.6	1.37	5000	8.90
<b>MDSKS□□071-13</b>	82	8.00	84.5	1.50	2.10	5.30	1.19	5000	10.9
<b>MDSKS□□071-33</b>	82	10.0	88.2	1.10	1.60	5.80	1.24	5000	13.0
<b>MDFKS□□071-03</b>	81	6.00	93.0	3.40	4.60	10.6	1.33	5000	10.2
<b>MDFKS□□071-13</b>	79	8.00	84.5	1.50	2.10	5.30	1.20	5000	12.2
<b>MDFKS□□071-33</b>	80	10.0	88.2	1.10	1.60	5.80	1.24	5000	12.2

<sup>1)</sup> Without brake.

<sup>2)</sup> Mechanically permissible maximum speed.

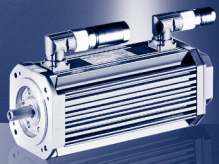

# MDKS synchronous servo motors

## Rated data

### Permissible radial and axial forces

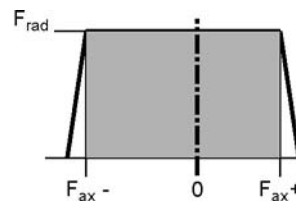
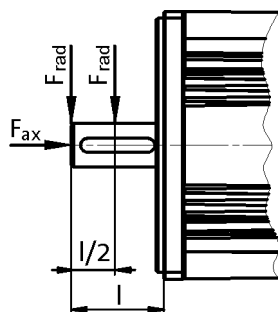

#### Application of force at l/2

	Bearing service life $L_{10}$														
	5000 h			10000 h			20000 h			30000 h			50000 h		
	$F_{rad}$	$F_{ax,-}$	$F_{ax,+}$	$F_{rad}$	$F_{ax,-}$	$F_{ax,+}$	$F_{rad}$	$F_{ax,-}$	$F_{ax,+}$	$F_{rad}$	$F_{ax,-}$	$F_{ax,+}$	$F_{rad}$	$F_{ax,-}$	$F_{ax,+}$
	[N]	[N]	[N]	[N]	[N]	[N]	[N]	[N]	[N]	[N]	[N]	[N]	[N]	[N]	[N]
MDSKS□□056	590	-90	280	470	-40	230	370	0	190	310	10	180	220	10	180
MDSKS□□071	910	-50	520	700	20	450	430	20	450		20	450	50	-50	520
MDFKS□□071															

#### Application of force at l

	Bearing service life $L_{10}$														
	5000 h			10000 h			20000 h			30000 h			50000 h		
	$F_{rad}$	$F_{ax,-}$	$F_{ax,+}$	$F_{rad}$	$F_{ax,-}$	$F_{ax,+}$	$F_{rad}$	$F_{ax,-}$	$F_{ax,+}$	$F_{rad}$	$F_{ax,-}$	$F_{ax,+}$	$F_{rad}$	$F_{ax,-}$	$F_{ax,+}$
	[N]	[N]	[N]	[N]	[N]	[N]	[N]	[N]	[N]	[N]	[N]	[N]	[N]	[N]	[N]
MDSKS□□056	550	-90	280	430	-40	230	340	0	190	290	10	180	200	10	180
MDSKS□□071	820	-50	520	630	20	450	390	20	450	280	20	450	40	-50	520
MDFKS□□071															

- The values for the bearing service life  $L_{10}$  refer to an average speed of 4000 r/min. Depending on the ambient temperatures, the service life of the bearings is also reduced by the grease lifetime.

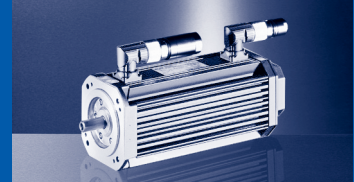

**Mains connection 3 x 400 V and switching frequency  
4 kHz**

**Motors without blower**

					E94A□□	E0024	E0034	E0044	E0074	E0094	E0134	E0174
					$I_N$	1.9	3.1	5.0	8.8	11.7	16.3	20.6
					$I_{0,max}$	6.0	10.0	16.0	21.0	28.0	39.0	49.5
MDSKS	$M_N$	$n_N$	$I_N$	$P_N$	$I_{max}$	6.0	10.0	16.0	21.0	28.0	39.0	49.5
056-23	2.8	3800	2.3	1.10	$M_0$	2.3	3.2					
					$M_N$	2.3	2.8					
					$M_{0,max}$	7.5	11.6					
					$M_{max}$	7.5	11.6					
					$n_{eto}$	-	-					
056-33	4.2	4000	3.6	1.80	$M_0$		3.6	4.7				
					$M_N$		3.6	4.2				
					$M_{0,max}$		12.0	17.2				
					$M_{max}$		12.0	17.2				
					$n_{eto}$		-	-				
071-03	5.7	3400	4.2	2.00	$M_0$		4.2	6.7	6.7			
					$M_N$		4.2	5.7	5.7			
					$M_{0,max}$		15.2	21.4	23.6			
					$M_{max}$		15.2	21.4	23.6			
					$n_{eto}$		-	-	-			
071-13	8.3	3700	7.0	3.20	$M_0$			6.0	10.0	10.0	10.0	
					$M_N$			5.9	8.3	8.3	8.3	
					$M_{0,max}$			22.0	27.1	32.7	35.2	
					$M_{max}$			22.0	27.1	32.7	35.2	
					$n_{eto}$			-	-	-	-	
071-33	12.3	3600	10.0	4.60	$M_0$				10.9	14.3	14.7	14.7
					$M_N$				10.8	12.3	12.3	12.3
					$M_{0,max}$				31.2	38.9	48.3	52.0
					$M_{max}$				31.2	38.9	48.3	52.0
					$n_{eto}$				-	-	-	-

►  $I...$  [A],  $M...$  [Nm],  $n...$  [r/min],  $P...$  [kW]

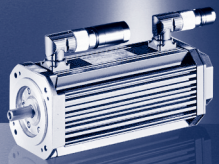

## MD□KS synchronous servo motors

### 9400 Servo Drives selection tables

Mains connection 3 x 400 V and switching frequency  
4 kHz

#### Motors with blower

					E94A□□	E0044	E0074	E0094	E0134	E0174
					$I_N$	5.0	8.8	11.7	16.3	20.6
					$I_{0,max}$	16.0	21.0	28.0	39.0	49.5
MDFKS	$M_N$	$n_N$	$I_N$	$P_N$	$I_{max}$	16.0	21.0	28.0	39.0	49.5
071-03	7.5	3300	5.6	2.60	$M_0$	6.7	8.8			
					$M_N$	6.7	7.5			
					$M_{0,max}$	21.6	23.6			
					$M_{max}$	21.6	23.6			
					$n_{eto}$	-	-			
071-13	11.0	3600	9.2	4.10	$M_0$		10.5	13.3	13.3	
					$M_N$		10.5	11.0	11.0	
					$M_{0,max}$		27.8	33.1	35.2	
					$M_{max}$		27.8	33.1	35.2	
					$n_{eto}$		-	-	-	
071-33	16.2	3500	13.1	5.90	$M_0$			14.4	19.3	19.3
					$M_N$			14.3	16.2	16.2
					$M_{0,max}$			40.0	48.8	52.0
					$M_{max}$			40.0	48.8	52.0
					$n_{eto}$			-	-	-

►  $I...$  [A],  $M...$  [Nm],  $n...$  [r/min],  $P...$  [kW]

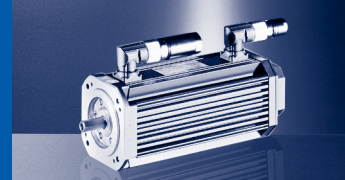

## Mains connection 3 x 400 V and switching frequency 8 kHz

### Motors without blower

					E84AVTC	□5514	□7514	□1124	□1524	□2224	□3024	□4024	□5524	□7524	□1134	□1534
					$I_N$	1.8	2.4	3.2	3.9	5.9	7.3	9.5	13.0	16.5	23.5	32.0
					$I_{0,max}$	2.7	3.6	4.8	5.9	8.4	11.0	14.3	19.5	26.4	32.9	43.2
MDSKS	$M_N$	$n_N$	$I_N$	$P_N$	$I_{max}$	3.6	4.8	6.4	7.8	11.8	14.6	19.0	26.0	33.0	47.0	64.0
056-23	2.8	3800	2.3	1.10	$M_0$	2.4	3.1	3.2	3.2	3.2	3.2					
					$M_N$	2.2	2.8	2.8	2.8	2.8	2.8					
					$M_{0,max}$	4.6	6.2	8.0	9.8	11.6	11.6					
					$M_{max}$	4.6	6.2	8.0	9.8	11.6	11.6					
					$n_{eto}$	-	-	-	-	-	-					
056-33	4.2	4000	3.6	1.80	$M_0$			4.1	4.6	4.7	4.7	4.7	4.7			
					$M_N$			3.7	4.2	4.2	4.2	4.2	4.2			
					$M_{0,max}$			8.2	10.0	14.0	17.2	16.8	17.2			
					$M_{max}$			8.2	10.0	14.0	17.2	16.8	17.2			
					$n_{eto}$			-	-	-	-	-	-			
071-03	5.7	3400	4.2	2.00	$M_0$			4.3	5.3	6.7	6.7	6.7	6.7			
					$M_N$			4.3	5.3	5.7	5.7	5.7	5.7			
					$M_{0,max}$			10.5	12.8	17.8	22.0	23.0	23.6			
					$M_{max}$			10.5	12.8	17.8	22.0	23.0	23.6			
					$n_{eto}$			-	-	-	-	-	-			
071-13	8.3	3700	7.0	3.20	$M_0$					7.0	8.7	10.0	10.0	10.0	10.0	
					$M_N$					7.0	8.7	8.3	8.3	8.3	8.3	
					$M_{0,max}$					17.4	21.6	25.0	29.3	29.3	29.3	
					$M_{max}$					17.4	21.6	25.0	34.3	35.2	35.2	
					$n_{eto}$					-	-	-	-	-	-	
071-33	12.3	3600	10.0	4.60	$M_0$							14.0	14.7	14.7	14.7	14.7
					$M_N$							11.7	12.3	12.3	12.3	12.3
					$M_{0,max}$							28.5	39.1	42.7	42.7	42.7
					$M_{max}$							28.5	39.1	52.0	52.0	52.0
					$n_{eto}$							-	-	-	-	-

►  $I...$  [A],  $M...$  [Nm],  $n...$  [r/min],  $P...$  [kW]

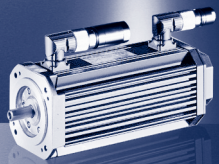

## MDKS synchronous servo motors

Selection tables for Inverter Drives 8400 TopLine

Mains connection 3 x 400 V and switching frequency  
8 kHz

### Motors with blower

					E84AVTC	□1124	□1524	□2224	□3024	□4024	□5524	□7524	□1134	□1534
					$I_N$	3.2	3.9	5.9	7.3	9.5	13.0	16.5	23.5	32.0
					$I_{0,max}$	4.8	5.9	8.4	11.0	14.3	19.5	26.4	32.9	43.2
MDFKS	$M_N$	$n_N$	$I_N$	$P_N$	$I_{max}$	6.4	7.8	11.8	14.6	19.0	26.0	33.0	47.0	64.0
071-03	7.5	3300	5.6	2.60	$M_0$	4.3	5.2	8.8	8.8	8.8	8.8			
					$M_N$	4.3	5.2	7.5	7.5	7.5	7.5			
					$M_{0,max}$	8.6	10.4	18.3	22.7	23.0	23.6			
					$M_{max}$	8.6	10.4	18.3	22.7	23.0	23.6			
					$n_{eto}$	-	-	-	-	-	-			
071-13	11.0	3600	9.2	4.10	$M_0$			7.1	8.8	13.3	13.3	13.3	13.3	
					$M_N$			7.1	8.8	11.0	11.0	11.0	11.0	
					$M_{0,max}$			14.2	17.5	25.7	29.9	29.9	29.3	
					$M_{max}$			14.2	17.5	25.7	35.2	35.2	35.2	
					$n_{eto}$			-	-	-	-	-	-	
071-33	16.2	3500	13.1	5.90	$M_0$					11.8	16.1	19.3	19.3	19.3
					$M_N$					11.8	16.1	16.2	16.2	16.2
					$M_{0,max}$					29.7	40.7	43.6	43.6	43.6
					$M_{max}$					29.7	40.7	52.0	52.0	52.0
					$n_{eto}$					-	-	-	-	-

►  $I...$  [A],  $M...$  [Nm],  $n...$  [r/min],  $P...$  [kW]

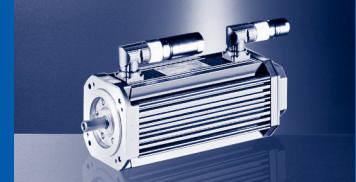

**Mains connection 3 x 400 V and switching frequency  
4 kHz**

**Motors without blower**

					ECS□□	008C□B	016C□B	032C□B	048C□B
					$I_N$	4.0	8.0	12.7	17.0
					$I_{0,max}$	4.6	9.1	18.1	27.2
MDSKS	$M_N$	$n_N$	$I_N$	$P_N$	$I_{max}$	8.0	16.0	32.0	48.0
056-23	2.8	3800	2.3	1.10	$M_0$	3.2	3.2		
					$M_N$	2.8	2.8		
					$M_{0,max}$	5.9	10.7		
					$M_{max}$	9.6	11.6		
					$n_{eto}$	2816	2452		
056-33	4.2	4000	3.6	1.80	$M_0$	4.7	4.7		
					$M_N$	4.2	4.2		
					$M_{0,max}$	5.4	11.1		
					$M_{max}$	9.9	17.2		
					$n_{eto}$	3620	2705		
071-03	5.7	3400	4.2	2.00	$M_0$	5.5	6.7		
					$M_N$	5.4	5.7		
					$M_{0,max}$	6.2	14.1		
					$M_{max}$	12.7	21.4		
					$n_{eto}$	3177	2750		
071-13	8.3	3700	7.0	3.20	$M_0$		9.5	10.0	
					$M_N$		8.3	8.3	
					$M_{0,max}$		10.8	24.3	
					$M_{max}$		22.0	35.2	
					$n_{eto}$		3517	3000	
071-33	12.3	3600	10.0	4.60	$M_0$		9.9	14.7	14.7
					$M_N$		9.8	12.3	12.3
					$M_{0,max}$		11.2	27.6	38.1
					$M_{max}$		24.8	42.7	52.0
					$n_{eto}$		3368	2840	2350

►  $I...$  [A],  $M...$  [Nm],  $n...$  [r/min],  $P...$  [kW]

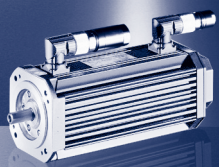

## MD□KS synchronous servo motors

### ECS servo system selection tables

**Mains connection 3 x 400 V and switching frequency  
4 kHz**

#### Motors with blower

					ECS□□	008C□B	016C□B	032C□B	048C□B
					$I_N$	4.0	8.0	12.7	17.0
					$I_{0,max}$	4.6	9.1	18.1	27.2
MDFKS	$M_N$	$n_N$	$I_N$	$P_N$	$I_{max}$	8.0	16.0	32.0	48.0
071-03	7.5	3300	5.6	2.60	$M_0$	5.3	8.8		
					$M_N$	5.4	7.5		
					$M_{0,max}$	6.2	14.6		
					$M_{max}$	13.2	21.6		
					$n_{eto}$	3177	2750		
071-13	11.0	3600	9.2	4.10	$M_0$		9.6	13.3	
					$M_N$		9.6	11.0	
					$M_{0,max}$		10.9	25.0	
					$M_{max}$		22.8	35.2	
					$n_{eto}$		3517	3000	
071-33	16.2	3500	13.1	5.90	$M_0$			15.7	19.3
					$M_N$			15.7	16.2
					$M_{0,max}$			22.4	39.2
					$M_{max}$			43.6	52.0
					$n_{eto}$			2840	2350

►  $I...$  [A],  $M...$  [Nm],  $n...$  [r/min],  $P...$  [kW]



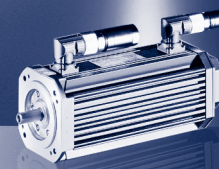

Mains connection 3 x 400 V and switching frequency  
8 kHz

Motors without blower

					EVS	9322-E□	9323-E□	9324-E□	9325-E□	9326-E□	9327-E□
					$I_N$	2.5	3.9	7.0	13.0	23.5	32.0
					$I_{0,max}$	3.8	5.9	10.5	19.5	23.5	32.0
MDSKS	$M_N$	$n_N$	$I_N$	$P_N$	$I_{max}$	3.8	5.9	10.5	19.5	35.3	48.0
056-23	2.8	3800	2.3	1.10	$M_0$	3.1	3.2	3.2			
					$M_N$	2.8	2.8	2.8			
					$M_{0,max}$	4.9	7.4	11.6			
					$M_{max}$	4.9	7.4	11.6			
					$n_{eto}$	3601	3248	2452			
056-33	4.2	4000	3.6	1.80	$M_0$		4.6	4.7	4.7		
					$M_N$		4.2	4.2	4.2		
					$M_{0,max}$		7.6	12.5	17.2		
					$M_{max}$		7.6	12.5	17.2		
					$n_{eto}$		3834	3360	2455		
071-03	5.7	3400	4.2	2.00	$M_0$		5.3	6.7	6.7		
					$M_N$		5.3	5.7	5.7		
					$M_{0,max}$		9.7	15.8	23.6		
					$M_{max}$		9.7	15.8	23.6		
					$n_{eto}$		3291	3047	2500		
071-13	8.3	3700	7.0	3.20	$M_0$			8.3	10.0	10.0	
					$M_N$			8.3	8.3	8.3	
					$M_{0,max}$			15.5	25.7	29.3	
					$M_{max}$			15.5	25.7	35.2	
					$n_{eto}$			3690	3418	3000	
071-33	12.3	3600	10.0	4.60	$M_0$				14.7	14.7	14.7
					$M_N$				12.3	12.3	12.3
					$M_{0,max}$				29.3	34.1	42.7
					$M_{max}$				29.3	45.4	52.0
					$n_{eto}$				3252	2716	2350

►  $I...$  [A],  $M...$  [Nm],  $n...$  [r/min],  $P...$  [kW]

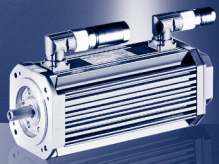

## MDKS synchronous servo motors

### EVS9300 servo inverter selection tables

Mains connection 3 x 400 V and switching frequency  
8 kHz

#### Motors with blower

					EVS	9323-E□	9324-E□	9325-E□	9326-E□	9327-E□
					$I_N$	3.9	7.0	13.0	23.5	32.0
					$I_{0,max}$	5.9	10.5	19.5	23.5	32.0
MDFKS	$M_N$	$n_N$	$I_N$	$P_N$	$I_{max}$	5.9	10.5	19.5	35.3	48.0
071-03	7.5	3300	5.6	2.60	$M_0$	5.2	8.8	8.8		
					$M_N$	5.2	7.5	7.5		
					$M_{0,max}$	7.9	16.3	23.6		
					$M_{max}$	7.9	16.3	23.6		
					$n_{eto}$	3291	3047	2500		
071-13	11.0	3600	9.2	4.10	$M_0$		8.4	13.3	13.3	
					$M_N$		8.4	11.0	11.0	
					$M_{0,max}$		12.6	26.4	29.9	
					$M_{max}$		12.6	26.4	35.2	
					$n_{eto}$		3690	3418	3000	
071-33	16.2	3500	13.1	5.90	$M_0$			16.1	19.3	19.3
					$M_N$			16.1	16.2	16.2
					$M_{0,max}$			30.5	35.2	43.6
					$M_{max}$			30.5	46.2	52.0
					$n_{eto}$			3252	2716	2350

►  $I...$  [A],  $M...$  [Nm],  $n...$  [r/min],  $P...$  [kW]

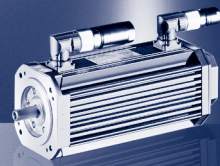

Mains connection 3x 400 V

MDSKS□□056-23

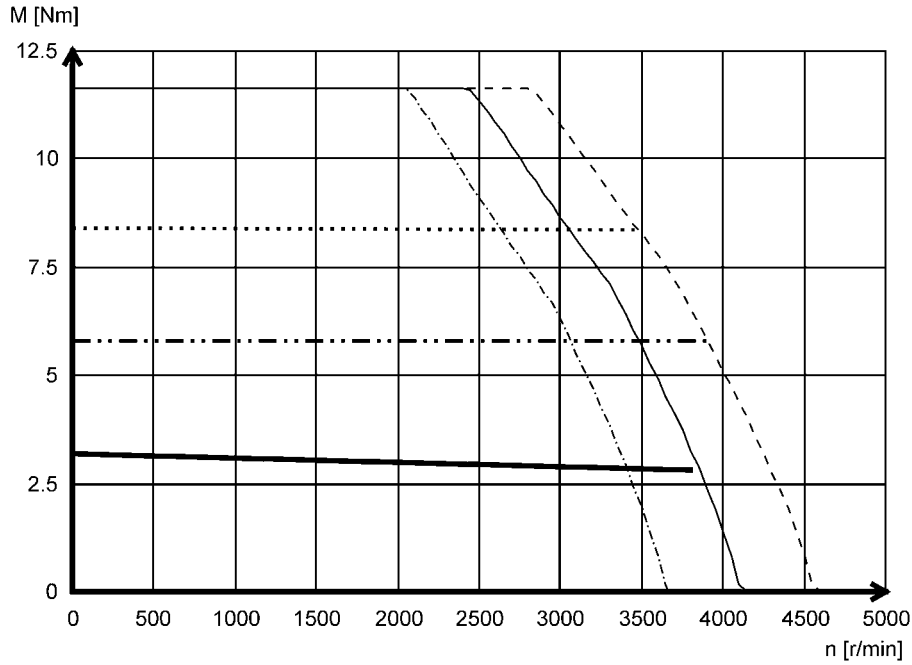

- Mmax 440 V
- Mmax 400 V
- · - · Mmax 360 V
- Mmax @ I<sub>max</sub> = 3x I<sub>0</sub>
- · - · Mmax @ I<sub>max</sub> = 2x I<sub>0</sub>
- S1

4

MDSKS□□056-33

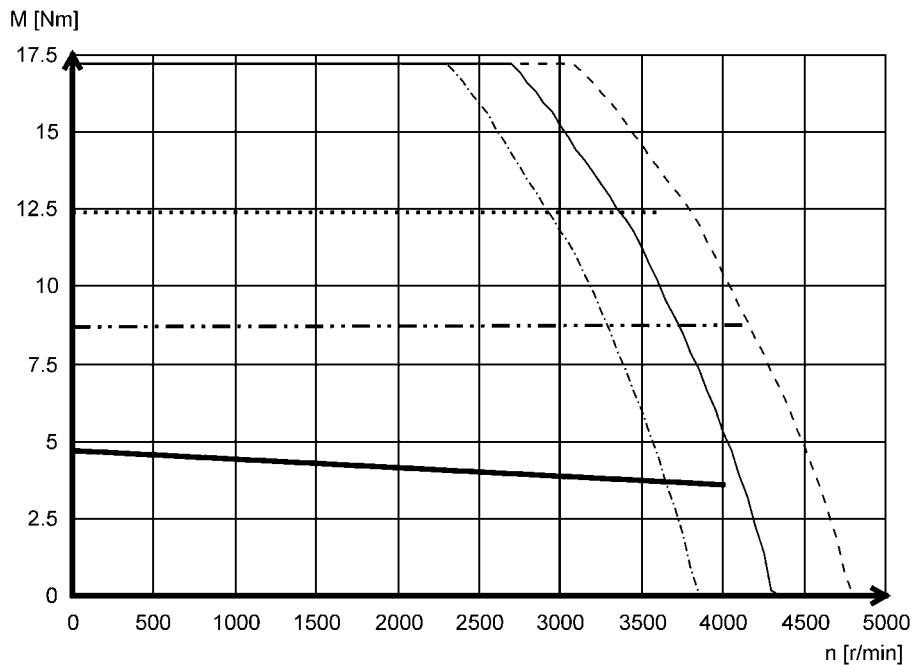

- Mmax 440 V
- Mmax 400 V
- · - · Mmax 360 V
- Mmax @ I<sub>max</sub> = 3x I<sub>0</sub>
- · - · Mmax @ I<sub>max</sub> = 2x I<sub>0</sub>
- S1

► Other torque characteristics with Lenze inverters can be found at [www.lenze.de/dsc](http://www.lenze.de/dsc).

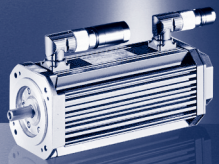

# MDKS synchronous servo motors

## Torque characteristics

Mains connection 3x 400 V

MDSKS□□071-03

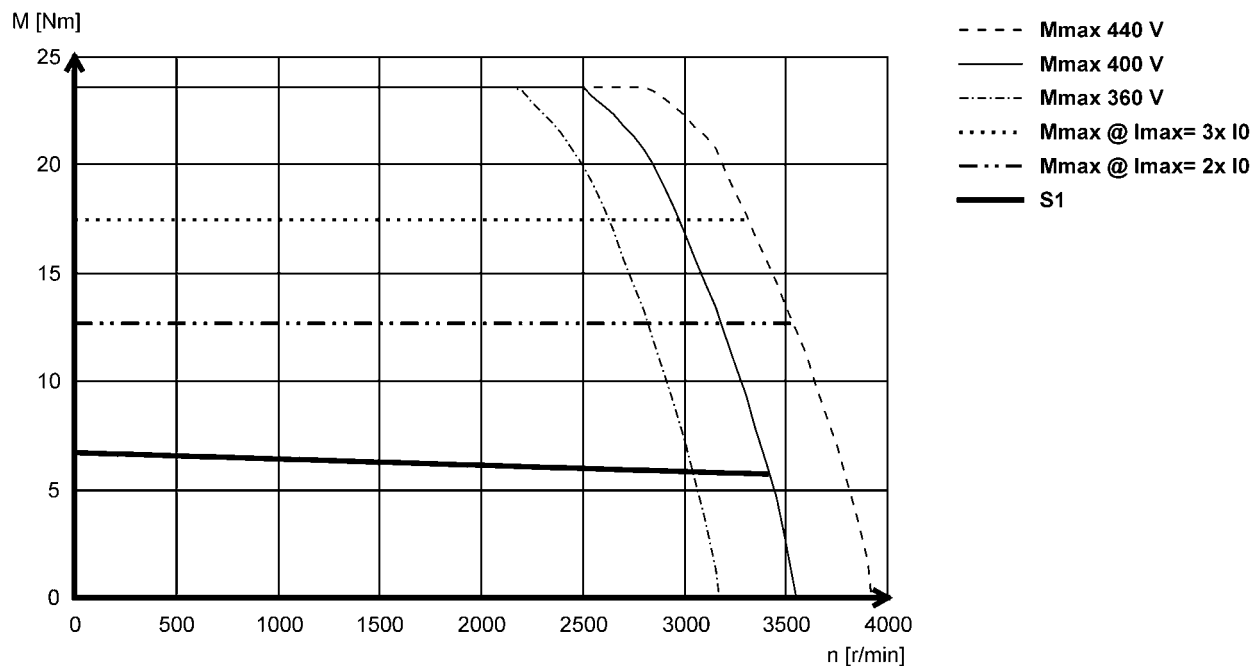

MDFKS□□071-03

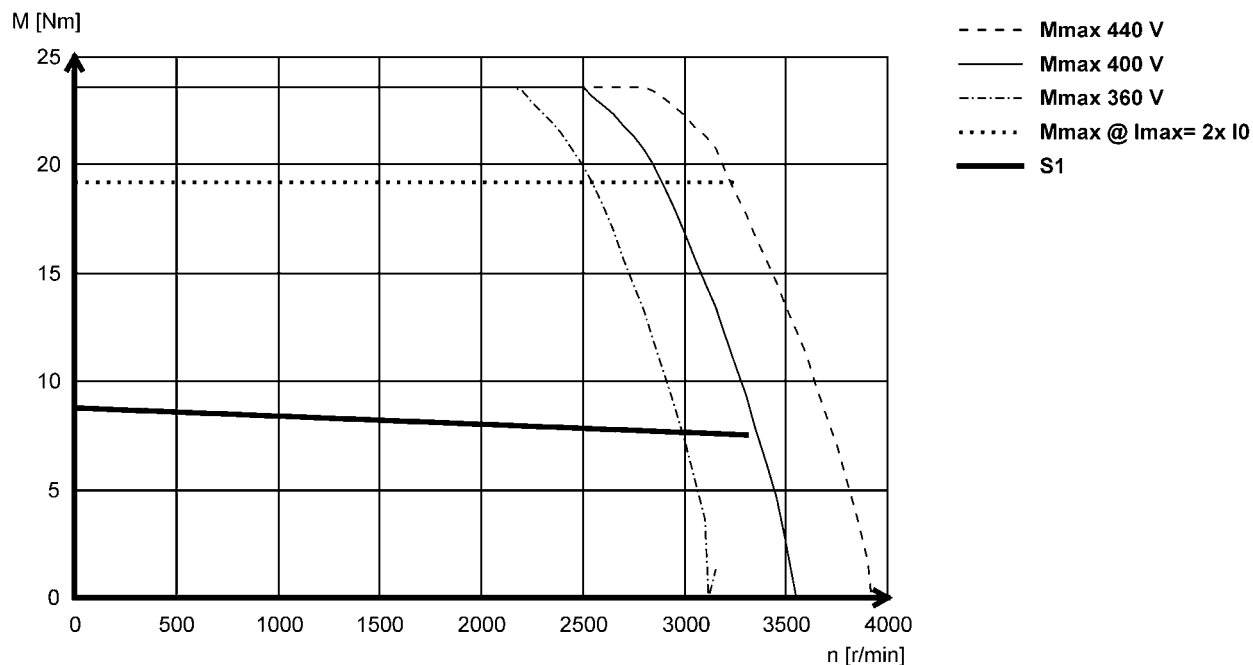

► Other torque characteristics with Lenze inverters can be found at [www.lenze.de/dsc](http://www.lenze.de/dsc).

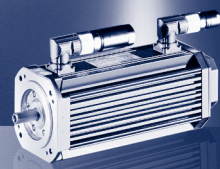

Mains connection 3x 400 V

MDSKS□□071-13

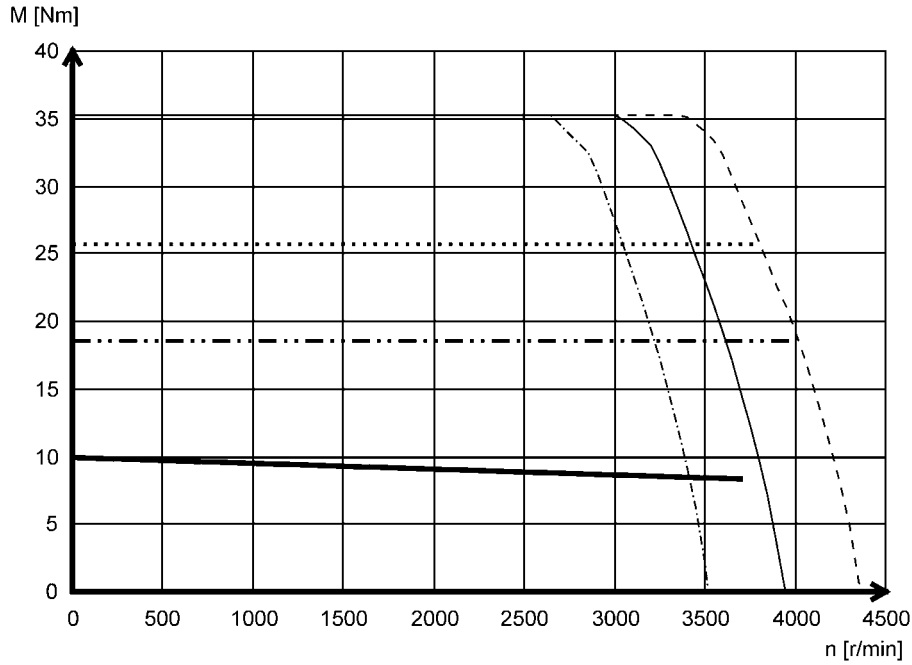

- Mmax 440 V
- Mmax 400 V
- · - · - Mmax 360 V
- Mmax @ Imax= 3x I0
- · · - Mmax @ Imax= 2x I0
- S1

MDFKS□□071-13

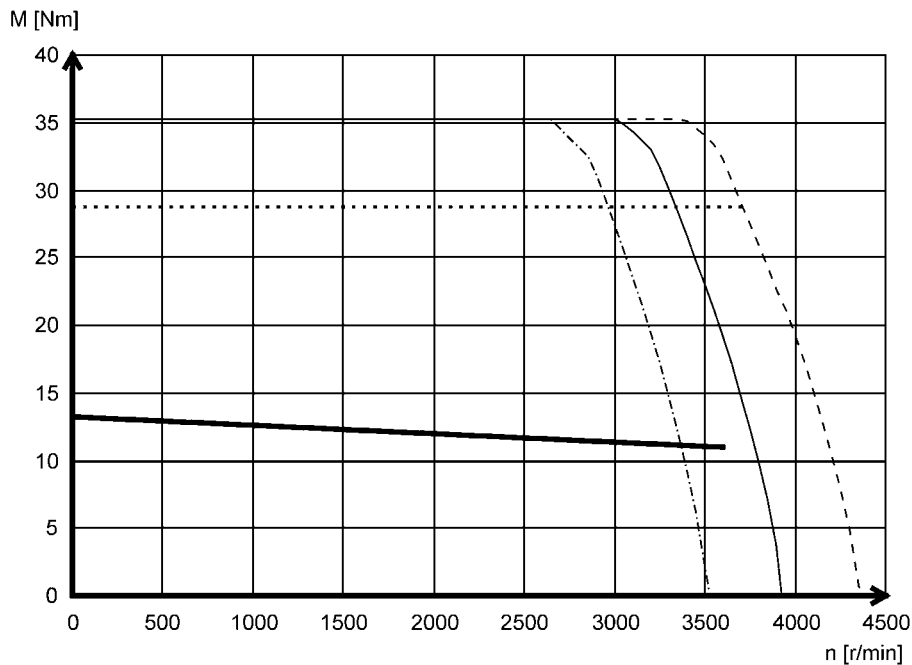

- Mmax 440 V
- Mmax 400 V
- · - · - Mmax 360 V
- Mmax @ Imax= 2x I0
- S1

► Other torque characteristics with Lenze inverters can be found at [www.lenze.de/dsc](http://www.lenze.de/dsc).

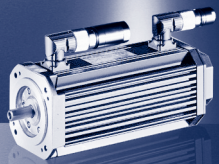

# MDKS synchronous servo motors

## Torque characteristics

Mains connection 3x 400 V

MDSKS□□071-33

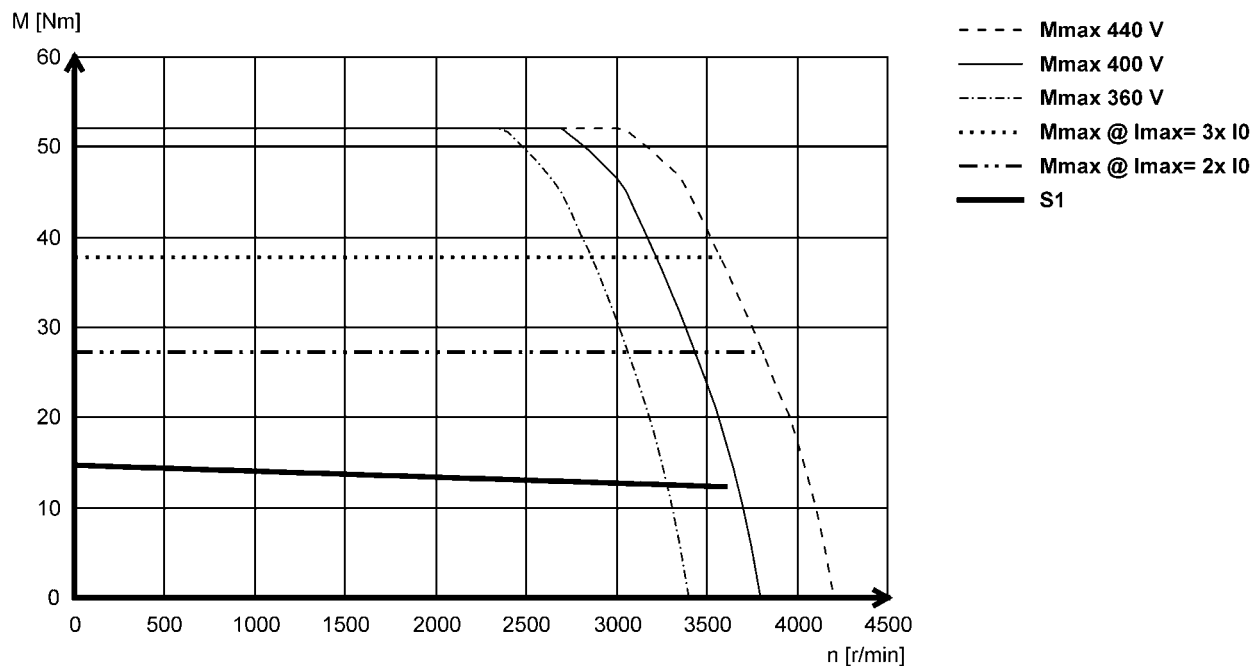

MDFKS□□071-33

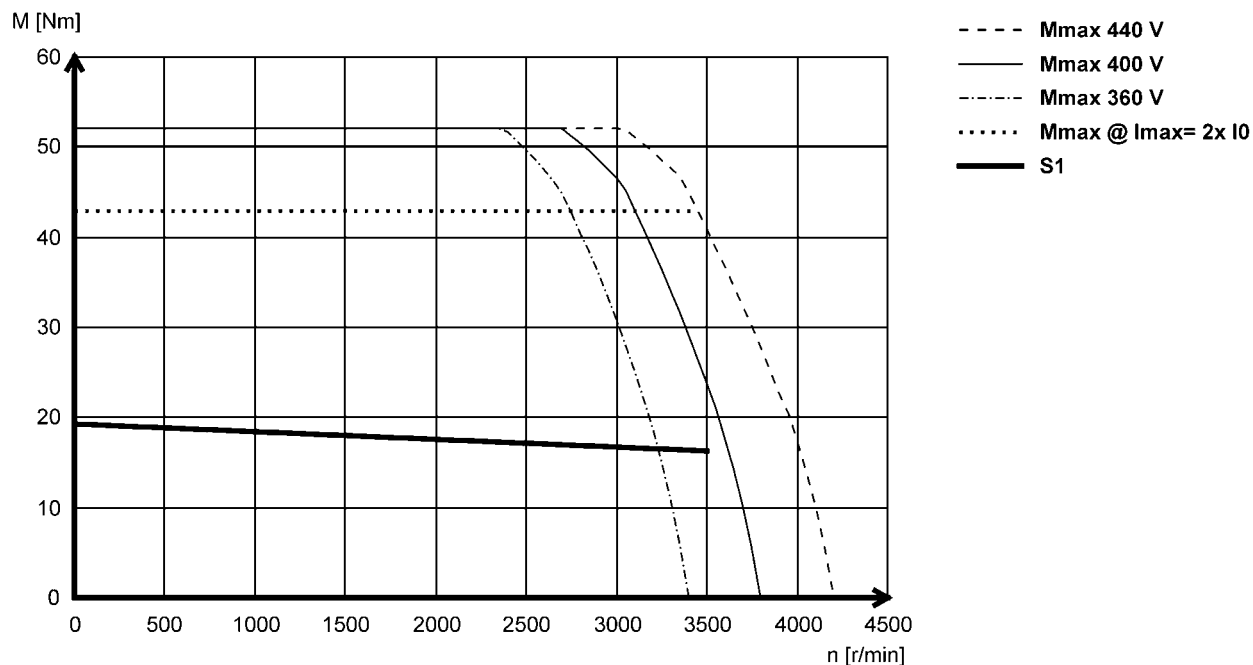

► Other torque characteristics with Lenze inverters can be found at [www.lenze.de/dsc](http://www.lenze.de/dsc).

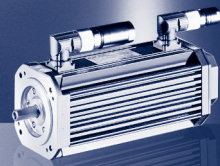

## Motor connection terminal box

If a servo motor is to be connected to an existing cable or plug connectors are not to be used for other reasons, the connection can also be made via a terminal box.

The motor can either be fitted with a terminal box for the power connection and motor holding brake or a second terminal box provided to connect the motor feedback and blower (if applicable).

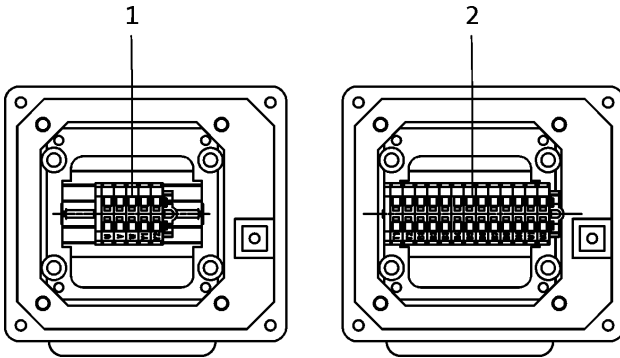

1: Power connection + brake connection + PE connection.

2: Angle/speed sensor connection + thermal sensor connection

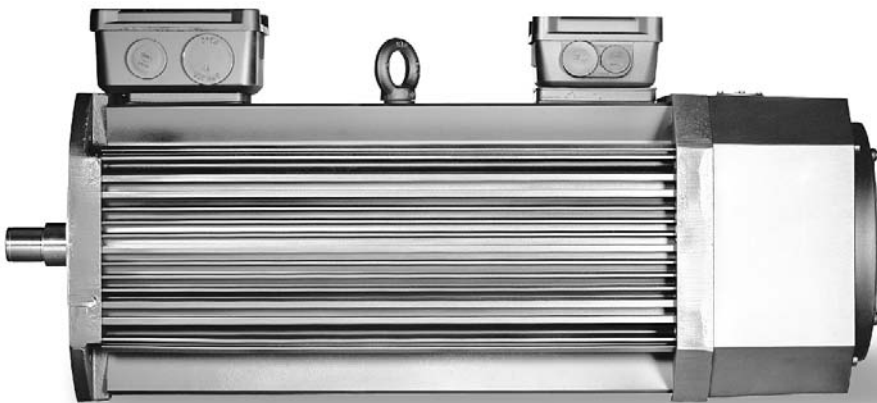

MD□KS synchronous servo motors with blower and terminal box

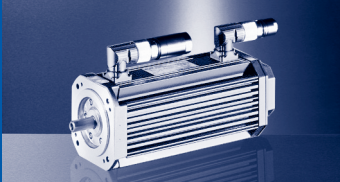

### Holding brakes

The MD□KS synchronous servo motors can be equipped with integral permanent magnet holding brakes. The voltages available for this model are 24 V DC and 205 V DC. The brakes are active once the supply voltage is switched off (closed-circuit principle).

**With traversing axes**, maintaining the permissible mass inertia ratio  $J_L/J_{MB}$  ensures that the permissible maximum switching energy of the brake is not exceeded and at least 2000 emergency stop functions are possible when running at a speed of 3000 r/min.

**With lifting axes**, the load torque resulting from the force due to weight comes into play as an additional factor. In this case, the data specified for  $J_L/J_{MB}$  does not apply.

**Caution:**

**The brakes used are not safety brakes in the sense that a reduction in torque may arise as a result of disruptive factors that cannot be influenced, e.g. oil ingress.**

The ohmic voltage drop along the cable must be taken into consideration in long motor supply cables and must be compensated for by a higher voltage at the line input.

The following applies for Lenze system cables:

$$U[V] = U_B[V] + 0.08 \frac{[V]}{[A] \cdot [m]} \cdot I_{Lg}[m] \cdot I_B[A]$$

If no suitable voltage (incorrect value, incorrect polarity) is applied to the brake, the brake will be applied and can be overheated and destroyed by the motor continuing to rotate. The shortest switching times of the brakes are achieved by DC switching of the voltage. A spark suppressor is required to suppress interference and to increase the service life of the relay contacts here.



*Permanent magnet holding brake*



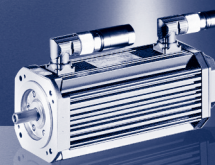

### Holding brake data

- ▶ The ratings apply only for servo motors and for geared servo motors if the servo motor is mounted by way of a mounting flange.

### B5 / B14 design servo motors GPA servo geared motors

	$U_{N,DC}$ <sup>3,4,6)</sup>	$M_N$	$M_N$	$M_{av}$	$I_N$ <sup>2)</sup>	$J$	$t_1$ <sup>1)</sup>	$t_2$ <sup>1)</sup>	$Q_E$ <sup>5)</sup>	$m$	$J_{MB}$	$J_L / J_{MB}$
		20 °C	120 °C	120 °C								
	[V]	[Nm]	[Nm]	[Nm]	[A]	[kgcm <sup>2</sup> ]	[ms]	[ms]	[J]	[kg]	[kgcm <sup>2</sup> ]	
<b>MDSKS□□056-23</b>	24	3.30	2.50	1.20	0.50	0.38	10.0	20.0	350	0.90	1.58	43.9
<b>MDSKS□□056-33</b>					2.18						31.5	
<b>MDSKS□□056-23</b>	205	3.30	2.50	1.20	0.060	0.38	10.0	20.0	350	0.90	1.58	43.9
<b>MDSKS□□056-33</b>					2.18						31.5	
<b>MDSKS□□071-03</b>	24	12.0	11.0	5.50	0.67	1.06	20.0	29.0	400	0.80	7.06	10.5
<b>MDSKS□□071-13</b>					9.06						8.20	
<b>MDSKS□□071-33</b>	205	12.0	11.0	5.50	0.080	1.06	20.0	29.0	400	0.80	7.06	10.5
<b>MDSKS□□071-03</b>					9.06						8.20	
<b>MDSKS□□071-13</b>	24	12.0	11.0	5.50	0.67	1.06	20.0	29.0	400	0.80	7.06	10.5
<b>MDFKS□□071-03</b>					9.06						8.20	
<b>MDFKS□□071-13</b>	205	12.0	11.0	5.50	0.080	1.06	20.0	29.0	400	0.80	7.06	10.5
<b>MDFKS□□071-33</b>					9.06						8.20	
<b>MDFKS□□071-03</b>	24	12.0	11.0	5.50	0.67	1.06	20.0	29.0	400	0.80	7.06	10.5
<b>MDFKS□□071-13</b>					9.06						8.20	
<b>MDFKS□□071-33</b>	205	12.0	11.0	5.50	0.080	1.06	20.0	29.0	400	0.80	7.06	10.5
<b>MDFKS□□071-03</b>					9.06						8.20	
<b>MDFKS□□071-13</b>	24	12.0	11.0	5.50	0.67	1.06	20.0	29.0	400	0.80	7.06	10.5
<b>MDFKS□□071-33</b>					9.06						8.20	
<b>MDFKS□□071-03</b>	205	12.0	11.0	5.50	0.080	1.06	20.0	29.0	400	0.80	7.06	10.5
<b>MDFKS□□071-13</b>					9.06						8.20	
<b>MDFKS□□071-33</b>	24	12.0	11.0	5.50	0.67	1.06	20.0	29.0	400	0.80	7.06	10.5
<b>MDFKS□□071-03</b>					9.06						8.20	
<b>MDFKS□□071-13</b>	205	12.0	11.0	5.50	0.080	1.06	20.0	29.0	400	0.80	7.06	10.5
<b>MDFKS□□071-33</b>					9.06						8.20	

- <sup>1)</sup> Engagement and disengagement times are valid for rated voltage ( $\pm 0\%$ ) and protective circuit for brakes with varistor for DC switching. The times may increase without a protective circuit.
- <sup>2)</sup> The currents are the maximum values when the brake is cold (value used for dimensioning the current supply). The values for a motor at operating temperature are considerably lower.
- <sup>3)</sup> With 24 V DC brake: smoothed DC voltage, ripple  $\leq 1\%$ .  
With 205 V DC brake: connection to 230 V AC through rectifier.
- <sup>4)</sup> UR not possible in the case of a brake with a 205 V supply voltage.
- <sup>5)</sup> Maximum switching energy per emergency stop at  $n = 3000$  r/min for at least 2000 emergency stops.
- <sup>6)</sup> Voltage tolerance:  $-10 \dots +5\%$

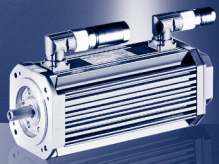

## MD□KS synchronous servo motors Accessories

### Holding brake data

- ▶ These ratings apply only for geared servo motors with integrated servo motor (without mounting flange).

### GST, GFL, GKR, GKS, GSS geared servo motors

	$U_{N,DC}$ <sup>3,4,6)</sup>	$M_N$	$M_N$	$M_{av}$	$I_N$ <sup>2)</sup>	$J$	$t_1$ <sup>1)</sup>	$t_2$ <sup>1)</sup>	$Q_E$ <sup>5)</sup>	$m$	$J_{MB}$	$J_L / J_{MB}$
		20 °C	120 °C	120 °C								
	[V]	[Nm]	[Nm]	[Nm]	[A]	[kgcm <sup>2</sup> ]	[ms]	[ms]	[J]	[kg]	[kgcm <sup>2</sup> ]	
MDSKS□□056-23	24	6.00	5.00	2.50	0.67	1.06	20.0	29.0	400	5.30	2.26	34.9
MDSKS□□056-33										6.30	2.86	27.3
MDSKS□□056-23	205	6.00	5.00	2.50	0.80	1.06	20.0	29.0	400	5.30	2.26	34.9
MDSKS□□056-33										6.30	2.86	27.3
MDSKS□□071-03	24	15.0	12.0	6.00	0.75	3.60	13.0	30.0	700	8.90	9.60	10.6
MDSKS□□071-13										10.9	11.6	8.80
MDSKS□□071-33										13.0	13.6	7.50
MDSKS□□071-03	205	15.0	12.0	6.00	0.090	3.60	13.0	30.0	700	8.90	9.60	10.6
MDSKS□□071-13										10.9	11.6	8.80
MDSKS□□071-33										13.0	13.6	7.50
MDFKS□□071-03	24	15.0	12.0	6.00	0.75	3.60	13.0	30.0	700	10.2	9.60	10.6
MDFKS□□071-13										12.2	11.6	8.80
MDFKS□□071-33										13.6	7.50	
MDFKS□□071-03	205	15.0	12.0	6.00	0.090	3.60	13.0	30.0	700	10.2	9.60	10.6
MDFKS□□071-13										12.2	11.6	8.80
MDFKS□□071-33	13.6	7.50										

<sup>1)</sup> Engagement and disengagement times are valid for rated voltage ( $\pm 0\%$ ) and protective circuit for brakes with varistor for DC switching. The times may increase without a protective circuit.

<sup>2)</sup> The currents are the maximum values when the brake is cold (value used for dimensioning the current supply). The values for a motor at operating temperature are considerably lower.

<sup>3)</sup> With 24 V DC brake: smoothed DC voltage, ripple  $\leq 1\%$ .  
With 205 V DC brake: connection to 230 V AC through rectifier.

<sup>4)</sup> UR not possible in the case of a brake with a 205 V supply voltage.

<sup>5)</sup> Maximum switching energy per emergency stop at  $n = 3000$  r/min for at least 2000 emergency stops.

<sup>6)</sup> Voltage tolerance:  $-10 \dots +5\%$

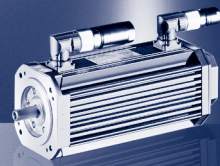

**Blower data 50 Hz**

		Enclosure	Number of phases					
				$U_{min}$	$U_{max}$	$U_{N, AC}$	$P_N$	$I_N$
				[V]	[V]	[V]	[kW]	[A]
MDFKS□□071	F10	IP54	1	210	240	230	0.019	0.12

**Blower data 60 Hz**

		Enclosure	Number of phases					
				$U_{min}$	$U_{max}$	$U_{N, AC}$	$P_N$	$I_N$
				[V]	[V]	[V]	[kW]	[A]
MDFKS□□071	F10	IP54	1	210	240	230	0.019	0.12

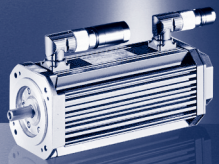

## MD□KS synchronous servo motors Accessories

Tailored to meet the requirements of the various applications and necessary accuracies, the following feedback systems are available.

### Resolver

Stator-fed resolver with two stator windings offset by 90° and one rotor winding with transformer winding.

Built-on accessories	1)			BS RS
<b>Resolution</b>			[°]	0.80
Angle			[°]	-10 ... 10
<b>Accuracy</b>			[°]	-10 ... 10
<b>Absolute positioning</b>				1 revolution
<b>Max. speed</b>	$n_{\max}$		[r/min]	8000
<b>Max. input voltage</b> DC	$U_{\text{in,max}}$		[V]	10.0
<b>Max. input frequency</b>	$f_{\text{in,max}}$		[kHz]	4.00
<b>Ratio</b> Stator / rotor		$\pm 5\%$		0.30
<b>Rotor impedance</b>	$Z_{\text{ro}}$		[ $\Omega$ ]	51 + j90
<b>Stator impedance</b>	$Z_{\text{so}}$		[ $\Omega$ ]	102 + j150
<b>Impedance</b>	$Z_{\text{rs}}$		[ $\Omega$ ]	44 + j76
<b>Min. insulation resistance</b> At DC 500 V	R		[M $\Omega$ ]	10.0
<b>Number of pole pairs</b>				1
<b>Max. angle error</b>			[°]	-10 ... 10
<b>Inverter assignment</b>				E84AVTC E94A ECS EVS93

1) →  20 - Product key > built-on accessories

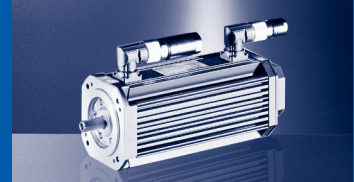

## Incremental encoder and SinCos absolute value encoder

Encoder type			SinCos absolute value	
Built-on accessories	1)		AG BA	
			AS1024-8V-H	AM1024-8V-H
Encoder type			Single-turn	Multi-turn
Pulses			1024	
Output signals			1 Vss	
Interfaces			Hiperface	
Absolute revolutions			1	4096
Resolution Angle <sup>2)</sup>		[°]	0.40	
Accuracy		[°]	-0.8 ... 0.8	
Min. input voltage DC	$U_{in,min}$	[V]	7.00	
Max. input voltage DC	$U_{in,max}$	[V]	12.0	
Max. speed	$n_{max}$	[r/min]	6000	
Max. current consumption	$I_{max}$	[A]	0.080	
Limit frequency	$f_{max}$	[kHz]	200	
Inverter assignment			E84AVTC E94A ECS EVS93	

1) →  20 - Product key > built-on accessories

2) Dependent on inverter.

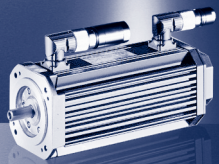

### Thermal sensor

The thermal sensors (1x KTY 83-110) used continuously monitor the motor temperature. The temperature signal is transmitted over the system cable of the feedback system to the servo controller.

This means that the temperature of the motor is determined with great accuracy in the permitted operating range and at the same time the overtemperature response configured in the controller is executed in the event of overtemperature in one of the winding phases.

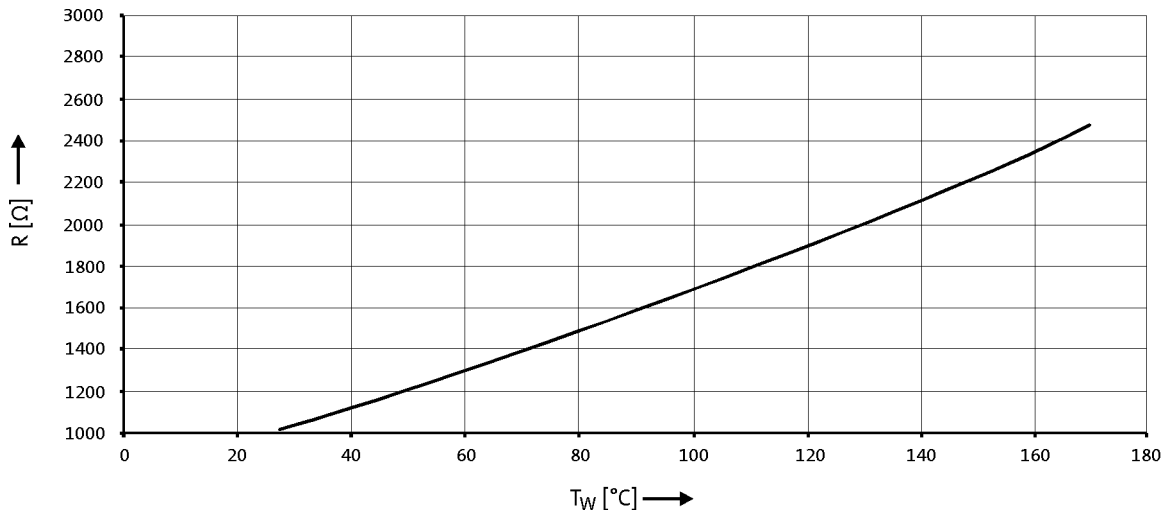

- If the detector is supplied with a measured current of 1 mA, the above relationship between the temperature and the resistance applies.

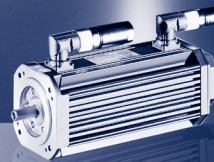

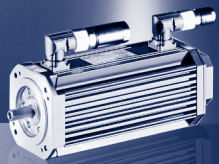

# MD□KS synchronous servo motors

Dimensions [mm]

## Motors without blower

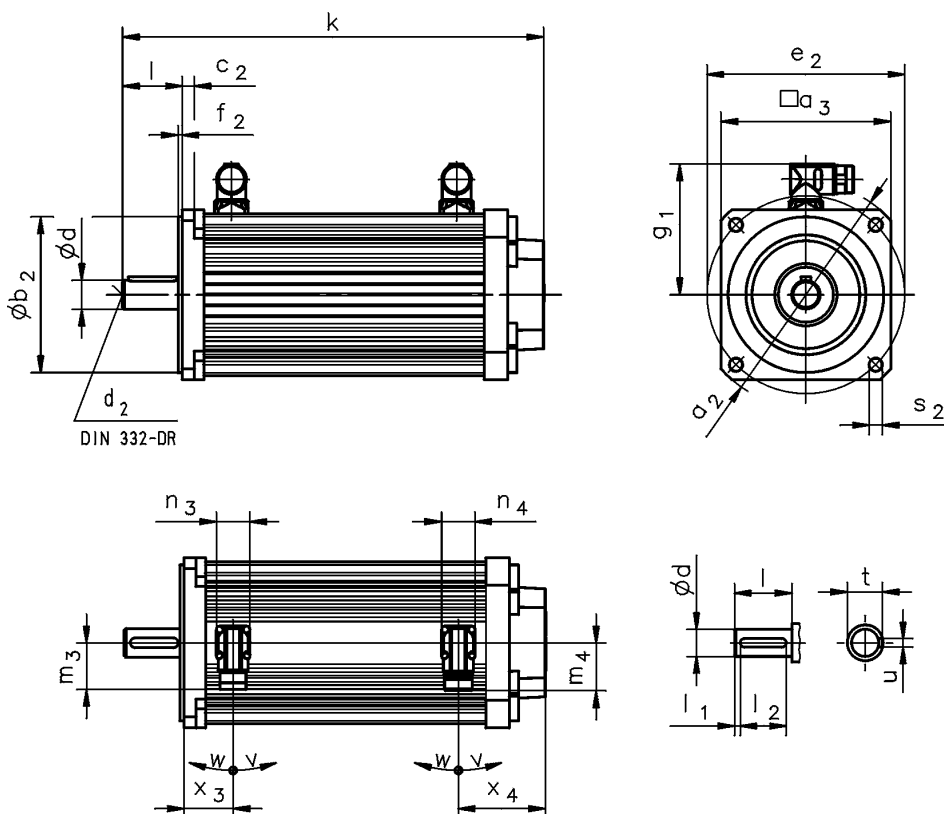

		<b>MDSKS□□056-23</b>		<b>MDSKS□□056-33</b>			
RS	k	[mm]	241		276		
	x <sub>3</sub>	[mm]		36			
	x <sub>4</sub>	[mm]		60			
BS	k	[mm]	267		302		
	x <sub>3</sub>	[mm]		59			
	x <sub>4</sub>	[mm]		60			
AG / IG	k	[mm]	295		330		
	x <sub>3</sub>	[mm]		36			
	x <sub>4</sub>	[mm]		114			
BA / BI	k	[mm]	321		356		
	x <sub>3</sub>	[mm]		59			
	x <sub>4</sub>	[mm]		114			
		<b>MDSKS□□071-03</b>		<b>MDSKS□□071-13</b>		<b>MDSKS□□071-33</b>	
RS	k	[mm]	259	294		329	
	x <sub>3</sub>	[mm]		39			
	x <sub>4</sub>	[mm]		58			
BS	k	[mm]	294	329		364	
	x <sub>3</sub>	[mm]		72			
	x <sub>4</sub>	[mm]		58			
AG / IG	k	[mm]	314	349		384	
	x <sub>3</sub>	[mm]		39			
	x <sub>4</sub>	[mm]		113			
BA / BI	k	[mm]	349	384		419	
	x <sub>3</sub>	[mm]		72			
	x <sub>4</sub>	[mm]		113			



# MD□KS synchronous servo motors

## Dimensions [mm]

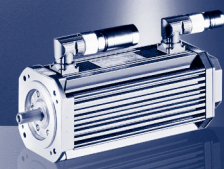

	$g_1$	$n_3$	$n_4$	$m_3$	$m_4$	$v$	$w$
	[mm]	[mm]	[mm]	[mm]	[mm]	[°]	[°]
MDSKS□□056-23	90	28	28	40	40	195	80
MDSKS□□056-33							
MDSKS□□071-03	102						
MDSKS□□071-13							
MDSKS□□071-33							

	$d$	$d_2$	$l$	$l_1$	$l_2$	$u$	$t$
	$k_6$						
	[mm]	[mm]	[mm]	[mm]	[mm]	[mm]	[mm]
MDSKS□□056	14	M5	30	2.5	25	5.0	16
MDSKS□□071	19	M6	40	2.0	36	6.0	22

		$a_2$	$a_3$	$b_2$	$c_2$	$e_2$	$f_2$	$s_2$
				$j_6$				
		[mm]	[mm]	[mm]	[mm]	[mm]	[mm]	[mm]
MDSKS□□056	FF100	120	102	80	8	100	3.0	7
	FT85			70		85	2.5	M6
MDSKS□□071	FF130	160	130	110	9	130	3.5	9.0
	FT130							M8

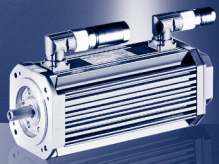

# MDKS synchronous servo motors

Dimensions [mm]

## Motors with blower

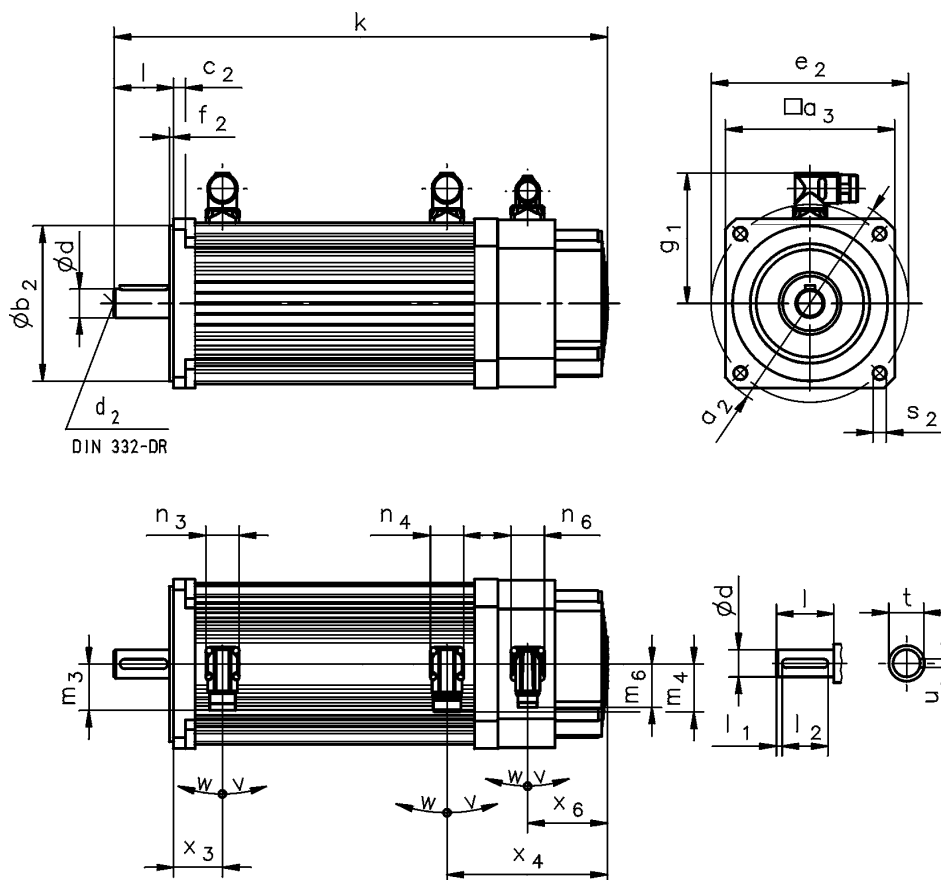

			MDFKS□□071-03	MDFKS□□071-13	MDFKS□□071-33
RS	k	[mm]	327	362	397
	x <sub>3</sub>	[mm]		39	
	x <sub>4</sub>	[mm]		126	
BS	k	[mm]	362	397	432
	x <sub>3</sub>	[mm]		72	
	x <sub>4</sub>	[mm]		126	
AG / IG	k	[mm]	382	417	452
	x <sub>3</sub>	[mm]		39	
	x <sub>4</sub>	[mm]		181	
BA / BI	k	[mm]	417	452	487
	x <sub>3</sub>	[mm]		72	
	x <sub>4</sub>	[mm]		181	
	x <sub>6</sub>	[mm]		73	

# MD□KS synchronous servo motors

Dimensions [mm]

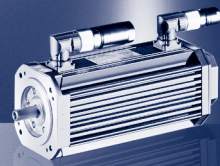

	$g_1$	$n_3$	$n_4$	$n_6$	$m_3$	$m_4$	$m_6$	$v$	$w$
	[mm]	[mm]	[mm]	[mm]	[mm]	[mm]	[mm]	[°]	[°]
<b>MDFKS□□071-03</b>	102	28	28	28	40	40	40	195	80
<b>MDFKS□□071-13</b>									
<b>MDFKS□□071-33</b>									

	$d$	$d_2$	$l$	$l_1$	$l_2$	$u$	$t$
	$k_6$						
	[mm]	[mm]	[mm]	[mm]	[mm]	[mm]	[mm]
<b>MDFKS□□071</b>	19	M6	40	2.0	36	6.0	22

		$a_2$	$a_3$	$b_2$	$c_2$	$e_2$	$f_2$	$s_2$
				$j_6$				
		[mm]	[mm]	[mm]	[mm]	[mm]	[mm]	[mm]
<b>MDFKS□□071</b>	FF130	160	130	110	9	130	3.5	9.0
	FT130							M8

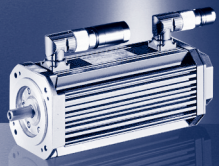

# MD□KS synchronous servo motors

Dimensions [mm]

## Motors with terminal box

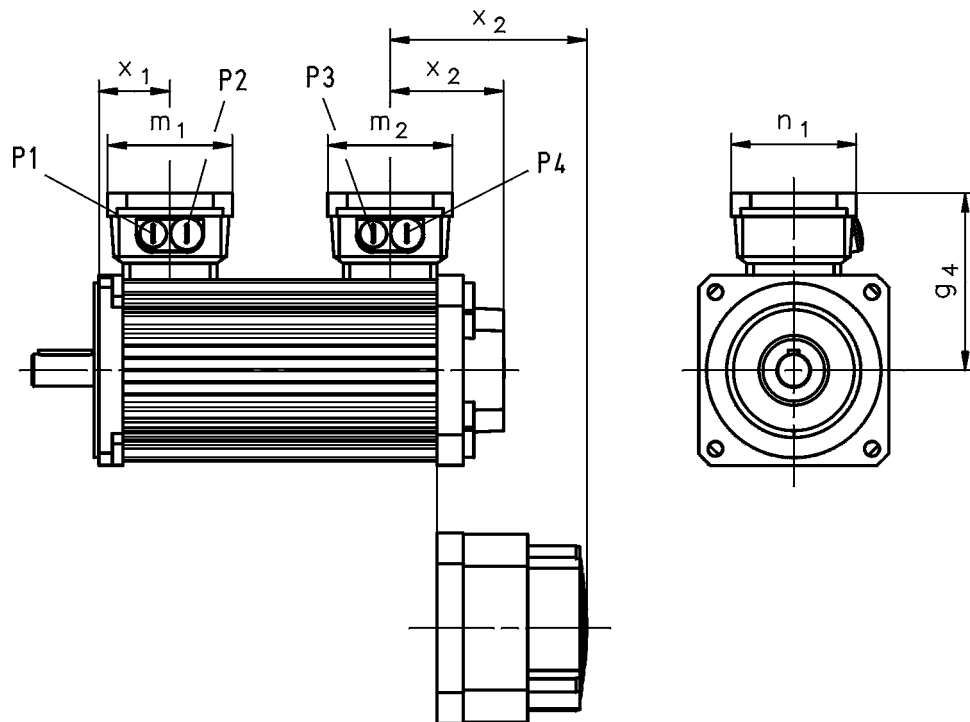

			MDSKS□□056-23	MDSKS□□056-33	MDSKS□□071-03	MDSKS□□071-13	MDSKS□□071-33	
RS	x <sub>2</sub>	[mm]	63	78	62	77		
BS	x <sub>2</sub>	[mm]	78		77			
AG / IG	x <sub>2</sub>	[mm]	117	132	116	131		
BA / IG	x <sub>2</sub>	[mm]	132		131			
			MDFKS□□071-03	MDFKS□□071-13	MDFKS□□071-33			
RS	x <sub>2</sub>	[mm]	130	145				
BS	x <sub>2</sub>	[mm]	145					
AG / IG	x <sub>2</sub>	[mm]	184	199				
BA / IG	x <sub>2</sub>	[mm]	199					

	g <sub>4</sub>	m <sub>1</sub>	m <sub>2</sub>	n <sub>1</sub>	x <sub>1</sub>	P <sub>1</sub>	P <sub>2</sub>	P <sub>3</sub>	P <sub>4</sub>
	[mm]	[mm]	[mm]	[mm]	[mm]	[mm]	[mm]	[mm]	[mm]
MDSKS□□056	113	93	93	93	54	M16x1.5	M20x1.5	M16x1.5	M20x1.5
MDSKS□□071	125				57				
MDFKS□□071									

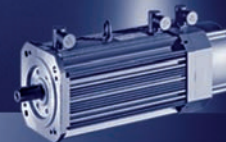

## Mains connection 3x 400 V

### Motors without blower

	$n_N$	$M_0$	$M_{max}$	$M_N$	$P_N$	$I_0$	$I_N$	$U_{N, AC}$	$f_N$	$J^{1)}$	$\eta_{100\%}$
	[r/min]	[Nm]	[Nm]	[Nm]	[kW]	[A]	[A]	[V]	[Hz]	[kgcm <sup>2</sup> ]	[%]
MCA10I40	3950	2.30	10.0	2.00	0.80	2.60	2.40	390	140	2.40	70
MCA13I41	4050	4.60	32.0	4.00	1.70	4.60	4.40	390	140	8.30	75
MCA14L20	2000	8.00	60.0	6.70	1.40	3.90	3.30	390	70	19.2	84
MCA14L41	4100	8.00	60.0	5.40	2.30	7.70	5.80	390	140	19.2	78
MCA17N23	2300	12.8	100	10.8	2.60	6.00	5.50	390	80	36.0	86
MCA17N41	4110	12.8	100	9.50	4.10	12.0	10.2	350	140	36.0	83
MCA19S23	2340	22.5	180	16.3	4.00	9.90	8.20	390	80	72.0	90
MCA19S42	4150	22.5	180	12.0	5.20	19.7	14.0	330	140	72.0	83
MCA21X25	2490	39.0	300	24.6	6.40	15.9	13.5	390	85	180	85
MCA21X42	4160	39.0	300	17.0	7.40	31.8	19.8	320	140	180	84

	$R_1$	$R_{UV\ 20^\circ C}$	$R_{UV\ 150^\circ C}$	$R_2$	$L_{1\sigma}$	$L$	$L_{2\sigma}$	$n_{max}^{2)}$	$m^{1)}$
	[ $\Omega$ ]	[ $\Omega$ ]	[ $\Omega$ ]	[ $\Omega$ ]	[mH]	[mH]	[mH]	[r/min]	[kg]
MCA10I40	4.70	9.40	12.7	8.20	9.80	168	10.0	8000	6.40
MCA13I41	1.70	3.40	4.60	2.20	5.40	98.1	4.90		10.4
MCA14L20	3.00	6.00	8.10	4.90	10.0	269	10.0		15.1
MCA14L41	0.75	1.50	2.00	1.20	2.50	66.6	2.50		22.9
MCA17N23	1.52	3.04	4.10	2.20	6.20	176	6.80		
MCA17N41	0.38	0.76	1.00	0.50	1.50	43.5	1.70		44.7
MCA19S23	0.69	1.38	1.90	1.00	3.20	102	3.90		
MCA19S42	0.18	0.35	0.50	0.20	0.80	25.8	1.00		60.0
MCA21X25	0.36	0.72	1.00	0.60	2.30	78.8	2.80		
MCA21X42	0.090	0.18	0.20	0.10	0.60	19.5	0.70		

<sup>1)</sup> Without brake.

<sup>2)</sup> Mechanically permissible maximum speed.

The data in the  $R_1$ ,  $L_{1\sigma}$ ,  $L_h$ ,  $R_2'$  and  $L_{2\sigma}'$  columns is based on a single-phase equivalent circuit diagram at 20°C.

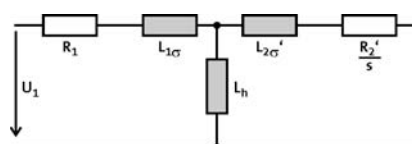

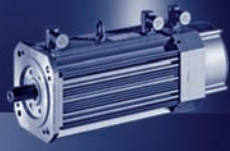

# MCA asynchronou servo motors

## Rated data

### Mains connection 3x 400 V

### Motors with blower, IP54

	$n_N$	$M_0$	$M_{max}$	$M_N$	$P_N$	$I_0$	$I_N$	$U_{N, AC}$	$f_N$	$J^{1)}$	$\eta_{100\%}$
	[r/min]	[Nm]	[Nm]	[Nm]	[kW]	[A]	[A]	[V]	[Hz]	[kgcm <sup>2</sup> ]	[%]
MCA13I34	3410	7.00	32.0	6.30	2.20	6.30	6.00	390	120	8.30	72
MCA14L16	1635	13.5	60.0	12.0	2.10	5.30	4.80	390	60	19.2	80
MCA14L35	3455	13.5	60.0	10.8	3.90	10.5	9.10	390	120	19.2	79
MCA17N17	1680	23.9	100	21.5	3.80	9.10	8.50	390	60	36.0	83
MCA17N35	3480	23.9	100	19.0	6.90	18.1	15.8	390	120	36.0	81
MCA19S17	1700	40.0	180	36.3	6.40	15.4	13.9	390	60	72.0	82
MCA19S35	3510	40.0	180	36.0	13.2	30.8	28.7	390	120	72.0	85
MCA21X17	1710	75.0	300	61.4	11.0	25.8	22.5	390	60	180	85
MCA21X35	3520	75.0	300	55.0	20.3	49.5	42.5	390	120	180	88
MCA22P08...5F□□	760	120	500	110	8.75	23.4	22.1	345	28	487	80
MCA22P14...5F□□	1425	120	500	107	16.0	40.5	37.7	350	50	487	87
MCA22P17...5F□□	1670	120	500	106	18.5	46.7	42.7	360	58	487	88
MCA22P29...5F□□	2935	120	500	100	30.7	80.9	72.1	360	100	487	87
MCA26T05...5F□□	550	220	1100	216	12.4	35.4	34.9	350	19	1335	83
MCA26T10...5F□□	1030	220	1100	210	22.7	62.9	61.5	350	36	1335	88
MCA26T12...5F□□	1200	220	1100	207	26.0	78.4	75.1	350	41	1335	87
MCA26T22...5F□□	2235	220	1100	195	45.6	125	113	340	76	1335	92

	$R_1$	$R_{UV\ 20^\circ C}$	$R_{UV\ 150^\circ C}$	$R_2$	$L_{1\sigma}$	$L$	$L_{2\sigma}$	$n_{max}^{2)}$	$m^{1)}$	
	[Ω]	[Ω]	[Ω]	[Ω]	[mH]	[mH]	[mH]	[r/min]	[kg]	
MCA13I34	1.70	3.40	4.60	2.20	4.90	81.9	4.40	8000	12.0	
MCA14L16	3.00	6.00	8.10	4.90	9.50	252	9.30		16.9	
MCA14L35	0.75	1.50	2.00	1.20	2.40	56.8	2.30		25.5	
MCA17N17	1.52	3.04	4.10	2.20	5.60	143	6.00		48.2	
MCA17N35	0.38	0.76	1.00	0.50	1.40	33.1	1.50		63.5	
MCA19S17	0.69	1.38	1.90	1.00	2.60	56.1	3.10		6500	105
MCA19S35	0.18	0.35	0.50	0.20	0.70	13.0	0.80			
MCA21X17	0.36	0.72	1.00	0.60	2.10	68.7	2.60			
MCA21X35	0.090	0.18	0.20	0.10	0.50	16.6	0.60			
MCA22P08...5F□□	0.54	1.07	1.62	0.75	3.56	85.7	4.80			
MCA22P14...5F□□		0.36	0.54		3.60	88.4	4.85			
MCA22P17...5F□□	0.13	0.27	0.40	0.19	0.90	22.2	1.21			
MCA22P29...5F□□		0.080	0.12		22.1					
MCA26T05...5F□□	0.44	0.59	0.89	0.39	2.58	54.9	4.79			
MCA26T10...5F□□		0.20	0.30		2.62	59.4	4.87			
MCA26T12...5F□□	0.11	0.15	0.23	0.098	0.64	13.2	1.19			
MCA26T22...5F□□		0.050	0.075		0.68	17.6	1.26			

1) Without brake.

2) Mechanically permissible maximum speed.

The data in the  $R_1$ ,  $L_{1\sigma}$ ,  $L_h$ ,  $R_2'$  and  $L_{2\sigma}'$  columns is based on a single-phase equivalent circuit diagram at 20°C.

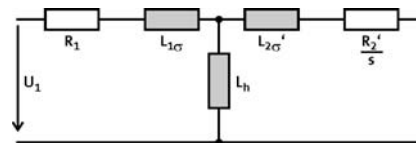

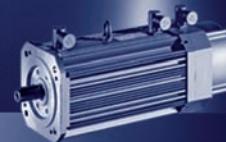

## Mains connection 3x 400 V

### Motors with blower, IP23s

	$n_N$	$M_0$	$M_{max}$	$M_N$	$P_N$	$I_0$	$I_N$	$U_{N, AC}$	$f_N$	$J^{1)}$	$\eta_{100\%}$
	[r/min]	[Nm]	[Nm]	[Nm]	[kW]	[A]	[A]	[V]	[Hz]	[kgcm <sup>2</sup> ]	[%]
MCA20X14...2F□□	1420	68.0	250	61.0	9.07	26.0	23.0	350	50	171	82
MCA20X29...2F□□	2930	68.0	250	53.5	16.4	52.0	42.4	350	100	171	87
MCA22P08...2F□□	760	135	500	120	9.55	26.0	23.5	355	28	487	80
MCA22P14...2F□□	1425	135	500	115	17.2	45.1	40.0	360	50	487	86
MCA22P17...2F□□	1670	135	500	112	19.6	52.1	44.5	360	58	487	88
MCA22P29...2F□□	2935	135	500	110	33.8	90.2	77.8	360	100	487	89
MCA26T05...2F□□	550	290	1100	280	16.1	44.0	42.4	350	20	1335	81
MCA26T10...2F□□	1030	290	1100	260	28.0	78.0	69.6	350	36	1335	87
MCA26T12...2F□□	1200	290	1100	255	32.0	101	83.3	350	41	1335	87
MCA26T22...2F□□	2235	290	1100	230	53.8	160	127	340	76	1335	92

	$R_1$	$R_{UV\ 20^\circ C}$	$R_{UV\ 150^\circ C}$	$R_2$	$L_{1\sigma}$	$L$	$L_{2\sigma}$	$n_{max}^{2)}$	$m^{1)}$
	[ $\Omega$ ]	[ $\Omega$ ]	[ $\Omega$ ]	[ $\Omega$ ]	[mH]	[mH]	[mH]	[r/min]	[kg]
MCA20X14...2F□□	0.37	0.73	1.10	0.57	2.01	54.8	2.14	6500	64.0
MCA20X29...2F□□	0.091	0.18	0.28	0.14	0.50	13.6	0.54		
MCA22P08...2F□□	0.54	1.07	1.62	0.75	4.74	81.6	3.50		105
MCA22P14...2F□□		0.36	0.54		3.55	85.1	4.79		
MCA22P17...2F□□	0.13	0.27	0.40	0.19	0.90	22.2	1.22		194
MCA22P29...2F□□		0.080	0.12				1.21		
MCA26T05...2F□□	0.44	0.59	0.89	0.39	2.60	57.4	4.83		
MCA26T10...2F□□		0.20	0.30		2.63	60.2	4.88		
MCA26T12...2F□□	0.11	0.15	0.23	0.098	0.64	13.3	1.19		
MCA26T22...2F□□		0.050	0.077		0.68	17.7	1.27		

<sup>1)</sup> Without brake.

<sup>2)</sup> Mechanically permissible maximum speed.

The data in the  $R_1$ ,  $L_{1\sigma}$ ,  $L_h$ ,  $R_2'$  and  $L_{2\sigma}'$  columns is based on a single-phase equivalent circuit diagram at 20°C.

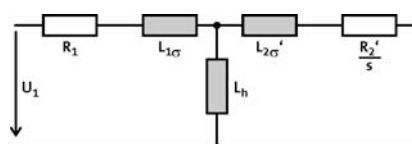

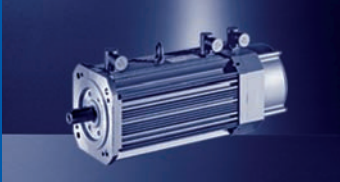

# MCA asynchronous servo motors

## Rated data

### Permissible radial and axial forces

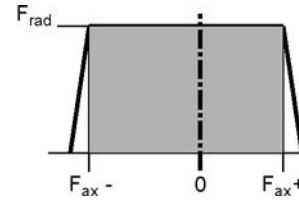
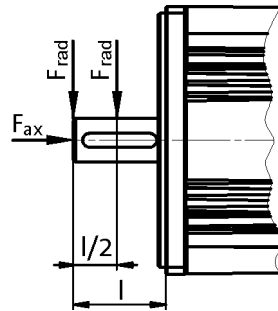

#### Application of force at l/2

	Bearing service life $L_{10}$														
	5000 h			10000 h			20000 h			30000 h			50000 h		
	$F_{rad}$	$F_{ax,-}$	$F_{ax,+}$	$F_{rad}$	$F_{ax,-}$	$F_{ax,+}$	$F_{rad}$	$F_{ax,-}$	$F_{ax,+}$	$F_{rad}$	$F_{ax,-}$	$F_{ax,+}$	$F_{rad}$	$F_{ax,-}$	$F_{ax,+}$
	[N]	[N]	[N]	[N]	[N]	[N]	[N]	[N]	[N]	[N]	[N]	[N]	[N]	[N]	[N]
MCA10	630	-130	320	500	-60	250	400	-30	210	330	-10	190	230	0	200
MCA13	850	-110	570	700	-10	450	470	0	450		0	450			
MCA14	1000	-140	500	780	-60	420	550	-30	380	400	-10	360	250	0	350
MCA17	1380	-180	790	1040	-70	680	660	-40	650	440	-20	630	280		610
MCA19	1880	-50	1530	1080	-30	1510	500	-100	1490	160	0	1470			
MCA20	3400	-1330	690	2500	-1020	380	1950	-780	140	1700	-690	40			
MCA21	3200	-260	1740	2360	-70	1550	1470	-20	1504	1030	0	1480			
MCA22	3600	-2370	1700	2800	-1740	1090	2200	-1280	640	1900	-1080	440	1600	-880	240
MCA26	6950	-2500	1580	5400	-1800	880	4300	-1300	380	3700	-1090	160			

#### Application of force at l

	Bearing service life $L_{10}$														
	5000 h			10000 h			20000 h			30000 h			50000 h		
	$F_{rad}$	$F_{ax,-}$	$F_{ax,+}$	$F_{rad}$	$F_{ax,-}$	$F_{ax,+}$	$F_{rad}$	$F_{ax,-}$	$F_{ax,+}$	$F_{rad}$	$F_{ax,-}$	$F_{ax,+}$	$F_{rad}$	$F_{ax,-}$	$F_{ax,+}$
	[N]	[N]	[N]	[N]	[N]	[N]	[N]	[N]	[N]	[N]	[N]	[N]	[N]	[N]	[N]
MCA10	590	-130	320	470	-60	250	370	-30	210	310	-10	190	220	0	200
MCA13	780	-110	570	640	-10	450	430	0	450	300	0	450			
MCA14	930	-140	500	710	-60	420	490	-30	380	370	-10	360	230	0	350
MCA17	1270	-180	790	960	-70	680	610	-40	650	400	-20	630	260		610
MCA19	1740	-50	1530	1000	-30	1510	420	-100	1490	140	0	1470			
MCA20	3150	-1170	530	2300	-920	280	1800	-710	70	1400	-650	0			
MCA21	2940	-260	1740	2160	-70	1550	1350	-20	1504	950	0	1480			
MCA22	3500	-2240	1600	2600	-1640	1100	2050	-1200	560	1800	-1020	380	1450	-850	200
MCA26	6400	-2080	1150	5000	-1600	680	4000	-1160	230	3400	-1090	50			

- The values for the bearing service life  $L_{10}$  relate to an average speed of 4000 r/min. For MCA20/22/26 the speed is 3000 r/min. Depending on the ambient temperatures, the service life of the bearings is also reduced by the grease lifetime.



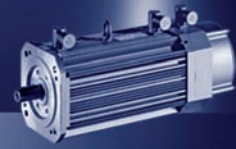

## Permissible radial and axial forces

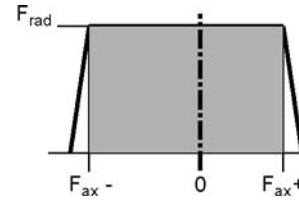
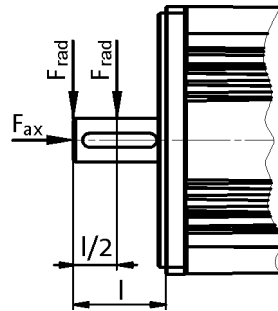

## Reinforced bearings

### Application of force at l/2

	Bearing service life $L_{10}$														
	5000 h			10000 h			20000 h			30000 h			50000 h		
	$F_{rad}$	$F_{ax,-}$	$F_{ax,+}$	$F_{rad}$	$F_{ax,-}$	$F_{ax,+}$	$F_{rad}$	$F_{ax,-}$	$F_{ax,+}$	$F_{rad}$	$F_{ax,-}$	$F_{ax,+}$	$F_{rad}$	$F_{ax,-}$	$F_{ax,+}$
	[N]	[N]	[N]	[N]	[N]	[N]	[N]	[N]	[N]	[N]	[N]	[N]	[N]	[N]	[N]
<b>MCA20</b>	7100	-970	330	5100	-800	160	3900	-640	0						
<b>MCA22</b>	8500	-1850	1200	7000	-1400	760	5600	-1030	390	4350	-930	290	3200	-800	160
<b>MCA26</b>	10500	-2180	1250	8370	-1530	600	6670	-1130	200	5840	-960	30			

### Application of force at l

	Bearing service life $L_{10}$														
	5000 h			10000 h			20000 h			30000 h			50000 h		
	$F_{rad}$	$F_{ax,-}$	$F_{ax,+}$	$F_{rad}$	$F_{ax,-}$	$F_{ax,+}$	$F_{rad}$	$F_{ax,-}$	$F_{ax,+}$	$F_{rad}$	$F_{ax,-}$	$F_{ax,+}$	$F_{rad}$	$F_{ax,-}$	$F_{ax,+}$
	[N]	[N]	[N]	[N]	[N]	[N]	[N]	[N]	[N]	[N]	[N]	[N]	[N]	[N]	[N]
<b>MCA20</b>	6350	-720	80	4100	-680	40	2800		0						
<b>MCA22</b>	7000	-1750	1100	5500	-1300	660	4700	-920	280	3900	-820	180	3000	-700	60
<b>MCA26</b>	9600	-2200	1280	7700	-1280	360	6000	-960	30						

- ▶ The values for the bearing service life  $L_{10}$  refer to an average speed of 3000 r/min. Depending on the ambient temperatures, the service life of the bearings is also reduced by the grease lifetime.

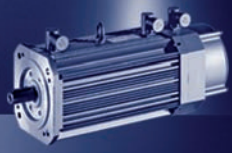

# MCA asynchronous servo motors

## 9400 Servo Drives selection tables

### Mains connection 3 x 400 V and switching frequency 4 kHz

#### Motors without blower

					E94A□□	E0024	E0034	E0044	E0074	E0094	E0134	E0174	E0244	E0324	
					$I_N$	1.9	3.1	5.0	8.8	11.7	16.3	20.6	29.4	38.4	
					$I_{0,max}$	6.0	10.0	16.0	21.0	28.0	39.0	49.5	58.8	76.8	
MCA	$M_N$	$n_N$	$I_N$	$P_N$	$I_{max}$	6.0	10.0	16.0	21.0	28.0	39.0	49.5	58.8	76.8	
10I40	2.0	3950	2.4	0.80	$M_0$	1.1	2.3								
					$M_N$	1.0	2.0								
					$M_{0,max}$	6.9	10.0								
					$M_{max}$	6.9	10.0								
					$\eta_{eto}$	-	-								
13I41	4.0	4050	4.4	1.70	$M_0$			4.6	4.6						
					$M_N$			4.0	4.0						
					$M_{0,max}$			18.9	20.8						
					$M_{max}$			18.9	20.8						
					$\eta_{eto}$			-	-						
14L20	6.7	2000	3.3	1.40	$M_0$		5.1	8.0							
					$M_N$		4.4	6.7							
					$M_{0,max}$		25.0	42.8							
					$M_{max}$		25.0	42.8							
					$\eta_{eto}$		-	-							
14L41	5.4	4100	5.8	2.30	$M_0$			3.5	8.0	8.0					
					$M_N$			3.5	5.4	5.4					
					$M_{0,max}$			21.5	27.0	31.3					
					$M_{max}$			21.5	27.0	31.3					
					$\eta_{eto}$			-	-	-					
17N23	10.8	2300	5.5	2.60	$M_0$			9.5	12.8						
					$M_N$			9.0	10.8						
					$M_{0,max}$			38.0	50.0						
					$M_{max}$			38.0	50.0						
					$\eta_{eto}$			-	-						
17N41	9.5	4110	10.2	4.10	$M_0$				7.1	11.5	12.8	12.8			
					$M_N$				6.7	9.5	9.5	9.5			
					$M_{0,max}$				24.0	33.3	45.8	49.9			
					$M_{max}$				24.0	33.3	45.8	49.9			
					$\eta_{eto}$				-	-	-	-			
19S23	16.3	2340	8.2	4.00	$M_0$				18.4	22.5	22.5				
					$M_N$				15.6	16.3	16.3				
					$M_{0,max}$				55.0	73.7	86.0				
					$M_{max}$				55.0	73.7	86.0				
					$\eta_{eto}$				-	-	-				
19S42	12.0	4150	14.0	5.20	$M_0$						15.0	22.5	22.5		
					$M_N$						12.0	12.0	12.0		
					$M_{0,max}$						48.8	62.0	70.0		
					$M_{max}$						48.8	62.0	70.0		
					$\eta_{eto}$						-	-	-		
21X25	24.6	2490	13.5	6.40	$M_0$					21.4	39.0	39.0	39.0		
					$M_N$						19.6	24.6	24.6	24.6	
					$M_{0,max}$						71.7	96.0	126.0	136.0	
					$M_{max}$						71.7	96.0	126.0	136.0	
					$\eta_{eto}$						-	-	-	-	
21X42	17.0	4160	19.8	7.40	$M_0$								31.3	39.0	
					$M_N$									17.0	17.0
					$M_{0,max}$									71.7	91.0
					$M_{max}$									71.7	91.0
					$\eta_{eto}$									-	-

►  $I...$  [A],  $M...$  [Nm],  $n...$  [r/min],  $P...$  [kW]

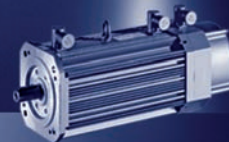

### Mains connection 3 x 400 V and switching frequency 4 kHz

#### Motors with blower, IP54

					E94A□□	E0044	E0074	E0094	E0134	E0174	E0244	E0324	E0474	E0594	E0864
					I <sub>N</sub>	5.0	8.8	11.7	16.3	20.6	29.4	38.4	47.0	59.0	86.0
					I <sub>0,max</sub>	16.0	21.0	28.0	39.0	49.5	58.8	76.8	94.0	118.0	172.0
MCA	M <sub>N</sub>	n <sub>N</sub>	I <sub>N</sub>	P <sub>N</sub>	I <sub>max</sub>	16.0	21.0	28.0	39.0	49.5	58.8	76.8	94.0	118.0	172.0
13I34	6.3	3410	6.0	2.20	M <sub>0</sub>	4.6	7.0	7.0							
					M <sub>N</sub>	4.4	6.3	6.3							
					M <sub>0,max</sub>	20.8	26.0	29.2							
					M <sub>max</sub>	20.8	26.0	29.2							
					η <sub>eto</sub>	-	-	-							
14L16	12.0	1635	4.8	2.10	M <sub>0</sub>	12.0	13.5								
					M <sub>N</sub>	12.0	12.0								
					M <sub>0,max</sub>	45.4	52.6								
					M <sub>max</sub>	45.4	52.6								
					η <sub>eto</sub>	-	-								
14L35	10.8	3455	9.1	3.90	M <sub>0</sub>		10.1	13.5	13.5						
					M <sub>N</sub>		9.7	10.8	10.8						
					M <sub>0,max</sub>		32.4	46.0	60.0						
					M <sub>max</sub>		32.4	46.0	60.0						
					η <sub>eto</sub>		-	-	-						
17N17	21.5	1680	8.5	3.80	M <sub>0</sub>		21.6	23.9	23.9						
					M <sub>N</sub>		21.5	21.5	21.5						
					M <sub>0,max</sub>		59.4	81.4	84.5						
					M <sub>max</sub>		59.4	81.4	84.5						
					η <sub>eto</sub>		-	-	-						
17N35	19.0	3480	15.8	6.90	M <sub>0</sub>				19.4	23.9	23.9				
					M <sub>N</sub>				19.0	19.0	19.0				
					M <sub>0,max</sub>				59.2	75.0	90.0				
					M <sub>max</sub>				59.2	75.0	90.0				
					η <sub>eto</sub>				-	-	-				
19S17	36.3	1700	13.9	6.40	M <sub>0</sub>				40.0	40.0	40.0				
					M <sub>N</sub>				36.3	36.3	36.3				
					M <sub>0,max</sub>				105.0	133.0	148.0				
					M <sub>max</sub>				105.0	133.0	148.0				
					η <sub>eto</sub>				-	-	-				
19S35	36.0	3510	28.7	13.20	M <sub>0</sub>						36.9	40.0	40.0	40.0	
					M <sub>N</sub>						36.0	36.0	36.0	36.0	
					M <sub>0,max</sub>						82.0	112.0	132.0	160.0	
					M <sub>max</sub>						82.0	112.0	132.0	160.0	
					η <sub>eto</sub>						-	-	-	-	
21X17	61.4	1710	22.5	11.00	M <sub>0</sub>					54.4	75.0	75.0	75.0		
					M <sub>N</sub>					50.4	61.4	61.4	61.4		
					M <sub>0,max</sub>					134.0	158.0	215.0	246.0		
					M <sub>max</sub>					134.0	158.0	215.0	246.0		
					η <sub>eto</sub>					-	-	-	-		
21X35	55.0	3520	42.5	20.30	M <sub>0</sub>								63.9	75.0	75.0
					M <sub>N</sub>								55.0	55.0	55.0
					M <sub>0,max</sub>								134.0	167.0	232.0
					M <sub>max</sub>								134.0	167.0	232.0
					η <sub>eto</sub>								-	-	-

► I... [A], M... [Nm], n... [r/min], P... [kW]

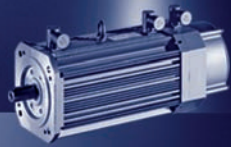

# MCA asynchronous servo motors

## 9400 Servo Drives selection tables

### Mains connection 3 x 400 V and switching frequency 8 kHz

#### Motors with blower, IP54

					E94A□□	E0174	E0244	E0324	E0474	E0594	E0864	E1044	E1454	E1724	E2024	E2454
					$I_N$	16.5	23.5	32.0	41.0	41.0	73.0	78.0	102.0	120.0	131.0	160.0
					$I_{0,max}$	49.5	58.8	76.8	94.0	118.0	172.0	208.0	261.0	310.0	364.0	441.0
MCA	$M_N$	$n_N$	$I_N$	$P_N$	$I_{max}$	49.5	58.8	76.8	94.0	118.0	172.0	208.0	261.0	310.0	364.0	441.0
22P08- ...5F□□	110.0	760	22.1	8.80	$M_0$	64.0	110.0	120.0								
					$M_N$	64.0	110.0	110.0								
					$M_{0,max}$	261.0	313.0	402.0								
					$M_{max}$	261.0	313.0	402.0								
					$\eta_{eto}$	-	-	-								
22P14- ...5F□□	107.0	1425	37.7	16.00	$M_0$			82.0	120.0	120.0						
					$M_N$			82.0	107.0	107.0						
					$M_{0,max}$			242.0	300.0	372.0						
					$M_{max}$			242.0	300.0	372.0						
					$\eta_{eto}$			-	-	-						
22P17- ...5F□□	105.0	1670	42.7	18.50	$M_0$					99.0	120.0					
					$M_N$					99.0	106.0					
					$M_{0,max}$					325.0	463.0					
					$M_{max}$					325.0	463.0					
					$\eta_{eto}$					-	-					
22P29- ...5F□□	100.0	2935	72.1	30.70	$M_0$							110.0	120.0	120.0		
					$M_N$						100.0	100.0	100.0			
					$M_{0,max}$						335.0	416.0	465.0			
					$M_{max}$						335.0	416.0	465.0			
					$\eta_{eto}$						-	-	-			
26T05- ...5F□□	216.0	550	34.9	12.40	$M_0$			191.0	220.0	220.0	220.0					
					$M_N$			191.0	216.0	216.0	216.0					
					$M_{0,max}$			531.0	665.0	826.0	1010.0					
					$M_{max}$			531.0	665.0	826.0	1010.0					
					$\eta_{eto}$			-	-	-	-					
26T10- ...5F□□	210.0	1030	61.5	22.70	$M_0$					77.0	220.0	220.0	220.0			
					$M_N$					77.0	210.0	210.0	210.0			
					$M_{0,max}$					472.0	713.0	855.0	1044.0			
					$M_{max}$					472.0	713.0	855.0	1044.0			
					$\eta_{eto}$					-	-	-	-			
26T12- ...5F□□	207.0	1200	75.1	26.00	$M_0$						204.0	219.0	220.0	220.0		
					$M_N$					204.0	207.0	207.0	207.0			
					$M_{0,max}$					502.0	609.0	739.0	819.0			
					$M_{max}$					502.0	609.0	739.0	819.0			
					$\eta_{eto}$					-	-	-	-			
26T22- ...5F□□	195.0	2235	112.9	45.60	$M_0$								154.0	211.0	220.0	220.0
					$M_N$								154.0	195.0	195.0	195.0
					$M_{0,max}$								523.0	611.0	711.0	843.0
					$M_{max}$								523.0	611.0	711.0	843.0
					$\eta_{eto}$								-	-	-	-

- ▶  $I...$  [A],  $M...$  [Nm],  $n...$  [r/min],  $P...$  [kW]
- ▶ If the motors are operated at a lower switching frequency, please contact your Lenze sales office!
- ▶ When operating at 4 kHz, the motor generates just 95 % of its rated torque with increased noise emissions.

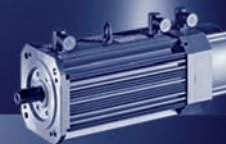

### Mains connection 3 x 400 V and switching frequency 8 kHz

#### Motors with blower, IP23s

MCA	M <sub>N</sub>	n <sub>N</sub>	I <sub>N</sub>	P <sub>N</sub>	E94A□□	E0174	E0244	E0324	E0474	E0594	E0864	E1044	E1454	E1724	E2024	E2454	E2924
					I <sub>N</sub>	16.5	23.5	32.0	41.0	41.0	73.0	78.0	102.0	120.0	131.0	160.0	191.0
					I <sub>0,max</sub>	49.5	58.8	76.8	94.0	118.0	172.0	208.0	261.0	310.0	364.0	441.0	526.0
					I <sub>max</sub>	49.5	58.8	76.8	94.0	118.0	172.0	208.0	261.0	310.0	364.0	441.0	526.0
20X14-...2F□□	61.0	1420	23.0	9.10	M <sub>0</sub>	32.5	66.0										
					M <sub>N</sub>	32.5	61.0										
					M <sub>0,max</sub>	154.2	190.0										
					M <sub>max</sub>	154.2	190.0										
					η <sub>eto</sub>	-	-										
20X29-...2F□□	53.5	2930	42.4	16.40	M <sub>0</sub>			28.0	51.6	51.6							
					M <sub>N</sub>			28.0	51.6	51.6							
					M <sub>0,max</sub>			116.0	148.2	192.8							
					M <sub>max</sub>			116.0	148.2	192.8							
					η <sub>eto</sub>			-	-	-							
22P08-...2F□□	120.0	760	23.5	9.60	M <sub>0</sub>		120.0	135.0									
					M <sub>N</sub>		120.0	120.0									
					M <sub>0,max</sub>		313.0	402.0									
					M <sub>max</sub>		313.0	402.0									
					η <sub>eto</sub>		-	-									
22P14-...2F□□	115.0	1425	40.0	17.20	M <sub>0</sub>				118.0	118.0							
					M <sub>N</sub>				115.0	115.0							
					M <sub>0,max</sub>				300.0	372.0							
					M <sub>max</sub>				300.0	372.0							
					η <sub>eto</sub>				-	-							
22P17-...2F□□	112.0	1670	44.5	19.60	M <sub>0</sub>					99.0	135.0						
					M <sub>N</sub>					99.0	112.0						
					M <sub>0,max</sub>					325.0	463.0						
					M <sub>max</sub>					325.0	463.0						
					η <sub>eto</sub>					-	-						
22P29-...2F□□	110.0	2935	77.8	33.80	M <sub>0</sub>							110.0	135.0	135.0			
					M <sub>N</sub>							110.0	110.0	110.0			
					M <sub>0,max</sub>							335.0	416.0	486.0			
					M <sub>max</sub>							335.0	416.0	486.0			
					η <sub>eto</sub>							-	-	-			
26T05-...2F□□	280.0	550	42.4	16.10	M <sub>0</sub>				268.0	268.0	290.0						
					M <sub>N</sub>				268.0	268.0	280.0						
					M <sub>0,max</sub>				665.0	826.0	1100.0						
					M <sub>max</sub>				665.0	826.0	1100.0						
					η <sub>eto</sub>				-	-	-						
26T10-...2F□□	260.0	1030	69.6	28.00	M <sub>0</sub>						270.0	290.0	290.0				
					M <sub>N</sub>						260.0	260.0	260.0				
					M <sub>0,max</sub>						713.0	855.0	1044.0				
					M <sub>max</sub>						713.0	855.0	1044.0				
					η <sub>eto</sub>						-	-	-				
26T12-...2F□□	255.0	1200	83.3	32.00	M <sub>0</sub>						204.0	219.0	290.0	290.0			
					M <sub>N</sub>						204.0	219.0	255.0	255.0			
					M <sub>0,max</sub>						502.0	609.0	739.0	840.0	896.0		
					M <sub>max</sub>						502.0	609.0	739.0	840.0	896.0		
					η <sub>eto</sub>						-	-	-	-	-		
26T22-...2F□□	230.0	2235	126.7	53.80	M <sub>0</sub>									211.0	242.0	290.0	290.0
					M <sub>N</sub>									211.0	230.0	230.0	230.0
					M <sub>0,max</sub>									611.0	711.0	843.0	1001.0
					M <sub>max</sub>									611.0	711.0	843.0	1001.0
					η <sub>eto</sub>									-	-	-	-

- ▶ I... [A], M... [Nm], n... [r/min], P... [kW]
- ▶ If the motors are operated at a lower switching frequency, please contact your Lenze sales office!
- ▶ When operating at 4 kHz, the motor generates just 95 % of its rated torque with increased noise emissions.

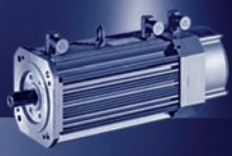

# MCA asynchronou servo motors

## Selection tables for Inverter Drives 8400 TopLine

**Mains connection 3 x 400 V and switching frequency  
8 kHz**

**Motors without blower**

					E84AVTC	□5514	□7514	□1124	□1524	□2224	□3024	□4024	□5524	□7524	□1134	□1534	□1834				
					I <sub>N</sub>	1.8	2.4	3.2	3.9	5.9	7.3	9.5	13.0	16.5	23.5	32.0	39.0				
					I <sub>0,max</sub>	2.7	3.6	4.8	5.9	8.4	11.0	14.3	19.5	26.4	32.9	43.2	60.0				
MCA	M <sub>N</sub>	n <sub>N</sub>	I <sub>N</sub>	P <sub>N</sub>	I <sub>max</sub>	3.6	4.8	6.4	7.8	11.8	14.6	19.0	26.0	33.0	47.0	64.0	78.0				
10I40	2.0	3950	2.4	0.80	M <sub>0</sub>	-	2.3	2.3	2.3	2.3											
					M <sub>N</sub>	-	1.9	1.9	1.9	1.9											
					M <sub>0,max</sub>	4.2	5.8	8.0	9.8	11.4											
					M <sub>max</sub>	4.2	5.8	8.0	9.8	11.4											
					η <sub>eto</sub>	-	-	-	-	-											
13I41	4.0	4050	4.4	1.70	M <sub>0</sub>					4.6	4.6	4.6									
					M <sub>N</sub>					4.0	4.0	4.0									
					M <sub>0,max</sub>			7.6	9.6	14.3	18.9	22.9									
					M <sub>max</sub>			7.6	9.6	14.3	18.9	22.9									
					η <sub>eto</sub>			-	-	-	-	-									
14L20	6.7	2000	3.3	1.40	M <sub>0</sub>		-	-	8.0	8.0	8.0										
					M <sub>N</sub>		-	-	6.7	6.7	6.7										
					M <sub>0,max</sub>		11.6	16.2	20.1	29.4	34.7										
					M <sub>max</sub>		11.6	16.2	20.1	29.4	34.7										
					η <sub>eto</sub>		-	-	-	-	-										
14L41	5.4	4100	5.8	2.30	M <sub>0</sub>					-	8.0	8.0	8.0								
					M <sub>N</sub>					-	5.4	5.4	5.4								
					M <sub>0,max</sub>					14.1	19.0	25.1	31.0								
					M <sub>max</sub>					14.1	19.0	25.1	31.0								
					η <sub>eto</sub>					-	-	-	-								
17N23	10.8	2300	5.5	2.60	M <sub>0</sub>					12.8	12.8	12.8	12.8								
					M <sub>N</sub>					10.8	10.8	10.8	10.8								
					M <sub>0,max</sub>			17.1	25.3	33.3	43.8	51.1									
					M <sub>max</sub>			17.1	25.3	33.3	43.8	51.1									
					η <sub>eto</sub>			-	-	-	-	-									
17N41	9.5	4110	10.2	4.10	M <sub>0</sub>						-	-	12.8	12.8	12.8						
					M <sub>N</sub>						-	-	9.5	9.5	9.5						
					M <sub>0,max</sub>						16.5	22.3	31.1	39.9	49.5						
					M <sub>max</sub>						16.5	22.3	31.1	39.9	49.5						
					η <sub>eto</sub>						-	-	-	-	-						
19S23	16.3	2340	8.2	4.00	M <sub>0</sub>							-	22.5	22.5	22.5						
					M <sub>N</sub>							-	16.3	16.3	16.3						
					M <sub>0,max</sub>						32.8	43.6	60.9	77.5							
					M <sub>max</sub>						32.8	43.7	61.0	77.5							
					η <sub>eto</sub>						-	-	-	-	-						
19S42	12.0	4150	14.0	5.20	M <sub>0</sub>								-	22.5	22.5	22.5					
					M <sub>N</sub>								-	12.0	12.0	12.0					
					M <sub>0,max</sub>								28.5	37.0	53.7	64.7					
					M <sub>max</sub>								28.5	37.0	53.8	64.7					
					η <sub>eto</sub>								-	-	-	-					
21X25	24.6	2490	13.5	6.40	M <sub>0</sub>								-	39.0	39.0	39.0					
					M <sub>N</sub>								-	24.5	24.5	24.5					
					M <sub>0,max</sub>								33.6	46.7	59.3	85.9	97.3				
					M <sub>max</sub>								33.6	46.7	59.3	85.9	97.6				
					η <sub>eto</sub>								-	-	-	-					
21X42	17.0	4160	19.8	7.40	M <sub>0</sub>									-	39.0	39.0	39.0				
					M <sub>N</sub>									-	17.0	17.0	17.0				
					M <sub>0,max</sub>										35.3	52.2	72.1	88.5			
					M <sub>max</sub>										35.3	52.2	72.1	88.5			
					η <sub>eto</sub>										-	-	-	-			

► I... [A], M... [Nm], n... [r/min], P... [kW]

# MCA asynchronou servo motors

Selection tables for Inverter Drives 8400 TopLine

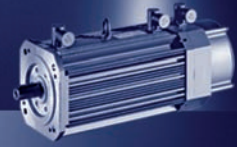

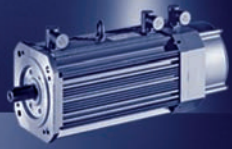

# MCA asynchronou servo motors

Selection tables for Inverter Drives 8400 TopLine

Mains connection 3 x 400 V and switching frequency  
8 kHz

Motors with blower, IP54

					E84AVTC	□1524	□2224	□3024	□4024	□5524	□7524	
					$I_N$	3.9	5.9	7.3	9.5	13.0	16.5	
					$I_{0,max}$	5.9	8.4	11.0	14.3	19.5	26.4	
MCA	$M_N$	$n_N$	$I_N$	$P_N$	$I_{max}$	7.8	11.8	14.6	19.0	26.0	33.0	
13I34	6.3	3410	6.0	2.20	$M_0$		-	7.0	7.0	7.0		
					$M_N$		-	6.2	6.2	6.2		
					$M_{0,max}$		16.0	21.4	28.2	35.9		
					$M_{max}$		16.0	21.4	28.2	35.9		
					$\eta_{eto}$		-	-	-	-		
14L16	12.0	1635	4.8	2.10	$M_0$	-	13.5	13.5	13.5			
					$M_N$	-	12.3	12.3	12.3			
					$M_{0,max}$	23.4	34.7	45.5	50.8			
					$M_{max}$	23.4	34.7	45.5	50.8			
					$\eta_{eto}$	-	-	-	-			
14L35	10.8	3455	9.1	3.90	$M_0$			-	13.5	13.5	13.5	
					$M_N$			-	10.8	10.8	10.8	
					$M_{0,max}$			21.1	28.4	39.8	51.1	
					$M_{max}$			21.1	28.4	39.8	51.1	
					$\eta_{eto}$			-	-	-	-	
17N17	21.5	1680	8.5	3.80	$M_0$			-	23.9	23.9	23.9	
					$M_N$			-	21.6	21.6	21.6	
					$M_{0,max}$			42.1	55.9	77.5	93.3	
					$M_{max}$			42.2	56.0	77.5	93.3	
					$\eta_{eto}$			-	-	-	-	
17N35	19.0	3480	15.8	6.90	$M_0$				-	-	23.9	
					$M_N$				-	-	18.9	
					$M_{0,max}$					38.0	49.5	
					$M_{max}$					38.0	49.5	
					$\eta_{eto}$					-	-	
19S17	36.3	1700	13.9	6.40	$M_0$				-	-	40.0	
					$M_N$				-	-	36.0	
					$M_{0,max}$					71.6	94.7	
					$M_{max}$					71.6	94.7	
					$\eta_{eto}$					-	-	
19S35	36.0	3510	28.7	13.20	$M_0$							
					$M_N$							
					$M_{0,max}$							
					$M_{max}$							
					$\eta_{eto}$							
21X17	61.4	1710	22.5	11.00	$M_0$						-	
					$M_N$							-
					$M_{0,max}$						99.0	
					$M_{max}$						99.0	
					$\eta_{eto}$						-	
21X35	55.0	3520	42.5	20.30	$M_0$							
					$M_N$							
					$M_{0,max}$							
					$M_{max}$							
					$\eta_{eto}$							

► I... [A], M... [Nm], n... [r/min], P... [kW]



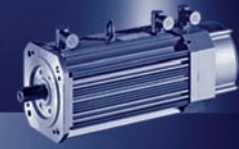

## Mains connection 3 x 400 V and switching frequency 8 kHz

### Motors with blower, IP54

□1134	□1534	□1834	□2234	□3034	□3734	□4534	E84AVTC					
23.5	32.0	39.0	47.0	61.0	76.0	89.0	$I_N$	$P_N$	$I_N$	$n_N$	$M_N$	MCA
32.9	43.2	60.0	70.5	91.5	114.0	133.5	$I_{0,max}$					
47.0	64.0	78.0	94.0	122.0	152.0	178.0	$I_{max}$					
							$M_0$					
							$M_N$					
							$M_{0,max}$	2.20	6.0	3410	6.3	13I34
							$M_{max}$					
							$n_{eto}$					
							$M_0$					
							$M_N$					
							$M_{0,max}$	2.10	4.8	1635	12.0	14L16
							$M_{max}$					
							$n_{eto}$					
13.5							$M_0$					
10.8							$M_N$					
56.5							$M_{0,max}$	3.90	9.1	3455	10.8	14L35
56.6							$M_{max}$					
-							$n_{eto}$					
							$M_0$					
							$M_N$					
							$M_{0,max}$	3.80	8.5	1680	21.5	17N17
							$M_{max}$					
							$n_{eto}$					
23.9	23.9						$M_0$					
18.9	18.9						$M_N$					
72.5	97.8						$M_{0,max}$	6.90	15.8	3480	19.0	17N35
72.5	97.8						$M_{max}$					
-	-						$n_{eto}$					
40.0	40.0						$M_0$					
36.0	36.0						$M_N$					
138.9	165.2						$M_{0,max}$	6.40	13.9	1700	36.3	19S17
139.0	165.3						$M_{max}$					
-	-						$n_{eto}$					
-	40.0	40.0	40.0	40.0			$M_0$					
-	35.9	35.9	35.9	35.9			$M_N$					
55.1	78.8	97.8	112.8	146.2			$M_{0,max}$	13.20	28.7	3510	36.0	19S35
55.1	78.8	97.8	112.9	146.2			$M_{max}$					
-	-	-	-	-			$n_{eto}$					
75.0	75.0	75.0	75.0				$M_0$					
61.4	61.4	61.4	61.4				$M_N$					
143.7	198.5	242.2	277.2				$M_{0,max}$	11.00	22.5	1710	61.4	21X17
144.0	198.7	242.3	277.2				$M_{max}$					
-	-	-	-				$n_{eto}$					
-	-	-	75.0	75.0	75.0	75.0	$M_0$					
-	-	-	55.1	55.1	55.1	55.1	$M_N$					
-	97.5	120.6	138.5	177.5	216.7	267.8	$M_{0,max}$	20.30	42.5	3520	55.0	21X35
-	97.5	120.6	138.6	178.0	217.5	269.8	$M_{max}$					
-	-	-	-	-	-	-	$n_{eto}$					

► I... [A], M... [Nm], n... [r/min], P... [kW]

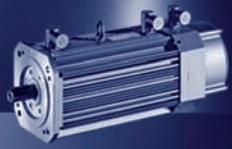

## MCA asynchronous servo motors

Selection tables for Inverter Drives 8400 TopLine

**Mains connection 3 x 400 V and switching frequency  
8 kHz**

**Motors with blower, IP54**

					E84AVTC	□7524	□1134	□1534	□1834	□2234	□3034	□3734	□4534
					$I_N$	16.5	23.5	32.0	39.0	47.0	61.0	76.0	89.0
					$I_{0,max}$	26.4	32.9	43.2	60.0	70.5	91.5	114.0	133.5
MCA	$M_N$	$n_N$	$I_N$	$P_N$	$I_{max}$	33.0	47.0	64.0	78.0	94.0	122.0	152.0	178.0
22P08- ...5F□□	110.0	760	22.1	8.80	$M_0$	-	-	120.0	120.0	135.0			
					$M_N$	-	120.6	144.5	110.6	144.5			
					$M_{0,max}$	157.8	222.8	323.3	377.0	372.9			
					$M_{max}$	157.8	223.0	323.3	377.0	400.9			
					$n_{eto}$	-	-	-	-	-			
22P14- ...5F□□	107.0	1425	37.7	16.00	$M_0$			-	-	120.0	118.0	156.0	118.0
					$M_N$			-	107.2	115.3	107.2	134.7	107.2
					$M_{0,max}$			188.4	232.5	270.8	343.7	425.8	458.8
					$M_{max}$			186.7	235.1	269.0	344.4	423.7	514.4
					$n_{eto}$			-	-	-	-	-	-
22P17- ...5F□□	105.0	1670	42.7	18.50	$M_0$			-	-	135.0	120.0	156.0	135.0
					$M_N$			-	-	112.1	112.1	129.8	105.8
					$M_{0,max}$			162.7	204.6	236.9	309.7	376.9	461.2
					$M_{max}$			162.7	198.6	237.1	300.0	367.5	449.9
					$n_{eto}$			-	-	-	-	-	-
22P29- ...5F□□	100.0	2935	72.1	30.70	$M_0$						-	120.0	120.0
					$M_N$						-	99.9	99.9
					$M_{0,max}$						180.0	218.9	263.2
					$M_{max}$						180.7	225.0	264.1
					$n_{eto}$						-	-	-

- ▶  $I...$  [A],  $M...$  [Nm],  $n...$  [r/min],  $P...$  [kW]
- ▶ If the motors are operated at a lower switching frequency, please contact your Lenze sales office!

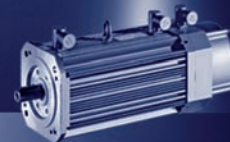

## Mains connection 3 x 400 V and switching frequency 8 kHz

### Motors with blower, IP23s

					E84AVTC	□7524	□1134	□1534	□1834	□2234	□3034	□3734	□4534		
					$I_N$	16.5	23.5	32.0	39.0	47.0	61.0	76.0	89.0		
					$I_{0,max}$	26.4	32.9	43.2	60.0	70.5	91.5	114.0	133.5		
MCA	$M_N$	$n_N$	$I_N$	$P_N$	$I_{max}$	33.0	47.0	64.0	78.0	94.0	122.0	152.0	178.0		
20X14- ...2F□□	61.0	1420	23.0	9.10	$M_0$	-	67.0	67.0	67.0	67.0					
					$M_N$	-	61.2	61.2	61.2	61.2					
					$M_{0,max}$	94.8	139.9	192.6	235.5	272.2					
					$M_{max}$	94.9	139.9	192.8	235.7	272.5					
					$\eta_{eto}$	-	-	-	-	-					
20X29- ...2F□□	53.5	2930	42.4	16.40	$M_0$			-	-	57.0	57.0	57.0	57.0		
					$M_N$			-	-	53.4	53.4	53.4	53.4		
					$M_{0,max}$			96.8	121.2	140.3	182.5	222.1	272.5		
					$M_{max}$			96.8	121.2	140.4	182.6	223.0	274.5		
					$\eta_{eto}$			-	-	-	-	-	-		
22P08- ...2F□□	120.0	760	23.5	9.60	$M_0$	-	135.0	120.0	120.0	135.0					
					$M_N$	-	120.6	144.5	110.6	120.6					
					$M_{0,max}$	157.8	234.2	323.3	377.0	394.3					
					$M_{max}$	157.8	234.8	323.3	377.0	372.9					
					$\eta_{eto}$	-	-	-	-	-					
22P14- ...2F□□	115.0	1425	40.0	17.20	$M_0$			-	-	120.0	156.0	156.0	118.0		
					$M_N$			-	107.2	115.3	107.2	134.7	107.2		
					$M_{0,max}$			188.4	232.5	268.8	345.7	422.7	493.6		
					$M_{max}$			188.7	230.6	271.0	350.3	423.7	460.9		
					$\eta_{eto}$			-	-	-	-	-	-		
22P17- ...2F□□	112.0	1670	44.5	19.60	$M_0$			-	-	135.0	120.0	156.0	135.0		
					$M_N$			-	-	112.1	112.1	129.8	105.8		
					$M_{0,max}$			162.7	204.6	236.9	309.7	376.9	461.2		
					$M_{max}$			162.7	198.6	238.2	308.3	367.5	449.9		
					$\eta_{eto}$			-	-	-	-	-	-		
22P29- ...2F□□	110.0	2935	77.8	33.80	$M_0$						-	120.0	120.0		
					$M_N$								-	99.9	99.9
					$M_{0,max}$						180.0	218.9	263.2		
					$M_{max}$						180.7	225.0	264.1		
					$\eta_{eto}$						-	-	-		

- ▶  $I...$  [A],  $M...$  [Nm],  $n...$  [r/min],  $P...$  [kW]
- ▶ If the motors are operated at a lower switching frequency, please contact your Lenze sales office!

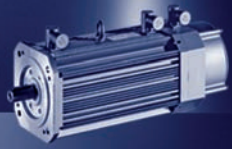

# MCA asynchronous servo motors

## ECS servo system selection tables

### Mains connection 3 x 400 V and switching frequency 4 kHz

#### Motors without blower

					ECS□□	008C□B	016C□B	032C□B	048C□B	064C□B
					$I_N$	4.0	8.0	12.7	17.0	20.0
					$I_{0,max}$	4.6	9.1	18.1	27.2	36.3
MCA	$M_N$	$n_N$	$I_N$	$P_N$	$I_{max}$	8.0	16.0	32.0	48.0	64.0
10I40	2.0	3950	2.4	0.80	$M_0$	2.3				
					$M_N$	2.0				
					$M_{0,max}$	5.6				
					$M_{max}$	8.1				
					$\eta_{eto}$	-				
13I41	4.0	4050	4.4	1.70	$M_0$	3.0	4.6			
					$M_N$	3.0	4.0			
					$M_{0,max}$	4.3	11.0			
					$M_{max}$	9.4	18.2			
					$\eta_{eto}$	-	-			
14L20	6.7	2000	3.3	1.40	$M_0$	8.0	8.0			
					$M_N$	6.7	6.7			
					$M_{0,max}$	10.7	25.3			
					$M_{max}$	21.6	42.8			
					$\eta_{eto}$	-	-			
14L41	5.4	4100	5.8	2.30	$M_0$		8.0	8.0		
					$M_N$		5.4	5.4		
					$M_{0,max}$		11.0	24.0		
					$M_{max}$		20.7	29.1		
					$\eta_{eto}$		-	-		
17N23	10.8	2300	5.5	2.60	$M_0$		12.8	12.8		
					$M_N$		10.8	10.8		
					$M_{0,max}$		20.5	43.5		
					$M_{max}$		40.2	63.7		
					$\eta_{eto}$		-	-		
17N41	9.5	4110	10.2	4.10	$M_0$		6.1	12.8	12.8	
					$M_N$		6.1	9.5	9.5	
					$M_{0,max}$		7.8	21.5	33.5	
					$M_{max}$		17.4	29.6	57.7	
					$\eta_{eto}$		-	-	-	
19S23	16.3	2340	8.2	4.00	$M_0$		15.1	22.5		
					$M_N$		15.1	16.3		
					$M_{0,max}$		18.7	43.5		
					$M_{max}$		38.5	67.9		
					$\eta_{eto}$		-	-		
19S42	12.0	4150	14.0	5.20	$M_0$			9.8	16.7	
					$M_N$			9.8	12.0	
					$M_{0,max}$			18.4	31.9	
					$M_{max}$			29.9	58.2	
					$\eta_{eto}$			-	-	
21X25	24.6	2490	13.5	6.40	$M_0$			21.0	39.0	
					$M_N$			21.0	24.6	
					$M_{0,max}$			41.0	64.5	
					$M_{max}$			64.4	120.5	
					$\eta_{eto}$			-	-	
21X42	17.0	4160	19.8	7.40	$M_0$				13.0	17.0
					$M_N$				13.0	17.0
					$M_{0,max}$				30.0	45.0
					$M_{max}$				59.4	83.0
					$\eta_{eto}$				-	-

►  $I...$  [A],  $M...$  [Nm],  $n...$  [r/min],  $P...$  [kW]

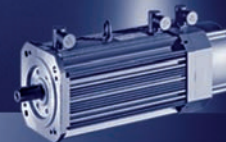

### Mains connection 3 x 400 V and switching frequency 4 kHz

#### Motors with blower, IP54

					ECS□□	008C□B	016C□B	032C□B	048C□B	064C□B
					$I_N$	4.0	8.0	12.7	17.0	20.0
					$I_{0,max}$	4.6	9.1	18.1	27.2	36.3
MCA	$M_N$	$n_N$	$I_N$	$P_N$	$I_{max}$	8.0	16.0	32.0	48.0	64.0
13I34	6.3	3410	6.0	2.20	$M_0$		7.0			
					$M_N$		6.3			
					$M_{0,max}$		10.7			
					$M_{max}$		20.8			
					$n_{eto}$		-			
14L16	12.0	1635	4.8	2.10	$M_0$	8.9	13.5			
					$M_N$	8.9	12.0			
					$M_{0,max}$	11.5	25.4			
					$M_{max}$	21.6	46.7			
					$n_{eto}$	-	-			
14L35	10.8	3455	9.1	3.90	$M_0$		8.3	13.5	13.5	
					$M_N$		8.3	10.8	10.8	
					$M_{0,max}$		11.0	27.0	41.0	
					$M_{max}$		22.2	42.0	67.8	
					$n_{eto}$		-	-	-	
17N17	21.5	1680	8.5	3.80	$M_0$		19.5	23.9		
					$M_N$		19.5	21.5		
					$M_{0,max}$		23.0	53.0		
					$M_{max}$		44.8	80.0		
					$n_{eto}$		-	-		
17N35	19.0	3480	15.8	6.90	$M_0$			12.7	23.0	
					$M_N$			12.7	19.0	
					$M_{0,max}$			23.0	37.5	
					$M_{max}$			37.7	64.4	
					$n_{eto}$			-	-	
19S17	36.3	1700	13.9	6.40	$M_0$			28.3	40.0	40.0
					$M_N$			28.3	36.3	36.3
					$M_{0,max}$			46.5	72.0	98.0
					$M_{max}$			75.4	130.8	158.9
					$n_{eto}$			-	-	-
21X17	61.4	1710	22.5	11.00	$M_0$					52.5
					$M_N$					52.5
					$M_{0,max}$					107.0
					$M_{max}$					190.0
					$n_{eto}$					-

►  $I...$  [A],  $M...$  [Nm],  $n...$  [r/min],  $P...$  [kW]

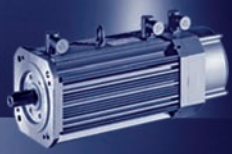

# MCA asynchronous servo motors

## EVS9300 servo inverter selection tables

**Mains connection 3 x 400 V and switching frequency  
8 kHz**

### Motors without blower

					EVS	9322-E□	9323-E□	9324-E□	9325-E□	9326-E□	9327-E□	9328-E□	9329-E□
					$I_N$	2.5	3.9	7.0	13.0	23.5	32.0	47.0	59.0
					$I_{0,max}$	3.8	5.9	10.5	19.5	23.5	32.0	47.0	52.0
MCA	$M_N$	$n_N$	$I_N$	$P_N$	$I_{max}$	3.8	5.9	10.5	19.5	35.3	48.0	70.5	88.5
10I40	2.0	3950	2.4	0.80	$M_0$	2.2	2.3						
					$M_N$	2.0	2.0						
					$M_{0,max}$	4.4	7.3						
					$M_{max}$	4.4	7.3						
					$\eta_{eto}$	-	-						
13I41	4.0	4050	4.4	1.70	$M_0$			4.6	4.6				
					$M_N$			4.0	4.0				
					$M_{0,max}$			12.6	19.5				
					$M_{max}$			12.6	19.5				
					$\eta_{eto}$			-	-				
14L20	6.7	2000	3.3	1.40	$M_0$		8.0	8.0					
					$M_N$		6.7	6.7					
					$M_{0,max}$		15.1	29.3					
					$M_{max}$		15.1	29.3					
					$\eta_{eto}$		-	-					
14L41	5.4	4100	5.8	2.30	$M_0$			7.0	8.0				
					$M_N$			5.4	5.4				
					$M_{0,max}$			13.2	26.0				
					$M_{max}$			13.2	26.0				
					$\eta_{eto}$			-	-				
17N23	10.8	2300	5.5	2.60	$M_0$			12.8	12.8				
					$M_N$			10.8	10.8				
					$M_{0,max}$			24.4	46.2				
					$M_{max}$			24.4	46.2				
					$\eta_{eto}$			-	-				
17N41	9.5	4110	10.2	4.10	$M_0$				12.8	12.8			
					$M_N$				9.5	9.5	9.5		
					$M_{0,max}$				23.4	37.0	54.0		
					$M_{max}$				23.4	43.7	59.4		
					$\eta_{eto}$				-	-	-		
19S23	16.3	2340	8.2	4.00	$M_0$				22.5	22.5			
					$M_N$				16.3	16.3			
					$M_{0,max}$				47.2	78.0			
					$M_{max}$				47.2	88.2			
					$\eta_{eto}$				-	-	-		
19S42	12.0	4150	14.0	5.20	$M_0$				10.0	22.5	22.5		
					$M_N$				10.0	12.0	12.0		
					$M_{0,max}$				20.7	33.5	51.0		
					$M_{max}$				20.7	43.3	60.7		
					$\eta_{eto}$				-	-	-		
21X25	24.6	2490	13.5	6.40	$M_0$				23.7	39.0	39.0		
					$M_N$				23.7	24.6	24.6		
					$M_{0,max}$				46.2	66.0	84.0		
					$M_{max}$				46.2	78.0	92.4		
					$\eta_{eto}$				-	-	-		
21X42	17.0	4160	19.8	7.40	$M_0$					24.0	39.0	39.0	39.0
					$M_N$					17.0	17.0	17.0	17.0
					$M_{0,max}$					24.0	47.0	84.0	94.0
					$M_{max}$					43.9	63.3	96.8	123.0
					$\eta_{eto}$					-	-	-	-

►  $I...$  [A],  $M...$  [Nm],  $n...$  [r/min],  $P...$  [kW]

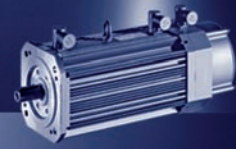

Mains connection 3 x 400 V and switching frequency  
8 kHz

Motors with blower, IP54

					EVS	9324-E□	9325-E□	9326-E□	9327-E□	9328-E□	9329-E□	9330-E□	9331-E□
					$I_N$	7.0	13.0	23.5	32.0	47.0	59.0	89.0	110.0
					$I_{0,max}$	10.5	19.5	23.5	32.0	47.0	52.0	80.0	110.0
MCA	$M_N$	$n_N$	$I_N$	$P_N$	$I_{max}$	10.5	19.5	35.3	48.0	70.5	88.5	133.5	165.0
13I34	6.3	3410	6.0	2.20	$M_0$	7.0	7.0						
					$M_N$	6.3	6.3						
					$M_{0,max}$	13.0	25.0						
					$M_{max}$	13.0	25.0						
					$\eta_{eto}$	-	-						
14L16	12.0	1635	4.8	2.10	$M_0$	13.5							
					$M_N$	12.0							
					$M_{0,max}$	29.6							
					$M_{max}$	29.6							
					$\eta_{eto}$	-							
14L35	10.8	3455	9.1	3.90	$M_0$		13.5	13.5					
					$M_N$		10.8	10.8					
					$M_{0,max}$		29.3	47.0					
					$M_{max}$		29.3	53.8					
					$\eta_{eto}$		-	-					
17N17	21.5	1680	8.5	3.80	$M_0$		23.9						
					$M_N$		21.5						
					$M_{0,max}$		57.2						
					$M_{max}$		57.2						
					$\eta_{eto}$		-						
17N35	19.0	3480	15.8	6.90	$M_0$			23.9	23.9	23.9			
					$M_N$			19.0	19.0	19.0			
					$M_{0,max}$			27.5	57.0	89.0			
					$M_{max}$			50.7	69.2	100.2			
					$\eta_{eto}$			-	-	-			
19S17	36.3	1700	13.9	6.40	$M_0$		34.0	40.0	40.0				
					$M_N$		34.0	36.3	36.3				
					$M_{0,max}$		50.1	76.0	112.0				
					$M_{max}$		50.1	95.9	130.8				
					$\eta_{eto}$		-	-	-				
19S35	36.0	3510	28.7	13.20	$M_0$			21.0	39.0	40.0	40.0	40.0	
					$M_N$			21.0	36.0	36.0	36.0	36.0	
					$M_{0,max}$			21.0	39.0	73.0	80.0	161.5	
					$M_{max}$			45.7	67.6	104.3	132.9	180.0	
					$\eta_{eto}$			-	-	-	-	-	
21X17	61.4	1710	22.5	11.00	$M_0$			65.5	75.0	75.0	75.0		
					$M_N$			61.4	61.4	61.4	61.4		
					$M_{0,max}$			65.5	102.0	178.0	200.0		
					$M_{max}$			104.1	143.3	210.7	257.3		
					$\eta_{eto}$			-	-	-	-		
21X35	55.0	3520	42.5	20.30	$M_0$					68.0	75.0	75.0	75.0
					$M_N$					55.0	55.0	55.0	55.0
					$M_{0,max}$					68.0	88.0	156.0	219.0
					$M_{max}$					107.7	135.9	205.0	250.1
					$\eta_{eto}$					-	-	-	-

►  $I...$  [A],  $M...$  [Nm],  $n...$  [r/min],  $P...$  [kW]

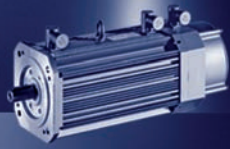

## MCA asynchronous servo motors

### EVS9300 servo inverter selection tables

#### Mains connection 3 x 400 V and switching frequency 8 kHz

#### Motors with blower, IP54

					EVS	9326-E□	9327-E□	9328-E□	9329-E□	9330-E□	9331-E□	9332-E□
					$I_N$	23.5	32.0	47.0	59.0	89.0	110.0	145.0
					$I_{0,max}$	23.5	32.0	47.0	52.0	80.0	110.0	126.0
MCA	$M_N$	$n_N$	$I_N$	$P_N$	$I_{max}$	35.3	48.0	70.5	88.5	133.5	165.0	217.5
22P08- ...5F□□	110.0	760	22.1	8.80	$M_0$	115.0	120.0	120.0	120.0			
					$M_N$	108.0	110.0	110.0	110.0			
					$M_{0,max}$	115.0	166.0	242.0	267.0			
					$M_{max}$	185.0	247.0	338.8	345.8			
					$\eta_{eto}$	-	-	-	-			
22P14- ...5F□□	107.0	1425	37.7	16.00	$M_0$			120.0	120.0	120.0		
					$M_N$			107.0	107.0	107.0		
					$M_{0,max}$			146.0	160.0	264.0		
					$M_{max}$			230.1	292.9	341.8		
					$\eta_{eto}$			-	-	-		
22P17- ...5F□□	105.0	1670	42.7	18.50	$M_0$			120.0	120.0	120.0	120.0	
					$M_N$			106.0	106.0	106.0	106.0	
					$M_{0,max}$			124.0	140.0	240.0	335.0	
					$M_{max}$			180.5	227.7	342.1	378.3	
					$\eta_{eto}$			-	-	-	-	
22P29- ...5F□□	100.0	2935	72.1	30.70	$M_0$					118.0	120.0	120.0
					$M_N$					100.0	100.0	100.0
					$M_{0,max}$					122.0	171.0	200.0
					$M_{max}$					215.6	273.1	355.1
					$\eta_{eto}$					-	-	-
26T05- ...5F□□	216.0	550	34.9	12.40	$M_0$		191.0	220.0	220.0	220.0		
					$M_N$		191.0	216.0	216.0	216.0		
					$M_{0,max}$		191.0	303.0	333.0	615.0		
					$M_{max}$		313.0	482.0	612.0	751.0		
					$\eta_{eto}$		-	-	-	-		
26T10- ...5F□□	210.0	1030	61.5	22.70	$M_0$				159.0	220.0	220.0	
					$M_N$				197.0	210.0	210.0	
					$M_{0,max}$				159.0	300.0	440.0	
					$M_{max}$				343.0	552.0	671.0	
					$\eta_{eto}$				-	-	-	
26T12- ...5F□□	207.0	1200	75.1	26.00	$M_0$					207.0	220.0	220.0
					$M_N$				255.0	207.0	207.0	
					$M_{0,max}$				258.0	327.0	397.0	
					$M_{max}$				424.0	512.0	663.0	
					$\eta_{eto}$				-	-	-	
26T22- ...5F□□	195.0	2235	112.9	45.60	$M_0$						177.0	220.0
					$M_N$					177.0	195.0	
					$M_{0,max}$					203.0	220.0	
					$M_{max}$					315.0	432.0	
					$\eta_{eto}$					-	-	

- ▶  $I...$  [A],  $M...$  [Nm],  $n...$  [r/min],  $P...$  [kW]
- ▶ If the motors are operated at a lower switching frequency, please contact your Lenze sales office!



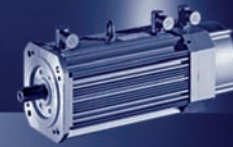

**Mains connection 3 x 400 V and switching frequency  
8 kHz**

**Motors with blower, IP23s**

					EVS	9326-E□	9327-E□	9328-E□	9329-E□	9330-E□	9331-E□	9332-E□
					$I_N$	23.5	32.0	47.0	59.0	89.0	110.0	145.0
					$I_{0,max}$	23.5	32.0	47.0	52.0	80.0	110.0	126.0
MCA	$M_N$	$n_N$	$I_N$	$P_N$	$I_{max}$	35.3	48.0	70.5	88.5	133.5	165.0	217.5
20X14- ...2F□□	61.0	1420	23.0	9.10	$M_0$	61.0	68.0	68.0				
					$M_N$	61.0	61.0	61.0				
					$M_{0,max}$	61.0	93.0	153.0				
					$M_{max}$	109.3	156.7	232.1				
					$\eta_{eto}$	-	-	-				
20X29- ...2F□□	53.5	2930	42.4	16.40	$M_0$		28.0	66.3	68.0	68.0		
					$M_N$		28.0	53.5	53.5	53.5		
					$M_{0,max}$		28.0	66.3	72.0	129.0		
					$M_{max}$		68.5	112.5	146.4	226.7		
					$\eta_{eto}$		-	-	-	-		
22P08- ...2F□□	120.0	760	23.5	9.60	$M_0$	115.0	135.0	135.0	135.0			
					$M_N$	115.0	120.0	120.0	120.0			
					$M_{0,max}$	115.0	166.0	242.0	267.0			
					$M_{max}$	185.0	247.0	338.8	345.8			
					$\eta_{eto}$	-	-	-	-			
22P14- ...2F□□	115.0	1425	40.0	17.20	$M_0$			135.0	135.0	135.0		
					$M_N$			115.0	115.0	115.0		
					$M_{0,max}$			146.0	160.0	264.0		
					$M_{max}$			230.1	292.9	341.8		
					$\eta_{eto}$			-	-	-		
22P17- ...2F□□	112.0	1670	44.5	19.60	$M_0$			124.0	134.0	135.0	135.0	
					$M_N$			112.0	112.0	112.0	112.0	
					$M_{0,max}$			124.0	140.0	240.0	335.0	
					$M_{max}$			180.5	227.7	342.1	378.3	
					$\eta_{eto}$			-	-	-	-	
22P29- ...2F□□	110.0	2935	77.8	33.80	$M_0$					118.0	135.0	135.0
					$M_N$					110.0	110.0	110.0
					$M_{0,max}$					122.0	171.0	200.0
					$M_{max}$					215.6	273.1	355.1
					$\eta_{eto}$					-	-	-
26T05- ...2F□□	280.0	550	42.4	16.10	$M_0$		191.0	290.0	290.0	290.0		
					$M_N$		191.0	280.0	280.0	280.0		
					$M_{0,max}$		191.0	303.0	333.0	615.0		
					$M_{max}$		313.0	482.0	612.0	751.0		
					$\eta_{eto}$		-	-	-	-		
26T10- ...2F□□	260.0	1030	69.6	28.00	$M_0$				159.0	290.0	290.0	
					$M_N$				197.0	260.0	260.0	
					$M_{0,max}$				159.0	300.0	440.0	
					$M_{max}$				343.0	552.0	671.0	
					$\eta_{eto}$				-	-	-	
26T12- ...2F□□	255.0	1200	83.3	32.00	$M_0$					232.0	290.0	290.0
					$M_N$				255.0	255.0	255.0	
					$M_{0,max}$				258.0	327.0	397.0	
					$M_{max}$				424.0	512.0	663.0	
					$\eta_{eto}$				-	-	-	
26T22- ...2F□□	230.0	2235	126.7	53.80	$M_0$						177.0	222.0
					$M_N$				177.0	230.0		
					$M_{0,max}$				203.0	220.0		
					$M_{max}$				315.0	432.0		
					$\eta_{eto}$				-	-	-	

- ▶  $I...$  [A],  $M...$  [Nm],  $n...$  [r/min],  $P...$  [kW]
- ▶ If the motors are operated at a lower switching frequency, please contact your Lenze sales office!

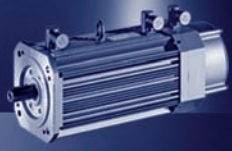

## MCA asynchronous servo motors

### Torque characteristics

Mains connection 3x 400 V

MCA10I40

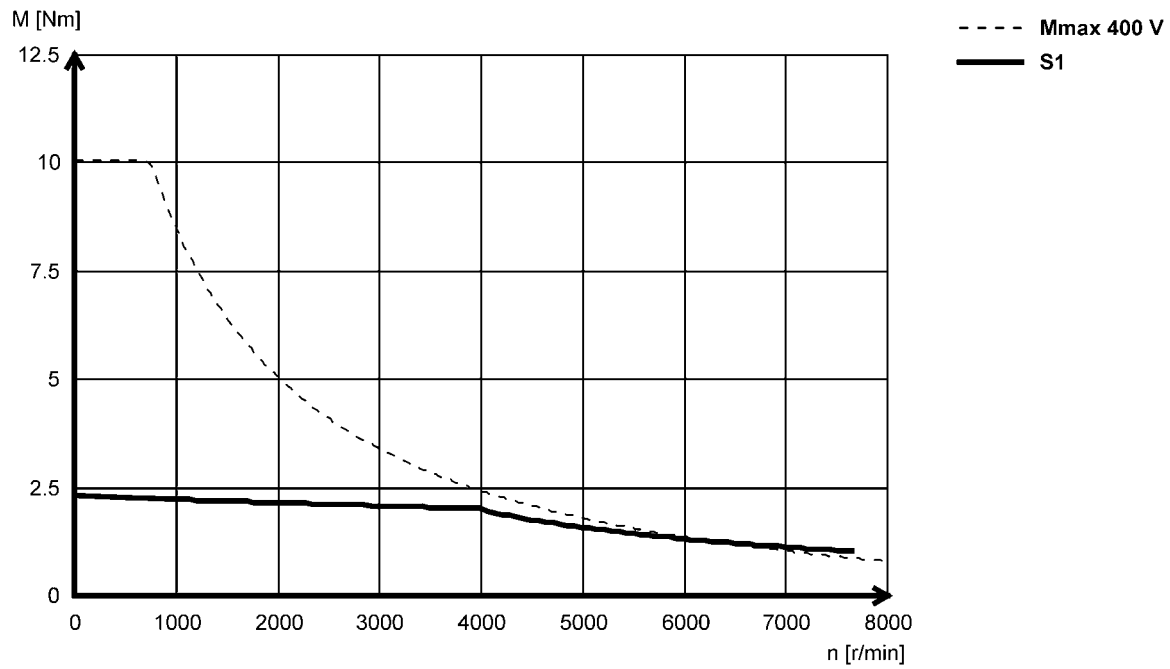

- ▶ Other torque characteristics with Lenze inverters can be found at [www.lenze.de/dsc](http://www.lenze.de/dsc).

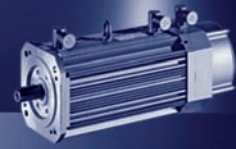

Mains connection 3x 400 V

### MCA13I34

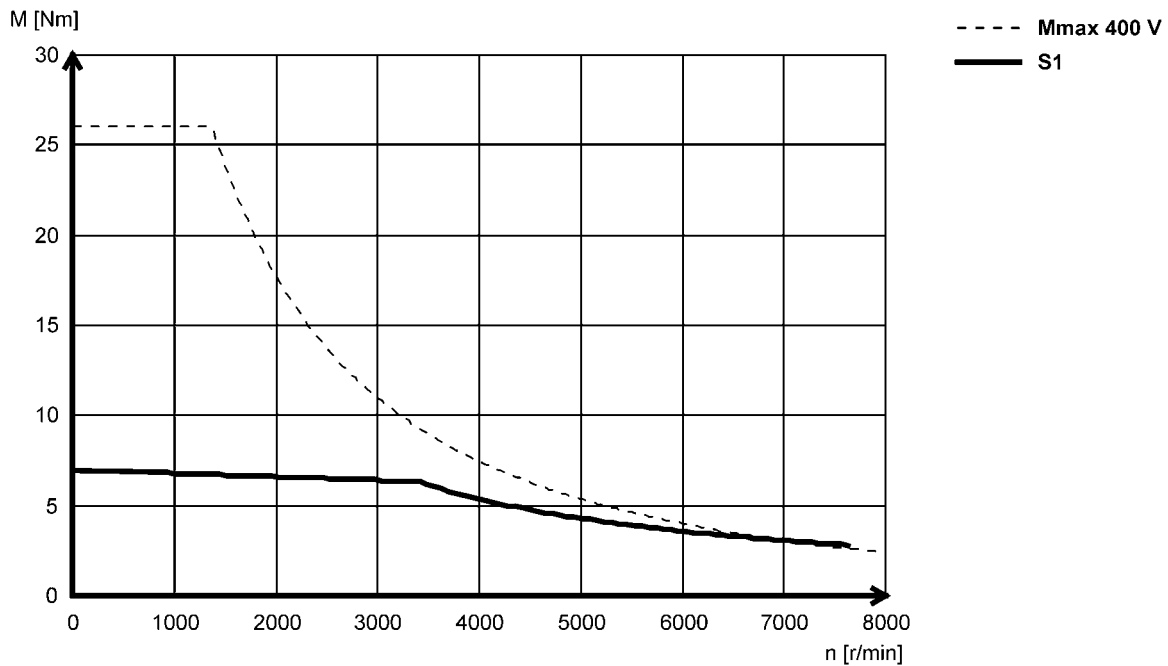

### MCA13I41

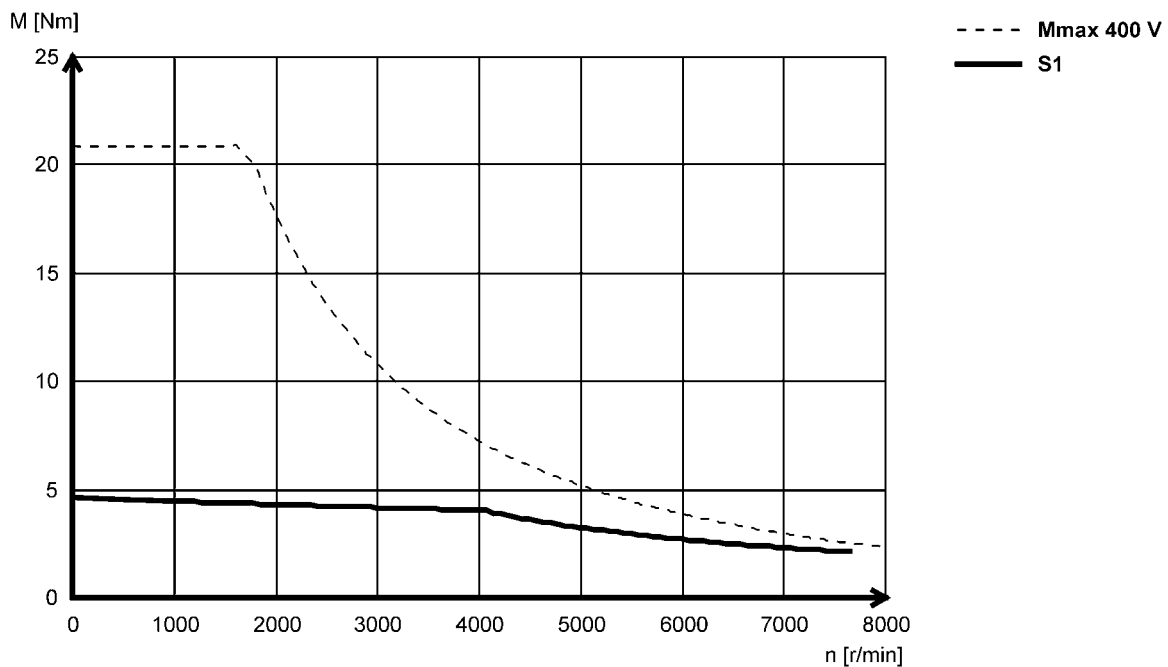

► Other torque characteristics with Lenze inverters can be found at [www.lenze.de/dsc](http://www.lenze.de/dsc).

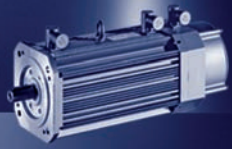

# MCA asynchronous servo motors

## Torque characteristics

Mains connection 3x 400 V

### MCA14L16

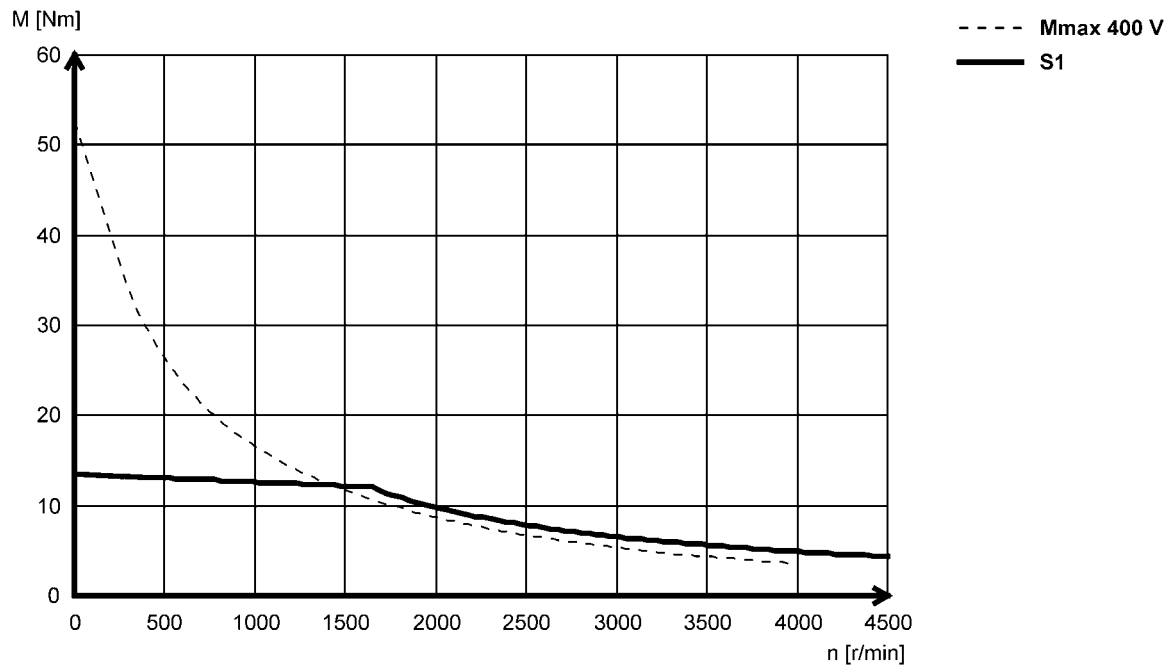

### MCA14L20

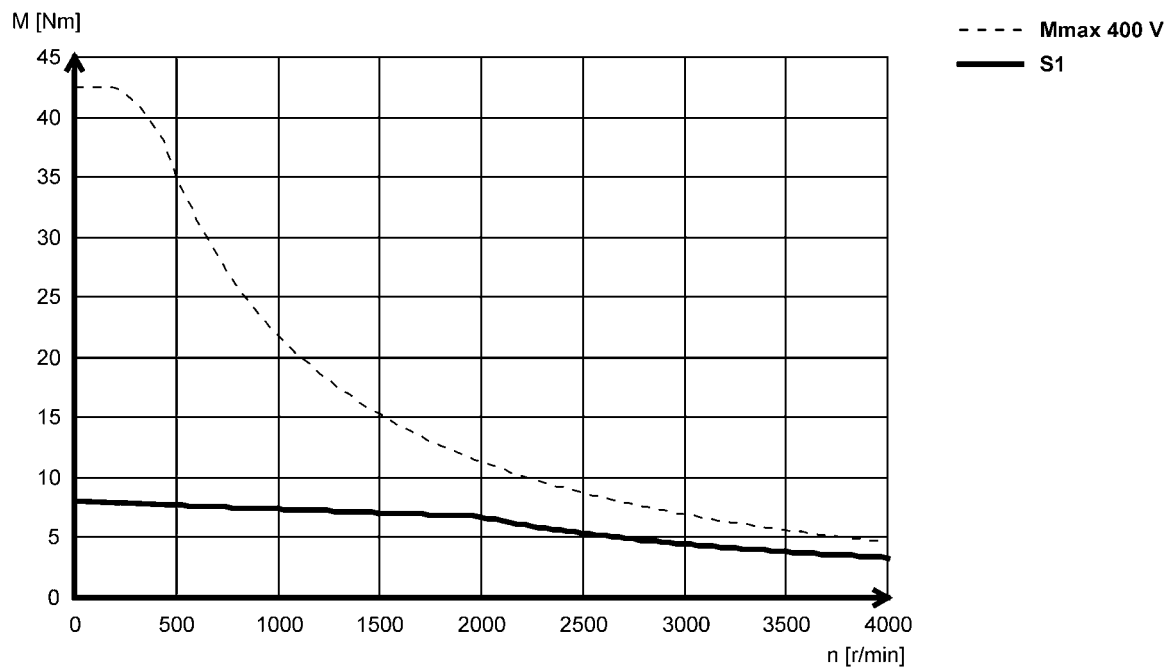

► Other torque characteristics with Lenze inverters can be found at [www.lenze.de/dsc](http://www.lenze.de/dsc).

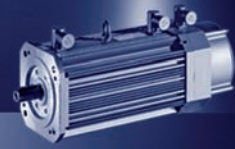

Mains connection 3x 400 V

### MCA14L35

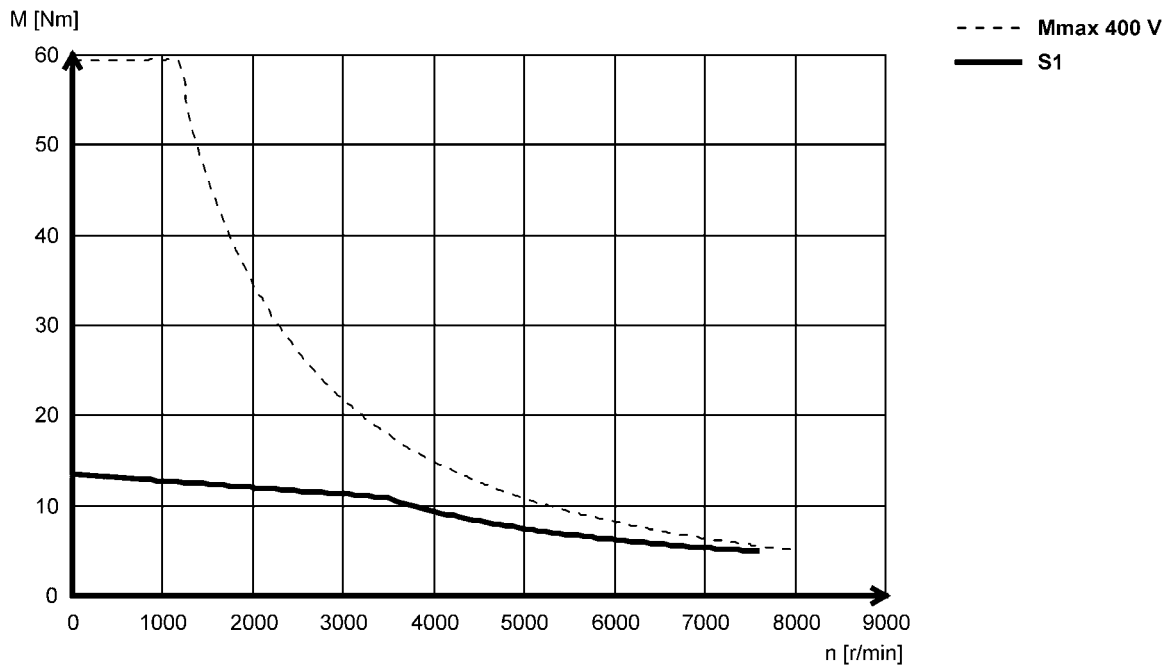

### MCA14L41

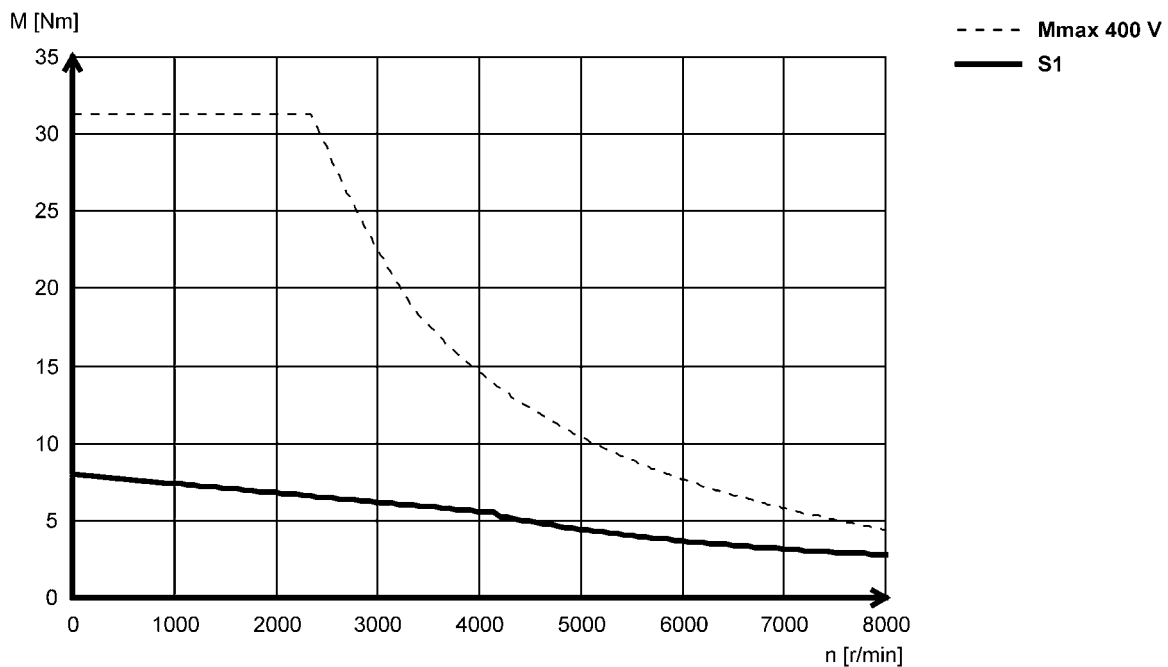

► Other torque characteristics with Lenze inverters can be found at [www.lenze.de/dsc](http://www.lenze.de/dsc).

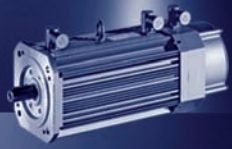

# MCA asynchronous servo motors

## Torque characteristics

Mains connection 3x 400 V

### MCA17N17

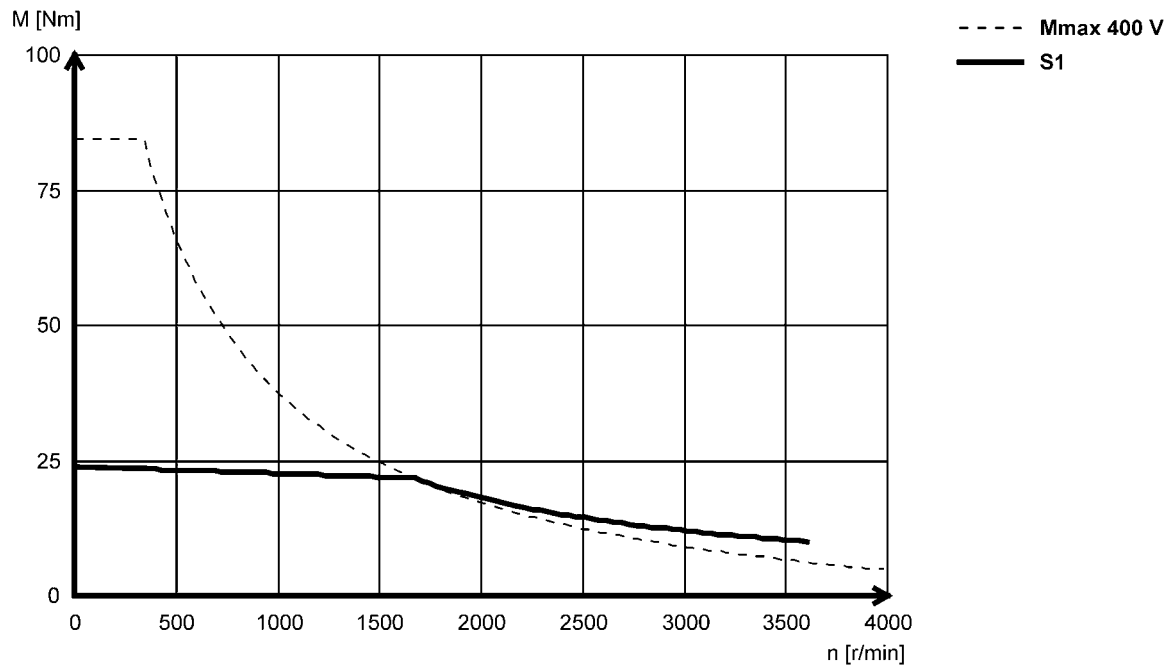

### MCA17N23

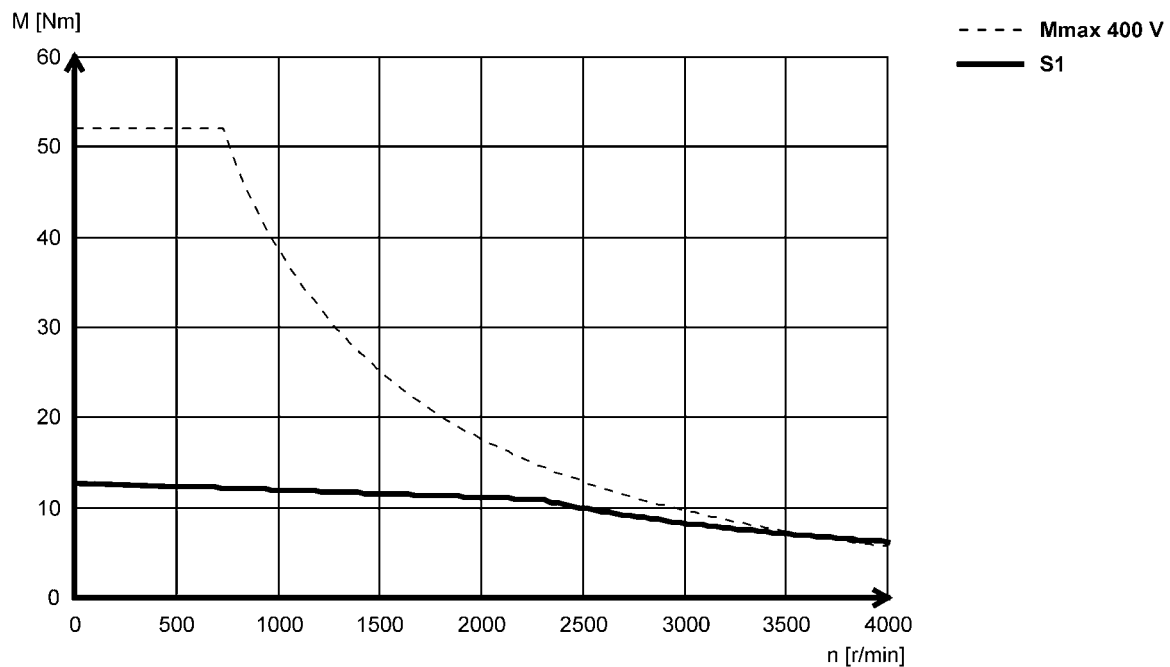

► Other torque characteristics with Lenze inverters can be found at [www.lenze.de/dsc](http://www.lenze.de/dsc).

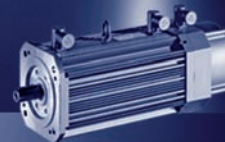

Mains connection 3x 400 V

### MCA17N35

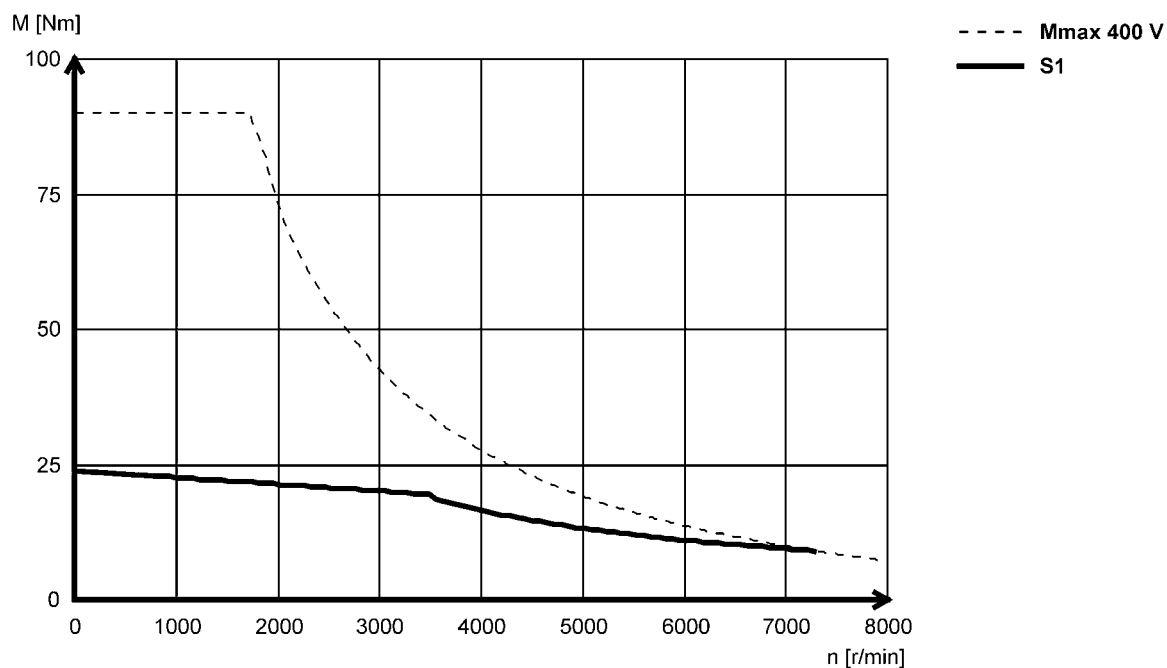

### MCA17N41

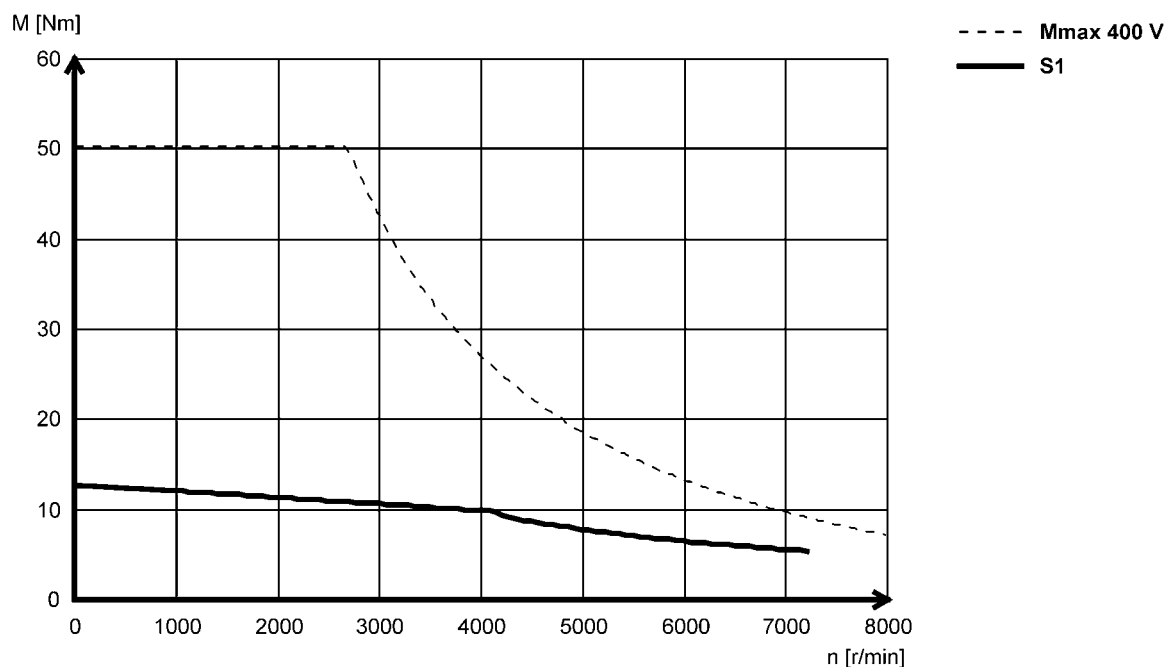

► Other torque characteristics with Lenze inverters can be found at [www.lenze.de/dsc](http://www.lenze.de/dsc).

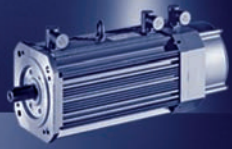

# MCA asynchronous servo motors

## Torque characteristics

Mains connection 3x 400 V

### MCA19S17

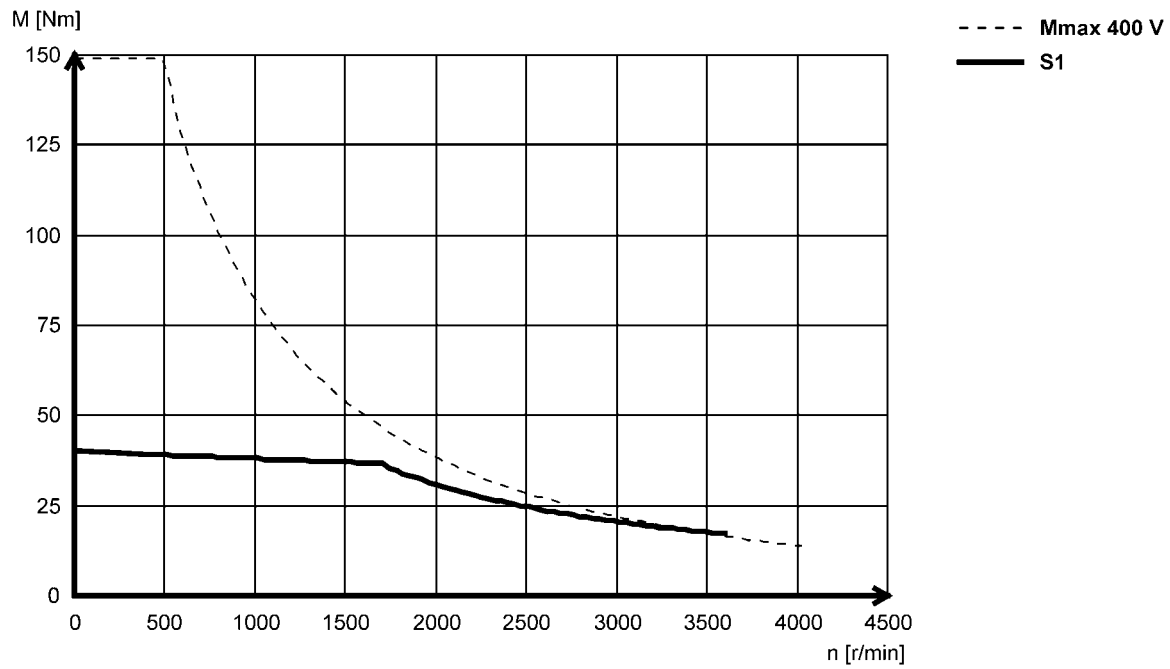

### MCA19S23

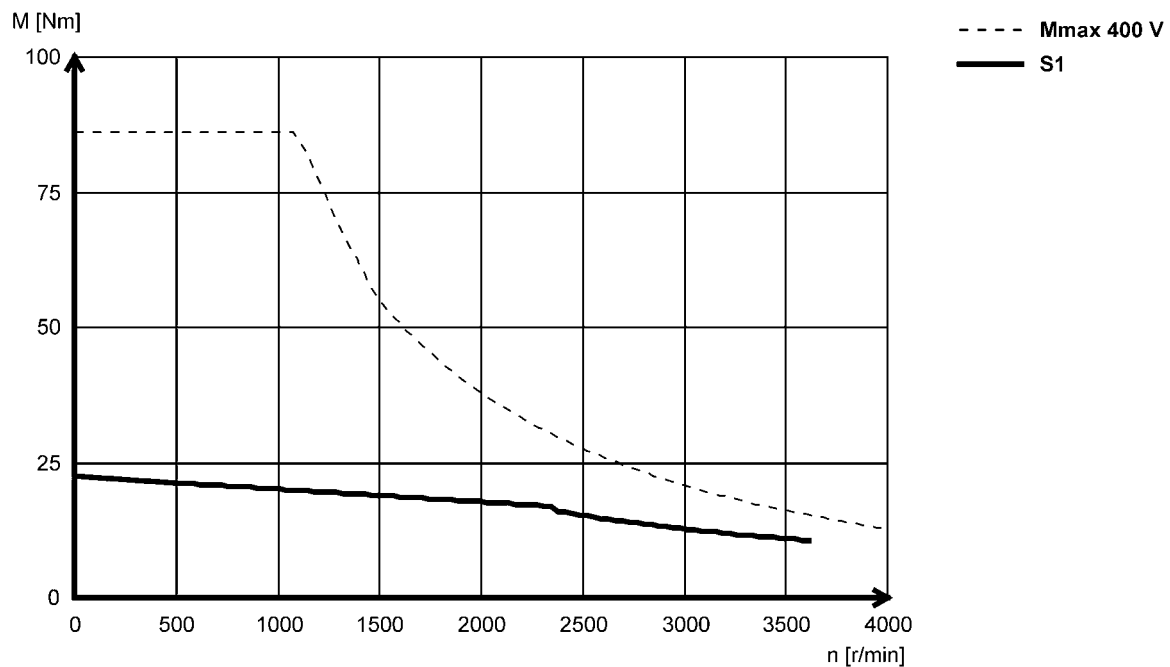

► Other torque characteristics with Lenze inverters can be found at [www.lenze.de/dsc](http://www.lenze.de/dsc).



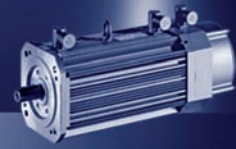

Mains connection 3x 400 V

**MCA19S35**

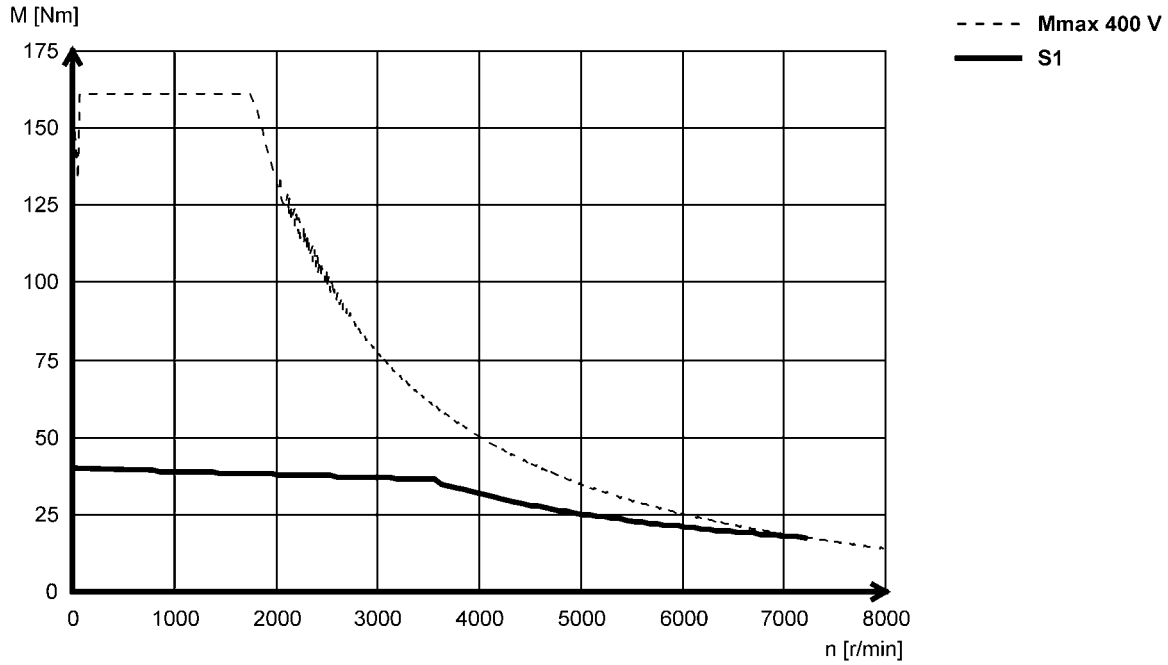

**MCA19S42**

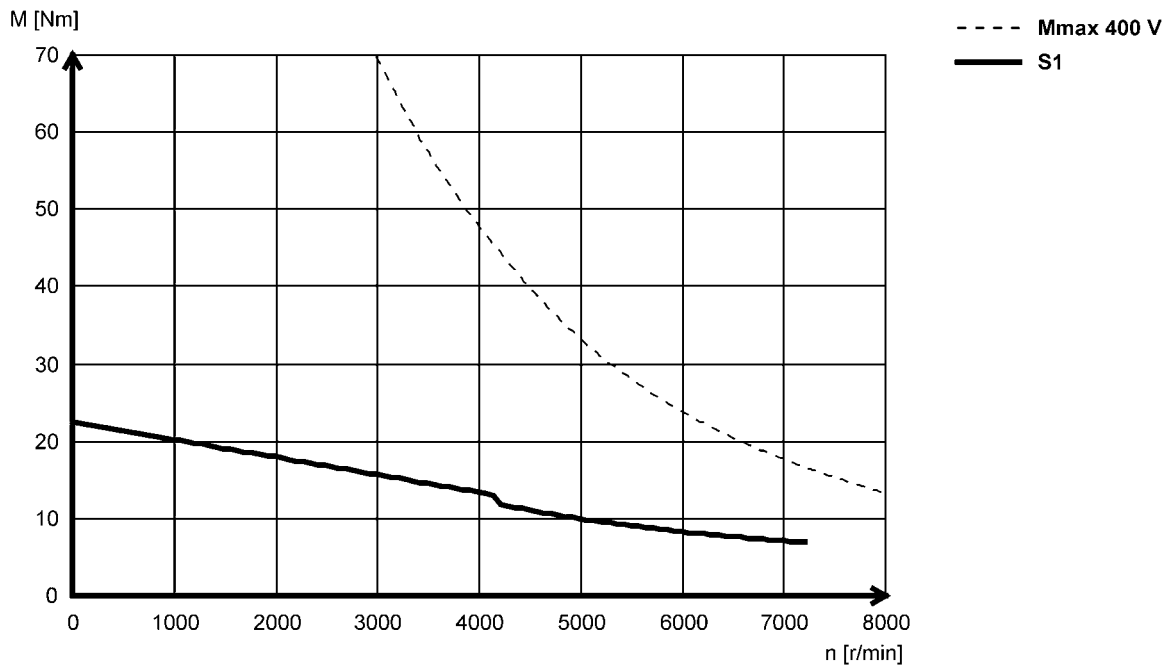

► Other torque characteristics with Lenze inverters can be found at [www.lenze.de/dsc](http://www.lenze.de/dsc).

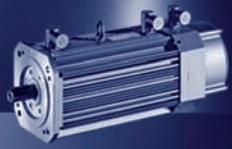

# MCA asynchronous servo motors

## Torque characteristics

Mains connection 3x 400 V

MCA20X14...2F□□

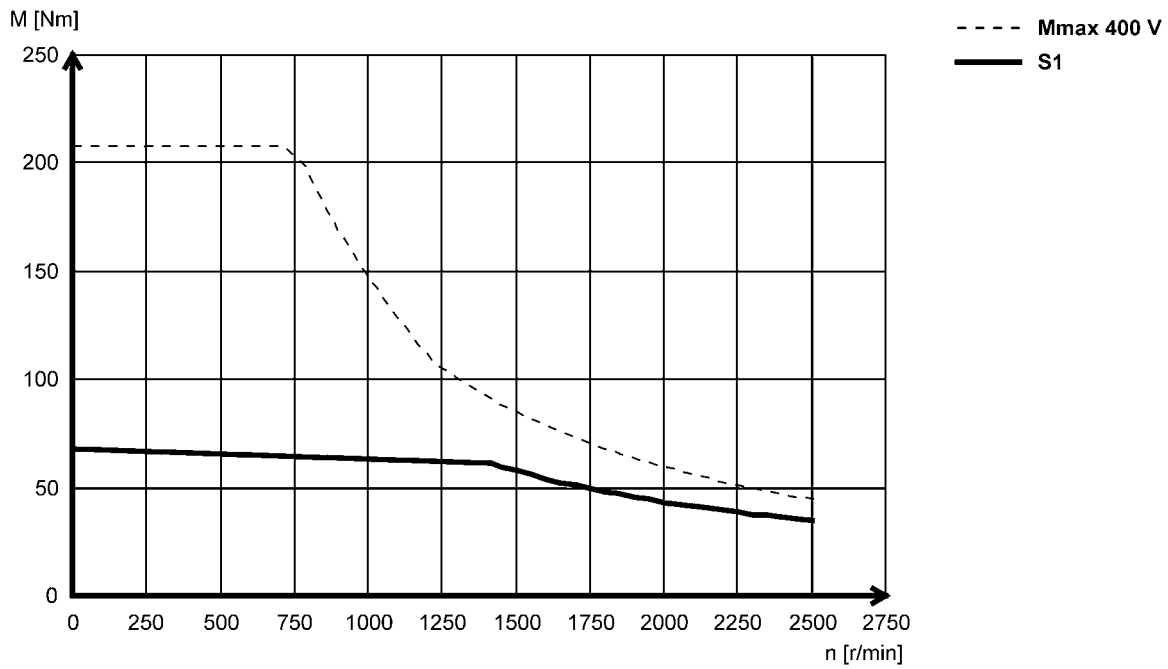

MCA20X29...2F□□

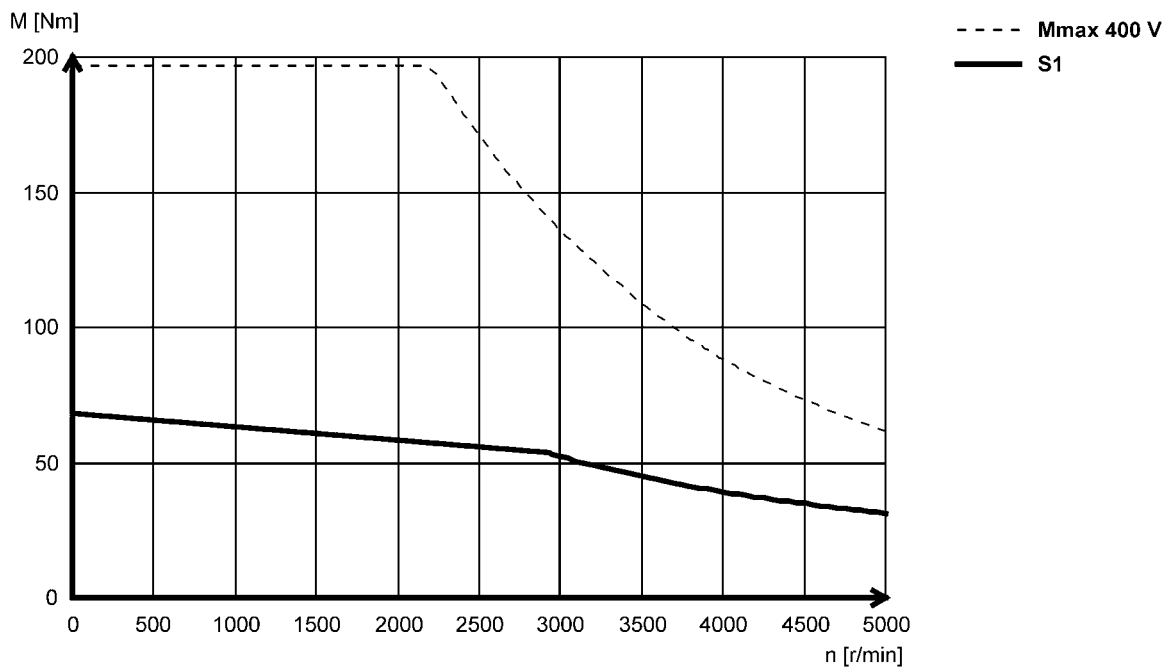

► Other torque characteristics with Lenze inverters can be found at [www.lenze.de/dsc](http://www.lenze.de/dsc).

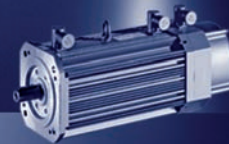

Mains connection 3x 400 V

### MCA21X17

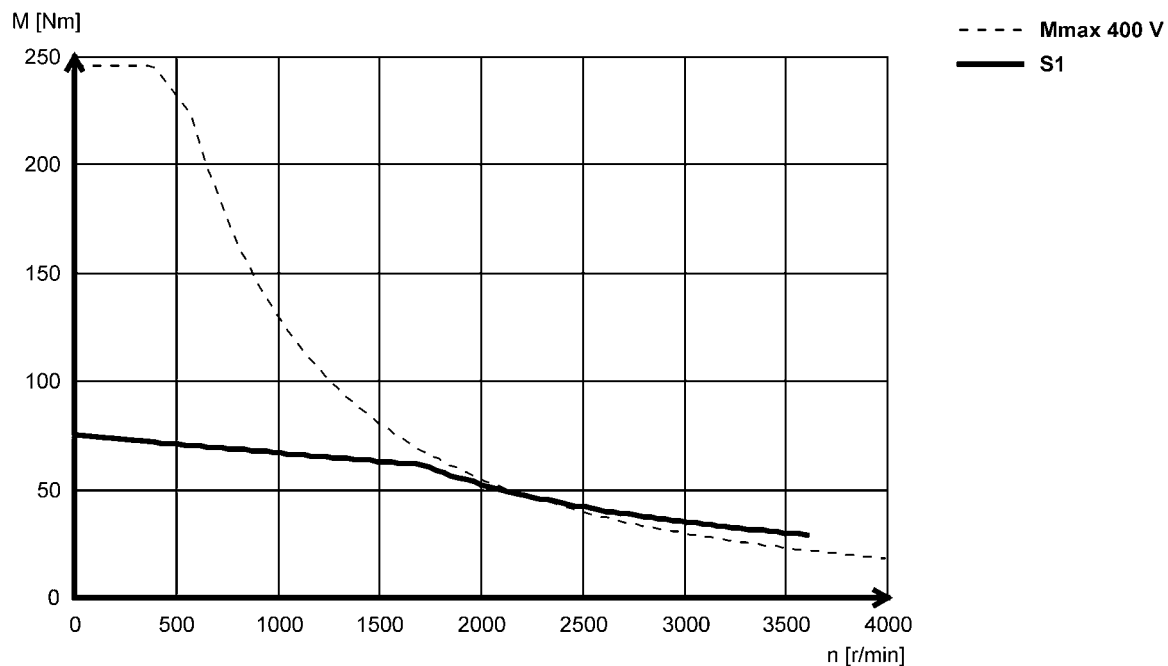

### MCA21X25

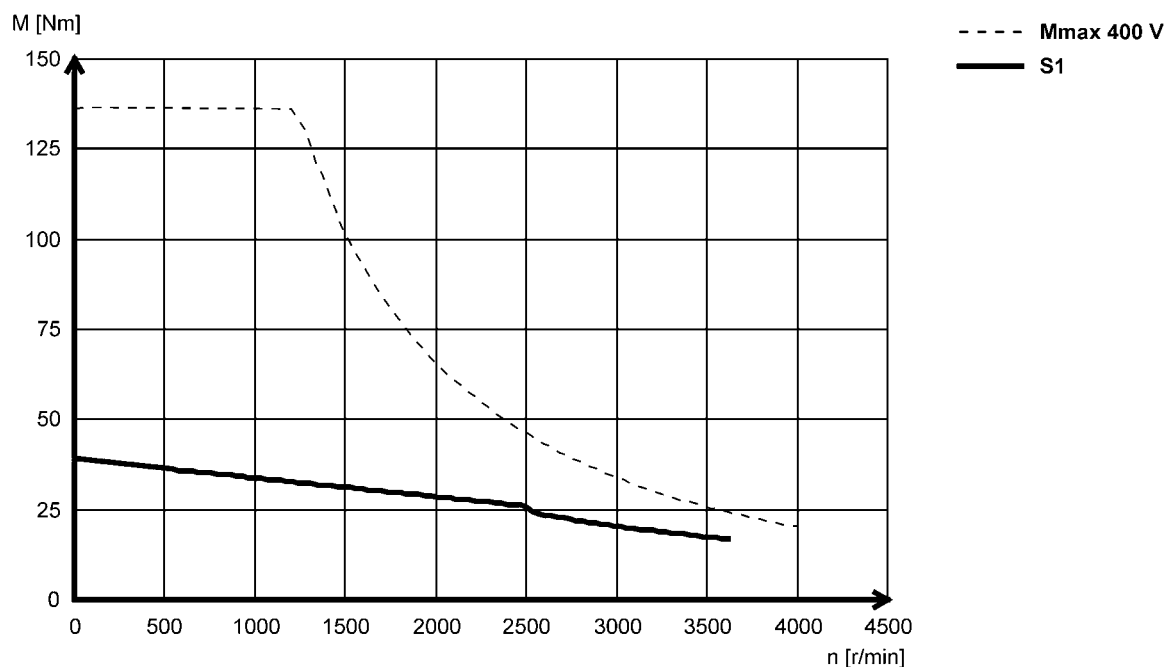

► Other torque characteristics with Lenze inverters can be found at [www.lenze.de/dsc](http://www.lenze.de/dsc).

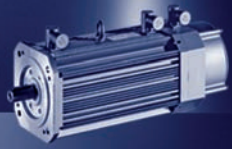

# MCA asynchronous servo motors

## Torque characteristics

Mains connection 3x 400 V

### MCA21X35

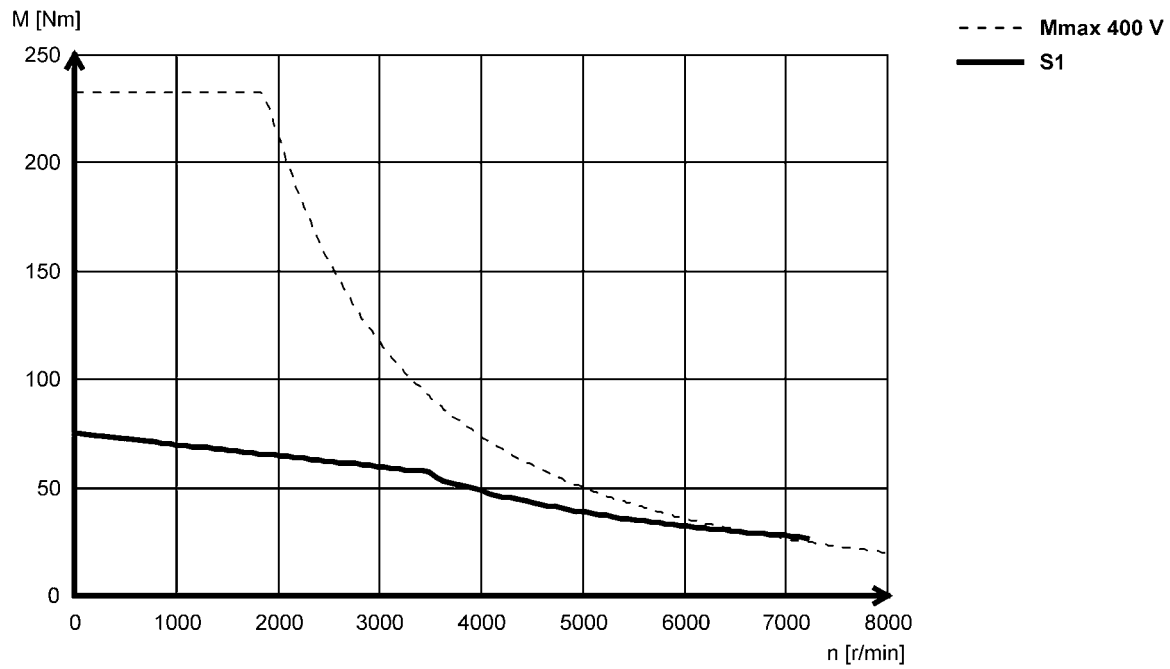

### MCA21X42

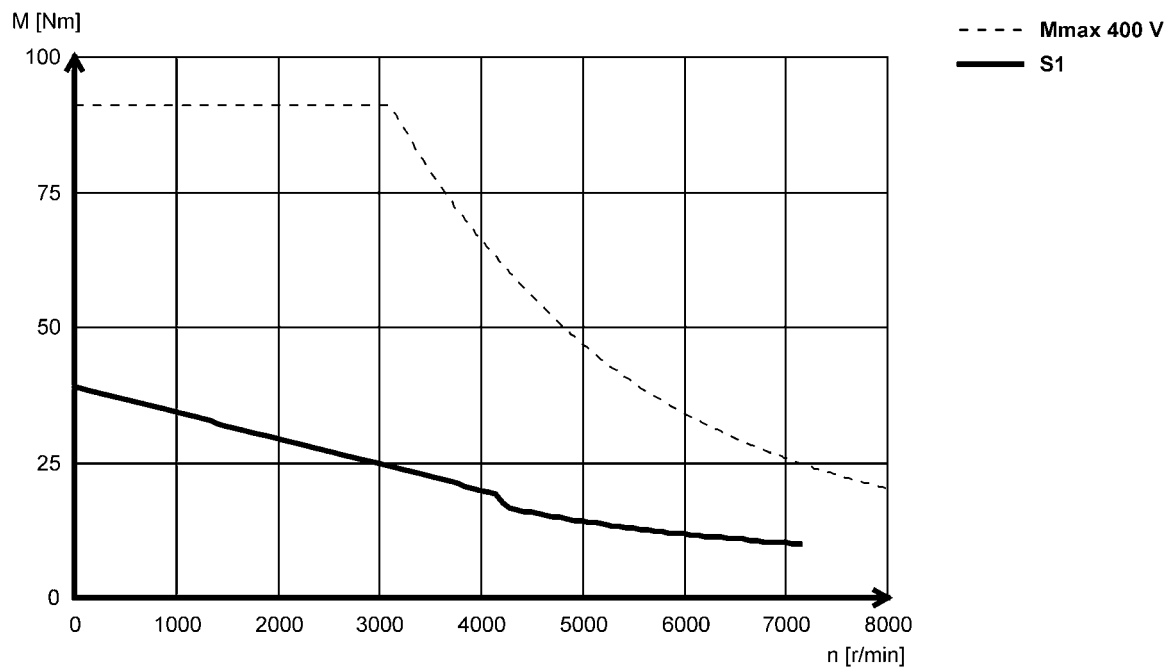

► Other torque characteristics with Lenze inverters can be found at [www.lenze.de/dsc](http://www.lenze.de/dsc).

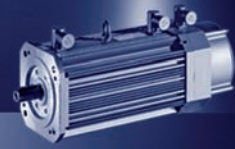

Mains connection 3x 400 V

MCA22P08...5F□□

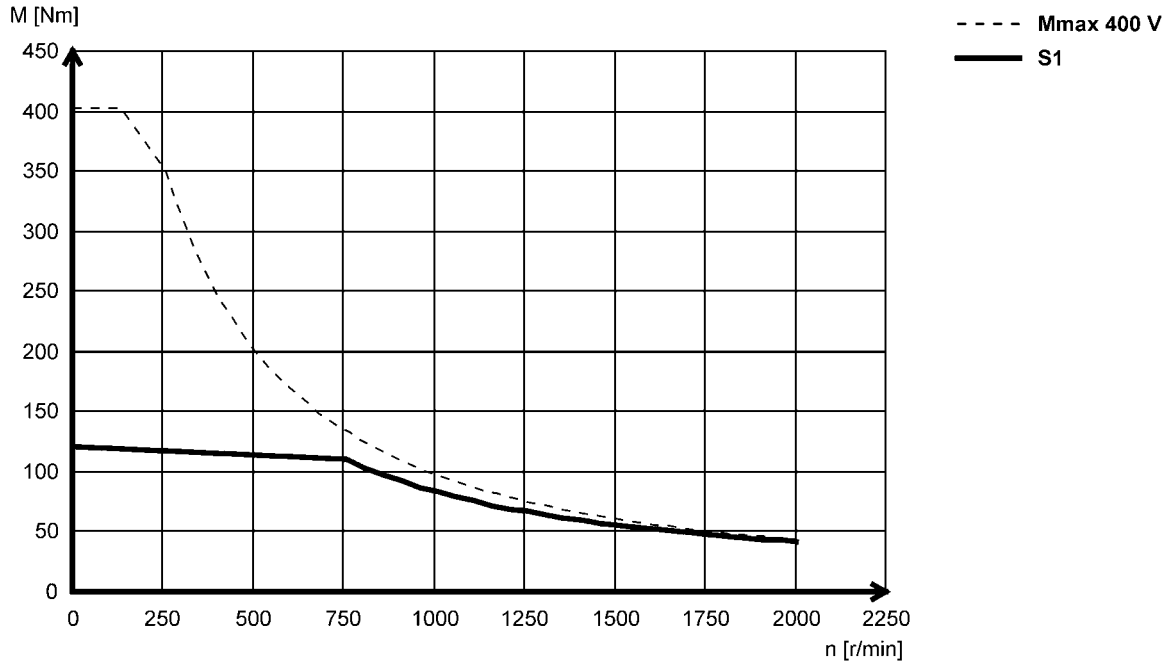

MCA22P08...2F□□

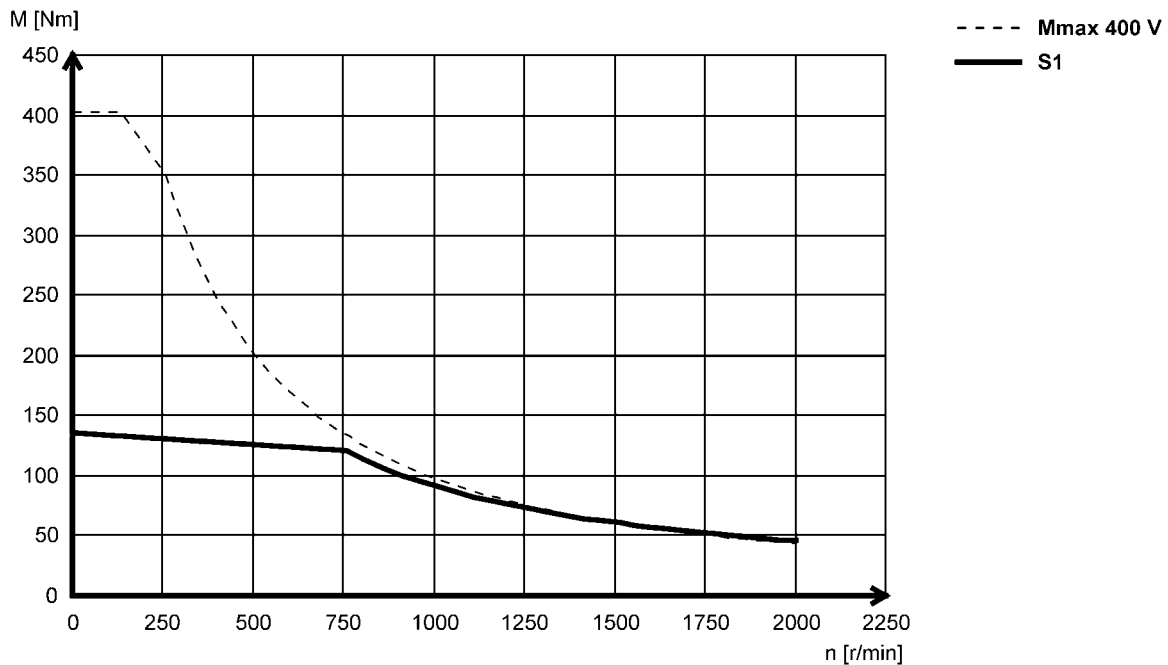

► Other torque characteristics with Lenze inverters can be found at [www.lenze.de/dsc](http://www.lenze.de/dsc).

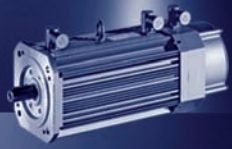

# MCA asynchronous servo motors

## Torque characteristics

Mains connection 3x 400 V

MCA22P14...5F□□

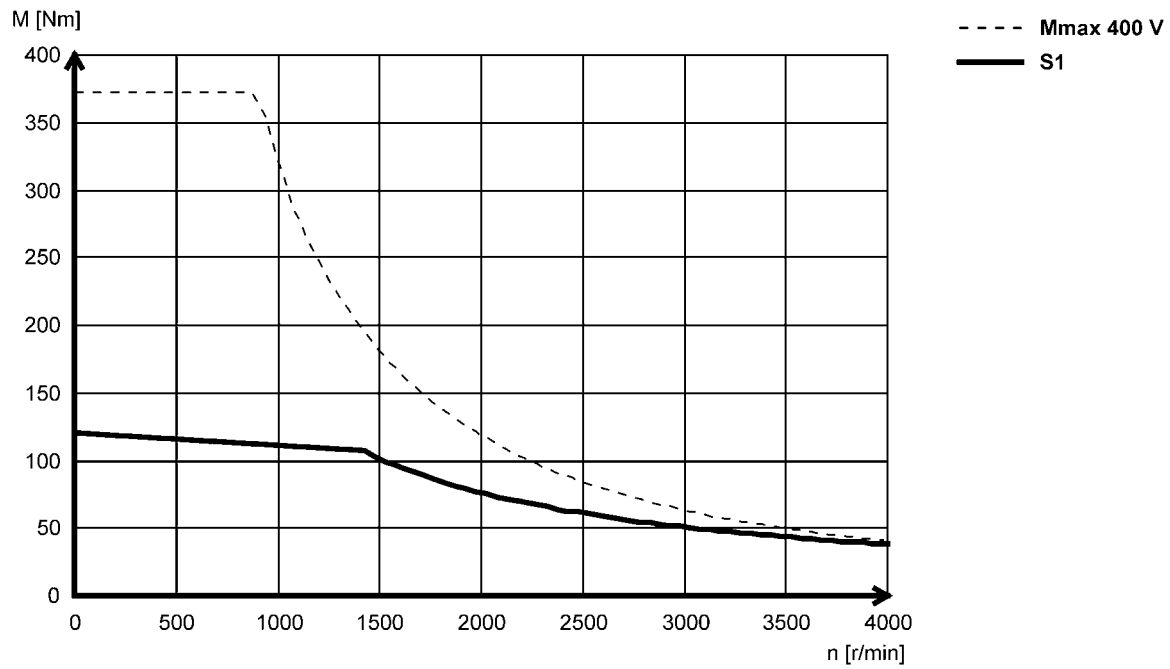

MCA22P14...2F□□

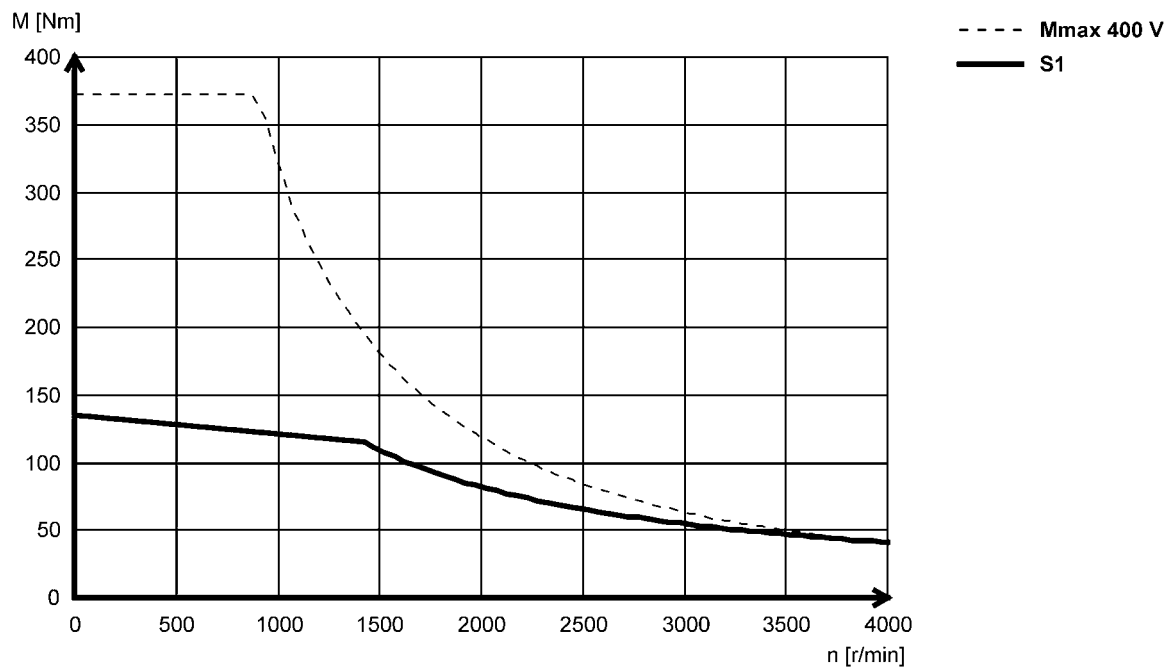

► Other torque characteristics with Lenze inverters can be found at [www.lenze.de/dsc](http://www.lenze.de/dsc).

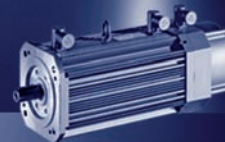

Mains connection 3x 400 V

MCA22P17...5F□□

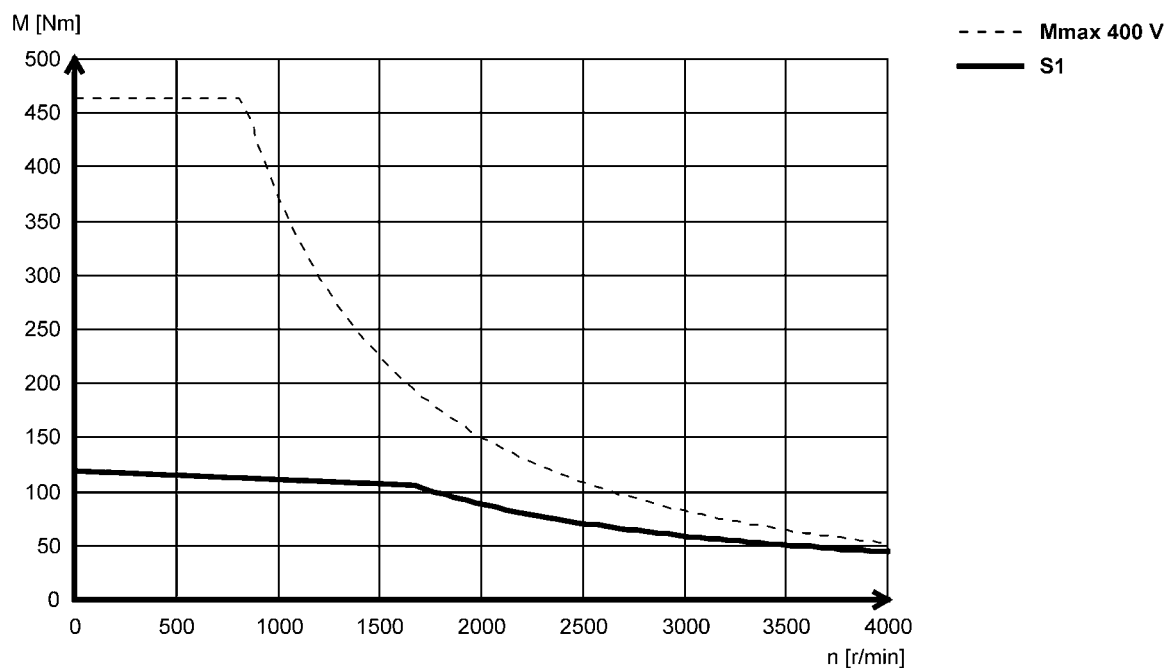

MCA22P17...2F□□

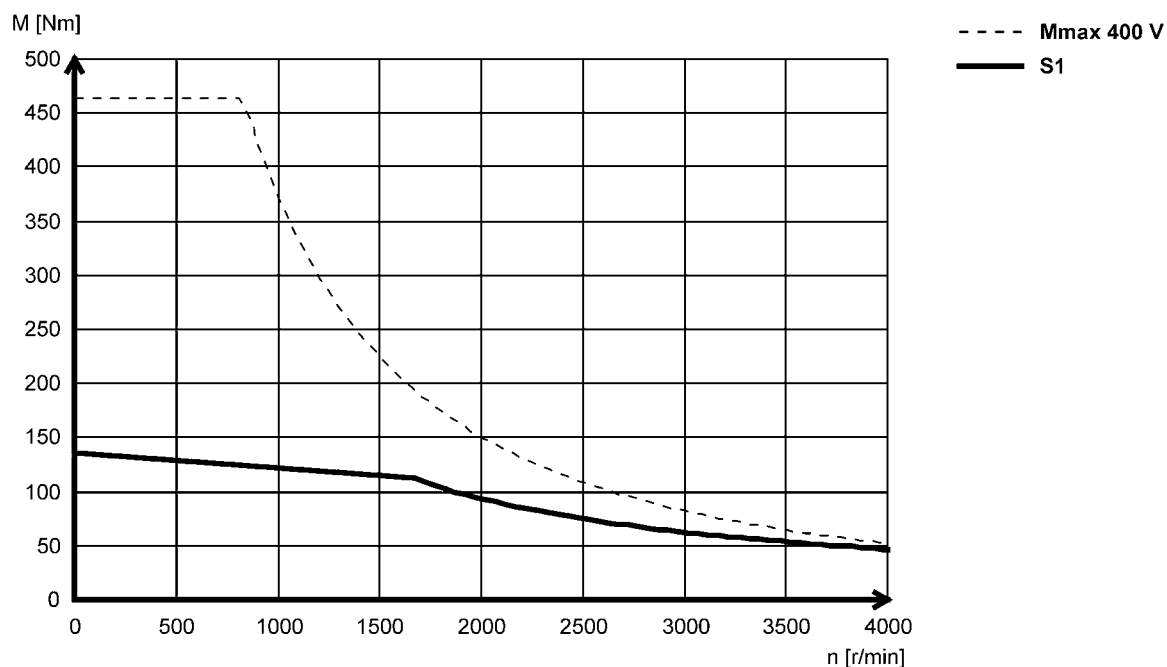

► Other torque characteristics with Lenze inverters can be found at [www.lenze.de/dsc](http://www.lenze.de/dsc).

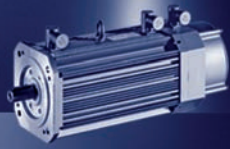

# MCA asynchronous servo motors

## Torque characteristics

Mains connection 3x 400 V

MCA22P29...5F□□

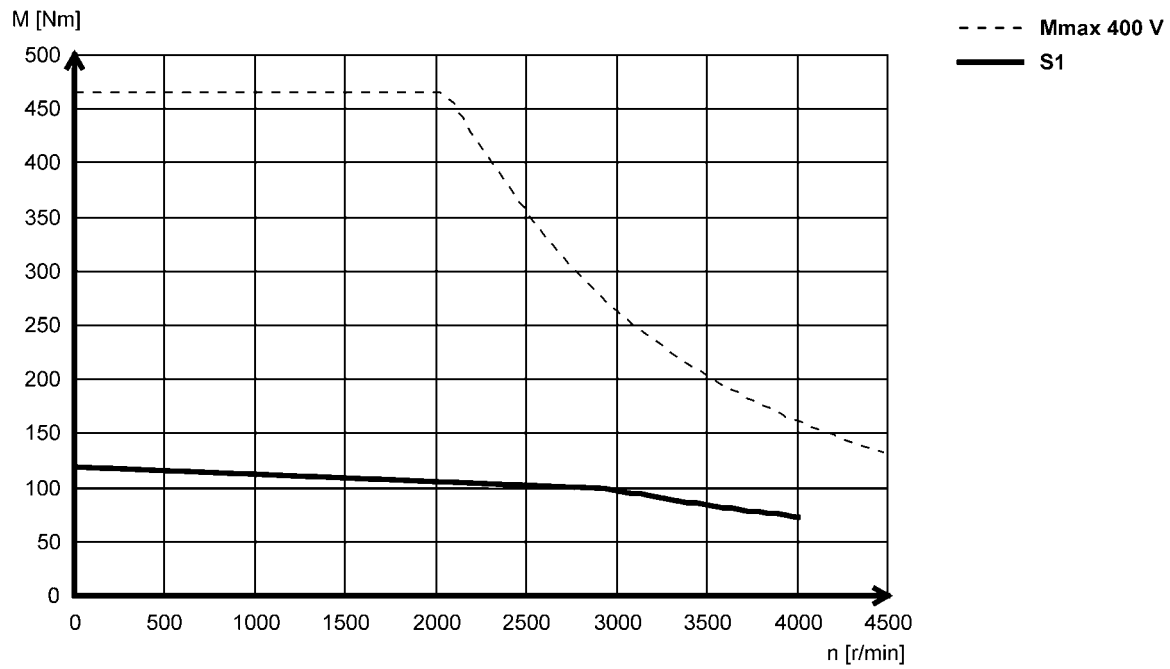

MCA22P29...2F□□

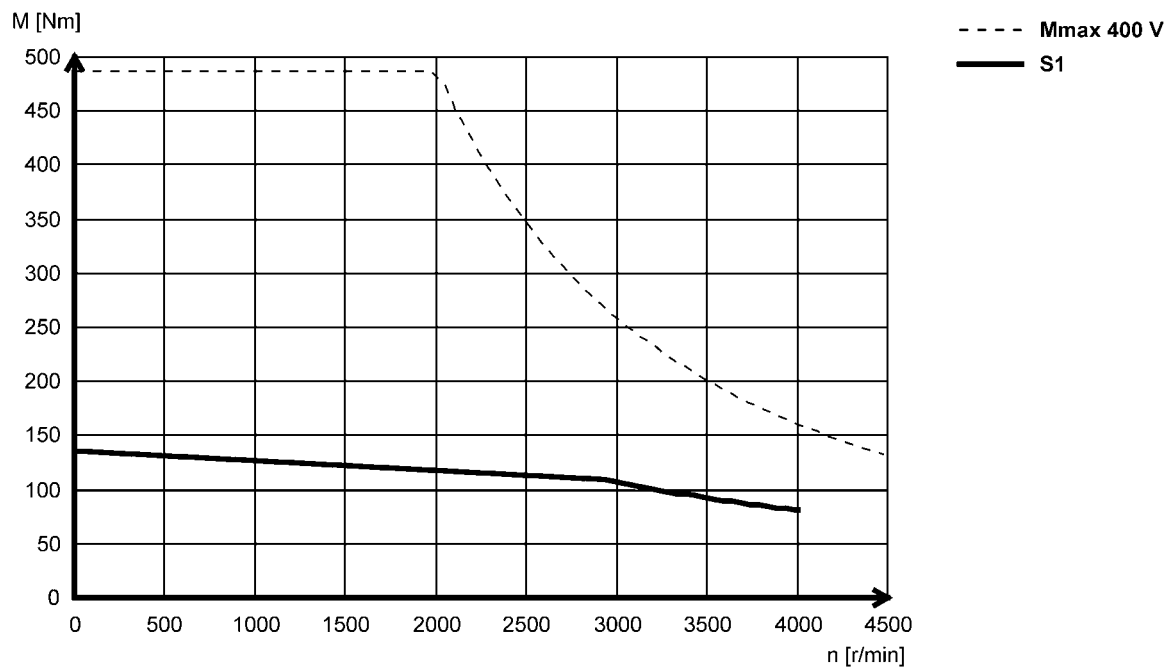

► Other torque characteristics with Lenze inverters can be found at [www.lenze.de/dsc](http://www.lenze.de/dsc).



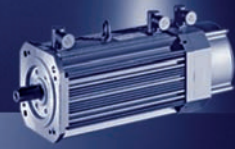

Mains connection 3x 400 V

MCA26T05...5F□□

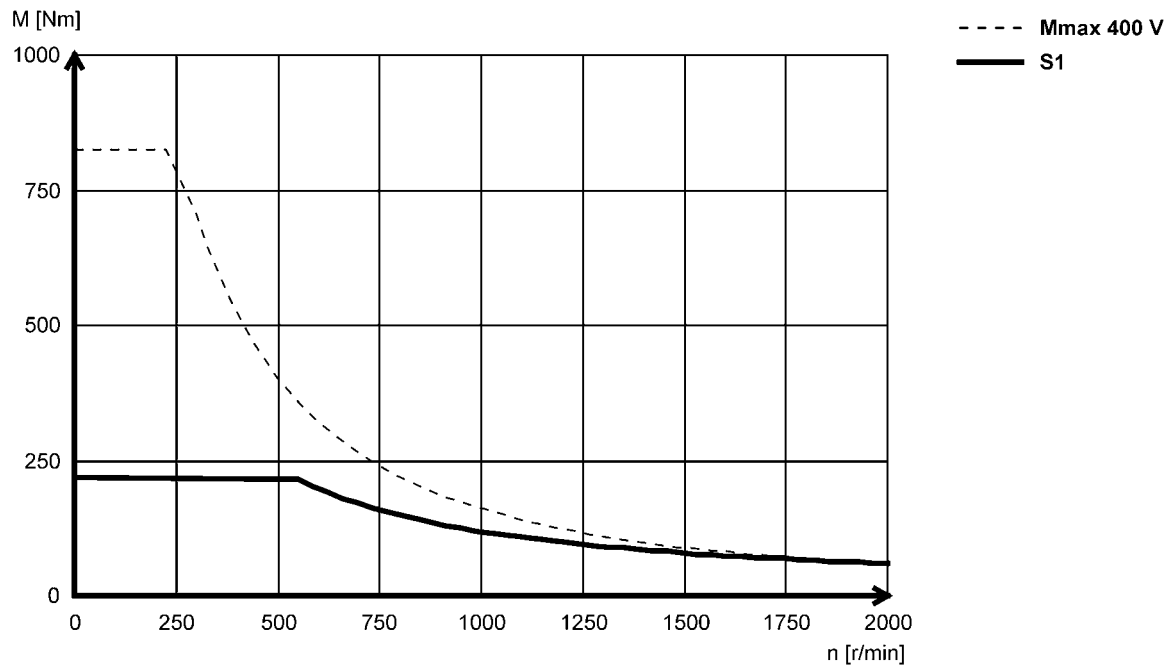

MCA26T05...2F□□

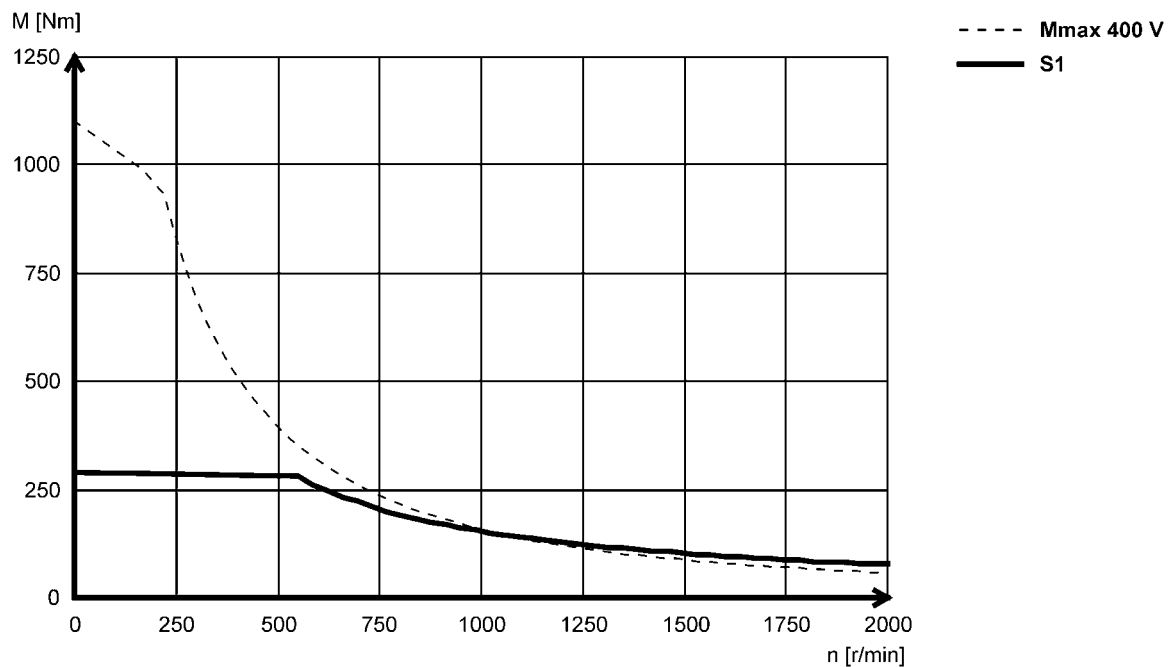

► Other torque characteristics with Lenze inverters can be found at [www.lenze.de/dsc](http://www.lenze.de/dsc).

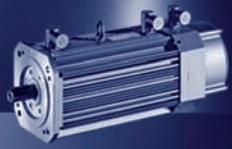

# MCA asynchronous servo motors

## Torque characteristics

Mains connection 3x 400 V

MCA26T10...5F□□

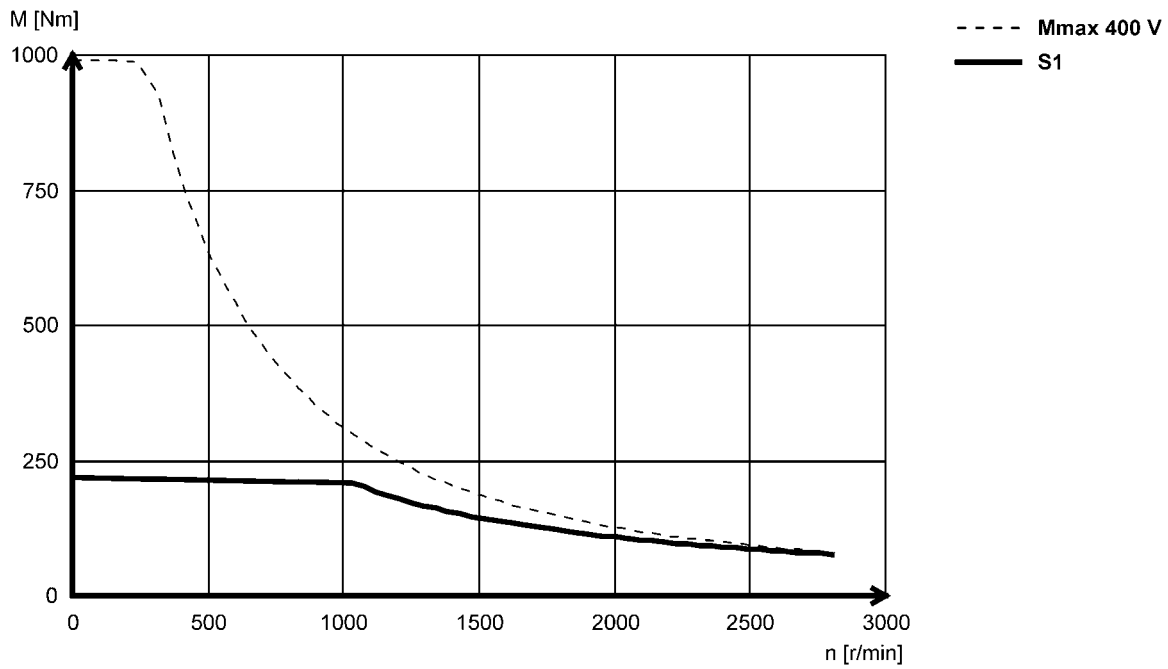

MCA26T10...2F□□

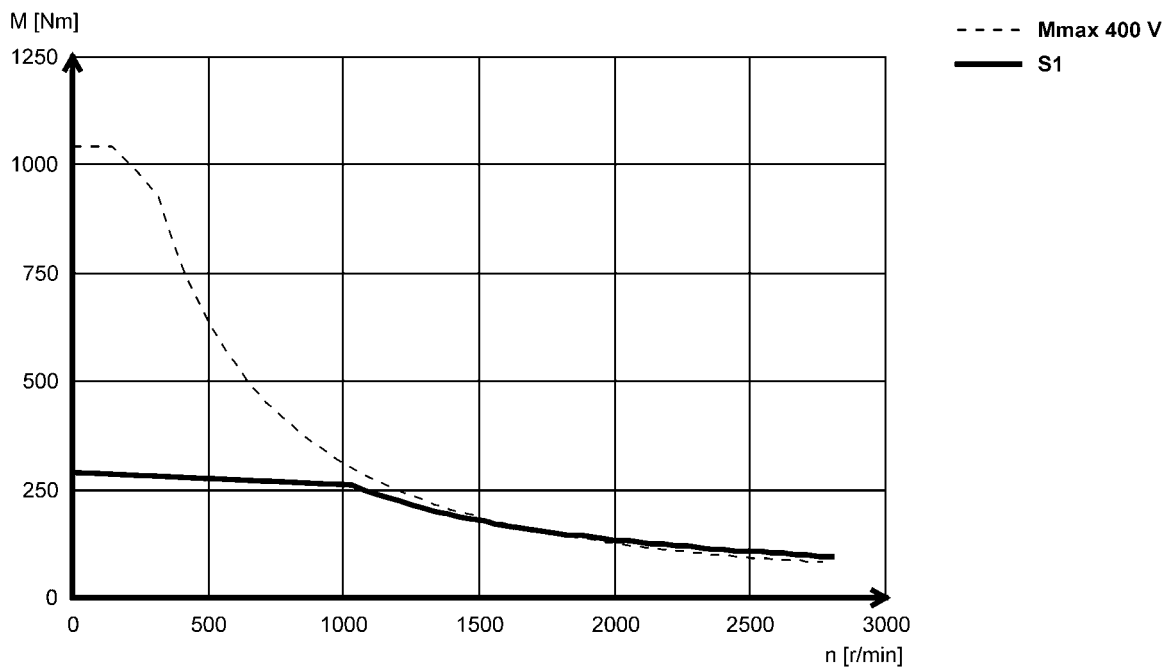

► Other torque characteristics with Lenze inverters can be found at [www.lenze.de/dsc](http://www.lenze.de/dsc).

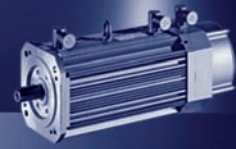

Mains connection 3x 400 V

MCA26T12...5F□□

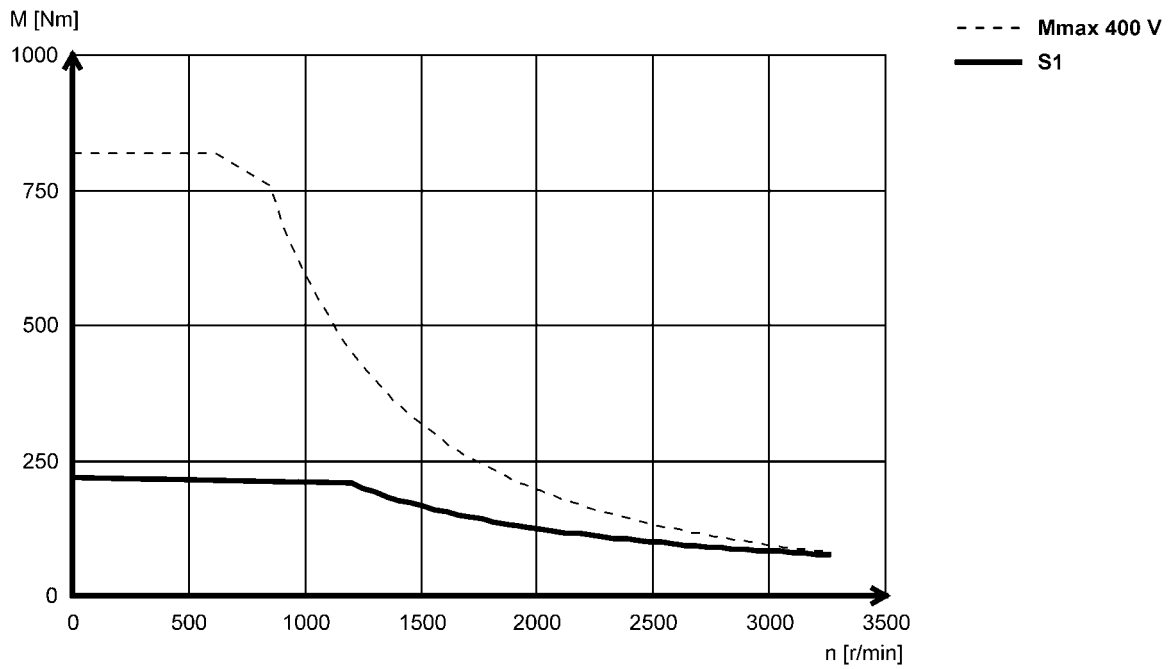

MCA26T12...2F□□

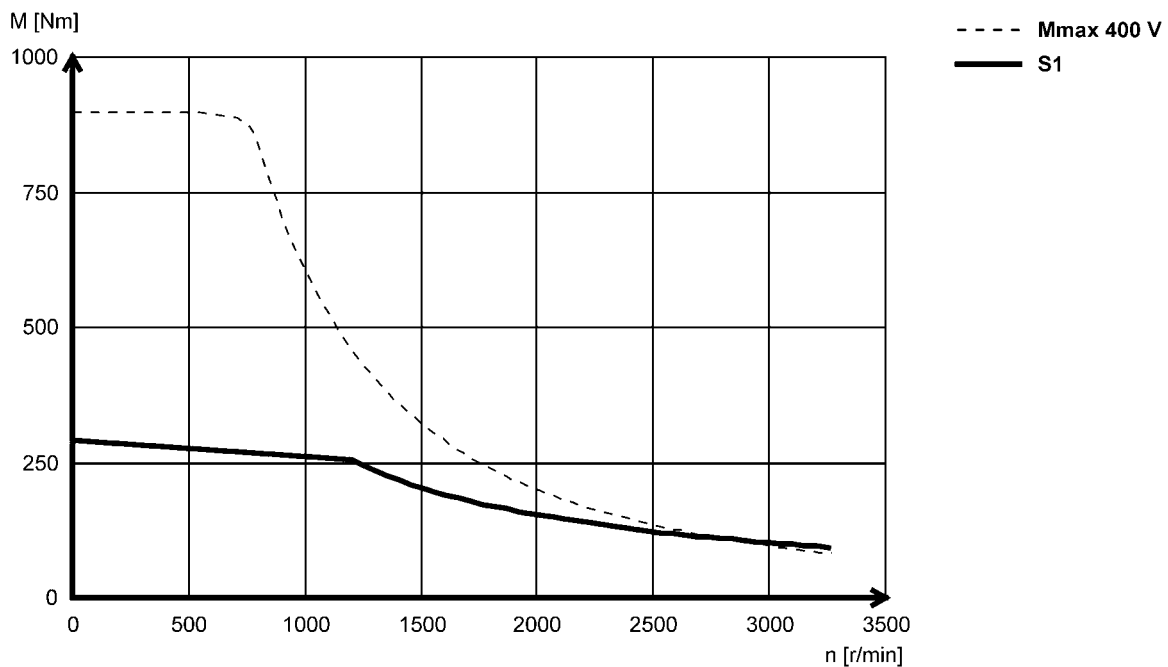

► Other torque characteristics with Lenze inverters can be found at [www.lenze.de/dsc](http://www.lenze.de/dsc).

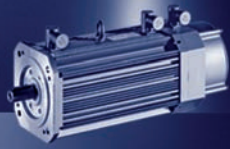

# MCA asynchronous servo motors

## Torque characteristics

Mains connection 3x 400 V

MCA26T22...5F□□

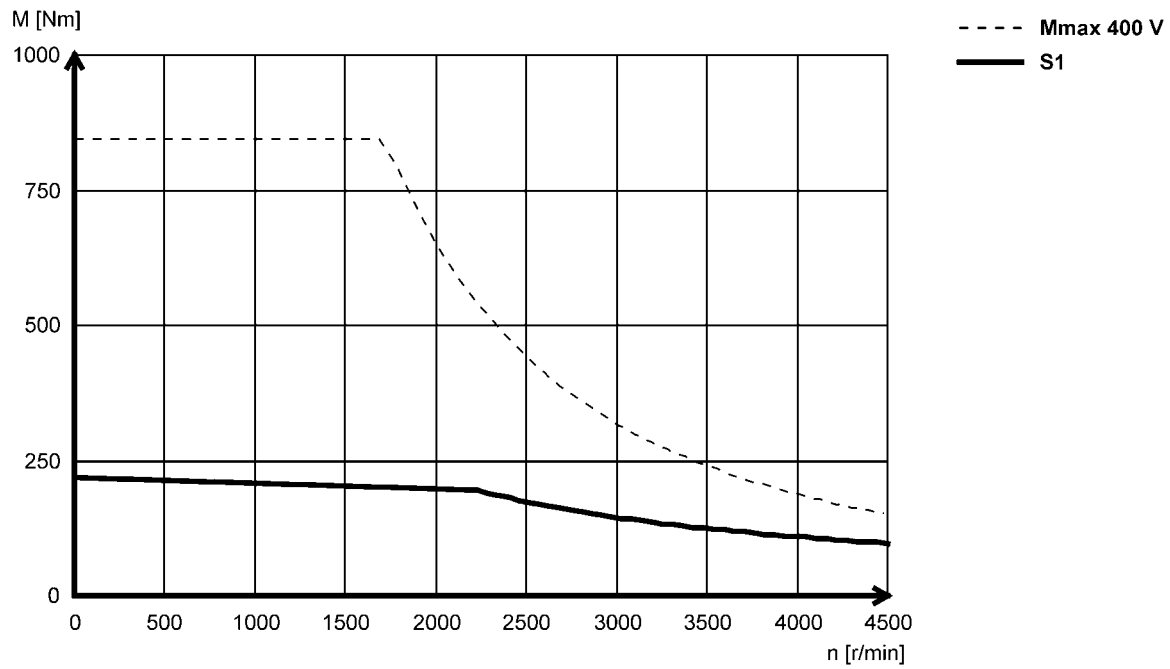

MCA26T22...2F□□

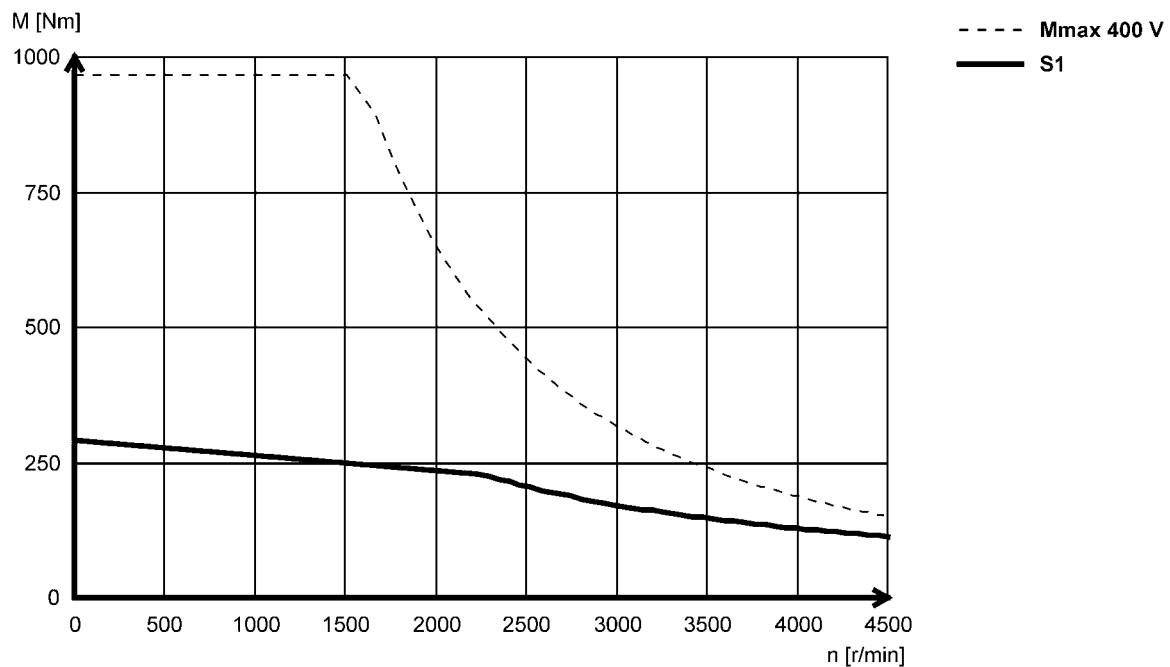

► Other torque characteristics with Lenze inverters can be found at [www.lenze.de/dsc](http://www.lenze.de/dsc).

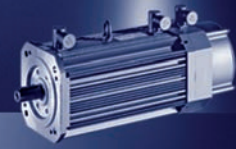

## Motor connection terminal box

If a servo motor is to be connected to an existing cable or plug connectors are not to be used for other reasons, the connection can also be made via a terminal box.

The motor can either be fitted with a terminal box for the power connection and motor holding brake or a second terminal box provided to connect the motor feedback and blower (if applicable).

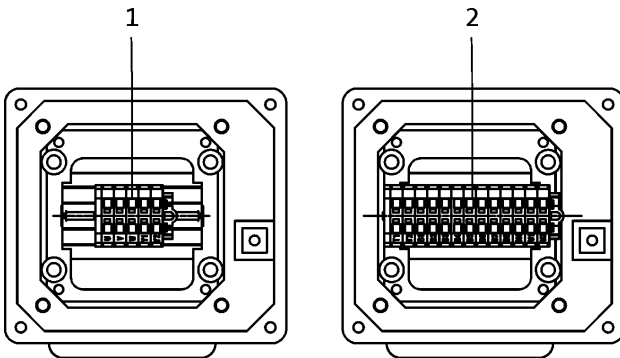

1: Power connection + brake connection + PE connection.

2: Angle/speed sensor connection + thermal sensor connection



MCA asynchronous servo motors with blower and terminal box

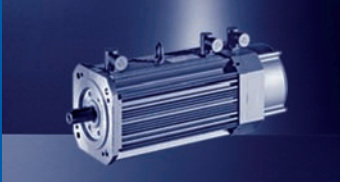

### Holding brakes

The MCA10...19 and 21 asynchronous servo motors can be equipped with integral permanent magnet holding brakes. The brake voltage available for this model is 24 V DC or 205 V DC.

Spring-applied holding brakes with voltages of 24 V DC or 230 V AC are available for MCA20, 22 and 26.

The brakes are active once the supply voltage is switched off (closed-circuit principle).

**With traversing axes**, maintaining the permissible mass inertia ratio  $J_L/J_{MB}$  ensures that the permissible maximum switching energy of the brake is not exceeded and at least 2000 emergency stop functions are possible when running at a speed of 3000 r/min.

**With lifting axes**, the load torque resulting from the force due to weight comes into play as an additional factor. In this case, the data specified for  $J_L/J_{MB}$  does not apply.

#### Caution:

**The brakes used are not safety brakes in the sense that a reduction in torque may arise as a result of disruptive factors that cannot be influenced, e.g. oil ingress.**

The ohmic voltage drop along the cable must be taken into consideration in long motor supply cables and must be compensated for by a higher voltage at the line input.

The following applies for Lenze system cables:

$$U[V] = U_B[V] + 0.08 \frac{[V]}{[A] \cdot [m]} \cdot I_{lg}[m] \cdot I_B[A]$$

If no suitable voltage (incorrect value, incorrect polarity) is applied to the brake, the brake will be applied and can be overheated and destroyed by the motor continuing to rotate. The shortest switching times of the brakes are achieved by DC switching of the voltage. A spark suppressor is required to suppress interference and to increase the service life of the relay contacts here.



*Permanent magnet holding brake*

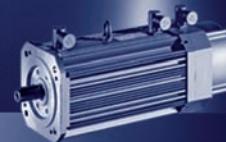

### Holding brake data

- The ratings apply only for servo motors and for geared servo motors if the servo motor is mounted by way of a mounting flange.

### B5 / B14 design servo motors GPA servo geared motors

	$U_{N,DC}^{3,4,7)}$	$U_{N,AC}^{5,7)}$	$M_N$	$M_N$	$M_{av}$	$I_N^{2)}$	$J$	$t_1^{1)}$	$t_2^{1)}$	$Q_E^{6)}$	$m$	$J_{MB}$	$J_L / J_{MB}$
	[V]	[V]	20 °C	120 °C	120 °C	[A]	[kgcm <sup>2</sup> ]	[ms]	[ms]	[J]	[kg]	[kgcm <sup>2</sup> ]	
<b>MCA10</b>	24	230	3.30	2.50	1.20	0.50	0.38	10.0	20.0	350	0.90	2.78	24.5
	205					0.060							
<b>MCA13</b>	24		12.0	11.0	5.50	0.67	1.06	20.0	29.0	400	0.80	9.36	7.70
	205					0.080							
<b>MCA14</b>	24		15.0	12.0	6.00	0.75	3.60	13.0	30.0	700	1.50	22.8	5.20
	205					0.090							
<b>MCA17</b>	24		24.0	22.0	11.0	0.75	9.50	25.0	50.0	1200	39.6	5.10	
	205					0.090							
<b>MCA19</b>	24		46.0	40.0	18.0	1.00	6.88	70.0	220	18000	13.0	177	19.6
	205					0.12							
<b>MCA20</b>	24		90.0	80.0	50.0	3.13	31.8	53.0	97.0	2800	5.00	212	1.70
<b>MCA21</b>	24					0.37							
	205		1.46	18.1	50.0	260	23000	20.5	505	8.20			
<b>MCA22</b>	24		0.18										
<b>MCA22</b>	24	150	130	80.0	3.75	36.3	175	320	39000	26.0	1405	12.7	
	205				0.44								
<b>MCA26</b>	24	300	260	160	70.4	175	360	51000	30.7				
	205			0.37									

- <sup>1)</sup> Engagement and disengagement times are valid for rated voltage ( $\pm 0\%$ ) and protective circuit for brakes with varistor for DC switching. The times may increase without a protective circuit.
- <sup>2)</sup> The currents are the maximum values when the brake is cold (value used for dimensioning the current supply). The values for a motor at operating temperature are considerably lower.
- <sup>3)</sup> With 24 V DC brake: smoothed DC voltage, ripple  $\leq 1\%$ .  
With 205 V DC brake: connection to 230 V AC through rectifier.
- <sup>4)</sup> UR not possible in the case of a brake with a 205 V supply voltage.
- <sup>5)</sup> UR not possible in the case of a brake with 230 V supply voltage.
- <sup>6)</sup> Maximum switching energy per emergency stop at  $n = 3000$  r/min for at least 2000 emergency stops.
- <sup>7)</sup> Voltage tolerance: permanent magnet brakes -10 ... 5 %  
spring-applied brakes  $\pm 10\%$



# MCA asynchronous servo motors

## Accessories

### Holding brake data, reinforced design

	U <sub>N, DC</sub> <sup>3, 4, 7)</sup>	U <sub>N, AC</sub> <sup>5, 7)</sup>	M <sub>N</sub>	M <sub>N</sub>	M <sub>av</sub>	I <sub>N</sub> <sup>2)</sup>	J	t <sub>1</sub> <sup>1)</sup>	t <sub>2</sub> <sup>1)</sup>	Q <sub>E</sub> <sup>6)</sup>	m	J <sub>MB</sub>	J <sub>L</sub> / J <sub>MB</sub>
			20 °C	120 °C	120 °C								
	[V]	[V]	[Nm]	[Nm]	[Nm]	[A]	[kgcm <sup>2</sup> ]	[ms]	[ms]	[J]	[kg]	[kgcm <sup>2</sup> ]	
MCA20	24	230	150	130	100	2.58	14.1	70.0	240	31000	15.4	189	33.0
	0.30												
MCA22	24	230	300	260	160	3.75	36.3	175	320	39000	26.0	523	14.1
	0.44					130		310					
MCA26	24	230	500	430	260	3.75	70.4	175	390	51000	30.8	1405	12.7
	0.44												

### Holding brake data

- These ratings apply only for geared servo motors with integrated servo motor (without mounting flange).

### GST, GFL, GKR, GKS, GSS geared servo motors

	U <sub>N, DC</sub> <sup>3, 4, 7)</sup>	M <sub>N</sub>	M <sub>N</sub>	M <sub>av</sub>	I <sub>N</sub> <sup>2)</sup>	J	t <sub>1</sub> <sup>1)</sup>	t <sub>2</sub> <sup>1)</sup>	Q <sub>E</sub> <sup>6)</sup>	m	J <sub>MB</sub>	J <sub>L</sub> / J <sub>MB</sub>
		20 °C	120 °C	120 °C								
	[V]	[Nm]	[Nm]	[Nm]	[A]	[kgcm <sup>2</sup> ]	[ms]	[ms]	[J]	[kg]	[kgcm <sup>2</sup> ]	
MCA10	24	6.00	5.00	2.50	0.67	1.06	20.0	29.0	400	0.80	3.46	22.4
	205				0.80							
MCA13	24	15.0	12.0	6.00	0.75	3.60	13.0	30.0	700	1.50	11.9	8.40
	205				0.090							
MCA14	24	23.0	20.0	20.0	0.92	9.50	18.0	55.0	1350	2.40	22.8	6.60
	205				0.12							
MCA17	24	23.0	20.0	20.0	0.92	9.50	18.0	55.0	1350	2.40	45.5	5.00
	205				0.12							
MCA19	24	48.0	40.0	35.0	1.46	31.8	30.0	100	2800	4.80	104	4.50
	205				0.18							
MCA21	24	88.0	80.0	35.0	1.46	31.8	53.0	97.0	2800	5.00	212	1.70
	205				0.18							

- Engagement and disengagement times are valid for rated voltage (± 0 %) and protective circuit for brakes with varistor for DC switching. The times may increase without a protective circuit.
- The currents are the maximum values when the brake is cold (value used for dimensioning the current supply). The values for a motor at operating temperature are considerably lower.
- With 24 V DC brake: smoothed DC voltage, ripple ≤ 1 %.  
With 205 V DC brake: connection to 230 V AC through rectifier.
- UR not possible in the case of a brake with a 205 V supply voltage.
- UR not possible in the case of a brake with 230 V supply voltage.
- Maximum switching energy per emergency stop at n = 3000 r/min for at least 2000 emergency stops.
- Voltage tolerance: permanent magnet brakes -10 ... 5 %  
spring-applied brakes ±10 %



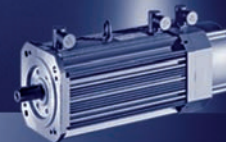

### Blower data 50 Hz

		Enclosure	Number of phases	$U_{min}$	$U_{max}$	$U_{N, AC}$	$P_N$	$I_N$
				[V]	[V]	[V]	[kW]	[A]
MCA13	F10	IP54	1	210	240	230	0.019	0.12
MCA14							0.040	0.25
MCA17							0.17	0.73
MCA19							0.060	0.26
MCA20	F10 F1F	IP23s			250		0.24	1.05
MCA21	F10	IP54			240		0.40	1.75
MCA22	F10	IP23s			250			
MCA26	F1F	IP54						

### Blower data 60 Hz

		Enclosure	Number of phases	$U_{min}$	$U_{max}$	$U_{N, AC}$	$P_N$	$I_N$
				[V]	[V]	[V]	[kW]	[A]
MCA13	F10	IP54	1	210	240	230	0.019	0.12
MCA14							0.040	0.25
MCA17							0.20	0.90
MCA19							0.060	0.26
MCA20	F10 F1F	IP23s			250		0.28	1.23
MCA21	F10	IP54			240		0.41	1.82
MCA22	F10	IP23s			250			
MCA26	F1F	IP54						

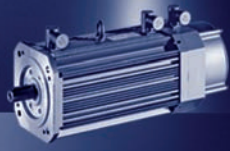

## MCA asynchronous servo motors

### Accessories

Tailored to meet the requirements of the various applications and necessary accuracies, the following feedback systems are available.

### Resolver

Stator-fed resolver with two stator windings offset by 90° and one rotor winding with transformer winding.

<b>Speed/angle sensor</b>	<sup>1)</sup>			<b>RS0</b>
<b>Resolution</b>			[°]	0.80
Angle				
<b>Accuracy</b>			[°]	-10 ... 10
<b>Absolute positioning</b>				1 revolution
<b>Max. speed</b>	$n_{max}$		[r/min]	8000
<b>Max. input voltage</b>	$U_{in,max}$		[V]	10.0
DC				
<b>Max. input frequency</b>	$f_{in,max}$		[kHz]	4.00
<b>Ratio</b>		$\pm 5\%$		0.30
Stator / rotor				
<b>Rotor impedance</b>	$Z_{ro}$		[Ω]	51 + j90
<b>Stator impedance</b>	$Z_{so}$		[Ω]	102 + j150
<b>Impedance</b>	$Z_{rs}$		[Ω]	44 + j76
<b>Min. insulation resistance</b>	$R$		[MΩ]	10.0
At DC 500 V				
<b>Number of pole pairs</b>				1
<b>Max. angle error</b>			[°]	-10 ... 10
<b>Inverter assignment</b>				E84AVTC E94A ECS EVS93

<sup>1)</sup> →  16 - Product key > speed/angle sensor

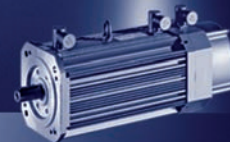

### Incremental encoder and SinCos absolute value encoder

Encoder type			TTL incremental		SinCos incremental	SinCos absolute value				
			T20	T40	S20	EQI	SRS	SRM	ECN	EQN
Speed/angle sensor	1)		IG2048-5V-T	IG4096-5V-T	IG2048-5V-S	AM32-5V-E	AS1024-8V-H	AM1024-8V-H	AS2048-5V-E	AM2048-5V-E
Encoder type					Single-turn	Multi-turn	Single-turn	Multi-turn	Single-turn	Multi-turn
Pulses			2048	4096	2048	32	1024		2048	
Output signals			TTL			1 Vss				
Interfaces						EnDat	Hiperface		EnDat	
Absolute revolutions			0			4096	1	4096	1	4096
Resolution Angle <sup>2)</sup>		[°]	2.60			0.40				
Accuracy		[°]	-2 ... 2		-0.8 ... 0.8	-5 ... 5	-0.8 ... 0.8		-0.6 ... 0.6	
Min. input voltage DC	$U_{in,min}$	[V]	4.75		4.50	4.75	7.00		4.75	
Max. input voltage DC	$U_{in,max}$	[V]	5.25		5.50	5.25	12.0		5.25	
Max. speed	$n_{max}$	[r/min]	8789		5273	12000	6000		12000	
Max. current consumption	$I_{max}$	[A]	0.15		0.10	0.17	0.080		0.15	0.25
Limit frequency	$f_{max}$	[kHz]	300		180	6.00	200			
Inverter assignment			E84AVTC E94A ECS EVS93			E94A	E84AVTC E94A ECS EVS93		E94A	

1) →  16 - Product key > speed/angle sensor

2) Dependent on inverter.

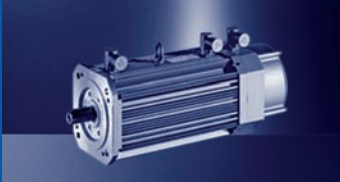

## Safety SinCos incremental encoder

- ▶ Safe encoder thanks to integrated functional safety

Encoder type			SinCos incremental
Speed/angle sensor	1)		<b>S1S</b>
			<b>IG1024-5V-V</b>
Encoder type			Single-turn
Pulses			1024
Output signals			1 Vss
Min. input voltage DC	$U_{in,min}$	[V]	4.75
Max. input voltage DC	$U_{in,max}$	[V]	5.25
Max. speed	$n_{max}$	[r/min]	8000
Max. current consumption	$I_{max}$	[A]	0.070
Limit frequency	$f_{max}$	[kHz]	200
Functional safety EN 13849-1 EN 954-1 IEC 61508			Up to Performance Level e Category 4 SIL3
Inverter assignment			E94A

1) →  16 - Product key > speed/angle sensor

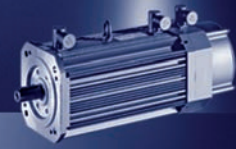

## Thermal sensor

The thermal sensors (1x KTY 83-110) used continuously monitor the motor temperature. The temperature signal is transmitted over the system cable of the feedback system to the servo controller.

This means that the temperature of the motor is determined with great accuracy in the permitted operating range and at the same time the overtemperature response configured in the controller is executed in the event of overtemperature in one of the winding phases.

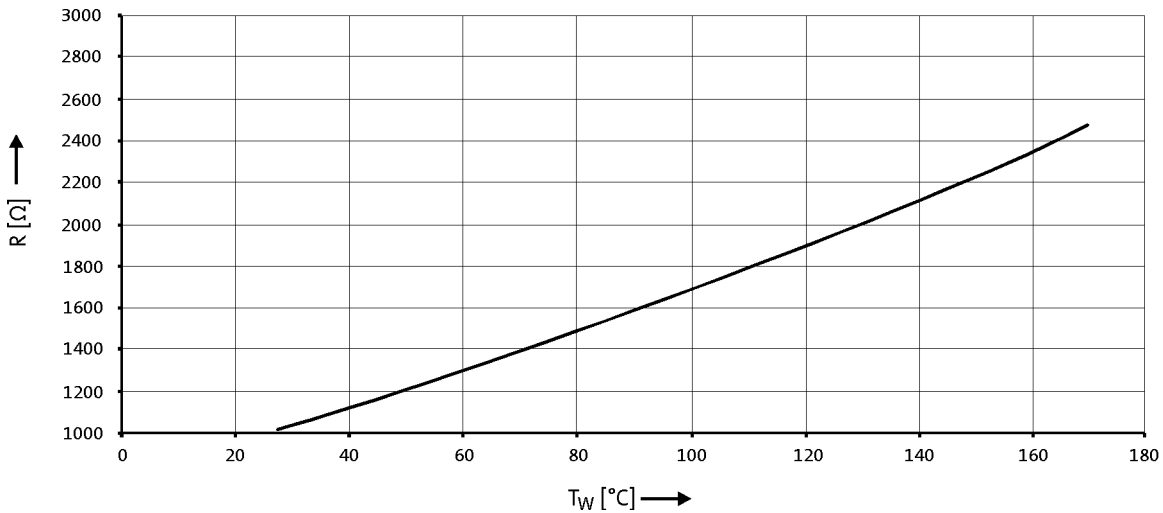

- ▶ If the detector is supplied with a measured current of 1 mA, the above relationship between the temperature and the resistance applies.

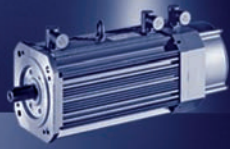

# MCA asynchronous servo motors

## Dimensions [mm]

### Motors without blower

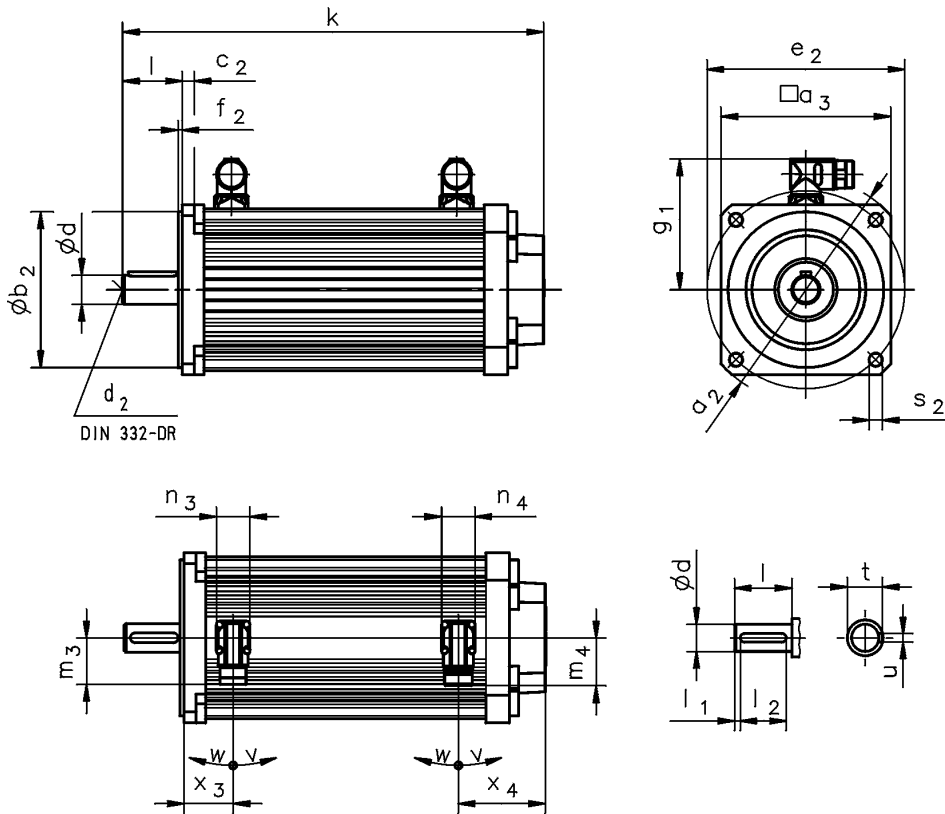

DIN 332-DR

			MCA10I40	MCA13I41	MCA14L20	MCA17N23	MCA19S23	MCA21X25
					MCA14L41	MCA17N41	MCA19S42	MCA21X42
RSO B0	k	[mm]	292	311	352	390	461	550
	x <sub>3</sub>	[mm]	37	45	41	43	56	62
	x <sub>4</sub>	[mm]	61	65	73		78	
RSO P□	k	[mm]	317	346	385	425	499	592
	x <sub>3</sub>	[mm]	59	72	68	75	91	102
	x <sub>4</sub>	[mm]	61	65	73		78	
S□□ / E□□ / T20 / B0	k	[mm]	346	365	407	444	511	599
	x <sub>3</sub>	[mm]	37	45	41	43	56	62
	x <sub>4</sub>	[mm]	115	119	128	127	123	127
S□□ / E□□ / T20 / P□	k	[mm]	371	400	440	479	549	641
	x <sub>3</sub>	[mm]	59	72	68	75	91	102
	x <sub>4</sub>	[mm]	115	119	128	127	123	127

- ▶ Speed/angle sensor: RSO / S□□ / E□□ / T20
- ▶ Brake: B0 / P□

# MCA asynchronou servo motors

## Dimensions [mm]

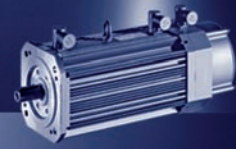

	$g_1$	$n_3$	$n_4$	$m_3$	$m_4$	$v$	$w$
	[mm]	[mm]	[mm]	[mm]	[mm]	[°]	[°]
MCA10I40	90	28	28	40	40	195	80
MCA13I41	102						
MCA14L20	109						
MCA14L41	118						
MCA17N23	118	40	71	71	71	195	80
MCA17N41	151						
MCA19S23	151						
MCA19S42	162						
MCA21X25	162						
MCA21X42							

	$d$	$d_2$	$l$	$l_1$	$l_2$	$u$	$t$
	[mm]	[mm]	[mm]	[mm]	[mm]	[mm]	[mm]
MCA10	14	M5	30	2.5	25	5.0	16
MCA13	19	M6	40	2.0	36	6.0	22
MCA14	24	M8	50	5.0	40	8.0	27
MCA17					50		
MCA19	28	M10	60		70	10.0	31
MCA21	38	M12	80		70	10.0	41

		$a_2$	$a_3$	$b_2$	$c_2$	$e_2$	$f_2$	$s_2$
		[mm]	[mm]	[mm]	[mm]	[mm]	[mm]	[mm]
MCA10	FF100	120	102	80	8	100	3.0	7
	FT85			70		85	2.5	M6
MCA13	FF130	160	130	110	9	130	3.5	9.0
	FT130			110				130
MCA14	FF165	188	142	130	10	165		11.0
	FT130			110				130
MCA17	FF165	200	165	130	12	165	11.0	
	FT130			110			130	M8
MCA19	FF215	250	192	180	11	215	4.0	13.0
	FT130			110		130	3.5	M8
MCA21	FF215	300	214	180	12	215	4.0	13.0
	FF265			230		265		
	FT130			110		130	3.5	M8

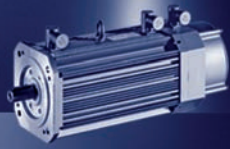

# MCA asynchronous servo motors

Dimensions [mm]

## Motors with blower, MCA13...19/21

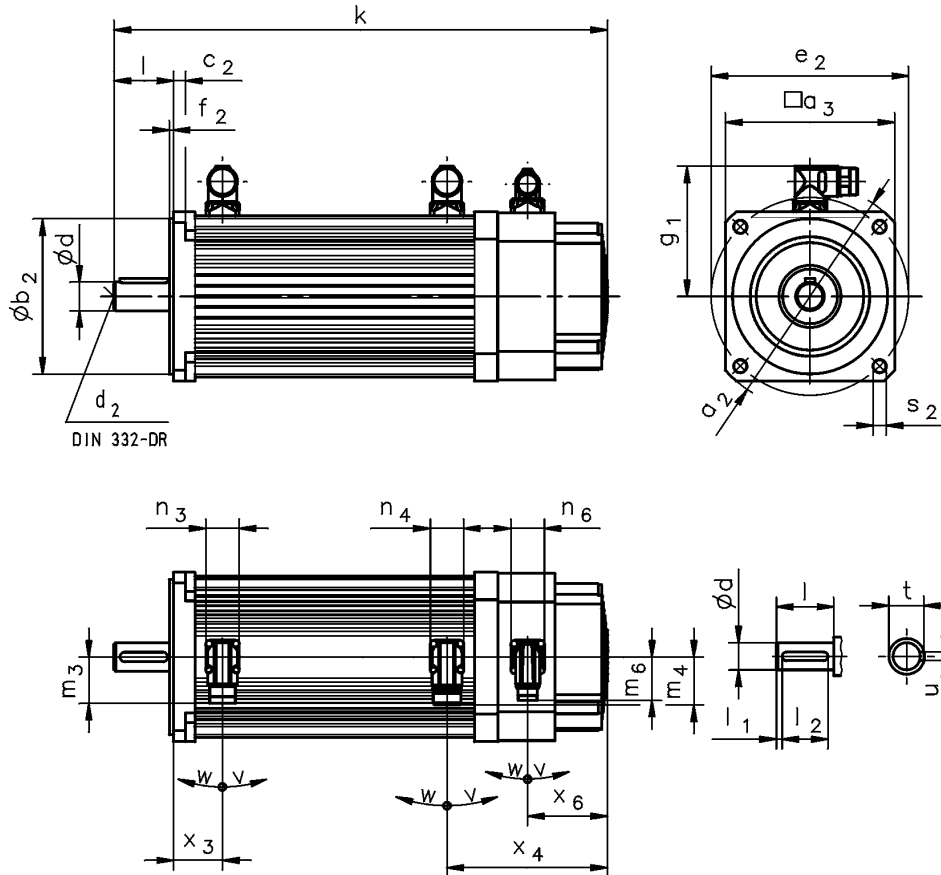

			MCA13B4	MCA14L16	MCA17N17	MCA19S17	MCA21X17
				MCA14L35	MCA17N35	MCA19S35	MCA21X35
RSO B0	k	[mm]	379	414	476	558	646
	x <sub>3</sub>	[mm]	45	41	43	56	62
	x <sub>4</sub>	[mm]	133	135	159	170	174
RSO P□	k	[mm]	414	447	511	596	688
	x <sub>3</sub>	[mm]	72	68	75	91	102
	x <sub>4</sub>	[mm]	133	135	159	170	174
S□□ / E□□ / T20 / B0	k	[mm]	433	469	530	608	695
	x <sub>3</sub>	[mm]	45	41	43	56	62
	x <sub>4</sub>	[mm]	187	190	213	220	223
S□□ / E□□ / T20 / P□	k	[mm]	468	502	565	646	737
	x <sub>3</sub>	[mm]	72	68	75	91	102
	x <sub>4</sub>	[mm]	187	190	213	220	223
	x <sub>6</sub>	[mm]	73	67	94	103	96

- ▶ Speed/angle sensor: RSO / S□□ / E□□ / T20
- ▶ Brake: B0 / P□



# MCA asynchronou servo motors

## Dimensions [mm]

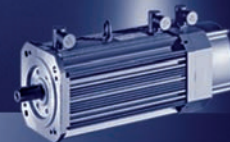

	$g_1$	$n_3$	$n_4$	$n_6$	$m_3$	$m_4$	$m_6$	$v$	$w$
	[mm]	[mm]	[mm]	[mm]	[mm]	[mm]	[mm]	[°]	[°]
MCA13B4	102	28	28	28	40	40	37	195	80
MCA14L16	109								
MCA14L35	118								
MCA17N17	118	40	28	28	71	40	37	195	80
MCA17N35	151								
MCA19S17	151								
MCA19S35	162	40	28	28	71	40	37	195	80
MCA21X17	162								
MCA21X35	162	40	28	28	71	40	37	195	80
MCA21X35	162								

	$d$	$d_2$	$l$	$l_1$	$l_2$	$u$	$t$
	k6						
	[mm]	[mm]	[mm]	[mm]	[mm]	[mm]	[mm]
MCA13	19	M6	40	2.0	36	6.0	22
MCA14	24	M8	50	5.0	40	8.0	27
MCA17					50		
MCA19	28	M10	60		70		
MCA21	38	M12	80	70	10.0	41	

		$a_2$	$a_3$	$b_2$	$c_2$	$e_2$	$f_2$	$s_2$
				j6				
		[mm]	[mm]	[mm]	[mm]	[mm]	[mm]	[mm]
MCA13	FF130	160	130	110	9	130	3.5	9.0
	FT130							M8
MCA14	FF165	188	142	130	10	165		11.0
	FT130			110				M8
MCA17	FF165	200	165	130	12	165		11.0
	FT130			110				M8
MCA19	FF215	250	192	180	11	215	4.0	13.0
	FT130			110		130	3.5	M8
MCA21	FF215	300	214	180	12	215	4.0	13.0
	FF265		250	230		265		
	FT130		214	110		11		

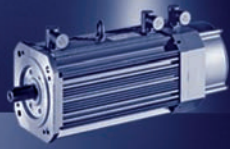

# MCA asynchronous servo motors

Dimensions [mm]

## Motors with terminal box, MCA10...19/21

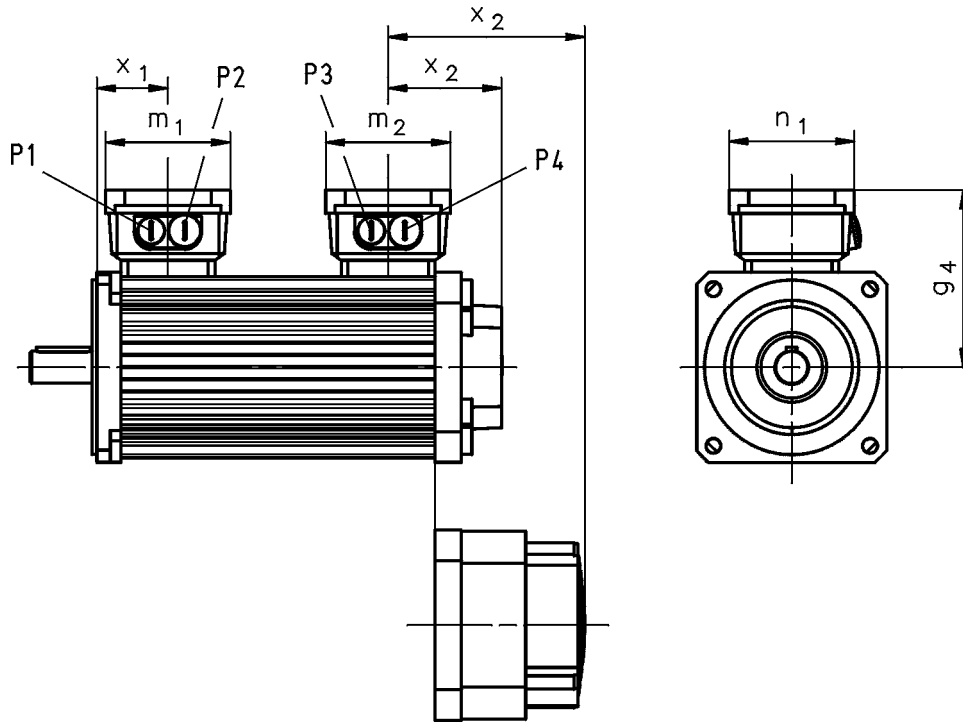

			MCA10I40	MCA13I41	MCA14L20	MCA17N23	MCA19S23	MCA21X25
					MCA14L41	MCA17N41	MCA19S42	MCA21X42
RSO B0	x <sub>2</sub>	[mm]	78	77	85		87 <sup>2)</sup> 93 <sup>1)</sup>	91 <sup>2)</sup> 97 <sup>1)</sup>
RSO P□	x <sub>2</sub>	[mm]	78	77	85		87 <sup>2)</sup> 93 <sup>1)</sup>	91 <sup>2)</sup> 97 <sup>1)</sup>
S□□ / E□□ / T20 / B0	x <sub>2</sub>	[mm]	132	131	140	139	137 <sup>2)</sup> 143 <sup>1)</sup>	141 <sup>2)</sup> 147 <sup>1)</sup>
S□□ / E□□ / T20 / P□	x <sub>2</sub>	[mm]	132	131	140	139	137 <sup>2)</sup> 143 <sup>1)</sup>	141 <sup>2)</sup> 147 <sup>1)</sup>

			MCA13I34	MCA14L16	MCA17N17	MCA19S17	MCA21X17
				MCA14L35	MCA17N35	MCA19S35	MCA21X35
RSO B0	x <sub>2</sub>	[mm]	145	147	171	190	193
RSO P□	x <sub>2</sub>	[mm]	145	147	171	190	193
S□□ / E□□ / T20 / B0	x <sub>2</sub>	[mm]	199	202	225	240	243
S□□ / E□□ / T20 / P□	x <sub>2</sub>	[mm]	199	202	225	240	243

- ▶ Speed/angle sensor: RSO / S□□ / E□□ / T20
- ▶ Brake: B0 / P□

	g <sub>4</sub>	m <sub>1</sub>	m <sub>2</sub>	n <sub>1</sub>	x <sub>1</sub>	P <sub>1</sub>	P <sub>2</sub>	P <sub>3</sub>	P <sub>4</sub>
	[mm]	[mm]	[mm]	[mm]	[mm]	[mm]	[mm]	[mm]	[mm]
MCA10	113	93	93	93	54	M16x1.5	M20x1.5	M16x1.5	M20x1.5
MCA13	125				57				
MCA14	132				53				
MCA17	140				55				
MCA19	158	120	93 <sup>1)</sup> 120 <sup>2)</sup>	93 <sup>1)</sup> 109 <sup>2)</sup>	73	M25x1.5	M32x1.5		
MCA21	169				84				

<sup>1)</sup> IP54  
<sup>2)</sup> IP65

# MCA asynchronous servo motors

Dimensions [mm]

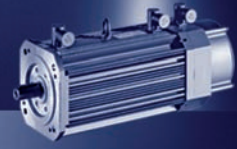

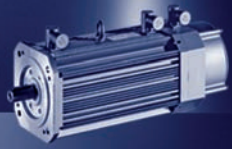

# MCA asynchrone servo motors

Dimensions [mm]

## Motors with blower, MCA20/22/26, B3

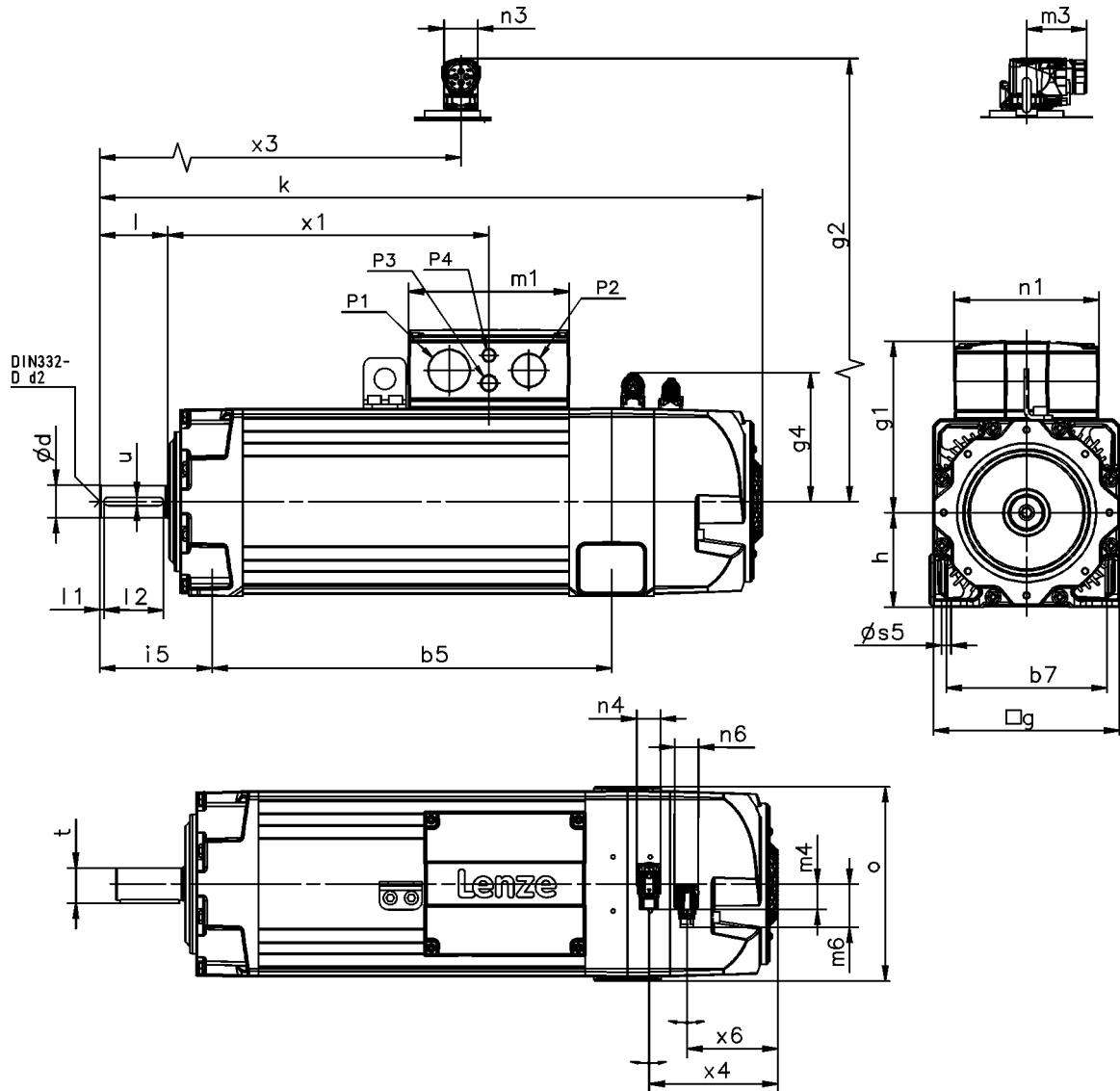

			MCA20	MCA22	MCA26
RS0 / E□□ / T□□ / S□□ / B0...F10	k	[mm]	666	783	970
RS0 / E□□ / T□□ / S□□ / B0...F1F	k	[mm]	754	865	1022
RS0 / E□□ / T□□ / S□□ / B0	x <sub>4</sub>	[mm]	146	153	194
	m <sub>4</sub>	[mm]	25.0	31.0	25.0
RS0 F1...F10	k	[mm]	753	878	1125
RS0 F1...F1F	k	[mm]	842	959	1177
RS0 F1	x <sub>4</sub>	[mm]	151	157	201
	m <sub>4</sub>	[mm]		31.0	
E□□ / T□□ / S□□ / F1...F10	k	[mm]	797	916	1163
E□□ / T□□ / S□□ / F1...F1F	k	[mm]	885	998	1215
E□□ / T□□ / S□□ / F1	x <sub>4</sub>	[mm]	146	162	200
	m <sub>4</sub>	[mm]		31.0	
RS0 / E□□ / T□□ / S□□ / F2...F10	k	[mm]	822	948	1163
RS0 / E□□ / T□□ / S□□ / F2...F1F	k	[mm]	910	1030	1215
RS0 / E□□ / T□□ / S□□ / F2	x <sub>4</sub>	[mm]	146	162	200
	m <sub>4</sub>	[mm]		31.0	

# MCA asynchronou servo motors

## Dimensions [mm]

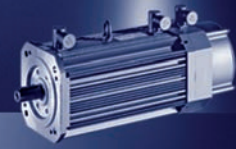

	g	g <sub>1</sub>	g <sub>2</sub>	g <sub>4</sub>	m <sub>1</sub>	m <sub>3</sub>	m <sub>6</sub>	n <sub>1</sub>	n <sub>3</sub>	n <sub>4</sub>	n <sub>6</sub>
	[mm]	[mm]	[mm]	[mm]	[mm]	[mm]	[mm]	[mm]	[mm]	[mm]	[mm]
MCA20	200	171	168	141	154	72	51	128	40	28	28
MCA22	220	203		153	190	171					
MCA26	260	256		173	238	212					

	o	P <sub>1</sub>	P <sub>2</sub>	P <sub>3</sub>	P <sub>4</sub>	x <sub>1</sub>	x <sub>3</sub>	x <sub>6</sub>
	[mm]	[mm]	[mm]	[mm]	[mm]	[mm]	[mm]	[mm]
MCA20	206	M32x1.5	M25x1.5	M20x1.5	M16x1.5	299	422	101
MCA22	230	M50x1.5	M40x1.5			380	108	
MCA26	269	M63x1.5	M50x1.5			465	152	

	d	d	d <sub>2</sub>	l	l <sub>1</sub>	l <sub>2</sub>	u	t
	k6	m6		-0.7 ... 0.3				
	[mm]	[mm]	[mm]		[mm]	[mm]	[mm]	[mm]
MCA20	38		M12	80	5.0	70	10.0	41
MCA22			M20	110		100	16.0	59
MCA26			55					

	h	b <sub>5</sub>	b <sub>7</sub>	s <sub>5</sub>	i <sub>5</sub>
	[mm]	[mm]	[mm]	[mm]	[mm]
MCA20	100	366	160	11.5	134
MCA22	112	472	190		133
MCA26	132	581	215		14.0

- ▶ Speed/angle sensor: R50 / S□□ / E□□ / T□□
- ▶ Brake: B0 / F1 / F2
- ▶ Blower: F10 / F1F

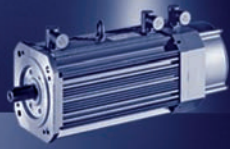

# MCA asynchrone servo motors

Dimensions [mm]

## Motors with blower, MCA20/22/26, B5

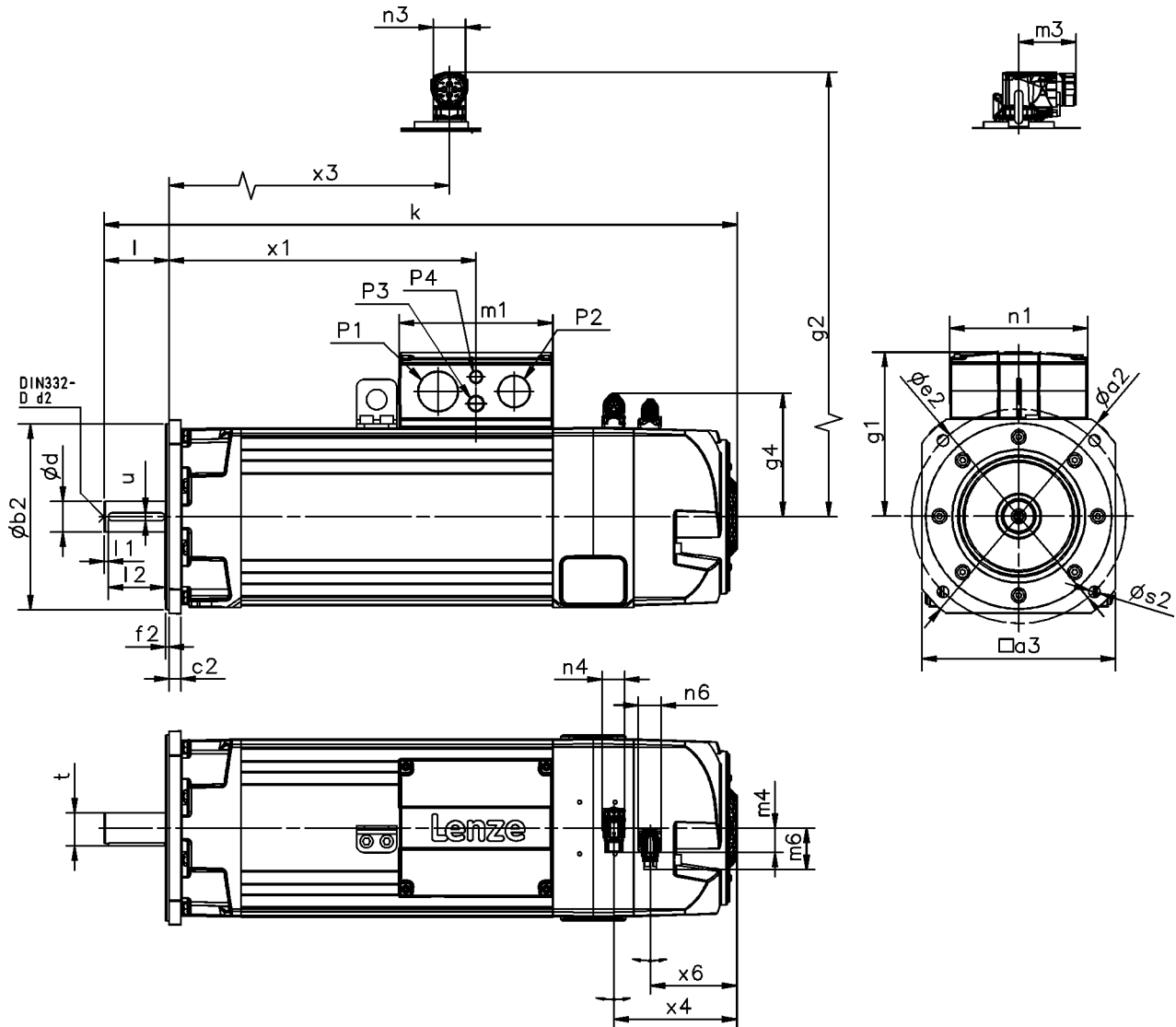

			MCA20	MCA22	MCA26
RS0 / E□□ / T□□ / S□□ / B0...F10	k	[mm]	666	783	970
RS0 / E□□ / T□□ / S□□ / B0...F1F	k	[mm]	754	865	1022
RS0 / E□□ / T□□ / S□□ / B0	x <sub>4</sub>	[mm]	146	153	194
	m <sub>4</sub>	[mm]	25.0	31.0	25.0
RS0 F1...F10	k	[mm]	753	878	1125
RS0 F1...F1F	k	[mm]	842	959	1177
RS0 F1	x <sub>4</sub>	[mm]	151	157	201
	m <sub>4</sub>	[mm]		31.0	
E□□ / T□□ / S□□ / F1...F10	k	[mm]	797	916	1163
E□□ / T□□ / S□□ / F1...F1F	k	[mm]	885	998	1215
E□□ / T□□ / S□□ / F1	x <sub>4</sub>	[mm]	146	162	200
	m <sub>4</sub>	[mm]		31.0	
RS0 / E□□ / T□□ / S□□ / F2...F10	k	[mm]	822	948	1163
RS0 / E□□ / T□□ / S□□ / F2...F1F	k	[mm]	910	1030	1215
RS0 / E□□ / T□□ / S□□ / F2	x <sub>4</sub>	[mm]	146	162	200
	m <sub>4</sub>	[mm]		31.0	

# MCA asynchronou servo motors

## Dimensions [mm]

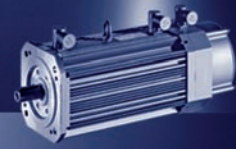

	g	g <sub>1</sub>	g <sub>2</sub>	g <sub>4</sub>	m <sub>1</sub>	m <sub>3</sub>	m <sub>6</sub>	n <sub>1</sub>	n <sub>3</sub>	n <sub>4</sub>	n <sub>6</sub>
	[mm]	[mm]	[mm]	[mm]	[mm]	[mm]	[mm]	[mm]	[mm]	[mm]	[mm]
MCA20	200	171	168	141	154	72	51	128	40	28	28
MCA22	220	203		153	190	171					
MCA26	260	256		173	238	212					

	o	P <sub>1</sub>	P <sub>2</sub>	P <sub>3</sub>	P <sub>4</sub>	x <sub>1</sub>	x <sub>3</sub>	x <sub>6</sub>
	[mm]	[mm]	[mm]	[mm]	[mm]	[mm]	[mm]	[mm]
MCA20	206	M32x1.5	M25x1.5	M20x1.5	M16x1.5	299	422	101
MCA22	230	M50x1.5	M40x1.5			380	108	
MCA26	269	M63x1.5	M50x1.5			465	152	

	d	d	d <sub>2</sub>	l	l <sub>1</sub>	l <sub>2</sub>	u	t
	k6	m6		-0.7 ... 0.3				
	[mm]	[mm]	[mm]		[mm]	[mm]	[mm]	[mm]
MCA20	38		M12	80	5.0	70	10.0	41
MCA22			M20	110		100	16.0	59
MCA26			55					

			MCA20		MCA22	MCA26	
			FF215		FF265		FF350
a <sub>2</sub>		[mm]	250		300		400
a <sub>3</sub>		[mm]	196		240		320
b <sub>2</sub>	j6	[mm]	180		230		
b <sub>2</sub>	h6	[mm]					300
c <sub>2</sub>		[mm]			15		
e <sub>2</sub>		[mm]	215		265		350
f <sub>2</sub>		[mm]			4.0		5.0
s <sub>2</sub>		[mm]			14		18

- ▶ Speed/angle sensor: R50 / S□□ / E□□ / T□□
- ▶ Brake: B0 / F1 / F2
- ▶ Blower: F10 / F1F

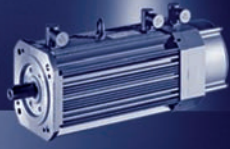

## MCA asynchronous servo motors

Dimensions [mm]



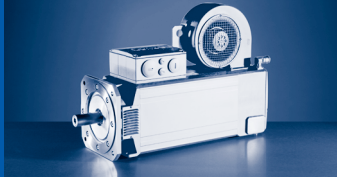

## Mains connection 3x 400 V

	$n_N$	$M_0$	$M_{max}$	$M_N$	$P_N$	$I_0$	$I_N$	$U_{N, AC}$	$f_N$	$J^{1)}$	$\eta_{100\%}$
	[r/min]	[Nm]	[Nm]	[Nm]	[kW]	[A]	[A]	[V]	[Hz]	[kgcm <sup>2</sup> ]	[%]
MQA20L14...2F□□	1420	76.0	250	71.3	10.6	27.0	26.5	360	50	171	80
MQA20L29...2F□□	2930	76.0	250	66.2	20.3	54.0	46.9	360	100	171	90
MQA22P08...2F□□	760	156	500	145	11.5	29.5	27.6	360	28	487	77
MQA22P14...2F□□	1425	156	500	135	20.1	51.0	45.6	360	50	487	86
MQA22P17...2F□□	1670	156	500	130	22.7	59.0	50.3	360	58	487	88
MQA22P29...2F□□	2935	156	500	125	38.4	102	86.0	360	100	487	90
MQA26T05...2F□□	550	325	1100	296	17.0	48.5	44.5	360	20	1335	81
MQA26T10...2F□□	1030	325	1100	288	31.1	85.5	76.2	360	36	1335	87
MQA26T12...2F□□	1200	325	1100	282	35.4	109	88.8	360	42	1335	82
MQA26T22...2F□□	2235	325	1100	257	60.2	171	138	340	76	1335	92

	$R_1$	$R_{UV\ 20^\circ C}$	$R_{UV\ 150^\circ C}$	$R_2$	$L_{1\sigma}$	$L$	$L_{2\sigma}$	$n_{max}^{2)}$	$m^{1)}$
	[Ω]	[Ω]	[Ω]	[Ω]	[mH]	[mH]	[mH]	[r/min]	[kg]
MQA20L14...2F□□	0.37	0.73	1.10	0.57	1.98	52.5	2.10	6500	63.0
MQA20L29...2F□□	0.091	0.18	0.28	0.14	0.49	13.0	0.52		
MQA22P08...2F□□	0.54	1.07	1.62	0.75	5.05	83.0	4.76		102
MQA22P14...2F□□		0.36	0.54		3.57	86.9	4.81		
MQA22P17...2F□□	0.13	0.27	0.40	0.19	0.90	21.7	1.21		
MQA22P29...2F□□		0.080	0.12		0.89	21.5	1.20		
MQA26T05...2F□□	0.29	0.59	0.89	0.39	2.57	54.0	4.78		193
MQA26T10...2F□□		0.20	0.30		2.33	57.4	4.91		
MQA26T12...2F□□	0.080	0.15	0.23	0.098	0.63	12.6	1.18		
MQA26T22...2F□□		0.050	0.075		0.73	17.8	1.34		

<sup>1)</sup> Without brake.

<sup>2)</sup> Mechanically permissible maximum speed.

The data in the  $R_1$ ,  $L_{1\sigma}$ ,  $L_h$ ,  $R_2'$  and  $L_{2\sigma}'$  columns is based on a single-phase equivalent circuit diagram at 20°C.

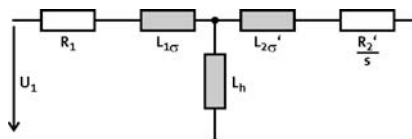

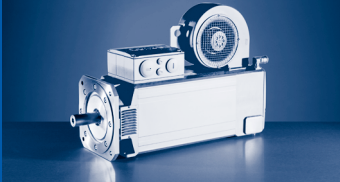

# MQA asynchronous servo motors

## Rated data

### Permissible radial and axial forces

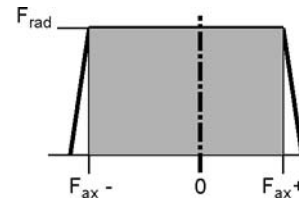
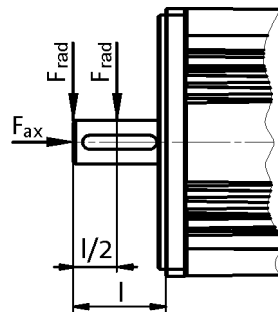

#### Application of force at l/2

	Bearing service life $L_{10}$														
	5000 h			10000 h			20000 h			30000 h			50000 h		
	$F_{rad}$	$F_{ax,-}$	$F_{ax,+}$	$F_{rad}$	$F_{ax,-}$	$F_{ax,+}$	$F_{rad}$	$F_{ax,-}$	$F_{ax,+}$	$F_{rad}$	$F_{ax,-}$	$F_{ax,+}$	$F_{rad}$	$F_{ax,-}$	$F_{ax,+}$
	[N]	[N]	[N]	[N]	[N]	[N]	[N]	[N]	[N]	[N]	[N]	[N]	[N]	[N]	[N]
<b>MQA20</b>	3400	-1330	690	2500	-1020	380	1950	-780	140	1700	-690	40			
<b>MQA22</b>	3600	-2370	1700	2800	-1740	1090	2200	-1280	640	1900	-1080	440	1600	-880	240
<b>MQA26</b>	6950	-2500	1580	5400	-1800	880	4300	-1300	380	3700	-1090	160			

#### Application of force at l

	Bearing service life $L_{10}$														
	5000 h			10000 h			20000 h			30000 h			50000 h		
	$F_{rad}$	$F_{ax,-}$	$F_{ax,+}$	$F_{rad}$	$F_{ax,-}$	$F_{ax,+}$	$F_{rad}$	$F_{ax,-}$	$F_{ax,+}$	$F_{rad}$	$F_{ax,-}$	$F_{ax,+}$	$F_{rad}$	$F_{ax,-}$	$F_{ax,+}$
	[N]	[N]	[N]	[N]	[N]	[N]	[N]	[N]	[N]	[N]	[N]	[N]	[N]	[N]	[N]
<b>MQA20</b>	3150	-1170	530	2300	-920	280	1800	-710	70	1400	-650	0			
<b>MQA22</b>	3500	-2240	1600	2600	-1640	1100	2050	-1200	560	1800	-1020	380	1450	-850	200
<b>MQA26</b>	6400	-2080	1150	5000	-1600	680	4000	-1160	230	3400	-1090	50			

- ▶ The values for the bearing service life  $L_{10}$  refer to an average speed of 3000 r/min. Depending on the ambient temperatures, the service life of the bearings is also reduced by the grease lifetime.

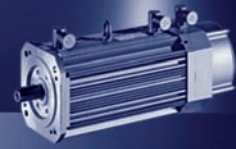

## Permissible radial and axial forces

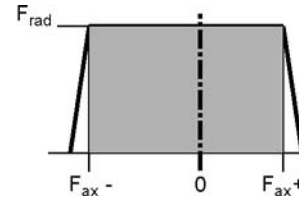
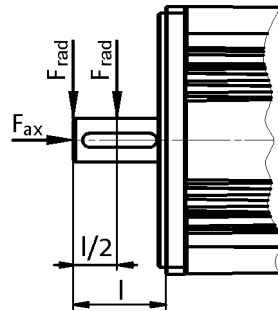

## Reinforced bearings

### Application of force at l/2

	Bearing service life $L_{10}$														
	5000 h			10000 h			20000 h			30000 h			50000 h		
	$F_{rad}$	$F_{ax,-}$	$F_{ax,+}$	$F_{rad}$	$F_{ax,-}$	$F_{ax,+}$	$F_{rad}$	$F_{ax,-}$	$F_{ax,+}$	$F_{rad}$	$F_{ax,-}$	$F_{ax,+}$	$F_{rad}$	$F_{ax,-}$	$F_{ax,+}$
	[N]	[N]	[N]	[N]	[N]	[N]	[N]	[N]	[N]	[N]	[N]	[N]	[N]	[N]	[N]
<b>MQA20</b>	7100	-970	330	5100	-800	160	3900	-640	0						
<b>MQA22</b>	8500	-1850	1200	7000	-1400	760	5600	-1030	390	4350	-930	290	3200	-800	160
<b>MQA26</b>	10500	-2180	1250	8370	-1530	600	6670	-1130	200	5840	-960	30			

### Application of force at l

	Bearing service life $L_{10}$														
	5000 h			10000 h			20000 h			30000 h			50000 h		
	$F_{rad}$	$F_{ax,-}$	$F_{ax,+}$	$F_{rad}$	$F_{ax,-}$	$F_{ax,+}$	$F_{rad}$	$F_{ax,-}$	$F_{ax,+}$	$F_{rad}$	$F_{ax,-}$	$F_{ax,+}$	$F_{rad}$	$F_{ax,-}$	$F_{ax,+}$
	[N]	[N]	[N]	[N]	[N]	[N]	[N]	[N]	[N]	[N]	[N]	[N]	[N]	[N]	[N]
<b>MQA20</b>	6350	-720	80	4100	-680	40	2800		0						
<b>MQA22</b>	7000	-1750	1100	5500	-1300	660	4700	-920	280	3900	-820	180	3000	-700	60
<b>MQA26</b>	9600	-2200	1280	7700	-1280	360	6000	-960	30						

- ▶ The values for the bearing service life  $L_{10}$  refer to an average speed of 3000 r/min. Depending on the ambient temperatures, the service life of the bearings is also reduced by the grease lifetime.

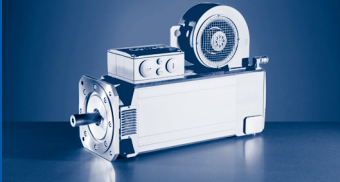

## MQA asynchronous servo motors

### 9400 Servo Drives selection tables

#### Mains connection 3 x 400 V and switching frequency 8 kHz

					E94A□□	E0174	E0244	E0324	E0474	E0594	E0864	E1044	E1454	E1724
					$I_N$	16.5	23.5	32.0	41.0	41.0	73.0	78.0	102.0	120.0
					$I_{0,max}$	49.5	58.8	76.8	94.0	118.0	172.0	208.0	261.0	310.0
MQA	$M_N$	$n_N$	$I_N$	$P_N$	$I_{max}$	49.5	58.8	76.8	94.0	118.0	172.0	208.0	261.0	310.0
20L14- ...2F□□	71.3	1420	26.5	10.60	$M_0$	32.5	66.0							
					$M_N$	32.5	66.0							
					$M_{0,max}$	154.2	190.0							
					$M_{max}$	154.2	190.0							
					$n_{eto}$	-	-							
20L29- ...2F□□	66.2	2930	46.9	20.30	$M_0$			28.0	51.6	51.6				
					$M_N$			28.0	51.6	51.6				
					$M_{0,max}$			116.0	148.2	192.8				
					$M_{max}$			116.0	148.2	192.8				
					$n_{eto}$			-	-	-				
22P08- ...2F□□	145.0	760	27.6	11.50	$M_0$		116.0	156.0						
					$M_N$		116.0	145.0						
					$M_{0,max}$		313.0	402.0						
					$M_{max}$		313.0	402.0						
					$n_{eto}$		-	-						
22P14- ...2F□□	135.0	1425	45.6	20.10	$M_0$					118.0				
					$M_N$					118.0				
					$M_{0,max}$					372.0				
					$M_{max}$					372.0				
					$n_{eto}$					-				
22P17- ...2F□□	130.0	1670	50.3	22.70	$M_0$					99.0	156.0			
					$M_N$					99.0	130.0			
					$M_{0,max}$					325.0	463.0			
					$M_{max}$					325.0	463.0			
					$n_{eto}$					-	-			
22P29- ...2F□□	125.0	2935	86.0	38.40	$M_0$							109.0	156.0	156.0
					$M_N$							109.0	125.0	125.0
					$M_{0,max}$							335.0	416.0	486.0
					$M_{max}$							335.0	416.0	486.0
					$n_{eto}$							-	-	-

- ▶  $I...$  [A],  $M...$  [Nm],  $n...$  [r/min],  $P...$  [kW]
- ▶ If the motors are operated at a lower switching frequency, please contact your Lenze sales office!
- ▶ When operating at 4 kHz, the motor generates just 95 % of its rated torque with increased noise emissions.

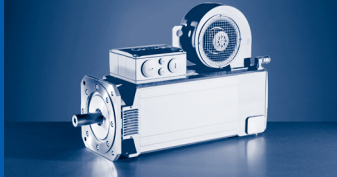

### Mains connection 3 x 400 V and switching frequency 8 kHz

					E94A□□	E0474	E0594	E0864	E1044	E1454	E1724	E2024	E2454	E2924	E3664
					$I_N$	41.0	41.0	73.0	78.0	102.0	120.0	131.0	160.0	191.0	240.0
					$I_{0,max}$	94.0	118.0	172.0	208.0	261.0	310.0	364.0	441.0	526.0	659.0
MQA	$M_N$	$n_N$	$I_N$	$P_N$	$I_{max}$	94.0	118.0	172.0	208.0	261.0	310.0	364.0	441.0	526.0	659.0
26T05- ...2F□□	296.0	550	44.5	17.00	$M_0$	268.0	268.0	325.0							
					$M_N$	268.0	268.0	296.0							
					$M_{0,max}$	665.0	826.0	1100.0							
					$M_{max}$	665.0	826.0	1100.0							
					$n_{eto}$	-	-	-							
26T10- ...2F□□	288.0	1030	76.2	31.10	$M_0$			270.0	298.0	325.0					
					$M_N$			270.0	288.0	288.0					
					$M_{0,max}$			713.0	855.0	1044.0					
					$M_{max}$			713.0	855.0	1044.0					
					$n_{eto}$			-	-	-					
26T12- ...2F□□	282.0	1200	88.8	35.40	$M_0$				219.0	291.0	325.0	325.0			
					$M_N$				219.0	282.0	282.0	282.0			
					$M_{0,max}$				609.0	739.0	840.0	950.0			
					$M_{max}$				609.0	739.0	840.0	950.0			
					$n_{eto}$				-	-	-	-			
26T22- ...2F□□	257.0	2235	138.1	60.10	$M_0$							242.0	290.0	325.0	325.0
					$M_N$							242.0	257.0	257.0	257.0
					$M_{0,max}$							711.0	843.0	1001.0	1100.0
					$M_{max}$							711.0	843.0	1001.0	1100.0
					$n_{eto}$							-	-	-	-

- ▶  $I...$  [A],  $M...$  [Nm],  $n...$  [r/min],  $P...$  [kW]
- ▶ If the motors are operated at a lower switching frequency, please contact your Lenze sales office!
- ▶ When operating at 4 kHz, the motor generates just 95 % of its rated torque with increased noise emissions.

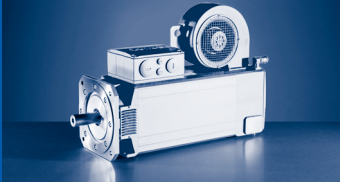

# MQA asynchronous servo motors

## Selection tables for Inverter Drives 8400 TopLine

### Mains connection 3 x 400 V and switching frequency 8 kHz

					E84AVTC	□1134	□1534	□1834	□2234	□3034	□3734	□4534	
					$I_N$	23.5	32.0	39.0	47.0	61.0	76.0	89.0	
					$I_{0,max}$	32.9	43.2	60.0	70.5	91.5	114.0	133.5	
MQA	$M_N$	$n_N$	$I_N$	$P_N$	$I_{max}$	47.0	64.0	78.0	94.0	122.0	152.0	178.0	
20L14-...2F□□	71.3	1420	26.5	10.60	$M_0$	-	76.0	76.0	76.0	76.0			
					$M_N$	-	71.3	71.3	71.3	71.3			
					$M_{0,max}$	146.0	202.0	249.2	286.3	339.1			
					$M_{max}$	146.0	202.2	249.2	286.3	339.1			
					$\eta_{eto}$	-	-	-	-	-			
20L29-...2F□□	66.2	2930	46.9	20.30	$M_0$			-	76.0	76.0	76.0	76.0	
					$M_N$			-	66.2	66.2	66.2	66.2	66.2
					$M_{0,max}$			121.8	140.9	183.7	224.5	275.9	
					$M_{max}$			121.8	140.9	183.9	225.5	276.6	
					$\eta_{eto}$			-	-	-	-	-	
22P08-...2F□□	145.0	760	27.6	11.50	$M_0$	-	156.0	156.0	156.0	156.0			
					$M_N$	-	144.5	144.5	144.5	144.5			
					$M_{0,max}$	222.8	310.5	377.0	372.9	374.6			
					$M_{max}$	223.0	310.5	377.0	372.9	374.6			
					$\eta_{eto}$	-	-	-	-	-			
22P14-...2F□□	135.0	1425	45.6	20.10	$M_0$		-	-	156.0	156.0	156.0	156.0	
					$M_N$		-	-	134.7	134.7	134.7	134.7	
					$M_{0,max}$		185.1	230.6	267.1	343.7	418.3	512.3	
					$M_{max}$		185.1	230.6	267.1	344.4	420.0	514.4	
					$\eta_{eto}$		-	-	-	-	-	-	
22P17-...2F□□	130.0	1670	50.3	22.70	$M_0$			-	-	156.0	156.0	156.0	
					$M_N$			-	-	129.8	129.8	129.8	
					$M_{0,max}$			198.6	230.2	300.0	365.3	447.0	
					$M_{max}$			198.6	230.4	300.0	367.5	449.9	
					$\eta_{eto}$			-	-	-	-	-	
22P29-...2F□□	125.0	2935	86.0	38.40	$M_0$					-	-	156.0	
					$M_N$					-	-	124.9	
					$M_{0,max}$					176.1	218.9	263.2	
					$M_{max}$					176.4	219.6	264.1	
					$\eta_{eto}$					-	-	-	
26T05-...2F□□	296.0	550	44.5	17.00	$M_0$		-	-	325.0	325.0	325.0	325.0	
					$M_N$		-	-	295.2	295.2	295.2	295.2	
					$M_{0,max}$		390.4	489.6	567.1	744.4	902.3	1080.2	
					$M_{max}$		390.4	490.2	568.0	744.8	904.7	1080.2	
					$\eta_{eto}$		-	-	-	-	-	-	
26T10-...2F□□	288.0	1030	76.2	31.10	$M_0$					-	-	325.0	
					$M_N$					-	-	288.3	
					$M_{0,max}$					429.7	532.5	638.2	
					$M_{max}$					431.4	534.1	641.5	
					$\eta_{eto}$					-	-	-	
26T12-...2F□□	282.0	1200	88.8	35.40	$M_0$						-	325.0	
					$M_N$						-	281.7	
					$M_{0,max}$						458.2	550.4	
					$M_{max}$						460.6	552.9	
					$\eta_{eto}$						-	-	

- ▶  $I...$  [A],  $M...$  [Nm],  $n...$  [r/min],  $P...$  [kW]
- ▶ If the motors are operated at a lower switching frequency, please contact your Lenze sales office!

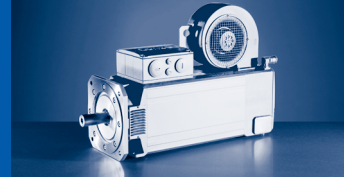

### Mains connection 3 x 400 V and switching frequency 8 kHz

					EVS	9326-E□	9327-E□	9328-E□	9329-E□	9330-E□	9331-E□	9332-E□
					$I_N$	23.5	32.0	47.0	59.0	89.0	110.0	145.0
					$I_{0,max}$	23.5	32.0	47.0	52.0	80.0	110.0	126.0
MQA	$M_N$	$n_N$	$I_N$	$P_N$	$I_{max}$	35.3	48.0	70.5	88.5	133.5	165.0	217.5
20L14- ...2F□□	71.3	1420	26.5	10.60	$M_0$	61.0	76.0	76.0				
					$M_N$	61.0	71.3	71.3				
					$M_{0,max}$	61.0	112.0	187.0				
					$M_{max}$	109.3	156.7	232.1				
					$\eta_{eto}$	-	-	-				
20L29- ...2F□□	66.2	2930	46.9	20.30	$M_0$		28.0	66.3	76.0	76.0		
					$M_N$		28.0	66.2	66.2	66.2		
					$M_{0,max}$		28.0	66.3	95.0	169.0		
					$M_{max}$		68.5	112.5	146.4	226.7		
					$\eta_{eto}$		-	-	-	-		
22P08- ...2F□□	145.0	760	27.6	11.50	$M_0$		156.0	156.0	156.0			
					$M_N$		145.0	145.0	145.0			
					$M_{0,max}$		177.0	280.0	293.0			
					$M_{max}$		247.0	338.8	345.8			
					$\eta_{eto}$		-	-	-			
22P14- ...2F□□	135.0	1425	45.6	20.10	$M_0$			146.0	156.0	156.0		
					$M_N$			135.0	135.0	135.0		
					$M_{0,max}$			146.0	186.0	188.0		
					$M_{max}$			230.1	292.9	341.8		
					$\eta_{eto}$			-	-	-		
22P17- ...2F□□	130.0	1670	50.3	22.70	$M_0$			124.0	156.0	156.0	156.0	
					$M_N$			124.0	130.0	130.0	130.0	
					$M_{0,max}$			124.0	140.0	240.0	335.0	
					$M_{max}$			180.5	227.7	342.1	378.3	
					$\eta_{eto}$			-	-	-	-	
22P29- ...2F□□	125.0	2935	86.0	38.40	$M_0$					135.5	156.0	156.0
					$M_N$					125.0	125.0	125.0
					$M_{0,max}$					137.0	195.0	250.0
					$M_{max}$					215.6	273.1	355.1
					$\eta_{eto}$					-	-	-
26T05- ...2F□□	296.0	550	44.5	17.00	$M_0$			303.0	325.0	325.0		
					$M_N$			296.0	296.0	296.0		
					$M_{0,max}$			303.0	333.0	615.0		
					$M_{max}$			482.0	612.0	751.0		
					$\eta_{eto}$			-	-	-		
26T10- ...2F□□	288.0	1030	76.2	31.10	$M_0$					319.0	325.0	
					$M_N$					288.0	288.0	
					$M_{0,max}$					300.0	440.0	
					$M_{max}$					552.0	671.0	
					$\eta_{eto}$					-	-	
26T12- ...2F□□	282.0	1200	88.8	35.40	$M_0$					284.0	325.0	325.0
					$M_N$					282.0	282.0	282.0
					$M_{0,max}$					258.0	327.0	397.0
					$M_{max}$					424.0	512.0	663.0
					$\eta_{eto}$					-	-	-
26T22- ...2F□□	257.0	2235	138.1	60.10	$M_0$						177.0	222.0
					$M_N$						177.0	257.0
					$M_{0,max}$						203.0	220.0
					$M_{max}$						315.0	432.0
					$\eta_{eto}$						-	-

- ▶  $I...$  [A],  $M...$  [Nm],  $n...$  [r/min],  $P...$  [kW]
- ▶ If the motors are operated at a lower switching frequency, please contact your Lenze sales office!

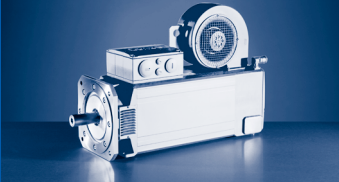

# MQA asynchronous servo motors

## Torque characteristics

Mains connection 3x 400 V

MQA20L14...2F□□

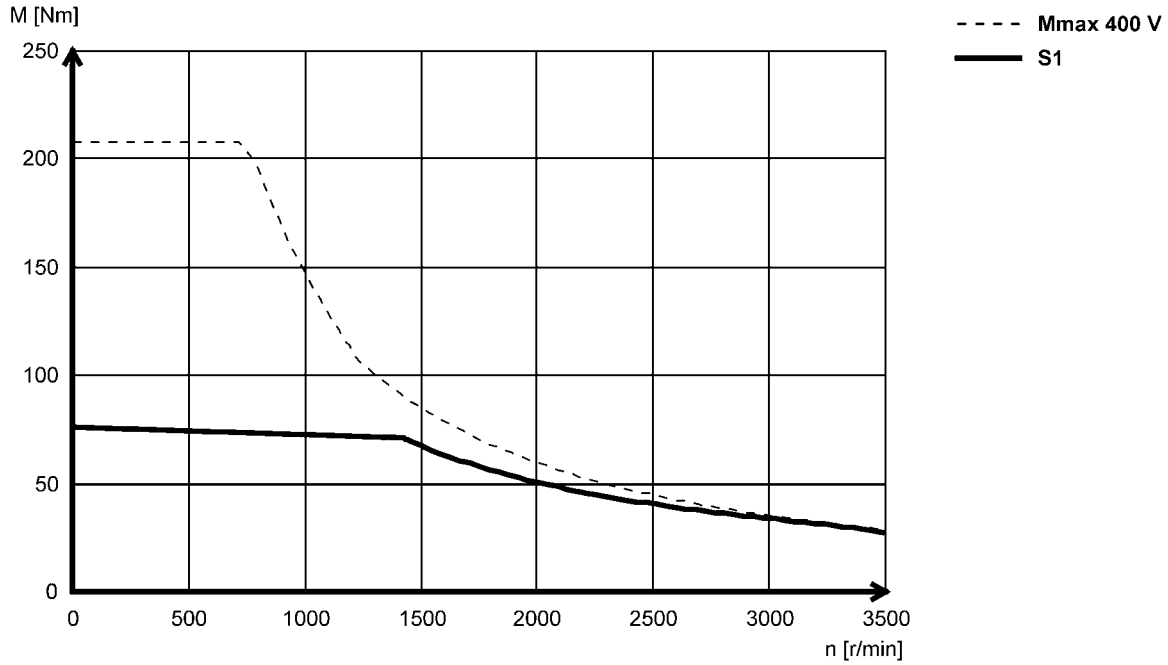

MQA20L29...2F□□

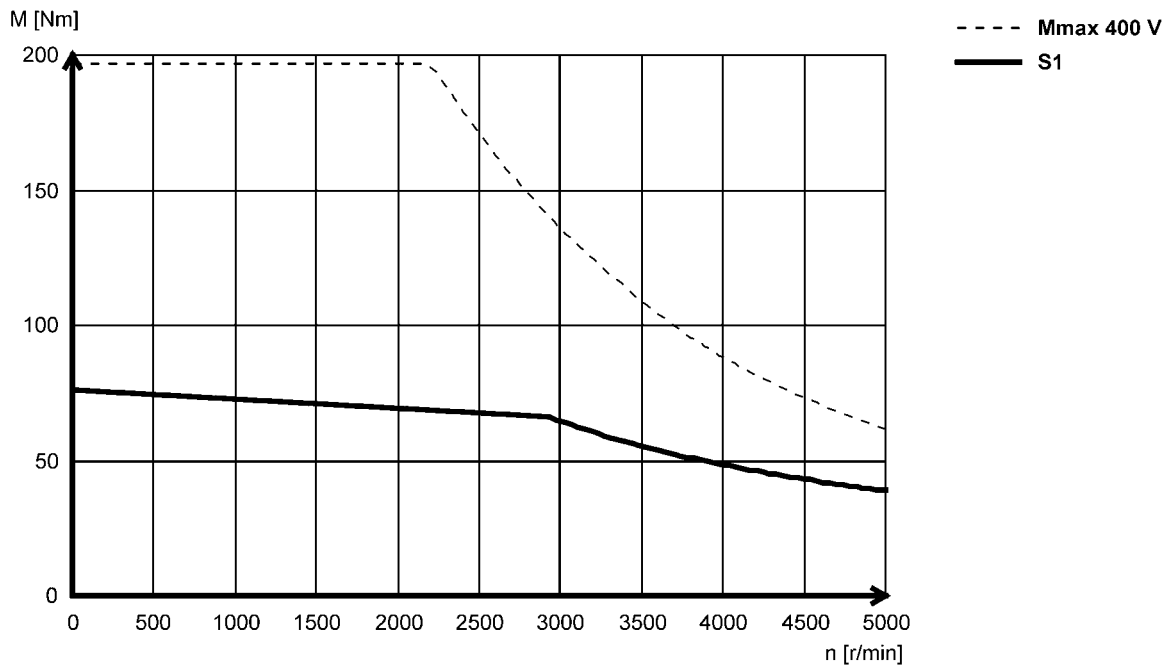

► Other torque characteristics with Lenze inverters can be found at [www.lenze.de/dsc](http://www.lenze.de/dsc).



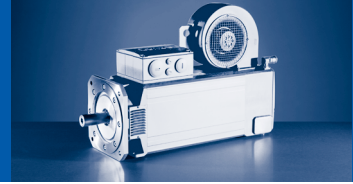

Mains connection 3x 400 V

MQA22P08...2F□□

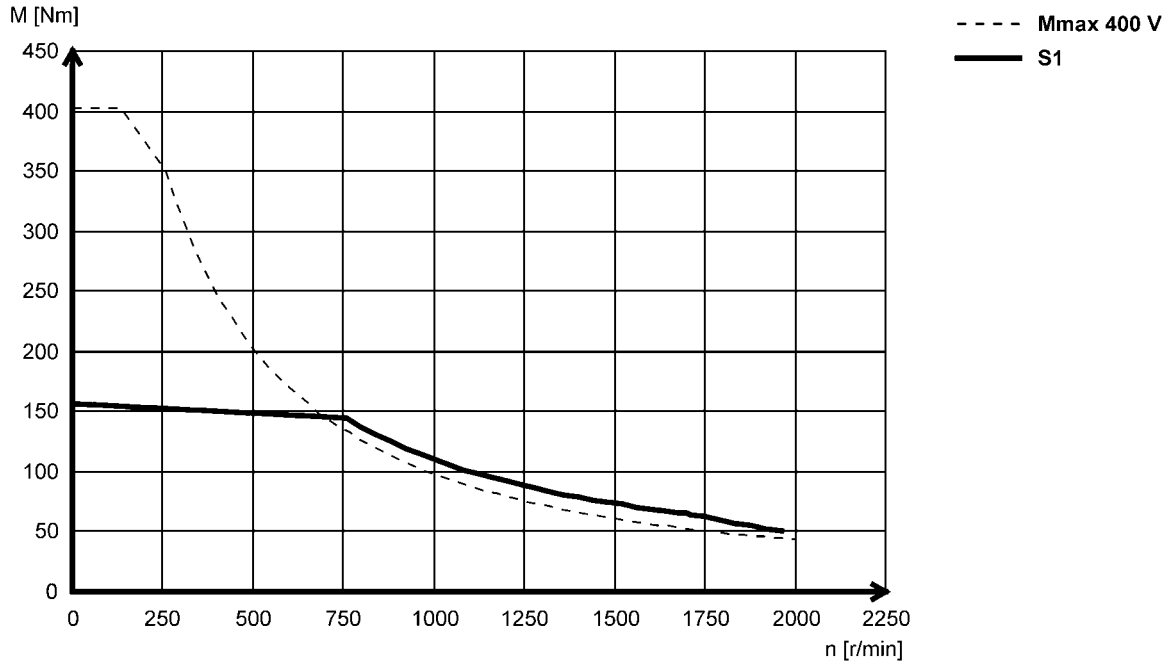

MQA22P14...2F□□

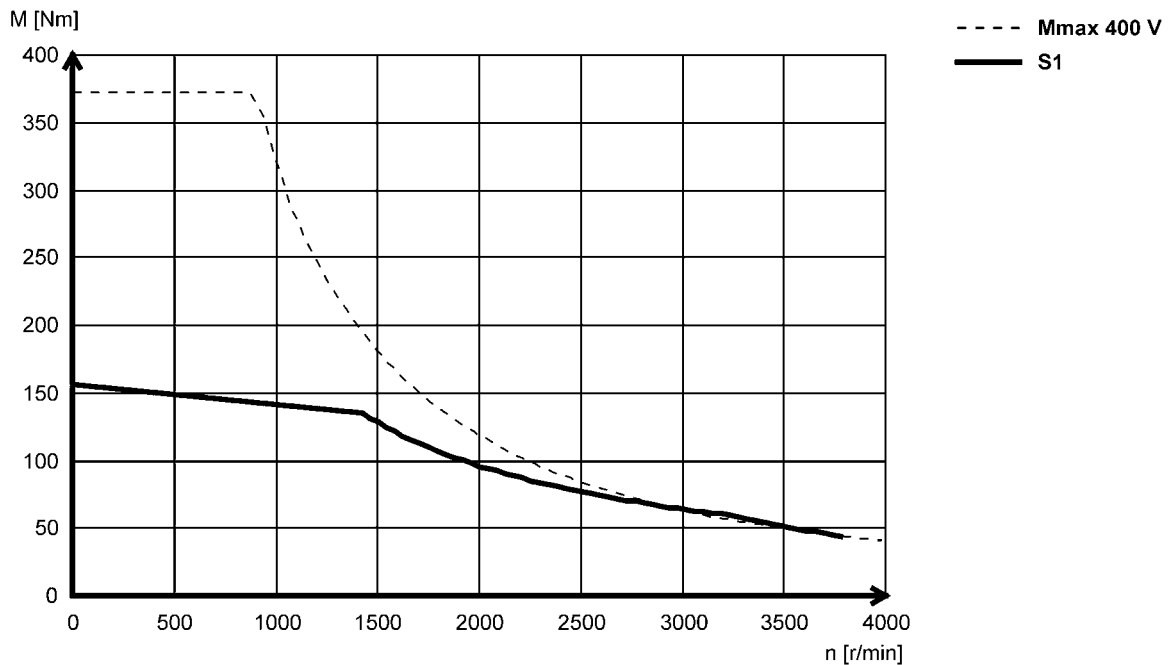

► Other torque characteristics with Lenze inverters can be found at [www.lenze.de/dsc](http://www.lenze.de/dsc).

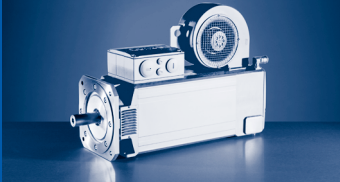

# MQA asynchronous servo motors

## Torque characteristics

Mains connection 3x 400 V

MQA22P17...2F□□

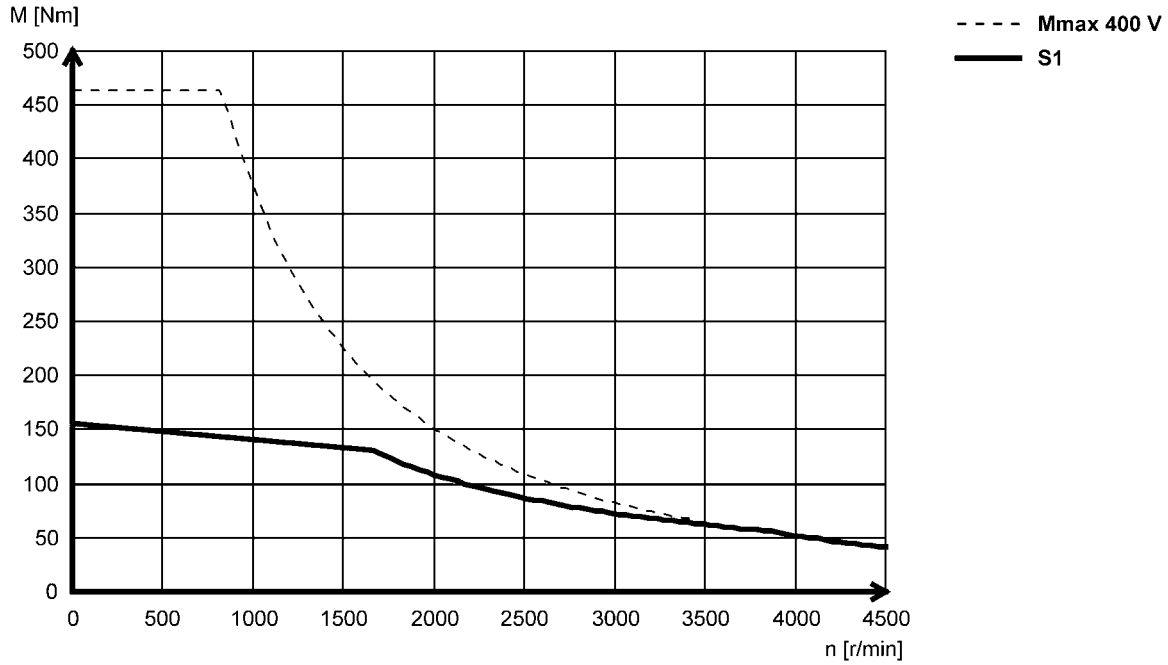

6

MQA22P29...2F□□

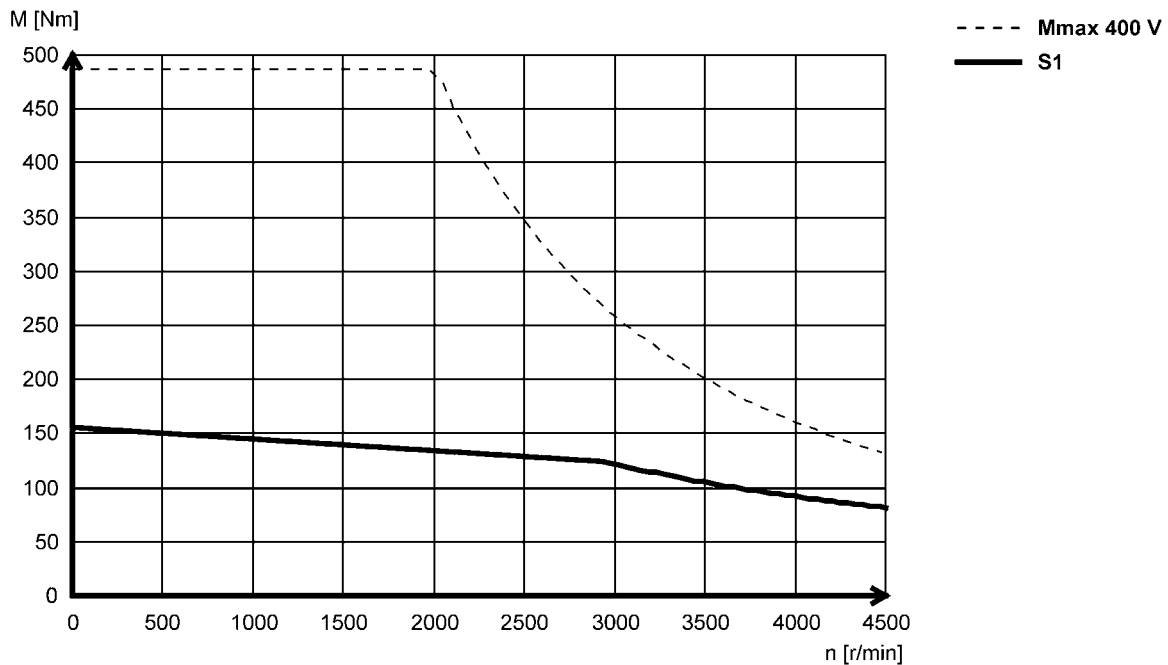

► Other torque characteristics with Lenze inverters can be found at [www.lenze.de/dsc](http://www.lenze.de/dsc).

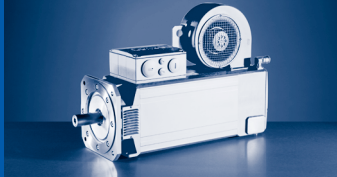

### Mains connection 3x 400 V

#### MQA26T05...2F□□

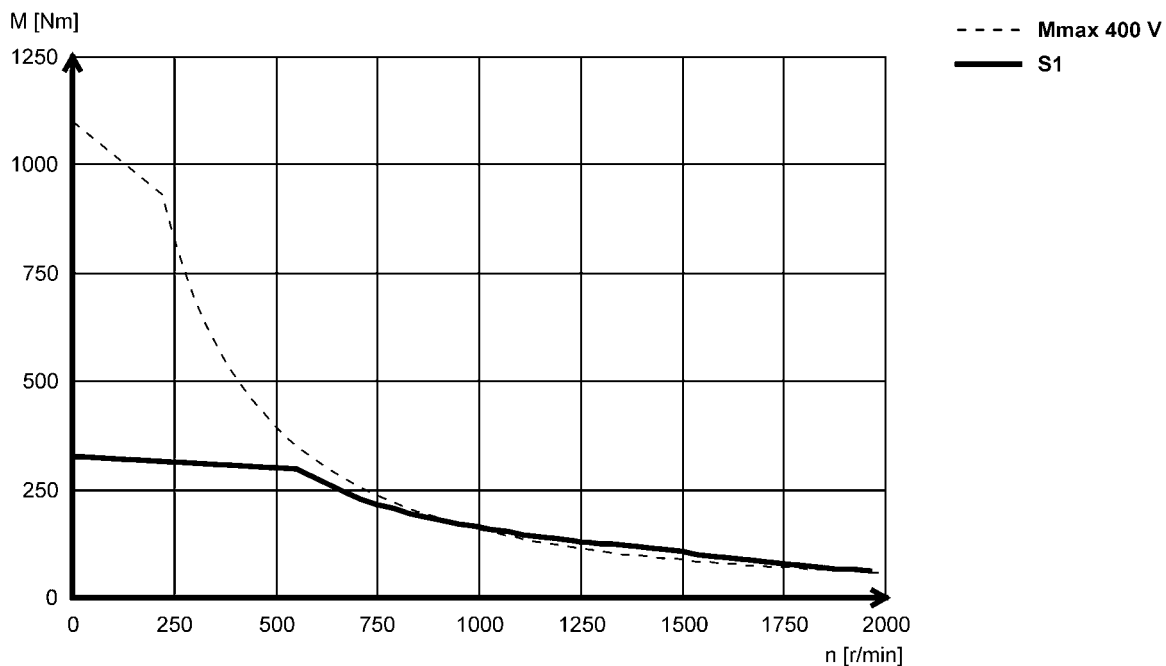

#### MQA26T10...2F□□

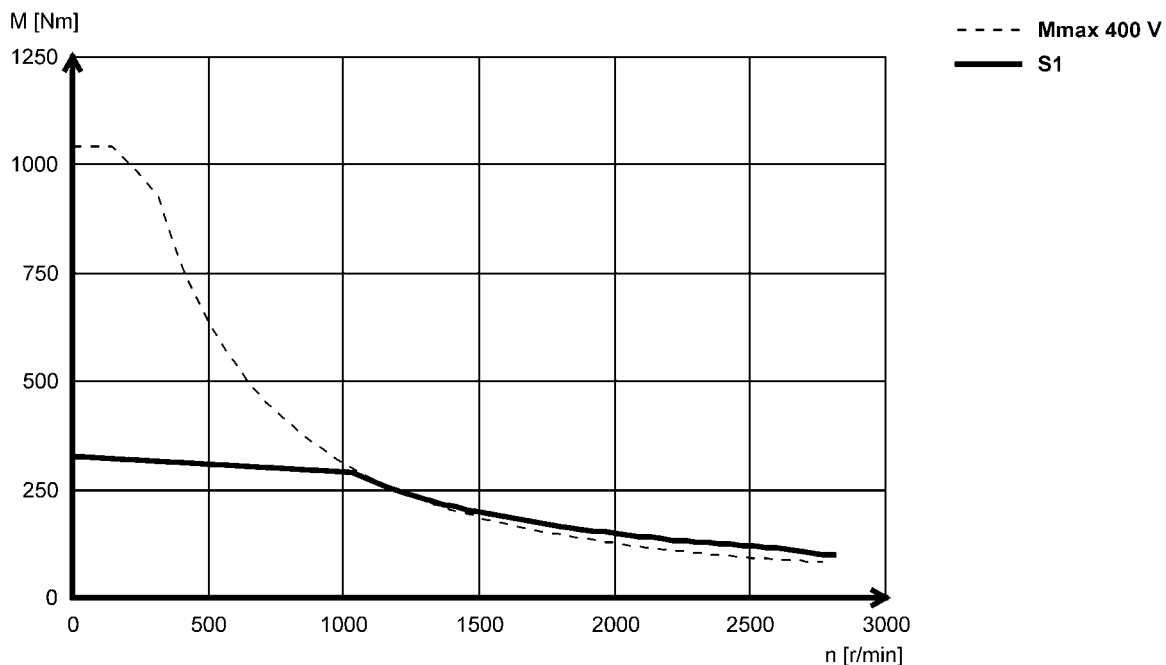

► Other torque characteristics with Lenze inverters can be found at [www.lenze.de/dsc](http://www.lenze.de/dsc).

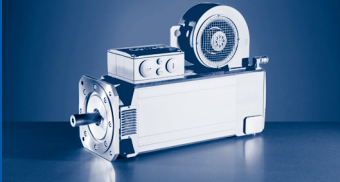

# MQA asynchronous servo motors

## Torque characteristics

Mains connection 3x 400 V

MQA26T12...2F□□

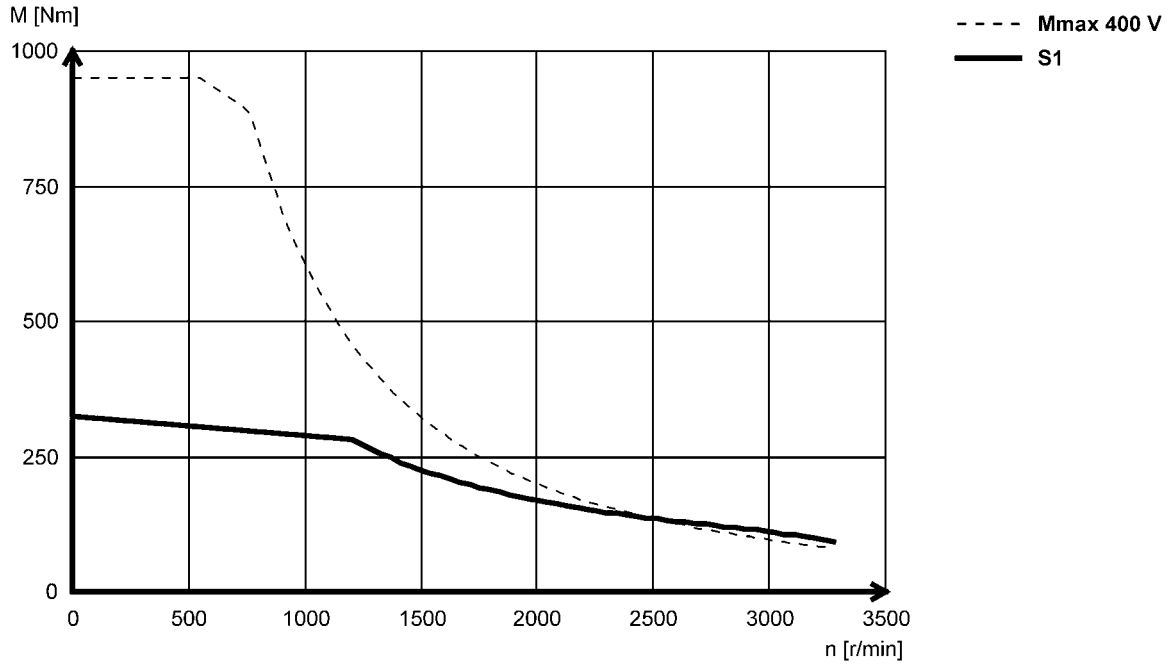

MQA26T22...2F□□

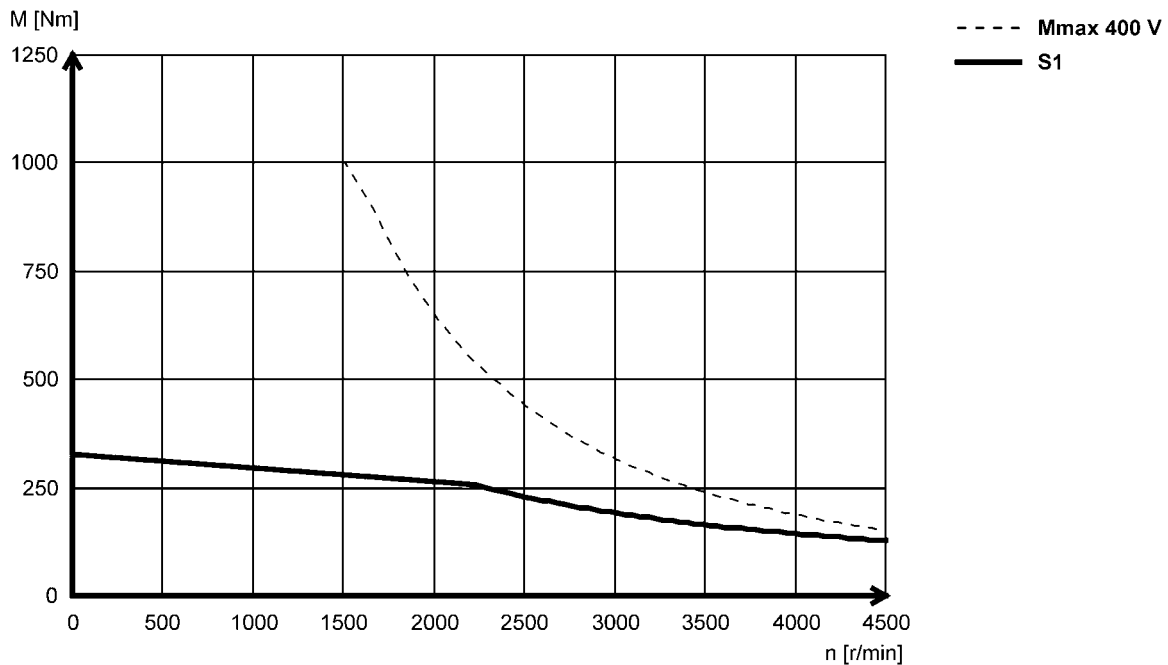

► Other torque characteristics with Lenze inverters can be found at [www.lenze.de/dsc](http://www.lenze.de/dsc).

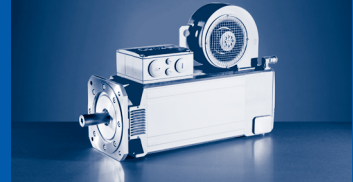

### Holding brakes

The servo motors can be equipped with integral spring-applied holding brakes. The voltages available for this model are 24 V DC and 230 V AC.

The brakes are active once the supply voltage is switched off (closed-circuit principle). Where the brakes are used purely as holding brakes, there is practically no wear on the friction surfaces.

#### Caution:

**The brakes used are not safety brakes in the sense that a reduction in torque may arise as a result of disruptive factors that cannot be influenced, e.g. oil ingress.**

The ohmic voltage drop along the cable must be taken into consideration in long motor supply cables and must be compensated for by a higher voltage at the line input.

The following applies for Lenze system cables:

$$U[V] = U_B[V] + 0.08 \frac{[V]}{[A] \cdot [m]} \cdot l_g[m] \cdot I_B[A]$$

If no suitable voltage (incorrect value, incorrect polarity) is applied to the brake, the brake will be applied and can be overheated and destroyed by the motor continuing to rotate. The shortest switching times of the brakes are achieved by DC switching of the voltage. A spark suppressor is required to suppress interference and to increase the service life of the relay contacts here.



*Spring-applied brake*

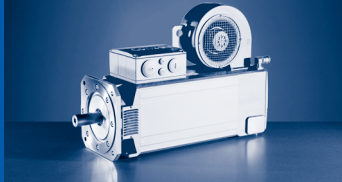

# MQA asynchronous servo motors

## Accessories

### Holding brake data

	U <sub>N, DC</sub> <sup>3, 6)</sup>	U <sub>N, AC</sub> <sup>4, 6)</sup>	M <sub>N</sub>	M <sub>N</sub>	M <sub>av</sub>	I <sub>N</sub> <sup>2)</sup>	J	t <sub>1</sub> <sup>1)</sup>	t <sub>2</sub> <sup>1)</sup>	Q <sub>E</sub> <sup>5)</sup>	m	J <sub>MB</sub>	J <sub>L</sub> /J <sub>MB</sub>
			20 °C	120 °C	120 °C								
	[V]	[V]	[Nm]	[Nm]	[Nm]	[A]	[kgcm <sup>2</sup> ]	[ms]	[ms]	[J]	[kg]	[kgcm <sup>2</sup> ]	
MQA20	24		90.0	80.0	50.0	3.13	6.88	70.0	220	18000	13.0	177	19.6
		230				0.37							
MQA22	24		150	130	80.0	3.75	18.1	50.0	260	23000	20.5	505	8.20
		230				0.44		130					
MQA26	24		300	260	200	3.13	70.4	175	320	51000	30.7	1405	12.7
		230				0.37			360				

### Holding brake data, reinforced design

	U <sub>N, DC</sub> <sup>3, 6)</sup>	U <sub>N, AC</sub> <sup>4, 6)</sup>	M <sub>N</sub>	M <sub>N</sub>	M <sub>av</sub>	I <sub>N</sub> <sup>2)</sup>	J	t <sub>1</sub> <sup>1)</sup>	t <sub>2</sub> <sup>1)</sup>	Q <sub>E</sub> <sup>5)</sup>	m	J <sub>MB</sub>	J <sub>L</sub> /J <sub>MB</sub>
			20 °C	120 °C	120 °C								
	[V]	[V]	[Nm]	[Nm]	[Nm]	[A]	[kgcm <sup>2</sup> ]	[ms]	[ms]	[J]	[kg]	[kgcm <sup>2</sup> ]	
MQA20	24		150	130	100	2.58	14.1	70.0	240	31000	15.4	185	33.0
		230				0.30							
MQA22	24		300	260	160	3.75	36.3	175	320	39000	26.0	523	14.1
		230				0.44		130					
MQA26	24		500	430	260	3.75	70.4	175	390	51000	30.8	1405	12.7
		230				0.44							

- 1) Engagement and disengagement times are valid for rated voltage ( $\pm 0\%$ ) and protective circuit for brakes with varistor for DC switching. The times may increase without a protective circuit.
- 2) The currents are the maximum values when the brake is cold (value used for dimensioning the current supply). The values for a motor at operating temperature are considerably lower.
- 3) With 24V DC brake: smoothed DC voltage, ripple  $\leq 1\%$ .
- 4) UR not possible in the case of a brake with 230 V supply voltage.
- 5) Maximum switching energy per emergency stop at  $n = 3000$  r/min for at least 2000 emergency stops.
- 6) Voltage tolerance: permanent magnet brakes  $-10 \dots 5\%$   
spring-applied brakes  $\pm 10\%$

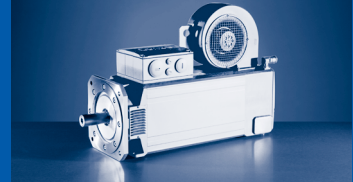

## Blower data 50 Hz

		Enclosure	Number of phases	$U_{\min}$	$U_{\max}$	$U_{N,AC}$	$P_N$	$I_N$
				[V]	[V]	[V]	[kW]	[A]
MQA20	F10 F1F	IP23s	1	210	250	230	0.090	0.39
	F30 F3F		3	360	440	400	0.067	0.13
MQA22	F10 F1F		1	210	250	230	0.26	1.10
	F30 F3F		3	360	440	400	0.23	0.37
MQA26	F10 F1F		1	210	250	230	0.40	1.75
	F30 F3F		3	360	440	400	0.43	0.68

## Blower data 60 Hz

		Enclosure	Number of phases	$U_{\min}$	$U_{\max}$	$U_{N,AC}$	$P_N$	$I_N$
				[V]	[V]	[V]	[kW]	[A]
MQA20	F10 F1F	IP23s	1	210	250	230	0.12	0.49
	F30 F3F		3	440	520	480	0.10	0.16
MQA22	F10 F1F		1	210	250	230	0.30	1.28
	F30 F3F		3	440	520	480	0.37	0.48
MQA26	F10 F1F		1	210	250	230	0.41	1.82
	F30 F3F		3	440	520	480	0.60	0.79

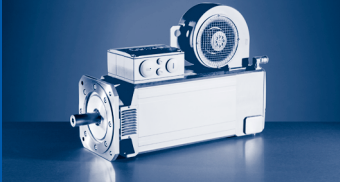

# MQA asynchronous servo motors

## Accessories

Tailored to meet the requirements of the various applications and necessary accuracies, the following feedback systems are available.

### Resolver

Stator-fed resolver with two stator windings offset by 90° and one rotor winding with transformer winding.

<b>Speed/angle sensor</b>	<sup>1)</sup>			<b>R50</b>
<b>Resolution</b>			[°]	0.80
Angle			[°]	-10 ... 10
<b>Accuracy</b>			[°]	-10 ... 10
<b>Absolute positioning</b>				1 revolution
<b>Max. speed</b>	$n_{max}$		[r/min]	8000
<b>Max. input voltage</b>	$U_{in,max}$		[V]	10.0
DC				
<b>Max. input frequency</b>	$f_{in,max}$		[kHz]	4.00
<b>Ratio</b>		$\pm 5\%$		0.30
Stator / rotor				
<b>Rotor impedance</b>	$Z_{ro}$		[Ω]	51 + j90
<b>Stator impedance</b>	$Z_{so}$		[Ω]	102 + j150
<b>Impedance</b>	$Z_{rs}$		[Ω]	44 + j76
<b>Min. insulation resistance</b>	$R$		[MΩ]	10.0
At DC 500 V				
<b>Number of pole pairs</b>				1
<b>Max. angle error</b>			[°]	-10 ... 10
<b>Inverter assignment</b>				E84AVTC E94A ECS EVS93

<sup>1)</sup> → 18 - Product key > speed/angle sensor



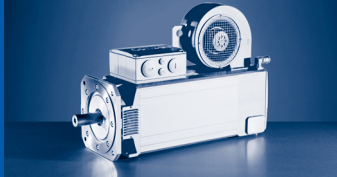

### Incremental encoder and SinCos absolute value encoder

Encoder type			TTL incremental		SinCos incremental	SinCos absolute value				
			T20	T40	S20	SRS	SRM	ECN	EQN	
Speed/angle sensor	1)		IG2048-5V-T	IG4096-5V-T	IG2048-5V-S	AS1024-8V-H	AM1024-8V-H	AS2048-5V-E	AM2048-5V-E	
Encoder type			Single-turn			Multi-turn	Single-turn	Multi-turn		
Pulses			2048	4096	2048	1024		2048		
Output signals			TTL			1 Vss				
Interfaces						Hiperface		EnDat		
Absolute revolutions			0		1	4096	1	4096		
Resolution Angle 2)		[°]	2.60		0.40					
Accuracy		[°]	-2 ... 2		-0.8 ... 0.8		-0.6 ... 0.6			
Min. input voltage DC	$U_{in,min}$	[V]	4.75	4.50	7.00	4.75				
Max. input voltage DC	$U_{in,max}$	[V]	5.25	5.50	12.0	5.25				
Max. speed	$n_{max}$	[r/min]	8789	5273	6000	12000				
Max. current consumption	$I_{max}$	[A]	0.15	0.10	0.080	0.15	0.25			
Limit frequency	$f_{max}$	[kHz]	300	180	200					
Inverter assignment			E84AVTC E94A ECS EVS93				E94A			

1) →  18 - Product key > speed/angle sensor

2) Dependent on inverter.

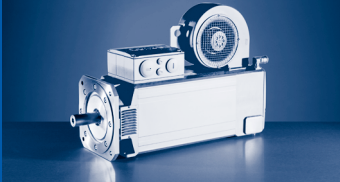

### Safety SinCos incremental encoder

- ▶ Safe encoder thanks to integrated functional safety

Encoder type			SinCos incremental
Speed/angle sensor	1)		S1S
			IG1024-5V-V
Encoder type			Single-turn
Pulses			1024
Output signals			1 Vss
Min. input voltage DC	$U_{in,min}$	[V]	4.75
Max. input voltage DC	$U_{in,max}$	[V]	5.25
Max. speed	$n_{max}$	[r/min]	8000
Max. current consumption	$I_{max}$	[A]	0.070
Limit frequency	$f_{max}$	[kHz]	200
Functional safety EN 13849-1 EN 954-1 IEC 61508			Up to Performance Level e Category 4 SIL3
Inverter assignment			E94A

1) → 18 - Product key > speed/angle sensor

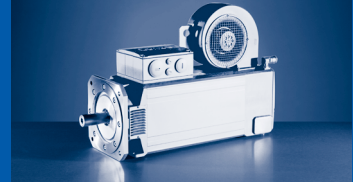

### Thermal sensor

The thermal sensors (1x KTY 83-110) used continuously monitor the motor temperature. The temperature signal is transmitted over the system cable of the feedback system to the servo controller.

This means that the temperature of the motor is determined with great accuracy in the permitted operating range and at the same time the overtemperature response configured in the controller is executed in the event of overtemperature in one of the winding phases.

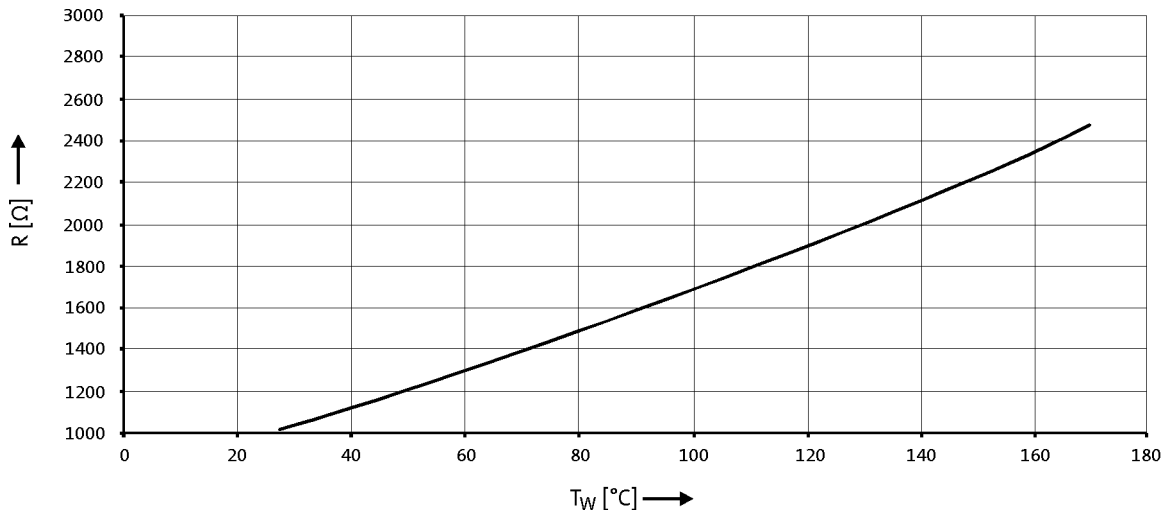

- ▶ If the detector is supplied with a measured current of 1 mA, the above relationship between the temperature and the resistance applies.

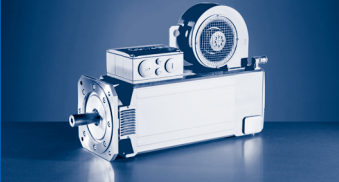

# MQA asynchronous servo motors

## Dimensions [mm]

### Motors with blower, B3

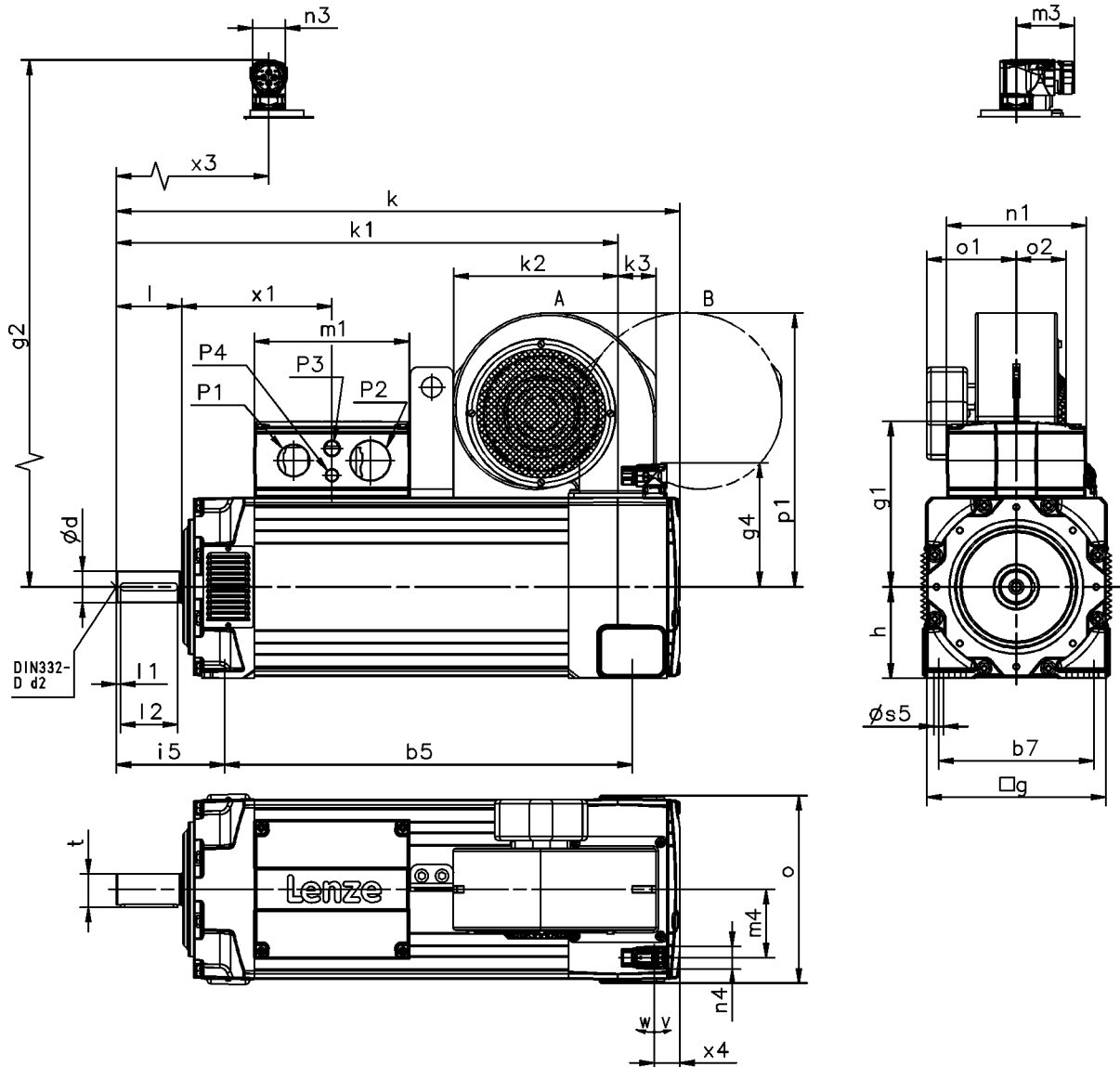

			MQA20	MQA22	MQA26
RS0 / E□□ / T□□ / S□□ / B0	k	[mm]	577	691	841
	$x_4$	[mm]	33.0	31.0	24.0
	$m_4$	[mm]	74.0	84.0	100
RS0 F1	k	[mm]	661	773	979
	$x_4$	[mm]	41.0	40.0	
	$m_4$	[mm]	70.0	76.0	96.0
E□□ / T□□ / S□□ / F1	k	[mm]	704	816	1017
	$x_4$	[mm]	46.0	45.0	40.0
	$m_4$	[mm]	70.0	76.0	96.0
RS0 / E□□ / T□□ / S□□ / F2	k	[mm]	729	848	1017
	$x_4$	[mm]	46.0	45.0	40.0
	$m_4$	[mm]	70.0	76.0	96.0

- ▶ Speed/angle sensor: RS0 / S□□ / E□□ / T□□
- ▶ Brake: B0 / F1 / F2

# MQA asynchronous servo motors

## Dimensions [mm]

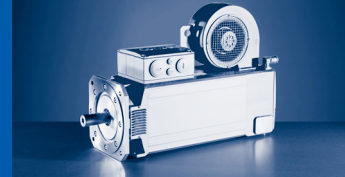

	g	g <sub>1</sub>	g <sub>2</sub>	g <sub>4</sub>	m <sub>1</sub>	m <sub>3</sub>	n <sub>1</sub>	n <sub>3</sub>	n <sub>4</sub>
	[mm]	[mm]	[mm]	[mm]	[mm]	[mm]	[mm]	[mm]	[mm]
MQA20	200	171	168	141	154	72	128	40	28
MQA22	220	203		153	190		171		
MQA26	260	256		173	238		212		

	o	P <sub>1</sub>	P <sub>2</sub>	P <sub>3</sub>	P <sub>4</sub>	v	w	x <sub>1</sub>	x <sub>3</sub>
	[mm]	[mm]	[mm]	[mm]	[mm]	[°]	[°]	[mm]	[mm]
MQA20	206	M32x1.5	M25x1.5	M20x1.5		195	80	155	192
MQA22	230	M50x1.5	M40x1.5		M16x1.5			174	
MQA26	266	M63x1.5	M50x1.5		218				

	d	d	d <sub>2</sub>	l	l <sub>1</sub>	l <sub>2</sub>	u	t
	k6	m6		-0.7 ... 0.3				
	[mm]	[mm]	[mm]		[mm]	[mm]	[mm]	[mm]
MQA20	38		M12	80	5.0	70	10.0	41
MQA22			M20	110		100	16.0	59
MQA26		55						

	h	b <sub>5</sub>	b <sub>7</sub>	s <sub>5</sub>	i <sub>5</sub>
	[mm]	[mm]	[mm]	[mm]	[mm]
MQA20	100	386	160	11.5	134
MQA22	112	500	190		133
MQA26	132	605	215		14.0

	F10 / F30						F1F / F3F						
	k <sub>1</sub>	k <sub>2</sub>	k <sub>3</sub>	o <sub>1</sub>	o <sub>2</sub>	p <sub>1</sub>	k <sub>1</sub>	k <sub>2</sub>	k <sub>3</sub>	o <sub>1</sub>	o <sub>2</sub>	p <sub>1</sub>	
	[mm]	[mm]	[mm]	[mm]	[mm]	[mm]	[mm]	[mm]	[mm]	[mm]	[mm]	[mm]	[mm]
MQA20	498	152	32.0	118	47.0	276	498	152	32.0	118	124	276	
MQA22	615	201	47.0	104	63.0	336	615	201	47.0	104	144	336	
MQA26	764	221	60.0	120	86.0	391	764	221	60.0	120	140	391	

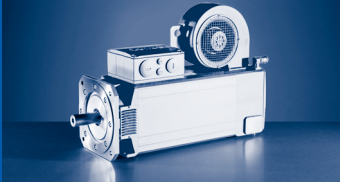

# MQA asynchronous servo motors

## Dimensions [mm]

### Motors with blower, B5

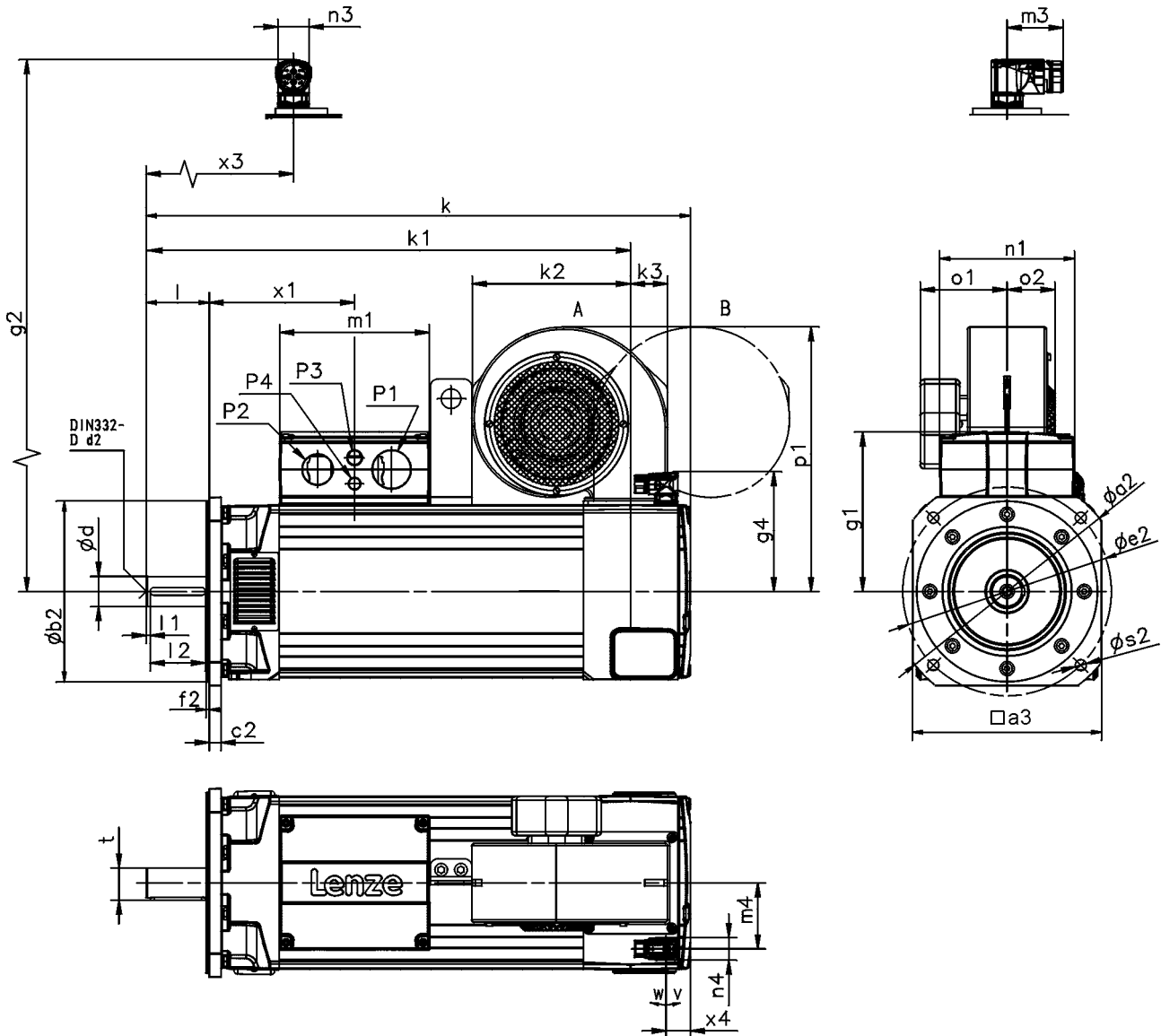

			MQA20	MQA22	MQA26
RS0 / E□□ / T□□ / S□□ / B0	k	[mm]	577	691	841
	$x_4$	[mm]	33.0	31.0	24.0
	$m_4$	[mm]	74.0	84.0	100
RS0 F1	k	[mm]	661	773	979
	$x_4$	[mm]	41.0	40.0	
	$m_4$	[mm]	70.0	76.0	96.0
E□□ / T□□ / S□□ / F1	k	[mm]	704	816	1017
	$x_4$	[mm]	46.0	45.0	40.0
	$m_4$	[mm]	70.0	76.0	96.0
RS0 / E□□ / T□□ / S□□ / F2	k	[mm]	729	848	1017
	$x_4$	[mm]	46.0	45.0	40.0
	$m_4$	[mm]	70.0	76.0	96.0

- ▶ Speed/angle sensor: RS0 / S□□ / E□□ / T□□
- ▶ Brake: B0 / F1 / F2

# MQA asynchronous servo motors

## Dimensions [mm]

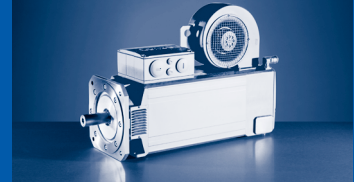

	g	g <sub>1</sub>	g <sub>2</sub>	g <sub>4</sub>	m <sub>1</sub>	m <sub>3</sub>	n <sub>1</sub>	n <sub>3</sub>	n <sub>4</sub>
	[mm]	[mm]	[mm]	[mm]	[mm]	[mm]	[mm]	[mm]	[mm]
<b>MQA20</b>	200	171	168	141	154	72	128	40	28
<b>MQA22</b>	220	203		153	190		171		
<b>MQA26</b>	260	256		173	238		212		

	o	P <sub>1</sub>	P <sub>2</sub>	P <sub>3</sub>	P <sub>4</sub>	v	w	x <sub>1</sub>	x <sub>3</sub>
	[mm]	[mm]	[mm]	[mm]	[mm]	[°]	[°]	[mm]	[mm]
<b>MQA20</b>	206	M32x1.5	M25x1.5	M20x1.5	M16x1.5	195	80	155	192
<b>MQA22</b>	230	M50x1.5	M40x1.5					174	
<b>MQA26</b>	266	M63x1.5	M50x1.5					218	

	d	d	d <sub>2</sub>	l	l <sub>1</sub>	l <sub>2</sub>	u	t	
	k6	m6		-0.7 ... 0.3					
	[mm]	[mm]	[mm]		[mm]	[mm]	[mm]	[mm]	
<b>MQA20</b>	38		M12	80	5.0	70	10.0	41	
<b>MQA22</b>									
<b>MQA26</b>		55	M20	110		100	16.0	59	

			MQA20	MQA22	MQA26
			FF215	FF265	FF350
a <sub>2</sub>		[mm]	250	300	400
a <sub>3</sub>		[mm]	196	240	320
b <sub>2</sub>	j6	[mm]	180	230	
b <sub>2</sub>	h6	[mm]			300
c <sub>2</sub>		[mm]		15	
e <sub>2</sub>		[mm]	215	265	350
f <sub>2</sub>		[mm]		4.0	5.0
s <sub>2</sub>		[mm]		14	18

	F10 / F30						F1F / F3F					
	k <sub>1</sub>	k <sub>2</sub>	k <sub>3</sub>	o <sub>1</sub>	o <sub>2</sub>	p <sub>1</sub>	k <sub>1</sub>	k <sub>2</sub>	k <sub>3</sub>	o <sub>1</sub>	o <sub>2</sub>	p <sub>1</sub>
	[mm]	[mm]	[mm]	[mm]	[mm]	[mm]	[mm]	[mm]	[mm]	[mm]	[mm]	[mm]
<b>MQA20</b>	498	152	32.0	118	47.0	276	498	152	32.0	118	124	276
<b>MQA22</b>	615	201	47.0	104	63.0	336	615	201	47.0	104	144	336
<b>MQA26</b>	764	221	60.0	120	86.0	391	764	221	60.0	120	140	391

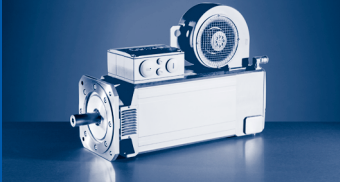

## MQA asynchronous servo motors

Dimensions [mm]



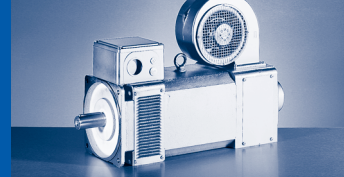

## Mains connection 3x 400 V

	$n_N$	$M_0$	$M_{max}$	$M_N$	$P_N$	$I_0$	$I_N$	$U_{N, AC}$	$f_N$	$J^{1)}$	$\eta_{100\%}$
	[r/min]	[Nm]	[Nm]	[Nm]	[kW]	[A]	[A]	[V]	[Hz]	[kgcm <sup>2</sup> ]	[%]
MDFQA□□160-32, 18, Y	498	480	1400	433	22.6	56.0	51.5	360	18	2900	81
MDFQA□□160-32, 31, Δ	890	480	1400	434	40.5	95.0	87.0	355	31	2900	89
MDFQA□□160-32, 44, Y	1280	470	1400	410	55.0	130	116	340	44	2900	91
MDFQA□□160-32, 78, Δ	2295	470	1400	395	95.0	230	196	340	78	2900	93

  

	$R_1$	$R_{UV\ 20^\circ C}$	$R_{UV\ 150^\circ C}$	$R_2$	$L_{1\sigma}$	$L$	$L_{2\sigma}$	$n_{max}^{2)}$	$m^{1)}$
	[Ω]	[Ω]	[Ω]	[Ω]	[mH]	[mH]	[mH]	[r/min]	[kg]
MDFQA□□160-32, 18, Y	0.22	0.45	0.60	0.20	2.65	73.8	2.23	6500	300
MDFQA□□160-32, 31, Δ		0.15	0.20			76.1			
MDFQA□□160-32, 44, Y	0.040	0.078	0.10	0.040	0.47	15.6	0.39		
MDFQA□□160-32, 78, Δ		0.026	0.035		0.48	16.2	0.38		

<sup>1)</sup> Without brake.

<sup>2)</sup> Mechanically permissible maximum speed.

The data in the  $R_1$ ,  $L_{1\sigma}$ ,  $L_h$ ,  $R_2'$  and  $L_{2\sigma}'$  columns is based on a single-phase equivalent circuit diagram at 20°C.

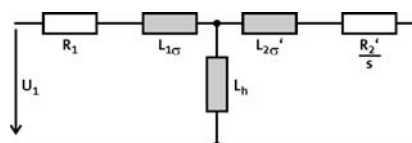

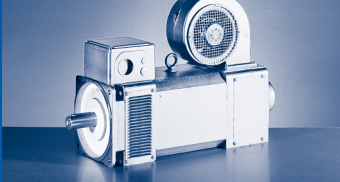

# MDFQA asynchronous servo motors

## Rated data

### Permissible radial and axial forces

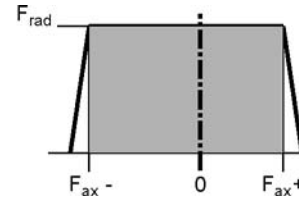
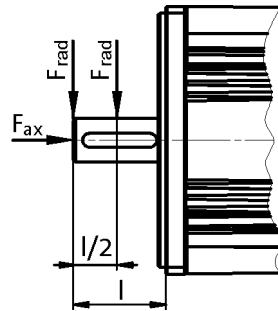

#### Application of force at l/2

	Bearing service life $L_{10}$														
	5000 h			10000 h			20000 h			30000 h			50000 h		
	$F_{rad}$	$F_{ax,-}$	$F_{ax,+}$	$F_{rad}$	$F_{ax,-}$	$F_{ax,+}$	$F_{rad}$	$F_{ax,-}$	$F_{ax,+}$	$F_{rad}$	$F_{ax,-}$	$F_{ax,+}$	$F_{rad}$	$F_{ax,-}$	$F_{ax,+}$
	[N]	[N]	[N]	[N]	[N]	[N]	[N]	[N]	[N]	[N]	[N]	[N]	[N]	[N]	[N]
<b>MDFQA□□160</b>	5400	-3610	2530	4330	-2650	1570	3480	-1940	860	3070	-1610	530	2620	-1280	200

#### Application of force at l

	Bearing service life $L_{10}$														
	5000 h			10000 h			20000 h			30000 h			50000 h		
	$F_{rad}$	$F_{ax,-}$	$F_{ax,+}$	$F_{rad}$	$F_{ax,-}$	$F_{ax,+}$	$F_{rad}$	$F_{ax,-}$	$F_{ax,+}$	$F_{rad}$	$F_{ax,-}$	$F_{ax,+}$	$F_{rad}$	$F_{ax,-}$	$F_{ax,+}$
	[N]	[N]	[N]	[N]	[N]	[N]	[N]	[N]	[N]	[N]	[N]	[N]	[N]	[N]	[N]
<b>MDFQA□□160</b>	4950	-3400	2320	3970	-2490	1410	3200	-1820	740	2820	-1510	430	2410	-1200	120

- ▶ The values for the bearing service life  $L_{10}$  refer to an average speed of 3000 r/min. Depending on the ambient temperatures, the service life of the bearings is also reduced by the grease lifetime.

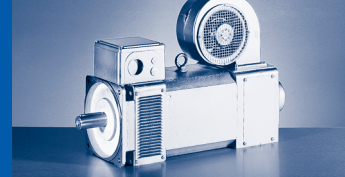

### Mains connection 3 x 400 V and switching frequency 8 kHz

#### Y-connection motors

					E94A□□	E0594
					$I_N$	41.0
					$I_{0,max}$	118.0
MDFQA	$M_N$	$n_N$	$I_N$	$P_N$	$I_{max}$	118.0
160-32	433.0	498	51.5	22.60	$M_0$	342.0
					$M_N$	342.0
					$M_{0,max}$	1064.0
					$M_{max}$	1064.0
					$n_{eto}$	-

					E94A□□	E1454	E1724	E2024
					$I_N$	102.0	120.0	131.0
					$I_{0,max}$	261.0	310.0	364.0
MDFQA	$M_N$	$n_N$	$I_N$	$P_N$	$I_{max}$	261.0	310.0	364.0
160-32	410.0	1280	115.5	55.00	$M_0$	363.0	433.0	470.0
					$M_N$	363.0	410.0	410.0
					$M_{0,max}$	991.0	1177.0	1375.0
					$M_{max}$	991.0	1177.0	1375.0
					$n_{eto}$	-	-	-

#### Δ connected motors

					E94A□□	E0864	E1044	E1454
					$I_N$	73.0	78.0	102.0
					$I_{0,max}$	172.0	208.0	261.0
MDFQA	$M_N$	$n_N$	$I_N$	$P_N$	$I_{max}$	172.0	208.0	261.0
160-32	434.0	890	87.0	40.50	$M_0$	350.0	378.0	480.0
					$M_N$	350.0	378.0	434.0
					$M_{0,max}$	915.0	1110.0	1390.0
					$M_{max}$	915.0	1110.0	1390.0
					$n_{eto}$	-	-	-

					E94A□□	E2454	E2924	E3664
					$I_N$	160.0	191.0	240.0
					$I_{0,max}$	441.0	526.0	659.0
MDFQA	$M_N$	$n_N$	$I_N$	$P_N$	$I_{max}$	441.0	526.0	659.0
160-32	395.0	2295	195.5	95.00	$M_0$	308.0	380.0	470.0
					$M_N$	308.0	380.0	395.0
					$M_{0,max}$	881.0	1048.0	1301.0
					$M_{max}$	881.0	1048.0	1301.0
					$n_{eto}$	-	-	-

- ▶  $I...$  [A],  $M...$  [Nm],  $n...$  [r/min],  $P...$  [kW]
- ▶ If the motors are operated at a lower switching frequency, please contact your Lenze sales office!
- ▶ When operating at 4 kHz, the motor generates just 95 % of its rated torque with increased noise emissions.

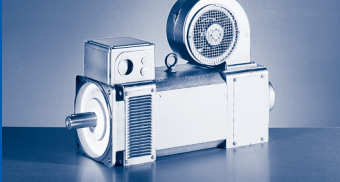

# MDFQA asynchronous servo motors

## EVS9300 servo inverter selection tables

### Mains connection 3 x 400 V and switching frequency 8 kHz

#### Y-connection motors

					EVS	9328-E□	9329-E□	9330-E□
					$I_N$	47.0	59.0	89.0
					$I_{0,max}$	47.0	52.0	80.0
MDFQA	$M_N$	$n_N$	$I_N$	$P_N$	$I_{max}$	70.5	88.5	133.5
160-32	433.0	498	51.5	22.60	$M_0$	395.0	435.0	480.0
					$M_N$	395.0	433.0	433.0
					$M_{0,max}$	395.0	435.0	680.0
					$M_{max}$	615.0	795.0	1260.0
					$n_{eto}$	-	-	-

  

					EVS	9331-E□	9332-E□
					$I_N$	110.0	145.0
					$I_{0,max}$	110.0	126.0
MDFQA	$M_N$	$n_N$	$I_N$	$P_N$	$I_{max}$	165.0	217.5
160-32	410.0	1280	115.5	55.00	$M_0$	365.0	470.0
					$M_N$	365.0	410.0
					$M_{0,max}$	365.0	455.0
					$M_{max}$	630.0	850.0
					$n_{eto}$	-	-

#### Δ connected motors

					EVS	9330-E□	9331-E□	9332-E□
					$I_N$	89.0	110.0	145.0
					$I_{0,max}$	80.0	110.0	126.0
MDFQA	$M_N$	$n_N$	$I_N$	$P_N$	$I_{max}$	133.5	165.0	217.5
160-32	434.0	890	87.0	40.50	$M_0$	435.0	480.0	480.0
					$M_N$	434.0	434.0	434.0
					$M_{0,max}$	385.0	585.0	731.0
					$M_{max}$	668.0	850.0	1140.0
					$n_{eto}$	-	-	-

►  $I...$  [A],  $M...$  [Nm],  $n...$  [r/min],  $P...$  [kW]

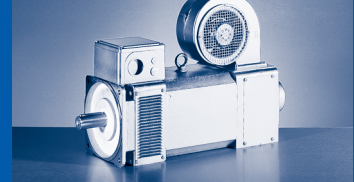

### Mains connection 3x 400 V

#### MDFQA160-32, 31, Y

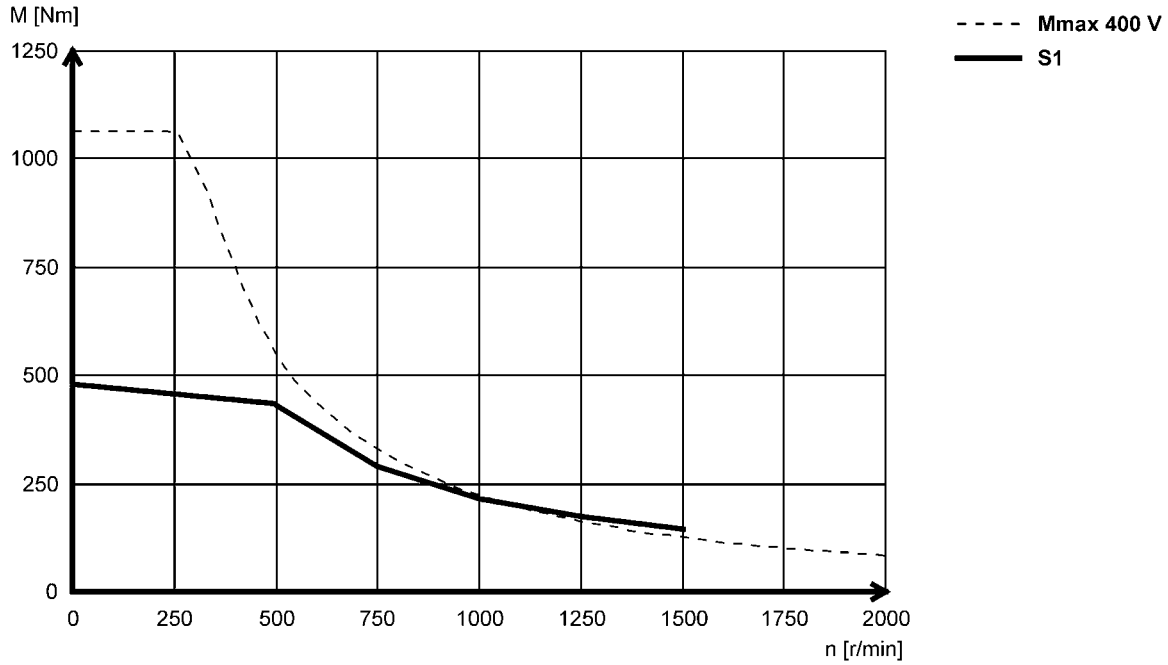

#### MDFQA160-32, 31, Δ

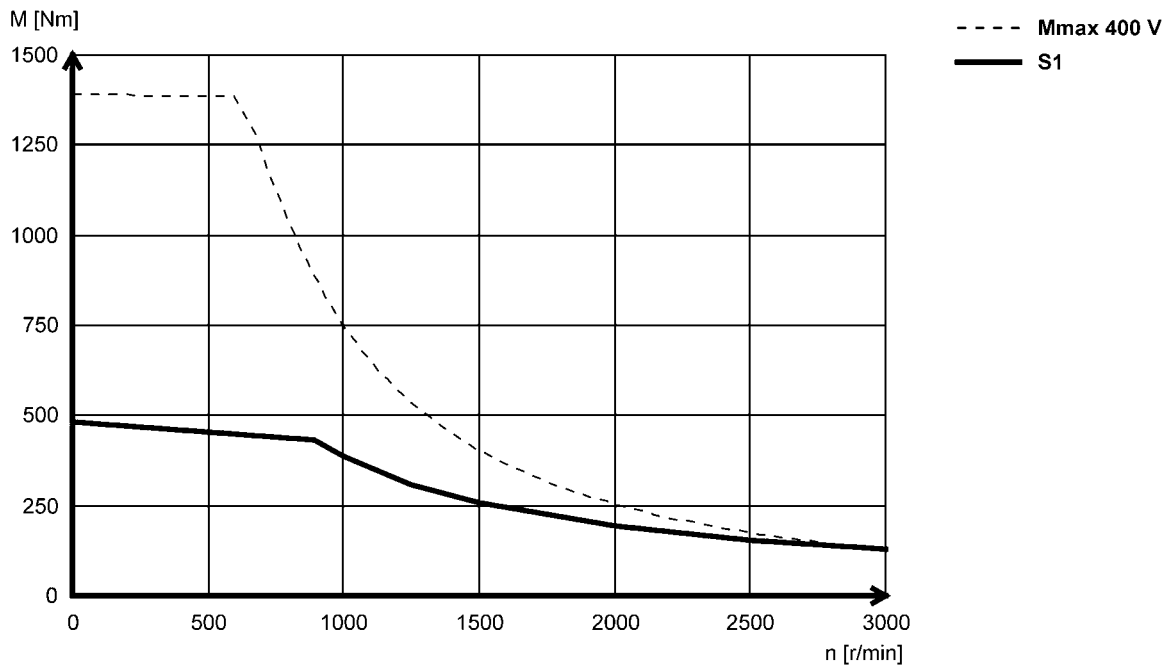

► Other torque characteristics with Lenze inverters can be found at [www.lenze.de/dsc](http://www.lenze.de/dsc).

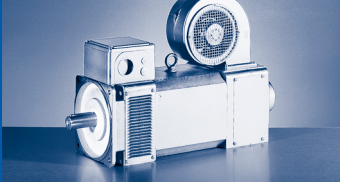

# MDFQA asynchronous servo motors

## Torque characteristics

Mains connection 3x 400 V

MDFQA160-32, 78, Y

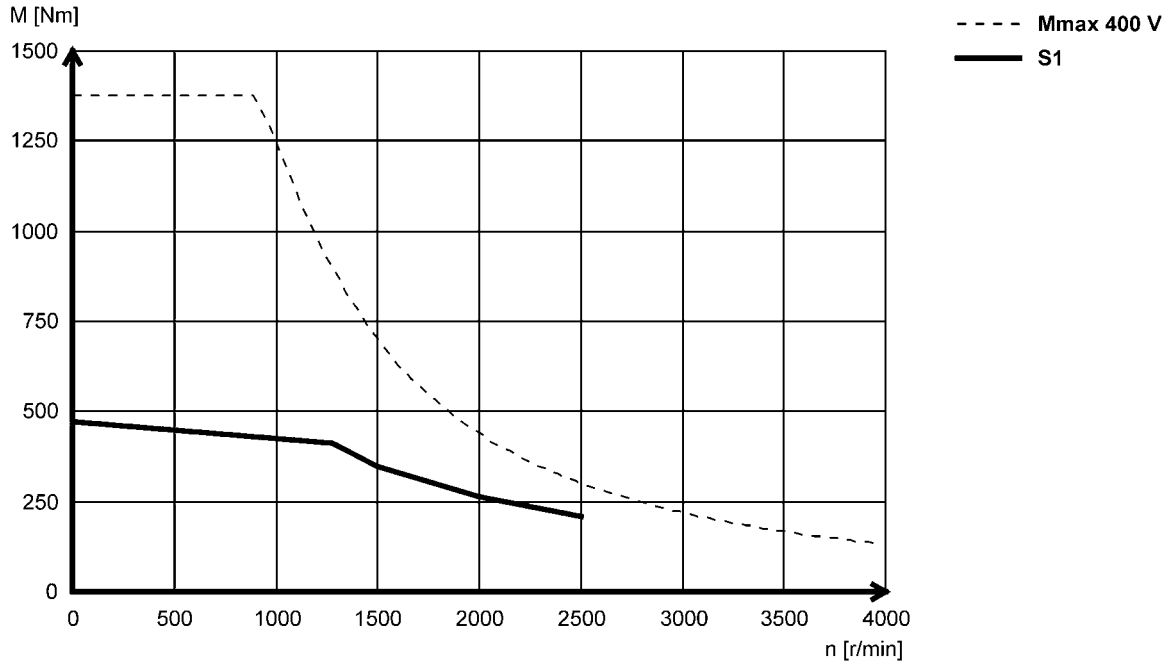

MDFQA160-32, 78, Δ

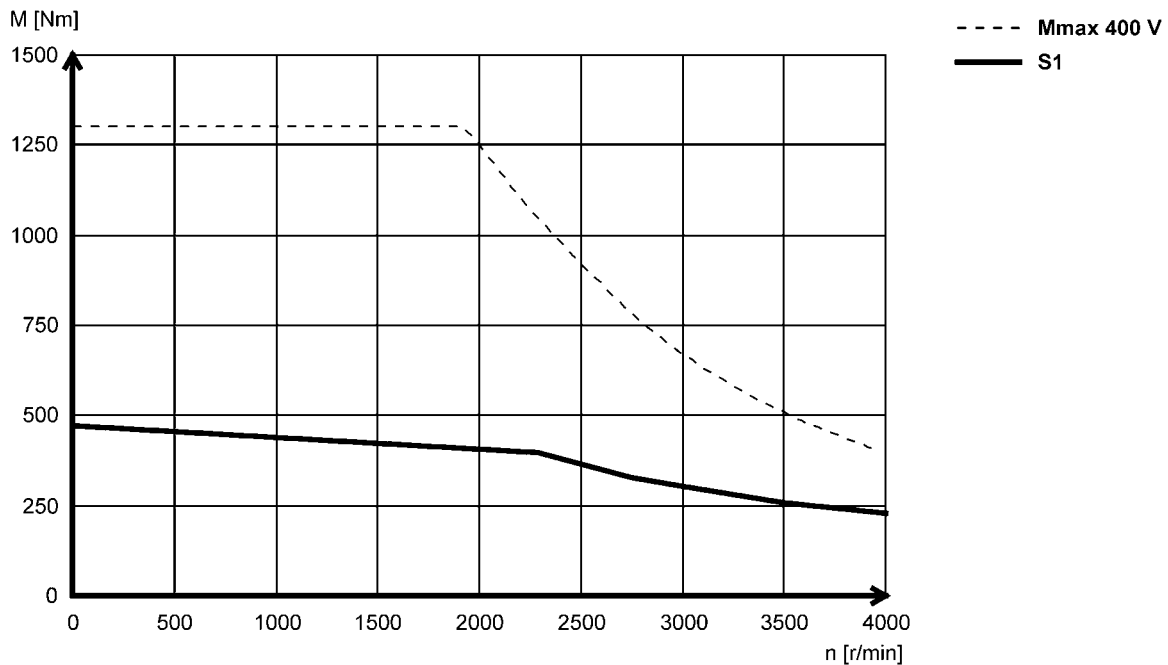

► Other torque characteristics with Lenze inverters can be found at [www.lenze.de/dsc](http://www.lenze.de/dsc).

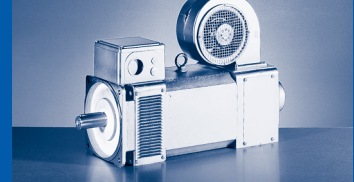

### Holding brakes

The MDFQA asynchronous servo motors can be equipped with integral spring-applied holding brakes. The voltages available for this model are 24 V DC and 205 V DC.

The brakes are active once the supply voltage is switched off (closed-circuit principle). Where the brakes are used purely as holding brakes, there is practically no wear on the friction surfaces.

#### Caution:

**The brakes used are not safety brakes in the sense that a reduction in torque may arise as a result of disruptive factors that cannot be influenced, e.g. oil ingress.**

The ohmic voltage drop along the cable must be taken into consideration in long motor supply cables and must be compensated for by a higher voltage at the line input.

The following applies for Lenze system cables:

$$U[V] = U_B[V] + 0.08 \frac{[V]}{[A] \cdot [m]} \cdot l_g[m] \cdot I_B[A]$$

If no suitable voltage (incorrect value, incorrect polarity) is applied to the brake, the brake will be applied and can be overheated and destroyed by the motor continuing to rotate. The shortest switching times of the brakes are achieved by DC switching of the voltage. A spark suppressor is required to suppress interference and to increase the service life of the relay contacts here.



*Spring-applied brake*

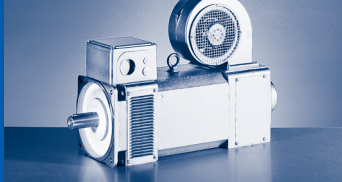

## MDFQA asynchronous servo motors

### Accessories

#### Holding brake data

		$U_{N,DC}^{4)}$	$M_N^{1)}$	$I_N^{5)}$	$J$	$t_1^{2,3)}$	$t_2^{2)}$	$Q_E^{-1)}$	$S_{h\ddot{u}}$
		[V]	[Nm]	[A]	[kgcm <sup>2</sup> ]	[ms]	[ms]	[J]	[1/h]
MDFQA□□160	F1	24	400	4.17	73.0	165	340	80000	19.0
	F5	205		0.49					

#### Holding brake data, reinforced design

		$U_{N,DC}^{4)}$	$M_N^{1)}$	$I_N^{5)}$	$J$	$t_1^{2,3)}$	$t_2^{2)}$	$Q_E^{-1)}$	$S_{h\ddot{u}}$
		[V]	[Nm]	[A]	[kgcm <sup>2</sup> ]	[ms]	[ms]	[J]	[1/h]
MDFQA□□160	F2	24	600	4.58	200	175	585	120000	15.0
	F6	205		0.54					

<sup>1)</sup> Rated torques are related to the relative speed  $\Delta n = 100$  r/min.

<sup>2)</sup> Engagement and disengagement times are valid for rated voltage ( $\pm 0\%$ ) and suppressor circuit for brakes with spark suppressors. The times may increase without a suppressor circuit. The operating times are mean values. Leakage depends on the type of rectifier, the air path and the coil current.

<sup>3)</sup> Engagement times with DC side switching, in the case of AC side switching  $t_1$  increases by a factor of about 10.

<sup>4)</sup> With 24 V DC brake: smoothed DC voltage, ripple  $\leq 1\%$ .

With 205 V DC brake: connection to 230 V AC through rectifier.

<sup>5)</sup> The currents are the maximum values when the brake is cold (value used for dimensioning the current supply). The values for a motor at operating temperature are considerably lower.

<sup>6)</sup> Maximum switching energy per emergency stop at  $n = 3000$  r/min for at least 2000 emergency stops.



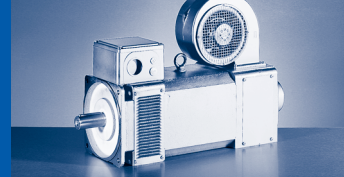

### Blower data 50 Hz

	Enclosure	Number of phases					
			$U_{min}$	$U_{max}$	$U_{N, AC}$	$P_N$	$I_N$
			[V]	[V]	[V]	[kW]	[A]
<b>MDFQA□□160</b>	IP23s	3	350	540	400	0.65	1.40

### Blower data 60 Hz

	Enclosure	Number of phases					
			$U_{min}$	$U_{max}$	$U_{N, AC}$	$P_N$	$I_N$
			[V]	[V]	[V]	[kW]	[A]
<b>MDFQA□□160</b>	IP23s	3	350	540	400	0.65	1.40

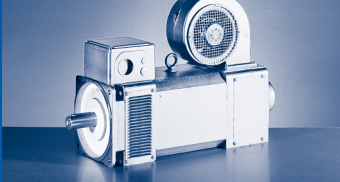

# MDFQA asynchronous servo motors

## Accessories

Tailored to meet the requirements of the various applications and necessary accuracies, the following feedback systems are available.

### Resolver

Stator-fed resolver with two stator windings offset by 90° and one rotor winding with transformer winding.

<b>Built-on accessories</b>	<sup>1)</sup>			<b>BS RS</b>
<b>Resolution</b>				
Angle			[°]	0.80
<b>Accuracy</b>				
			[°]	-10 ... 10
<b>Absolute positioning</b>				
				1 revolution
<b>Max. speed</b>				
	$n_{\max}$		[r/min]	8000
<b>Max. input voltage</b>				
DC	$U_{\text{in,max}}$		[V]	10.0
<b>Max. input frequency</b>				
	$f_{\text{in,max}}$		[kHz]	4.00
<b>Ratio</b>				
Stator / rotor		$\pm 5\%$		0.30
<b>Rotor impedance</b>				
	$Z_{\text{ro}}$		[ $\Omega$ ]	51 + j90
<b>Stator impedance</b>				
	$Z_{\text{so}}$		[ $\Omega$ ]	102 + j150
<b>Impedance</b>				
	$Z_{\text{rs}}$		[ $\Omega$ ]	44 + j76
<b>Min. insulation resistance</b>				
At DC 500 V	R		[M $\Omega$ ]	10.0
<b>Number of pole pairs</b>				
				1
<b>Max. angle error</b>				
			[°]	-10 ... 10
<b>Inverter assignment</b>				
				E84AVTC E94A ECS EVS93

<sup>1)</sup> →  21 - Product key > built-on accessories

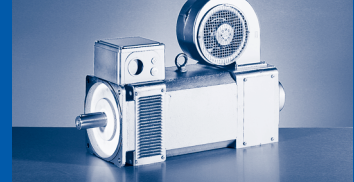

### Incremental encoder and SinCos absolute value encoder

Encoder type			TTL incremental	SinCos incremental
Built-on accessories	1)		BI IG	
			IG2048-5V-T	IG2048-5V-S
Encoder type				Single-turn
Pulses			2048	
Output signals			TTL	1 V <sub>SS</sub>
Interfaces				
Absolute revolutions			0	
Resolution Angle <sup>2)</sup>		[°]	2.60	0.40
Accuracy		[°]	-2 ... 2	-0.8 ... 0.8
Min. input voltage DC	$U_{in,min}$	[V]	4.75	4.50
Max. input voltage DC	$U_{in,max}$	[V]	5.25	5.50
Max. speed	$n_{max}$	[r/min]	8789	5273
Max. current consumption	$I_{max}$	[A]	0.15	0.10
Limit frequency	$f_{max}$	[kHz]	300	180
Inverter assignment			E84AVTC E94A ECS EVS93	

1) →  21 - Product key > built-on accessories

2) Dependent on inverter.

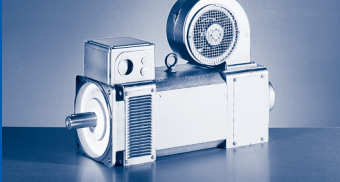

### Thermal sensor

The thermal sensors (1x KTY 83-110) used continuously monitor the motor temperature. The temperature signal is transmitted over the system cable of the feedback system to the servo controller.

This means that the temperature of the motor is determined with great accuracy in the permitted operating range and at the same time the overtemperature response configured in the controller is executed in the event of overtemperature in one of the winding phases.

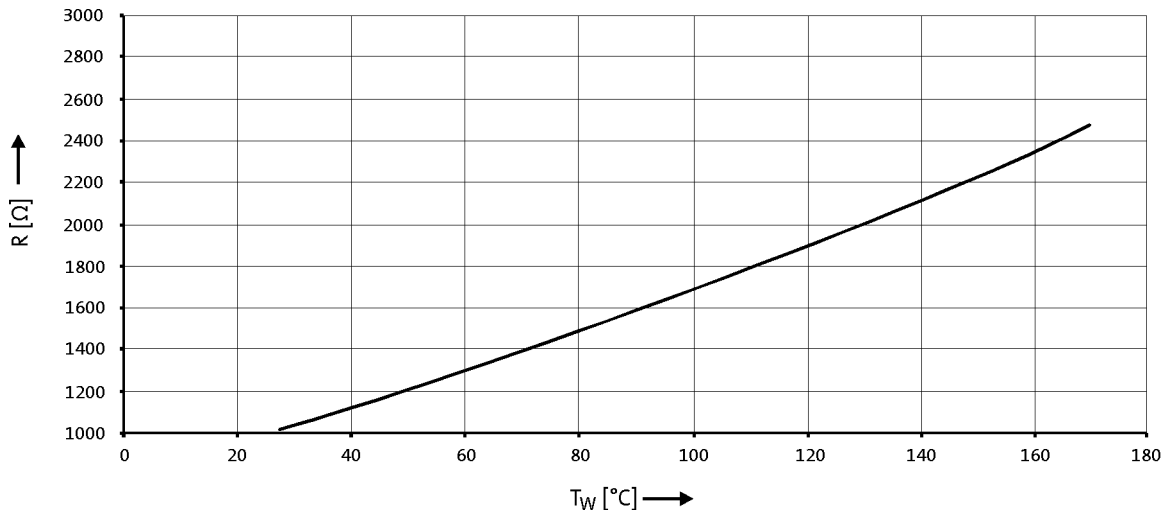

- If the detector is supplied with a measured current of 1 mA, the above relationship between the temperature and the resistance applies.

# MDFQA asynchronous servo motors

## Dimensions [mm]

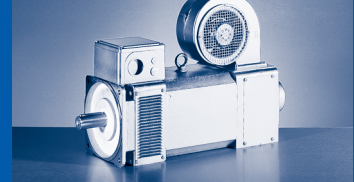

MDFQA□□160-32  
B35A400

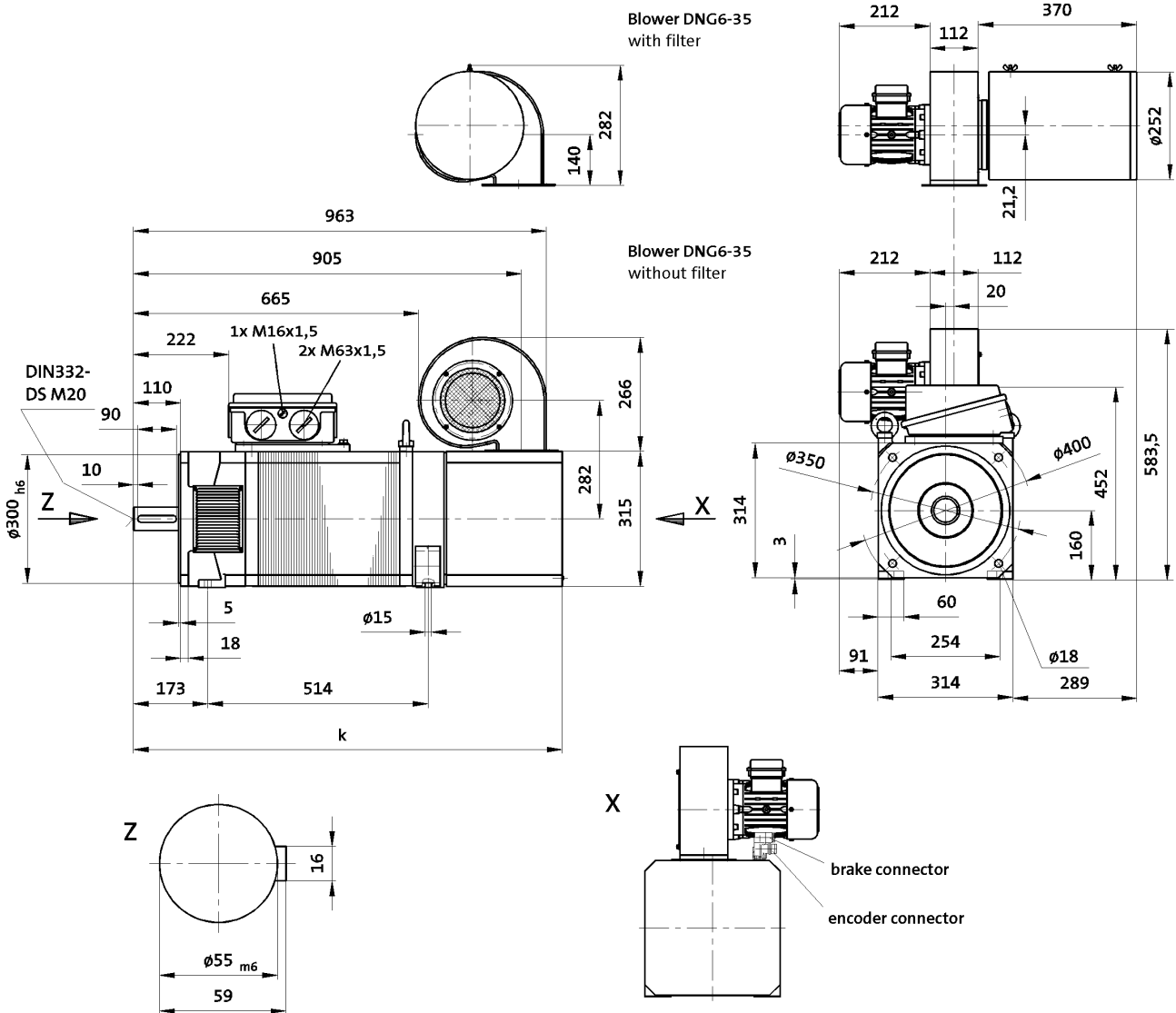

NN	k	[mm]	1000
RS	k	[mm]	1000
IG (ITD21 / ITD22)	k	[mm]	1000
AG	k	[mm]	1000

BR	k	[mm]	1000
BS	k	[mm]	1000
BI (ITD21 / ITD22)	k	[mm]	1000
BA	k	[mm]	1000

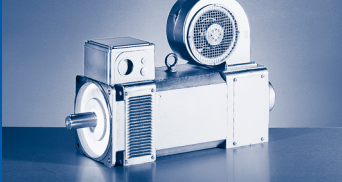

## MDFQA asynchronous servo motors

Dimensions [mm]

7

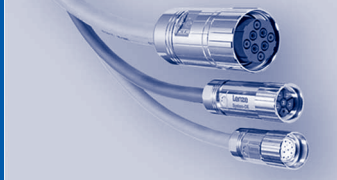

The motor cable is selected from the available cable cross-sections using the socket identifier M01/M02... (system cables – cable end product key).

- ▶ The following pages describe the socket/motor assignment.
- ▶ The available cable cross-sections can be found in the system cables product key.
- ▶ It is not possible to connect the MCS06 and MDSKS036 synchronous servo motors via terminal boxes.
- ▶ The cross-section of a cable and its current capacity must always be checked when a cable is connected to a motor through a terminal box.
- ▶ Every possible combination is described in detail in the System Cables Manual.
- ▶ This manual can be found at [www.lenze.com](http://www.lenze.com) - **Services & Downloads - Technical documentation - Library - X1\_Accessories - X15\_External\_accessories.**



## System cables

Assignment of socket to servo motor

### MCS synchronous servo motors

	Power / brake		Blower	
	Screw cap socket	SpeedTec socket	Screw cap socket	SpeedTec socket
MCS06	M01	M04		
MCS09				
MCS12D17	M01	M04	L02	L04
MCS12D20				
MCS12D35			L02	L04
MCS12D41				
MCS12H14			L02	L04
MCS12H15				
MCS12H30				
MCS12H34			L02	L04
MCS12H35				
MCS12L17			L02	L04
MCS12L20				
MCS12L39			L02	L04
MCS12L41				
MCS14D14			L02	L04
MCS14D15				
MCS14D30			L02	L04
MCS14D36				
MCS14H12			L02	L04
MCS14H15				
MCS14H28			M02 M03	M05 M06
MCS14H32				
MCS14L14	M01	M04	L02	L04
MCS14L15				
MCS14L30	M02	M05	L02	L04
MCS14L32	M03	M06		
MCS14P11	M01	M04	L02	L04
MCS14P14				
MCS14P26	M02	M05	L02	L04
MCS14P32	M03	M06		



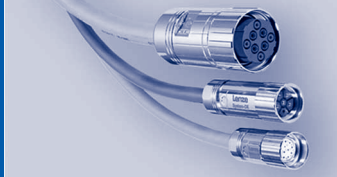

	Power / brake		Blower	
	Screw cap socket	SpeedTec socket	Screw cap socket	SpeedTec socket
MCS19F12	M01	M04	L02	L04
MCS19F14				
MCS19F29	M02 M03	M05 M06	L02	L04
MCS19F30				
MCS19J12			L02	L04
MCS19J14	M01	M04		
MCS19J29	M03	M06	L02	L04
MCS19J30	M02 M03	M05 M06		
MCS19P12			L02	L04
MCS19P14	M01	M04		
MCS19P29	M03	M06	L02	L04
MCS19P30				

### MD□KS synchronous servo motors

	Power / brake		Blower	
	Screw cap socket	SpeedTec socket	Screw cap socket	SpeedTec socket
MDSKS□□056	M01	M04		
MDSKS□□071				
MDFKS□□071			L01	L03

## MCA asynchronou servo motors

	Power / brake		Blower	
	Screw cap socket	SpeedTec socket	Screw cap socket	SpeedTec socket
MCA10I40	M01	M04		
MCA13I34			L02	L04
MCA13I41				
MCA14L16			L02	L04
MCA14L20				
MCA14L35			L02	L04
MCA14L41				
MCA17N17			L02	L04
MCA17N23				
MCA17N35			L02	L04
MCA17N41				
MCA19S17			M02	M05
MCA19S23				
MCA19S35	M02	M05	L02	L04
MCA19S42	M03	M06		
MCA20X14...2F□□				
MCA20X29...2F□□	M03	M06	L02	L04
MCA21X17	M02 M03	M05 M06		
MCA21X25	M02	M05		
MCA21X35	M03	M06	L02	L04
MCA21X42	M02 M03	M05 M06		
MCA22P08...2F□□			L02	L04
MCA22P08...5F□□				
MCA22P14...2F□□				
MCA22P14...5F□□				
MCA22P17...2F□□				
MCA22P17...5F□□				
MCA22P29...2F□□				
MCA22P29...5F□□				
MCA26T05...2F□□				
MCA26T05...5F□□				
MCA26T10...2F□□				
MCA26T10...5F□□				
MCA26T12...2F□□				
MCA26T12...5F□□				
MCA26T22...2F□□				
MCA26T22...5F□□				

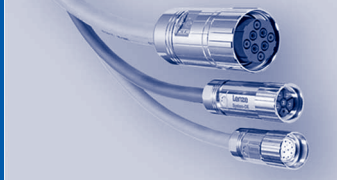

## MQA asynchronous servo motors

	Power / brake		Blower	
	Screw cap socket	SpeedTec socket	Screw cap socket	SpeedTec socket
MQA20L14...2F□□	M02	M05		
MQA20L29...2F□□	M03	M06		

## Feedback

	Feedback	
	Screw cap socket	SpeedTec socket
AM1024-8V-H	F02	F06
AM2048-5V-E		
AM32-5V-E	F03	F07
AS1024-8V-H	F02	F06
AS2048-5V-E	F03	F07
IG2048-5V-S		
IG2048-5V-T		
IG4096-5V-T	F02	F06
IG1024-5V-V		
IK4096-5V-T	F04	F08
RS0	F01	F05

### Motor connecting cables

Product series	Cable type	Connection cable	Cable length in decimetres	Cable end on the motor side (socket)	Cable end on the controller side
E Y P Motor		A	0 0 0 3 5 0 0 0 Minimum length Maximum length		
Fixed installation	0 0 0 3	1.0 mm <sup>2</sup>		M 0 1 Screw plug	A 0 0 Without plug-in connector
	0 0 0 4	1.5 mm <sup>2</sup>		M 0 4 SpeedTec	
	0 0 0 5	2.5 mm <sup>2</sup>			
	0 0 0 5	2.5 mm <sup>2</sup>		M 0 2 Screw plug	A 0 0 Without plug-in connector
	0 0 0 6	4.0 mm <sup>2</sup>		M 0 5 SpeedTec	
	0 0 0 7	6.0 mm <sup>2</sup>		M 0 3 Screw plug	A 0 0 Without plug-in connector
	0 0 0 8	10.0 mm <sup>2</sup>		M 0 6 SpeedTec	
Trailing cable	0 0 1 0	1.0 mm <sup>2</sup>		M 0 1 Screw plug	A 0 0 Without plug-in connector
	0 0 1 1	1.5 mm <sup>2</sup>		M 0 4 SpeedTec	
	0 0 1 2	2.5 mm <sup>2</sup>			
	0 0 1 2	2.5 mm <sup>2</sup>		M 0 2 Screw plug	A 0 0 Without plug-in connector
	0 0 1 3	4.0 mm <sup>2</sup>		M 0 5 SpeedTec	
	0 0 1 4	6.0 mm <sup>2</sup>		M 0 3 Screw plug	A 0 0 Without plug-in connector
	0 0 1 5	10.0 mm <sup>2</sup>		M 0 6 SpeedTec	
	0 0 1 6	16.0 mm <sup>2</sup>			

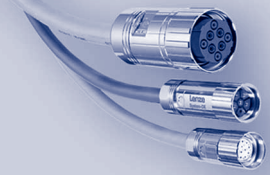

### Motor connecting cables

Product series	Cable type	Cable without plug-in connector	Cable length in decimetres	Cable end on the motor side	Cable end on the controller side
<b>E Y</b> <b>P</b> Motor		<b>Y</b>	<b>0 0 0 3</b> Minimum length <b>5 0 0 0</b> Maximum length		
Fixed installation	<b>0 0 0 3</b> <b>0 0 0 4</b> <b>0 0 0 5</b> <b>0 0 0 6</b> <b>0 0 0 7</b> <b>0 0 0 8</b> <b>0 0 0 9</b>	1.0 mm <sup>2</sup> 1.5 mm <sup>2</sup> 2.5 mm <sup>2</sup> 4.0 mm <sup>2</sup> 6.0 mm <sup>2</sup> 10.0 mm <sup>2</sup> 16.0 mm <sup>2</sup>		<b>A 0 0</b> Without plug-in connector	<b>A 0 0</b> Without plug-in connector
Trailing cable	<b>0 0 1 0</b> <b>0 0 1 1</b> <b>0 0 1 2</b> <b>0 0 1 3</b> <b>0 0 1 4</b> <b>0 0 1 5</b> <b>0 0 1 6</b>	1.0 mm <sup>2</sup> 1.5 mm <sup>2</sup> 2.5 mm <sup>2</sup> 4.0 mm <sup>2</sup> 6.0 mm <sup>2</sup> 10.0 mm <sup>2</sup> 16.0 mm <sup>2</sup>		<b>A 0 0</b> Without plug-in connector	<b>A 0 0</b> Without plug-in connector

### Feedback connecting cables

Product series	Cable type	Connection cable	Cable length in decimetres	Cable end on the motor side (socket)	Cable end on the controller side	For use with
<b>E Y</b> Feedback		<b>A</b>	<b>0 0 0 3</b> Minimum length <b>5 0 0 0</b> Maximum length			
Fixed installation	<b>0 0 1 7</b>	Resolver		<b>F 0 1</b> Screw plug <b>F 0 5</b> SpeedTec	<b>S 0 1</b> Sub-D plug <b>S 0 2</b> Sub-D plug <b>A 0 0</b> Without plug-in connector	EVS93..., ECS..., 931E... E94AS..., E94AM..., E84AVT...
	<b>0 0 2 1</b>	Sin/cos absolute value encoder (EnDat)		<b>F 0 3</b> Screw plug <b>F 0 7</b> SpeedTec	<b>S 0 3</b> Sub-D plug <b>A 0 0</b> Without plug-in connector	E94AS..., E94AM...
Trailing cable	<b>0 0 2 0</b>	Resolver		<b>F 0 1</b> Screw plug <b>F 0 5</b> SpeedTec	<b>S 0 4</b> Sub-D plug <b>S 0 5</b> Sub-D plug <b>A 0 0</b> Without plug-in connector	EVS93..., ECS..., 931E... E94AS..., E94AM..., E84AVT...
	<b>0 0 2 2</b>	Sin/cos absolute value encoder (EnDat)		<b>F 0 3</b> Screw plug <b>F 0 7</b> SpeedTec	<b>S 0 4</b> Sub-D plug <b>S 0 5</b> Sub-D plug <b>A 0 0</b> Without plug-in connector	EVS93..., ECS..., 931E... E94AS..., E94AM..., E84AVT...



### Feedback connecting cables

Product series	Cable type	Connection cable	Cable length in decimetres	Cable end on the motor side (socket)	Cable end on the controller side	For use with
<b>E Y</b>		<b>A</b>	<b>0 0 0 3</b> Minimum length <b>5 0 0 0</b> Maximum length			
	<b>F</b> Feedback					
Fixed installation	<b>0 0 1 8</b>	Sin/cos absolute value encoder (Hiperface) and incremental encoder (TTL, HTL)		<b>F 0 2</b> Screw plug <b>F 0 6</b> SpeedTec	<b>W 0 2</b> Sub-D plug <b>S 0 3</b> Sub-D plug <b>A 0 0</b> Without plug-in connector	EVS93..., ECS..., 931E... EVF93..., E94AYFLF E94AS..., E94AM..., E84AVT... E82xV... E84AVH..., E84AVT...
	<b>0 0 2 3</b>	Incremental encoder IK4096-5V-T (Renco R35i)		<b>F 0 4</b> Screw plug <b>F 0 8</b> SpeedTec	<b>W 0 2</b> Sub-D plug <b>S 0 3</b> Sub-D plug	EVS93..., ECS..., 931E... EVF93..., E94AYFLF E94AS..., E94AM..., E84AVT... E94P...
	<b>0 0 1 9</b>	Sin/cos absolute value encoder (Hiperface) and incremental encoder (TTL, HTL)		<b>F 0 2</b> Screw plug <b>F 0 6</b> SpeedTec	<b>S 0 6</b> Sub-D plug <b>A 0 0</b> Without plug-in connector	E94P...
Trailing cable	<b>0 0 1 9</b>	Sin/cos absolute value encoder (Hiperface) and incremental encoder (TTL, HTL)		<b>F 0 2</b> Screw plug <b>F 0 6</b> SpeedTec	<b>S 0 6</b> Sub-D plug <b>A 0 0</b> Without plug-in connector	E94P...
	<b>0 0 2 4</b>	Incremental encoder IK4096-5V-T (Renco R35i)		<b>F 0 2</b> Screw plug <b>F 0 6</b> SpeedTec	<b>W 0 4</b> Sub-D plug <b>S 0 3</b> Sub-D plug <b>A 0 0</b> Without plug-in connector	EVS93..., ECS..., 931E... EVF93..., E94AYFLF E94AS..., E94AM..., E84AVT... E82xV... E84AVH..., E84AVT...
	<b>0 0 2 4</b>	Incremental encoder IK4096-5V-T (Renco R35i)		<b>F 0 4</b> Screw plug <b>F 0 8</b> SpeedTec	<b>W 0 4</b> Sub-D plug <b>S 0 3</b> Sub-D plug <b>A 0 0</b> Without plug-in connector	EVS93..., ECS..., 931E... EVF93..., E94AYFLF E94AS..., E94AM..., E84AVT... E82xV... E84AVH..., E84AVT...

### Feedback connecting cables

Product series	Cable type	Cable without plug-in connector	Cable length in decimetres	Cable end on the motor side	Cable end on the controller side
<b>E Y</b>		<b>Y</b>			
<b>F</b>			<b>0 0 0 3</b> <b>5 0 0 0</b>		
Feedback			Minimum length Maximum length		
Fixed installation	<b>0 0 1 7</b>	Resolver		<b>A 0 0</b> Without plug-in connector	<b>A 0 0</b> Without plug-in connector
	<b>0 0 1 8</b>	Sin/cos absolute value encoder (Hiperface) and incremental encoder (TTL, HTL)			
	<b>0 0 2 1</b>	Sin/cos absolute value encoder (EnDat)			
	<b>0 0 2 3</b>	Incremental encoder IK4096-5V-T (Renco R35i)			
Trailing cable	<b>0 0 2 0</b>	Resolver		<b>A 0 0</b> Without plug-in connector	<b>A 0 0</b> Without plug-in connector
	<b>0 0 1 9</b>	Sin/cos absolute value encoder (Hiperface) and incremental encoder (TTL, HTL)			
	<b>0 0 2 2</b>	Sin/cos absolute value encoder (EnDat)			
	<b>0 0 2 4</b>	Incremental encoder IK4096-5V-T (Renco R35i)			
	<b>0 0 4 8</b>	Incremental encoder (HTL)			





### Blower connecting cables

Product series	Cable type	Connection cable	Cable length in decimetres	Cable end on the motor side (socket)	Cable end (control cabinet)	For use with
E Y		A				
L			0 0 0 3 5 0 0 0			
Blower						
-----						
Fixed installation	0 0 0 1			L 0 1 Screw plug L 0 3 SpeedTec	A 0 0 Without plug-in connector	MDFKS
-----						
				L 0 2 Screw plug L 0 4 SpeedTec	A 0 0 Without plug-in connector	MCA, MCS, MDFMA
-----						
				L 0 5 Screw plug L 0 6 SpeedTec	A 0 0 Without plug-in connector	MDFMA
-----						
Trailing cable	0 0 0 2			L 0 1 Screw plug L 0 3 SpeedTec	A 0 0 Without plug-in connector	MDFKS
-----						
				L 0 2 Screw plug L 0 4 SpeedTec	A 0 0 Without plug-in connector	MCA, MCS, MDFMA
-----						
				L 0 5 Screw plug L 0 6 SpeedTec	A 0 0 Without plug-in connector	MDFMA

## Blower connecting cables

Product series	Cable type	Cable without plug-in connector	Cable length in decimetres	Cable end on the motor side	Cable end (control cabinet)
E Y L Blower		Y	0 0 0 3 5 0 0 0 Minimum length Maximum length		
Fixed installation	0 0 0 1			A 0 0 Without plug-in connector	A 0 0 Without plug-in connector
Trailing cable	0 0 0 2			A 0 0 Without plug-in connector	A 0 0 Without plug-in connector

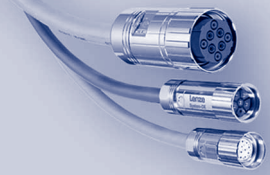

### Motor extensions

Product series	Cable type	Extension cable	Cable length in decimetres	Cable end on the motor side (socket)	Cable end on the controller side (pin)
<b>E Y</b> P Motor		<b>V</b>	<b>0 0 0 3</b> <b>5 0 0 0</b> Minimum length Maximum length		
Fixed installation	<b>0 0 0 3</b> <b>0 0 0 4</b> <b>0 0 0 5</b>	1.0 mm <sup>2</sup> 1.5 mm <sup>2</sup> 2.5 mm <sup>2</sup>		<b>M 0 1</b> Screw plug <b>M 0 4</b> SpeedTec <b>A 0 0</b> Without plug-in connector	<b>P 0 4</b> SpeedTec
	<b>0 0 0 5</b> <b>0 0 0 6</b>	2.5 mm <sup>2</sup> 4.0 mm <sup>2</sup>		<b>M 0 2</b> Screw plug <b>M 0 5</b> SpeedTec <b>A 0 0</b> Without plug-in connector	<b>P 0 5</b> SpeedTec
	<b>0 0 0 7</b> <b>0 0 0 8</b> <b>0 0 0 9</b>	6.0 mm <sup>2</sup> 10.0 mm <sup>2</sup> 16.0 mm <sup>2</sup>		<b>M 0 3</b> Screw plug <b>M 0 6</b> SpeedTec <b>A 0 0</b> Without plug-in connector	<b>P 0 6</b> SpeedTec
Trailing cable	<b>0 0 1 0</b> <b>0 0 1 1</b> <b>0 0 1 2</b>	1.0 mm <sup>2</sup> 1.5 mm <sup>2</sup> 2.5 mm <sup>2</sup>		<b>M 0 1</b> Screw plug <b>M 0 4</b> SpeedTec <b>A 0 0</b> Without plug-in connector	<b>P 0 4</b> SpeedTec
	<b>0 0 1 2</b> <b>0 0 1 3</b>	2.5 mm <sup>2</sup> 4.0 mm <sup>2</sup>		<b>M 0 2</b> Screw plug <b>M 0 5</b> SpeedTec <b>A 0 0</b> Without plug-in connector	<b>P 0 5</b> SpeedTec
	<b>0 0 1 4</b> <b>0 0 1 5</b> <b>0 0 1 6</b>	6.0 mm <sup>2</sup> 10.0 mm <sup>2</sup> 16.0 mm <sup>2</sup>		<b>M 0 3</b> Screw plug <b>M 0 6</b> SpeedTec <b>A 0 0</b> Without plug-in connector	<b>P 0 6</b> SpeedTec

### Feedback extensions

Product series	Cable type	Extension cable	Cable length in decimetres	Cable end on the motor side (socket)	Cable end on the controller side (pin)
E Y		V			
F			0 0 0 3 5 0 0 0		
Feedback			Minimum length Maximum length		
Fixed installation	0 0 1 7	Resolver		F 0 1 Screw plug F 0 5 SpeedTec A 0 0 Without plug-in connector	G 0 6 SpeedTec
	0 0 2 1	Sin/cos absolute value encoder (EnDat)		F 0 3 Screw plug F 0 7 SpeedTec A 0 0 Without plug-in connector	G 0 8 SpeedTec
Trailing cable	0 0 2 0	Resolver		F 0 1 Screw plug F 0 5 SpeedTec A 0 0 Without plug-in connector	G 0 6 SpeedTec
	0 0 2 2	Sin/cos absolute value encoder (EnDat)		F 0 3 Screw plug F 0 7 SpeedTec A 0 0 Without plug-in connector	G 0 8 SpeedTec

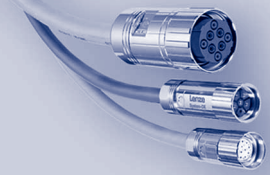

### Feedback extensions

Product series	Cable type	Extension cable	Cable length in decimetres	Cable end on the motor side (socket)	Cable end on the controller side (pin)
<b>E Y</b> Feedback		<b>V</b>	<b>0 0 0 3</b> Minimum length <b>5 0 0 0</b> Maximum length		
Fixed installation	<b>0 0 1 8</b>	Sin/cos absolute value encoder (Hiperface) and incremental encoder (TTL, HTL)		<b>F 0 2</b> Screw plug <b>F 0 6</b> SpeedTec <b>A 0 0</b> Without plug-in connector	<b>G 0 7</b> SpeedTec
	<b>0 0 2 3</b>	Incremental encoder IK4096-5V-T (Renco R35i)		<b>F 0 4</b> Screw plug <b>F 0 8</b> SpeedTec <b>A 0 0</b> Without plug-in connector	<b>G 0 9</b> SpeedTec
Trailing cable	<b>0 0 1 9</b>	Sin/cos absolute value encoder (Hiperface) and incremental encoder (TTL, HTL)		<b>F 0 2</b> Screw plug <b>F 0 6</b> SpeedTec <b>A 0 0</b> Without plug-in connector	<b>G 0 7</b> SpeedTec
	<b>0 0 2 4</b>	Incremental encoder IK4096-5V-T (Renco R35i)		<b>F 0 4</b> Screw plug <b>F 0 8</b> SpeedTec <b>A 0 0</b> Without plug-in connector	<b>G 0 9</b> SpeedTec
	<b>0 0 4 8</b>	Incremental encoder (HTL)		<b>D 0 1</b> M12-A socket <b>A 0 0</b> Without plug-in connector	<b>G 0 7</b> SpeedTec

### Blower extensions

Product series	Cable type	Extension cable	Cable length in decimetres	Cable end on the motor side (socket)	Cable end (pin)	For use with
E Y		V	0 0 0 3 5 0 0 0			
L			Minimum length Maximum length			
Blower						
Fixed installation	0 0 0 1			L 0 1 Screw plug L 0 3 SpeedTec A 0 0 Without plug-in connector	J 0 3 SpeedTec	MDFKS
				L 0 2 Screw plug L 0 4 SpeedTec A 0 0 Without plug-in connector	J 0 4 SpeedTec	MCA, MCS, MDFMA
				L 0 5 Screw plug L 0 6 SpeedTec A 0 0 Without plug-in connector	J 0 5 SpeedTec	MDFMA
Trailing cable	0 0 0 2			L 0 1 Screw plug L 0 3 SpeedTec A 0 0 Without plug-in connector	J 0 3 SpeedTec	MDFKS
				L 0 2 Screw plug L 0 4 SpeedTec A 0 0 Without plug-in connector	J 0 4 SpeedTec	MCA, MCS, MDFMA
				L 0 5 Screw plug L 0 6 SpeedTec A 0 0 Without plug-in connector	J 0 5 SpeedTec	MDFMA

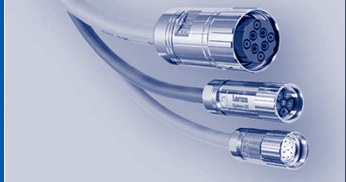

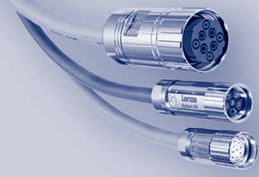

## System cables

Product key



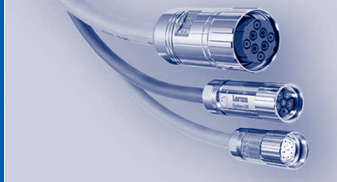



**Lenze SE**  
 Postfach 10 13 52  
 D-31763 Hameln  
 Telefon +49 (0)51 54 / 82-0  
 Telefax +49 (0)51 54 / 82-28 00  
 E-Mail: Lenze@Lenze.de  
 Internet: www.Lenze.com

**Lenze Automation GmbH**  
 Grünstraße 36, D-40667 Meerbusch  
 Telefon +49 (0)21 32 / 99 04-0  
 Telefax +49 (0)21 32 / 7 21 90  
 Standort:  
 Hans-Lenze-Straße 1, D-31855 Aerzen  
 Postfach 101352, D-31763 Hameln  
 Telefon +49 (0)51 54 / 82-0  
 Telefax +49 (0)51 54 / 82-28 00

**Standort:**  
 Am Alten Bahnhof 11  
 D-38122 Braunschweig  
 Telefon +49 (0)531 / 80178-0  
 Telefax +49 (0)531 / 80178-20

**Lenze Drives GmbH**  
 Postfach 10 13 52, D-31763 Hameln  
 Breslauer Strasse 3, D-31855 Aerzen  
 Telefon +49 (0)51 54 / 82-0  
 Telefax +49 (0)51 54 / 82-28 00

**Lenze Operations GmbH**  
 Postfach 10 13 52, D-31763 Hameln  
 Hans Lenze Straße 1, D-31855 Aerzen  
 Telefon +49 (0)51 54 / 82-0  
 Telefax +49 (0)51 54 / 82-28 00

**Lenze GmbH & Co KG Anlagenbau**  
 Buchenweg 1  
 D-31855 Aerzen  
 Telefon +49 (0)51 54 / 82-0  
 Telefax +49 (0)51 54 / 82-21 00

**Lenze Service GmbH**  
 Breslauer Straße 3  
 D-32699 Extertal  
**Mechanical Drives**  
 Telefon +49 (0)51 54 / 82-16 26  
 Telefax +49 (0)51 54 / 82-13 96  
**Electronic Drives**  
 Telefon +49 (0)51 54 / 82-11 11  
 Telefax +49 (0)51 54 / 82-11 12

**Service Helpline**  
 +49 (0)180 5 20 24 26

**Lenze Verbindungstechnik GmbH**  
 Ipf-Landesstraße 1  
 A-4481 ASTEN  
 Telefon +43 (0)72 24 / 210-0  
 Telefax +43 (0)72 24 / 210-998

**Lenze DETO Drive Systems GmbH & Co KG**  
 Untere Sparchen 16  
 A-6330 Kufstein  
 Telefon +43 (0)53 72 / 6 53 15-200  
 Telefax +43 (0)53 72 / 6 53 15-299

**Schmidhauser AG**  
 Obere Neustrasse 1  
 CH-8590 Romanshorn  
 Telefon +41 (0)71 466 11 11  
 Telefax +41 (0)71 466 11 10

**encoway GmbH**  
 Buschhöhe 2  
 D-28357 Bremen  
 Telefon +49 (0)4 21 / 33003 - 500  
 Telefax +49 (0)4 21 / 33003 - 555

## DEUTSCHLAND/GERMANY

**Lenze Vertrieb GmbH \***  
 Ludwig-Erhard-Straße 52-56  
 D-72760 Reutlingen  
 Telefon +49 (0)71 21 / 9 39 39-0  
 Telefax +49 (0)71 21 / 9 39 39-29

**Region Nord**  
 HefeHof 25  
 31785 Hameln  
 Telefon (0 51 54) 82 44-0  
 Telefax (0 51 54) 82 44-44

**Region West**  
 Postfach 10 12 20  
 47497 Neukirchen-Vluyn  
 Kelvinstraße 7  
 47506 Neukirchen-Vluyn  
 Telefon (0 28 45) 95 93-0  
 Telefax (0 28 45) 95 93 93

**Region Mitte/Ost**  
 Postfach 1463  
 35724 Herborn  
 Austraße 81  
 35745 Herborn  
 Telefon (0 27 72) 95 94-0  
 Telefax (0 27 72) 95 94 94

**Region Südwest**  
 Postfach 14 33  
 71304 Waiblingen  
 Schänzle 8  
 71332 Waiblingen  
 Telefon (0 71 51) 9 59 81-0  
 Telefax (0 71 51) 9 59 81 50

**Region Süd**  
 Fraunhoferstraße 16  
 82152 Martinsried  
 Telefon (0 89) 89 56 14-0  
 Telefax (0 89) 89 56 14 14

## WELTWEIT/WORLDWIDE

**ALGERIA**  
 see FRANCE

**ARGENTINA \***  
 E.R.H.S.A.  
 Girardot 1368, 1427 BUENOS AIRES  
 Phone +54 (0)11 / 45 54 32 32  
 Telefax +54 (0)11 / 45 52 36 11

**AUSTRALIA \***  
 FCR Motion Technology Pty. Ltd.  
 Unit 6, Automation Place  
 38-40 Little Boundary Rd.  
 LAVERTON NORTH, Vic. 3026  
 Phone +61 (3) 9362 6800  
 Telefax +61 (3) 9314 3744

**AUSTRIA \***  
 Lenze Antriebstechnik GmbH  
 Ipf-Landesstraße 1  
 4481 ASTEN  
 Phone +43 (0)7224 / 210-0  
 Telefax +43 (0)7224 / 210-999  
 Office Dornbirn:  
 Lustenauer Straße 64  
 6850 DORNBRN  
 Phone +43 (0)7224 / 210-0  
 Telefax +43 (0)7224 / 210-7299

**Office Wr. Neudorf:**  
 Triester Straße 14/109  
 2351 WR. NEUDORF  
 Phone +43 (0)7224 / 210-0  
 Telefax +43 (0)7224 / 210-7099

**Office Graz:**  
 Seering 8  
 8141 UNTERPREMSTÄTTEN  
 Phone +43 (0)7224 / 210-0  
 Telefax +43 (0)7224 / 210-7199

**Lenze Verbindungstechnik GmbH**  
 Ipf-Landesstraße 1  
 4481 ASTEN  
 Phone +43 (0)7224 / 210-0  
 Telefax +43 (0)7224 / 210-998

**Lenze Anlagentechnik GmbH**  
 Mühlenstraße 3  
 4470 ENNS  
 Phone +43 (0)7224 / 210-0  
 Telefax +43 (0)7224 / 210-997

**BELARUS**  
 see POLAND

**BELGIUM \***  
 Lenze bv.ba  
 Industriepark Noord, 19.  
 9100 SINT-NIKLAAS  
 Phone +32 (0)3.542.62.00  
 Telefax +32 (0)3.541.37.54

**BOSNIA-HERZEGOVINA**  
 see AUSTRIA

**BRAZIL \***  
**Lenze Brasil Automação Ltda.**  
 Rua Conde Moreira Lima 589  
 CEP 04384-030  
 SÃO PAULO/SP – Brasil  
 Phone +55 11 2348-6579  
 Telefax +55 11 2348-6573

**Produtos Eletrônicos MetalteX Ltda**  
**(Focus on Sales)**  
 Rua José Rafaelli, 221  
 Socorro, CEP 04763-280  
 SÃO PAULO/SP – Brasil  
 Phone +55 11 56 83 57 00  
 Telefax +55 11 55 24 23 24

**BULGARIA**  
 Lenze Zadvizhvasta Tehnika EOOD  
 Bul. Maritza 21, Office 204  
 4003 PLOVDIV  
 Phone +359 / 32 / 940 373  
 Telefax +359 / 32 / 940 349

**CANADA \***  
**Lenze Canada Corporation**  
 1535 Meyerside Drive, Unit 1  
 Mississauga, ON L5T 1M9 CANADA  
 Phone +1 (508) 278-9100  
 Telefax +1 (508) 278-7873

**CENTRAL AMERICA**  
 see Americas HQ

**CHILE**  
 Sargent S.A.  
 Tecnica Thomas C. Sargent  
 Av. Gral. Velásquez 5720, San Bernardo  
 SANTIAGO – CHILE  
 Phone +56 (0)2 / 51 03 000  
 Telefax +56 (0)2 / 69 83 989

**CHINA \***  
 Lenze Drive Systems (Shanghai) Co. Ltd.  
 No. 2989, Jiangshan Road  
 Lingang, Shanghai 201306  
 CHINA  
 Phone +86 21 3828 0200  
 Telefax +86 21 3828 0250

**COLOMBIA**  
 Casa Sueca, S.A.  
 Calle 52 1N-74  
 CALI  
 Phone +57 -2- 682 0444  
 Telefax +57 -2- 683 1411

**CROATIA**  
 Lenze mehatronika-pogonska tehnika  
 d.o.o.  
 Ulica grada Gospića 3  
 HR-10000 ZAGREB  
 Phone +385 1 249-8056  
 Telefax +385 1 249-8057

**CZECH REPUBLIC**  
 Lenze, s.r.o.  
 Central Trade Park D1  
 396 01 HUMPOLEC  
 Phone +420 565 507-111  
 Telefax +420 565 507-399

**Büro Červený Kostelec:**  
 17. listopadu 510  
 549 41 ČERVENÝ KOSTELEČ  
 Phone +420 491 467-111  
 Telefax +420 491 467-166

**DENMARK \***  
 Lenze A/S  
 Vallensbækvej 18A  
 2605 BRØNDBY  
 Phone +45 / 4696 6666  
 Telefax +45 / 4696 6660  
 24 stunde service +45 / 5251 6699

**Buero Jylland: Lenze A/S**  
 Niels Bohrs Vej 23  
 8660 SKANDERBORG  
 Phone +45 / 46 96 66 88  
 Telefax +45 / 46 96 66 80

**EGYPT**  
 WADI Co. for technologies  
 and development  
 P.O.Box 209, new center Ramses  
 11794 CAIRO, Egypt  
 11 Syria St., Mohandessin  
 GIZA, Egypt  
 Phone +2 (02) 3347 6842  
 Telefax +2 (02) 3347 6843

**ESTONIA**  
 see FINLAND

**FINLAND \***  
 Lenze Drives  
 Tierankatu 8, 20520 TURKU  
 Phone +358 2 2748 180  
 Telefax +358 2 2748 189

**FRANCE \***  
 Lenze S.A.  
**Siège**  
 21 des Mardelles  
 44 Rue Blaise Pascal  
 93600 AULNAY-SOUS-BOIS

**Services Commerciaux**  
 Phone 0 825 086 036  
 Telefax 0 825 086 346

**Centre de formation**  
 E-Mail : semin.sidonie@lenze.fr

**Questions générales / documentation**  
 E-Mail : info@lenze.fr

**Service Après-vente / assistance en ligne**  
 Helpline 24/24 : 0 825 826 117  
 E-Mail : helpline@lenze.fr

**Agences en France**  
**Région France Nord :**  
 21 des Mardelles  
 44 Rue Blaise Pascal  
 93600 AULNAY-SOUS-BOIS

**Nantes**  
 44000 NANTES  
**Strasbourg**  
 67870 GRIÈSHEIM près MOLSHEIM  
**Rouen**  
 76500 ELBEUF

**Région France Sud :**  
 Parc Technologique  
 97, allée Alexandre Borodine  
 Immeuble le Douglas 2  
 69800 SAINT PRIEST

**Agen**  
 47270 SAINT-PIERRE de CLAIRAC

**GREECE**  
 GEORGE P. ALEXANDRIS SA  
 12, K. Mavromichali Street  
 18545 PIRAEUS  
 Phone +30 210 41 11 841  
 Telefax +30 210 41 27 058

**Industrial Area, Block 48B, 4th Entrance**  
 57022 SINDOS  
 Phone +30 2310 556 650  
 Telefax +30 2310 511 815

**HUNGARY \***  
 Lenze Hajtástechnika Kft  
 2040 BUDAÖRS  
 Gyár utca 2., P.O.Box 322.  
 Phone +36 (0)23 / 501-320  
 Telefax +36 (0)23 / 501-339

**ICELAND**  
 see DENMARK



## INDIA

Lenze Mechatronics Pvt. Ltd.  
Lenze Plot No. 46A, Sector-10  
PCNTDA Industrial Area, Bhosari  
PUNE - 411 026  
Phone +91-20-66318100  
Telefax +91-20-66318120

Kolkata Sales office  
2nd Floor, 3/1 Ashton Road  
KOLKATA - 700020  
Phone +91-33-24190490  
Telefax +91-33-24190562

New Delhi Sales office  
Flat No - 101, Padma Tower - II  
22, Rajendra Place  
NEW DELHI - 110008  
Phone +91-11-25812113/15  
Telefax +91-11-25812114

## INDONESIA

see MALAYSIA

## IRAN

Tavan Ressian Co.  
P.O.Box 19395-5177  
No. 18, Sh. Bakhtiary Str.  
South sh. Ghalandari Ave.  
Sadr High way, TEHRAN  
Phone +98-(21)-2260 6766  
-2260 2655  
-2260 9299  
Telefax +98-(21)-2200 2883

## ISRAEL \*

Zeev Melcer LTD  
P.O.B. 10011, HAIFA BAY 26110  
36 Yosef Levi St., Kiriati Bialik  
Phone +972-(0)4-8757037  
Telefax +972-(0)4-8742172

## ITALY \*

Lenze Italia S.r.l.  
Viale Monza 338, 20128 MILANO  
Phone +39 02 / 270 98.1  
Telefax +39 02 / 270 98 290

## JAPAN \*

Miki Pulley Co., Ltd.  
1-39-7 Komatsubara, Zama-city  
KANAGAWA 228-8577  
Phone +81 (0)462 / 58 16 61  
Telefax +81 (0)462 / 58 17 04

## LATVIA

see LITHUANIA

## LEBANON

I. Network Automation s.a.l.  
Ground floor - United insurance building  
Facing Mercedes Show room  
Dora - High Way, BEIRUT-METEN  
P.O.Box 835 - Jounieh - Lebanon  
Phone +961-1-249562  
Telefax +961-1-249563

## LITHUANIA

Lenze UAB  
Breslaujos g.3, 44403 KAUNAS  
Phone +370 37 407174  
Telefax +370 37 407175

## LUXEMBOURG \*

see BELGIUM

## MACEDONIA

Lenze Antriebstechnik GmbH  
Pretstavnstvo Skopje  
ul. Nikola Rusinski 3/A/2, 1000 SKOPJE  
Phone +389 2 30 90 090  
Telefax +389 2 30 90 091

## MALAYSIA

Lenze S.E.A. Sdn Bhd  
No. 28 Jalan PJU 3/47  
Sunway Damansara, Technology Park  
47810 PETALING JAYA  
SELANGOR DARUL EHSAN  
Phone +60 3 7803 1428  
Telefax +60 3 7806 3728

## MAURITIUS

Automation & Controls Engineering Ltd  
3, Royal Road, Le Hochet, Terre Rouge  
MAURITIUS  
Phone +230 248 8211  
Telefax +230 248 8968

## MEXICO

Sales:  
see AMERICAS HQ

Service:  
**Automatización y Control  
de Energía S.A. de C.V.**  
Av. 2 No.89 Esq Calle 13  
Col. San Pedro de los Pinos  
C.P. 03800 MEXICO D.F.  
Phone +52 55 2636-3540  
Fax +52 55 2636-3541

## MOROCCO

GUORFET G.T.D.R  
Automatisation Industrielle  
Bd Chefchaouni Route 110 km, 11.500  
No. 353-Ain-Sabaâ  
CASABLANCA  
Phone +212/22-35 70 78  
Telefax +212/22-35 71 04

## NETHERLANDS \*

Lenze B.V., Postbus 31 01  
5203 DC 'S-HERTOGENBOSCH  
Ploegweg 15  
5232 BR 'S-HERTOGENBOSCH  
Phone +31 (0)73 / 64 56 50 0  
Telefax +31 (0)73 / 64 56 51 0

## NEW ZEALAND \*

Tranz Corporation  
343 Church Street  
P.O. Box 12-320, Penrose  
AUCKLAND  
Phone +64 (0)9 / 63 45 51 1  
Telefax +64 (0)9 / 63 45 51 8

## NORWAY \*

Dtc- Lenze as  
Stallbakken 5, 2005 RAEILINGEN  
Phone +47 / 64 80 25 10  
Telefax +47 / 64 80 25 11

## PHILIPPINES

see MALAYSIA

## POLAND

Lenze Polska Sp. z o.o.  
Ul. Rożdżeńskiego 188b  
40-203 KATOWICE  
Phone +48 (0) 32 203 97 73  
Telefax +48 (0) 32 781 01 80

Torun Office  
Lenze Polska Sp. z o.o.  
Ul. Rydygiera 47  
87-100 TORUN  
Phone +48 (0) 56 658 28 00  
Telefax +48 (0) 56 645 33 56

## PORTUGAL \*

Costa Leal el Victor  
Electronica-Pneumatica, Lda.  
Rua Prof. Augusto Lessa, 269,  
Apart. 52053  
4202-801 PORTO  
Phone +351-22 / 5 50 85 20  
Telefax +351-22 / 5 02 40 05

## ROMANIA

see AUSTRIA

## RUSSIA

OOO Lenze  
Shchelkovskoye shosse 5  
105122 MOSCOW  
Phone +7 495 921 3250  
Telefax +7 495 921 3259

## SERBIA-MONTENEGRO

see MACEDONIA

## SINGAPORE \*

see MALAYSIA

## SLOVAC REPUBLIC

ECS Sluzby spol. s.r.o.  
Staromlynska 29  
82106 BRATISLAVA  
Phone +421 2 45 25 96 06  
+421 2 45 64 31 47  
+421 2 45 64 31 48  
Telefax +421 2 45 25 96 06

## SLOVENIA

LENZE GmbH, Asten, Avstrija  
Podružnica Celje  
Kidričeva 24  
3000 CELJE  
Phone +386 03 426 46 40  
Telefax +386 03 426 46 50

## SOUTH AFRICA \*

S.A. Power Services (Pty.) Ltd.  
Unit 14, Meadowbrook Business Estates  
Jacaranda Ave, Olivedale  
Randburg 2158, P.O.Box 1137  
RANDBURG 2125  
Phone +27(11) 462-8810  
Telefax +27(11) 704-5775

## SOUTH KOREA \*

Lenze Representative Office  
No. 606, Daeryung Technotown 6th,  
493-6, Gasan-dong, Geumcheon-gu,  
SEOUL 153-774  
Phone +82 2-792-7017  
Telefax +82 2-792-7018

## SPAIN \*

Lenze Transmisiones, S.A. (Headquarter)  
Edificio TCA  
Henri Dunant, 9. Planta baja  
08173 SANT CUGAT DEL VALLES  
Barcelona  
Phone +34 902 02 79 04  
Telefax +34 902 02 63 69

Lenze Delegación Norte  
Phone +34 944 630 510 / 507  
Telefax +34 944 314 196

Lenze Delegación Levante  
Cullera, 73 - 4ºD  
46035 BENIMAMET  
Valencia  
Phone +34 963 905 225  
Telefax +34 963 900 647  
Lenze Delegación Madrid  
Poema Sinfónico Nº 25-27  
Esc. 1, Pfta. B, Loc. 3  
28054 MADRID  
Phone +34 915 103 341  
Telefax +34 915 102 061

## SWEDEN \*

Lenze Transmissioner AB  
PO.Box 10 74, Attorpsgratan, Tornby Ind.  
58110 LINKÖPING  
Phone +46 (0)13 / 35 58 00  
Telefax +46 (0)13 / 10 36 23

## SWITZERLAND \*

Lenze Bachofen AG  
Ackerstrasse 45  
8610 USTER  
Phone +41 (0) 43 399 14 14  
Telefax +41 (0) 43 399 14 24

Vente Suisse Romande:  
Route de Prilly 25  
1023 CRISSIER  
Phone +41 (0)21 / 63 72 19 0  
Telefax +41 (0)21 / 63 54 76 2

## SYRIA

Zahabi Co.  
8/5 Shouhadadaa Street  
P.O.Box 8262  
ALEPPO-SYRIA  
Phone +963 21 21 22 23 5  
Telefax +963 21 21 22 23 7

## TAIWAN \*

Lenze Taiwan Representative Office  
6F-1, No.136, Sec. 3, Zhongxiao E. Rd.  
TAIPEI City, 10655, Taiwan  
Phone +886 / (0)2-2721-2161  
Telefax +886 / (0)2-2721-2706

## THAILAND

see MALAYSIA

## TUNESIA

AMF Industrielle Sarl  
Route de Gremda - Km 0,2  
Immeuble El Madina,  
Centre Bloc B - 5 ème - appt 52  
3002 SFAX  
Phone +216 74 403 514  
Telefax +216 74 402 516

## TURKEY

LSE Elektrik  
Elektronik Makina  
Otomasyon Mühendislik  
Sanayi ve Ticaret Ltd. Şti  
Atatürk mah. Cumhuriyet cad.  
Yurt sok. No: 7  
ÜMRANIYE/İSTANBUL  
Phone +90 (0)216 / 316 5138 pbx  
Telefax +90 (0)216 / 443 4277

## UKRAINE

SV Altera, Ltd.  
Lepse ave., 4  
KIEV, 03067  
Phone +38 044 496 18 88  
Telefax +38 044 496 18-18

## UNITED ARAB EMIRATES

LPT (FZC)  
X4 Building No. 37  
Sharjah Airport Free Zone (SALF ZONE)  
SHARJAH  
Phone +971 6 5573205  
Telefax +971 6 5573206

## UNITED KINGDOM/EIRE \*

Lenze Ltd.  
Fraser Road  
Priory Business Park  
BEDFORD MK44 3WH  
Phone +44 (0)1234 / 75 32 00  
Telefax +44 (0)1234 / 75 32 20

## USA \*

AMERICAS HQ  
Lenze Americas Corporation  
630 Douglas Street  
UXBRIDGE, MA 01569  
Phone +1 508 278 9100  
Telefax +1 508 278 7873

Sales:  
see Americas HQ

Operations:  
Lenze AC Tech Corporation  
630 Douglas Street  
UXBRIDGE, MA 01569  
Phone +1 508 278 9100  
Telefax +1 508 278 9294

Lenze DETO Drive Systems  
see Americas HQ

## VIETNAM

see MALAYSIA

\* Countries connected to the free expert helpline 008000 24 hours (008000 24 46877)

# It's good to know | why we are there for you



*"Our customers come first. Customer satisfaction is what motivates us. By thinking in terms of how we can add value for our customers we can increase productivity through reliability."*



*"We will provide you with exactly what you need – perfectly co-ordinated products and solutions with the right functions for your machines and installations. That is what we mean by 'quality'."*



*"Take advantage of our wealth of expertise. For more than 60 years now we have been gathering experience in various fields and implementing it consistently and rigorously in our products, motion functions and pre-configured solutions for industry."*



*"The world is our marketplace. Wherever you are in the world, we are nearby, providing you with our drive and automation solutions."*

Algeria · Argentina · Australia · Austria · Belarus · Belgium · Bosnia-Herzegovina · Brazil · Bulgaria · Canada · Central America · Chile · China · Colombia · Croatia · Czech Republic · Denmark · Egypt · Estonia · Finland · France · Germany · Greece · Hungary · Iceland · India · Indonesia · Iran · Israel · Italy · Japan · Latvia · Lebanon · Lithuania · Luxembourg · Macedonia · Malaysia · Mauritius · Mexico · Morocco · Netherlands · New Zealand · Norway · Philippines · Poland · Portugal · Romania · Russia · Serbia-Montenegro · Singapore · Slovak Republic · Slovenia · South Africa · South Korea · Spain · Sweden · Switzerland · Syria · Taiwan · Thailand · Tunisia · Turkey · Ukraine · United Arab Emirates · United Kingdom/Eire · USA · Vietnam

**You can rely on our service. Expert advice is available 24 hours a day, 365 days a year, in more than 30 countries via our international helpline: 008000 24 Hours (008000 2446877).**

[www.Lenze.com](http://www.Lenze.com)

13358173