



User Guide

Midi-Maestro Maxi-Maestro

Variable Speed Drives
for permanent-magnet DC servo-motors
1kW, 2kW and 5 kW

Part Number: 0437-0006-04

Issue Number: 4

www.controltechniques.com

General Information

The manufacturer accepts no liability for any consequences resulting from inappropriate, negligent or incorrect installation or adjustment of the optional operating parameters of the equipment or from mismatching the variable speed drive (Drive) with the motor.

The contents of this guide are believed to be correct at the time of printing. In the interests of a commitment to a policy of continuous development and improvement, the manufacturer reserves the right to change the specification of the product or its performance, or the contents of this guide, without notice.

All rights reserved. No parts of this guide may be reproduced or transmitted in any form or by any means, electrical or mechanical including photocopying, recording or by an information storage or retrieval system, without permission in writing from the publisher.

Contents

| | | |
|----------|---|-----------|
| 1 | Safety Information | 1 |
| 1.1 | Warnings, Cautions and Notes | 1 |
| 1.2 | Electrical safety – general warning | 1 |
| 1.3 | System design | 1 |
| 1.4 | Environmental limits | 1 |
| 1.5 | Compliance with regulations | 1 |
| 1.6 | Safety of personnel | 2 |
| 1.7 | Risk analysis | 2 |
| 1.8 | Isolation of control circuits–Maestro range of servo drives | 2 |
| 2 | Product Information | 3 |
| 2.1 | Features | 3 |
| 2.2 | Data | 3 |
| 3 | Mechanical Installation | 8 |
| 3.1 | Mounting location | 8 |
| 3.2 | Choke (optional) | 11 |
| 3.3 | Braking resistor | 12 |
| 3.4 | Ventilation | 13 |
| 4 | Electrical Installation | 14 |
| 4.1 | Power connector | 16 |
| 4.2 | Transformer power rating | 17 |
| 4.3 | Supply fuses | 19 |
| 4.4 | DC bus voltage | 19 |
| 4.5 | Ground connections | 20 |
| 4.6 | Motor connections | 20 |
| 4.7 | When to use a braking resistor | 24 |
| 4.8 | Braking resistor connections | 27 |
| 4.9 | Braking resistor calculations | 29 |
| 4.10 | Signal connections | 34 |
| 5 | Optimisation | 35 |
| 5.1 | Setting up the drive | 35 |
| 5.2 | Potentiometers | 35 |
| 5.3 | Switches | 36 |
| 5.4 | Mounted components | 37 |
| 5.5 | Making adjustments to the Midi-Maestro drive | 38 |
| 5.6 | Making adjustments to the Maxi-Maestro drive | 47 |
| 5.7 | Commissioning | 54 |

| | | |
|----------|-----------------------------------|-----------|
| 6 | Diagnostics | 56 |
| 6.1 | LED indicators | 56 |
| 6.2 | Outputs | 57 |
| 6.3 | Fault finding | 57 |
| 7 | Miscellaneous | 59 |
| 7.1 | Alternative daughter boards | 59 |
| | Index | 61 |

Declaration of Conformity

Control Techniques PLC
The Gro
Newtown
Powys
UK
SY16 3BE

| | |
|-----------------|-------------|
| Midi Maestro | 140 x 8/16 |
| Midi Maestro | 140 x 14/28 |
| Maxi Maestro | 200 x 25/50 |
| Maxi Maestro LV | 100 x 25/50 |

The above servo drive products have been designed and manufactured in accordance with the following European harmonised, national and international standards:

| | |
|----------|---|
| EN60249 | Base materials for printed circuits |
| IEC326-1 | Printed boards: General information for the specification writer |
| IEC326-5 | Printed boards: for single and double sided printed boards with plated through holes |
| IEC326-6 | Printed boards: Specification for multilayer printed boards |
| IEC664-1 | Insulation co-ordination for equipment within low-voltage systems: Principles, requirements and tests |
| EN60529 | Degrees of protection provided by enclosures (IP code) |
| UL94 | Flammability rating of plastic materials |

This product complies with the Low Voltage Directive 73/23/EEC and the CE Marking Directive 93/68/EEC.



W. Drury
Technical Director
Newtown
Date: 7 April 1999

This electronic drive product is intended to be used with an appropriate motor, controller, electrical protection components and other equipment to form a complete end product or system. It must only be installed by a professional assembler who is familiar with requirements for safety and electromagnetic compatibility (EMC). The assembler is responsible for ensuring that the end product or system complies with all the relevant laws in the country where it is to be used. Refer to the product manual or EMC data sheet for further information on EMC standards complied with by the product, and guidelines for installation.

1 Safety Information

1.1 Warnings, Cautions and Notes



A **Warning** contains information, which is essential for avoiding a safety hazard.



A **Caution** contains information, which is necessary for avoiding a risk of damage to the product or other equipment.

NOTE

A **Note** contains information, which helps to ensure correct operation of the product.

1.2 Electrical safety – general warning

The voltages used in the drive can cause severe electric shock and/or burns, and could be lethal. Extreme care is necessary at all times when working with or adjacent to the drive.

Specific warnings are given at the relevant places in this User Guide.

The installation must comply with all relevant safety legislation in the country of use.

The drive contains capacitors that remain charged to a potentially lethal voltage after the AC supply has been disconnected. If the drive has been energised, the AC supply must be isolated *at least ten minutes* before work may continue.

1.3 System design

The drive is intended as a component for professional incorporation into complete equipment or systems. If installed incorrectly the drive may present a safety hazard. The drive uses high voltages and currents, carries a high level of stored electrical energy, and is used to control mechanical equipment, which can cause injury.

Close attention is required to the electrical installation and the system-design to avoid hazards either in normal operation or in the event of equipment malfunction. Personnel who have the necessary training and experience must carry out system-design, installation, commissioning and maintenance. They must read this safety information and this User Guide carefully.

To ensure mechanical safety, additional safety devices such as Electromechanical interlocks may be required. The drive must not be used in a safety-critical application without additional high-integrity protection against hazards arising from a malfunction.

1.4 Environmental limits

Instructions regarding transport, storage, installation and use of drives must be complied with, including the specified environmental limits. Drives must not be subjected to excessive physical force.

1.5 Compliance with regulations

The installer is responsible for complying with all relevant regulations, such as national

wiring regulations, accident prevention regulations and electro magnetic compatibility (EMC) regulations. Particular attention must be given to the cross-sectional areas of conductors, the selection of fuses or other protection, and protective earth (ground) connections.

The *User Guide* contains instructions for achieving compliance with specific EMC standards.

Within the European Union, all machinery in which this product is used must comply with the following directives:

98/37/EC: Safety of Machinery

89/336/EEC: Electromagnetic Compatibility

1.6 Safety of personnel

The STOP function of the drive does not remove dangerous voltages from the output of the drive or from any external option unit.

The Stop and Start controls or electrical inputs of the drive should not be relied upon to ensure safety of personnel. If a safety hazard could exist from unexpected starting of the drive, an interlock that electrically isolates the drive from the AC supply should be installed to prevent the motor being inadvertently started.

Careful consideration must be given to the functions of the drive, which might result in a hazard, either through their intended functions (e.g. Auto-start) or through incorrect operation due to a fault or trip (e.g. stop/start, forward/reverse, maximum speed).

Under certain conditions, the drive can suddenly discontinue control of the motor. If the load on the motor could cause the motor speed to be increased (e.g. hoists and cranes), a separate method of braking and stopping the motor should be used (e.g. a mechanical brake).

Before connecting the AC supply to the drive, it is important that you understand the operating controls and their operation. If in doubt, do not adjust the drive. Damage may occur, or lives put at risk. Carefully follow the instructions in this User Guide.

Before making adjustments to the drive, ensure all personnel in the area are warned. Make notes of all adjustments that are made.

1.7 Risk analysis

In any application where a malfunction of the drive could lead to damage, loss of life or injury, a risk analysis must be carried out, and where necessary, further measures taken to reduce the risk. This would normally be an appropriate form of independent safety back-up system using simple Electro-mechanical components.

1.8 Isolation of control circuits—Maestro range of servo drives

The control circuits of these drives are not isolated from the power circuits. In most applications an isolating transformer is used to supply the drive, and the negative terminal of the drive DC power circuit is connected to ground. Provided that the ground connection is adequate to carry the prospective fault current of the supply, the control circuits may safely be connected to other grounded circuits. **If the negative DC terminal is not connected to ground then the control circuits must be treated as live at the AC supply potential.**

| | | | | | | |
|--------------------|----------------------------|-------------------------|-------------------------|--------------|-------------|---------------|
| Safety Information | Product Information | Mechanical Installation | Electrical Installation | Optimisation | Diagnostics | Miscellaneous |
|--------------------|----------------------------|-------------------------|-------------------------|--------------|-------------|---------------|

2 Product Information

2.1 Features

2.1.1 Selectable options

Speed control with armature feedback
 Speed control with tachogenerator feedback
 Acceleration and deceleration ramps
 Tachogenerator loss-protection

2.1.2 Adjustments

Full-scale speed
 Current limit
 Dynamic gain
 Derivative action
 Reference speed offset compensation
 Ramp gradient

2.1.3 Diagnostic functions

I²t LED indication
 LED indication of tachogenerator loss
 Drive NORMAL LED indication
 Digital output indicates drive status
 Digital output indicates I²t limit
 Analog output indicates motor current
 Analog output indicates TPRC

2.2 Data

2.2.1 Analog speed reference input

±10V (10kΩ input impedance)

2.2.2 Error amplifier temperature drift

1.3 μV / °C

2.2.3 Tachogenerator feedback control range

1 to 5000 rpm

2.2.4 Minimum tachogenerator signal at maximum speed

5V (To ensure the drive reaches maximum speed with a 10V reference)

2.2.5 Armature feedback control range

150 to 3000 rpm

2.2.6 Ambient temperature

Operating temperature range: -10°C (50°F) to +50°C (122°F)

2.2.7 AC supply

Table 2.1 Minimum supply voltage – three phase

| Midi-Maestro 140x8/16 | Midi-Maestro 140x14/28 | Maxi-Maestro 200x25/50 | Maxi-Maestro 100x25/50 |
|--------------------------|---------------------------|---------------------------|---------------------------|
| 105V | 105V | 150V | 70V |

Tolerance:

Midi-Maestro: +10% -35%

Maxi-Maestro: +20% -35%

Table 2.2 Minimum supply voltage – single phase

| Midi-Maestro 140x8/16 | Midi-Maestro 140x14/28 | Maxi-Maestro 200x25/50 | Maxi-Maestro 100x25/50 |
|--------------------------|---------------------------|---------------------------|---------------------------|
| 105V | | | |

Tolerance:

Midi-Maestro: +10% -35%

When the drive is operated on a single-phase supply, the characteristics of the drive are modified as follows:

I_{NOM} -25%

I_{PEAK} -25%

Voltage to the motor -25%

2.2.8 Power cables

Midi Maestro 2.5 mm² (AWG 14)

Maxi Maestro 4.0 mm² (AWG 10)

2.2.9 Signal wiring

0.5mm² (AWG 20)



The supply terminals are not isolated from the control terminals. The AC supply MUST be isolated.

2.2.10 Output ratings

| Model | Max output voltage | Nominal current | Peak current for 2 seconds |
|---------------------------|--------------------|-----------------|----------------------------|
| Midi-Maestro 140x8/16 | 150Vdc 105Vac | 8A | 16A |
| Midi-Maestro 140x14/28 | 150Vdc 105Vac | 14A | 28A |
| Maxi-Maestro 200x25/50 | 212Vdc 150Vac | 25A | 50A |
| Maxi-Maestro 100x25/50 | 100Vdc 70Vac | 25A | 50A |

2.2.11 Current tolerance

±10%

2.2.12 Braking resistor data

Midi-Maestro

Internal Braking resistor - Fitted as Standard

| Midi-Maestro 140x8/16 | Midi-Maestro 140x14/28 |
|-------------------------------|------------------------|
| 10Ω, 200W Min value = 10Ω* | |

NOTE

* The minimum resistor value has been set to limit the current, through the braking circuit, to protect the drive if a larger rated external braking resistor is required.

Maxi-Maestro

External Braking resistor

When a Maxi-Maestro drive is used, due to the fact that there is no internal braking resistor, an external braking resistor is required. The braking resistor defined as follows is supplied with the drive.

| Maxi-Maestro 200x25/50 | Maxi-Maestro LV 100x25/50 |
|-----------------------------|---------------------------|
| 8Ω, 600W Min value = 8Ω* | |

NOTE

* The minimum resistor value has been set to limit the current, through the braking circuit, to protect the drive if a larger rated external braking resistor is required.

For further information on braking see *Chapter 4 Electrical Installation* on page 4.

2.2.13 Nameplate description - Drive identification

Figure 2-1 Drive rating label

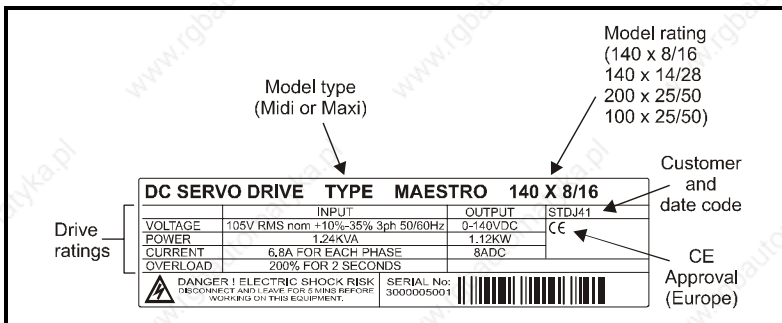

2.2.14 Protection

| Protection | Midi-Maestro 140x8/16 | Midi-Maestro 140x14/28 | Maxi-Maestro 200x25/50 | Maxi-Maestro 100x25/50 |
|-----------------------------------|--------------------------|---------------------------|---------------------------|---------------------------|
| Over-temp limit on heatsink | 95°C | 95°C | 95°C | 95°C |
| Under-voltage limit on the DC bus | 80V | 80V | 100V | 80V |
| Over-voltage limit on the DC bus | 180V | 180V | 275V | 140V |

| | |
|---------------------------|----------------------------------|
| Braking circuit threshold | [AC supply voltage x 1.41] + 18V |
|---------------------------|----------------------------------|

2.2.15 Drive dimensions

Figure 2-2 Dimensions of the drive

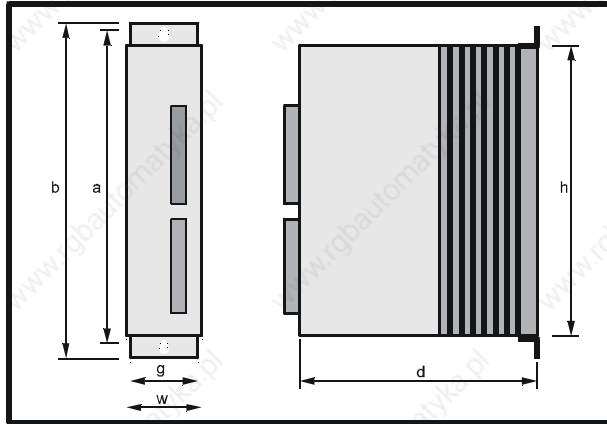

| Dimensions | | Midi-Maestro | | Maxi-Maestro | |
|---|---|--------------|-------|--------------|-------|
| | | mm | in | mm | in |
| Height of case | h | 196 | 7.717 | 196 | 7.717 |
| Width of case | w | 65 | 2.559 | 84 | 3.307 |
| Depth of case | d | 220 | 8.661 | 220 | 8.661 |
| Mounting centres from top mounting bracket to bottom mounting bracket | a | 215 | 8.465 | 215 | 8.465 |
| Height including mounting brackets | b | 235 | 9.252 | 235 | 9.252 |
| Width of mounting bracket | g | 62 | 2.441 | 80 | 3.150 |

2.2.16 Daughter boards

Potentiometers, mounted components and switches fitted on a daughter board are used to configure the drive. If there is a need to replace the drive, and the configuration is required in the replacement, the daughter board can be removed and installed in the replacement drive.

Figure 2-3 Daughter board as supplied by default

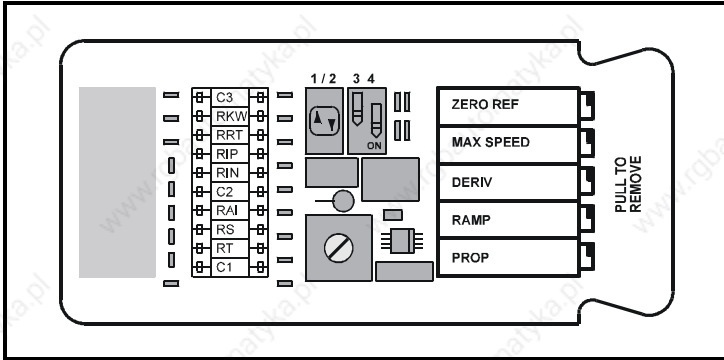

NOTE The set up of this daughter board is explained in further detail in *Chapter 5 Optimisation* on page 5.

NOTE If the drive is an older unit it is possible that alternative daughter boards may be fitted. See *Chapter 7 Miscellaneous* on page 7.

2.2.17 Items supplied with the drive

| Midi Maestro | Maxi Maestro |
|---------------------|-------------------------------------|
| Connector 3425-9115 | Connector 3435-9115 |
| Connector 3439-1109 | External braking resistor 1220-6008 |

3 Mechanical Installation

3.1 Mounting location

Mechanical installation has to take into account points of entry of electrical cables and the fitting of a choke if required.

The drive should be located in a place free from dust, corrosive vapours, gases and all liquids.

Two alternative arrangements for mounting the drive are provided. Depending on the position of mounting brackets, these are:

1. Surface mounted on a panel or in an enclosure
2. Through an aperture in a panel so that the heatsink of the drive projects from the rear of the panel. This arrangement can be used for mounting the drive through the rear panel of an enclosure to allow free circulation of air around the heatsink and to minimize temperature rise inside the enclosure. This can be beneficial if the enclosure is to house a number of drives.

Each mounting bracket is mounted to the heatsink by two self-tapping screws.

Figure 3-1 Details of the mounting brackets

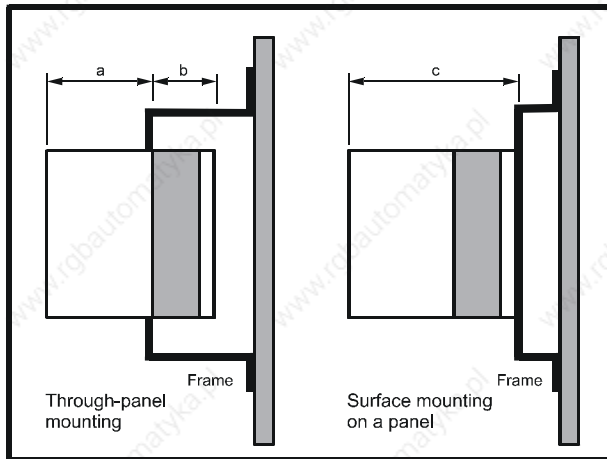

| | Dimensions | mm | in |
|--|------------|-----|-------|
| Through-panel mounting - from brackets to front of the drive | a | 134 | 5.276 |
| Through-panel mounting - from brackets to rear of the drive | b | 84 | 3.307 |
| Surface mounting - from brackets to front of the drive | c | 222 | 8.740 |

Figure 3-2 Midi Maestro upper mounting foot dimensions

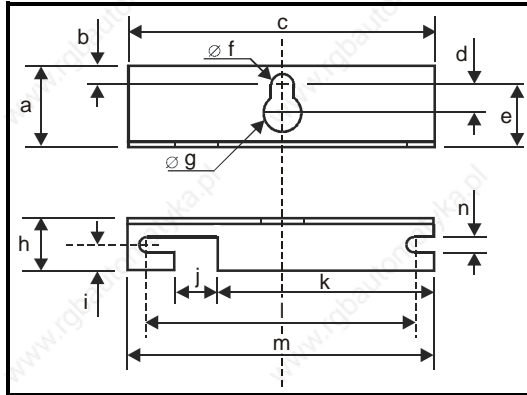

Table 3.1 Midi Maestro upper mounting foot dimensions

| Dimension | mm | in | Dimension | mm | in | Dimension | mm | in |
|-----------|------|-------|-----------|------|-------|-----------|------|-------|
| a | 20.0 | 0.787 | ∅ f | 6.0 | 0.236 | k | 39.0 | 1.535 |
| b | 5.0 | 0.197 | ∅ g | 10.0 | 0.394 | l | 50.0 | 1.969 |
| c | 60.0 | 2.362 | h | 14.0 | 0.551 | m | 60.0 | 2.362 |
| d | 6.0 | 0.236 | i | 5.0 | 0.197 | n | 4.0 | 0.157 |
| e | 15.0 | 0.591 | j | 10.0 | 0.394 | | | |

Figure 3-3 Midi Maestro Lower mounting foot dimensions

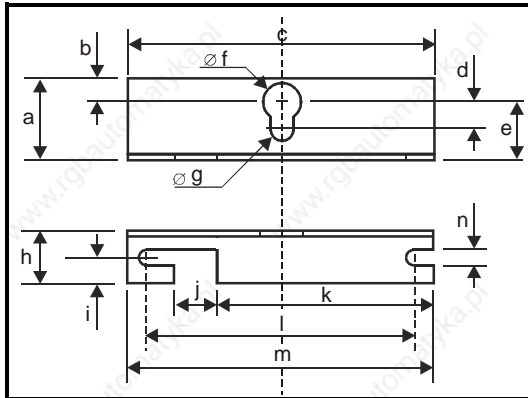

Table 3.2 Midi Maestro upper mounting foot dimensions

| Dimension | mm | in | Dimension | mm | in | Dimension | mm | in |
|-----------|------|-------|-----------|------|-------|-----------|------|-------|
| a | 20.0 | 0.787 | ∅ f | 10.0 | 0.394 | k | 39.0 | 1.535 |
| b | 6.5 | 0.256 | ∅ g | 6.0 | 0.236 | l | 50.0 | 1.969 |
| c | 60.0 | 2.362 | h | 14.0 | 0.551 | m | 60.0 | 2.362 |
| d | 6.0 | 0.236 | i | 5.0 | 0.197 | n | 4.0 | 0.157 |
| e | 13.5 | 0.531 | j | 10.0 | 0.394 | | | |

Figure 3-4 Maxi Maestro upper mounting foot dimensions

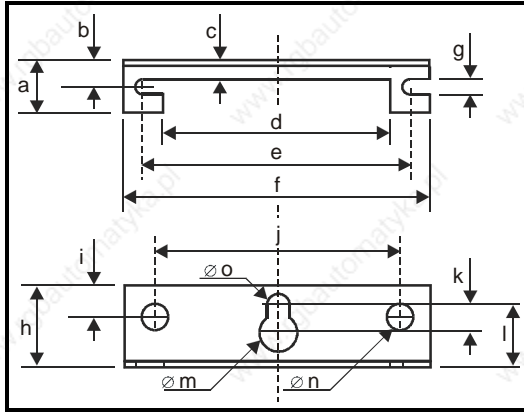

Table 3.3 Maxi Maestro upper mounting foot dimensions

| Dimension | mm | in | Dimension | mm | in | Dimension | mm | in |
|-----------|------|-------|-----------|------|-------|-----------|------|-------|
| a | 14.0 | 0.551 | f | 81.0 | 3.189 | k | 9.0 | 0.354 |
| b | 7.0 | 0.276 | g | 4.0 | 0.157 | l | 15.0 | 0.591 |
| c | 5.0 | 0.197 | h | 20.0 | 0.787 | Ø m | 10.0 | 0.394 |
| d | 60.0 | 2.362 | i | 8.0 | 0.315 | Ø n | 7.0 | 0.276 |
| e | 71.5 | 2.815 | j | 65.0 | 2.559 | Ø o | 6.0 | 0.236 |

Figure 3-5 Maxi Maestro lower mounting foot dimensions

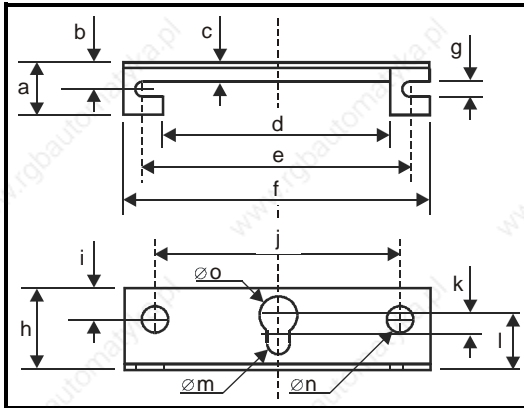

Table 3.4 Maxi Maestro upper mounting foot dimensions

| Dimension | mm | in | Dimension | mm | in | Dimension | mm | in |
|-----------|------|-------|-----------|------|-------|-----------|------|-------|
| a | 14.0 | 0.551 | f | 81.0 | 3.189 | k | 6.5 | 0.256 |
| b | 7.0 | 0.276 | g | 4.0 | 0.157 | l | 12.5 | 0.492 |
| c | 5.0 | 0.197 | h | 19.0 | 0.748 | Ø m | 6.0 | 0.236 |
| d | 60.0 | 2.362 | i | 8.0 | 0.315 | Ø n | 7.0 | 0.276 |
| e | 71.5 | 2.815 | j | 65.0 | 2.559 | Ø o | 10.0 | 0.394 |

3.2 Choke (optional)

When a motor has an inductance value less than the value quoted in the following table, a choke is required. Refer to Figure 3-6 for dimensions.

| Model | Minimum inductance | Required choke | Weight | Part number |
|--------------|--------------------|----------------|----------|-------------|
| Midi-Maestro | 2 mH | L13 | 15.53 kg | 4371-1314 |
| Maxi-Maestro | 3 mH | L14 | 33.10 kg | 4371-1403 |

Figure 3-6 Dimensions of the L13 and L14 chokes

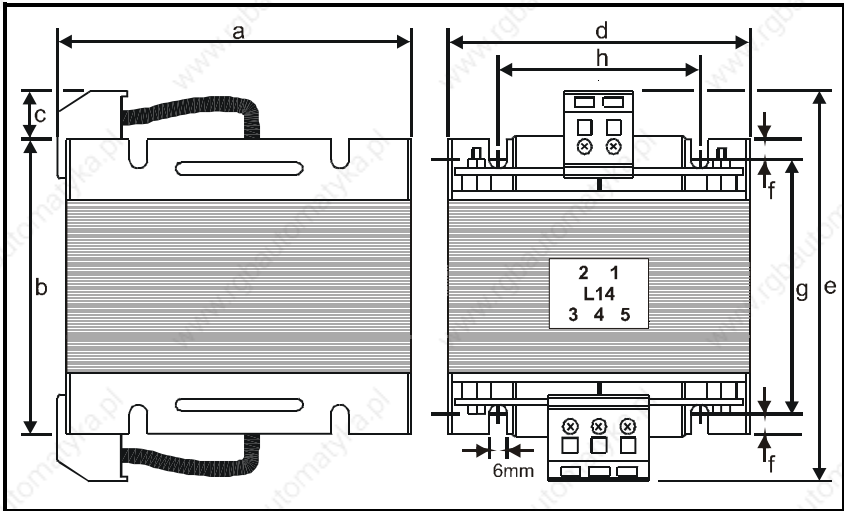

| Dimensions | L13 | | L14 | |
|------------|-----|-------|-----|-------|
| | mm | in | mm | in |
| a | 102 | 4.016 | 127 | 5.000 |
| b | 69 | 2.717 | 100 | 3.937 |
| c | 17 | 0.669 | 17 | 0.669 |
| d | 83 | 3.268 | 105 | 4.134 |
| e | 105 | 4.134 | 132 | 5.197 |
| f | 4 | 0.157 | 7 | 0.276 |
| g | 61 | 2.402 | 86 | 3.386 |
| h | 57 | 2.244 | 70 | 2.756 |

3.3 Braking resistor

When a Maxi-Maestro drive is used, or the internal braking resistor for a Midi-Maestro is insufficient, the drive requires an external braking resistor. A braking resistor is supplied with the Maxi-Maestro drive.

Refer to Figure 3-7 for the dimensions of this braking resistor.

Figure 3-7 Dimensions of the braking resistor

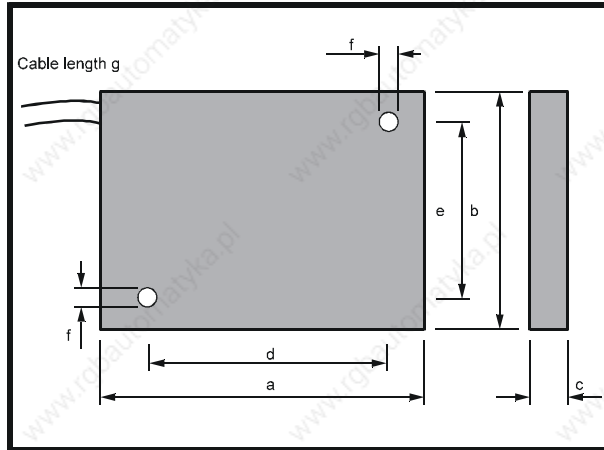

| Dimensions | | mm | in |
|--|---|------|--------|
| Length | a | 102 | 4.016 |
| Height | b | 68 | 2.677 |
| Depth | c | 12.5 | 0.492 |
| Distance between hole centres - length | d | 81 | 3.189 |
| Distance between hole centres - width | e | 57 | 2.244 |
| Hole diameter | f | 4.8 | 0.189 |
| Maximum length of cable | g | 300 | 11.811 |

The use of a braking resistor is covered in greater detail in Chapter 4 *Electrical Installation* on page 14.

| | | | | | | |
|--------------------|---------------------|--------------------------------|-------------------------|--------------|-------------|---------------|
| Safety Information | Product Information | Mechanical Installation | Electrical Installation | Optimisation | Diagnostics | Miscellaneous |
|--------------------|---------------------|--------------------------------|-------------------------|--------------|-------------|---------------|

3.4 Ventilation

Installing in a sealed enclosure

To maintain sufficient cooling of the drive when it is installed inside a sealed enclosure, heat generated by all the equipment must be taken into account and the enclosure must be of adequate size.

The drive must be installed in a vertical position, to ensure the correct airflow is flowing between the cooling fins of the heat-sink. Vertical installation above other drives or any other heat producing equipment may result in overheating.

NOTE The total power dissipated by drives, chokes, transformers and braking resistors is about 12% of the total of the motor rating.

Drives are protected against overheating. When the temperature of the heat-sink reaches 95°C, the drive is disabled. When the temperature subsequently falls to below 95°C the drive is automatically re-enabled.

4 Electrical Installation

Figure 4-1 Locations of the signal and power connections in the Midi-Maestro drive

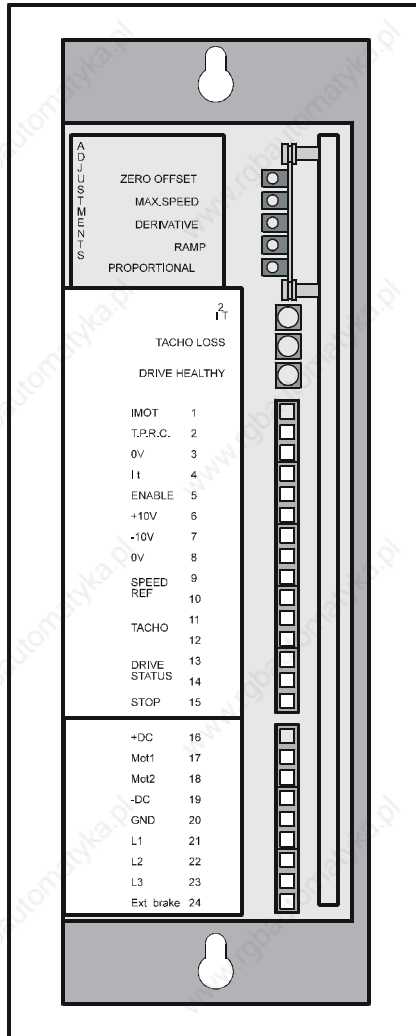

NOTE Signal cables and power cables must be segregated and wired through different trunking.

Figure 4-2 Locations of the signal and power connections in the Maxi-Maestro drive

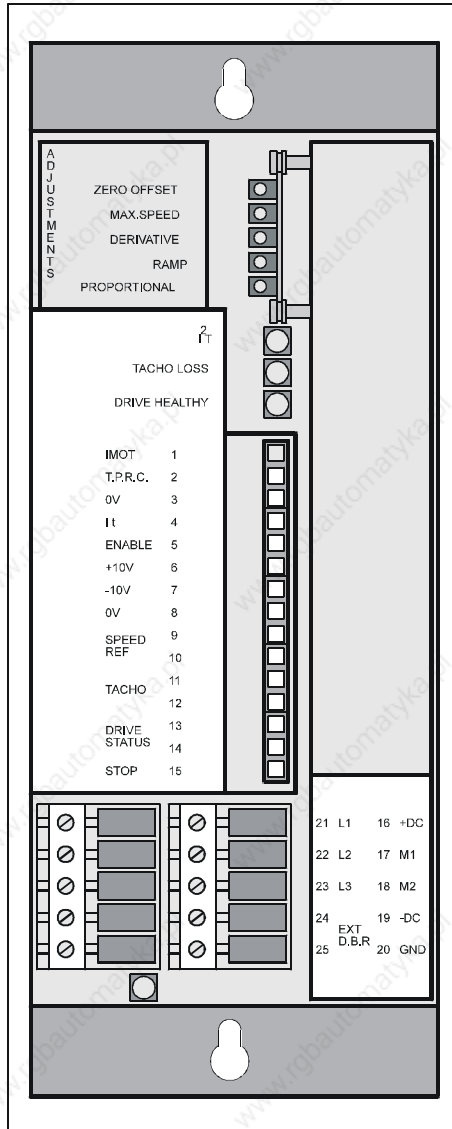

NOTE Signal cables and power cables must be segregated and wired through different trunking.

4.1 Power connector

| Pin No | Description | I/O | Notes |
|--------|-------------|-----|--|
| 16 | +DC | O | + DC bus. |
| 17 | MOT1 | O | + terminal for motor. |
| 18 | MOT2 | O | – terminal for motor. |
| 19 | –DC | O | – DC bus. |
| 20 | E | | Ground. |
| 21 | L1 | I | Phase 1 from three-phase transformer. Line 1 from single-phase transformer. |
| 22 | L2 | I | Phase 2 from three-phase transformer. Line 2 from single-phase transformer. |
| 23 | L3 | I | Phase 3 from three-phase transformer. Note - Transformer secondary wiring must be delta connected. The phase sequence has no effect. |
| 24 | EXT DBR | O | External braking resistor. |
| 25 | EXT DBR | O | (Maxi-Maestro only) External braking resistor. |

An additional braking resistor for the Midi-Maestro drive is connected between pins 24 and 16.

Please refer to section 4.8 *Braking resistor connections* on page 27 for further information.



WARNING

If using an external braking resistor with the Midi-Maestro, the internal braking resistor must be disconnected.

The braking resistor for the Maxi-Maestro is connected between pins 24 and 25.

Please refer to section 4.8 *Braking resistor connections* on page 27 for further information.



WARNING

The supply terminals are not isolated from the control terminals. The AC supply **MUST** be isolated or have its negative pole grounded.

4.2 Transformer power rating

- A single three-phase transformer may be able to supply more than one drive.
- The power rating of the secondary winding must exceed the nominal power rating of the motor.
- When using a transformer with more than one secondary winding, the power rating of the primary must exceed the sum of the power ratings of the secondary windings.



The secondary windings must be delta-connected. (This is not essential for the primary winding.)

4.2.1 Three-phase AC supply

To calculate the necessary adjustments required for each secondary winding, the following equation for **Ps** (in VA) must be used:

$$P_s = |P_{az} \times 1.5| \times \frac{1.73}{\sqrt{|n + 2|}}$$

Where:

$$P_{az} = \{(V_{m1} \times C_{m1}) + (V_{m2} \times C_{m2}) + (V_{mn} \times C_{mn})\}$$

$$V_m = \text{Maximum motor speed in rads/sec} = \text{RPM}/9.55$$

$$C_m = \text{Nominal motor torque in Nm}$$

$$\frac{1.73}{\sqrt{|n + 2|}} = \text{Corrective factor when using more than one drive in parallel}$$

$$n = \text{Number of drives}$$

To calculate the total transformer power in VA, use the following equation:

$$P_t = P_{S1} + P_{S2} + \dots P_{Sn}$$

Where:

PS1 = Power rating of secondary winding 1

PS2 = Power rating of secondary winding 2

PSn = Power rating of secondary winding n

Figure 4-3 Three-phase AC supply and ground connections

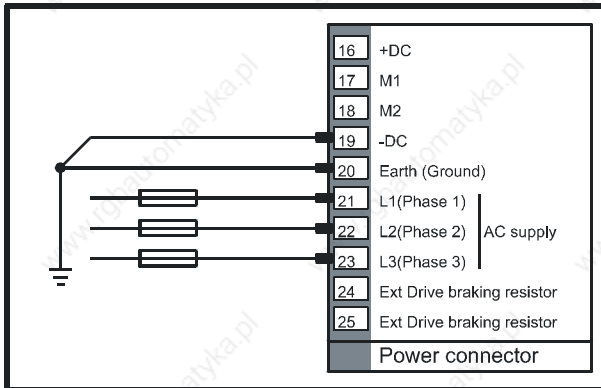

4.2.2 Single-phase AC supply

Model DCD 140 x 8/16 may be operated on a single-phase supply.

The transformer power rating may be calculated using the equation:

$$P_s = |P_{az} \times 1.5| \times \frac{1.73}{\sqrt{|n + 2|}}$$

Where:

P_{az} = {(V_{m1} × C_{m1}) + (V_{m2} × C_{m2}) + (V_{mn} × C_{mn})}

V_m = Maximum motor speed in rads/sec = RPM/9.55

C_m = Nominal motor torque in Nm

$\frac{1.73}{\sqrt{|n + 2|}}$ = Corrective factor when using more than one drive in parallel

n = Number of drives

The secondary winding should be connected to pins 21 and 22 of the power connector.

Figure 4-4 Single-phase AC supply and ground connections

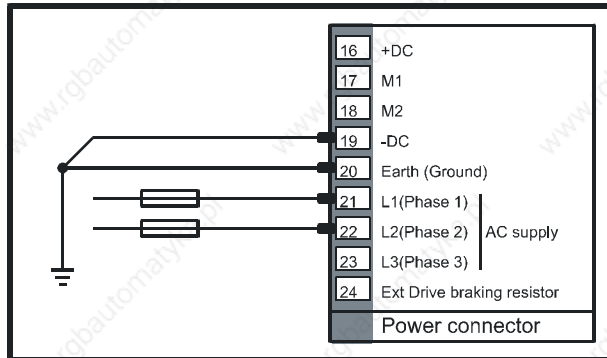

4.3 Supply fuses

A fuse should be fitted in each of the transformer primary and secondary circuits.

Figure 4-5 Fuses in the transformer primary and secondary circuits

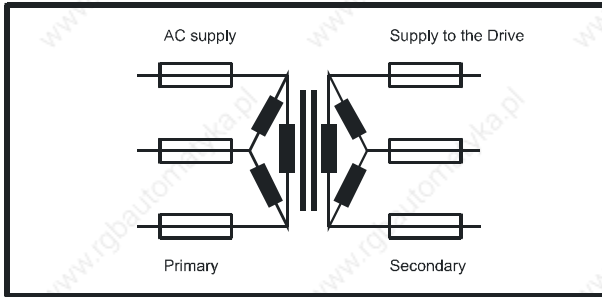

Correct fuse protection must be used to avoid fire risk.

Primary-circuit fuses

Use the following equation to calculate the rating of the fuses in the primary circuit:

$$\text{Amps} = \frac{\text{Transformer VA rating}}{\text{RMS primary rating}}$$

4.3.1 Secondary-circuit fuses

Refer to the following table for the rating of the fuses in the secondary circuit:

| Midi-Maestro 140 × 8/16 | Midi-Maestro 140 × 14/28 | Maxi-Maestro 200 × 25/50 | Maxi-Maestro 100 × 25/50 |
|----------------------------|-----------------------------|-----------------------------|-----------------------------|
| 10 A | 16 A | 30 A | 30 A |

If more than one drive is connected to a secondary winding, it is necessary to install three fuses for each drive.

4.4 DC bus voltage

DC bus voltage without load, $V_{DC} = V_s \times 1.41$

where V_s = transformer secondary voltage (off-load).

The following table shows DC bus voltage and transformer secondary voltage:

| Voltage | Midi-Maestro 140 × 8/16 | Midi-Maestro 140 × 14/28 | Maxi-Maestro 200 × 25/50 | Maxi-Maestro 100 × 25/50 |
|-----------------------|----------------------------|-----------------------------|-----------------------------|-----------------------------|
| DC bus | 150 V | 150 V | 212 V | 100 V |
| Transformer secondary | 105 V | 105 V | 150 V | 70 V |

4.4.1 DC Supply

It is possible to power up the Midi and Maxi Maestro using a DC supply. This can be done by connecting the DC supply directly to the drive's \pm DC Bus terminals (Terminals 16 and 19). When using a DC supply, due to the fact that there is no AC supply, the Braking Circuit will be permanently switched on, requiring the disconnection of the braking resistor.

4.4.2 DC supply fuses

A fuse should be fitted on both the +ve and -ve DC terminals.

| Midi-Maestro 140 \times 8/16 | Midi-Maestro 140 \times 14/28 | Maxi-Maestro 200 \times 25/50 | Maxi-Maestro 100 \times 25/50 |
|-----------------------------------|------------------------------------|------------------------------------|------------------------------------|
| 16 A | 25 A | 50 A | 50 A |



Please contact the supplier for further information before using a DC supply.

4.5 Ground connections

To avoid unnecessary tripping of the drive, one common ground point must be used to connect the signal common and the power common. The shortest possible wiring should be used. Refer to Figure 4-8.

A grounding bar mounted on insulated supports and having the dimensions given in Figure 4-8 may be used.

No significant voltage drop should occur between connections.

The ground connections shown in Figure 4-8 should assist in minimising the effects of signal noise.

The connection to the chassis terminal of the enclosure must be adequately sized.

If in doubt, consult the supplier of the drive.

4.6 Motor connections

Normally the motor should be connected directly to pins 17 and 18 of the power connector as shown in Figure 4-6.

Figure 4-6 Normal motor connections

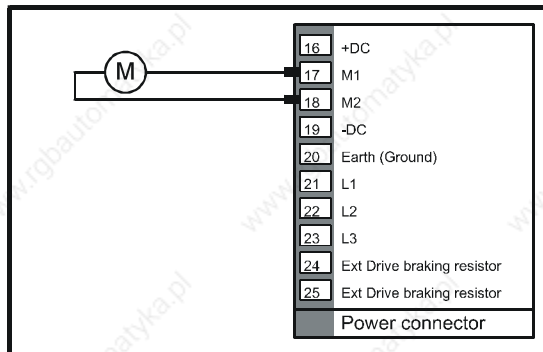

When any of the following conditions apply, a choke should be connected to each drive output as shown in Figure 4-7 and Figure 4-8.

- When a Midi-Maestro drive is being used and the motor inductance is less than 2mH
- When a Maxi-Maestro drive is being used and the motor inductance is less than 3mH
- During emergencies, the user short-circuits the motor connections
- High frequency switching noise is troublesome
- The motor overheats (irrespective of motor inductance)

When a choke is fitted, pin 17 should be connected to terminal 1 of the choke and pin 18 should be connected to terminal 2 of the choke.

Figure 4-7 Motor and choke connections

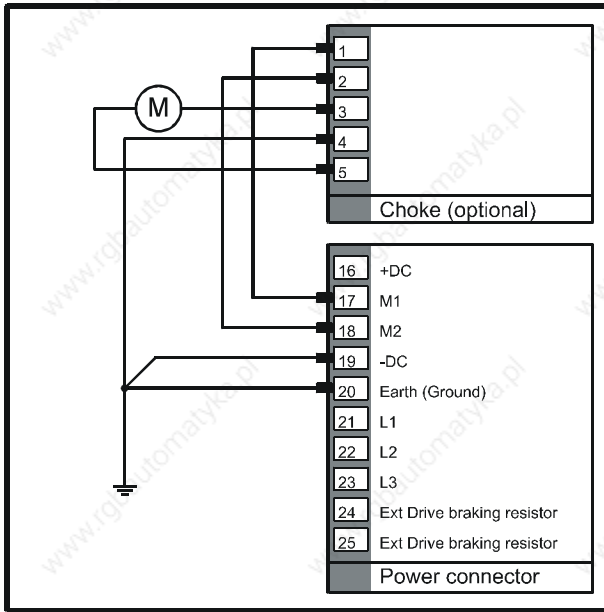

The two cables between the drive and the choke are a source of noise. The cables should be kept as short as possible (300mm is recommended).

Terminal 3 of the choke should be connected to the + terminal of the motor. Terminal 5 should be connected to the - terminal on the motor.

Terminal 4 should be connected to the grounding bar.

Figure 4-8 Typical ground connections

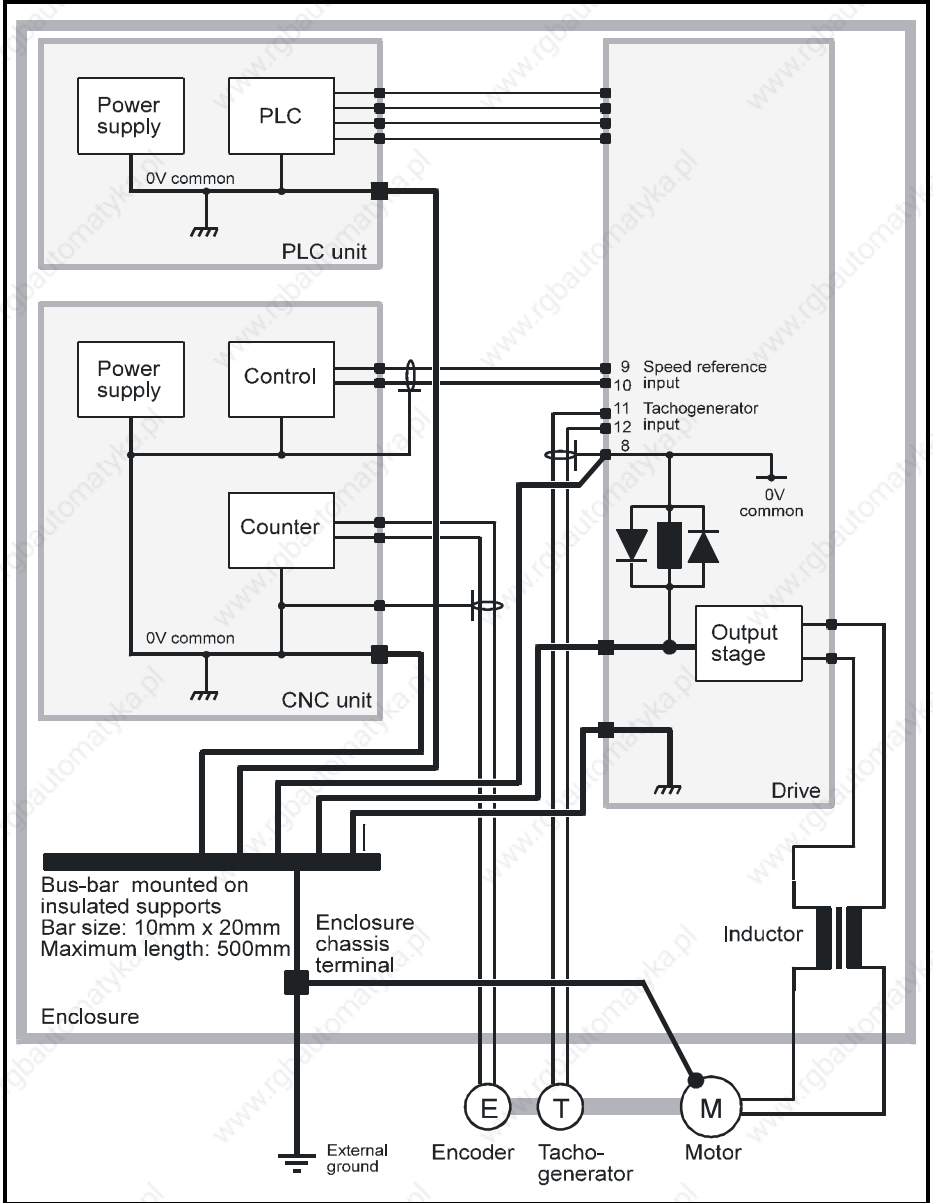
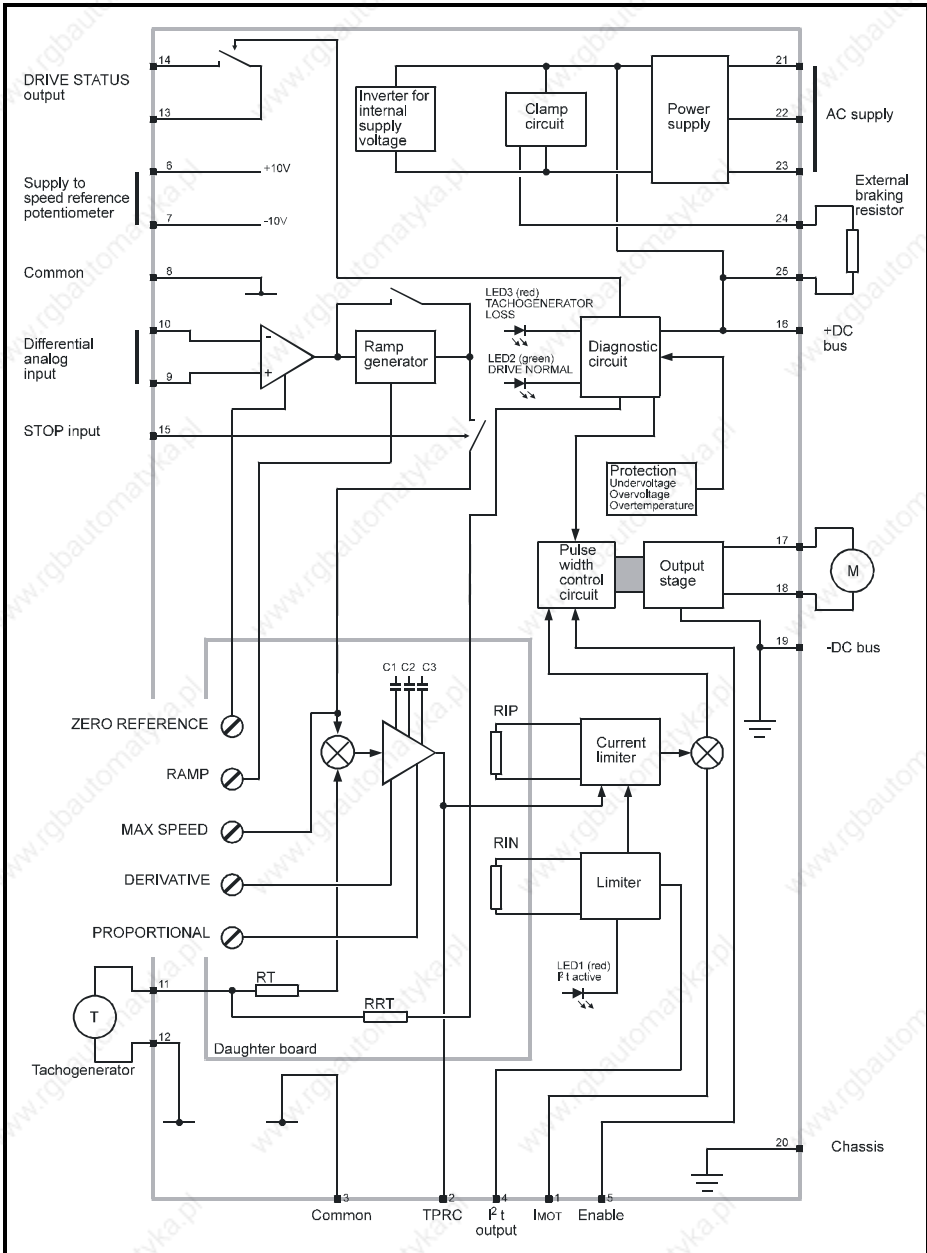

Figure 4-9 Block diagram of the drive



4.7 When to use a braking resistor

When a DC motor is decelerated, or the drive is preventing the motor from gaining speed due to mechanical influences, energy is returned to the drive from the motor. When this energy is too great for the drive to absorb, the DC-bus voltage is raised, which increases the possibility of the drive tripping due to excessive DC-bus voltage.

Depending on the braking requirements, an internal braking resistor, fitted in the Midi-Maestro drive, or an external braking resistor, (which can be used with both the Midi & Maxi-Maestro drives), can be used for absorbing the returned energy. The braking resistor is switched into circuit by an internal transistor when the DC-bus voltage reaches a certain threshold.

This Braking circuit threshold is given by:

$$(AC\ Supply\ voltage \times 1.41) + 18V.$$

When the internal braking resistor fitted in the Midi-Maestro is inadequate, a larger resistor may be connected externally, between pins 16 & 24 of the power connector. Also, if the external braking resistor that is supplied with the Maxi-Maestro is inadequate a larger resistor may be used instead. This should be connected between pins 24 & 25 of the power connector. These connections are shown in Figure 4-11 and Figure 4-12.

The required value for the braking resistor is determined by the amount of energy to be dissipated, the duty cycle and repetition time, as well as the cooling available for the resistor. When the value and power rating have been calculated, a decision can be made whether to use the internal resistor (fitted as default in the Midi-Maestro) or an external resistor (can be used with both Midi & Maxi drives).

NOTE

For External braking resistor calculations see section 4.9 *Braking resistor calculations* on page 29.



If using an external braking resistor with the Midi-Maestro, the internal braking resistor must be disconnected.

4.7.1 Braking resistor data

Midi-Maestro

Internal braking resistor - Fitted as standard

| Midi-Maestro 140x8/16 | Midi-Maestro 140x14/28 |
|-----------------------|------------------------|
| 10Ω, 200W | |
| Min value = 10Ω* | |

NOTE

* The minimum resistor value has been set to limit the current, through the braking circuit, to protect the drive if a larger rated external braking resistor is required.

Maxi-Maestro

External braking resistor

When a Maxi-Maestro drive is used, due to the fact that there is no internal braking resistor, an external braking resistor is required. The braking resistor defined below is supplied with the drive.

| | |
|-------------------------------|----------------------------------|
| Maxi-Maestro 200x25/50 | Maxi-Maestro LV 100x25/50 |
| 8Ω, 600W | |
| Min value = 8Ω* | |

NOTE

* The minimum resistor value has been set to limit the current, through the braking circuit, to protect the drive if a larger rated external braking resistor is required.

Figure 4-10 Dimensions of the External Braking Resistor

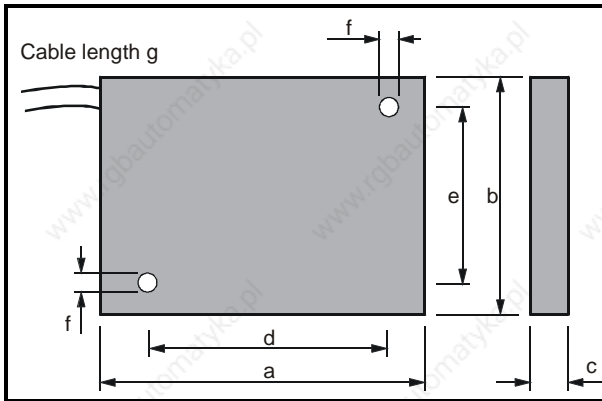

| Dimensions | | mm | in |
|--|---|------|--------|
| Length | a | 102 | 4.016 |
| Height | b | 68 | 2.677 |
| Depth | c | 12.5 | 0.492 |
| Distance between hole centres - length | d | 81 | 3.189 |
| Distance between hole centres - width | e | 57 | 2.244 |
| Hole diameter | f | 4.8 | 0.189 |
| Maximum length of cable | g | 300 | 11.811 |

4.7.2 Braking resistor precautions



Electric shock risk

The voltages present on the braking resistor, its associated components and terminals on the drive are capable of inflicting a severe electric shock and may be lethal.



Thermal overload protection

When an external braking resistor is used, it is essential that a thermal overload protection device is incorporated in the braking-resistor circuit in order to minimise the risk of fire in the event of unexpectedly high current, or loss of control of the braking circuit. A typical protection circuit is shown in the following section - Thermal protection of the braking resistor.



If using an external braking resistor with the Midi-Maestro, the internal braking resistor must be disconnected. Failure to do so can result in damage to the drive.

4.7.3 Thermal protection of the braking resistor



High temperatures

Braking resistors can attain high temperatures and should be segregated from temperature-sensitive equipment and personnel.

When an external braking resistor is used with either a Midi or a Maxi-Maestro, a thermal-protection circuit must be added. This must disconnect the AC supply from the drive if the braking resistor becomes overloaded. (see Figure 4-11 and Figure 4-12 for guidance).

When the internal braking resistor is used (Midi-Maestro only) a thermal-protection circuit is not required since the thermal protection in the drive causes the drive to disable when the temperature of the heat-sink reaches 95°C. When the temperature subsequently falls to below 95°C the drive is automatically re-enabled.

4.8 Braking resistor connections

4.8.1 Fitting an internal braking resistor with Midi-Maestro

An internal braking resistor is installed in the drive. When this is inadequate, a larger resistor may be connected externally.

4.8.2 Fitting an external braking resistor with Midi-Maestro

The external braking resistor should be connected between pins 16 and 24 of the power connector.

As stated, should an external braking resistor be required with a Midi-Maestro drive, the internal braking resistor must be disconnected first.

To disable the internal braking resistor, the drive must be disconnected from the supply and allowed to discharge. Remove the top cover and unplug the two red braking resistor spade crimped leads. These leads should then either be totally removed, or adequately secured and isolated from the rest of the drive (allowing the option of re-fitting, if required).

Connect the external braking resistor as shown in Figure 4-11.

Figure 4-11 Braking resistor connections for the Midi-Maestro drive

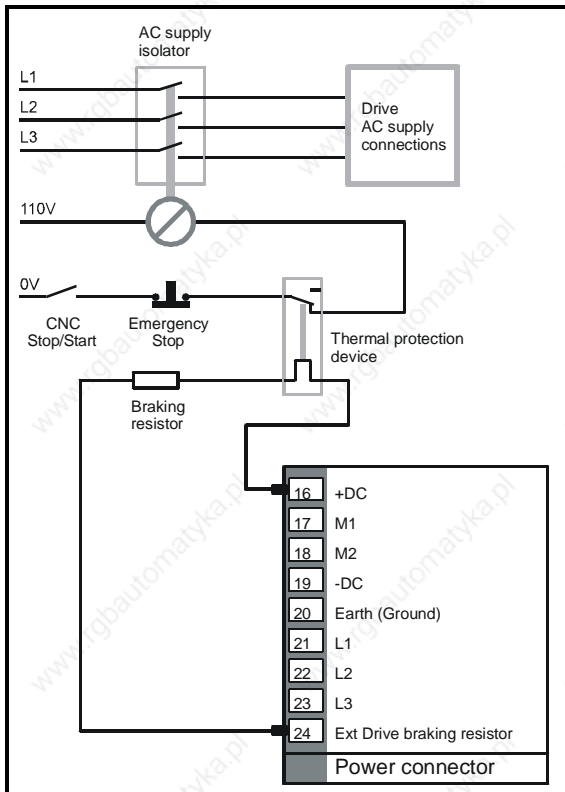

4.8.3 Fitting an external braking resistor with Maxi-Maestro

An external braking resistor is supplied and must be mounted close to the drive. When this is inadequate a larger resistor may be used instead.

The braking resistor should be connected between pins 24 and 25 of the power connector.

Figure 4-12 Braking resistor connections for the Maxi-Maestro drive

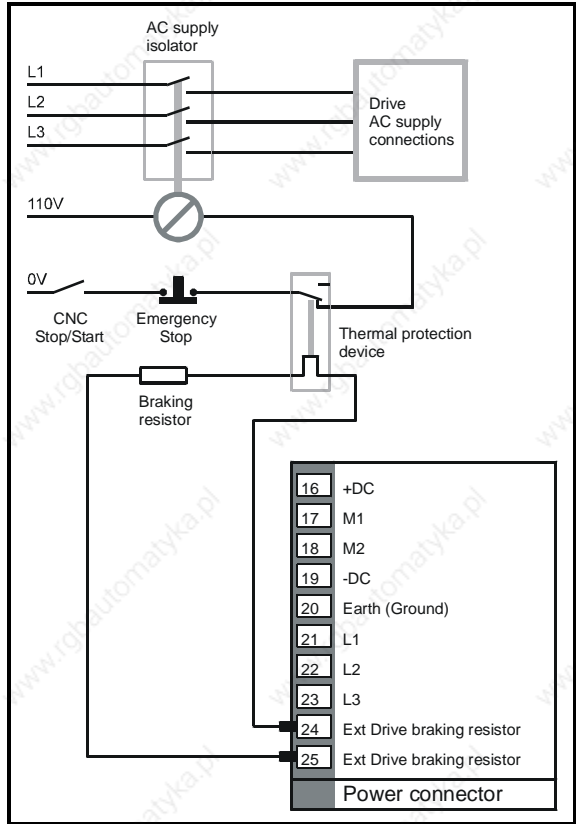

| | | | | | | |
|--------------------|---------------------|-------------------------|--------------------------------|--------------|-------------|---------------|
| Safety Information | Product Information | Mechanical Installation | Electrical Installation | Optimisation | Diagnostics | Miscellaneous |
|--------------------|---------------------|-------------------------|--------------------------------|--------------|-------------|---------------|

4.9 Braking resistor calculations

The following section details the parameters required and formula to be used in order to calculate the braking resistor rating.

Example:

Model: Midi-Maestro 140 x 14/28

Motor: DCM 60 30/14

Maximum peak output current (I_{pk}) from the drive (for 2 seconds maximum): 28 A

Full-load speed (n) of motor: 3,000 rpm

Continuous stall torque (T_{CS}) of motor: 5.5 Nm

Motor K_T : 0.39 Nm/A

Motor inertia (J_M): 2.8×10^{-3} kgm²

Load inertia (J_L): 28.2×10^{-3} kgm²

Total inertia ($J_T = J_M + J_L$): 31×10^{-3} kgm²

Required deceleration time (t_d) from full to zero speed: 1 s

Repeat cycle time for deceleration (t_r): 7 s

Operating voltage (V_R) at switch on = (AC supply x 1.41 + 18): 180 V

4.9.1 Minimum permissible deceleration time

The minimum permissible deceleration time is limited by the following:

- The peak current of the drive (I_{pk})
 - The *intermittent torque limit* of the motor (the value of torque that the motor can deliver for a specified time - see the motor manufacturer's data)
1. Calculate the maximum torque that the motor would produce when the drive is delivering peak current as follows:

$$M_{bDRIVE} = I_{pk} \times K_T$$

$$M_{bDRIVE} = 28 \times 0.39 = 10.92 \text{ Nm}$$

The drive would cause this value of torque to be produced for up to 2 seconds.

2. Refer to the motor manufacturer's data to obtain the permissible overload (continuous stall torque) for 2 seconds. Then use this figure to calculate the intermittent torque limit for the motor for a 2-second duration. For this example, 3 times the nominal torque rating is assumed, as follows:

$$M_{bINT} = T_{CS} \times 3$$

$$M_{bINT} = 5.5 \times 3 = 16.5 \text{ Nm}$$

3. For calculating the minimum permissible deceleration time (t_{bMIN}), use the lower of the two calculated values.

$$M_{bMAX} = 10.92 \text{ Nm}$$

| | | | | | | |
|--------------------|---------------------|-------------------------|--------------------------------|--------------|-------------|---------------|
| Safety Information | Product Information | Mechanical Installation | Electrical Installation | Optimisation | Diagnostics | Miscellaneous |
|--------------------|---------------------|-------------------------|--------------------------------|--------------|-------------|---------------|

4. The following equation is used as the basis for the calculations:

$$M_b = \frac{J_T n}{t_b} \times \frac{\pi}{30} (Nm)$$

Use the following derivative of the equation to calculate the minimum permissible deceleration time (t_{bMIN}) for stopping the motor from full-load speed:

$$t_{bMIN} = \frac{J_T \pi n}{30 M_{bMAX}}$$

$$t_{bMIN} = \frac{31 \times 10^{-3} \times \pi \times 3000}{30 \times 10.92} = 0.89s$$

Check that t_{bMIN} is less than td ; if not, system design must be reconsidered.

4.9.2 Resulting torque

Calculate the torque that results from the required deceleration time, as follows:

$$M_b = \frac{J_T n}{t_d} \times \frac{\pi}{30} (Nm)$$

$$M_b = \frac{31 \times 10^{-3} \times 3000 \times \pi}{1 \times 30} = 9.74Nm$$

4.9.3 Power rating of the braking resistor

1. Calculate the kinetic energy (E_K) that will be dissipated in the braking resistor, as follows:

$$E_K = 0.5 \times J_T \times \left(\frac{n \times \pi}{30} \right)^2$$

$$E_K = 0.5 \times 31 \times 10^{-3} \times \left(\frac{3000 \times \pi}{30} \right)^2 = 1530J (1.53KJ)$$

2. Calculate the average power over deceleration time (td):

$$P_{PK} = \frac{E_K}{td}$$

$$P_{PK} = \frac{1.53 \times 10^3}{1} = 1530kJ$$

- Calculate the average power (P_{av}) that will be dissipated over the whole cycle:

$$P_{av} = \frac{E_K}{tr}$$

$$P_{av} = \frac{1.53 \times 10^3}{7} = 219W$$

If the value of P_{av} is less than the supplied resistor's continuous braking power rating (refer to the tables in section 4.7.1 *Braking resistor data* on page 24), then that resistor can be used. However, if P_{av} is greater than the resistor's continuous braking power rating, as in this example, a higher rated resistor should be used to reduce the risk of the drive tripping under braking.

- Since braking is planned to occur intermittently, an external resistor can be rated for *intermittent* rather than *continuous* power dissipation so that the overload factor of the resistor can be used. This factor can be obtained from cooling curves for the resistor, as shown in Figure 4-13.

Figure 4-13 Example cooling curves for power resistors (in practice, refer to the cooling curves for the resistor to be used)

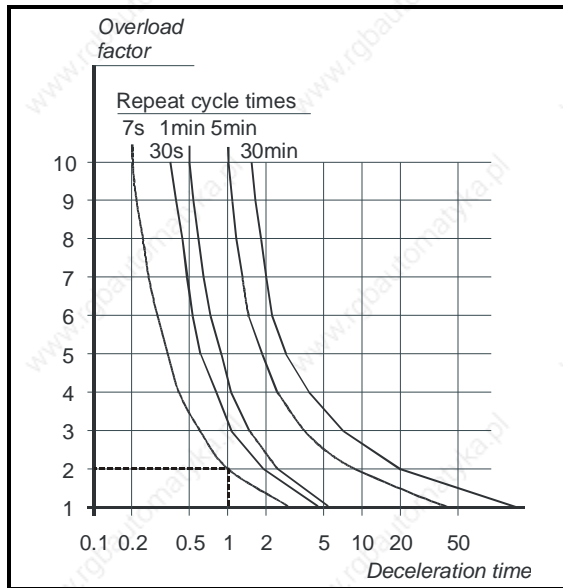

- The cooling curves indicate that for a braking time of 1 second and repeat cycle time of 7 seconds, the overload factor (F) is 2.

6. Calculate the minimum required power rating of the resistor, as follows:

$$P_{RMIN} = \frac{P_{PK}}{F}$$

$$P_{RMIN} = \frac{1530}{2} = 765 W$$

If the braking resistor is to be mounted inside the enclosure, make a note of this value; you will need it when calculating the enclosure size.

In practice, use a resistor having a power rating higher than the calculated value.

For this example: 1kW

4.9.4 Value of the braking resistor

1. Calculate the maximum suitable value for the braking resistor, as follows:

$$R_{MAX} = \frac{(V_R)^2}{P_{PK}}$$

$$R_{MAX} = \frac{180^2}{1530} = 21.18 \Omega$$

2. In practice, use a resistor having a preferred value close to and lower than the calculated value. This is because the calculated value would cause the braking transistor to be switched on almost continuously during braking. In this case, the drive will not have full control of the DC-bus voltage. A lower value of braking resistor will cause the braking transistor to act as a chopper which will then allow the drive to control the DC-bus voltage more accurately.

The reduction in value does not increase the power dissipation since the average voltage across the resistor is reduced by the braking transistor operating as a chopper. For this example, **R = 10Ω**.

4.9.5 Current setting for a thermal overload protection relay

1. Calculate the maximum permissible continuous current through the braking resistor that is to be used, as follows:

$$I_{Rmax} = \sqrt{\frac{P_R}{R}}$$

$$I_{Rmax} = \sqrt{\frac{1000}{10}} = 10 A$$

where:

P_R is the continuous power rating of the resistor to be used (not the minimum required power rating)

R is the actual value of the braking resistor (not the calculated value)

2. Select a model of thermal overload relay that can be set at **10A**

- Calculate the maximum current that could flow through a resistor (e.g. due to the braking resistor becoming short circuit), as follows:

$$I_{RpK} = \frac{V_R}{R}$$

$$I_{RpK} = \frac{180}{10} = 18A$$

- Calculate the overload factor for this condition, as follows:

$$F_{SIC} = \frac{I_{RpK}}{I_{SET}}$$

$$F_{SC} = \frac{18}{10} = 1.8A$$

- Use the tripping curves to find the time that the thermal overload relay will take to trip (e.g. 30 seconds approximately).

Figure 4-14

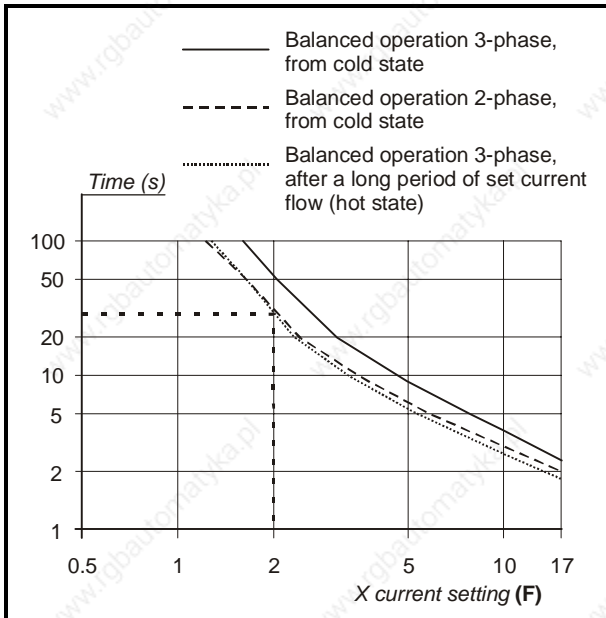

4.10 Signal connections

NOTE Signal cables and power cables must be segregated and wired through different trunking.

| Pin No | Description | I/O | Notes |
|--------|----------------------------------|-----|--|
| 1 | I _{MOT} | O | Analog signal proportional to the effective current in the motor. Output signal $\pm 8V$ at maximum current. |
| 2 | TPRC | I/O | Analog signal proportional to the value of the requested current. Signal range $\pm 10V$. When at $\pm 10V$ the drive generates peak current. When used as an input, and the same voltage range is applied, the drive becomes a current amplifier using the applied voltage as current reference. Torque reference Higher resolution can be achieved by removing a resistor on the daughter board. This disables the speed loop. |
| 3 | 0V | | Internally connected to: Pin 8 (0V) Pin 12 (Tacho) Ground Pin 19 (-DC) |
| 4 | I ² _t | O | A signal is produced from this output during I ² _t current limiting and the LED I ² _t is lit. Maximum voltage available is 47V. Drive capability when no signal is given is 100mA. |
| 5 | ENABLE | I | When a 10V DC to 30V DC signal is applied to this pin, the drive is enabled. When the signal is discontinued, the drive is disabled (0V). |
| 6 | +10V reference | O | 3mA max |
| 7 | -10V reference | O | 3mA max |
| 8 | 0V | | Common |
| 9 | SPEED REF. (inverting input) | I | The speed reference signal input is a differential input to minimize noise problems. |
| 10 | SPEED REF. (non-inverting input) | I | When a differential signal from the external controller is not available, connect pin 9 to pin 8. |
| 11 | TACHO (non-inverting input) | I | Tachogenerator signal. |
| 12 | TACHO (inverting input) | I | Tachogenerator signal. |
| 13 | DRIVE STATUS | O | Pins 13 and 14 internally connected through a contact when the green LED is lit and the drive is running. |
| 14 | DRIVE STATUS | O | When a protection functions is active, the contact is open. The outputs are volt free. The contact drive capability is 30 V DC at 5A. |
| 15 | STOP | I | When 10V DC to 30V DC is applied, the STOP function is enabled. This is a controlled STOP giving torque at zero speed. |

5 Optimisation

5.1 Setting up the drive

Potentiometers, mounted components and switches fitted on a daughter board are used to configure the drive. If there is a need to replace the drive, and the configuration is required in the replacement, the daughter board can be removed and installed in the replacement drive.

NOTE An RT resistor is fitted as standard. The value is 5.1kΩ for tachogenerator voltage constant, $K_e = 10$ and maximum motor speed = 3000 RPM.

Switch 1/2 and 4 are set at ON

Switch 3 is set at OFF.

NOTE The daughter board fitted to the drive may be different in layout to the one described. If this is the case, refer to section 7.1 *Alternative daughter boards* on page 59.

5.2 Potentiometers

Five potentiometers are labelled as follows:

- ZERO REF
- MAX SPEED
- DERIVATIVE
- RAMP
- PROPORTIONAL GAIN

Figure 5-1 Daughter board

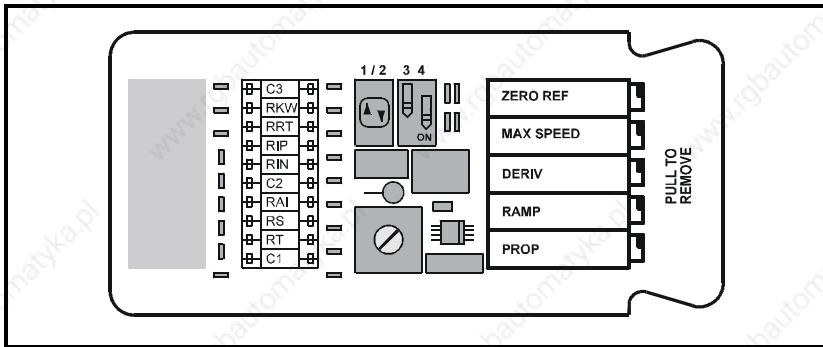

ZERO REF potentiometer

Adjust this potentiometer to cancel any offset in the external speed reference signal.

MAX SPEED potentiometer

Turn the potentiometer anti-clockwise to reduce the maximum motor speed to 50%.
Turn the potentiometer clockwise to increase the maximum motor speed to 120%.

DERIVATIVE potentiometer

Turn the potentiometer clockwise to reduce the amount of overshoot in the system response by increasing the derivative gain of the PID amplifier.

RAMP potentiometer

Adjust the potentiometer to increase or decrease the time the motor reaches maximum speed from 0 second to 2 seconds

PROPORTIONAL potentiometer

Turn the potentiometer clockwise to increase the proportional gain of the PID amplifier.

5.3 Switches

The standard settings for the switches are as follows:

| | |
|---------------------|-----|
| Switch 1 / 2 | ON |
| Switch 3 | OFF |
| Switch 4 | ON |

Switch 1 / 2

| | |
|------------|--|
| ON | Enables speed control with tachogenerator feedback and disables the armature feedback function. When used in this position, remove RAI resistor. |
| OFF | Disables speed control with tachogenerator feedback and enables the armature feedback function. |

Switch 3

| | |
|------------|---------------------------------|
| ON | Enables tacho loss protection. |
| OFF | Disables tacho loss protection. |

Switch 4

| | |
|------------|--|
| ON | Disables acceleration and deceleration ramp. |
| OFF | Enables acceleration and deceleration ramp. |

Figure 5-2 ON and OFF positions of the switches

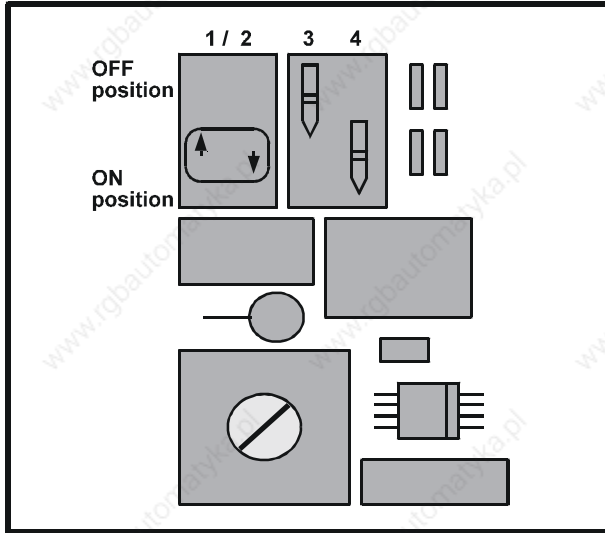

5.4 Mounted components

The following resistors and capacitors may be required to be fitted on the daughter board:

RKW resistor

Adjusts the drive for armature voltage speed feedback.

RRT resistor

Adjusts the drive for tachogenerator loss protection.

RIP resistor

Reduces the peak current to the desired value.

RIN resistor

Reduces the nominal current to the desired value.

RAI resistor

Compensates for the voltage drop due to internal resistance of the motor.

RS resistor

Adjusts the amount of zero-speed torque applied to the motor when a STOP signal is applied to the drive.

| | | | | | | |
|--------------------|---------------------|-------------------------|-------------------------|---------------------|-------------|---------------|
| Safety Information | Product Information | Mechanical Installation | Electrical Installation | Optimisation | Diagnostics | Miscellaneous |
|--------------------|---------------------|-------------------------|-------------------------|---------------------|-------------|---------------|

RT resistor

Normalizes the tachogenerator input signal and adapts the drive to the voltage constant of the tachogenerator.

C1 capacitor

Adjusts integral gain.

C2 capacitor

Adjusts derivative gain.

C3 capacitor

Adjusts the response of the system when the drive is in armature feedback mode.

NOTE Most applications do not require C1, C2 or C3 to be used. When an application does require these capacitors, the recommended value is between 0.1 μ F and 5 μ F.

NOTE Alternative daughter boards may be fitted. If so, refer to Chapter 7 *Miscellaneous* on page 59.

5.5 Making adjustments to the Midi-Maestro drive

5.5.1 Zero speed offset

ZERO REF potentiometer

1. Connect the non-inverting input of the speed reference signal to pin 9 and the inverting input to pin 10.
2. Set the speed reference signal for zero speed.
3. Remove the connection from pin 15 (STOP signal).
4. Connect a digital multimeter to pins 11 and 12.
5. Enable the drive and adjust the ZERO REF potentiometer to reduce the multimeter reading to not more than 1mV.
6. Restore the original wiring.

If the motor is creeping with a zero speed reference, or when a stop command is applied, please contact the supplier of the drive.

5.5.2 Maximum speed

RT resistor

Use the following equation to calculate the value of the RT resistor:

$$RT = 200 [(V_m \times K_{e_{tacho}}) - 5]$$

Where:

V_m = Maximum speed of motor in RPM / 1000

K_{e_{tacho}} = Tachogenerator voltage constant

Resistor ratings:

Power: 0.25W

Tolerance: ±5%.

NOTE If the calculated value of RT is zero, fit a link instead of a resistor.

If the calculated value is negative, the tachogenerator must be changed for one with a greater value of K_{e_{tacho}} in order for the motor to reach the required speed.

Example 1

Max required speed = 3000 RPM

Tachogenerator output = 7V at 1000 RPM

1. Calculate:

$$RT = 200 [(3 \times 7) - 5] = 3.2k\Omega$$

The value of the RT resistor may be between 2.7kΩ and 3.9kΩ.

2. Fit the resistor.
3. Apply speed reference signal of 2V to 10V to pins
4. 9 and 10. (To generate this signal, use the external controller or the reference voltage output on pins 6 and 7.)
5. Measure the reference signal applied to pins 9 and 10 and calculate the tachogenerator output value using the equation:

$$V_{dt} = \frac{RPM \times V_{ref} \times K_{e_{tacho}}}{10,000}$$

Where:

RPM = Maximum required speed

V_{ref} = Measured reference signal

K_{e_{tacho}} = Tachogenerator voltage constant

Example 2

Max required speed = 3000 RPM

Vref = 5V

K_e_{tacho} = 10 (10V at 1000 RPM)

$$\mathbf{Vdt} = \frac{3000 \times 5 \times 10}{10,000} = 15\mathbf{V}$$

Measure the tachogenerator output voltage with a digital multimeter and adjust the maximum speed for the multimeter to show the calculated value.

Calibration should be optimized using a speed indicator.

5.5.3 Adjusting the nominal current

When the nominal current rating of the motor is less than the nominal current of the drive, it is possible to reduce the maximum value of current produced by the drive by fitting a RIN resistor.

Use the following equation to calculate the value of the RIN resistor:

$$\mathbf{RIN} = \frac{|1,000 \times I_{\mathbf{NOM}}|}{\left| |0.1925 \times I_{\mathbf{PEAK}}| - |0.385 \times I_{\mathbf{NOM}}| \right|}$$

Where:

I_{NOM} = nominal desired current value

I_{PEAK} = Drive peak current value



Correct setting of RIN resistor is necessary to prevent damage to the motor and to avoid a fire risk in the event of an overload.

NOTE

I_{PEAK} is a threshold level which is $2 \times I_{\mathbf{NOM}}$ of the drive.

When the value of the required nominal current is reduced, the resulting **I_{PEAK}** current may be more than $2 \times I_{\mathbf{NOM}}$ before the I^2t protection reduces the peak current to the nominal value.

In this case, the peak current is supplied for less than 2 seconds. Added protection is required to stop the **I_{PEAK}** value increasing to more than $2 \times I_{\mathbf{NOM}}$. See section 5.5.7 *Zero speed torque* on page 43.

When **I_{NOM}** is the theoretical nominal current, and the denominator equals zero, RIN should be open circuit.

Example 3

To calculate a value for RIN for Model 140 × 8/16 for 5A nominal current.

$$RIN = \frac{|1000 \times 5|}{||0.1925 \times 16| - |0.385 \times 5||}$$

$$= 4329\Omega$$

Where:

5 = the required nominal current

16 = the theoretical peak current of the drive

The following table may be used for finding an approximate value of I_{NOM} :

| RIN | Midi-Maestro 140 × 8/16 | Midi-Maestro 140 × 14/28 |
|-------------|-------------------------|--------------------------|
| kΩ | I_{NOM} | I_{NOM} |
| | 8 | 14 |
| 18.0 | 7 | |
| 15.0 | | 12 |
| 7.5 | 6 | |
| 6.8 | | 10 |
| 4.7 | 5 | |
| 3.3 | | 8 |
| 2.7 | 4 | |
| 1.8 | | 6 |
| 1.0 | | 4 |

5.5.4 Adjusting the peak current

RIP resistor

When a RIN resistor is fitted, I_{PEAK} may become excessively high in relation to I_{NOM} . To reduce the value of the peak current, use a RIP resistor.

NOTE The new value for I_{PEAK} must be ignored when the value of RIN is calculated.

Use the following equation to calculate the value of the RIP resistor:

$$RIP = \frac{|2200 \times I_{LIM}|}{|I_{PEAK} - I_{LIM}|} \text{ k}\Omega$$

Where:

I_{LIM} = the new value required for I_{PEAK}

NOTE When the peak current is reduced, the ratio between I_{PEAK} and I_{NOM} is altered. This alteration increases the time before I^2t protection takes place.

In this case, the peak current is supplied for more than 2 seconds.

The following table may be used for finding an approximate value for I_{PEAK} :

| RIP | Midi-Maestro 140 × 8/16 | Midi-Maestro 140 × 14/28 |
|-------------|----------------------------|-----------------------------|
| kΩ | I_{PEAK} | I_{PEAK} |
| | 16 | 28 |
| 15.0 | | 26 |
| 12.0 | 14 | |
| 8.6 | | 24 |
| 6.8 | 12 | 22 |
| 5.6 | | 20 |
| 3.9 | 10 | 18 |
| 2.7 | | 16 |
| 2.2 | 8 | |

5.5.5 Adjusting tacho loss protection

RRT resistor

1. Set Switch 3 at ON to enable tacho loss protection.
2. Use the following equation to calculate the correct value for the RRT resistor:

$$RRT = [(0.068 \times V_m \times K_{e_{motor}}) - 1] \times 183000$$

Where:

V_m = Maximum speed in RPM/1000

$K_{e_{motor}}$ = Motor voltage constant (voltage at 1000 RPM - in general V x 1000/RPM)

Example 4

Max speed = 3000 RPM

$V_m = 3$

Motor voltage constant (at 1000 RPM), $K_{e_{motor}} = 15$

$$RRT = [(0.068 \times 3 \times 15) - 1] \times 183000 = 376980\Omega$$

5.5.6 Adjusting speed for operation in armature feedback mode

RKW resistor

Armature feedback mode can be used when a tachogenerator is not fitted to the motor. Speed control is then less precise. Speed is controlled by using the motor voltage as feedback.

Voltage drop due to motor resistance can be compensated by adjusting the value of the RAI resistor.

1. Set Switch 1/2 at OFF to enable operation with armature feedback.
2. Set Switch 3 at OFF to disable tachogenerator loss protection.
3. Use the following equation to calculate the correct value of RKW resistor:

$$RKW = 132 \times V_m \times K_{e_{motor}}$$

Where:

V_m = Maximum speed in RPM/1000

$K_{e_{motor}}$ = Motor voltage constant (voltage at 1000 RPM - in general $V \times 1000/\text{RPM}$)

4. Calculating the value of the RAI resistor can be difficult since it is a function of the following:

- Motor characteristics. (eg. armature resistance and temperature).
- Brush resistance (changing with wear)

An approximate value may be found experimentally using a RAI resistor value of 400k Ω to 600k Ω .



Too low a value for the RAI resistor may modify the velocity loop response. For guidance, contact Control Techniques.

5.5.7 Zero speed torque

RS resistor

No resistor is fitted as standard. Mount an RS resistor to adjust the amount of torque current to be applied to the motor when the drive has received a STOP command.

The RS resistor value is a function of the following:

- Motor characteristics (e.g. armature resistance and temperature)
- Brush resistance (changing with wear)

To achieve an accurate value, it is advisable to carry out a simple test by fitting a 2.2M Ω potentiometer in the RS location, enable the drive and set the potentiometer to reach the required torque level. It is recommended that when the value of RS is established, you replace the potentiometer with a conventional resistor.

5.5.8 Dynamic calibration

For modifying the settings, the following equipment is required:

Low frequency function generator

Frequency range: 0Hz to 10MHz

Output voltage: $-3.5V$ to $+3.5V$

Twin-trace storage oscilloscope.

1. Remove the speed reference signal from pins 9 and 10.
2. Connect the function generator output to pins 9 and 10.
3. Set the function generator at the following:
 - Square wave output
 - Amplitude: $\pm 2V$
 - Frequency: 0.2Hz
4. Connect oscilloscope channel A to pin 11.
5. Connect oscilloscope channel B to pin 1.
6. Connect oscilloscope ground to pin 8.

7. Connect the oscilloscope external trigger input to the function generator output.
8. Set the oscilloscope as follows:
 - Sensitivity: 1mV per division
 - Timebase: 20ms per division



When the motor load is a slide with limited travel, avoid the slide activating the limit switches by increasing the reference signal frequency or decreasing the reference signal amplitude in order to reduce the speed.

NOTE

The minimum acceptable amplitude for the reference signal is 1V peak-to-peak.

9. Apply power to the drive.
10. Enable the drive.
11. The waveform could be as shown in Figure 5-3. In this case, the system has insufficient dynamic gain. Turn the PROPORTIONAL potentiometer clockwise to obtain a waveform without oscillation.

Figure 5-3 Waveform resulting from insufficient proportional gain

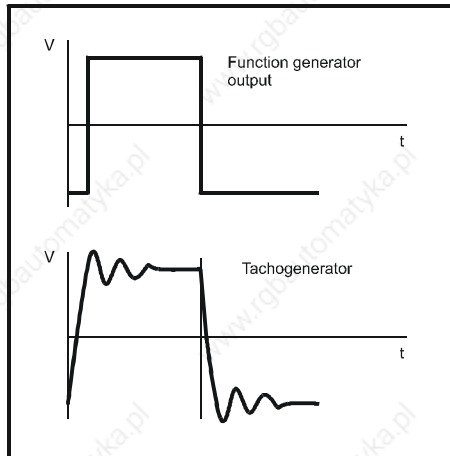

12. When a waveform without oscillation has been obtained, in most cases the response will have an overshoot as shown in Figure 5-4. In this case, the system has insufficient derivative action. Turn the DERIVATIVE potentiometer clockwise to eliminate the overshoot as shown in Figure 5-5.

Figure 5-4 Waveform resulting from insufficient derivative gain

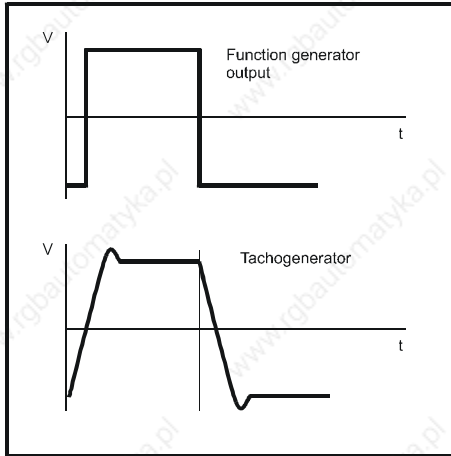

Figure 5-5 Ideal waveform

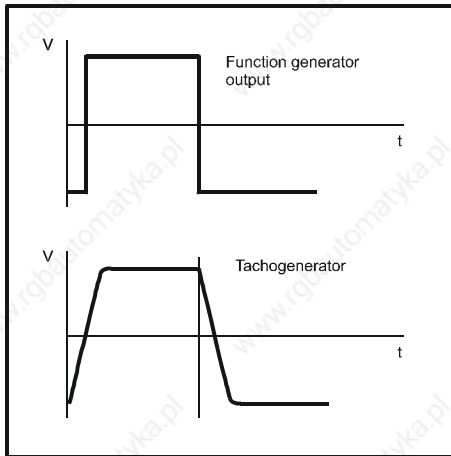
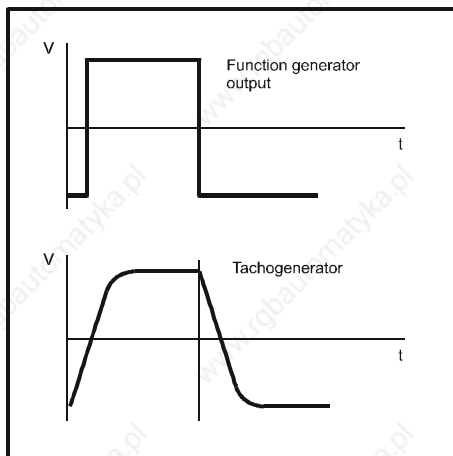

Figure 5-6 Waveform resulting from excessive derivative gain



NOTE It may be necessary to adjust repetitively the PROPORTIONAL and DERIVATIVE potentiometers. If the drive has instability problems after adjustment and when it is connected to a position controller, refer to *section 5.7 Commissioning* on page 54 and Chapter 6 *Diagnostics* on page 56.

5.6 Making adjustments to the Maxi-Maestro drive

5.6.1 Zero speed offset

ZERO REF potentiometer

1. Connect the non-inverting speed reference signal input to pin 9 and the inverting input to pin 10.
2. Set the speed reference signal for zero speed.
3. Remove the connection from pin 15 (STOP signal).
4. Connect a digital multi meter to pins 11 and 12.
5. Enable the drive and adjust the ZERO REF potentiometer to reduce the multi meter reading to not more than 1mV.
6. Restore the original wiring.

If the motor is creeping with a zero speed reference, or when a stop command is applied, please contact the supplier of the drive.

5.6.2 Maximum speed

RT resistor

Use the following equation to calculate the value of the RT resistor:

$$RT = 200[(V_m \times K_{e_{tacho}}) - 5]$$

Sort this equation out, in the same way as the others:

Where:

V_m = Maximum speed of motor in RPM / 1000

$K_{e_{tacho}}$ = Tachogenerator voltage constant

Resistor ratings:

Power: 0.25W

Tolerance: $\pm 5\%$

NOTE

If the calculated value of RT is zero, it is necessary to fit a link instead of a resistor. If the calculated value is negative, the tachogenerator must be changed for one with a greater value of $K_{e_{tacho}}$ in order for the motor to reach the required speed.

Example 1

Max required speed = 3000 RPM

Tachogenerator output = 7V at 1000 RPM

1. Calculate:

$$RT = 200[(3 \times 7) - 5] = 3.2k\Omega$$

The value of the RT resistor must be between 2.7kW and 3.9kW.

2. Fit the resistor.
3. Apply a 2V to 10V speed reference signal between pins 9 and 10. (To generate this signal, use the external controller or the reference voltage output on pins 6 and 7).
4. Measure the reference signal applied to pins 9 and 10 and calculate the tachogenerator output value using the following equation:

$$V_{dt} = \frac{RPM \times V_{ref} \times K_{e_{tacho}}}{10,000}$$

| | | | | | | |
|--------------------|---------------------|-------------------------|-------------------------|---------------------|-------------|---------------|
| Safety Information | Product Information | Mechanical Installation | Electrical Installation | Optimisation | Diagnostics | Miscellaneous |
|--------------------|---------------------|-------------------------|-------------------------|---------------------|-------------|---------------|

Where:

RPM = Maximum required speed

Vref = Measured reference signal

Ke_{tacho} = Tachogenerator voltage constant

Example 2

Max required speed = 3000 RPM

Vref = 5V

Ke_{tacho} = 10 (10V at 1000 RPM)

$$\mathbf{Vdt} = \frac{\mathbf{3000 \times 5 \times 10}}{\mathbf{10,000}} = \mathbf{15V}$$

Measure the tachogenerator output voltage with a digital multimeter, and adjust the maximum speed for the multimeter to show the calculated value. Calibration should be optimized using a speed indicator.

5.6.3 Adjusting the nominal current

When the nominal current rating of the motor is less than the nominal current of the drive, it is possible to reduce the maximum value of current produced by the drive by fitting a RIN resistor.

1. Use the following equation to calculate the value of the RIN resistor:

$$\mathbf{RIN} = \frac{\mathbf{10,000 \times I_{NOM}}}{\mathbf{I_{PEAK} - 2I_{NOM}}}$$

Where:

I_{NOM} = nominal desired current value

I_{PEAK} = Drive peak current value

NOTE

I_{PEAK} is a threshold level which is $2 \times I_{NOM}$ output current of the drive.

When the required nominal current is reduced, the resulting **I_{PEAK}** current may be more than $2 \times I_{NOM}$ before the I^2t protection reduces the peak current to the nominal value. In this case, the peak current is supplied for less than 2 seconds. Added protection is required to stop the **I_{PEAK}** value increasing to more than $2 \times I_{NOM}$. See *section 5.6.4 Adjusting the peak current* on page 49.

When **I_{NOM}** is the theoretical nominal current, and the denominator equals zero, RIN should be open circuit.

Example 3

To calculate a value for RIN for the Model 200 × 25/50 with a 15A nominal current.

$$RIN = \frac{|10,000 \times 15|}{50 - |2 \times 15|} = 7,500\Omega$$

Where:

15 is the requested nominal current

50 is the theoretical peak current of the drive

The following table may be used for finding an approximate value of I_{NOM} .

| RIN | Maxi-Maestro 200 × 25/50 or 100 × 25/50 |
|------|--|
| kΩ | I_{NOM} |
| | 25 |
| 56.0 | 23 |
| 57.0 | 21 |
| 15.0 | 19 |
| 10.0 | 17 |
| 7.5 | 15 |
| 5.6 | 13 |
| 3.9 | 11 |
| 2.7 | 9 |

5.6.4 Adjusting the peak current

RIP resistor

When a RIN resistor is fitted, I_{PEAK} may become excessively high in relation to I_{NOM} . To reduce the value of the peak current, use an RIP resistor.

NOTE The new value for I_{PEAK} must be ignored when the value of RIN is calculated.

Use the following equation to calculate the value of the RIP resistor:

$$RIP = \frac{|10 \times I_{LIM}|}{|I_{PEAK} - 1 I_{LIM}|} k\Omega$$

Where:

I_{LIM} = the new value required for I_{PEAK}

NOTE When the peak current is reduced, the ratio between I_{PEAK} and I_{NOM} is altered. This alteration increases the time before I^2t protection takes place. In this case, the peak current is supplied for more than 2 seconds.

The following table may be used for finding an approximate value of I_{PEAK} .

| RIP kΩ | Maxi-Maestro 200 × 25/50 or 100 × 25/50 |
|-----------|--|
| | I_{PEAK} |
| | 50 |
| 220.0 | 48 |
| 120.0 | 46 |
| 75.0 | 44 |
| 56.0 | 42 |
| 39.0 | 40 |
| 32.0 | 38 |
| 27.0 | 36 |
| 22.0 | 34 |
| 18.0 | 32 |

5.6.5 Adjusting tacho loss protection

RRT resistor

1. Set Switch 3 at ON to enable tacho loss protection.
2. Use the following equation to calculate the correct value for the RRT resistor:

$$RRT = [(0.0424 \times V_m \times K_{e_{motor}}) - 1] \times 183000$$

Where:

V_m = Maximum speed in RPM/1000

$K_{e_{motor}}$ = Motor voltage constant (voltage at 1000 RPM - in general V x 1000/RPM)

Example 4

Max speed = 3000 RPM

V_m = 3

Motor voltage constant (at 1000 RPM) $K_{e_{motor}} = 15$

$$RRT = [(0.0424 \times 3 \times 15) - 1] \times 183000 = 166164\Omega$$

5.6.6 Adjusting speed for operation in armature feedback mode

RKW resistor

Armature feedback mode can be used when a tachogenerator is not fitted to the motor. Speed control is then less precise. Speed is controlled by using the motor voltage as feedback.

Voltage drop due to motor resistance can be compensated by adjusting the value of the RAI resistor.

1. Set Switch 1/2 at OFF to enable operation with armature feedback.
2. Set Switch 3 at OFF to disable tachogenerator loss protection.
3. Use the following equation to calculate the correct value of RKW resistor:

$$RKW = 77.7 \times V_m \times K_{e_{motor}}$$

Where:

V_m = Maximum speed in RPM/1000

K_e_{motor} = Motor voltage constant (voltage at 1000 RPM - in general V x 1000/RPM)

4. Calculating the value of the RAI resistor can be difficult since it is a function of the following:

- Motor characteristics. (eg. armature resistance and temperature).
- Brush resistance (changing with wear).

An approximate value may be found experimentally using a RAI resistor value of 400kΩ to 600kΩ.



Too low a value for the RAI resistor may modify the velocity loop response. For guidance, contact Control Techniques.

5.6.7 Zero speed torque

RS resistor

No resistor is fitted as standard. Mount an RS resistor to adjust the amount of torque current to be applied to the motor when the drive has received a STOP command.

The RS resistor value is a function of the following:

- Motor characteristics (e.g. armature resistance and temperature)
- Brush resistance (changing with wear)

To achieve an accurate value, it is advisable to carry out a simple test by fitting a 2.2MΩ potentiometer in the RS location, enable the Drive and set the potentiometer to reach the required torque level. It is recommended that when the value of RS is established, you replace the potentiometer with a conventional resistor.

5.6.8 Dynamic calibration

For modifying the setting, the following equipment is required:

Low frequency function generator

Frequency range: 0Hz to 10MHz

Output voltage: -3.5V to +3.5V

Twin-trace storage oscilloscope.

1. Remove the speed reference signal from pins 9 and 10.
2. Connect the function generator output to pins 9 and 10.
3. Set the function generator at the following:
 - Square wave output
 - Amplitude: ±2V
 - Frequency: 0.2Hz
4. Connect oscilloscope channel A to pin 11.
5. Connect oscilloscope channel B to pin 1.
6. Connect oscilloscope ground to pin 8.
7. Connect the oscilloscope external trigger input to the function generator output.

8. Set the oscilloscope as follows:
 - Sensitivity: 1mV per division
 - Timebase: 20ms per division



When the motor load is a slide with limited travel, avoid the slide activating the limit switches by increasing the reference signal frequency or decreasing the reference signal amplitude in order to reduce the speed.

NOTE

When the peak current is reduced, the ratio between I_{PEAK} and I_{NOM} is altered. This alteration increases the time before I^2t protection takes place. In this case, the peak current is supplied for more than 2 seconds.

The minimum acceptable amplitude for the reference signal is 1V peak to peak.

9. Apply power to the drive.
10. Enable the drive.
11. The waveform could be as shown in Figure 5-7. In this case, the system has insufficient dynamic gain. Turn the PROPORTIONAL potentiometer clockwise to obtain a waveform without oscillation.

Figure 5-7 Waveform resulting from insufficient proportional gain

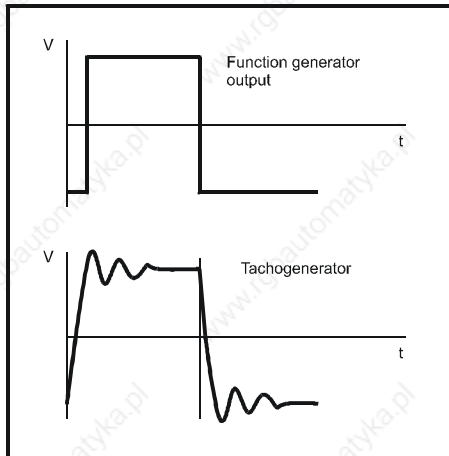

12. When a waveform without oscillation has been obtained, in most cases the response will have an overshoot as shown in Figure 5-8. In this case, the system has insufficient derivative action. Turn the DERIVATIVE potentiometer clockwise to eliminate the overshoot as shown in Figure 5-9.

Figure 5-8 Waveform resulting from insufficient derivative gain

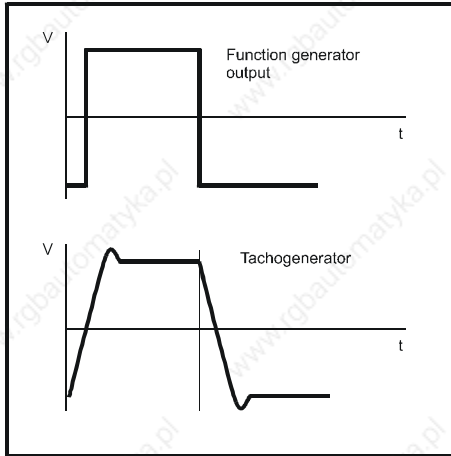

Figure 5-9 Ideal waveform

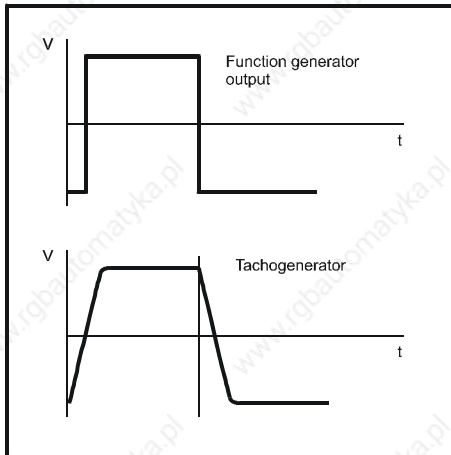
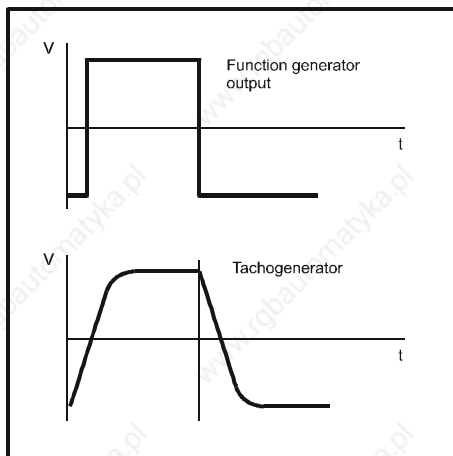

Figure 5-10 Waveform resulting from excessive derivative gain



NOTE It may be necessary to adjust repetitively the PROPORTIONAL and DERIVATIVE potentiometers.
If the drive has instability problems after adjustment and when it is connected to a position controller, refer to *section 5.7 Commissioning* on page 54 and Chapter 6 *Diagnostics* on page 56.

5.7 Commissioning

5.7.1 Preliminary checks

1. Check that the correct values of components have been used. Check the components are correctly fitted.
2. Check the three cables from the transformer secondary winding to pins 21, 22, 23 are correct. Check that the terminals are tight.
3. Check the polarity of the tachogenerator and the motor.

NOTE When a position speed reference is applied to pin 10, the output voltage on pin 17 is positive. When this is connected to the positive input of the motor, the motor turns clockwise as seen from the flange.
To reverse the motor direction, reverse the motor and tachogenerator connections.

5.7.2 Initial start up

1. Disconnect the signal connector from the drive.
2. When a multi-axis system is to be powered up, remove the AC supply fuses for all the drives except for the drive to be tested.
3. Apply power to the connected drive. After a delay of about 1 second, the green LED will light.
4. Check that the motor is free to turn by hand.

| | | | | | | |
|--------------------|---------------------|-------------------------|-------------------------|---------------------|-------------|---------------|
| Safety Information | Product Information | Mechanical Installation | Electrical Installation | Optimisation | Diagnostics | Miscellaneous |
|--------------------|---------------------|-------------------------|-------------------------|---------------------|-------------|---------------|

5. Check that there is no current flowing through the motor.
6. Check that the green LED stays on.
7. Switch off the drive.
8. Repeat instructions 1 to 7 for all other axes.



WARNING

After switching off, wait for about 10 seconds before re-applying power to the drives in order to avoid loss of protection in the drives already powered.



WARNING

The next instruction requires the drive to be powered up. Any incorrect wiring to the motor may result in the motor turning at high speed and in the wrong direction. During these operations the load must be disconnected and the operator must be able to turn the system off quickly.

1. Check that the speed reference signal is zero volts.
2. Connect the signal connector to the first drive. Switch on the drive.
3. Check that the motor does not rotate.
4. Enable the drive.
5. Check that the motor is stationary or turns slowly due to a signal offset.
6. Apply a signal to the STOP input.
7. Try to force the motor shaft to turn in both directions and check torque is applied at zero speed. This checks that there is symmetric torque generation.
8. Alter the reference signal for the motor to turn clockwise or anti-clockwise. Note that the motor may turn extremely slowly. If the motor rotates in the reverse direction to the expected one, reverse the motor and tachogenerator connections.
9. Repeat operations 1 to 8 for all the other axes.
10. Leave the system powered up for at least 15 minutes in normal working conditions.

Check the I^2t protection LED is off and the green drive normal LED is on.

If the system does not run as described during start-up, refer to section 6.3 *Fault finding* on page 57.

6 Diagnostics

Four LEDs and two digital outputs are available on the drive to give the following:

Monitoring the status of the drive

Diagnostics

I²t protection

6.1 LED indicators

6.1.1 I²t protection indicator

The I²t LED is lit when I²t exceeds the programmed value, which is set by the RIN resistor. (See section 5.1 *Setting up the drive* on page 35).

When the I²t LED is lit, the drive is limited to the value of nominal current set by the RIN resistor. (See section 5.1 *Setting up the drive* on page 35).

I²t protection can be caused by:

A heavy working cycle with quick and frequent accelerations

Reversal of the drive

Drive rating inadequate.

When I²t limiting is not activated, the green LED will light and a **Drive NORMAL** output signal will be produced.

6.1.2 Tachogenerator loss-detection indicator

The **TACHO LOSS** LED is lit when one of the following occurs:

- Tachogenerator open or short circuit
- Cable connections short circuit
- Polarity of tachogenerator connections incorrect
- Tachogenerator not connected

6.1.3 DRIVE NORMAL indicator

The **DRIVE NORMAL** LED indicates that the drive is operating normally. When the LED is unlit it indicates at least one of the drive protection functions is active.

6.1.4 BR fault indicator

(Maxi-Maestro only)

The **BR FAULT** LED is positioned below the power connector. The **BR FAULT** LED is lit when the braking resistor is short circuit, or when a braking resistor having too low a value is fitted.

| | | | | | | |
|--------------------|---------------------|-------------------------|-------------------------|--------------|--------------------|---------------|
| Safety Information | Product Information | Mechanical Installation | Electrical Installation | Optimisation | Diagnostics | Miscellaneous |
|--------------------|---------------------|-------------------------|-------------------------|--------------|--------------------|---------------|

6.2 Outputs

6.2.1 I²t output

Pin 4

A signal is produced on this output during I²t limiting, and the I²t LED is lit. Maximum voltage available is 47V. Drive capability when no signal is given is 100mA.

6.2.2 DRIVE NORMAL output

Pins 13 and 14

When the drive is working normally, (i.e. Green /Drive Healthy LED is lit), pins 13 and 14 are internally connected together. When a protection becomes active, pins 13 and 14 are disconnected.

This signal may be used to power a remote control switch. The contact rating is 30V, 5A AC.

6.3 Fault finding

Use the following procedures when the system is not working correctly after calibration.

6.3.1 Green LED off

Power supply voltage out of range

Verify voltage level. (Refer to Chapter 2 *Product Information* on page 3).

Switch-off / switch-on sequence too fast

Switch off the system for at least one minute before re-applying AC power.

Drive protection is activated

Look for a short circuit between the power connector terminals.

Voltage from a motor cable or choke terminal, short circuit to ground

Remove the motor cables from pins 17 and 18 of the power connector, switch on the drive and if the green LED is now lit, check the cables.

6.3.2 Braking resistor overheating or BR LED is lit

Fault in the braking resistor circuit

This symptom may occur when the signal connector is not inserted. Check the power supply voltage is not excessive.

Heavy working cycle

Increase the acceleration and deceleration time, or fit an external braking resistor.

Braking resistor is short circuit

Ensure the braking resistor connections are correct. (Refer to Chapter 4 *Electrical Installation* on page 14).

Value for the resistor too low

Ensure the correct value for the resistor is being used. (Refer to Chapter 4 *Electrical Installation* on page 14).

| | | | | | | |
|--------------------|---------------------|-------------------------|-------------------------|--------------|--------------------|---------------|
| Safety Information | Product Information | Mechanical Installation | Electrical Installation | Optimisation | Diagnostics | Miscellaneous |
|--------------------|---------------------|-------------------------|-------------------------|--------------|--------------------|---------------|

6.3.3 Motor not in full control

Tachogenerator cables reversed

Reverse the tachogenerator cables.

Motor cables reversed

Reverse the motor cables.

No tachogenerator signal on pins 11 and 12

Check the tachogenerator and the tachogenerator cables.

RT resistor not fitted on daughter board

Calculate the correct value for the RT resistor see section 5.1 *Setting up the drive* on page 35 to adjust the components.

Speed reference signal on input pins 9 and 10

Reduce the speed reference signal to less than 1mV.

6.3.4 Motor turns in reverse direction

Speed reference signal pins 9 and 10 reversed

Reverse pins 9 and 10.

Motor connections pins reversed

Reverse pins 17 and 18.

Tachogenerator connection pins reversed

Reverse pins 11 and 12.

6.3.5 Tacho loss protection when operating in armature feedback

Switch 3 set at ON

Set switch 3 at OFF.

6.3.6 Difficulty in adjusting system dynamic response

Components on the daughter board have been selected for a non-selected function

If the tachogenerator feedback mode has been selected, the resistors RAI and RKW must be disconnected.

RS resistor selected to improve STOP condition

When a RS resistor is fitted, the dynamic response is modified. If this resistor is not required, disconnect it.

6.3.7 Asymmetric torque generation

Drive is affected by signal noise

When output pins 6 and 7 (voltage reference outputs) are connected with long cables, it may be necessary to install 0.1mF capacitors as follows:

Between pin 6 and pin 8

Between pin 7 and pin 8

7 Miscellaneous

7.1 Alternative daughter boards

If the drive is relatively old, it is possible that the following alternative daughter boards may be fitted. The switching arrangements are as follows:

Figure 7-1 Alternative daughter board 1

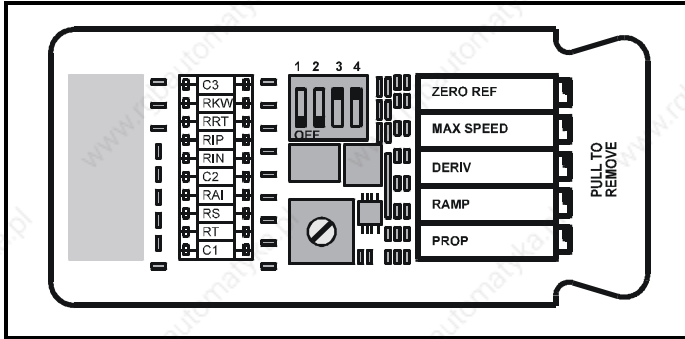

The standard switch settings are as follows:

| | |
|-----------------|-----|
| Switch 1 | OFF |
| Switch 2 | OFF |
| Switch 3 | ON |
| Switch 4 | ON |

Switch 1

| | |
|------------|--------------------------------------|
| ON | Enables armature feedback function. |
| OFF | Disables armature feedback function. |

Switch 2

| | |
|------------|---------------------------------|
| ON | Enables tacho loss protection. |
| OFF | Disables tacho loss protection. |

Switch 3

| | |
|------------|---|
| ON | Enables speed control with tachogenerator feedback. When used in this position remove RAI resistor. |
| OFF | Disables speed control with tachogenerator feedback. |

Switch 4

| | |
|------------|--|
| ON | Disables acceleration and deceleration ramp. |
| OFF | Enables acceleration and deceleration ramp. |

Figure 7-2 Alternative daughter board 2

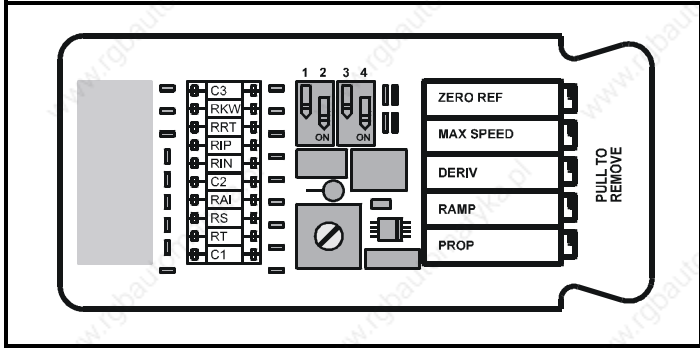

The standard switch settings are as follows:

| | |
|-----------------|-----|
| Switch 1 | OFF |
| Switch 2 | ON |
| Switch 3 | OFF |
| Switch 4 | ON |

Switch 1

| | |
|------------|--------------------------------------|
| ON | Enables armature feedback function. |
| OFF | Disables armature feedback function. |

Switch 2

| | |
|------------|---|
| ON | Enables speed control with tachogenerator feedback. When used in this position remove RAI resistor. |
| OFF | Disables speed control with tachogenerator feedback. |

Switch 3

| | |
|------------|---------------------------------|
| ON | Enables tacho loss protection. |
| OFF | Disables tacho loss protection. |

Switch 4

| | |
|------------|--|
| ON | Disables acceleration and deceleration ramp. |
| OFF | Enables acceleration and deceleration ramp. |

Index

A

| | |
|------------------------------------|---|
| AC supply | 4 |
| Ambient temperature | 3 |
| Analog speed reference input | 3 |
| Armature feedback | 3 |

B

| | |
|---|------------------------|
| Braking resistor | 12, 24 |
| Calculations | 29 |
| Connections | 27 |
| Current setting for a thermal overload protection relay | 32 |
| External braking resistor | 12, 24, 25, 26, 27, 28 |
| Internal braking resistor | 24, 27 |
| Minimum permissible deceleration time | 29 |
| Power rating | 30 |
| Precautions | 26 |
| Resulting torque | 30 |
| Thermal protection | 26 |
| Value | 32 |

C

| | |
|-------------------------------------|--------|
| Cautions | 1 |
| Choke | 11, 21 |
| Commissioning | 54 |
| Current | |
| Adjusting the nominal current | 40, 48 |
| Adjusting the peak current | 41, 49 |
| Current tolerance | 5 |

D

| | |
|-----------------------------------|--------|
| Daughter boards | 7, 35 |
| Alternative daughter boards | 59, 60 |
| DC bus supply voltage | 20 |
| Diagnostics | 56 |
| Drive dimensions | 6 |
| Dynamic calibration | 43, 51 |

E

| | |
|-------------------------------|----|
| Electrical installation | 14 |
| Electrical safety | 1 |

F

| | |
|---|---|
| Features of Midi and Maxi Maestro | 3 |
|---|---|

G

| | |
|--------------------------|--------|
| Ground connections | 20, 22 |
|--------------------------|--------|

M

Maxi-Maestro adjustments

| | |
|---|----|
| Dynamic calibration | 51 |
| Maximum speed | 47 |
| Nominal current | 48 |
| Peak current | 49 |
| RIP resistor | 49 |
| RKW resistor | 50 |
| RRT resistor | 50 |
| RS resistor | 51 |
| RT resistor | 47 |
| Speed for operation in armature feedback mode | 50 |
| Tacho loss protection | 50 |
| ZERO REF potentiometer | 47 |
| Zero speed offset | 47 |
| Zero speed torque | 51 |

Mechanical installation

8

Midi-Maestro adjustments

| | |
|---|----|
| Dynamic calibration | 43 |
| Maximum speed | 39 |
| Nominal current | 40 |
| Peak current | 41 |
| RIP resistor | 41 |
| RKW resistor | 42 |
| RRT resistor | 42 |
| RS resistor | 43 |
| RT resistor | 39 |
| Speed for operation in armature feedback mode | 42 |
| Tacho loss protection | 42 |
| ZERO REF potentiometer | 38 |
| Zero speed offset | 38 |
| Zero speed torque | 43 |

Motor connections

20, 21

Mounted components

37

| | |
|--------------------|----|
| C1 capacitor | 38 |
| C2 capacitor | 38 |
| C3 capacitor | 38 |
| RAI resistor | 37 |
| RIN resistor | 37 |
| RIP resistor | 37 |
| RKW resistor | 37 |
| RRT resistor | 37 |
| RS resistor | 37 |
| RT resistor | 38 |

Mounting details

8, 9, 10

N

Notes

1

O

| | |
|----------------------|----|
| Optimisation | 35 |
| Output current | 4 |

P

Potentiometer

| | |
|----------------------|----|
| Derivative | 36 |
| Maximum speed | 35 |
| Proportional | 36 |
| Ramp | 36 |
| Zero reference | 35 |

| | |
|----------------------|--------|
| Potentiometers | 35, 36 |
|----------------------|--------|

| | |
|--------------------|---|
| Power cables | 4 |
|--------------------|---|

| | |
|-------------------------|------------|
| Power connections | 14, 15, 16 |
|-------------------------|------------|

| | |
|------------------|---|
| Protection | 6 |
|------------------|---|

S

| | |
|--------------------------|---|
| Safety information | 1 |
|--------------------------|---|

| | |
|---------------------------|---|
| Safety of personnel | 2 |
|---------------------------|---|

| | |
|--------------------------|--------|
| Signal connections | 14, 15 |
|--------------------------|--------|

| | |
|---------------------|---|
| Signal wiring | 4 |
|---------------------|---|

| | |
|------------------------|----------------|
| Speed adjustment | 39, 42, 47, 50 |
|------------------------|----------------|

| | |
|--------------------|--------|
| Supply fuses | 19, 20 |
|--------------------|--------|

| | |
|----------------|----|
| Switches | 36 |
|----------------|----|

| | |
|---------------------|---|
| System design | 1 |
|---------------------|---|

T

| | |
|--|--------|
| Tacho loss protection adjustment | 42, 50 |
|--|--------|

| | |
|-------------------------------|---|
| Tachogenerator feedback | 3 |
|-------------------------------|---|

Torque

| | |
|------------------------------------|--------|
| Zero speed torque adjustment | 43, 51 |
|------------------------------------|--------|

Transformer power rating

| | |
|--------------------|----|
| Single phase | 18 |
|--------------------|----|

| | |
|-------------------|----|
| Three phase | 17 |
|-------------------|----|

V

| | |
|-------------------|----|
| Ventilation | 13 |
|-------------------|----|

W

| | |
|----------------|---|
| Warnings | 1 |
|----------------|---|