



506/507/508

Product Manual

HA389427 Issue 10

WARRANTY

Parker SSD Drives warrants the goods against defects in design, materials and workmanship for the period of 12 months from the date of delivery on the terms detailed in Parker SSD Drives Standard Conditions of Sale IA058393C.

Parker SSD Drives reserves the right to change the content and product specification without notice.

© Copyright 2007 Parker SSD Drives, a division of Parker Hannifin Ltd.

All rights strictly reserved. No part of this document may be stored in a retrieval system, or transmitted in any form or by any means to persons not employed by a Parker SSD Drives company without written permission from Parker SSD Drives, a division of Parker Hannifin Ltd. Although every effort has been taken to ensure the accuracy of this document it may be necessary, without notice, to make amendments or correct omissions. Parker SSD Drives cannot accept responsibility for damage, injury, or expenses resulting therefrom.

Safety Information



Requirements

IMPORTANT: Please read this information **BEFORE** installing the equipment.

Intended Users

This manual is to be made available to all persons who are required to install, configure or service equipment described herein, or any other associated operation.

The information given is intended to highlight safety issues, EMC considerations, and to enable the user to obtain maximum benefit from the equipment.

Complete the following table for future reference detailing how the unit is to be installed and used.

INSTALLATION DETAILS	
Model Number <i>(see product label)</i>	
Where installed <i>(for your own information)</i>	
Unit used as a: <i>(refer to Certification for the Inverter)</i>	<input type="checkbox"/> Component Apparatus <input type="checkbox"/> Relevant
Unit fitted:	<input type="checkbox"/> Wall-mounted <input type="checkbox"/> Enclosure

Application Area

The equipment described is intended for industrial motor speed control utilising AC induction or AC synchronous machines.

Personnel

Installation, operation and maintenance of the equipment should be carried out by qualified personnel. A qualified person is someone who is technically competent and familiar with all safety information and established safety practices; with the installation process, operation and maintenance of this equipment; and with all the hazards involved.

Safety Information



Product Warnings

	Caution Risk of electric shock		Caution Refer to documentation		Earth/Ground Protective Conductor Terminal
--	--	--	--	--	--

Hazards

DANGER! - Ignoring the following may result in injury

1. This equipment can endanger life by exposure to rotating machinery and high voltages.
2. The equipment must be permanently earthed due to the high earth leakage current, and the drive motor must be connected to an appropriate safety earth.
3. Ensure all incoming supplies are isolated before working on the equipment. Be aware that there may be more than one supply connection to the drive.
4. There may still be dangerous voltages present at power terminals (motor output, supply input phases, DC bus and the brake, where fitted) when the motor is at standstill or is stopped.
5. For measurements use only a meter to IEC 61010 (CAT III or higher). Always begin using the highest range. CAT I and CAT II meters must not be used on this product.
6. Allow at least 5 minutes for the drive's capacitors to discharge to safe voltage levels (<50V). Use the specified meter capable of measuring up to 1000V dc & ac rms to confirm that less than 50V is present between all power terminals and earth.
7. Unless otherwise stated, this product must NOT be dismantled. In the event of a fault the drive must be returned. Refer to "Routine Maintenance and Repair".

Safety Information



WARNING! - Ignoring the following may result in injury or damage to equipment

SAFETY

Where there is conflict between EMC and Safety requirements, personnel safety shall always take precedence.

- Never perform high voltage resistance checks on the wiring without first disconnecting the drive from the circuit being tested.
- Whilst ensuring ventilation is sufficient, provide guarding and /or additional safety systems to prevent injury or damage to equipment.
- When replacing a drive in an application and before returning to use, it is essential that all user defined parameters for the product's operation are correctly installed.
- All control and signal terminals are SELV, i.e. protected by double insulation. Ensure all external wiring is rated for the highest system voltage.
- Thermal sensors contained within the motor must have at least basic insulation.
- All exposed metalwork in the Inverter is protected by basic insulation and bonded to a safety earth.
- RCDs are not recommended for use with this product but, where their use is mandatory, only Type B RCDs should be used.

EMC

- In a domestic environment this product may cause radio interference in which case supplementary mitigation measures may be required.
- This equipment contains electrostatic discharge (ESD) sensitive parts. Observe static control precautions when handling, installing and servicing this product.
- This is a product of the restricted sales distribution class according to IEC 61800-3. It is designated as "professional equipment" as defined in EN61000-3-2. Permission of the supply authority shall be obtained before connection to the low voltage supply.

Safety Information



CAUTION!

APPLICATION RISK

- The specifications, processes and circuitry described herein are for guidance only and may need to be adapted to the user's specific application. We can not guarantee the suitability of the equipment described in this Manual for individual applications.

RISK ASSESSMENT

Under fault conditions, power loss or unintended operating conditions, the drive may not operate as intended.

In particular:

- Stored energy might not discharge to safe levels as quickly as suggested, and can still be present even though the drive appears to be switched off
- The motor's direction of rotation might not be controlled
- The motor speed might not be controlled
- The motor might be energised

A drive is a component within a drive system that may influence its operation or effects under a fault condition.

Consideration must be given to:

- Stored energy
- Supply disconnects
- Sequencing logic
- Unintended operation

Contents

	<i>Contents</i>	<i>Page</i>
Chapter 1	PRODUCT OVERVIEW	
	Description	1-1
	Product Range	1-1
Chapter 2	OVERVIEW OF THE 506/507/508	
	• <i>User Supplied Primary Components</i>	2-1
	• <i>Optional Ancillary Components</i>	2-1
Chapter 3	TERMINAL DESCRIPTION	
	Control Terminals	3-1
	Power Terminals	3-2
	Auxiliary Terminals.....	3-2
	Switches.....	3-3
	Potentiometers	3-3
	LEDS	3-3
Chapter 4	INSTALLING THE 506/507/508	
	Installation	4-1
	Speed Control.....	4-1
	Current Control	4-1
	Wire Sizes.....	4-2
	Requirements for UL Compliance	4-3
	Motor Overload Protection	4-3
	Short Circuit Protection Requirements	4-3
	Short Circuit Rating	4-3
	Operating Ambient Temperature	4-3
	Field Wiring Temperature Rating	4-3
	Field Wiring Terminal Markings	4-3
	Power Wiring Terminals.....	4-3
	Block Diagram	4-4
	Terminal Tightening Torque.....	4-6
	Field Grounding Terminals	4-6
	Fitting	4-6
	Removing the Cover	4-7
	Filter	4-8
	EMC Connections	4-9

Contents

	<i>Contents</i>	<i>Page</i>
	Installation and Set-Up	4-9
	Warning	4-9
	Switch Selection.....	4-9
	Potentiometer.....	4-10
	Motor	4-10
	Wiring	4-10
	Applying Power	4-10
	Fault Finding.....	4-12
Chapter 5	ROUTINE MAINTENANCE AND REPAIR	
	Routine Maintenance.....	5-1
	Repair	5-1
	Returning the Unit to Parker SSD Drives.....	5-1
Chapter 6	CERTIFICATION FOR THE 506/507/508	
	Certificates	6-2
Chapter 7	TECHNICAL SPECIFICATION	
	Input Supply.....	7-1
	Speed Control.....	7-1
	Current (Torque) Control	7-1
	Adjustment Range	7-2
	Environmental Requirements.....	7-2
	EMC Technical Ratings	7-3
	• Immunity.....	7-3
	• Emissions.....	7-3
	Electrical Ratings	7-4
	Output Ratings with typical armature voltage, V_a , 80/90V (160/180V).....	7-4
	Adjustment Ranges.....	7-4
	Product Code.....	7-5

PRODUCT OVERVIEW

Description

The 506/507/508 series controllers are compact, non-isolated motor speed controllers specifically designed for dc shunt wound and permanent magnet motors. The controllers are intended to operate from a single phase AC mains supply in the ranges 110/120V AC or 220/240V AC 50/60Hz.

The controllers are intended to be mounted on a length of DIN rail in an enclosure.

Control of the associated DC motor is achieved by using a linear closed loop feedback signal based on the motor's own DC armature voltage. This enables constant motor speed to be maintained throughout variable motor loads. Improved speed measurement can be obtained by using a tacho-generator, connected to the motor's shaft, to provide the feedback signal.

A current loop within the speed feedback path ensures that safe current levels are always provided to the armature of the motor up to the level set by the maximum current potentiometer (I_{max}). This adjustment is linear and switchable to a lower range of half the controller current.

If the controlled motor is stalled (e.g. due to either a faulty field circuit or an excessive load), then a stall timer will remove current from the motor after approximately 15 seconds. Severe armature current overloads, are protected against by an instantaneous over-current trip.

The controllers may also be used in a linear motor torque mode by using an adjustable setpoint. In this mode of operation over-speed limiting is a standard feature.

Product Range

Product	Rating	Adjustment Standard	Switched
506	3A DC Full Load Current	0.5 to 3A	0.25 to 1.5A
507	6A DC Full Load Current	1 to 6A	0.5 to 3A
508	12A DC Full Load Current	2 to 12A	1 to 6A

1-2 Product Overview

OVERVIEW OF THE 506/507/508

Figure 2.1 Recognition Drawing

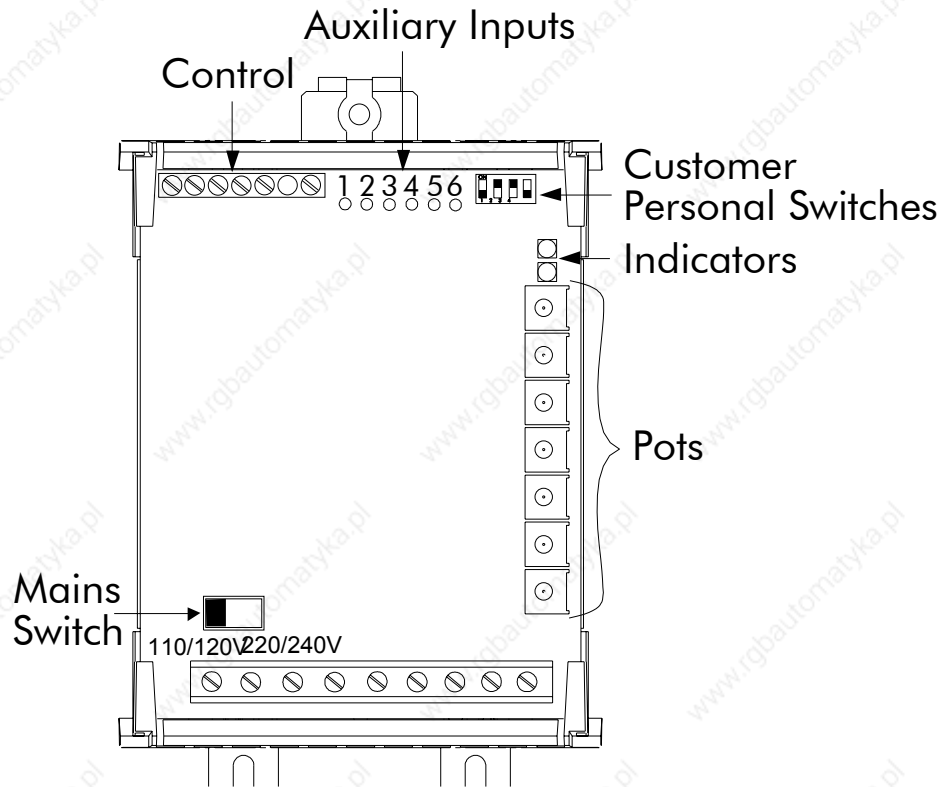

User Supplied Safety Components

Speed /

Torque Potentiometer 10K Isolated spindle and insulating knob

Switch

Rated for input supply voltage.

Note: Safety Components provide Isolation for the User. These components should be selected to provide a double insulated (or reinforced) isolation boards for the user suitable for the input supply voltage used. The product is designed for use in a pollution degree 2 environment, overvoltage category III, enclosure mounted. (Refer to EN61010, IEC664 or EN50178 for more information regarding the correct selection of these components).

Optional Ancillary Components

EMC Filter 18A ac(12A dc) CO389115

2-2 Overview of the 506/507/508

TERMINAL DESCRIPTION

Control Terminals			
Terminal	Function	Description	Notes
1	Tacho Feedback	Motor Mounted Tachogenerator Input Terminal.	200V dc Max.
2	0V-Signal Common	Control Signal Reference.	Must NOT be Earthed (Grounded).
3	Run	Digital Input to Enable Controller. Connect to 0V to Run in Speed. Connect to + 10V to Run in Current.	Input Impedance -> 20k Ohm
4	Speed Setpoint	Analogue Input, 0v to +10V = 0 to 100% Speed.	Input Impedance - 66k Ohm
5	+10V Reference	Analogue Output, +10V Reference for Speed and Current Setpoints.	Load - 2mA
6	Current Limit	Analogue Input, 0 to +10V=0 to 100% Current	Input Impedance - 100k Ohm



WARNING!

This is a non-isolated product. The control connections are not isolated from the AC supply. Any connection to earth or use of earth (ground) referenced components either deliberately or unintentionally will cause permanent damage to the controller.

3-2 Terminal Description

Power Terminals

The product may be connected phase - to - phase provided the resultant voltage does not exceed the maximum supply voltage specified.

Terminal	Function	Description	Notes
L1 (L)	AC Input Live	AC Supply Terminal Line 1 or Live	
L2 (N)	AC Input Neutral	AC Supply Terminal Line 2 or Neutral	
F+	Field Positive	Field Output Positive	
F-	Field Negative	Field Output Negative	
A-	Armature Negative	Armature Output Negative	
A+	Armature Positive	Armature Output Positive	
Grd 	Protective Earth (Ground)	Drive Module Protective Earth (Ground)	
Grd 	Protective Earth (Ground)	Motor Protective Earth (Ground)	

Auxiliary Terminals

* The power must be supplied from an independent power supply which is not earth (ground) referenced.

Terminal	Function	Description	Notes
A1	Auxiliary Supply	Auxiliary Relay Supply	+16V at 10mA
A2	0V - Signal Common	Signal Reference	Must not be earthed (grounded)
A3	Zero Speed	Zero Speed Output	24V at 50mA open Collector *
A4	Health	Health Output	24V at 50mA open Collector *
A5	Zero Speed Level	Zero Speed Output Level Trim	For other levels see Table 3.1
A6	Auxiliary Setpoint	Auxiliary Direct Speed Setpoint	+10V @ 100K Full Speed Input

Table 3.1

External Resistor	Terminal Volts at Zero Speed	180V _a	90V _a
--	10.75V	6%	12%
4k7	5.5V	3%	6%
2k2	2.5V	2%	4%
1k	2V	1%	2%

The zero speed detector operates from the Controller Output voltage, the default level is set to 6% of 180V dc.

Switches

Switch	Off	On
SW1	I _{max.} 506 - 0.25 to 1.5A I _{max.} 507 - 0.5 to 3.0A I _{max.} 508 - 1.0 to 6.0A	I _{max.} 506 - 0.5 to 3.0A I _{max.} 507 - 1.0 to 6.0A I _{max.} 508 - 2.0 to 12.0A
SW2	½ Speed Demand	Full Speed Demand
SW3	¼ Speed Feedback	Full Speed Feedback
SW4	Tacho Feedback	Armature Feedback

Potentiometers

P1	RAMP UP	Setpoint ramp adjustment clockwise to increase time.
P2	RAMP DOWN	Setpoint ramp adjustment clockwise to increase time.
P3	SPEED STABILITY	Speed loop stability clockwise increase response.
P4	CURRENT CALIBRATION	Output current calibration clockwise to increase output.
P5	IR COMPENSATION	Speed droop compensation armature voltage feedback.
P6	MINIMUM SPEED	Clockwise to increase compensation. Minimum speed at zero setpoint. (Can also be used as zero speed trim anticlockwise to reduce speed at zero setpoint).
P7	MAXIMUM SPEED	Maximum speed calibration clockwise to increase speed.

LEDS

POWER-ON	Indicates power supply is present on terminals. (Note:- This LED does not indicate that the <u>CORRECT</u> voltage is applied).
HEALTH	When illuminated the controller is unhealthy due to either an overcurrent trip or a stall trip condition. Should normally be "OFF".

3-4 Terminal Description

INSTALLING THE 506/507/508

Installation

Speed Control

Figure 4.1 Wiring Diagram Speed Control

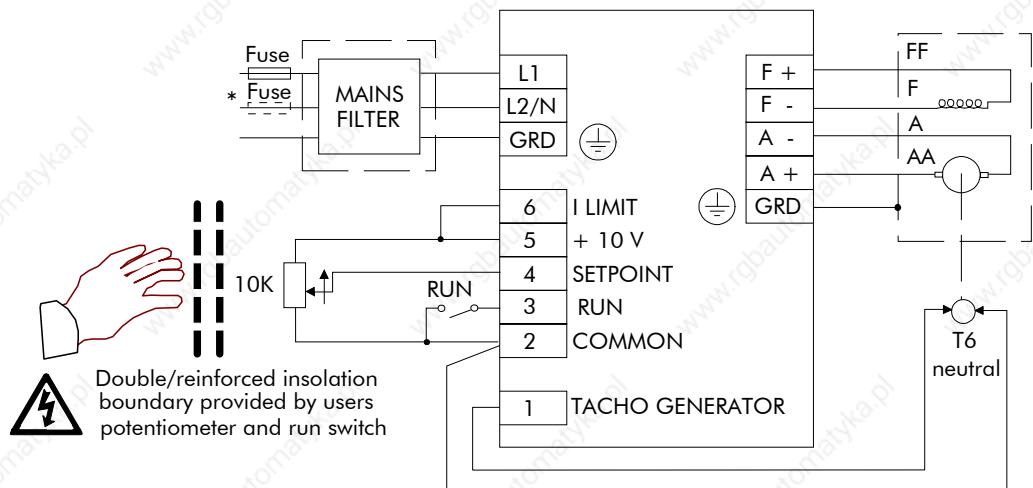

- * Additional line fuse recommended for applications where live connections are made rather than live and neutral.

'Run' connects to Common to 'Enable' Speed Control.

Current Control

Figure 4.2 Wiring Diagram Current Control

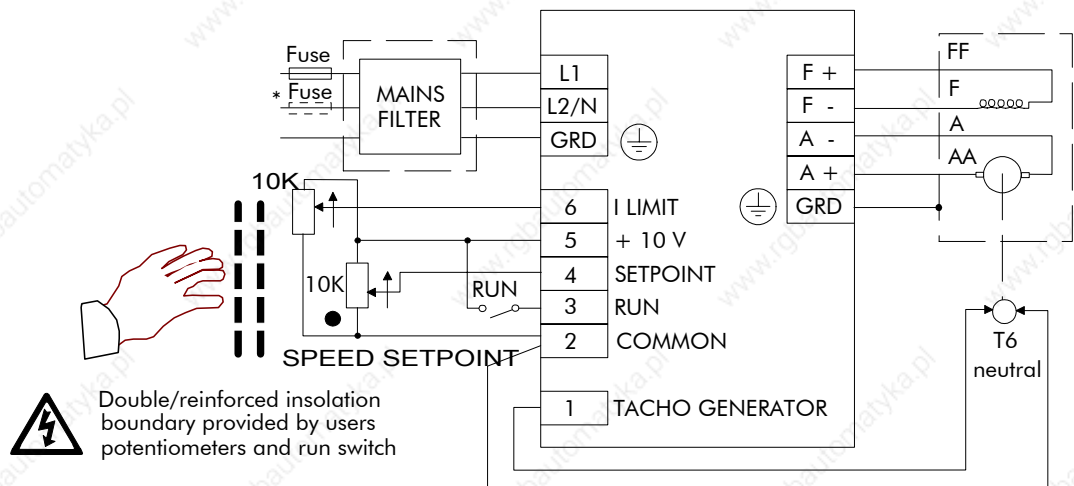

- Optional Speed Setpoint potentiometer to limit overspeed, connect setpoint direct to +10V if not required.

- * Additional line fuse recommended for applications where live connections are made rather than live and neutral

'Run' connected to +10V to 'Enable' Current Control and 'Override' Stall detection.

4-2 Installing the 506/507/508

WARNING!

Ensure that all wiring is electrically isolated and cannot be made "live" unintentionally by other personnel.

Wire Sizes

* Contains semiconductor fuses as recommended below.

Model	Maximum Output Rating	Function	Cable (Wire) Size	AC Supply Fuse Rating	SSD Drives Fuse Isolator Kit Part Numbers *
506	3A	DC Armature, AC Supply, Ground	1.5mm ² / 16AWG	10A	LA054664
507	6A	AC Supply, Ground DC Armature	2.5mm ² / 14AWG 1.5mm ² / 16AWG	10A	LA054664
508	12A	AC Supply DC Armature, Ground	6.0mm ² / 10AWG 4.0mm ² / 12AWG	20A	LA050062

Terminal Tightening Torques

Terminal	Torque Setting
Power	0.8 Nm 7 lbf-in
Control	0.56 Nm 5 lbf-in

Ferraz Semiconductor Fuses

Fuse Rating	Ferraz Type No.	SSD Drives Part No.
10A, 250V	250VFA10A6X32	CH230014
20A, 250V	250VFA20A6X32	CH230024

Requirements for UL Compliance

For installations requiring compliance with UL Standards.

Motor Overload Protection

An external motor overload protective device must be provided by the installer. This device can comprise of a thermal sensor within the motor winding monitored by an external relay but this combination cannot be evaluated by UL. Hence, it is the responsibility of the installer/local inspector to determine whether the combination is in compliance with the National Electrical Code or local code requirements.

Short Circuit Protection Requirements

UL Recognized semiconductor fuses must be installed upstream of the controllers. Refer to the semiconductor fuses table on the previous page for recommended semiconductor fuse manufacturer and type number.

Short Circuit Rating

The 506 and 507 controllers are suitable for use on a circuit capable of delivering not more than 1000 RMS symmetrical amperes, 240V maximum; whilst the 508 controller is suitable for use on a circuit capable of delivering not more than 5000 rms symmetrical amperes, 240V maximum.

Operating Ambient Temperature

The maximum operating ambient temperature rating is 40°C.

Field Wiring Temperature Rating

Use 75°C copper conductors only.

Field Wiring Terminal Markings

For correct field wiring connections that are to be made to each terminal, refer to Chapter 5: “Terminal Description” - Power Terminals and Chapter 3 “Technical Specification” - Control Terminals.

Power Wiring Terminals

The power wiring terminals accept a maximum conductor size of No. 10 AWG (5.3mm²).

Block Diagram

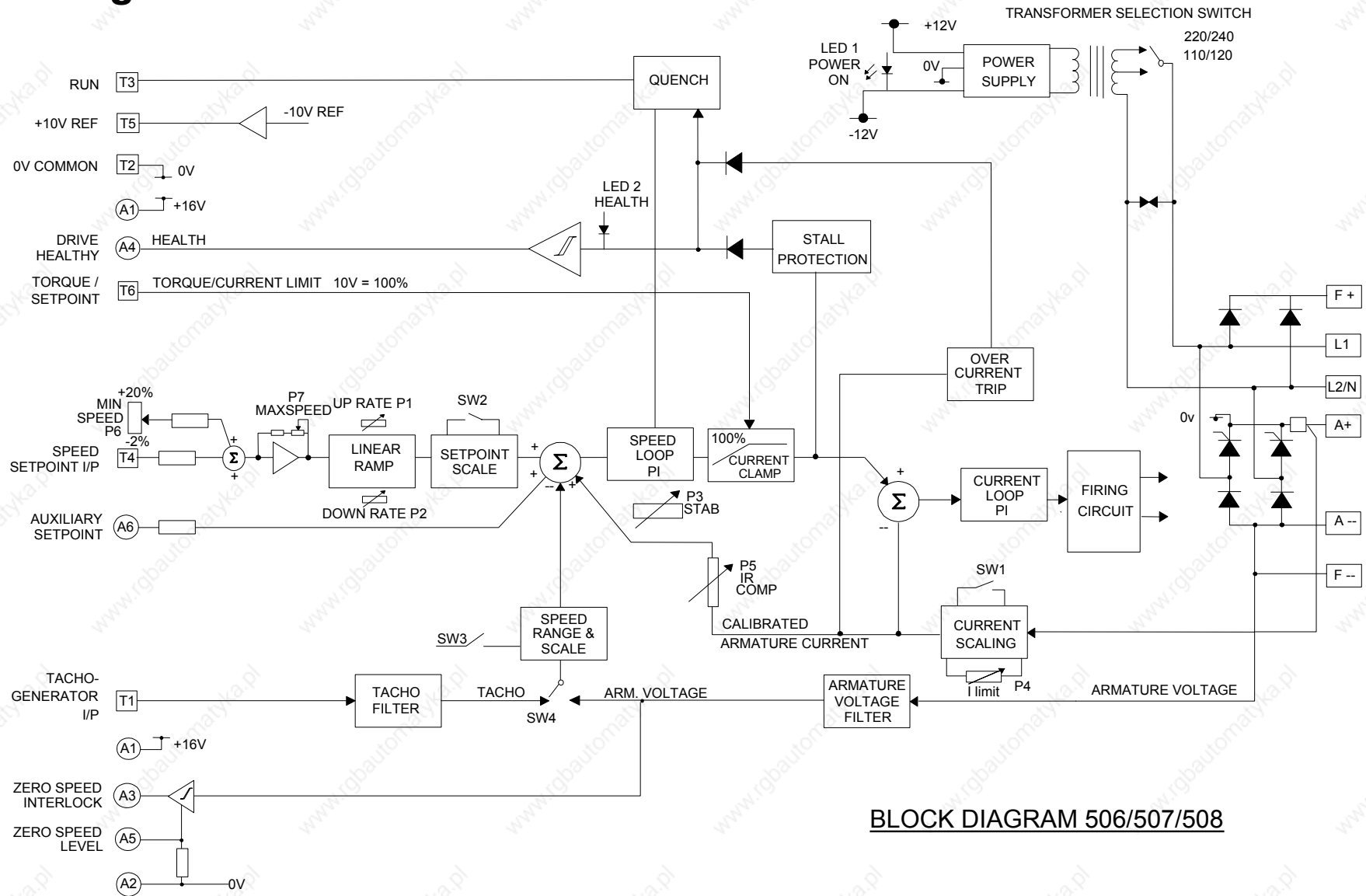

BLOCK DIAGRAM 506/507/508

4-6 Installing the 506/507/508

Terminal Tightening Torque

Refer to the Terminal Tightening torque table shown on page 4-2 for both the Power and Control Terminals.

Field Grounding Terminals

The field grounding terminals are identified with the International Grounding Symbol \oplus (IEC Publication 417, Symbol 5019).

Fitting

Figure 4.3 Product Mechanical Arrangement

Allow 50mm above and below product for cooling. Allow 8cm access to one side of the unit. Mount the unit with the cover in place.

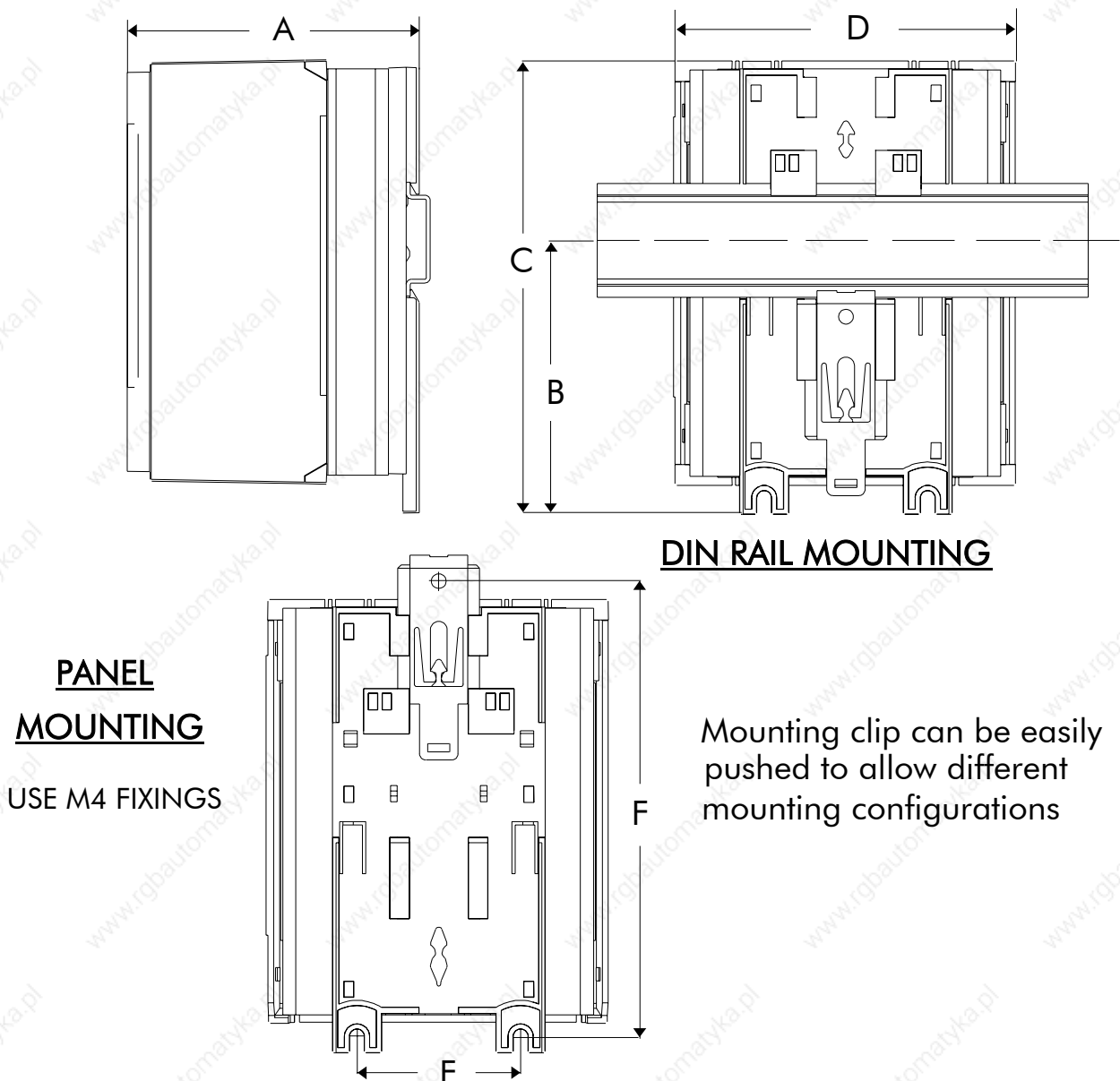

Installing the 506/507/508 4-7

DIM	IP20		
	506	507	508
A	80 mm	80 mm	90 mm
B	84 mm	84 mm	84 mm
C	140 mm	140 mm	140 mm
D	105 mm	105 mm	105 mm
E	50 mm	50 mm	50 mm
F	140 mm	140 mm	140 mm

Removing the Cover

WARNING!

Isolate the controller before fitting or removing the cover.

Remove the cover to access the terminals and switches.

It is removed easily when the unit is mounted on the backplate.

There are no screw fixings. It snaps back on to the front of the drive.

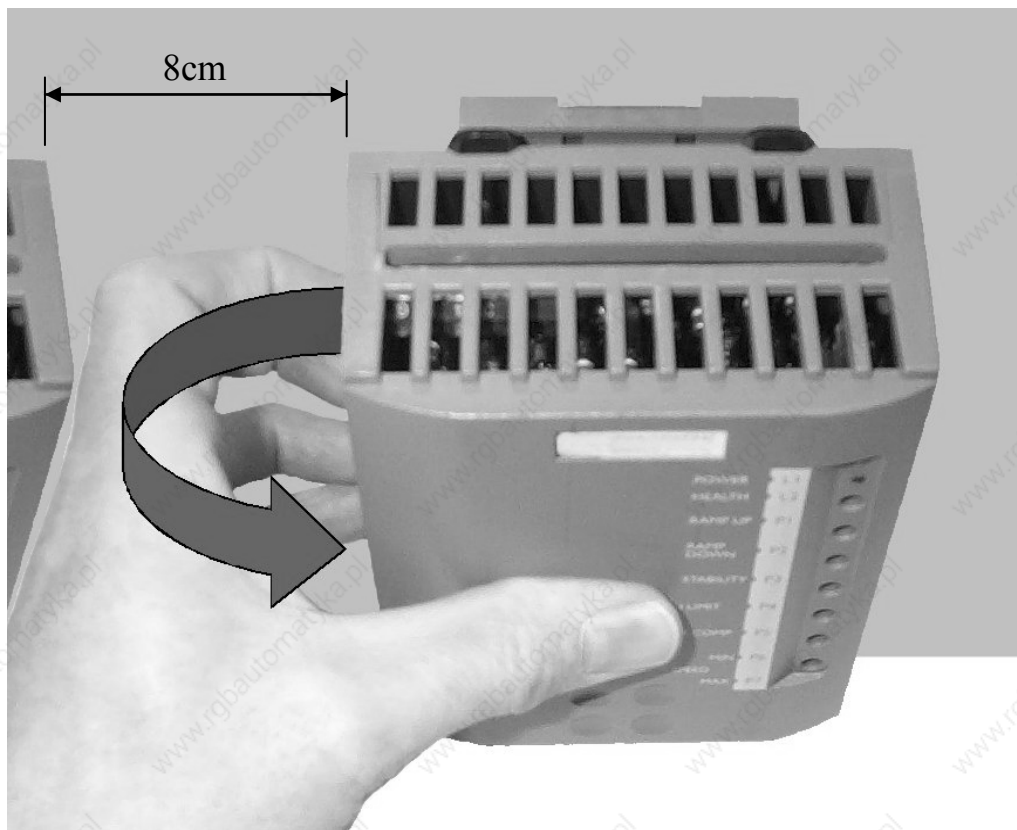

4-8 Installing the 506/507/508

Filter

Figure 4.4 Filter Mechanical Arrangement

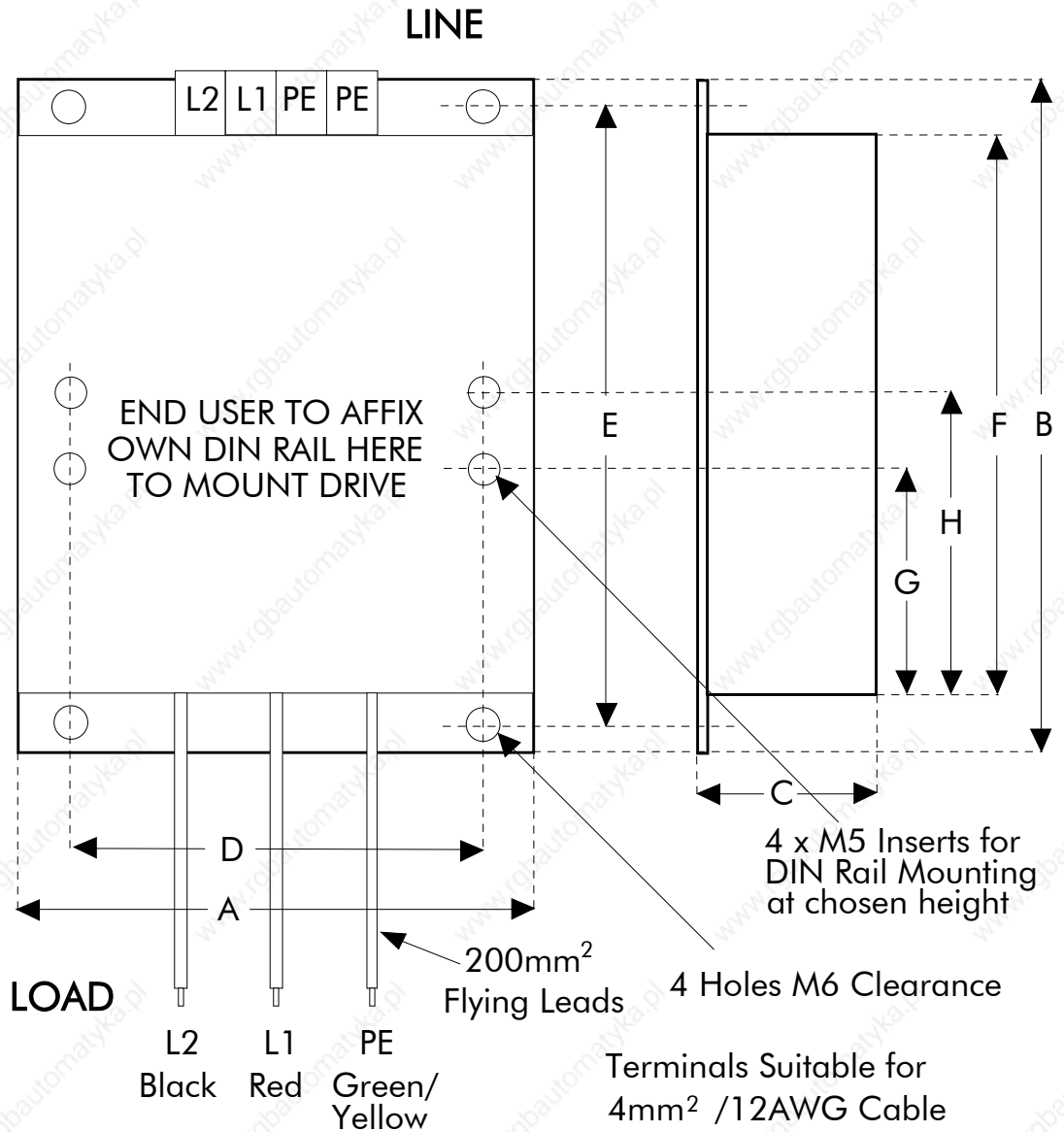

506/507/508									
Filter	Watt Loss*	Overall Dimensions			Fixing Centres				
		A	B	C	D	E	F	G	H
CO389115	9.5W	100	159	55	84	147	135	63	78

Note: * Note:- Watt Loss value is at a current output of 12 Amps dc.

EMC Connections

Figure 4.5 Wiring Diagram Mains Filter

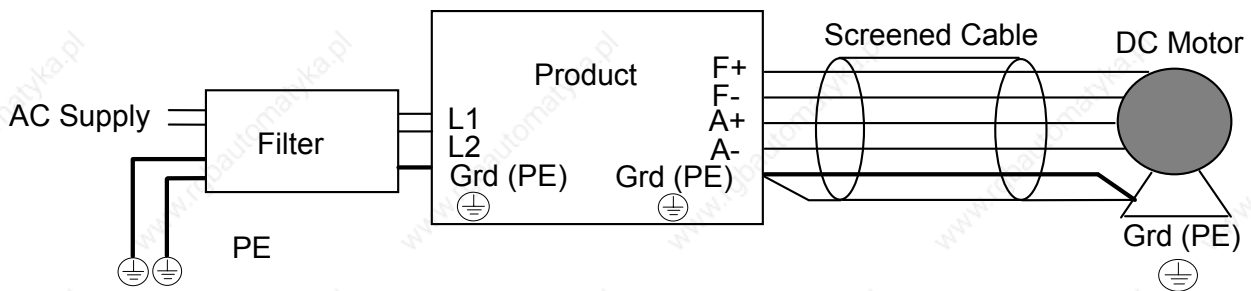

Installation and Set-Up

Warning

Before applying power check:-

Switch Selection

- Mains switch set to intended supply voltage, **Left** 110/120, **Right** 220/240
- Personality switches.

SW1	OFF	ON
506	0.25 to 3A	0.5 to 3A
507	0.5 to 3A	1 to 6A
508	1 to 6A	2 to 12A

Speed	Range	Maximum Feedback Voltage Range
SW2	SW3	Armature or Tacho
OFF	OFF	15 to 30
ON	OFF	30 to 60
OFF	ON	60 to 120
ON	ON	120 to 180

SW4	OFF	ON
FEEDBACK	TACH	ARMATURE

4-10 Installing the 506/507/508

Note: Even when intending to utilise tachogenerator feedback it may be wise to initially run under armature control. Set feedback voltage switches accordingly. Note that if this procedure is followed the tachogenerator must be temporarily disconnected as it will affect operation of the controller.

Potentiometer

(a) Product	Default
P1 Ramp Up	Anti-clockwise
P2 Ramp Down	Anti-clockwise
P3 Stability	Mid
P4 I Limit	Anti-clockwise
P5 IR Comp	Anti-clockwise
P6 Min Speed	Anti-clockwise
P7 Max Speed	Mid.

(b) External
Speed setpoint to minimum.

Motor

- (a) Check motor is compatible with controller and settings.
- (b) Check motor and load are free to rotate.

Wiring

- (a) Check there is no loose wire ends on the PCB.
- (b) Check that there are no free wire ends on external controls liable to contact grounded metal or earth (ground) referenced parts.

Applying Power

1. Power on LED 1 should illuminate.
2. Close “RUN” contact and apply a small speed setpoint (5%). Armature current should now flow, the motor should turn and run at a fixed speed.

If the motor runs above 5% up to top speed Open Run Contact.

If the controller is in “Armature” Control then excess speed is due to incorrect setting of SW2 and 3, the speed scaling.

If the controller is in “Tacho” control then excess speed is due to incorrect polarity of feedback. Alter wiring as follows:-

Problem

Action

Direction correct but overspeeding.

Reverse Tachogenerator polarity only.

Direction incorrect and overspeeding.

Reverse field polarity only.

If motor does not run, increase I limit potentiometer P4 as current may be insufficient for rotation. The Health light LED2 may light in this condition after 15 seconds indicating a Stall, remove and reapply power to reset condition.

If the motor is in control but runs in the wrong direction either:-

- (a) Armature Control - Reverse Field Polarity.
- (b) Tacho Control - Reverse Field AND Tacho Polarity.

3. Increase speed setpoint to maximum and check armature voltage does not exceed rated value, adjust maximum speed using P7. If a minimum speed setting is required reduce speed setpoint potentiometer to zero adjust minimum speed potentiometer P6 to give required value. With speed setpoint at maximum, re-adjust maximum speed with P7.
4. Adjust I Limit potentiometer to suit Motor Current Rating.

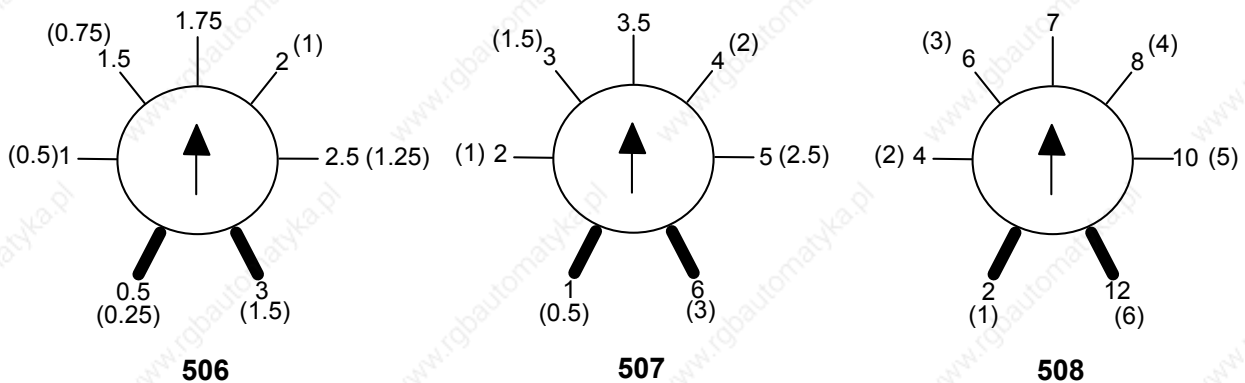

More accurate adjustment may be achieved by inserting a meter in the armature circuit.

5. Adjust Ramp Up P1 and Ramp Down P2 potentiometers as required.
6. In Armature Voltage Feedback, speed droop will occur as load is applied. Adjust IR compensation P5 to reduce this effect. Excessive adjustment may cause instability.
7. It may be necessary to adjust the Speed Stability Potentiometer P3 to improve speed response. Excessive adjustment may cause instability.

4-12 Installing the 506/507/508

Fault Finding

Problem	Possible Cause	Remedy
Controller will not power up - no 'on' indication.	Wrong supply voltage. Line fuses blown (if fitted).	Check setting on mains switch. It is likely that if too high a voltage has been used the Controller will be permanently damaged. Power off, check circuits and replace fuses.
Motor will not turn.	No run circuit. No setpoint.	Check run contact and wiring. Check connections to and operation of setpoint potentiometer.
Motor accelerates out of control with tacho-generator feedback and small setpoint.	Tacho polarity. Tacho linkage. Tacho faulty.	Power off and reverse tacho connections. Check tacho coupling to motor. Remove and replace tacho.
Motor rotates in the wrong direction. Speed is controlled though.	Motor connections are wrong for required direction with: 1. Armature voltage feedback. 2. Tacho-generator	Power off and reverse armature connections. Power off and reverse <u>both</u> armature and tacho connections.
Motor will not turn and the stall light comes on after 15 seconds in speed control mode.	Motor shaft locked or jammed. No field current (not applicable for permanent magnet motors). No armature current. Low current limit.	Power off and check motor and load for stiffness or jamming. Check that DC voltage across motor field terminals is present. If not power off and check field circuit for continuity. Power off and check armature circuit for continuity. Check current limit with +10V link on Controller.
Motor will only run at full speed.	Maximum speed setpoint.	Check connections to and operation of setpoint potentiometer.

Installing the 506/507/508 4-13

Problem	Possible Cause	Remedy
Motor will not run at correct maximum speed.	Wrong speed range selection on preset switches.	Refer to Installation and Set-up chapter.
Stall light comes on after 15 seconds in current control mode.	Incorrect wiring of run contact.	Run contact should be wired between the two terminals marked 'run' and '+10V'.
Stall light comes on immediately after the 'run' contact is closed.	Faulty or incorrect load across the 'A+' and 'A-' terminals.	Check motor armature thoroughly. The Controller should not be used on motors with a low inductance.

4-14 Installing the 506/507/508

ROUTINE MAINTENANCE AND REPAIR

Routine Maintenance

Periodically inspect the motor speed controller for build-up of dust or obstructions that may affect ventilation of the unit. Remove this using dry air.

Repair

There are no user-serviceable components.

IMPORTANT: MAKE NO ATTEMPT TO REPAIR THE UNIT - RETURN IT TO PARKER SSD DRIVES.

Returning the Unit to Parker SSD Drives

Please have the following information available:

- The model and serial number - see the unit's rating label
- Details of the fault

Contact your nearest Parker SSD Drives Service Centre to arrange return of the item.

You will be given a *Returned Material Authorisation*. Use this as a reference on all paperwork you return with the faulty item. Pack and despatch the item in the original packing materials; or at least an antistatic enclosure. Do not allow packaging chips to enter the unit.

5-2 Routine Maintenance and Repair

EMC CERTIFICATION FOR THE 506/507/508

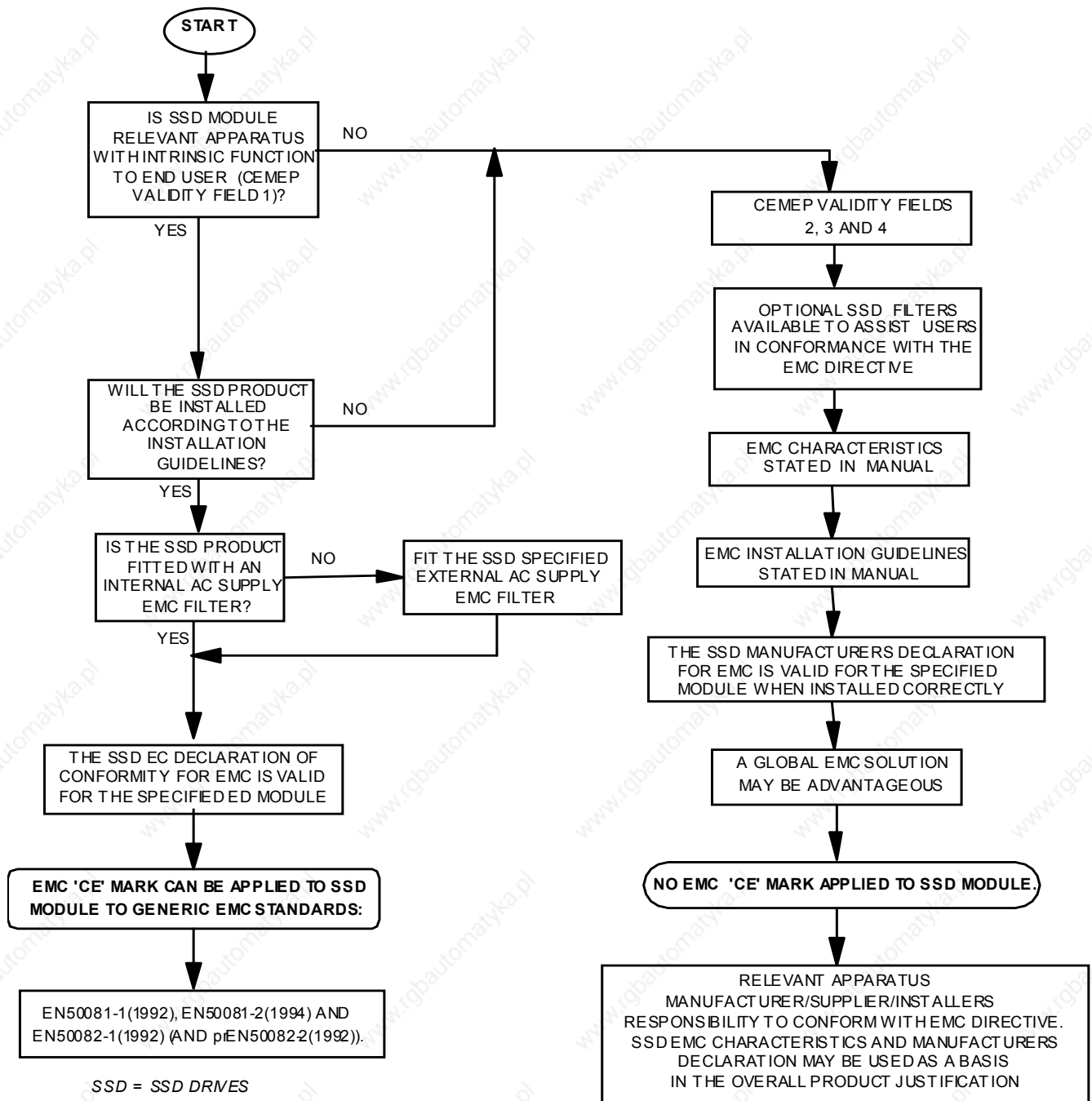



Figure 6-1 Parker SSD Drives EMC 'CE' Mark Validity Chart

For more information refer to HA388879 EMC Installation Guidelines for Modules and Systems available from your local Parker SSD Drives office.

6-2 Certification for the 506/507/508

Certificates

506/507/508	
CE EC DECLARATIONS OF CONFORMITY Date CE marked first applied: 01.04.2000	
EMC Directive	Low Voltage Directive
In accordance with the EEC Directive 2004/108/EC We Parker SSD Drives, address as below, declare under our sole responsibility that the above Electronic Products when installed and operated with reference to the instructions in the Product Manual (provided with each piece of equipment) is in accordance with the relevant clauses from the following standard:- * BSEN61800-3 (2004)	In accordance with the EEC Directive 2006/95/EC We Parker SSD Drives, address as below, declare under our sole responsibility that the above Electronic Products when installed and operated with reference to the instructions in the Product Manual (provided with each piece of equipment), is in accordance with the relevant clauses from the following standard :- EN50178 (1998)
MANUFACTURERS DECLARATIONS	
EMC Declaration	Machinery Directive
We Parker SSD Drives, address as below, declare under our sole responsibility that the above Electronic Products when installed and operated with reference to the instructions in the Product Manual (provided with each piece of equipment) is in accordance with the relevant clauses from the following standard:- * BSEN61800-3 (2004)	The above Electronic Products are components to be incorporated into machinery and may not be operated alone. The complete machinery or installation using this equipment may only be put into service when the safety considerations of the Directive 89/392/EEC are fully adhered to. Particular reference should be made to EN60204-1 (Safety of Machinery - Electrical Equipment of Machines). All instructions, warnings and safety information of the Product Manual must be adhered to.
 <hr/> Dr Martin Payn (Conformance Officer)	
* Compliant with the immunity requirements of the Standard without specified EMC filters. * 690PB only when fitted with an internal or external filter.	
PARKER SSD DRIVES NEW COURTWICK LANE, LITTLEHAMPTON, WEST SUSSEX BN17 7RZ TELEPHONE: +44(0)1903 737000 FAX: +44(0)1903 737100 Registered Number: 4806503 England. Registered Office: 55 Maylands Avenue, Hemel Hempstead, Herts HP2 4SJ	

Issued for compliance with the EMC Directive when the unit is used as *relevant apparatus*.

This is provided to aid your justification for EMC compliance when the unit is used as a *component*.

The drive is CE marked in accordance with the low voltage directive for electrical equipment and appliances in the voltage range when installed correctly.

Since the potential hazards are mainly electrical rather than mechanical, the drive does not fall under the machinery directive. However, we do supply a manufacturer's declaration for when the drive is used (as a *component*) in machinery.

TECHNICAL SPECIFICATIONS

Input Supply

Parameter	Symbol	Value	Units
Frequency		50/60 \pm 10%	Hz
Voltage	Vs	110/120 \pm 10% or 220/240 \pm 10% (Earth (TN) or non-earth (IT) referenced)	V

Speed Control

- (1) Range selected by built in switches.
- (2) With IR comp setting optimised.
- (3) Consideration must be given to the motor at it may overheat at low speed.

Parameter	Symbol	Value	Units
Stall detect time		15 maximum 20 typical	s
Type of controller		Variable proportional plus integral	
Feedback method ⁽¹⁾	Va	Tacho	
0-100% load regulation		2 ⁽²⁾ (typically) 0.1 (typically)	
Max. torque speed range		20:1 100:1 ⁽³⁾	%

Current (Torque) Control

- (1) Range selected by built in switches.
- (2) Suitable for armature time constants not less than 5ms.
- (3) **All control terminals are at a potential of the peak of the input supply with respect to earth (ground) \oplus .**

All cables should be rated for this voltage.

Parameter	Symbol	Value	Units
Overspeed limiting ⁽¹⁾		Standard ⁽¹⁾	
Type of controller ⁽²⁾		Fixed proportional plus integral	
Feedback method		Non-isolated shunt ⁽³⁾	
Linearity		2	%

7-2 Technical Specification

Adjustment Range			
Parameter	Symbol	Value	Units
Armature loss comp.	IR comp	0 - 25% of Va	
Maximum speed	N max	100% ± 25%	
Minimum speed	N min	0 - 25% of N max	%
Ramp up time	Ramp	1 - 15 (minimum)	s
Ramp down time	Ramp	1 - 15 (minimum)	s

Environmental Requirements	
Operating Temperature	0 to +40°C (Derate 1.5% / Degree above 40°C)
Max. Operating Temperature	50°C
Humidity	85% R.H. at 40°C (non condensing)
Altitude	Above 1000m derate at 1% / 100m
Atmosphere	Non-flammable, non-corrosive and dust free
Storage Temperature Range	-25°C to +55°C
Transport Temperature Range	-25°C to +55°C
Enclosure	IP2X suitable for cubicle mounting
Installation Category	Overvoltage Category III.
Pollution	Pollution Degree 2.

EMC Technical Ratings

Immunity

Port	Phenomenon	Test Standard	Level	Criterion	Generic Standard
Enclosure Port	ESD RF Field	BS EN61000-4-2(1995)	8kV AD 10V/m,1kHz AM	Self Recovery No Change	EN50082 -1 (1992), and EN50082 -2 (1995)
Power Ports	Fast Transient Burst	BS EN61000-4-4(1995)	2kV	Self Recovery	
Signal & Control	Fast Transient Burst	BS EN61000-4-4(1995)	2kV	Self Recovery	
Power Interfaces	Fast Transient Burst	BS EN61000-4-4(1995)	2kV	Self Recovery	

Emissions

These levels of performance are achieved when installed as specified with the recommended Supply Filter.

* Achieved with up to 50m of motor cable.

Port	Phenomenon	Test Standard	Level	Generic Standard
Enclosure Port	Radiated	EN55011	Class B	EN50081-1 (1992)
Power Port	Conducted	EN55011	Class B*	EN50081-2 (1994)

Electrical Ratings

Output Ratings with typical armature voltage, V_a , 80/90V (160/180V)

- (1) Range selected by built in switches.
- (2) When the controller is energised the dc motor shunt field is permanently energised. It is the responsibility of the installer to ensure that this is not detrimental to the long term reliability of the dc motor.

Parameter	506		507		508	
Maximum Armature Output Current (IA) ⁽¹⁾	1.5A	3A	3A	6A	6A	12A
Typical Motor Horsepower (Hp)						
90V Armature (110/120V AC)	1/10	1/6	1/6	1/3	1/3	3/4
180V Armature (220/240V AC)	1/6	1/3	1/3	3/4	3/4	2
Typical Motor Power (kW)						
90V Armature (110/120V AC)	0.07	0.125	0.125	0.25	0.25	0.55
180V Armature (220/240V AC)	0.125	0.25	0.25	0.55	0.55	1.5
Controller loss (W)	5	10	10	20	20	40
Maximum AC Supply Current (Is, A rms)	3	4.5	6	9	12	18
Maximum I ² t for fusing (A ² s)	36	36	80	80	365	365
Maximum form factor (Is/IA)	2	1.5	2	1.5	2	1.5
Maximum Field Current ⁽²⁾ (If, A dc)	2					
Field Voltage (0.9 x Vs) V dc	V					
110/120V AC	90-100					
220/240V AC	180-200					

Adjustment Ranges

- * Range selected by built in switches.

Parameter	506	507	508
Maximum current * (I max, A)	0.25 - 3	0.5 - 6	1 - 12

Product Code			
Block	Product	Code	Feature
1	Basic Product	506	3 Amp
		507	6 Amp
		508	12 Amp
2	Livery	00	Standard
		01 to 99	Customer
3	Cover	20	IP20 Cover
4	Special Options	00	Standard
		01 to 99	Documented Special Options

ISS.	MODIFICATION	ECN No.	DATE	DRAWN	CHK'D
6	Manual transferred into new design template. Removed references to IP00. Added warnings to wiring diagrams. Added Watt Loss column.	12028 11945	24.02.98	FEP	GDR
7	Replaced prEN50178(1995) with EN50178(1998) and updated EC Declaration of Conformity. Removed address list from inside manual to back cover.	13114 13164	01.03.99	FEP	GDR
8	Company name change Certificate updated on page 6-2	18354	19/07/05	CM	GDR
9	Cover removal improved, page 4-8	19650	17/10/06	CM	GDR
10	Ambient temperature amended New company name	20002 (19591)	20/06/07	CM	GDR
FIRST USED ON		MODIFICATION RECORD			
		506/507/508 Product Manual			
		DRAWING NUMBER			SHT. 2
		ZZ389427			OF 2