

# SIEMENS

## SIMATIC S5

### S5-135U/155U

#### System Manual

Order No. 6ES5 998-0SH21  
Release 03

Notes on Using this Manual	1
Centralized and Distributed Configuration of a Programmable Controller	2
Installation Guidelines	3
Central Controllers and Expansion Units, Power Supply Units	4
CPUs, Memory Cards, Memory Submodules, Interface Submodules	5
Multiprocessor Operation/Coordinators	6
Interface Modules	7
Digital Input/Output Modules	8
Analog Input/Output Modules	9
Connector Assignments	10
Appendix: Ordering Information, Further Reading	11
Index	12

## **Copyright**

Copyright © Siemens AG 1993 All Rights Reserved

The reproduction, transmission or use of this document or its contents is not permitted without express written authority.

Offenders will be liable for damages. All rights, including rights created by patent grant or registration of a utility model or design, are reserved.

## **Disclaimer of Liability**

We have checked the contents of this manual for agreement with the hardware and software described. Since deviations cannot be precluded entirely, we cannot guarantee full agreement. However, the data in this manual are reviewed regularly and any necessary corrections included in subsequent editions. Suggestions for improvement are welcomed.

Technical data subject to change.

## **Safety-related guidelines**

This manual contains notices which you should observe to ensure your own personal safety, as well as to protect the product and connected equipment. These notices are highlighted in the manual by a warning triangle and are marked as follows according to the level of danger:



### **Warning**

indicates that death, severe personal injury or substantial property damage can result if proper precautions are not taken.



### **Caution**

indicates that minor personal injury or property damage can result if proper precautions are not taken.

Only **qualified personnel** should be allowed to install and work on this equipment. Qualified persons are defined as persons who are authorized to commission, to ground and to tag equipment, systems and circuits in accordance with established safety practices and standards.

# SIEMENS

## Warning

### **Risks involved in the use of so-called SIMATIC-compatible modules of non-Siemens manufacture**

"The manufacturer of a product (SIMATIC in this case) is under the general obligation to give warning of possible risks attached to his product. This obligation has been extended in recent court rulings to include parts supplied by other vendors. Accordingly, the manufacturer is obliged to observe and recognize such hazards as may arise when a product is combined with products of other manufacture.

**For this reason, we feel obliged to warn our customers who use SIMATIC products not to install so-called SIMATIC-compatible modules of other manufacture in the form of replacement or add-on modules in SIMATIC systems.**

Our products undergo a strict quality assurance procedure. We have no knowledge as to whether outside manufacturers of so-called SIMATIC-compatible modules have any quality assurance at all or one that is nearly equivalent to ours. These so-called SIMATIC-compatible modules are **not** marketed in agreement with Siemens; we have never recommended the use of so-called SIMATIC-compatible modules of other manufacture. The advertising of these other manufacturers of so-called SIMATIC-compatible modules wrongly creates the impression that the subject advertised in periodicals, catalogs or at exhibitions had been agreed with us. Where so-called SIMATIC-compatible modules of non-Siemens manufacture are combined with our SIMATIC automation systems, we have a case of our product being used contrary to recommendations. Because of the variety of applications of our SIMATIC automation systems and the large number of these products marketed worldwide, we cannot give a concrete description specifically analyzing the hazards created by these so-called SIMATIC-compatible modules. It is beyond the manufacturer's capabilities to have all these so-called SIMATIC-compatible modules checked for their effect on our SIMATIC products. If the use of so-called SIMATIC-compatible modules leads to defects in a SIMATIC automation system, no warranty for such systems will be given by Siemens.

In the event of product liability damages due to the use of so-called SIMATIC-compatible modules, Siemens are not liable since we took timely action in warning users of the potential hazards involved in so-called SIMATIC-compatible modules."

## Guidelines for Handling Electrostatically Sensitive Devices (ESD)

### 1 What is ESD?

VLSI chips (MOS technology) are used in practically all SIMATIC and TELEPERM modules. These VLSI components are, by their nature, very sensitive to overvoltage and thus to electrostatic discharge:

They are therefore defined as

**E**lectrostatically **S**ensitive **D**evelopments: "ESD"

"ESD" is the abbreviation used internationally.

The following warning label on the cabinets, subracks and packing indicates that electrostatically sensitive components have been used and that the modules concerned are susceptible to touch:

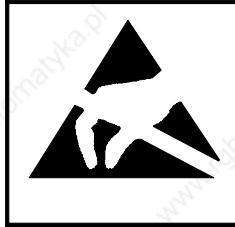

**ESDs** can be destroyed by voltage and energy levels which are far below the level perceptible to human beings. Such voltages already occur when a component or a module is touched by a person who has not been electrostatically discharged. Components which have been subjected to such overvoltages cannot, in most cases, be immediately detected as faulty; the fault occurs only after a long period in operation.

An electrostatic discharge

- of 3500 V can be felt
- of 4500 V can be heard
- must take place at a minimum of 5000 V to be seen.

**But** just a fraction of this voltage can already damage or destroy an electric component.

The typical data of a component can suffer due to damage, overstressing or weakening caused by electrostatic discharge; this can result in temporary fault behavior, e.g. in the case of

- temperature variations,
- mechanical shocks,
- vibrations,
- change of load.

Only the consequent use of protective equipment and careful observation of the precautions for handling such components can effectively prevent functional disturbances and failures of ESD modules.

## 2 When is a Static Charge Formed?

One can never be sure that the human body or the material and tools which one is using are not electrostatically charged.

Small charges up to 100 V are very common; these can, however, very quickly rise up to 35 000 V!

Examples of static charge:

– Walking on a carpet	up to	35 000 V
– Walking on a PVC flooring	up to	12 000 V
– Sitting on a cushioned chair	up to	18 000 V
– Plastic desoldering unit	up to	8 000 V
– Books, etc. with a plastic binding	up to	8 000 V
– Plastic bag	up to	5 000 V
– Plastic coffee cup	up to	5 000 V

## 3 Important Protective Measures against Static Discharge

- Most plastic materials are highly susceptible to static charge and must therefore be kept as far away as possible from ESDs!
- Personnel who handle ESDs, the work table and the packing must all be carefully grounded!

## 4 Handling of ESD Modules

- One basic rule to be observed is that electronic modules should be touched by hand only if this is necessary for any work to be done on them. Do not touch the component pins or the conductors.
- Touch components only if
  - the person is grounded at all times by means of a wrist strap or
  - the person is wearing special anti-static shoes or shoes with a grounding strip.
- Before touching an electronic module, the person concerned must ensure that (s)he is not carrying any static charge. The simplest way is to touch a conductive, grounded item of equipment (e.g. a blank metallic cabinet part, water pipe, etc.) before touching the module.
- Modules should not be brought into contact with insulating materials or materials which take up a static charge, e.g. plastic foil, insulating table tops, synthetic clothing, etc..
- Modules should only be placed on conductive surfaces (table with anti-static table top, conductive foam material, anti-static plastic bag, anti-static transport container).
- Modules should not be placed in the vicinity of visual display units, monitors or TV sets (minimum distance from screen > 10 cm).

The diagram on the next page shows the required protective measures against electrostatic discharge.

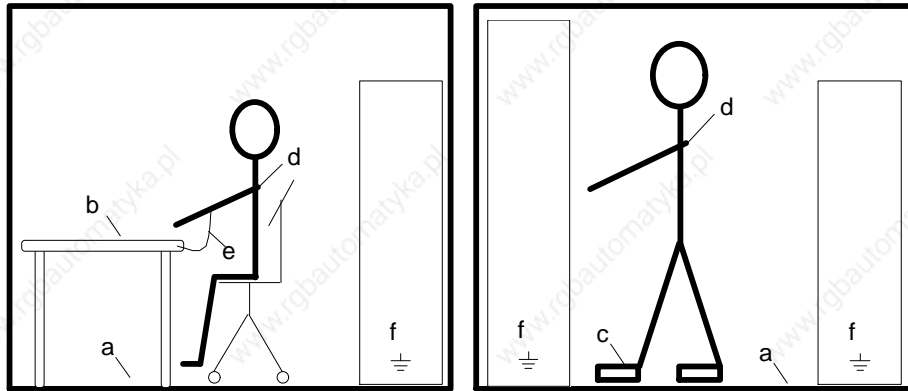

Sitting position

Standing position

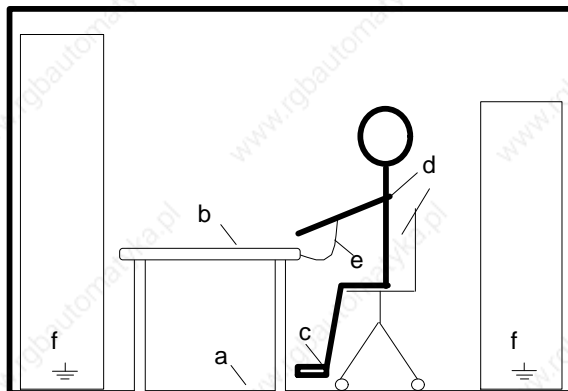

Standing/sitting position

- a Conductive flooring
- b Anti-static table
- c Anti-static shoes
- d Anti-static coat
- e Grounding wrist strap
- f Grounding connection of the cabinets

## 5 Measurements and Modifications to ESD Modules

- Measurements on modules may only be carried out under the following conditions:
  - the measuring equipment is grounded (e.g. via the PE conductor of the power supply system) or
  - when electrically isolated measuring equipment is used, the probe must be discharged (e.g. by touching the metallic casing of the equipment) before beginning measurements.
- Only grounded soldering irons may be used.

## 6 Shipping of ESD Modules

Anti-static packing material must always be used for modules and components, e.g. metalized plastic boxes, metal boxes, etc. for storing and dispatch of modules and components.

If the container itself is not conductive, the modules must be wrapped in a conductive material such as conductive foam, anti-static plastic bag, aluminum foil or paper. Normal plastic bags or foils should not be used under any circumstances.

For modules with built-in batteries ensure that the conductive packing does not touch or short-circuit the battery connections; if necessary cover the connections with insulating tape or material.

# Contents

<b>1</b>	<b>Notes on Using this Manual</b> .....	<b>1 - 1</b>
<b>2</b>	<b>Centralized and Distributed Configuration of a Programmable Controller</b> .....	<b>2 - 3</b>
2.1	Application .....	2 - 4
2.2	Centralized and Distributed Configuration .....	2 - 5
2.2.1	Installing a PLC with Centralized Configuration .....	2 - 6
2.2.2	Installing a PLC with Distributed Configuration .....	2 - 7
2.3	Examples .....	2 - 9
<b>3</b>	<b>Installation Guidelines</b> .....	<b>3 - 3</b>
3.1	Principles of Installation of Systems for EMC .....	3 - 4
3.1.1	Overview of Possible Interference .....	3 - 4
3.1.2	The Most Important Basic Rules for Ensuring EMC .....	3 - 7
3.2	Installation of Programmable Controllers for EMC .....	3 - 9
3.2.1	Basic Rules for Assembling and Grounding the Inactive Metal Parts .....	3 - 9
3.2.2	Example of Cabinet Assembly for EMC .....	3 - 10
3.2.3	Example of Rack and Wall Mounting for EMC .....	3 - 12
3.3	Wiring of Programmable Controllers for EMC .....	3 - 14
3.3.1	Routing of Cables .....	3 - 14
3.3.2	Equipotential Bonding .....	3 - 16
3.3.3	Shielding of Cables and Lines .....	3 - 17
3.3.4	Special Measures for Interference-Free Operation .....	3 - 19
	AC power connection for programmers .....	3 - 20
	Cabinet lighting .....	3 - 20
3.3.5	Checklist for the Electromagnetically Compatible Installation of Control Systems .....	3 - 21

3.4	Power Supplies for Programmable Controllers and I/Os . . . . .	3 - 22
3.4.1	Power Supplies for Control Systems with SIMATIC S5 . . . . .	3 - 22
3.4.2	Connecting the Programmable Controller and Load Power Supply . . . . .	3 - 23
3.4.3	Connecting Non-Floating or Floating Modules . . . . .	3 - 28
3.5	Interference-Free Installation of Centralized and Distributed Interface Circuits . . . . .	3 - 30
3.5.1	Interference-Free Installation of Centralized Interface Circuits . . . . .	3 - 30
3.5.2	Interference-Free Installation of Distributed Interface Circuits . . . . .	3 - 30
3.6	Interference-Free Connection of Monitors . . . . .	3 - 32
3.6.1	Interference-Free Connection of a Monitor to the CP of the S5 Controller . . . . .	3 - 32
3.6.2	Shielding and Grounding . . . . .	3 - 33
3.7	Selection and Installation of Cabinets with SIMATIC S5 . . . . .	3 - 35
3.7.1	Types of Cabinet . . . . .	3 - 36
3.7.2	Clearances in Cabinets . . . . .	3 - 36
3.7.3	Removal of Power Dissipation from Cabinets . . . . .	3 - 39
3.7.4	Examples for Determining the Type of Cabinet . . . . .	3 - 40
3.7.5	Determining the Power Dissipation of Modules . . . . .	3 - 41
<b>4</b>	<b>Central Controllers and Expansion Units, Power Supply Units . . . . .</b>	<b>4 - 3</b>
4.1	S5-135U/155U Central Controller . . . . .	4 - 4
4.1.1	Technical Description . . . . .	4 - 4
4.1.2	Installation . . . . .	4 - 8
4.1.3	Startup . . . . .	4 - 12
4.1.4	Repair Guidelines . . . . .	4 - 14
4.1.5	Technical Specifications . . . . .	4 - 15
4.2	Expansion Units . . . . .	4 - 17
4.2.1	Technical Description of the Expansion Units . . . . .	4 - 18
4.2.2	Installing the Expansion Units . . . . .	4 - 20
4.2.3	Technical Specifications of the Expansion Units . . . . .	4 - 20
4.3	Power Supply Units . . . . .	4 - 21
4.3.1	Product Overview . . . . .	4 - 21
	Power supply types . . . . .	4 - 21
	Basic functions . . . . .	4 - 22
	Monitoring functions . . . . .	4 - 22
	Signalling functions . . . . .	4 - 23
	Inputs and outputs . . . . .	4 - 24
	Indicators and controls . . . . .	4 - 25
4.3.2	Setting and Connecting the Power Supply Unit . . . . .	4 - 26
	Brief instructions for startup . . . . .	4 - 27
	Establishing the setting and cabling . . . . .	4 - 28
	Removing the power supply unit . . . . .	4 - 31
	Setting the jumpers . . . . .	4 - 32
	Fitting the power supply unit . . . . .	4 - 33
	Wiring the power supply unit . . . . .	4 - 33
	Fitting the lithium battery . . . . .	4 - 34



	Removing the right-hand fan and connecting the rechargeable battery . . . . .	4 - 36
	Fitting the filter subdrawer . . . . .	4 - 37
	Setting the voltage selector switch . . . . .	4 - 37
	Switching on the power supply unit for the first time . . . . .	4 - 38
4.3.3	Fault Indications/Fault Diagnostics . . . . .	4 - 39
4.3.4	Maintenance and Repairs . . . . .	4 - 43
	Replacing the lithium battery . . . . .	4 - 44
	Replacing a fan . . . . .	4 - 45
	Replacing the rechargeable battery . . . . .	4 - 47
	Replacing the filter mat . . . . .	4 - 49
	Replacing a power supply unit . . . . .	4 - 50
4.3.5	Description of Internal Sequences in the Power Supply Unit . . . . .	4 - 52
	Behavior upon failure of the system supply . . . . .	4 - 52
	Behavior upon failure of fans . . . . .	4 - 53
4.3.6	Technical Specifications of the Power Supply Units . . . . .	4 - 54
4.4	24 V/4 A Load Power Supply . . . . .	4 - 61
4.4.1	Technical Description . . . . .	4 - 61
	Application . . . . .	4 - 61
	Design . . . . .	4 - 61
	Outputs . . . . .	4 - 62
	Inputs . . . . .	4 - 63
	Indicators . . . . .	4 - 63
	Controls . . . . .	4 - 63
	Front connector . . . . .	4 - 63
4.4.2	Startup . . . . .	4 - 65
	Setting the AC voltage . . . . .	4 - 65
	Connecting the AC leads . . . . .	4 - 65
4.4.3	Fault Indications/Fault Diagnostics . . . . .	4 - 66
4.4.4	Technical Specifications . . . . .	4 - 67
4.5	6ES5 955-3NA12 Power Supply Unit . . . . .	4 - 69
4.5.1	Technical Description . . . . .	4 - 69
	Indicators and controls . . . . .	4 - 70
	Terminals . . . . .	4 - 71
	15 V auxiliary submodule . . . . .	4 - 71
4.5.2	Setting the Power Supply Unit . . . . .	4 - 72
	Locations of jumpers . . . . .	4 - 72
	Functions of the jumpers . . . . .	4 - 72
	Setting the fan monitor . . . . .	4 - 73
	Setting the backup battery monitor . . . . .	4 - 74
4.5.3	Installation . . . . .	4 - 75
	Installing the 15 V auxiliary submodule . . . . .	4 - 75
4.5.4	Operation . . . . .	4 - 76
	General notes on the power supply unit . . . . .	4 - 76
	Fault indications/diagnostics . . . . .	4 - 77
4.5.5	Maintenance . . . . .	4 - 78
	Replacing the backup battery . . . . .	4 - 78
	Replacing the fans . . . . .	4 - 79
4.5.6	Technical Specifications . . . . .	4 - 80

<b>5</b>	<b>CPUs, Memory Cards, Memory Submodules, Interface Submodules .....</b>	<b>5 - 5</b>
5.1	CPU 948.....	5 - 6
5.1.1	Technical Description .....	5 - 6
	Application .....	5 - 6
	Design .....	5 - 7
5.1.2	Installation and Startup.....	5 - 8
	Jumper settings .....	5 - 8
	Removing and inserting the module .....	5 - 9
	Controls and indicators .....	5 - 10
	Startup .....	5 - 15
5.1.3	Interfaces of the CPU 948 .....	5 - 17
5.1.4	Technical Specifications .....	5 - 18
5.2	CPU 928B .....	5 - 21
5.2.1	Technical Description .....	5 - 21
	Application .....	5 - 21
	Design .....	5 - 21
	User memory.....	5 - 22
	PG Interface SI1 .....	5 - 22
	Second interface SI2.....	5 - 23
	Process interrupt processing .....	5 - 24
5.2.2	Installation and Startup.....	5 - 24
	Jumper settings .....	5 - 24
	Removing and inserting the module .....	5 - 24
	Controls and indicators.....	5 - 26
5.2.3	Technical Specifications .....	5 - 31
5.3	CPU 928.....	5 - 33
5.3.1	Technical Description .....	5 - 33
	Application .....	5 - 33
	Design .....	5 - 33
	User memory.....	5 - 34
	Process interrupt processing.....	5 - 34
5.3.2	Installation and Startup.....	5 - 35
	Removing and inserting the module .....	5 - 35
	Controls and indicators.....	5 - 36
	Startup .....	5 - 40
5.3.3	Technical Specifications .....	5 - 41
5.4	CPU 922.....	5 - 43
5.4.1	Technical Description .....	5 - 43
	Application .....	5 - 43
	Design .....	5 - 43
	Process interrupt processing.....	5 - 44
5.4.2	Installation and Startup.....	5 - 45
	Removing and inserting the module .....	5 - 45
	Controls and indicators.....	5 - 46
	Startup .....	5 - 50
5.4.3	Technical Specifications .....	5 - 51

5.5	374 Flash EPROM Cards . . . . .	5 - 53
5.5.1	Technical Description . . . . .	5 - 53
5.5.2	Notes on Operation . . . . .	5 - 53
5.5.3	Technical Specifications . . . . .	5 - 54
5.6	376 Memory Submodules . . . . .	5 - 55
5.6.1	Technical Description . . . . .	5 - 55
5.6.2	Notes on Operation . . . . .	5 - 55
5.6.3	Technical Specifications . . . . .	5 - 56
5.7	377 Memory Submodules . . . . .	5 - 57
5.7.1	Technical Description . . . . .	5 - 57
5.7.2	Notes on Operation . . . . .	5 - 57
5.7.3	RAM Submodules with Battery Backup . . . . .	5 - 58
	Operational states . . . . .	5 - 58
	Battery monitoring and battery fault . . . . .	5 - 59
	Inserting or replacing the backup battery . . . . .	5 - 60
	Using the RAM submodule with battery backup . . . . .	5 - 61
5.7.4	Technical Specifications . . . . .	5 - 63
5.8	Interface Submodules . . . . .	5 - 65
5.8.1	Installing and Removing the Interface Submodules . . . . .	5 - 66
	Installation . . . . .	5 - 66
	Removal . . . . .	5 - 67
5.8.2	PG Submodule . . . . .	5 - 68
	Application . . . . .	5 - 68
	Circuitry . . . . .	5 - 68
	Data transmission rate . . . . .	5 - 68
	Pin assignments of the PG submodule . . . . .	5 - 69
	Jumper settings on the PG submodule . . . . .	5 - 70
	Standard connecting cable for the PG submodule . . . . .	5 - 71
5.8.3	V.24 Submodule . . . . .	5 - 72
	Application . . . . .	5 - 72
	Circuitry . . . . .	5 - 72
	Data transmission rate . . . . .	5 - 72
	Pin assignments of the V.24 submodule . . . . .	5 - 73
	Jumper settings of the V.24 submodule . . . . .	5 - 74
	Standard connecting cables of the V.24 submodule . . . . .	5 - 75
5.8.4	TTY Submodule . . . . .	5 - 79
	Application . . . . .	5 - 79
	Circuitry . . . . .	5 - 79
	Data transmission rate . . . . .	5 - 80
	Pin assignments of the TTY submodule . . . . .	5 - 80
	Jumper settings on the TTY submodule . . . . .	5 - 81
	Standard connecting cables for the TTY submodule . . . . .	5 - 82
5.8.5	RS422 A/485 Submodule . . . . .	5 - 85
	Application . . . . .	5 - 85
	Circuitry . . . . .	5 - 85
	Data transmission rate . . . . .	5 - 86
	Pin assignments of the RS422 A/485 submodule . . . . .	5 - 86
	Jumper settings on the RS422 A/485 submodule . . . . .	5 - 87
	Standard connecting cables to the RS422 A/485 submodule . . . . .	5 - 90

5.8.6	SINEC L1 Submodule .....	5 - 91
	Application .....	5 - 91
	Circuitry.....	5 - 91
	Data transmission rate.....	5 - 91
	Pin assignments of the SINEC L1 submodule.....	5 - 92
	Jumper settings on the SINEC L1 submodule.....	5 - 93
	BT 777 bus terminal.....	5 - 93
	Connecting cable for point-to-point communication.....	5 - 94
5.8.7	Technical Specifications of the Interface Submodules .....	5 - 95
<b>6</b>	<b>Multiprocessor Operation/Coordinators.....</b>	<b>6 - 3</b>
6.1	Introduction .....	6 - 4
6.2	Starting the Multiprocessor Operation .....	6 - 5
	Procedure, overview .....	6 - 5
	Step 1.....	6 - 8
	Step 2.....	6 - 8
	Step 3.....	6 - 10
	Step 4.....	6 - 11
	Step 5.....	6 - 11
	Step 6.....	6 - 12
	Step 7.....	6 - 13
	Step 8.....	6 - 14
	Notes relating to multiprocessor start .....	6 - 14
6.3	Coordinator Modes .....	6 - 15
	The Stop state .....	6 - 15
	Startup.....	6 - 15
	Normal operation and Stop in the event of faults .....	6 - 15
	Test mode .....	6 - 16
6.4	923A Coordinator Module.....	6 - 17
6.4.1	Technical Description .....	6 - 17
	Application .....	6 - 17
	Design .....	6 - 17
	Principle of operation.....	6 - 18
6.4.2	Settings on the Coordinator .....	6 - 19
	User control.....	6 - 19
6.5	923C Coordinator Module.....	6 - 20
6.5.1	Technical Description .....	6 - 20
	Application .....	6 - 20
	Design .....	6 - 21
	Principle of operation.....	6 - 21
	PG multiplexer .....	6 - 24

6.5.2	Settings on the Coordinator . . . . .	6 - 25
	Indicators and controls . . . . .	6 - 25
	Mode switch . . . . .	6 - 25
	Setting the DIL switches. . . . .	6 - 26
	Jumpers to switch off the coordination signals . . . . .	6 - 29
	Fault register . . . . .	6 - 29
6.6	Technical Specifications of the Coordinators . . . . .	6 - 30
<b>7</b>	<b>Interface Modules . . . . .</b>	<b>7 - 3</b>
7.1	The 300 and 312 Interface Modules . . . . .	7 - 4
7.1.1	Indicators and Controls. . . . .	7 - 6
7.1.2	Modes/Jumper Assignments of the IM 300. . . . .	7 - 7
7.2	The 301 and 310 Interface Modules . . . . .	7 - 11
7.2.1	Indicators and Controls. . . . .	7 - 12
7.2.2	Modes/Jumper Assignments of the IM 301. . . . .	7 - 13
7.3	The 304 and 314 Interface Modules . . . . .	7 - 15
7.3.1	Indicators and Controls. . . . .	7 - 16
7.3.2	Modes/Jumper Assignments of the IM 304. . . . .	7 - 17
7.3.3	Modes/Jumper Assignments of the IM 314. . . . .	7 - 19
7.4	Technical Specifications . . . . .	7 - 22
7.4.1	6ES5 721 Connecting Cable. . . . .	7 - 23
7.4.2	6ES5 760 Terminator . . . . .	7 - 24
<b>8</b>	<b>Digital Input/Output Modules . . . . .</b>	<b>8 - 3</b>
8.1	Technical Description . . . . .	8 - 4
8.1.1	Design . . . . .	8 - 6
8.1.2	Function of the Enable Inputs . . . . .	8 - 6
8.1.3	Special Features of the 432 Digital Input Module. . . . .	8 - 10
	Operation without process alarm . . . . .	8 - 10
	Operation with process alarm via interrupt . . . . .	8 - 11
	Operation with process alarm via IB 0 . . . . .	8 - 12
8.1.4	Special Features of the DI/DQ 482 . . . . .	8 - 15
8.2	Installation and Startup . . . . .	8 - 17
8.2.1	Setting the Module Address . . . . .	8 - 17
8.2.2	Removing and Inserting Modules . . . . .	8 - 21
8.2.3	Marking of Modules . . . . .	8 - 23
8.2.4	Connecting the Signal Lines. . . . .	8 - 24
8.2.5	Connection of Outputs in Parallel and Switching On the Load via a Contact. . . . .	8 - 25
8.2.6	Short-Circuit Protection and Fusing. . . . .	8 - 27
8.2.7	Arc-Quenching for Inductive Loads. . . . .	8 - 28
8.3	Common Technical Specifications . . . . .	8 - 31

8.4	Specification Sheets for the Modules .....	8 - 33
8.4.1	6ES5 420-4UA13 Digital Input Module .....	8 - 33
8.4.2	6ES5 430-4UA13 Digital Input Module .....	8 - 35
8.4.3	6ES5 431-4UA12 Digital Input Module .....	8 - 37
8.4.4	6ES5 432-4UA12 Digital Input Module .....	8 - 39
8.4.5	6ES5 434-4UA12 Digital Input Module .....	8 - 42
8.4.6	6ES5 435-4UA12 Digital Input Module .....	8 - 45
8.4.7	6ES5 436-4UA12 Digital Input Module .....	8 - 47
8.4.8	6ES5 436-4UB12 Digital Input Module .....	8 - 49
8.4.9	6ES5 441-4UA13 Digital Output Module .....	8 - 51
8.4.10	6ES5 451-4UA13 Digital Output Module .....	8 - 53
8.4.11	6ES5 453-4UA12 Digital Output Module .....	8 - 55
8.4.12	6ES5 454-4UA13 Digital Output Module .....	8 - 57
8.4.13	6ES5 455-4UA12 Digital Output Module .....	8 - 59
8.4.14	6ES5 456-4UA12 Digital Output Module .....	8 - 61
8.4.15	6ES5 456-4UB12 Digital Output Module .....	8 - 63
8.4.16	6ES5 457-4UA12 Digital Output Module .....	8 - 65
8.4.17	6ES5 458-4UA12 Digital Output Module .....	8 - 67
8.4.18	6ES5 458-4UC11 Digital Output Module .....	8 - 70
8.4.19	6ES5 482-4UA11 Digital Input/Output Module .....	8 - 72
<b>9</b>	<b>Analog Input/Output Modules .....</b>	<b>9 - 3</b>
9.1	Technical Description .....	9 - 4
9.2	Common Technical Specifications .....	9 - 5
9.3	The 460 Analog Input Module .....	9 - 6
9.3.1	Design .....	9 - 6
9.3.2	Function of the Enable Input .....	9 - 6
9.3.3	Special Features of the 460 Analog Input Module .....	9 - 10
9.3.4	Setting the Module Address .....	9 - 12
9.3.5	Removing and Inserting Modules .....	9 - 15
9.3.6	Marking of Modules and Front Connectors .....	9 - 17
9.3.7	Connecting the Signal Lines .....	9 - 18
9.3.8	Connection of Sensors .....	9 - 19
9.3.9	Connecting a Compensating Box for Thermal E.M.F. Measurement .....	9 - 21
9.3.10	Connecting Resistance Thermometers in the Standard Pt 100 Range .....	9 - 22
9.3.11	Connecting Resistance Thermometers in the Extended Pt 100 Range .....	9 - 23
9.3.12	Broken Wire Signal .....	9 - 24
9.3.13	Connecting Transducers .....	9 - 25
9.3.14	Measured-Value Representation .....	9 - 26
9.3.15	Technical Specifications .....	9 - 31
9.4	The 463 Analog Input Module .....	9 - 37
9.4.1	Design .....	9 - 37
9.4.2	Function of the Enable Input .....	9 - 37
9.4.3	Special Features of the 463 Analog Input Module .....	9 - 40
9.4.4	Setting the Module Address .....	9 - 41
9.4.5	Removing and Inserting Modules .....	9 - 44
9.4.6	Marking of Modules and Front Connectors .....	9 - 46
9.4.7	Connecting the Signal Lines .....	9 - 47

9.4.8	Measured-Value Representation .....	9 - 48
9.4.9	Technical Specifications .....	9 - 49
9.5	The 465 Analog Input Module .....	9 - 53
9.5.1	Design .....	9 - 53
9.5.2	Function of the Enable Input .....	9 - 53
9.5.3	Special Features of the 465 Analog Input Module .....	9 - 57
9.5.4	Setting the Module Address .....	9 - 59
9.5.5	Removing and Inserting Modules .....	9 - 62
9.5.6	Marking of Modules and Front Connectors.....	9 - 64
9.5.7	Connecting the Signal Lines.....	9 - 65
9.5.8	Connecting a Compensating Box for Thermal E.M.F. Measurement.....	9 - 66
9.5.9	Connecting Resistance Thermometers to the 465 Analog Input Module.....	9 - 67
9.5.10	Broken Wire Signal for Resistance Thermometers .....	9 - 69
9.5.11	Connecting Transducers .....	9 - 70
9.5.12	Measured-Value Representation .....	9 - 71
9.5.13	Technical Specifications .....	9 - 75
9.6	The 466 Analog Input Module .....	9 - 81
9.6.1	Design .....	9 - 81
9.6.2	Special Features of the 466 Analog Input Module .....	9 - 81
9.6.3	Startup .....	9 - 81
9.6.4	Removing and Inserting Modules .....	9 - 88
9.6.5	Marking of Modules and Front Connectors.....	9 - 90
9.6.6	Connecting the Signal Lines.....	9 - 91
9.6.7	Connecting Sensors to the 466 Analog Input Module.....	9 - 92
9.6.8	Measured-Value Representation .....	9 - 95
9.6.9	Technical Specifications .....	9 - 99
9.7	The 470 Analog Output Module .....	9 - 103
9.7.1	Design .....	9 - 103
9.7.2	Function of the Enable Input .....	9 - 103
9.7.3	Special Features of the 470 Analog Output Module .....	9 - 107
9.7.4	Setting the Module Address .....	9 - 107
9.7.5	Removing and Inserting Modules .....	9 - 110
9.7.6	Marking of Modules and Front Connectors.....	9 - 112
9.7.7	Connecting the Signal Lines.....	9 - 113
9.7.8	Connecting Loads to the 470 Analog Output Module.....	9 - 114
9.7.9	Measured-Value Representation .....	9 - 116
9.7.10	Technical Specifications .....	9 - 117
<b>10</b>	<b>Connector Assignments.....</b>	<b>10 - 1</b>
<b>11</b>	<b>Appendix.....</b>	<b>11 - 1</b>
	Ordering Information.....	11 - 3
	Further Reading .....	11 - 11
<b>12</b>	<b>Index .....</b>	<b>12 - 1</b>

# Notes on Using this Manual

# 1

The S5-135U/155U PLC is a member of the family of SIMATIC S5 programmable (logic) controllers. The controller can be used in single and in multiprocessor operation with up to four CPUs. In multiprocessor operation, each CPU processes its individual user program independently of the other CPUs (multi-computing).

## *CPUs available*

The following are available as CPUs:

<b>CPU 948</b>	for fast word and binary signal processing, especially fast double-word and floating point processing, and for large programs with a high storage requirement; programming in STEP 5. When you use a CPU 948, you have an S5-155U PLC.
<b>CPU 928B</b>	for fast word and binary signal processing and for communication; programming in STEP 5.
<b>CPU 928</b>	for fast binary signal processing and for word processing; programming in STEP 5.
<b>CPU 922 (R processor)</b>	for word processing (computing, controlling, monitoring, signalling); programming in STEP 5.

## *Slots*

You can combine the CPUs arbitrarily at the CPU slots in the central controller:

<b>CPU</b>	<b>Slot Requirement</b>
CPU 948/CPU 928B/CPU 928	2 slots
CPU 922	1 slot



Given as a guide in the following are pointers on how this manual is organized; they will assist you when using your S5-135U/155U programmable controller.

- At the end of this manual you will find the "**ESD Guidelines.**" You must observe these to the letter and follow them during the entire time you are working with the S5-135U/155U PLC. If your PLC requires repair, you must observe the Repair Guidelines in Section 4.1.4.
- **Chapter 3** contains the Installation Guidelines with information on interference-free installation of the S5-135U/155U PLC.

Which of the remaining chapters of this manual you may require when working with your PLC will depend on the extent of your automation task and on the configuration of your PLC.

For a basic configuration in single-processor operation without expansion units, you will need the following chapters:

- **Chapter 4** describes the central controller (CC) in Section 4.1. Described are the technical features, installation, startup and maintenance of the CC. Section 4.3 describes the power supply units. You will find a separate description of the 6ES5 955-3NA12 power supply unit in Section 4.5. Both sections describe the installation and startup as well as the necessary maintenance on the power supply units. The 24 V/4 A load power supply is described in Section 4.4.
- **Chapter 5** contains the instructions for the individual CPUs. Described here are the technical features, installation and startup of the individual CPUs. The various methods of operating the CPUs are also described, as are the CPU statuses where they can be directly indicated by the LEDs on the module. If you use memory submodules or memory cards (CPU 948), you can look up the necessary information in Sections 5.5 to 5.7.
- **Chapter 8** and **Chapter 9** describe the digital and analog I/O modules. Described here are the installation, wiring and operation of these modules. Individual I/O modules exhibit specific features which are discussed in separate chapters.

To configure your PLC with expansion units (EUs) you will need the following chapters:

- **Chapter 2** shows how you can configure a PLC with expansion units in a centralized or distributed arrangement.
- Described in **Chapter 4**, Section 4.2, are the EU 183U, EU 184U, EU 185U and EU 187U. Those EUs which operate with their own power supply unit are described in Section 4.3.
- **Chapter 7** describes the interface modules (IMs) which serve for data communication between central controllers and expansion units.

To operate two or more CPUs in multiprocessor mode in your PLC, you will need Chapter 6.

- **Chapter 6** describes multiprocessor operation. This chapter contains all the measures you must take for startup of the PLC in multiprocessor operation. Described in Sections 6.5 and 6.6 are the 923C and 923A coordinators.

Given in the **Chapter 10** are the connector assignments of the individual modules and subracks.

**Chapter 11** contains ordering data for the product described in this manual and references to further reading.

**Chapter 12** contains the **Index** of keywords in this manual.

# 2

## Centralized and Distributed Configuration of a Programmable Controller

### Contents of Chapter 2

2	Centralized and Distributed Configuration of a Programmable Controller . . . . .	2 - 3
2.1	Application . . . . .	2 - 4
2.2	Centralized and Distributed Configuration . . . . .	2 - 5
2.2.1	Installing a PLC with Centralized Configuration . . . . .	2 - 6
2.2.2	Installing a PLC with Distributed Configuration . . . . .	2 - 7
2.3	Examples . . . . .	2 - 9

# Centralized and Distributed Configuration of a Programmable Controller

## 2

This chapter contains an overview of the methods of configuring an S5-135U/155U PLC. You will find a description of the types of communication between a central controller and the expansion units, and an overview of the interface modules required for the different types of communication.

## 2.1 Application

The S5-135U/155U programmable controllers comprise a central controller (CC) and, if required, one or more expansion units (EUs). You need EUs when there are insufficient slots in the CC for the modules to be used.

Various interface modules (IMs) are available for communication between the CC and the EUs and between the EUs. It is therefore possible to install an EU or EUs in the immediate vicinity of the CC (centralized configuration) or at some distance (distributed configuration). A combination of both types of configuration is also possible by connecting additional EUs in a centralized configuration with a distributed EU (see Figure 2-6).

This is clarified on the following pages.

## 2.2 Centralized and Distributed Configuration

You can install a PLC in centralized or distributed configuration according to your application.

**2**

IF...	THEN...
you wish to position the modules as closely as possible to the CC and can accept longer cable runs to the process,	choose the centralized configuration
you wish to position the I/O modules as closely as possible to the process and can accept longer cable runs to the CC,	choose the distributed configuration.

With the centralized configuration, you can install the CC and EUs in the same cabinet or in adjacent cabinets. Data transmission is parallel. Shown in the following figure is a centralized configuration.

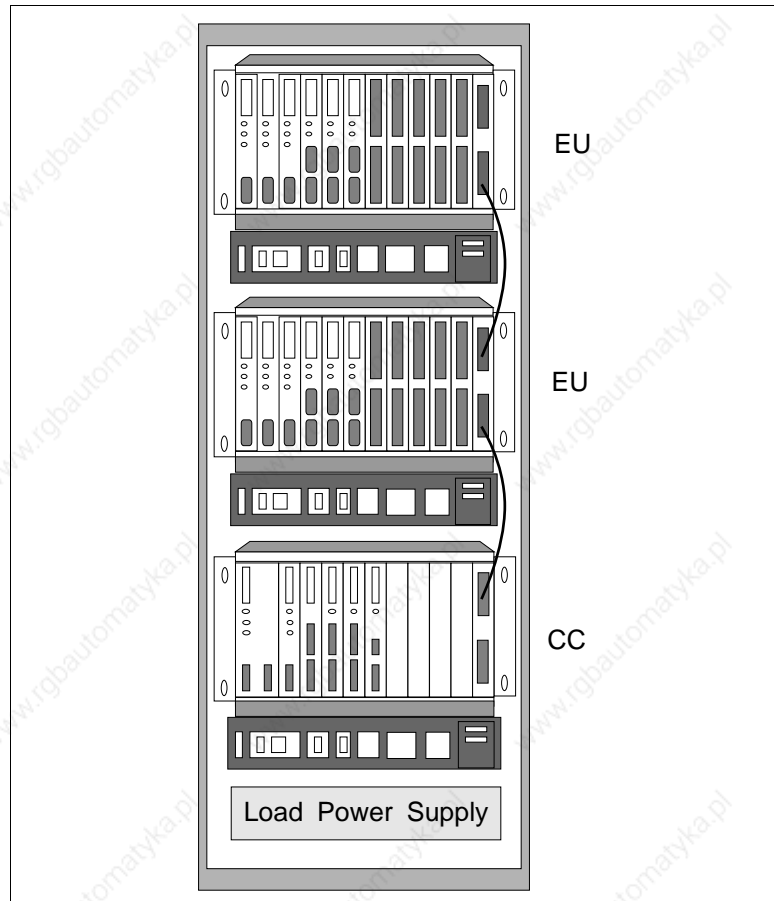

Figure 2-1 Centralized Configuration



To install a PLC in a centralized configuration, you must observe the following conditions:

- A centralized configuration is generally only suitable for connecting I/O modules (DI, DQ, AI, AQ) and some intelligent I/O modules (IPs) in the EU (see the Configuring Aids in the catalog and Chapter 4).
- The line length between the IM in the CC and the last IM in the EU must not exceed 2 m.

### 2.2.2

#### Installing a PLC with Distributed Configuration

To install a PLC in a distributed configuration, you have a choice of parallel/symmetrical and serial communication. The following table shows which interfaces and connecting cables can be used to connect the various expansion units (EUs/ERs) to the CC in a distributed configuration.

Interface Module in the CC	Expansion Unit	Interface Module in the EU	Connecting Cable Max. Permissible Line Length
IM 301-3 6ES5 301-3AB13 (not for S5-155H)	EU 183U ER 701-2 ER 701-3	IM 310 <sup>1)</sup> 6ES5 310-3AB11	6ES5 721-0xxxx 1 m to 200 m
IM 301-5 6ES5 301-5CA12	EU 183U EU 185U	IM 310 <sup>1)</sup> 6ES5 310-3AB11	
IM 304 6ES5 304-3UB11	ER 701-2 ER 701-3 EU 183U EU 185U	IM 314 <sup>1)</sup> 6ES5 314-3UA11	6ES5 721-0xxxx 1 m to 600 m
IM 308 6ES5 308-3UA12	ER 701-2 ER 701-3 EU 183U EU 185U	IM 318-3 6ES5 318-3UA11	6ES5 707-5AA00 V45551-F21-B5 up to 3000 m
	ET 100U (Catalog ST 52.1)	IM 318-8 6ES5 318-8MA12	
	ICM 560	-	
IM 308-B 6ES5 308-3UB11	ET 200	IM 318-B 6ES5 318-8MB11	Cable connection
IM 307 6ES5 307-3UA11	ER 701-2 ER 701-3	IM 317 6ES5 317-3UA11	6ES5 722-2xxxx Fiber optic cable up to 1500 m
	EU 183U EU 185U	IM 317 6ES5 317-3UA11	

<sup>1)</sup> The last IM 310 or IM 314 always requires a 6ES5 760-1AA11 terminator.

The ER 701-2 and ER 701-3 always additionally require an IM 306 for communication via an IM 304, IM 307 or IM 308.

To install a PLC in a distributed configuration, you must observe the following conditions:



- With the IM 301/IM 310 pair of interface modules, you can only use I/O modules (DI, DQ, AI, AQ) and IPs without page addressing in the EUs.
- With the IM 304/314 pair of interface modules, you can use all IPs, CPs and I/O modules in the EU 185U.

**Note**

The IM 307/317, IM 308/318 and IM 308-B/318-B each have their own manual (see catalog).

## 2.3 Examples

Given in the following are some examples of centralized and distributed configuration of various SIMATIC S5 components.

2

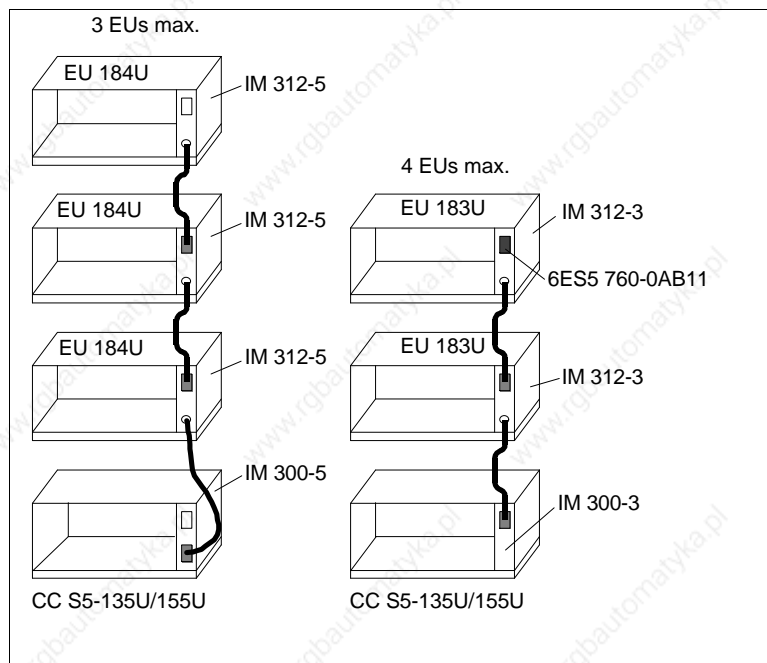

Figure 2-2 Centralized Configuration of an S5-135U/155U with the IM 300 and IM 312

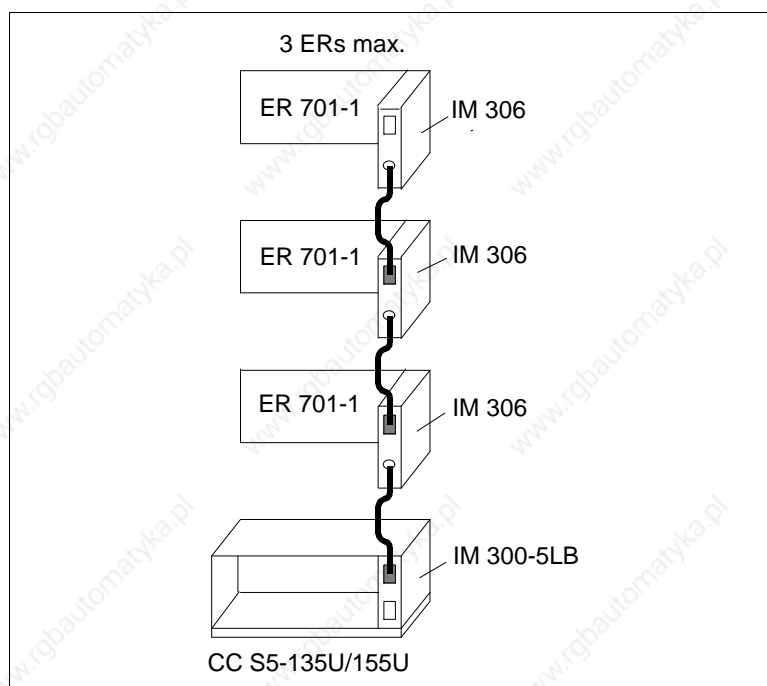

Figure 2-3 Centralized Configuration of an S5-135U/155U with ERs 701

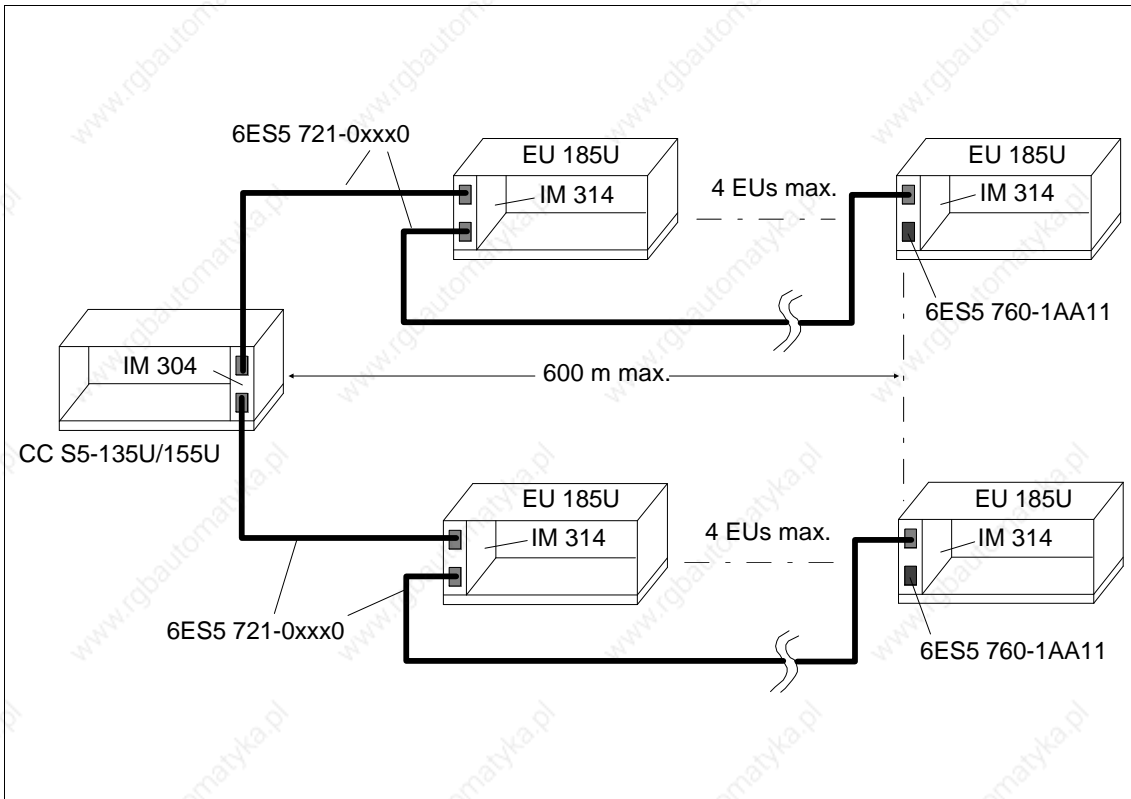

Figure 2-4 Distributed Configuration of an S5-135U/155U with the IM 304 and IM 314

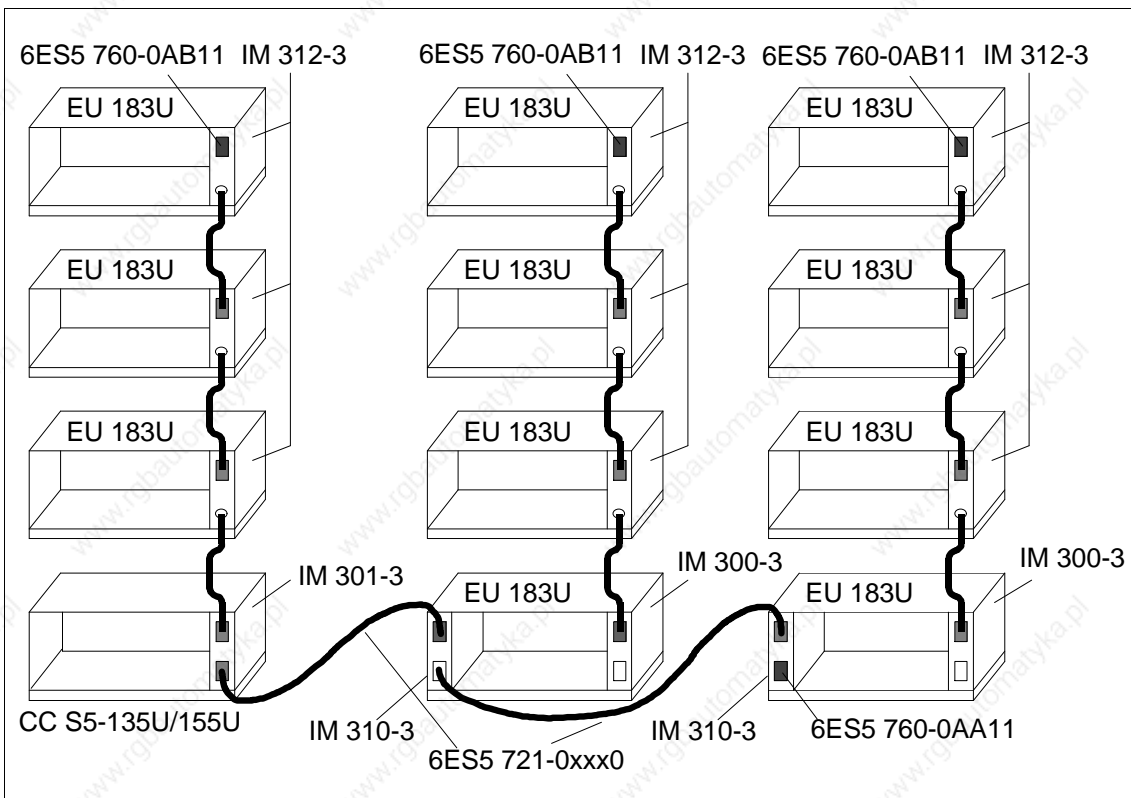

Figure 2-5 Distributed Configuration of an S5-135U/155U with Expansion Units in Centralized Configuration

# Installation Guidelines

# 3

## Contents of Chapter 3

3	Installation Guidelines .....	3 - 3
3.1	Principles of Installation of Systems for EMC .....	3 - 4
3.1.1	Overview of Possible Interference.....	3 - 4
3.1.2	The Most Important Basic Rules for Ensuring EMC .....	3 - 7
3.2	Installation of Programmable Controllers for EMC .....	3 - 9
3.2.1	Basic Rules for Assembling and Grounding the Inactive Metal Parts .....	3 - 9
3.2.2	Example of Cabinet Assembly for EMC.....	3 - 10
3.2.3	Example of Rack and Wall Mounting for EMC .....	3 - 12
3.3	Wiring of Programmable Controllers for EMC.....	3 - 14
3.3.1	Routing of Cables.....	3 - 14
3.3.2	Equipotential Bonding .....	3 - 16
3.3.3	Shielding of Cables and Lines .....	3 - 17
3.3.4	Special Measures for Interference-Free Operation .....	3 - 19
	AC power connection for programmers.....	3 - 20
	Cabinet lighting.....	3 - 20
3.3.5	Checklist for the Electromagnetically Compatible Installation of Control Systems ...	3 - 21
3.4	Power Supplies for Programmable Controllers and I/Os .....	3 - 22
3.4.1	Power Supplies for Control Systems with SIMATIC S5 .....	3 - 22
3.4.2	Connecting the Programmable Controller and Load Power Supply.....	3 - 23
3.4.3	Connecting Non-Floating or Floating Modules.....	3 - 28
3.5	Interference-Free Installation of Centralized and Distributed Interface Circuits .....	3 - 30
3.5.1	Interference-Free Installation of Centralized Interface Circuits .....	3 - 30
3.5.2	Interference-Free Installation of Distributed Interface Circuits .....	3 - 30

3.6	Interference-Free Connection of Monitors. . . . .	3 - 32
3.6.1	Interference-Free Connection of a Monitor to the CP of the S5 Controller. . . . .	3 - 32
3.6.2	Shielding and Grounding . . . . .	3 - 33
3.7	Selection and Installation of Cabinets with SIMATIC S5 . . . . .	3 - 35
3.7.1	Types of Cabinet. . . . .	3 - 36
3.7.2	Clearances in Cabinets . . . . .	3 - 36
3.7.3	Removal of Power Dissipation from Cabinets . . . . .	3 - 39
3.7.4	Examples for Determining the Type of Cabinet . . . . .	3 - 40
3.7.5	Determining the Power Dissipation of Modules. . . . .	3 - 41

# Installation Guidelines

# 3

# 3

The Installation Guidelines provide you with information for the interference-free installation of the SIMATIC S5-135U/155U programmable controllers.

This chapter describes the following:

- Paths which serve for interference pickup in programmable controllers, and five rules for ensuring electromagnetic compatibility (EMC)
- Interference-free installation of the programmable controllers
- Cable routing, the connecting of cable shields and equipotential bonding between equipment
- The power supplies for control and load circuits, and the different grounding concepts
- Shielding and grounding for the connection of centralized and distributed expansions and monitors to programmable controllers
- The selection and design of cabinets

### 3.1 Principles of Installation of Systems for EMC

What does EMC mean?

Electromagnetic compatibility (EMC) is understood to mean the capability of electrical equipment to operate correctly in a defined electromagnetic environment, without being affected by the environment and without affecting the environment to an unacceptable degree.

All SIMATIC S5 products have been developed for applications in harsh industrial environments and meet high requirements for EMC. Before installing the control system, however, you should still carry out EMC planning and involve possible interference sources in the assessment.

Described in the following chapter are

- the various paths over which interference can be picked up in the PLC;
- typical interference sources and their coupling mechanisms,
- basic rules for ensuring EMC.

#### 3.1.1 Overview of Possible Interference

Electromagnetic interference can be picked up over different paths by the programmable controller:

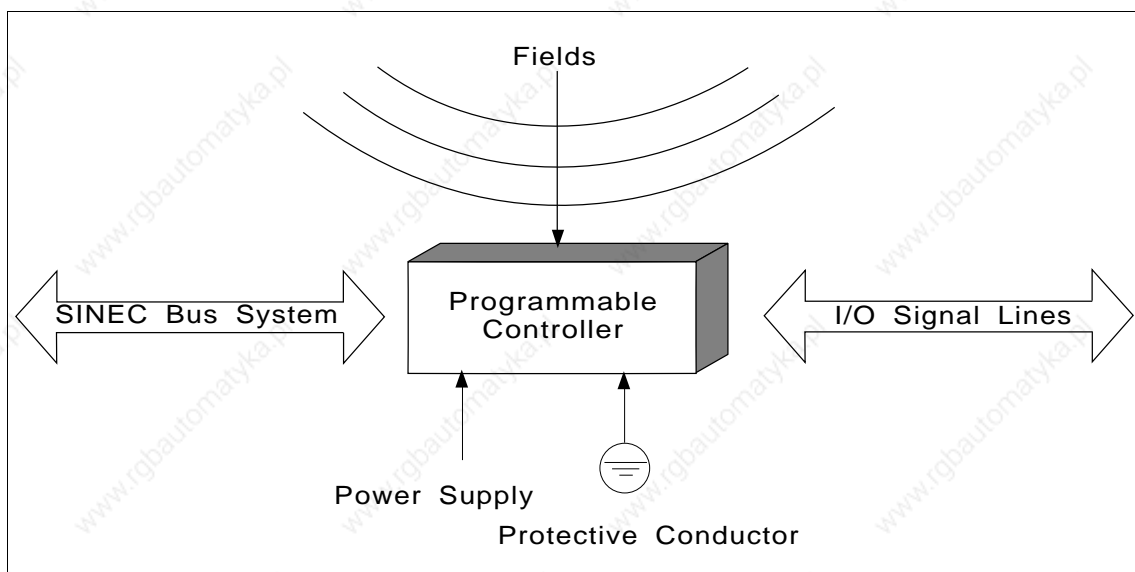

Figure 3-1 Electromagnetic Interference with Programmable Controllers

Depending on the propagation medium (conducted or non-conducted interference) and distance from the source, interference can be picked up by the programmable controller via different coupling mechanisms.

A distinction is made between the following:

- Direct coupling
- Capacitive coupling
- Inductive coupling
- Radiated interference



*Coupling mechanisms and typical interference sources at a glance*

Shown in the following table are the four different coupling mechanisms, their causes and possible interference sources.

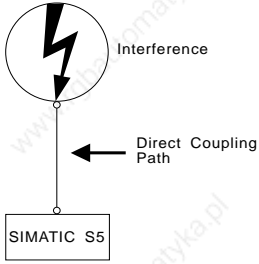
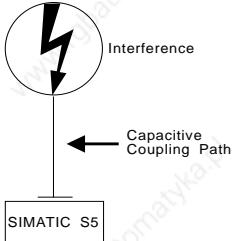
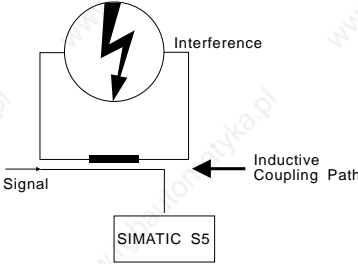
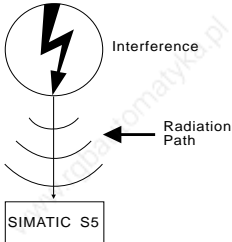
Coupling Mechanism	Cause	Typical Interference Sources
<ul style="list-style-type: none"> <li>Direct Coupling</li> </ul> 	<p>Direct or metallic coupling always occurs when two circuits have a common conductor.</p>	<ul style="list-style-type: none"> <li>Switched devices (supply affected by inverters and external power supply units)</li> <li>Motors being started</li> <li>Different potentials of component cases with a common power supply</li> <li>Static discharges</li> </ul>
<ul style="list-style-type: none"> <li>Capacitive Coupling</li> </ul> 	<p>Capacitive or electrical coupling occurs between conductors which are at different potentials.</p> <p>The degree of coupling is proportional to the voltage variation as a function of time.</p>	<ul style="list-style-type: none"> <li>Interference pickup via parallel signal cables</li> <li>Static discharge of the operator</li> <li>Contactors</li> </ul>
<ul style="list-style-type: none"> <li>Inductive Coupling</li> </ul> 	<p>Inductive or magnetic coupling occurs between two conductor loops through which current is flowing. Interference voltages are induced by the magnetic fluxes associated with the currents. The degree of coupling is proportional to the current variation as a function of time.</p>	<ul style="list-style-type: none"> <li>Transformers, motors, electric welders</li> <li>Parallel AC supply cables</li> <li>Cables whose currents are switched</li> <li>Signal cables with a high frequency</li> <li>Unconnected coils</li> </ul>
<ul style="list-style-type: none"> <li>Radiated Interference</li> </ul> 	<p>There is a radiation path when a conductor is subjected to an electromagnetic wave. Impinging of the wave results in induced currents and voltages.</p>	<ul style="list-style-type: none"> <li>Local transmitters (e.g. two-way radios)</li> <li>Spark gaps (spark plugs, collectors of electric motors, welders)</li> </ul>

### 3.1.2

#### The Most Important Basic Rules for Ensuring EMC

It is often sufficient to comply with a few elementary rules for ensuring EMC. When installing the control system, therefore, observe the following five basic rules.

**When installing the programmable controllers, provide large-area good quality grounding of the inactive metal parts (see Section 3.2).**

- Make a large-area low-impedance interconnection of all inactive metal parts.
- For screw connections on painted and anodized metal parts, either use special contact washers or remove the insulating protective layers.
- If possible, do not use aluminium parts. Aluminum oxidizes easily and is therefore less suitable for grounding.
- Make a central connection between the chassis ground and the ground/protective ground conductor system.

**Ensure proper routing of lines when wiring (see Sections 3.3.1 and 3.3.2).**

- Arrange the cabling in line groups.  
(AC power cable, power supply lines, signal lines, data lines)
- Always install AC power cables and signal or data lines in separate ducts or bunches.
- Route the signal and data lines as closely as possible to grounded surfaces such as cabinet elements, metal bars and cabinet panels.

**Ensure that cable shields are properly secured (see Section 3.3.3).**

- Data lines must be shielded. The shield should be connected at both ends.
- Analog lines must be shielded. For the transfer of signals with low amplitudes, it may be advisable to connect the shield at only one end.

- Provide the line shields with a large-area connection to a shield/protective conductor bar immediately after the cabinet inlet, and secure the shields with cable clamps. Route the grounded shield as far as the module without interruption, but do not connect the shield there again.
- Ensure that the shield/protective ground bar has a low-impedance connection to the cabinet.
- Use metal or metallized connector cases for shielded data lines.

**Employ special EMC measures for particular applications (see Section 3.3.4).**

- Fit quenching elements to all inductances which are not controlled by SIMATIC S5 modules.
- Use incandescent bulbs for illuminating cabinets, and avoid fluorescent lamps.

**Create a standard reference potential; ground all electrical apparatus if possible (see Sections 3.4 and 3.5).**

- Use specific grounding measures. Grounding of the control system is a protective and functional measure.
- System parts and cabinets with central controllers and expansion units should be connected to the ground/protective conductor system in star configuration. This serves to avoid the creation of ground loops.
- In the case of potential differences between system parts and cabinets, install equipotential bonding conductors of sufficient rating.

## 3.2 Installation of Programmable Controllers for EMC

Measures for suppressing interference voltages are often applied only when the control system is already operational and proper reception of a useful signal is impaired. The reason for such interference is usually inadequate reference potentials caused by mistakes in equipment assembly. Described in the following sections are:

- Basic rules for grounding the inactive metal parts
- Examples of cabinet assembly for EMC
- Example of rack and wall mounting for EMC

3

### 3.2.1

#### Basic Rules for Assembling and Grounding the Inactive Metal Parts

Ensure wide-area chassis grounding of the inactive metal parts when mounting the equipment. Properly implemented grounding creates a uniform reference potential for the control system, and reduces the effects of picked-up interference.

Chassis grounding is understood to mean the electrical connection of all inactive parts. The entirety of all interconnected inactive parts is the chassis ground.

Inactive parts are conductive parts which are electrically isolated from active parts by basic insulation, and can only develop a voltage in the event of a fault.

The chassis ground **must not develop a dangerous touch voltage**, even in the event of a fault. The ground must therefore be connected to the protective ground conductor. To prevent ground loops, locally separated ground elements such as cabinets, structural and machine parts, must always be connected to the protective ground system in star configuration.

Ensure the following when chassis grounding:

- Connect the inactive metal parts with the same degree of care as the active parts.
- Ensure low-impedance metal-to-metal connections, e.g. with large-area good quality contact.
- When you are incorporating painted or anodized metal parts in the grounding, these insulating protective layers must be penetrated. Use special contact washers or remove the insulating layer.
- Protect the connection points from corrosion, e.g. with grease.
- Movable grounded parts such as cabinet doors must be connected via flexible grounding strips. The grounding strips should be short and have a large surface because the surface is decisive in providing a path to ground for high-frequency interference.

**3.2.2  
Example of Cabinet  
Assembly for EMC**

The example of cabinet assembly in the figure shows the various measures, the grounding of inactive metal parts and the connection of shielded cables. This example applies only to grounded operation. Follow the points numbered in the figure during assembly.

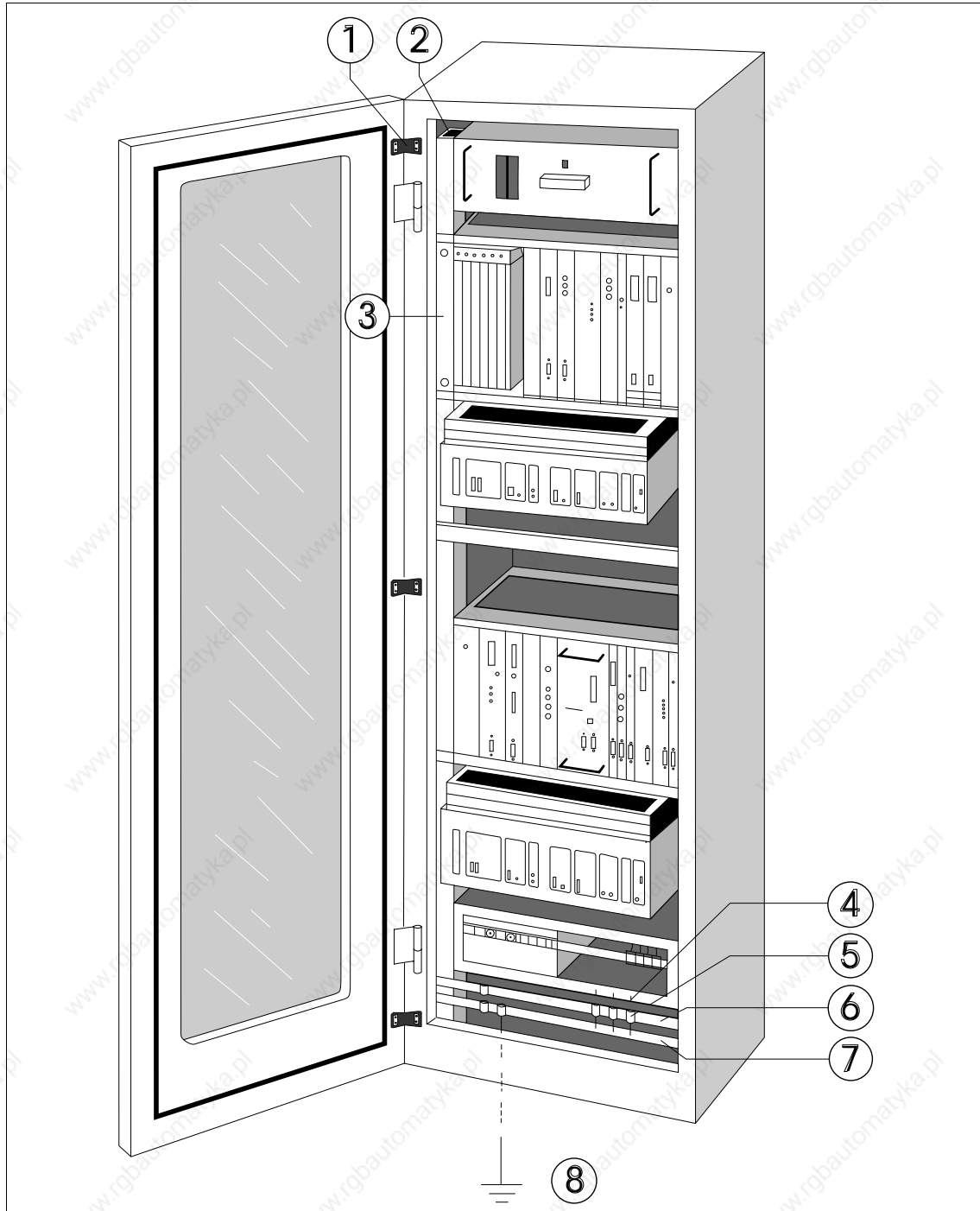

Figure 3-2 Example of Cabinet Assembly for EMC

① **Grounding strips**

If there are no large-area metal-to-metal connections, you must connect inactive metal parts such as cabinet doors and supports with grounding strips. These should be short and have a large surface.

② **Cabinet members**

The cabinet members should have a large-area connection to the cabinet housing (metal-to-metal connection).

③ **Mounting bracket for subrack**

There must be a large-area metal-to-metal connection between cabinet member and mounting bracket.

④ **Signal lines**

With shielded signal lines, the shield must be secured to the protective conductor bar or an additionally fitted shield bar using large-area cable clamps.

⑤ **Cable clamp**

The cable clamp must enclose and make contact with the shield braid over a large area.

⑥ **Shield bar**

This bar must have a large-area connection to the cabinet members (metal-to-metal connection). It serves for grounding the cable shields.

⑦ **Protective conductor bar**

The protective conductor bar must have a large-area connection to the cabinet members (metal-to-metal connection). The protective conductor bar must be connected to the protective conductor system via an external conductor (at least 10 mm<sup>2</sup>). This is essential for providing a reliable path to ground for fault currents and interference currents.

⑧ **Conductor to the protective conductor system (ground point)**

The conductor must have a large-area connection to the protective conductor system (ground point).

### 3.2.3

#### **Example of Rack and Wall Mounting for EMC**

To operate your control system in a low-interference environment whilst observing the permissible ambient conditions (see "Technical Specifications"), you can mount the programmable controllers on racks or directly on walls.

Picked-up interference should be given a path to large metal surfaces. You should therefore secure standard sectional rails, shield and protective conductor bars to metal structural elements. For wall mounting in particular, installation on reference potential surfaces made of sheet steel has proved advantageous.

When installing shielded cables, provide a shield bar for connecting the cable shields. The shield bar can also be the protective conductor bar.

Ensure the following for rack and wall mounting:

- Suitable contacting aids should be used on painted and anodized metal parts. Use special contact washers or remove the insulating protective layers.
- Provide large-area, low-impedance metal-to-metal connections when securing the shield/protective conductor bar.
- AC conductors must be covered.

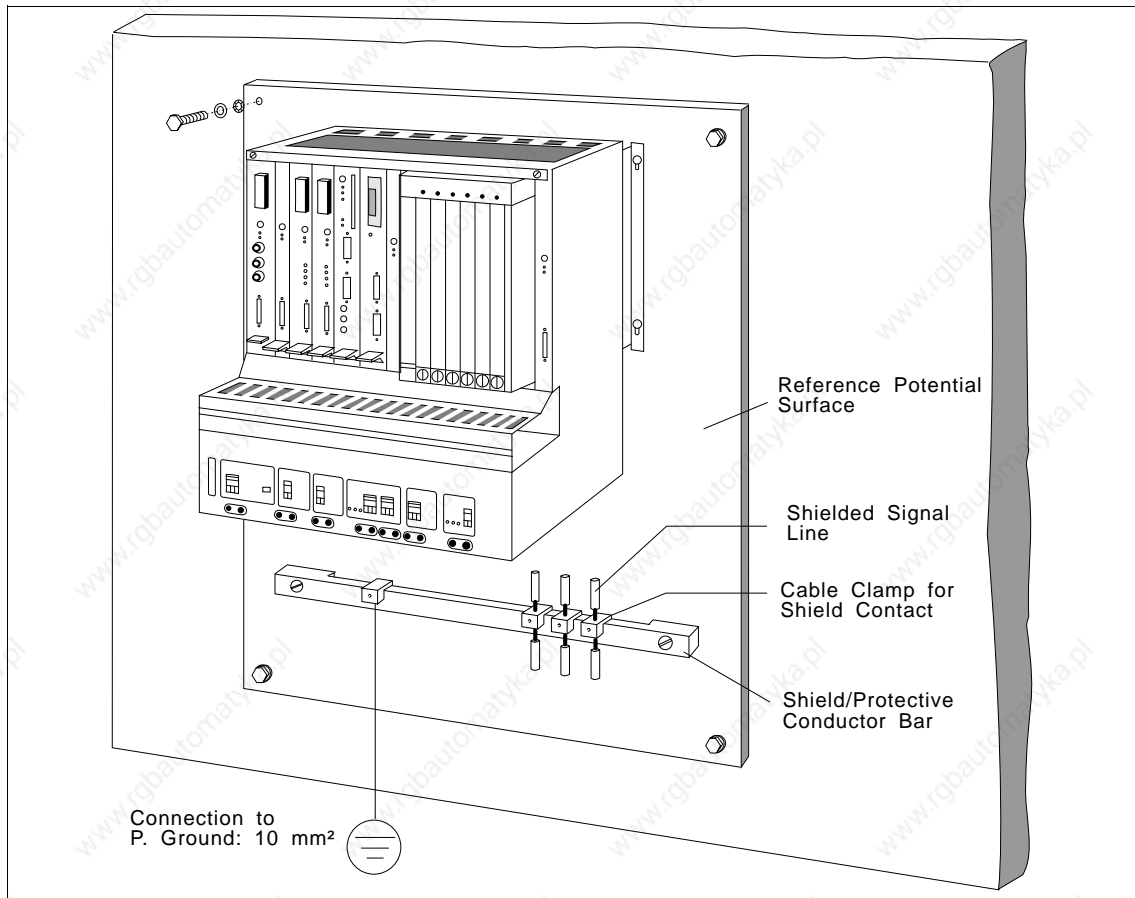

3

Figure 3-3 Wall Mounting of an S5-135U/155U PLC



### 3.3 Wiring of Programmable Controllers for EMC

The following section describes:

- Routing of cables within and outside cabinets
- Equipotential bonding between devices
- Single and double-ended connection of cable shields
- Checklist for electromagnetically compatible installation

#### 3.3.1 Routing of Cables

This section covers the routing of bus, signal and supply lines. The purpose cable routing is to suppress crosstalk between cables laid in parallel.

##### **Routing of cables within and outside cabinets**

For electromagnetically compatible routing of cables and lines, it is expedient to subdivide the lines into the following line groups and lay the groups separately.

##### *Group A*

- Shielded bus and data lines (for programmer, OP, SINEC L1, SINEC L2, printer, etc.)
- Shielded analog lines
- Unshielded lines for DC voltage  $\leq 60$  V
- Unshielded lines for AC voltage  $\leq 25$  V
- Coaxial cables for monitors

##### *Group B*

- Unshielded lines for DC voltage  $> 60$  V and  $\leq 400$  V
- Unshielded lines for AC voltage  $> 25$  V and  $\leq 400$  V

##### *Group C*

- Unshielded lines for DC and AC voltage  $> 400$  V

##### *Group D*

- Lines for SINEC H1

From the combination of individual groups in the following table, you can read off the conditions for laying the line groups.

	<b>Group A</b>	<b>Group B</b>	<b>Group C</b>	<b>Group D</b>
<b>Group A</b>	①	②	③	④
<b>Group B</b>	②	①	③	④
<b>Group C</b>	③	③	①	④
<b>Group D</b>	④	④	④	①

**Legend for the table**

①	Lines can be laid in common bundles or cable ducts.
②	Lines must be laid in separate bundles or cable ducts (without minimum clearance).
③	Lines within cabinets must be laid in separate bundles or cable ducts; outside the cabinets but within buildings, they must be laid over separate cable routes with a clearance of at least 10 cm.
④	Lines must be laid in separate bundles or cable ducts with a clearance of at least 50 cm.

**Routing of cables outside buildings**

Outside buildings, lay the lines on metal cable trays if possible. Provide the joints between cable trays with an electrical connection and ground the cable trays.

When laying lines outside buildings, you must observe the valid lightning protection and grounding measures. The following applies in general:

**Lightning protection****Caution**

Where cables and lines for SIMATIC S5 controllers are to be laid outside buildings, you must apply measures for internal and external lightning protection.

Outside the buildings, lay your lines either

- in metal conduit grounded at both ends,  
or
- in concreted cable ducts with continuously connected reinforcement.

Protect the signal lines from overvoltages by means of

- varistors  
or
- inert gas-filled surge diverters.

Fit these protective devices at the cable entry into the building.

**Note**

Lightning protection measures always require an individual assessment of the entire installation. For clarification, please consult your Siemens regional office or a company specializing in lightning protection.

**Equipotential bonding**

Ensure adequate equipotential bonding between the connected equipment (see Section 3.3.2).

### 3.3.2 Equipotential Bonding

Between separate sections of an installation, potential differences can develop if

- programmable controllers and I/O devices are connected via a non-floating link, or
- cable shields are connected at both ends and are grounded at different parts of the system.

Different AC supplies, for example, can cause potential differences. These differences must be reduced by installing equipotential bonding conductors to ensure functioning of the electronic components.

The following points must be observed for equipotential bonding:

- The lower the impedance of the equipotential bonding conductor, the greater is the effectiveness of equipotential bonding.
- Where shielded signal lines are laid between the relevant sections of the system and connected at both ends to the ground/protective conductor, the impedance of the additional equipotential bonding conductor must not exceed 10 % of the shield impedance.
- The cross-section of the equipotential bonding conductor must be rated for the maximum circulating current. The following cross-sections of copper have proved to be satisfactory in practice:
  - 16 m<sup>2</sup> of copper for equipotential bonding conductors of up to 200 m in length
  - 25 m<sup>2</sup> of copper for equipotential bonding conductors of more than 200 m in length
- Use copper or zinc-plated steel for equipotential bonding conductors. They must be given a large-area connection to the ground/protective conductor and protect it from corrosion.
- The equipotential bonding conductor should be laid so that the smallest possible areas are enclosed between the equipotential bonding conductor and signal lines.

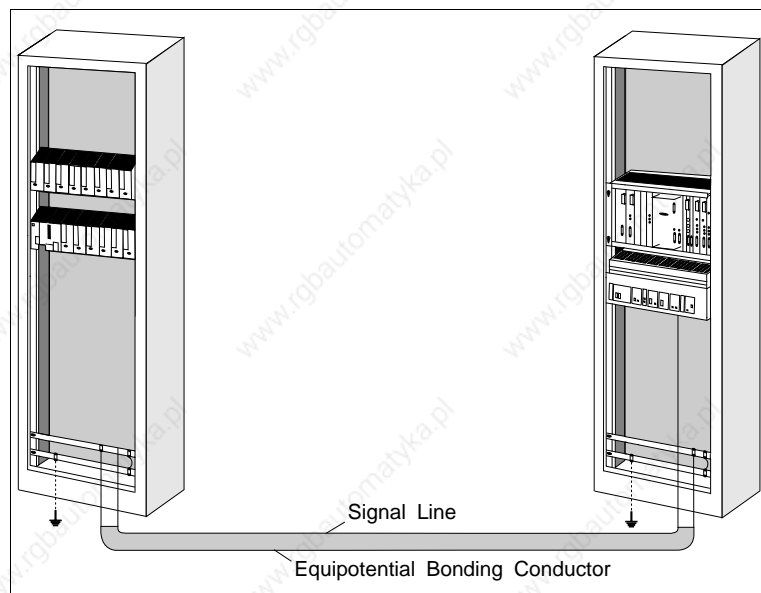

Figure 3-4 Routing of Equipotential Bonding Conductor and Signal Line

### 3.3.3 Shielding of Cables and Lines

Shielding is a method of attenuating magnetic, electrical or electro-magnetic interference fields.

Interference currents on cable shields are given a path to ground via the shield bar which is electrically connected to the housing. A low-impedance connection to the protective conductor is particularly important so that these interference currents themselves do not become an interference source.

Where possible, only use lines with a braided shield. The coverage density of the shield should be more than 80 %. Avoid lines with a foil shield because the foil can be very easily damaged by tensile strain and compression during fitting; this results in reduced effectiveness of the shield.

As a rule, line shields should always be connected at both ends. This is the only way to achieve a good degree of interference suppression in the higher frequency region.

Only in exceptional cases should the shield be connected at one end only, as this only achieves attenuation of the low frequencies. Single-ended shield connection may be more advantageous when:

- an equipotential bonding conductor cannot be laid;
- analog signals (of a few mV or  $\mu\text{A}$ ) are to be transmitted;
- foil (static) shields are used.

With data lines for serial communication, always use metal or metallized connectors. Secure the shield of the data line to the connector case. Do **not** connect the shield to Pin 1 of the connector.

For stationary operation, it is advisable to fully strip the insulation from the shielded cable and connect it to the shield/protective conductor bar.

#### Note

In the event of potential differences between ground points, a circulating current may flow through the shield connected at both ends. In this case, install an additional equipotential bonding conductor (see Section 3.3.2).

Please observe the following points when connecting the shield:

- Use metal cable clamps for securing the braided shield. The clamps must enclose the shield over a large area and provide a good contact.
- Connect the shield to a shield bar immediately after the cable entry into the cabinet. Route the shield as far as the module but do not connect it there again.

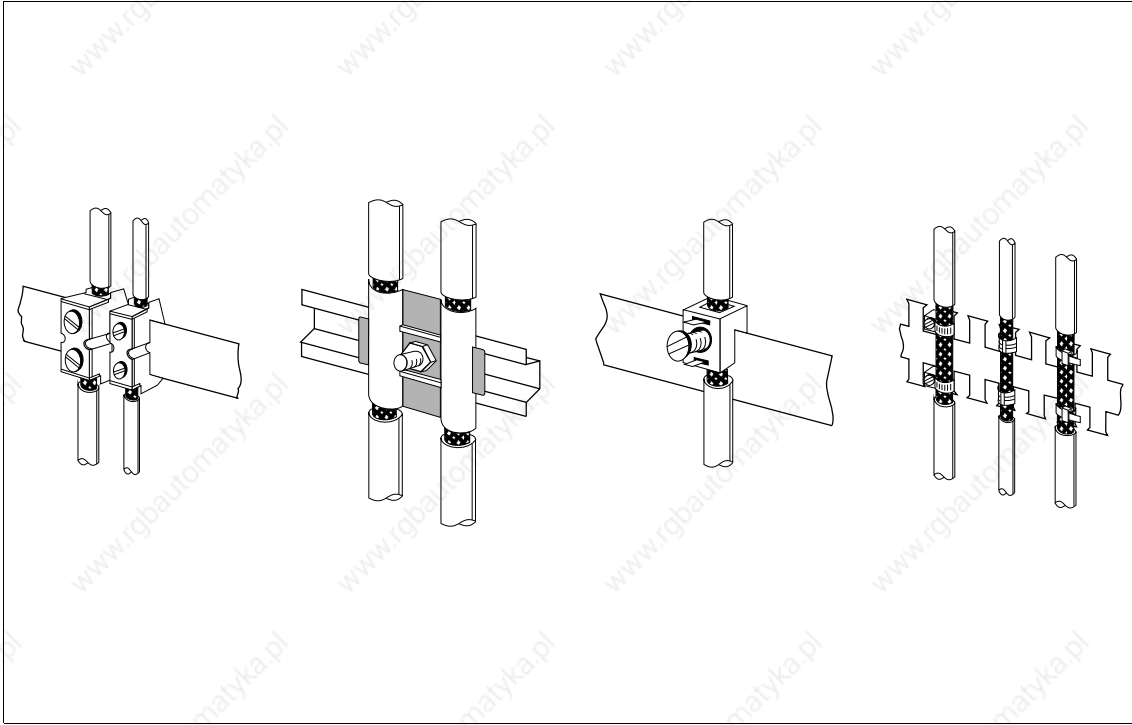

Figure 3-5 Examples of Securing Shielded Lines with Cable Clamps

### 3.3.4 Special Measures for Interference-Free Operation

#### *Fitting quenching elements to inductances*

As a rule, inductances such as contactor or relay coils controlled by SIMATIC S5 do not require external quenching elements in the circuit, because the quenching elements are already integrated in the modules.

Inductances should only be fitted with quenching elements

- when SIMATIC S5 output currents can be switched off by additionally fitted contacts, such as relay contacts. In this case the integrated quenching elements in the modules are no longer effective;
- if they are **not** controlled by SIMATIC S5 modules.

You can place freewheel diodes, varistors or RC networks in circuit with inductances.

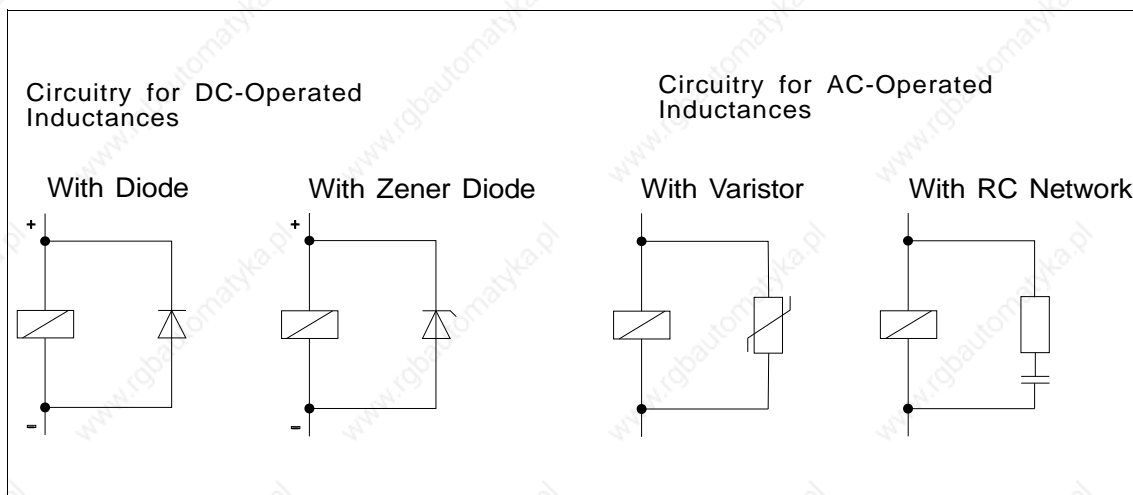

Figure 3-6 Quenching Circuits for Inductances

**AC power connection for programmers**

A power socket should be fitted in each cabinet for the AC supply to programmers. The sockets should be powered from the distribution system to which the protective conductor for the cabinet is also connected.

**Cabinet lighting**

Use incandescent bulbs, such as LINESTRA lamps, for cabinet lighting. Avoid using fluorescent lamps because they generate interference fields. If the use of fluorescent lamps cannot be avoided, apply the measures shown in the following figure.

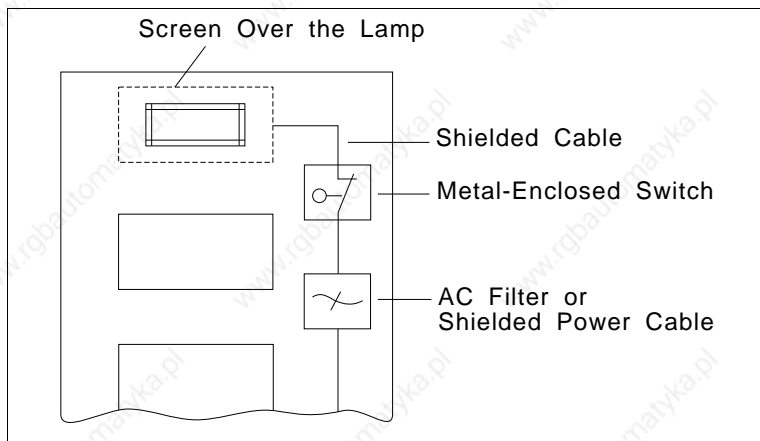

Figure 3-7 Measures for Interference Suppression of Fluorescent Lamps in a Cabinet

### 3.3.5 Checklist for the Electromagnetically Compatible Installation of Control Systems

EMC Measures	Notes
<b>Connection of inactive parts</b> (Section 3.2)	
Check, in particular, the connections on: <ul style="list-style-type: none"> <li>• Subracks</li> <li>• Cabinet members</li> <li>• Shield and protective conductor bars</li> </ul>	
Do all inactive metal parts have a large-area, low-impedance interconnection and ground?	
Is there a satisfactory connection to the ground/protective conductor system?	
Have insulating layers on painted and anodized surfaces been removed, or have special contact washers been used for the connections?	
Are connections protected from corrosion, e.g. by grease?	
Are cabinet doors connected to the cabinet element with grounding strips?	
<b>Routing of cables</b> (Section 3.3.1)	
Cabling subdivided into line groups?	
Supply cables (230 to 400 V) and signal lines laid in separate ducts or bundles?	
<b>Equipotential bonding</b> (Section 3.3.2)	
With a separate arrangement, check that the equipotential bonding conductor has been correctly laid.	
<b>Shielding of cables</b> (Section 3.3.3)	
Have metal connectors been used throughout?	
Are all analog and data lines shielded?	
Are line shields connected to the shield or protective conductor bar at the cabinet entry?	
Are line shields secured with cable clamps over a large area and at low impedance?	
Are line shields connected at both ends where possible?	
<b>Inductances</b> (Section 3.3.4)	
Are contactor coils which are switched via contacts, fitted with quenching elements?	



### 3.4 Power Supplies for Programmable Controllers and I/Os

This section describes:

- Which circuits you must distinguish in the control system and which demands are made on the power supply.
- Connection and grounding concept with higher-level infeed from grounded, centrally grounded and ungrounded supplies.
- Connecting the power supply to non-isolated and isolated modules.

#### 3.4.1

##### Power Supplies for Control Systems with SIMATIC S5

For control systems with SIMATIC S5, you will need:

- A power supply for the internal PLC circuits (control power supply)
- and a load power supply for the input and output circuits.

##### Power supply for the PLC circuits

The power supply for the internal PLC circuits powers the CPU and the modules used.

###### Note

Ensure that the control power supply is not overloaded. Make a current addition and estimate the current drawn by all modules.

##### Load power supply for the I/Os

The load power supply feeds the input and output circuits (load circuits) as well as sensors and actuators. Only a power supply which offers safe electrical isolation from the AC system may be used for the 24 V DC supply.



###### Caution

Only safety-separated low voltage DC  $\leq 60$  V may be used for the 24 V DC supply. The safety separation can be implemented according to the requirements of, amongst other sources, VDE 0100, Part 410/HD 384-4-41/IEC 364-4-41 (functional extra-low voltage with safety separation) or VDE 0805/EN 60950/IEC 950 (safety extra-low voltage SELV) or VDE 0106, Part 101.

##### Ratings of load power supplies

The electronic short-circuit protection of digital output modules only responds when 3-times the rated current is exceeded. You should therefore so design the load power supply units that the unit can supply the current required for shutting down in the event of a short-circuit at one output.

In the event of short-circuits at digital outputs, if the load power supply is not adequately rated, a current which is higher than the rated current can flow for a longer period without responding of the electronic short-circuit protection of the DQ module. Operation in the overload region can destroy the module.

*Load power supply for non-floating modules*

If you use non-floating modules, you must create a common reference potential for the internal control circuits of the PLC and for the load circuits. The reference potential of the load power supply should therefore be connected to the ground terminal of the PLC (PE or protective conductor terminal). The ground terminal is permanently connected to the internal reference potential of the controller.

3

*Load power supply for floating modules*

**Note**

If you use switched-mode power supply units for floating analog modules and BEROs, you must fit an AC system filter to the input of the power supply.

**3.4.2  
Connecting the  
Programmable Controller  
and Load Power Supply**

Each of the following figures shows a circuit example for connecting the control and load power supplies as well as the grounding concept for operation from:

- Grounded supplies
- Centrally grounded supplies
- Ungrounded supplies

When assembling the control system, observe the following explanations. The text contains identification numbers relating to Figures 3-8 to 3-10.

*Main switch and protection*

- For the programmable controller, sensors and actuators, you must fit a main switch ① to DIN VDE 0113, Part 1, or an isolating device to DIN VDE 0100, Part 460. If an AC plug is used as the isolating device, the socket must be in the vicinity of the CC and must be easily accessible (VDE 0805, 1.7.2). These devices are not required in the case of a subsystem where the appropriate devices are fitted at a higher level.
- The circuits for sensors and actuators can be given group protection for short-circuit and/or overload ②. According to VDE 0100, Part 725, single-phase protection is required; and all-phase protection to DIN VDE 0113, Part 1.

### Load power supply

- For 24 V DC load circuits, you require a load power supply unit ③ with safety separation. If an AC plug is used as the isolating device, the socket must be in the vicinity of the CC and easily accessible (VDE 0805, 1.7.2).
- Unregulated load power supply units require a reservoir capacitor ④ (rated at 200  $\mu$ F per 1 A load current). Connect the capacitor in parallel with the output terminals of the load power supply.
- According to DIN VDE 0113, Part 1, control systems with more than five items of electromagnetic apparatus require isolation by a transformer; according to DIN VDE 0100, Part 725, it is recommended ⑤.

### Grounding

- Load power supplies should be grounded if possible ⑥. Provide a detachable connection to the protective conductor at the load power supply unit (terminal L- or M) or on the secondary side of the isolating transformer.



#### Caution

For ungrounded power supplies, you must provide insulation monitoring if

- hazardous system states can be caused by double faults;
- there is no safety separation;
- circuits are operated with voltages of more than 120 V DC;
- circuits are operated with voltages of more than 50 V AC.

Operating a programmable controller with process I/Os from a grounded supply

Operation from grounded power supplies offers the best rejection of interference.

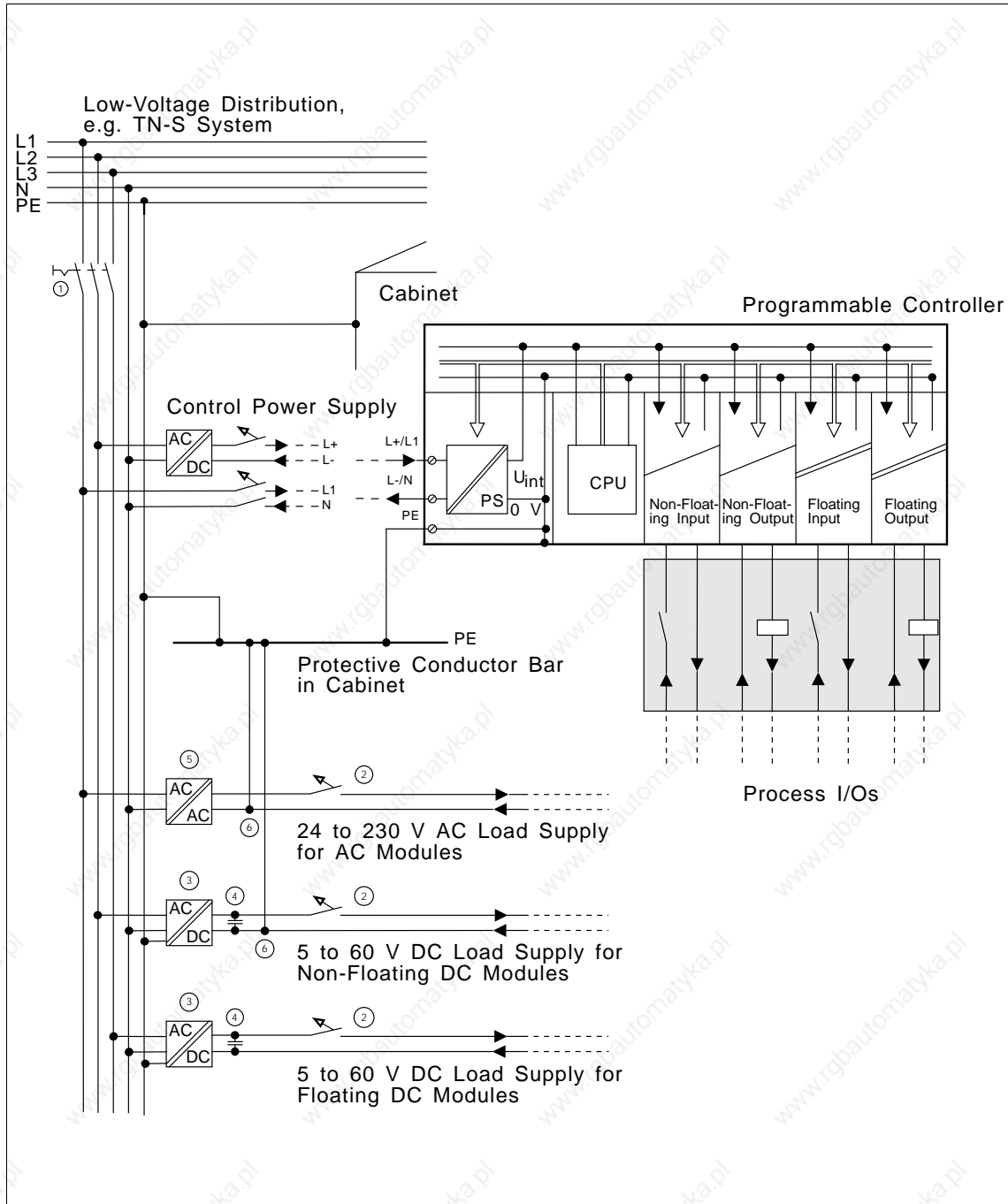

Figure 3-8 Operating a Programmable Controller with Process I/Os from a Grounded Supply

*Operating a programmable controller with process I/Os from a centrally grounded supply*

In systems with their own transformers or generators, the PLC is connected to the central ground. A detachable connection should be provided so that ground faults can be measured.

The PLC should be insulated from cabinet/protective conductor potential. To maintain this isolated arrangement, all connected devices must be operated with **capacitive grounding or ungrounded**. For this reason, programmers should only be powered via an isolating transformer.

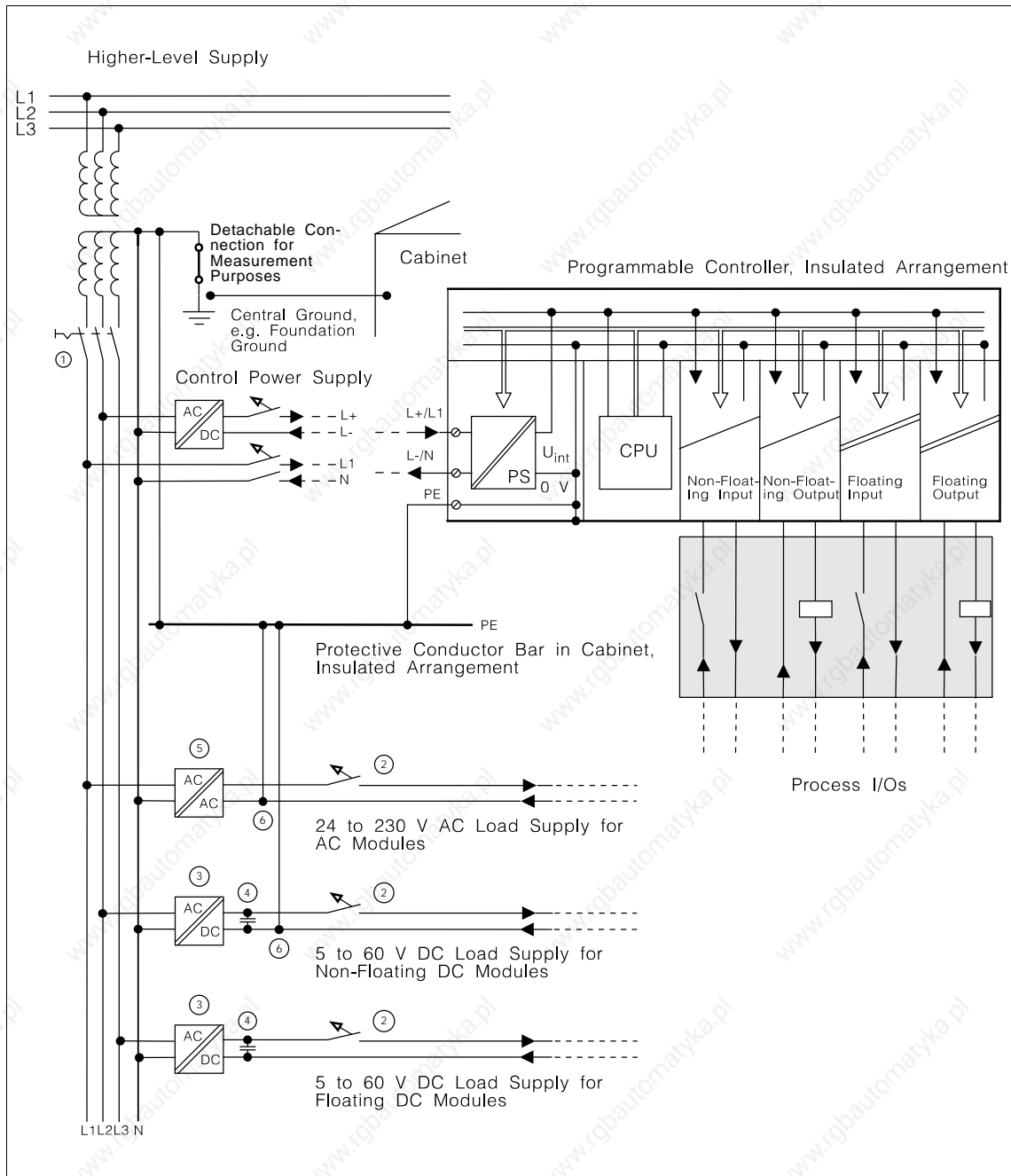

Figure 3-9 Operating a Programmable Controller with Process I/Os from a Centrally Grounded Supply

*Operating a programmable controller with process I/Os from an ungrounded supply*

In cases in which the higher-level power supply is not grounded, you must connect the programmable controller to a separate protective conductor/ground (e.g. foundation ground). Operation of the PLC with non-floating power supplies is **not** allowed.

When connecting the power supplies, please note:

In 3 x 230 V systems, you may connect the power supply directly to two phases.

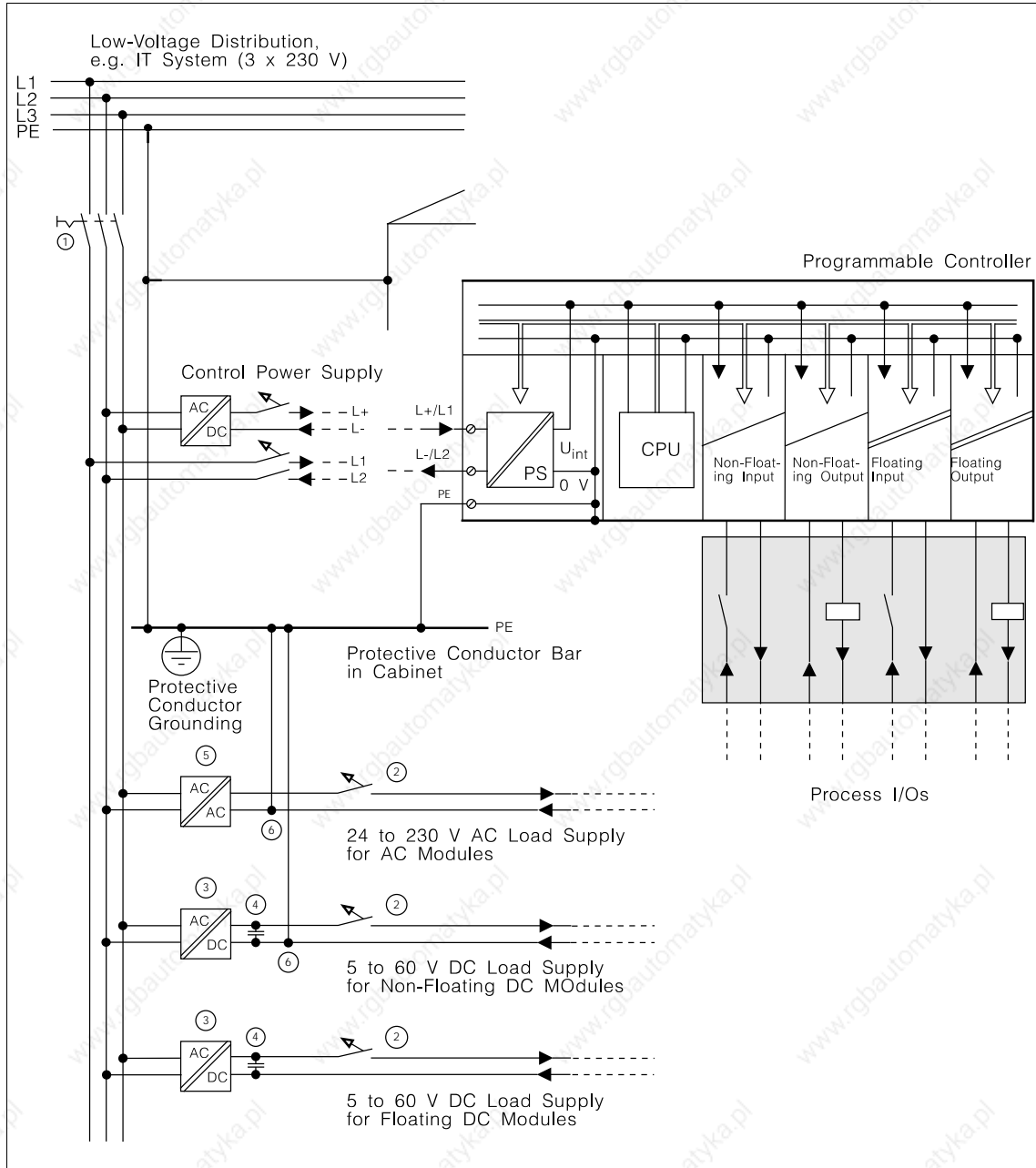

Figure 3-10 Operating a Programmable Controller with Process I/Os from an Ungrounded Supply

In 3 x 400 V systems, a connection between phase and neutral conductor is not allowed (excessively high voltage in the event of a ground fault). Intermediate transformers should be used in these systems.

**3.4.3 Connecting Non-Floating or Floating Modules**

Shown in the following sections are the special features when installing non-floating and floating modules.

**Installation with non-floating modules**

In an installation with non-floating modules, the reference potentials of the control circuit ( $0 V_{int}$ ) and load circuits ( $0 V_{ext}$ ) are electrically connected.

The reference potential of the control circuit ( $0 V_{int}$ ) is given by the PE or protective conductor terminal and must be connected to the reference potential of the load circuit via an externally laid conductor.

Shown in the following figure is a simplified installation with non-floating modules. The arrangement is independent of the grounding concept. The connections for grounding are therefore **not** drawn.

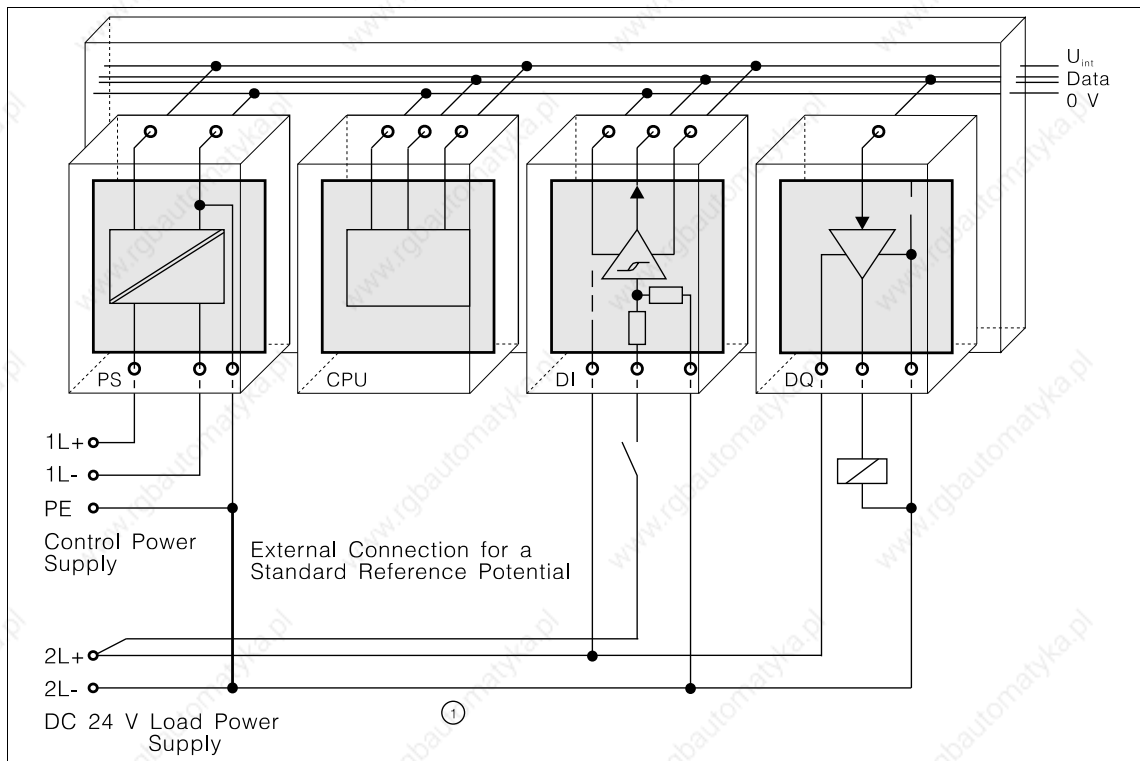

Figure 3-11 Simplified Representation of an Installation with Non-Floating Modules

The voltage drop on line ① must not exceed 1 V. Otherwise there will be a shift in reference potentials resulting in module malfunctions.

**Note**

For 24 V DC digital output modules with electronic short-circuit protection, you must ensure that the reference potential of the load power supply is connected to terminal L- of the module. If this connection is missing (e.g. open-circuit), a typical current of 15 mA can flow at the outputs. This output circuit is sufficient

- to prevent energized contactors or relays from being released,
- and to energize high-resistance loads (e.g. miniature relays).

**Installation with floating modules**

With floating modules the control circuit and load circuit are metallically isolated.

An arrangement with floating modules is required

- for all AC load circuits and
- for DC load circuits which cannot be coupled. The reasons are, for example, different reference potentials of the sensors or grounding of the positive terminal of a battery.

Shown in the following figure is a simplified installation with floating modules. The arrangement is independent of the grounding concept. The connections for grounding are therefore **not** drawn.

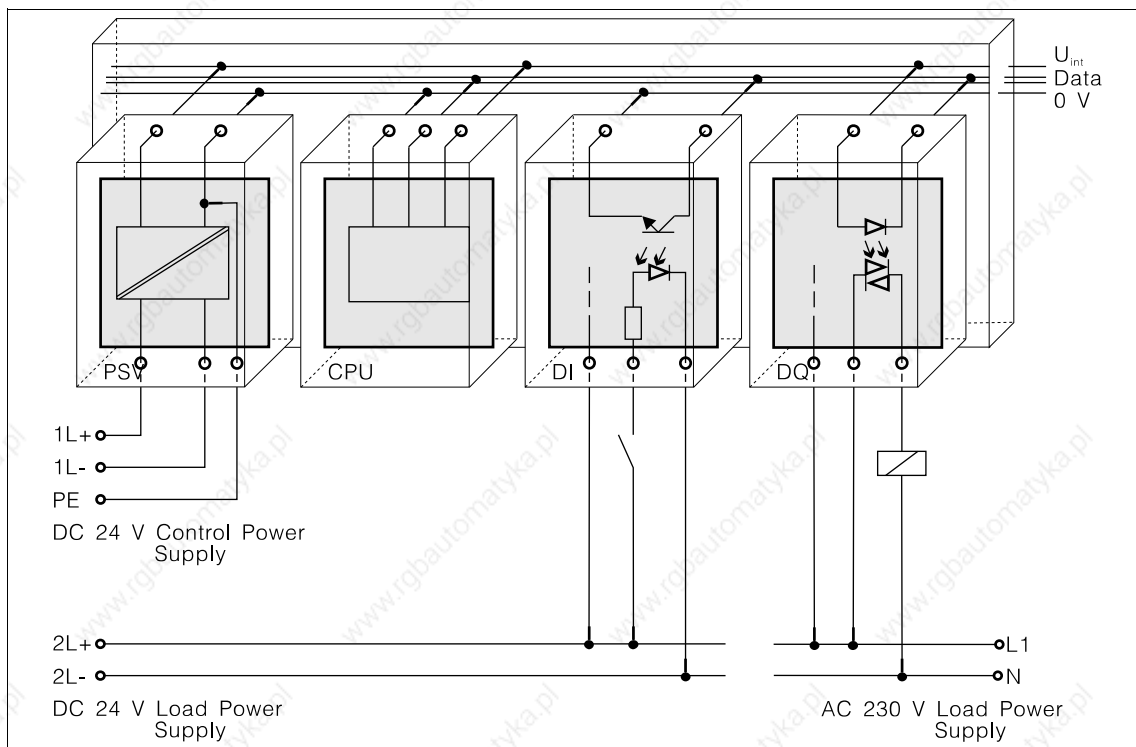

Figure 3-12 Simplified Representation of an Arrangement with Floating Modules



### 3.5 Interference-Free Installation of Centralized and Distributed Interface Circuits

Subjects described in the following sections are the shielding and grounding concept with centralized and distributed interface circuits.

Information on component selection, the mechanical arrangement and wiring can be found in the appropriate reference manuals for the interface modules.

#### Note

If you use components which are not approved for the installation of a centralized or distributed interface circuit, interference rejection may be impaired.

#### 3.5.1 Interference-Free Installation of Centralized Interface Circuits

When you connect the CC and EU centrally via suitable interface modules, no particular shielding and grounding measures are required. Ensure, however, that

- all subracks are interconnected at a low resistance;
- the subracks in a grounded arrangement have star-configuration grounding;
- the contact springs of the modules are clean and not bent, which could affect the path to ground for interference currents.

#### 3.5.2 Interference-Free Installation of Distributed Interface Circuits

If you interconnect the CC and EU in a distributed arrangement using suitable interface modules, no particular shielding and grounding measures are usually required. Only in industrial environments with an extremely high level of interference is there a need for special shielding and grounding.

In these cases, please observe the following points:

- Cable shields should be connected to the shield bar in the cabinet, immediately after the cable inlet;
  - insulation is fully stripped from the cable for the purpose;
  - braided shields are secured to the shield bar with as large an area as possible (e.g. with metal ties which enclose the shield over a large area).
- Shield bars should be connected to the frame or cabinet panel over a large area.
- Cable shields should be connected to the cabinet conductor.

With distributed interfacing (IM 304/IM 314 and IM 301/IM 310), ensure that the VDE specifications for laying the protective ground are complied with; distributed interfacing is non-floating.

The measures described above are shown in the following figure. If the permissible potential difference between ground points can be exceeded, you must install an equipotential bonding conductor (cross-section  $\geq 16 \text{ mm}^2$  of copper).

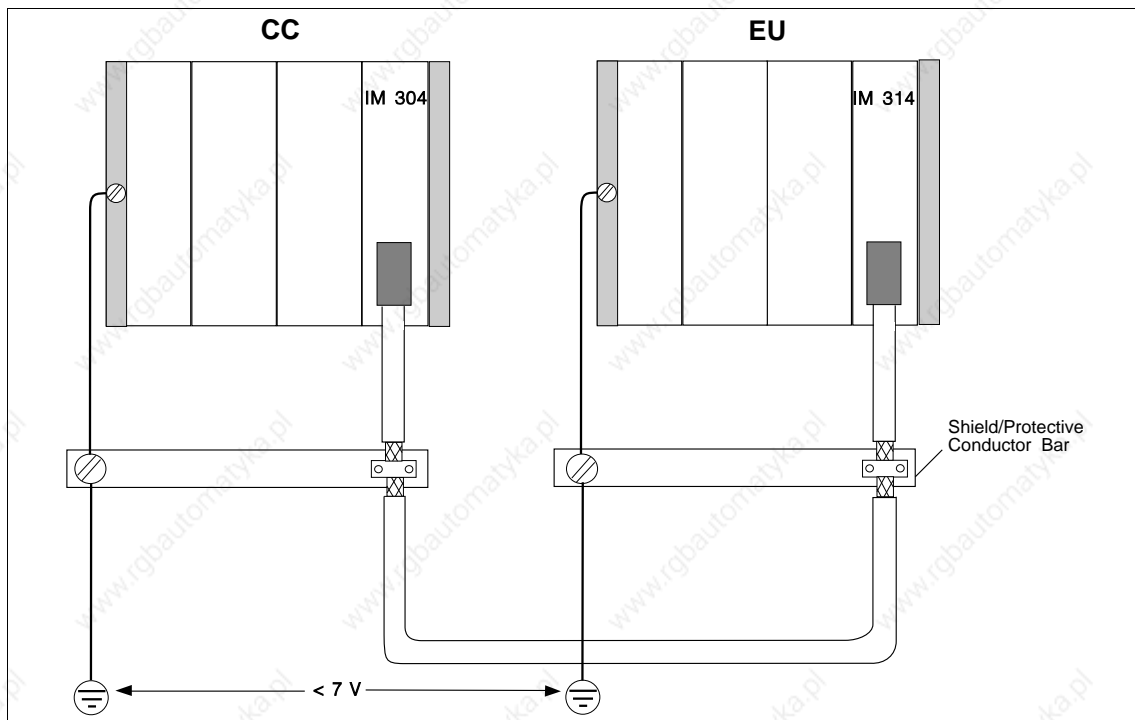

3

Figure 3-13 Shielding and Grounding the Connecting Cable

**Special features**

With distributed interfacing, you must use the prefabricated connecting cables. You may have excess lengths of up to 100 m when installing the connecting cable. These excess lengths must be bifilar-wound and deposited at a point which is protected from electromagnetic interference.

### 3.6 Interference-Free Connection of Monitors

These sections cover the following topics:

- Floating connection of cables at video inputs
- Shielding and grounding concept

Information on selecting the components can be found in Catalog ST80.

#### 3.6.1 Interference-Free Connection of a Monitor to the CP of the S5 Controller

Operator control and process monitoring systems from the COROS product family can be used with monitor connections. The physical arrangement of apparatus and the interference level of the environment are important for the interference-free connection of monitors to SIMATIC S5 control systems. The choice of monitor and video cables is governed by the following:

- Whether the monitor and PLC are to be operated under low-interference conditions  
or
- under industrial conditions.

##### *Operation of the monitor and PLC under low-interference conditions*

Where the monitor and PLC are installed under low-interference environmental conditions and operated over short distances, the monitor and PLC are at almost the same ground potentials. Interference and ground loop disturbances are therefore not expected.

In these cases, you can drive the monitor both via TTL signals and via analog signals. Digital cables or single-shielded coaxial cables can be used to transmit the video signals. Note that the braided shield of the coaxial cable serves as the return conductor and must **not** be connected to the shield bar. The monitor and communication processor (CP) are interconnected without additional shielding and grounding.

##### *Operation of the monitor and PLC under industrial conditions*

Where the monitor and PLC are installed under harsh industrial conditions and operated over great distances, the devices may be at different ground potentials. These different ground potentials may cause interference and ground loop disturbances.

In these cases, double-shielded coaxial cables (triaxial cables) must be used to transmit the video signals. The inner braided shield of the coaxial cable serves as the return conductor and must **not** be connected to the shield bar. The outer braided shield provides a path to ground for interference currents and must be incorporated in the shielding and grounding measures.

To avoid ground loops, the electronics ground and housing ground of the monitor must be independent. This requirement is met when:

- The electronics and housing grounds of the monitor are metallically isolated,
- or the electronics and housing grounds are connected via a voltage-dependent resistor (VDR) fitted by the manufacturer of the monitor.

3

### 3.6.2 Shielding and Grounding

If the monitor and PLC are used under harsh industrial conditions, you must ensure the following at the PLC end:

- Cables shields should be connected to the shield bar in the cabinet, immediately after the cable inlet;
  - the video cables should be fully stripped;
  - the outer braided shield should be secured to the shield bar of the PLC over as large an area as possible (e.g. with metal ties which enclose the shield or with cable clamps).
- Shield bars should be connected to the frame or cabinet panel over a large area.
- Shield bars should be connected to the ground point of the cabinet.

You must ensure the following at the monitor end:

- Separate the electronics ground and housing ground.
  - Remove the jumper at the monitor to separate the two grounds.
  - Fit touch protection at the video sockets because hazardous touch voltages of more than 40 V may be present at the sockets after separation of the grounds.
- Connect the ground clamp of the monitor to the protective conductor.
- Connect the cable shields to the ground clamp of the monitor;
  - fully strip the video cables;
  - secure the outer braided shield to the ground clamp of the monitor over a large area.

Shown in the following figure is a simplified representation of the shielding and grounding measures for installing the monitor and PLC.

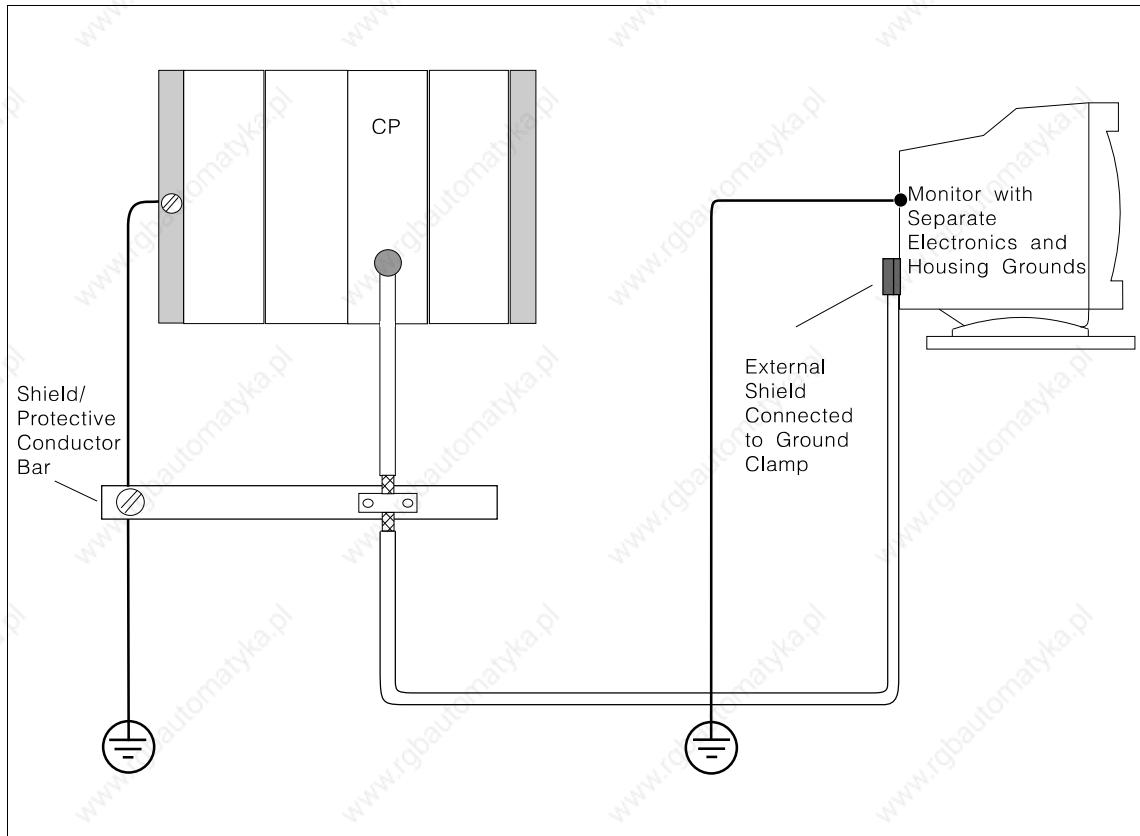

Figure 3-14 Shielding and Grounding for a Distributed Arrangement of Monitor and PLC

### 3.7 Selection and Installation of Cabinets with SIMATIC S5

The following criteria must be observed when selecting and dimensioning a cabinet:

- Ambient conditions at the point of installation of the cabinet
- Clearances for power supplies and subracks
- Total power dissipation of components in the cabinet

3

The ambient conditions at the point of installation of the cabinet (temperature, humidity, dust, effects of chemicals) govern the required degree of protection of the cabinet (IP XX) as shown in the following figure. Further information on types of protection can be found in IEC 529.

### 3.7.1 Types of Cabinet

The following table provides an overview of the most common types of cabinet. It also shows the principle of heat removal, as well as the estimated, maximum achievable power loss removal and the type of protection\*.

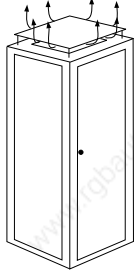
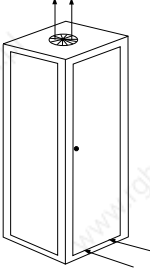
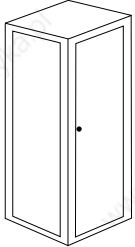
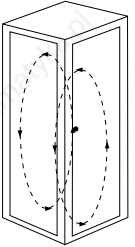
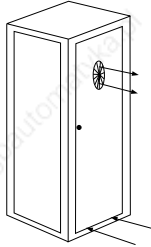
Open Cabinets		Closed Cabinets		
Through-ventilation by natural convection 	Increased through-ventilation 	Natural convection 	Forced circulation using fan assembly, enhanced natural convection 	Forced circulation using heat exchanger, external ventilation inside and outside 
Heat removal primarily by natural thermal convection, small portion via the cabinet wall	Increased heat removal through increased air movement	Heat removal only through the cabinet wall; only low power dissipation permissible. Heat accumulation usually occurs in the top of the cabinet.	Heat removal only via the cabinet wall. Forced ventilation of the internal air results in improved heat removal and prevention of heat accumulation.	Heat removal through exchange between heated internal air and cool outside air. The increased surface of the folded-area sectional wall of the heat exchanger and forced circulation of internal and external air permit good heat output.
Type of protection IP 20	Type of protection IP 20	Type of protection IP 54	Type of protection IP 54	Type of protection IP 54
Typical removable power dissipation under the following boundary conditions:				
<ul style="list-style-type: none"> <li>• Cabinet size 2200 x 600 x 600 mm</li> <li>• Temperature difference between external and internal temperature of the cabinet: 20 °C**</li> </ul>				
Up to 700 W	Up to 2700 W (1400 W with very fine filter)	Up to 260 W	Up to 360 W	Up to 1700 W

\* The location and ambient conditions are decisive for selection of the type of cabinet protection (see IEC 529 and DIN 40050).

\*\* For other temperature differences, refer to the temperature characteristics of the cabinet manufacturer.

### 3.7.2 Clearances in Cabinets

You must first define the components to be fitted in the cabinet. Then calculate the total power dissipation of the individual components. The following stipulations must be observed:

- The expansion units can be accommodated with the respective central controller in one cabinet, or in two or more cabinets (centralized or distributed).
- On account of the required clearances and maximum permissible installation height for control elements, a maximum of three SIMATIC S5 devices can be arranged one above the other.

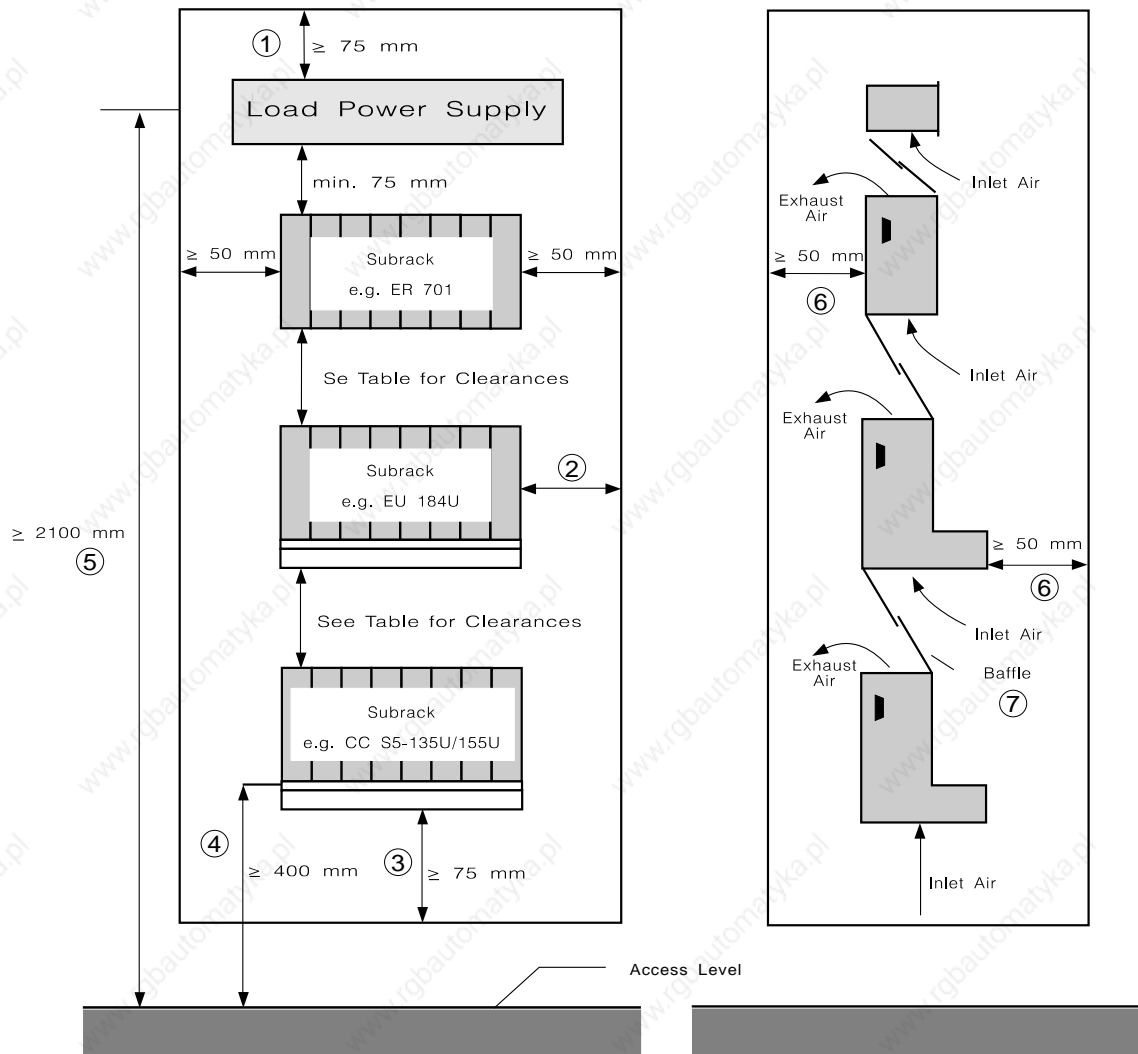

3

- ① 75 mm min.. Smaller clearances are possible with a closed cabinet roof and an additional, separate ventilation roof.
- ② A maximum clearance of 400 mm is possible (50 mm min.) when devices are connected next to one another.
- ③ 75 mm min. from obstructions (large apparatus) in the air inlet area.
- ④ 400 mm minimum installation height above access level for control elements, 200 mm for connections.
- ⑤ Maximum installation height for control elements: 2100 mm to DIN VDE 0106, Part 100, 2000 mm to DIN VDE 0113.
- ⑥ Space for air circulation (400 mm deep cabinets are sufficient).
- ⑦ Baffles are recommended to improve the air supply.

Figure 3-15 Clearances in the Cabinet



Where subracks (CC and EU) are arranged one above the other, the installation clearances in the following table must be observed.

Upper Subrack	Lower Subrack	Min. Clearances	Max. Clearances
S5-135U/155U or S5-115U or S5-90U/95U/100U	S5-135U	75 mm 87 mm if baffle is used	The maximum clearance is limited by the lengths of connecting cables for the interface modules.
	S5-115U with fan	60 mm	
	S5-115U without fan	100 mm	
	S5-90U/95U/100U	75 mm	

The following two points should be observed to improve the air circulation within the cabinet:

- The expansion unit with the greatest power dissipation to be removed should be the upper unit.
- If subracks of the S5-135U/155U series are installed together with subracks of the S5-90U to 115U series in one cabinet, the rear panels of all subracks must be at the same distance from the rear wall of the cabinet.

**3.7.3  
Removal of Power  
Dissipation from Cabinets**

The power dissipation that can be removed from a cabinet is governed by the cabinet design, its ambient temperature and the arrangement of equipment in the cabinet.

Shown in the following figure is a diagram with guide values for the permissible ambient temperature of a cabinet measuring 600 x 600 x 2200 mm, as a function of power dissipation. These values only apply to the arrangement of equipment in the cabinet as given in Section 3.6.2. Further details can be found in Catalogs NV21 and ET1.

**3**

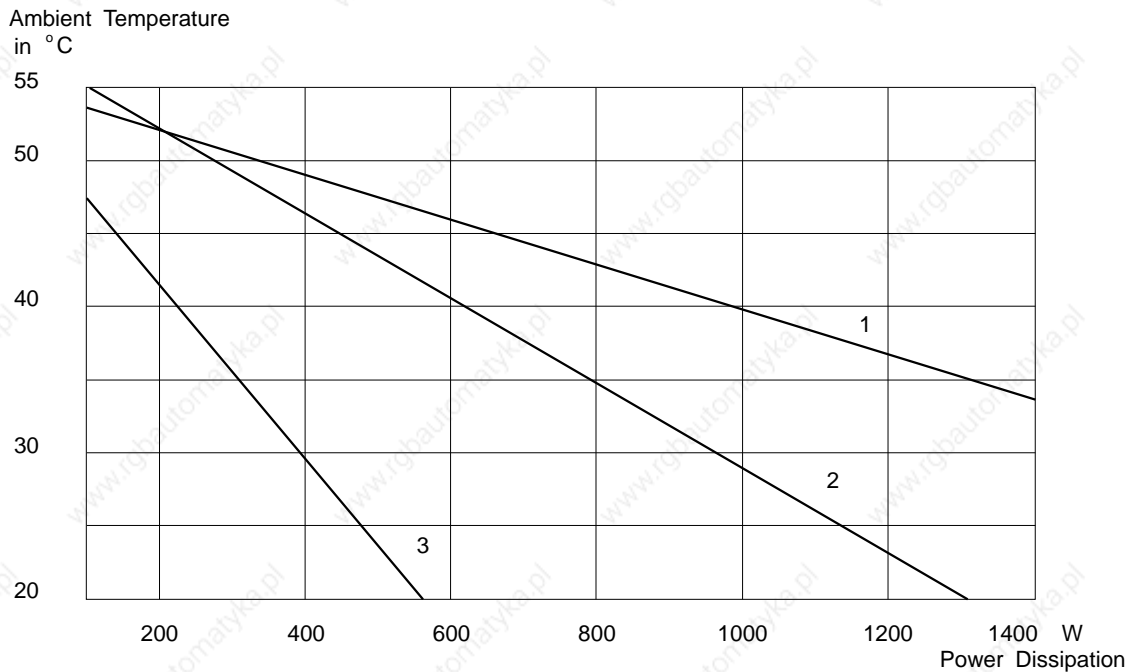

- 1 Closed cabinet with heat exchanger of size 11/6 (920 x 460 x 111 mm)
- 2 Cabinet with through ventilation by natural convection
- 3 Closed cabinet with natural convection and forced circulation using fan

Figure 3-16 Maximum Cabinet Ambient Temperature as a Function of Power Dissipation

**Note**

When fitting the subracks of the S5-135U/155U series, the maximum power dissipation which can be removed by the fans must not be exceeded. The maximum removable power dissipation per unit with a supply air temperature of 55 °C is 250 W. This value is increased by 20 W for each reduction in supply air temperature by 1 °C.



**Caution**

Modules with a hard disk drive can only be used at an ambient temperature of up to 50 °C.

**3.7.4  
Examples for Determining  
the Type of Cabinet**

The following example shows the maximum permissible ambient temperature with various cabinet types and the same power dissipation.

**Example**

The following equipment configuration is given:

1	Central controller	200 W
2	Expansion units, 250 W power dissipation each	500 W
1	Load PS, 24 V/40 A, 6EV1 362-5BK00 (full load)	200 W
Total power dissipation		900 W

From Figure 3-16, with a total power dissipation of 900 W, the maximum ambient temperatures given by the table are as follows:

<b>Cabinet Design</b>	<b>Max. Permissible Ambient Temperature</b>
Closed, with natural convection and forced circulation (Curve 3)	(Operation not possible)
Open with through-ventilation (Curve 2)	Approx. 33 °C
Closed, with heat exchanger (Curve 1)	Approx. 42 °C

**3.7.5  
Determining the Power  
Dissipation of Modules**

The power dissipation of the modules can be found in the technical specifications of the catalogs or manuals. If these values are not yet incorporated in the technical specifications, they can be easily calculated from the current consumption. The value of current consumption must be multiplied by the corresponding voltage value.

**Examples**

CPU 928B	Current consumption	5A/5V	→ Power dissipation = 25 W
CP 143	Current consumption	4A/5V 0.5A/15V 0.04A/24V	→ Power dissipation approx. 21 W
IM 304	Current consumption	1.5A/5V	→ Power dissipation = 7.5 W

# 4

## Central Controllers and Expansion Units, Power Supply Units

### Contents of Chapter 4

4	Central Controllers and Expansion Units, Power Supply Units.....	4 - 3
4.1	S5-135U/155U Central Controller .....	4 - 4
4.1.1	Technical Description .....	4 - 4
4.1.2	Installation.....	4 - 8
4.1.3	Startup .....	4 - 12
4.1.4	Repair Guidelines .....	4 - 14
4.1.5	Technical Specifications .....	4 - 15
4.2	Expansion Units .....	4 - 17
4.2.1	Technical Description of the Expansion Units.....	4 - 18
4.2.2	Installing the Expansion Units .....	4 - 20
4.2.3	Technical Specifications of the Expansion Units.....	4 - 20
4.3	Power Supply Units .....	4 - 21
4.3.1	Product Overview .....	4 - 21
	Power supply types .....	4 - 21
	Basic functions .....	4 - 22
	Monitoring functions .....	4 - 22
	Signalling functions .....	4 - 23
	Inputs and outputs .....	4 - 24
	Indicators and controls .....	4 - 25
4.3.2	Setting and Connecting the Power Supply Unit.....	4 - 26
	Brief instructions for startup .....	4 - 27
	Establishing the setting and cabling .....	4 - 28
	Removing the power supply unit .....	4 - 31
	Setting the jumpers .....	4 - 32
	Fitting the power supply unit.....	4 - 33
	Wiring the power supply unit .....	4 - 33
	Fitting the lithium battery .....	4 - 34
	Removing the right-hand fan and connecting the rechargeable battery .....	4 - 36

	Fitting the filter subdrawer . . . . .	4 - 37
	Setting the voltage selector switch . . . . .	4 - 37
	Switching on the power supply unit for the first time. . . . .	4 - 38
4.3.3	Fault Indications/Fault Diagnostics . . . . .	4 - 39
4.3.4	Maintenance and Repairs . . . . .	4 - 43
	Replacing the lithium battery . . . . .	4 - 44
	Replacing a fan . . . . .	4 - 45
	Replacing the rechargeable battery . . . . .	4 - 47
	Replacing the filter mat . . . . .	4 - 49
	Replacing a power supply unit . . . . .	4 - 50
4.3.5	Description of Internal Sequences in the Power Supply Unit . . . . .	4 - 52
	Behavior upon failure of the system supply . . . . .	4 - 52
	Behavior upon failure of fans . . . . .	4 - 53
4.3.6	Technical Specifications of the Power Supply Units . . . . .	4 - 54
4.4	24 V/4 A Load Power Supply . . . . .	4 - 61
4.4.1	Technical Description . . . . .	4 - 61
	Application . . . . .	4 - 61
	Design . . . . .	4 - 61
	Outputs. . . . .	4 - 62
	Inputs . . . . .	4 - 63
	Indicators . . . . .	4 - 63
	Controls . . . . .	4 - 63
	Front connector . . . . .	4 - 63
4.4.2	Startup . . . . .	4 - 65
	Setting the AC voltage. . . . .	4 - 65
	Connecting the AC leads . . . . .	4 - 65
4.4.3	Fault Indications/Fault Diagnostics . . . . .	4 - 66
4.4.4	Technical Specifications . . . . .	4 - 67
4.5	6ES5 955-3NA12 Power Supply Unit . . . . .	4 - 69
4.5.1	Technical Description . . . . .	4 - 69
	Indicators and controls . . . . .	4 - 70
	Terminals . . . . .	4 - 71
	15 V auxiliary submodule . . . . .	4 - 71
4.5.2	Setting the Power Supply Unit . . . . .	4 - 72
	Locations of jumpers . . . . .	4 - 72
	Functions of the jumpers . . . . .	4 - 72
	Setting the fan monitor . . . . .	4 - 73
	Setting the backup battery monitor . . . . .	4 - 74
4.5.3	Installation. . . . .	4 - 75
	Installing the 15 V auxiliary submodule. . . . .	4 - 75
4.5.4	Operation. . . . .	4 - 76
	General notes on the power supply unit . . . . .	4 - 76
	Fault indications/ diagnostics . . . . .	4 - 77
4.5.5	Maintenance . . . . .	4 - 78
	Replacing the backup battery . . . . .	4 - 78
	Replacing the fans . . . . .	4 - 79
4.5.6	Technical Specifications . . . . .	4 - 80

# Central Controllers and Expansion Units, Power Supply Units

# 4

# 4

The S5-135U/155U programmable controller comprises a central controller (CC) and, depending on the configuration, one or more expansion units (EUs). Expansion units are connected when there are insufficient central controller slots, or when you wish to position I/O modules as closely to the process as possible (see also Chapter 2).

With the central controllers and some expansion units, the modules are directly powered and cooled via the integrated power supply plug-in module. With all other expansion units, power is supplied via the IMs from the CC (see also Chapter 7).

## 4.1 S5-135U/155U Central Controller

This description applies to the S5-135U/155U CC with the following power supply units.

Order No. of the CC	With Power Supply Unit	Input Voltage
6ES5 188-3UA11	6ES5 955-3LC41	120 V/230 V AC, 18 A
6ES5 188-3UA21	6ES5 955-3LF41	120 V/230 V AC, 40 A
6ES5 188-3UA31	6ES5 955-3NC41	24 V DC, 18 A
6ES5 188-3UA51	6ES5 955-3NF41	24 V DC, 40 A
6ES5 135-3UA41	6ES5 955-3NA12	24 V DC, 10 A

### 4.1.1 Technical Description

The S5-135U/155U CC consists of a housing with backplane bus to accept the individual modules, and a power supply unit with fans to power and cool the modules.

*A central controller assembly*

Shown in the following figure are the most important parts of a central controller.

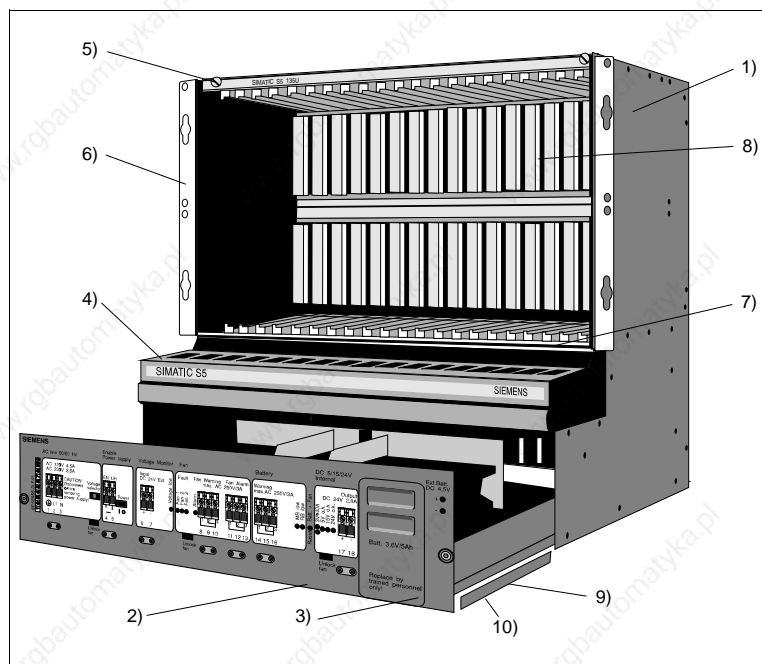

Figure 4-1 A Central Controller Assembly

- 1) Housing with 21 slots for modules
- 2) Power supply unit with fans
- 3) Battery compartment
- 4) Cable duct
- 5) Locking bar
- 6) Mounting bracket
- 7) Sectional rail for individually locking the modules
- 8) Backplane bus
- 9) Filter subdrawer (optional)
- 10) Rechargeable battery



**Housing**

The housing consists of bolted sheet-steel sections with ventilation openings at the top and bottom. The housing contains the bus PCB for electrical and logical interconnection of the modules. All the slots have guiderails which accept the modules. Male and female connectors are thus precisely positioned. There is a locking bar at the top of the housing to prevent the modules from becoming accidentally detached. Modules with individual locking are secured in the lower sectional rail. There is a cable duct for incoming and outgoing cables at the front of the housing.

**Power supply unit**

The power supply unit with the fans is situated in the lower part of the central controller frame. Depending on the type of power supply, the input voltage is either 24 V DC or 230/120 V AC. The AC version can be adjusted to the required AC voltage with a selector switch.

**Modules and slot assignments in the S5-135U/155U CC**

The following table shows which modules can be inserted at which slots.

Slot No.	3	11	19	27	35	43	51	59	67	75	83	91	99	107	115	123	131	139	147	155	163	
<b>Module Type</b>																						
923 coordinator	■																					
CPU 922		■		■		■		■														
CPU 928, CPU 928B CPU 948		■	■	■	■	■	■	■	■	■												
CP 5XX, CP 143, CP 5430, CP 5431 <sup>1)</sup>			■	■	■	■	■	■	■	■	■	■	■	■	■	■	■	■	■			
IM 300-5 IM 301-5 <sup>2)</sup>																					■	■
IM 300-3, IM 301-3 IM 304, IM 308, IM 308B IM 307 <sup>1) 3)</sup>														■	■	■	■	■	■	■	■	■
DI, DQ AI, AQ <sup>1)</sup>	■		■	■	■	■	■	■	■	■	■	■	■	■	■	■	■	■	■	■	■	■
IP 241USW, IP 244, IP 246, IP 247, IP 252 <sup>1)</sup>			■	■	■	■	■	■	■	■	■	■	■	■	■	■	■	■	■			
IP 240, IP 241, IP 242, IP 242A, IP 242B, IP 243, IP 281 <sup>1) 4) 5)</sup>			■	■	■	■	■	■	■	■	■	■	■	■	■	■	■	■	■			
IP 245 IP 257 <sup>6)</sup>			■	■	■	■	■	■	■	■	■	■	■	■	■	■	■	■	■	■	■	■
IP 260, IP 261			■	■	■	■	■	■	■	■	■	■	■	■	■	■	■	■	■	■	■	■
Load power supply -951 <sup>1)</sup>			■	■	■	■	■	■	■	■	■	■	■	■	■	■	■	■	■	■	■	■

■ Electrical connection      □ Mechanical width

- 1) Allow for particular module widths; additional slots to the right may be occupied (see Catalog ST 54.1).
- 2) In the CC with Order No. 6ES5 135-3UA41, only at Slot 163
- 3) Observe jumper setting on the IM 307; interrupt transmission is only possible at Slots 107 to 131.
- 4) Operation at Slots 27, 43, 59, 139, 147 is only possible with severely restricted functions, because no interrupts are wired.
- 5) IP 243 without D/A or A/D converter can be used at Slots 27, 43, 59, 139 and 147.
- 6) Allow 1 to 4 slots for the DI/DQ 482 to the right of the IP 257.



**Caution**

Do not insert modules at slots which are not intended for them, otherwise these or other modules may be destroyed.

The following table shows which slots have particular characteristics. The manuals for the individual modules explain how these characteristics can be utilized.

Slot No.	3	11	19	27	35	43	51	59	67	75	83	91	99	107	115	123	131	139	147	155	163	
Characteristic																						
PG MUX possible <sup>1)</sup>		0		1		2		3		4	5	6	7									
Interrupt source (process interrupt)																						
Battery backup 24 V supply 15 V supply																						

<sup>1)</sup> The numbers indicate the station numbers for programmer (PG) communication via PG multiplexers of the COR 923C.

The modular packaging technique allows variable configuration of a CC with modules and its adaptation to the particular automation task.

The various modules carry out the following tasks:

- CPU  
The CPU processes the input signals of the PLC according to the user program, and emits the results as output signals. The following CPUs can be used in the S5-135U/155U PLC
  - CPU 948
  - CPU 928B
  - CPU 928
  - CPU 922
- Coordinators  
By using a coordinator, you can configure the S5-135U/155U as a multiprocessor controller with up to four task-oriented CPUs in different combinations. Each CPU processes its program independently of the others.
- I/O modules  
The I/O modules provide the link to the process.
- IP module  
The intelligent I/O modules (signal pre-processing modules) off-load the CPU by independently executing compute-intensive tasks such as controlling, counting and positioning.

- **Interface modules (IMs)**  
If your CC has insufficient slots to insert all the modules required for your automation task, you can increase the number of modules with expansion units. The IM modules provide the link between central controller and expansion units.
- **CP module**  
CP modules allow point-to-point communication for data interchange between two PLCs, between one PLC and an external unit, between one PLC and a SINEC bus system or between one PLC and the COROS operator control and process monitoring system. You can use additional CP modules, such as the CP 581, CP 516, for the acquisition, storage, administration and preprocessing of large volumes of data.
- **VP module**  
VP modules enable the local acquisition and displaying (visualization) of process data of a PLC of the SIMATIC S5.

#### 4.1.2 Installation

*Installing the central controller* The S5-135U/155U CC is designed for installation in cabinets, on racks and walls. The S5-135/155U CC must only be accessible from the front for connection and maintenance work.

Consult the Installation Guidelines in Chapter 3 for planning and implementing the installation with respect to EMC.

Shown in the following figures are the important dimensions in mm for installation of a CC.

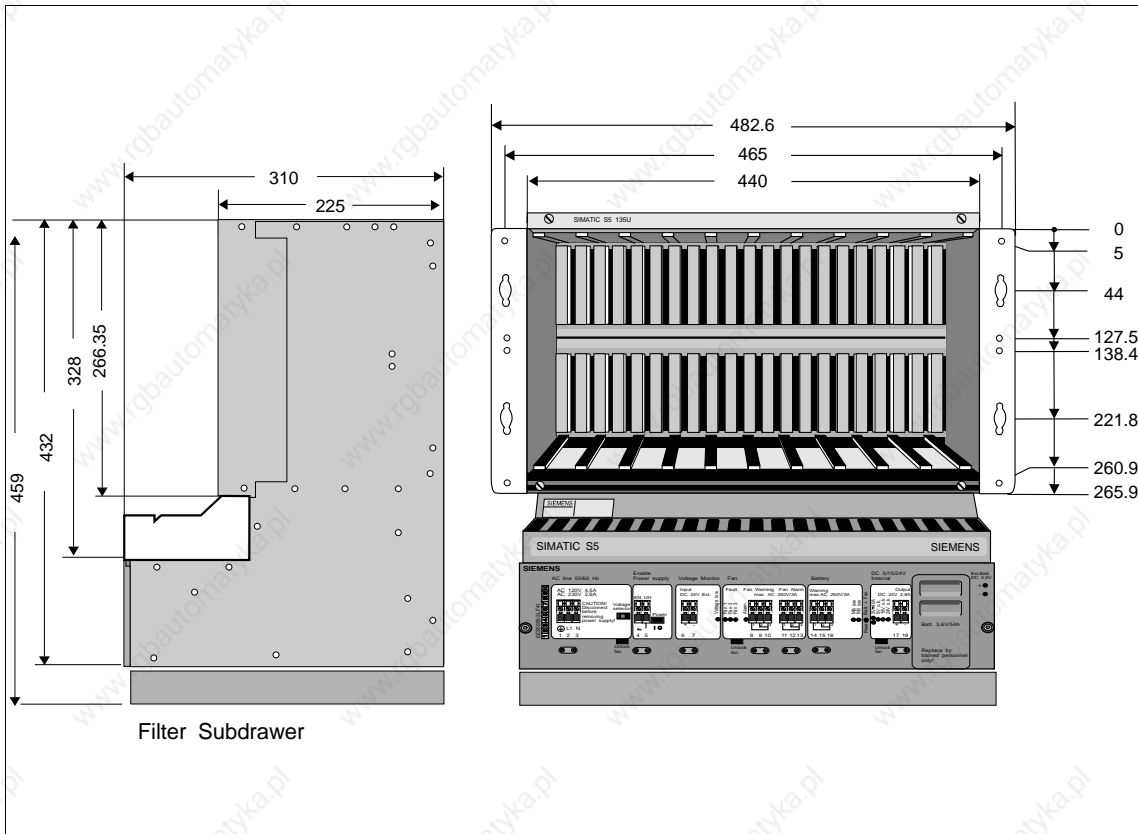
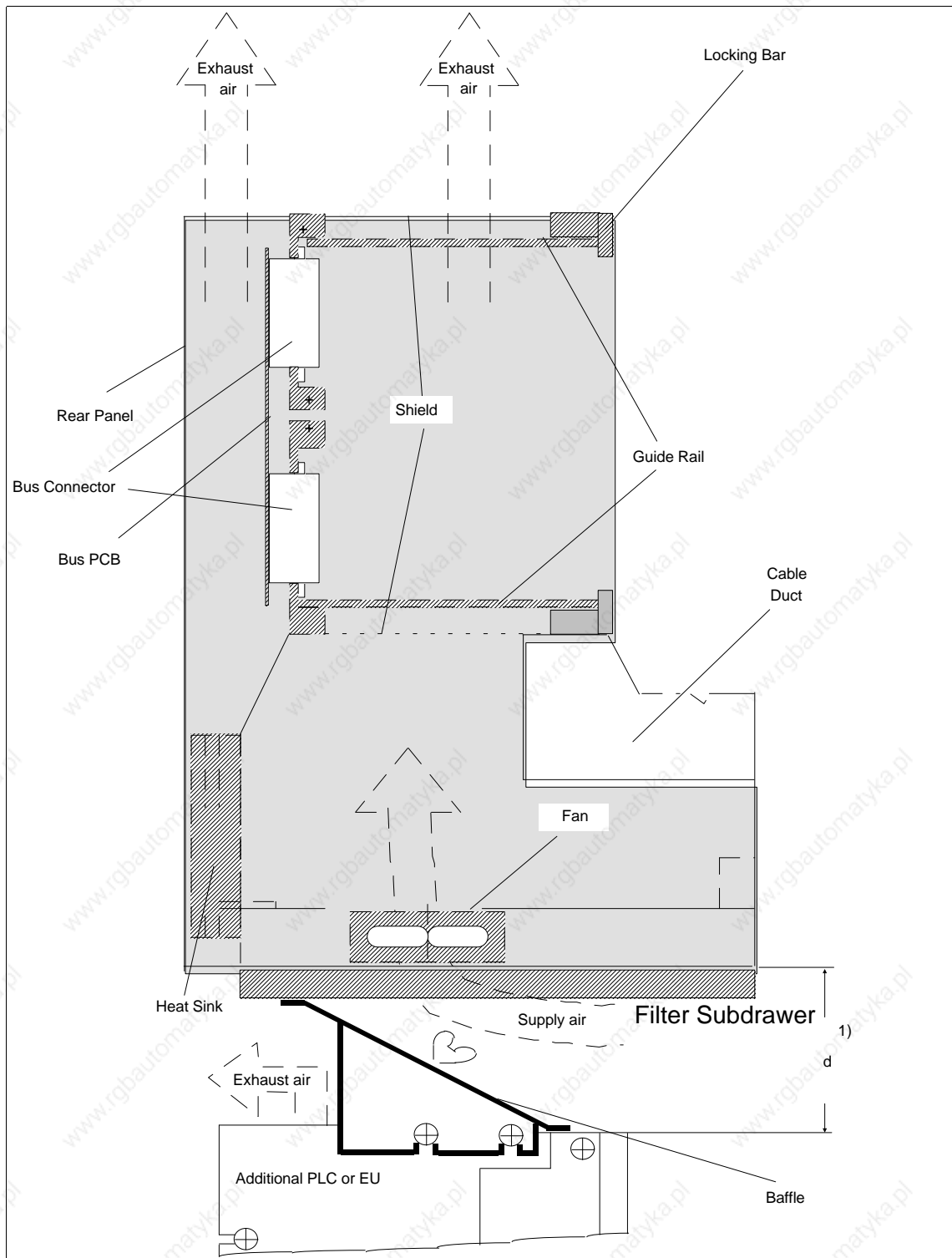

Figure 4-2 Mounting Dimensions of an S5-135U/155U Central Controller

An air supply as shown in the following illustration must be ensured.



4

Figure 4-3 Air Supply to the Central Controller

- 1) d: Clearance > 87 mm when a baffle is used
- d: Clearance > 89 mm when a filter subdrawer is fitted
- d: Clearance > 75 mm without filter subdrawer

You can use the mounting brackets on the subrack for installation in cabinets, on racks and walls. Use M6 bolts or, for wall mounting, screws of suitable size.

One person can carry out the installation work.

The mounting brackets can be fitted to the housing in the following ways:

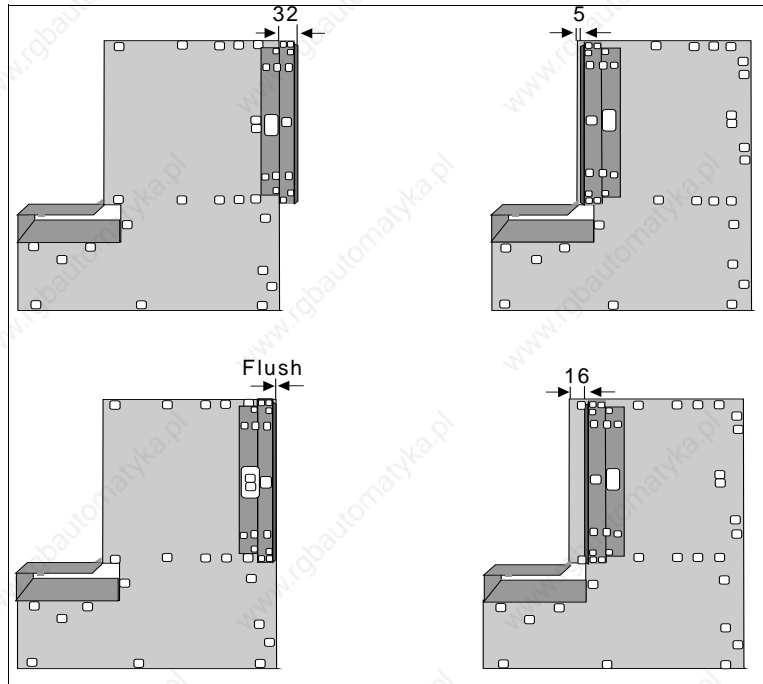

Figure 4-4 Methods of Fitting the Mounting Brackets

### Fitting the modules

The dimensions of the modules for the S5-135U/155U PLC comply with the double-height Eurocard format (h x d = 233.4 x 160 mm).

There are modules with different mounting width. For example:

Slots Occupied	SPS <sup>1)</sup>	Front Plate Width in mm	Example
1	1 <sup>1</sup> / <sub>3</sub>	20.3	CPU 922
2	2 <sup>2</sup> / <sub>3</sub>	40.6	CPU 948
4	5 <sup>1</sup> / <sub>3</sub>	81.3	CP 580

<sup>1)</sup> SPS standard plug-in station: 1 SPS = 15.24 mm

Proceed as follows to fit the modules:

Step	Action
1	Disconnect the CC from system power.
2	Slacken the two screws with which the locking bar is fixed to the subrack.
3	Pull the locking bar forward to its end stop. – The rail swivels up.
4	If there is a locking pin on the lower part of the module, turn it to the horizontal position.
5	Grasp the module at the front plate, insert it into the lower and upper guide rails and push it in. – The connectors at the rear will engage in the sockets on the backplane bus, and the release lever on the lower part of the module will be horizontal.
6	If a locking pin is fitted, push it in and rotate it 90 degrees. – If you have correctly fitted the module so far, it should no longer be possible to pull it out of the subrack.
7	Swivel the locking bar down and push it back into the subrack.
8	Retighten the two screws on the locking bar.

4

Some I/O modules can also be fitted or removed during operation. Consult the reference manuals for the I/O modules, under "Release circuit".

Free slots can be covered with dummy front plates. This improves the flow of cooling air in the unit. See the ordering information for order numbers.

#### Connection of CPUs, CPs and IMs

The connecting cables of CPUs, communication processors and EU interface modules are connected with metal front connectors.

There are two types of metal front connector:

A metal front connector with slide lock is secured after plugging it in, by sliding the lock downward.

A metal front connector with milled screws is secured to the unit with the screws.

#### Note

Ensure that the connectors are assigned to the correct modules to avoid damage.

The connection of signal lines for the I/O modules is described in Chapters 8 and 9.

### 4.1.3 Startup

Place the CC in operation in the sequence of steps given here. This will take you up to the first trial run of the CPU. Given in parentheses are references to the chapters of the manual in which the subject is explained in detail.

To ensure a straightforward sequence for the startup, commence with one CPU and no EUs.

Proceed according to the following steps to place the CC in operation:

Step	Action
1	Install the PLC so that the supply of air and exhaust air are unimpeded. If you fit two or more units (CC and EU) in one cabinet, observe the clearances and use baffles where necessary (see Chapter 3).
2	Fit the lithium battery (see Sections 4.3 and 4.5) and connect the rechargeable battery.
3	Fit the CPU and set the mode switch to STOP.
4	Connect the power supply and, with a 230/120 V AC supply, the 24 V DC load supply, to the monitoring input. Check the setting of the voltage selector switch (on 230/120 V AC power supplies). Fit a protective cover over the AC terminals.
5	Switch on the power and, if present, the 24 V. <b>Reaction:</b> Green LED "Power Supply ok" in the "DC 5 V" field and in the "DC 15/24 V" field, as well as yellow LEDs "RB low" and "MB low" light up.
6	Hold the CPU switch in the OVERALL reset position and set the switch from STOP to RUN. <b>Reaction:</b> The "Stop" LED flashes rapidly.
7	Repeat Step 6. <b>Reaction:</b> The "Stop" LED lights up constantly.
8	Keep the pushbutton in the RESET position and set the switch from STOP to RUN. <b>Reaction:</b> Green "Run" LED lights up, "BASP" LED (output inhibit) goes off.



Startup and validity check

The following flowchart provides an overview of the sequence for startup and validity check of a CC with CPU inserted and with no user program. For the CPU 948, all steps relating to the memory submodule are skipped.

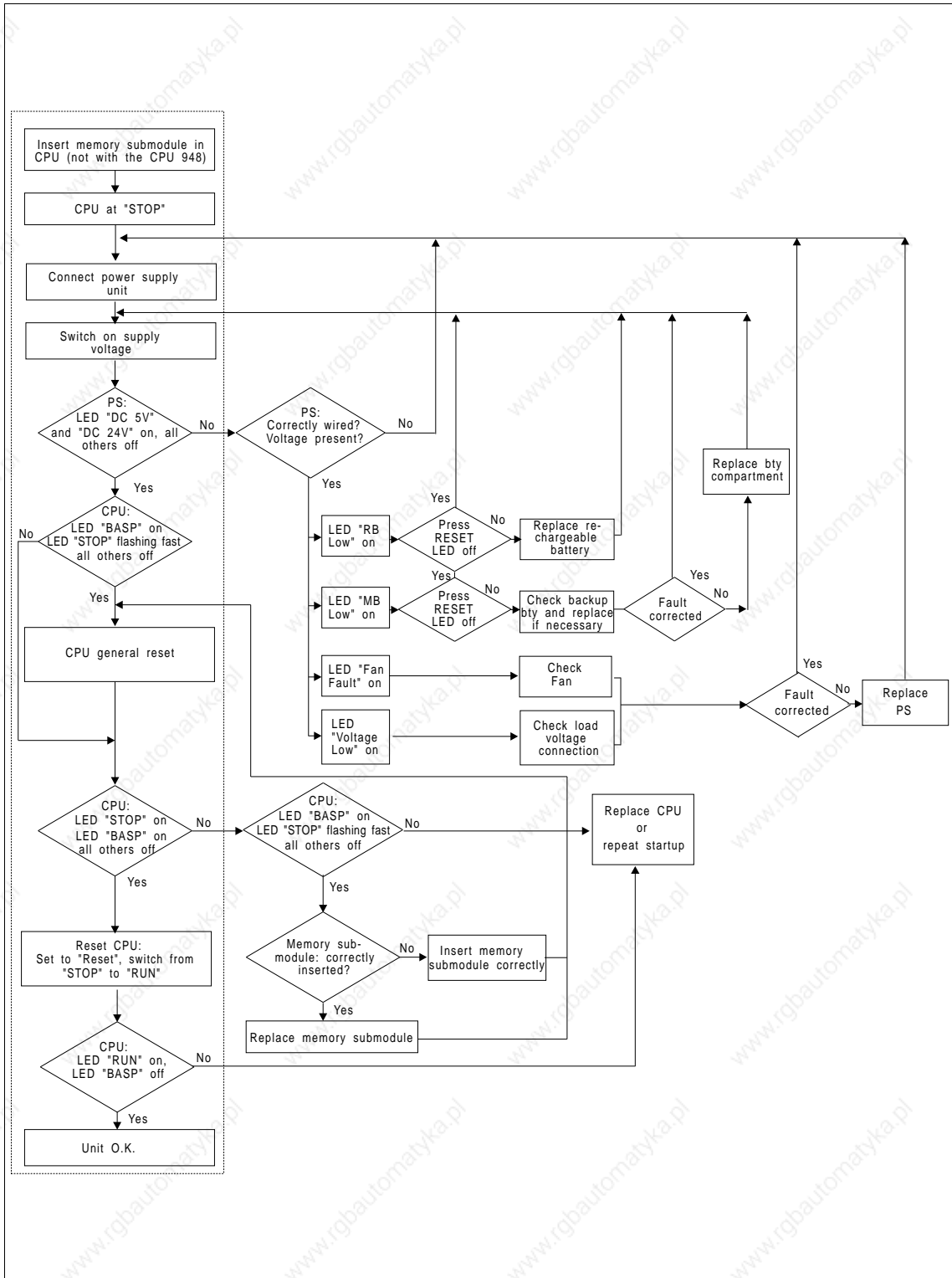

Figure 4-5 Startup

#### 4.1.4 Repair Guidelines

If measurements or testing become necessary whilst the unit is operational, accident prevention regulations VBG 4.0 must be observed, especially the permissible actions when working on active parts.

Only use tools that are suitable and approved for working on electrical equipment.

- Repair of an automation system may only be carried out by the **SIEMENS customer service** or by **qualified personnel** (see above).
- Always disconnect the AC power plug or open the isolating switch before opening the unit. Wait at least 8 minutes before pulling out and opening a power supply unit (see Section 4.2.3).
- Parts or components of a central controller may only be replaced by types listed in Catalog ST 54.1 or in the appendix to this manual.
- Fuses may only be replaced by the same type.
- Instructions for maintenance of the individual components can be found in the relevant chapters of this manual.



#### **Warning**

Unauthorized opening and improper repairs can result in death or serious personal injury as well as considerable damage.

#### 4.1.5 Technical Specifications

##### Important for the USA and Canada

The following approvals have been granted for the central controllers and expansion units:



UL Listing Mark  
Underwriters Laboratories (UL) to  
Standard UL 508, Report E85972



CSA Certification Mark  
Canadian Standards Association (CSA) to Standard  
C 22.2 No. 142, Report LR 63533C

4

<b>Unit safety</b>	
The unit complies with:	VDE 0160, IEC 65A (CO) 22
Protection against overvoltage	
Overvoltage Class 2 (not with PS -3NA12)	VDE 0160 A1
Class of protection	I
Type of protection (when empty slots are covered by dummy front plates)	IP 20 to IEC 529/DIN 40050
<b>Climatic ambient conditions (tested to DIN IEC 68-2/-1/2/3)</b>	
Ambient temperature in operation (supply air measured at lower air inlet of the unit)	0 to 55 °C
Transportation and storage temperature	-40 to 70 °C
Temperature variation: in operation during transportation and storage (when delivered at less than 0 °C, at least 3 h acclimatization because of possible condensation)	10 K/h max. 20 K/h max.
Relative humidity: in operation, during transportation and storage	95 % max. at 25 °C, no condensation
Altitude: in operation	-1000 m to +1500 m above sea level (1080 hPa to 860 hPa)
during transportation and storage	-1000 to +3500 m above sea level (1080 hPa to 660 hPa)
Pollutants: SO <sub>2</sub>	0.5 cm <sup>3</sup> /m <sup>3</sup> , 4 days
H <sub>2</sub> S	0.1 cm <sup>3</sup> /m <sup>3</sup> , 4 days
<b>Mechanical ambient conditions (tested to DIN IEC 68-2-6)</b>	
Vibration during operation	10 to 58 Hz (const. amplitude 0.075 mm 58 to 500 Hz (const. acceleration 1 g)

<b>Noise immunity, electromagnetic compatibility (EMC)</b>	
RFI suppression Limit value class	To VDE 0871 A
Conducted interference on AC supply lines (230 V AC) to IEC 801-4 (burst) to IEC 801-5 between two lines ( $\mu$ s pulses) to IEC 801-5 between line and ground ( $\mu$ s pulses)	2 kV 1 kV  2 kV
DC supply lines (24 V supply) to IEC 801-4 (burst)	1 kV
Signal lines (24 V DC) to IEC 801-4 (burst)	1 kV
Signal lines (230 V AC) to IEC 801-4 (burst)	2 kV
Immunity to discharge of static electricity to IEC 801-2 (ESD)	Immunity of 4 kV contact discharge (8 kV air discharge) is ensured with proper installation (see Chapter 3).
Immunity to RF interference	RF field to IEC 801-6 limit value class 3 (up to 200 MHz), corresponds to 3 V/m
<b>Mechanical data</b>	
Mechanical requirements	Installation in stationary equipment, subject to vibration; installation on ships and in vehicles if special installation rules are observed, but not on the engine.
Weight	approx. 14 kg
Dimensions (W x H x D)	482.6 x 432 x 310 mm

## 4.2 Expansion Units

This chapter contains information on the application, installation and operation of the following expansion units.

Order No. of Expansion Unit	Power Supply or Fan Subassembly
6ES5 183-3UA13 6ES5 183-3UA22	6ES5 955-3LC41 6ES5 955-3NC41
6ES5 184-3UA11 6ES5 184-3UA21	230/120 V AC fan subassembly 24 V DC fan subassembly
6ES5 185-3UA12 6ES5 185-3UA22 6ES5 185-3UA32 6ES5 185-3UA42	6ES5 955-3LC41 6ES5 955-3NC41 6ES5 955-3LF41 6ES5 955-3NF41
6ES5 187-5UA11	-

4

### Interface modules

Various interface modules (IMs) are available for communication between the CC and EUs and between EUs. Data transmission between CC and EU, and therefore between CPU and I/O module, is governed by the IM. A description of interface modules is given in Chapter 7.

The following table contains information on available types of expansion unit with their main features.

Version	EU Type	EU 183	EU 184	EU 185	EU 187
Own power supply		yes	no	yes	no
With fan		yes	yes	yes	no
With cable duct		yes	yes	yes	no
Number of slots		21	21	21	11
Pluggable modules:					
DI/DQ		yes	yes	yes	yes
AI/AQ		yes	yes	yes	yes
IP without page		yes	yes	yes	no
IP with page		no	no	yes	no
CP		no	no	yes	no
With interrupt processing		no	no	no	no

4.2.1

**Technical Description of the Expansion Units**

The design of the EUs is comparable to that of the CC: they comprise a compact housing with a type-dependent number of slots for modules and, according to the type of EU, a cable duct, an integral power supply unit or fan subassembly.

The mounting dimensions of the EU 183U, EU 184U and EU 185U are the same as those of the 135U/155U CC (see Figures 4-2 and 4-4). The EU 187U has neither power supply unit nor cable duct. Its overall height and depth are therefore different from those mounting dimensions of the other EUs.

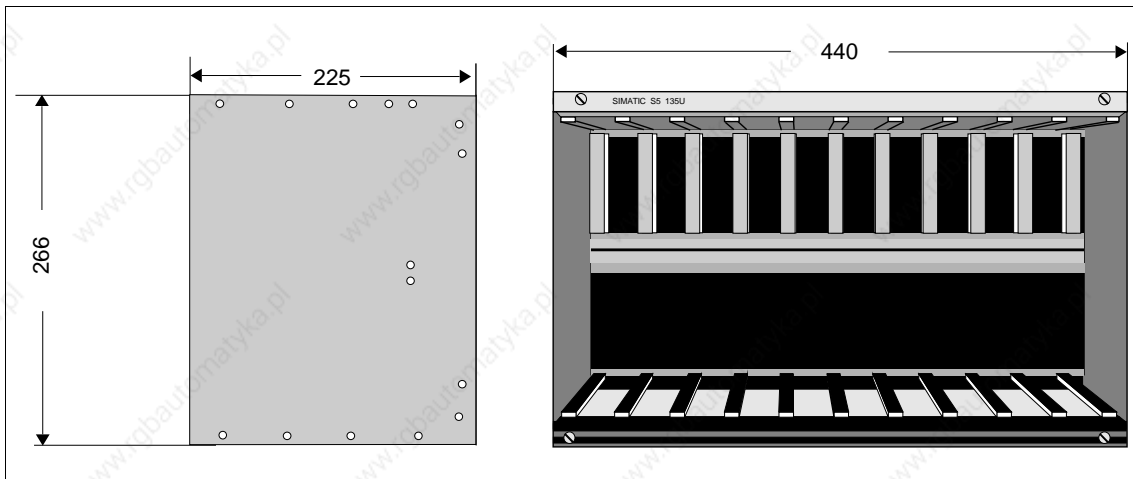

Figure 4-6 Mounting Dimensions of the EU 187U

**Modules and slots assignments of the expansion units**

The following tables show which modules can be inserted at which slots.

Modules and slot assignments of the EU 183U

Slot No.	3	11	19	27	35	43	51	59	67	75	83	91	99	107	115	123	131	139	147	155	163		
Module type																							
IM 300																							
IM 310, IM 314, IM 318	■																						
IM 317	■																						
IM 312-3																							
DI, DQ, AI, AQ	■	■	■	■	■	■	■	■	■	■	■	■	■	■	■	■	■	■	■	■	■	■	■
Signal pre-processing modules (IPs)	See current Catalog ST 54.1 for slot numbers																						
Monitoring module 313	■																						■

## Modules and slot assignments of the EU 184U

Slot No.	3	11	19	27	35	43	51	59	67	75	83	91	99	107	115	123	131	139	147	155	163		
Module type																							
IM 312-5																							
DI, DQ, AI, AQ																							
Signal pre-processing modules (IPs)	See current Catalog ST 54.1 for slot numbers																						
Monitoring module 313																							

## Modules and slot assignments of the EU 185U

4

Slot No.	3	11	19	27	35	43	51	59	67	75	83	91	99	107	115	123	131	139	147	155	163		
Module type																							
Coordinator 923 C																							
Communication processors (CPs)																							
IM 314 R																							
IM 300																							
IM 310, IM 314 IM 318 IM 317																							
IM 308																							
DI, DQ, AI, AQ																							
Signal pre-processing modules (IPs)	See current Catalog ST 54.1 for slot numbers																						
Monitoring module 313																							

Slots 19 to 75 are programmer MUX-capable

## Modules and slot assignments of the EU 187U

Slot No.	3	19	35	51	67	83	99	115	131	147	163
Module type											
IM 312-5											
DI, DQ, AI, AQ											
Monitoring module 313											

### 4.2.2

#### Installing the Expansion Units

Like a CC, the EUs are designed for installation in cabinets, in racks and on walls. To install an expansion unit, therefore, refer to the description for the CC and Chapter 3.

### 4.2.3

#### Technical Specifications of the Expansion Units

The technical specifications of the expansion units are the same as those of the central controller except for the following (see Section 4.1.5).

- Weight    EU 183U: approx. 14 kg  
              EU 184U: approx. 13 kg  
              EU 185U: approx. 14 kg  
              EU 187U: approx. 11 kg
- Dimensions: EU 187U: 440 x 266 x 225 mm



## 4.3 Power Supply Units

Power supply units are part of the S5-135U/155U central controllers and of the EU 183 and EU 185 expansion units.

### 4.3.1 Product Overview

The following section provides an overview of power supply types, their functions, indicators and controls and their inputs and outputs.

#### Power supply types

Your CC/EU contains one of the following power supply units (PSUs):

Type of PSU (Designation)	Input Voltage	Output Voltage	Application
6ES5 955-3LC41	120 V AC 230 V AC (selectable)	5V/18 A DC 15V/0.5 A DC 24V/1 A DC	Central controller 6ES5 188-3UA11 Expansion units 6ES5 183-3UA13 6ES5 185-3UA12
6ES5 955-3LF41	120 V AC 230 V AC (selectable)	5V/40 A DC 15V/2 A DC 24V/2.8 A DC	Central controller 6ES5 188-3UA21 Expansion unit 6ES5 185-3UA32
6ES5 955-3NC41	24 V DC	5V/18 A DC 15V/0.5 A DC 24V/1 A DC	Central controller 6ES5 188-3UA31 Expansion units 6ES5 183-3UA22 6ES5 185-3UA22
6ES5 955-3NF41	24 V DC	5V/40 A DC 15V/2 A DC 24V/2.8 A DC	Central controller 6ES5 188-3UA51 Expansion unit 6ES5 185-3UA42

4

The 5 V and 15 V output voltages are regulated; the 24 V output voltage has coarse stabilization.

All four power supply units have safe electrical separation according to VDE 0805/EN 60950.

#### Note

These power supply units are only intended for use with CCs/EUs.

### **Basic functions**

The power supply units offer the following functions:

- **System power supply**  
All the system voltages required for operation of the modules in a CC or EU are supplied.
- **Power supply for backup (in the CC and EU 185)**  
A lithium battery and a rechargeable battery ensure data backup when the system voltage is switched off or fails.
  - The lithium battery remains in the CC/EU and ensures backup, even during replacement of the power supply unit
  - During replacement or failure of the lithium battery, the rechargeable battery in the power supply continues to provide backup and ensures that no data are lost.
  - Situated on the front plate of the power supply unit are two sockets for input of an external battery voltage.
- **Heat removal**  
Three independent fans which are individually replaceable during operation remove the dissipated power. If a fan fails, the supply voltage for this fan is switched off and the other two fans continue operation at increased speed.

### **Monitoring functions**

The power supply units contain monitoring functions to detect the following faults:

- Failure of system voltage
- Failure of output voltages
- Failure of an externally applied 24 V DC load voltage (voltage monitor)
- Fan failure or inadequate air flow
- Battery failure
- Rechargeable battery failure

In this context, a voltage failure is equivalent to a drop of the monitored voltage below a preset limit (see Section 4.3.6 of the Technical Specifications).

### **Signalling functions**

The failure of a monitored function is signalled by the power supply units:

- via LED indicators on the front plate;
- via relays with which signalling circuits can be switched;
- via signals to the S5 bus.

**Inputs and outputs**

Based on the example of the 6ES5 955-3LF41 power supply unit, the following figure shows the arrangement of inputs and outputs on the front plate of the power supply units:

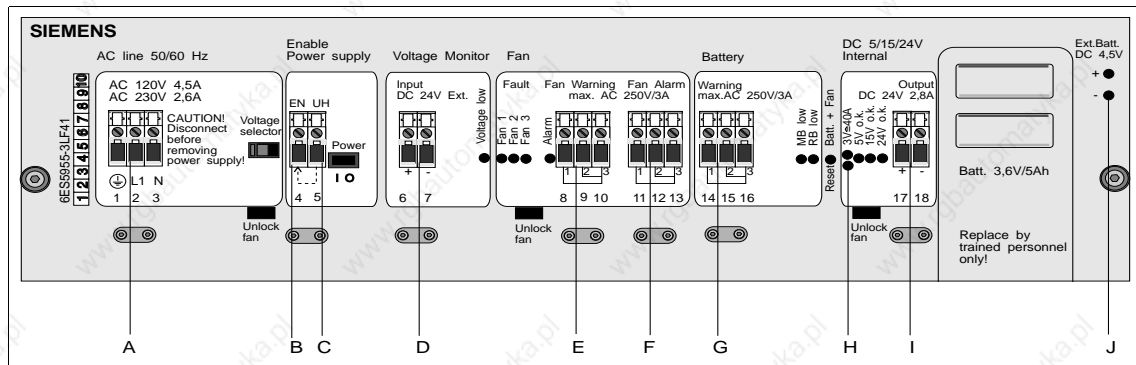

The following table provides an overview of the labelling and purpose of the inputs and outputs:

ID	Label	Element	Purpose
A	AC 120V 4.5A AC 230V 2.6A	Screw terminals 1, 2, 3	AC connection and protective conductor
B	EN	Screw terminal 4	Enable Power Supply Control input for power supply
C	UH	Screw terminal 5	Supply for EN
D	Input DC 24V Ext.	Screw terminals 6 and 7	Voltage Monitor Monitors 24 V load voltage for > 16 V
E	Fan Warning max. 250V/3A	Screw terminals 8, 9, 10 (relay)	Indicates failure of a fan
F	Fan Alarm max. 250V/3A	Screw terminals 11, 12, 13 (relay)	Indicates failure of at least two fans and inadequate air flow; if jumper set accordingly, output enable is the second signal source
G	Battery Warning max. 250V/3A	Screw terminals 14, 15, 16 (relay)	Indicates that lithium bty or rechargeable bty has dropped below limit
H	3V $\hat{=}$ 40A	2 test sockets	Current measurement sockets for test purposes only; no continuous operation; linearity range 0.5 V/6.6 A to 3 V/40 A
I	Output DC 24V 2.8A	Screw terminals 17, 18	Enable voltage for I/O modules
J	Ext.Batt. 4.5V DC	2 input sockets	Input for an external 4.5 V backup voltage

**Indicators and controls**

Apart from the jumpers, the indicators and controls of the power supply unit are fitted on the front plate. The following figure shows their locations:

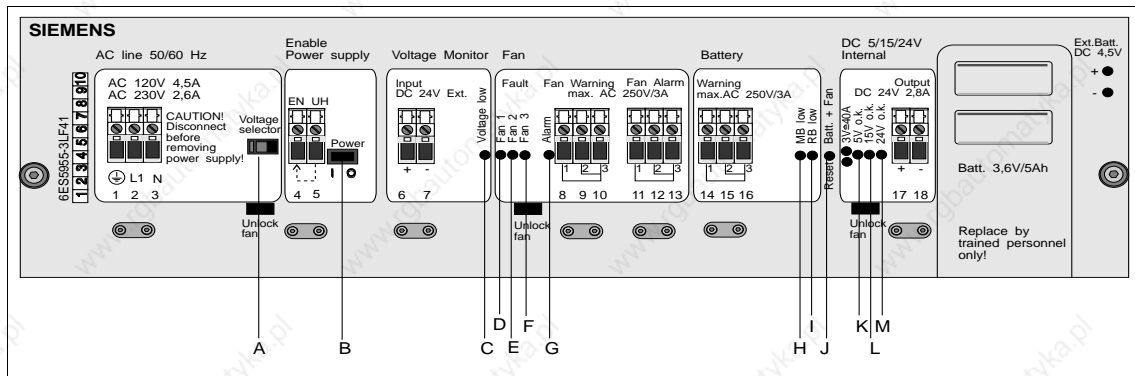

The labelling and purpose of the indicators and controls are given in the following table:

ID	Label	Element	Purpose
A	Voltage selector <sup>1)</sup>	Switch	Voltage selector switch: choice of 120 V or 230 V
B	Power	Switch	Standby On/Off switch (not system On/Off switch)
C	Voltage low	Red LED	Low voltage at load voltage monitor input
D	Fan 1	Red LED	Failure of Fan 1
E	Fan 2	Red LED	Failure of Fan 2
F	Fan 3	Red LED	Failure of Fan 3
G	Alarm	Red LED	Indicates failure of at least two fans; if jumper is set accordingly, output enable is the second signal source.
H	MB low	Yellow LED	Lithium battery/external battery voltage below preset limit (3 V)
I	RB low	Yellow LED	Rechargeable battery voltage below preset limit (3 V)
J	Reset Batt.+Fan	Pushbutton	Reset of LEDs D, E, F, G, H, I when fault cleared
K	5V o.k.	Green LED	Lights up to indicate output voltage within permissible range
L	15V o.k.	Green LED	Lights up to indicate output voltage within permissible range
M	24V o.k.	Green LED	Lights up to indicate output voltage within permissible range

<sup>1)</sup> Only on the 6ES5 955-3LC41 and 6ES5 955-3LF41

### 4.3.2

#### Setting and Connecting the Power Supply Unit

Before placing your power supply unit in operation, you must carry out certain steps according to your requirements with respect to power supply behavior in the event of a fault.

Power supply units are delivered in the following state:

- Fitted in the CC or EU frame which you ordered
- With preset jumpers
- AC line voltage set to 230 V

If you wish to retain this setting, you can skip Steps 2 to 4 and 9. If you do not wish to fit a filter subdrawer, skip step 8.

Step	Action	
1	Check the setting and cabling	
2	Remove the power supply unit	If required
3	Set the jumpers	If required
4	Fit the power supply unit	If required
5	Wire the power supply unit to the installation (including fitting and isolating device to disconnect the AC line voltage)	
6	Fit the lithium battery	
7	Remove the right-hand fan and connect the rechargeable battery	
8	Fit the filter subdrawer	If required
9	Set the voltage selector switch (preset to 230 V)	If required
10	Switch the PSU on for the first time	

**Brief instructions for startup** The following table shows the procedure for placing the power supply unit (PSU) in operation without changing the jumper setting:

Stage	Description
1	Fit the PLC, allowing for clearances for access in the event of repairs and for adequate ventilation. Observe chassis grounding.
2	Fit the lithium battery in the battery compartment on the right front of the power supply unit (ensure correct polarity).
3	Remove the right-hand fan subassembly, plug in the red positive lead of its rechargeable battery and reinsert the fan.
4	Check that the voltage selector switch is set to your desired voltage.
5	Connect the 24 V load voltage leads to the "Voltage Monitor" terminals.
6	When connecting the AC leads, fit an isolating device to isolate the power supply unit from the AC line voltage.
7	Connect the primary voltage leads and the protective conductor.
8	Switch on the primary voltage and the 24 V load voltage.
9	Use the "Power" switch to switch on the power supply unit.
10	If the required basic load is in circuit, no red LED lights up and the power supply unit is operational.

4

All activities relating to startup of the power supply units are described in detail in the following.

**Establishing the setting and cabling**

*Establishing the jumper settings*

The power supply unit is delivered with the settings shown in bold print in the following table.

Mark your chosen settings in the right-hand column and use this chart for the subsequent implementation.

Function Selection	Jumper	Setting	Application/Note	(✓)
Battery monitor - switched on for rechargeable battery and battery - switched on for battery and off for rechargeable battery - switched off	MM - NN MA - NA	<b>closed</b> <b>closed</b>	Redundant backup	
	MM - NN MA - NA	<b>closed</b> open	If, for example, no redundancy is required in backup, i.e. the rechargeable battery is missing	
	MM - NN MA - NA	open irrelevant	e.g. monitoring is not needed for EU without backup	
Reaction of battery monitoring following battery failure - /BAU signal active following return of line voltage - /BAU signal active following return of line voltage and during operation	MB - NB	<b>open</b>  closed	The possibility of evaluating the battery monitoring during operation is dependent on the CPU in use	
After failure of more than one fan or inadequate air flow - PSU shutdown - No PSU shutdown	F-R	<b>closed</b>  open	Caution: To prevent overheating of modules, the PSU must be shut down after 60 s at the latest (e.g. by time relay)	
Voltage monitor - switched off - switched on	BA-EX	closed  <b>open</b>	Monitoring of load voltage input switched off Monitoring of load voltage input switched on	
Relay alarm - driven by fan monitor and output inhibit - driven only by fan monitor	BB-AA	closed  <b>open</b>	Fault message initiated by fan failure/output inhibit active; can be signalled to control room, for example. Fault message initiated by fan failure; can be signalled to control room, for example.	

If your selection is the same as all the settings marked in bold print, you need not change the jumper settings.





**Establishing the wiring**

Wiring of the power supply unit must be planned within the scope of wiring of the entire control system. The information required for the purpose and decision-making aids, e.g. for local or central grounding, can be found in Chapter 3: Installation Guidelines.

**Establishing the signalling circuits**

Three relay outputs allow you to install additional external signalling circuits for fault states, e.g. to connect a cabinet lamp or horn.

The following table contains the information required on the relay states:

Relay	 (Normal Operational State)	 (Fault State/Idle State)
Fan Warning	All fans are in order.	One or more fans have failed.
Fan Alarm	Adequate air flow, at least two fans are running.	Inadequate air flow or at least two fans have failed.
Battery Warning	Lithium battery and rechargeable battery are in order ( $U_{\text{batt ext}}$ not connected)	Lithium battery or rechargeable battery has failed (no $U_{\text{batt ext}}$ )

4

**Setting up the control input for the power supply**

The following applies to the 5 V supply for terminal EN (Enable Power Supply):

- Input EN monitors the voltage for  $< 3.6 \text{ V}$ ; it enables the output voltage at  $3.6 \text{ V}$ .
- If two or more units are to be controlled jointly, connect input EN of the PSU in the central controller to the EN inputs of the PSUs in the expansion unit. Connect the auxiliary voltage  $U_{\text{H}}$ , for example, to these inputs. In the event of failure of the PSU in the central controller, all units will then be switched off with the appropriate jumper settings. Not more than 7 EN inputs may be connected to one  $U_{\text{H}}$  output (front terminal).

Establishing the cables

The following applies to selecting the cables for the terminals:

Terminals	Cabling	Max. Permissible Conductor Cross-Sections
Power supply AC line    DC line	Phase L 1	4 mm <sup>2</sup> solid or 2.5 mm <sup>2</sup> flexible
	Neutral N	4 mm <sup>2</sup> solid or 2.5 mm <sup>2</sup> flexible
	Protective cond. PE	4 mm <sup>2</sup> solid or 2.5 mm <sup>2</sup> flexible
	Positive L+	4 mm <sup>2</sup> solid or 2.5 mm <sup>2</sup> flexible
	Chassis 0 V M	4 mm <sup>2</sup> solid or 2.5 mm <sup>2</sup> flexible
	Protective cond. PE	4 mm <sup>2</sup> solid or 2.5 mm <sup>2</sup> flexible
Load voltage input (Voltage monitor, Ext. 24 V DC)	24 V input (may be omitted if jumper BA-EX is closed)	4 mm <sup>2</sup> solid or 2.5 mm <sup>2</sup> flexible
Enable power supply	Set jumper from EN-U <sub>H</sub> or apply ≥ 3.6 V voltage at EN, with respect to output chassis ground	4 mm <sup>2</sup> solid or 2.5 mm <sup>2</sup> flexible
Relay terminals, also suitable to 230 V AC / 3 A		4 mm <sup>2</sup> solid or 2.5 mm <sup>2</sup> flexible
Monitor output for 24 V		4 mm <sup>2</sup> solid or 2.5 mm <sup>2</sup> flexible

**Note**

A voltage of more than 50 V must not develop between the output voltages and the protective conductor potential.

## Removing the power supply unit

### When to remove the PSU

You must remove the power supply unit if you:

- change the jumper settings;
- send the power supply unit in for repair.



### Caution

Power supply units may only be removed when power is switched off.

If 230 V I/O modules are fitted, you must ensure before removing the power supply unit that the subrack is grounded when the PSU is removed, or the 230 V supply for these modules is switched off.

4

When the power supply unit is removed, the connection between backup battery and backplane bus remains; this ensures backup of the user program.

### How to remove the PSU

Proceed according to the following steps to remove the power supply unit:

Step	Action
1	Switch the Power switch off (standby On/Off).
2	Disconnect the power supply unit from the AC line voltage.
3	Detach the connections of all leads from the front terminals.
4	 <b>Important</b> Before pulling out the PSU, wait at least 8 minutes after switching off the power so that the electrolytic capacitors can discharge.
5	Slacken the fixing screws on the left and right of the PSU.
6	Pull the PSU out. There are grips to pull it out under the unlock fan openings.

### Setting the jumpers

#### Locations of jumpers

The jumper locations are given in the following figure:

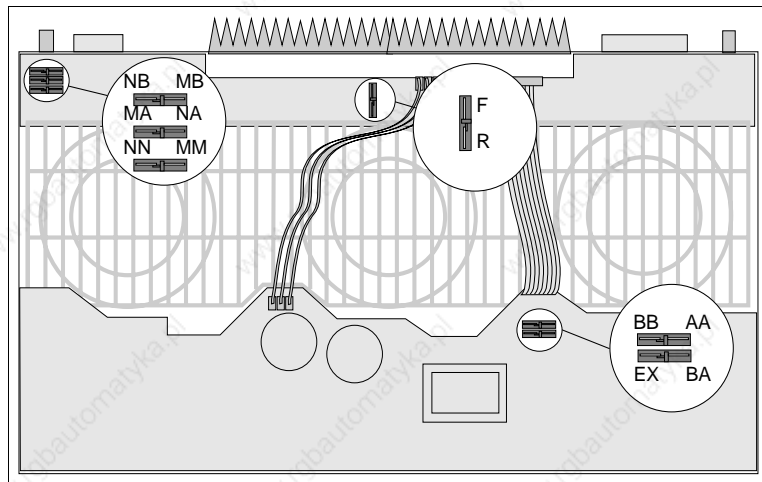

#### Setting the jumpers

To change the jumper settings, it is best to use pincers or a fine screwdriver.

Proceed as follows to change the jumper settings:

<b>IF...</b>	<b>THEN...</b>
You wish to open the jumper,	press the flexible jumper wire down and pull it out.
You wish to close the jumper,	press the flexible jumper wire down and insert it.

**Fitting the power supply unit****Caution**

For safety reasons, the power supply unit may only be operated in the housing provided for the purpose.  
The protective conductor must always be connected.

**How to fit the PSU**

After carrying out setting, installation and repair work, proceed according to the following steps to refit the power supply unit in the frame:

Step	Action
1	Push the PSU into the guide rails until it engages. You can use one hand to support the PSU from below; this facilitates fitting in the guide rails.
3	Secure the PSU with the fixing screws on the left and right of the unit.   <b>Caution</b> Since the fixing screws also provide the protective conductor connection to the subrack, they must be tightened before the power cable is connected.

4

**Wiring the power supply unit****How to wire the PSU**

Wiring of the PSU is carried out within the scope of overall wiring for your controller, according to your requirements and the section entitled "Establishing the settings and cabling".

Terminals with dangerous touch-voltages must be covered with caps. Use only the original self-tapping screws provided when you fit the caps for the first time.

### Fitting the lithium battery

#### Notes relating to the lithium battery

The backup battery (Type C) contains lithium (more than 0.5 g) and is delivered separately from the power supply unit, because of special shipping regulations.



#### Caution

Improper replacement of the battery can result in explosion hazard. It should only be replaced by the same type or an equivalent one recommended by the manufacturer. Used batteries should be disposed of according to the manufacturer's instructions.

The backup battery must be fitted before the programmable controller is placed in operation. Without a backup voltage, the PLC will remain in the Stop state after system voltage is switched on.

Only use battery compartments marked -A1155-B21 (red label).

#### How to fit the lithium battery

Fit the lithium battery in the following steps:

Step	Action
1	Slide the battery compartment cover (A) downwards.
2	Pull the battery compartment (B) out.
3	Insert the lithium battery in the battery compartment.  <b>Important</b> Ensure correct polarity.
4	Slide the battery compartment in.
5	Close the cover.

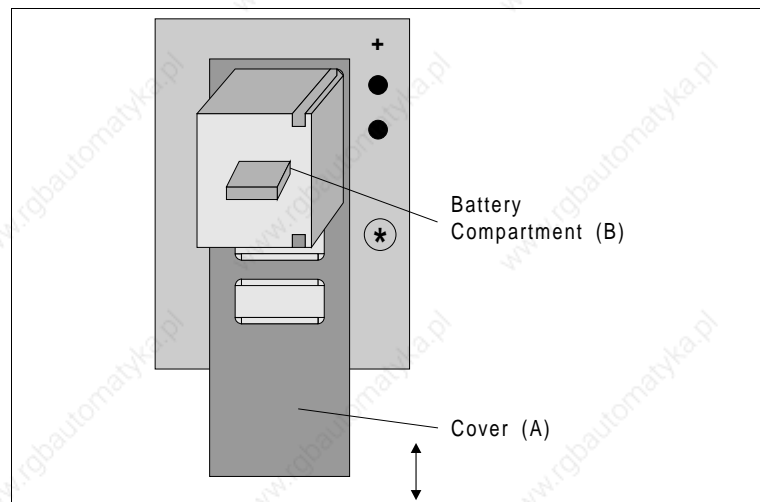

**Caution**

Do not throw new or discharged batteries into a fire and do not solder onto the cell (max. temperature 100 °C (212 °F)). Do not recharge them: there is a risk of explosion. Do not open the battery, and only replace it with the same type. Replacements should only be procured from SIEMENS (see ordering information for the order number). This ensures that you have a short-circuit protected type.

The lithium battery is subject to the dangerous goods regulations. Observe these when dispatching the battery. For example, you can use the original packaging.

All batteries with a residual charge should be discharged with a 10 ohm resistor or flashlight bulb until a no-load voltage can no longer be measured.

Lithium thionyl chloride batteries without residual charge should be sent in for recycling.

**Removing the right-hand fan and connecting the rechargeable battery**

*Location of fans and rechargeable battery*

*How to connect the rechargeable battery*

The three fans are situated under the power supply unit. The rechargeable battery is fitted in the right-hand fan subassembly.

Proceed according to the following steps:

Step	Action	Result
1	Place one hand under the right-hand fan; with the other hand, insert a screwdriver (DIN 5265, blade width 3.5-6.5 mm) into the right-hand unlock fan opening.	When the screwdriver is pulled out, the snap hook is released. By pulling on the round hole on the underside of the fan subassembly it swings down and can be pulled out.
2	Connect the red connecting cable to the battery.	The battery is connected.
3	Insert the fan subassembly in the housing with the tab situated at the rear, and swivel it up.	The fan subassembly engages.

*Releasing the fan lock*

The following figure shows how to release the fan lock:

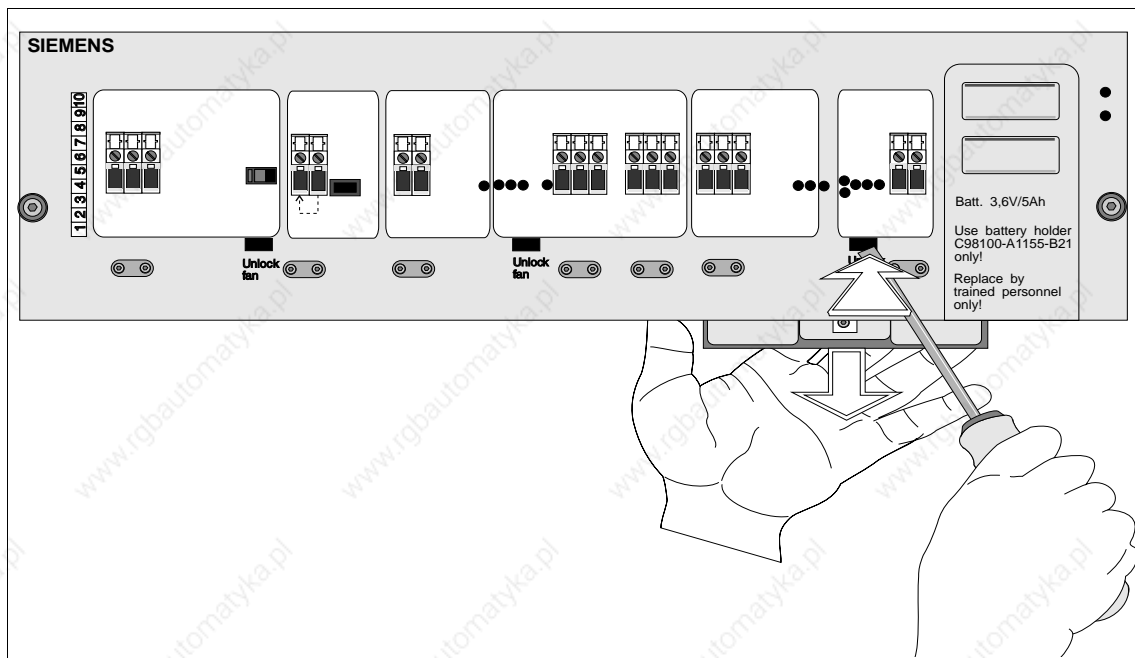



**Fitting the filter subdrawer****Option**

The filter subdrawer, two plug-in guide rails and the corresponding filter mats are available as an option (see the ordering instructions for the order numbers)

**Where to fit the filter subdrawer**

To insert a filter, you must secure the filter subdrawer to the lower side of the power supply unit housing.

**How to fit the filter subdrawer**

Proceed as follows:

**4**

Step	Action
1	Insert the tabs of the two guide rails in the openings provided on the lower side of the PSU (right and left).
2	Insert a filter mat in the filter subdrawer and secure it with the gripper material.
3	Position the filter subdrawer in the guide rails, push it back and swivel it up so that it engages.

**Setting the voltage selector switch****How to set the voltage selector switch**

On the AC power supply units, the voltage selector switch is situated on the front plate and marked Voltage Selector. You can select a voltage of 120 V or 230 V. The factory setting is 230 V.

Set the voltage according to your requirements:

Step	Action
1	Disconnect the power supply unit from the line voltage.
2	Use a screwdriver to remove the transparent cover.
3	Set the voltage selector switch to your required voltage.
4	Refit the transparent cover.

**Switching on the power supply unit for the first time**

*How to switch on the power supply unit*

When you have made all the settings, switch the power supply unit on as follows

Step	Action	Result
1	Switch the power supply unit on with the Power switch.	
2	Switch the system voltage on.	If the required basic load (see Section 4.5.6, Technical Specifications) is in circuit, the power supply unit will start.  The green LEDs "5V o.k." "15V o.k." "24V o.k." light up.  The fans run.

### 4.3.3

#### Fault Indications/Fault Diagnostics

This section explains where and how faults are indicated, and how to interpret the indications.

#### Where are faults indicated?

Faults of the system power supply, load power supply, battery supply and fans are indicated by LEDs on the front plate of the power supply unit.

#### How are faults indicated and interpreted?

When all monitoring circuits are switched on (jumper settings), the following indications can appear:

4

LED Indication	Cause	Action
"Voltage low" LED lights up.	The voltage at the voltage monitor is less than 14 V.	
"MB low" LED lights up.	The lithium battery has failed or the battery compartment is faulty. (Precondition: no external battery voltage is present).	Replace backup battery or battery compartment
"RB low" LED lights up.	The rechargeable battery has failed.	Replace rechargeable battery
"Fan 1" LED lights up.	The speed of Fan 1 has dropped or Fan 1 has stopped.	Replace fan
"Fan 2" LED lights up.	The speed of Fan 2 has dropped or Fan 2 has stopped.	Replace fan
"Fan 3" LED lights up.	The speed of Fan 3 has dropped or Fan 3 has stopped.	Replace fan
At least 2 "Fan" LEDs light up as well as the "Alarm" LED.	At least 2 fans have failed.	Replace fan
All 3 "Fan" LEDs flash and the "Alarm" LED lights up.	The air flow is inadequate.	Replace filter mat

For all faults, the indication appears 6 s after the monitor has responded. (Exception: The "Voltage low" LED lights up immediately.)

*Other faults*

Other faults can be indicated by the green LEDs on the front plate going off.

<b>Indication</b>	<b>Possible Cause</b>	<b>Action</b>
Green LEDs go off and the power supply fails.	The Enable jumper is out of place	Check the jumper.
	Latching Off-switching by overvoltage at output	Switch the supply voltage off and on again. If this does not clear the fault, there is an internal fault.
	Internal fault in the PSU	Send in the PSU for repair.

## Fans and fan monitoring

The following table contains several examples.

**Requirement:**

Enable EN present, jumper F - R closed

Causes		LED Indication		Relay		Reaction
Fans	Air filter/air flow	Fan 1 to fan 3	Alarm	Fan Warning	Fan Alarm	
All fans in order	In order	All LEDs dark	Dark	-	-	5 V, 15 V, 24 V present, fans 1 to 3 running
One fan failed	In order	Corresponding LED lit	Dark	Active	-	5 V, 15 V, 24 V present, faulty fan switched off, the other two fans running at increased speed
Two fans failed	In order	Corresponding LEDs lit	Lit	Active	Active	Power supply switches off
All fans in order	Dirty/halved	All LEDs flashing	Lit	-	Active	Power supply switches off

4

**Requirement:**

Enable EN present, jumper F - R open

Causes		LED Indication		Relay		Reaction
Fans	Air filter/air flow	Fan 1 to fan 3	Alarm	Fan Warning	Fan Alarm	
All fans in order	In order	All LEDs dark	Dark	-	-	5 V, 15 V, 24 V present, fans 1 to 3 running
One fan failed	In order	Corresponding LED lit	Dark	Active	-	5 V, 15 V, 24 V present, faulty fan switched off, the other two fans running at increased speed
Two fans failed	In order	Corresponding LEDs lit	Lit	Active	Active	5 V, 15 V, 24 V present, defective fan switched off, one fan running with increased speed
All fans in order	Dirty/halved	All LEDs flashing	Lit	-	Active	5 V, 15 V, 24 V present, fans 1 to 3 running

**Note:**

When the jumper "BB - AA" is closed the relay "Fan Alarm" is also activated by the "output inhibit" signal.

**Rechargeable battery and battery monitoring**

The following table contains several examples.

Causes		Jumpers	Relay Battery Warning	LED Indication		
Recharge- able battery	Battery or external supply			RB	MB	/BAU
In order	In order	MA-NA closed MN-NN closed MB-NB open	-	Dark	Dark	Inactive
Faulty	In order	MA-NA closed MN-NN closed MB-NB open	Active	Lit	Dark	Inactive
In order	Faulty	MA-NA closed MN-NN closed MB-NB open	Active	Dark	Lit	Inactive
Faulty	Faulty	MA-NA closed MN-NN closed MB-NB open	Active	Lit	Lit	Active
Not monitored	In order	MA-NA open MN-NN closed MB-NB open	-	Dark	Dark	Inactive
Not monitored	Faulty	MA-NA open MN-NN closed MB-NB open	Active	Dark	Lit	Active
Not monitored	Not monitored	MA-NA irrelevant MN-NN open MB-NB open	-	Dark	Dark	Inactive

**Note:**

Jumper MB - NB open: when line voltage returns the signal /BAU (battery failure) is activated by a corresponding error.

Jumper MB - NB closed: when line voltage returns and during operation the signal /BAU (battery failure) is activated by a corresponding error.

#### 4.3.4 Maintenance and Repairs

##### *Lithium battery*

The lithium battery should be replaced when a battery failure is indicated. The backup times of the lithium battery are given in the following table:

I <sub>backup</sub> mA	0.25	1	2	3	4	5
New battery, backup time in weeks	81.5	27.4	14.5	9.9	7.5	6.0
Battery 3 years old, backup time in weeks	64.2	21.6	11.5	7.8	5.9	4.8

4

##### *Fans*

If a fan fails, replace it as quickly as possible. The behavior of the power supply in the event of fan failure is described in Section 4.3.5.

##### *Rechargeable battery*

The rechargeable battery should be replaced at regular intervals (service life of 6 years at 40 °C (104 °F) ambient temperature). With a failed power supply and failed battery, the backup times of the rechargeable battery are as follows:

I <sub>backup</sub> mA	0.25	1	2	3	4	5
Backup time in weeks	18.8	6.3	3.4	2.3	1.7	1.4

##### *Filter mat*

The replacement intervals for the filter mat (with the air filter option) depend on the ambient conditions under which the power supply unit is in operation.

**Replacing the lithium battery**

The lithium battery can be replaced without memory loss if the PSU is switched on, the rechargeable battery is in order or you apply an external (4.5 V) voltage to the "Ext.Batt." terminals.

*How to replace the lithium battery*

Replace the lithium battery in the following steps:

Step	Action
1	Slide the battery compartment cover down.
2	Pull the battery compartment out.
3	Remove the old lithium battery from the battery compartment by inserting a screwdriver through a hole in the compartment base to push the battery upwards.
4	Insert the new lithium battery in the battery compartment <b>Important</b> Ensure correct polarity.
5	Slide the battery compartment in.
6	Close the cover.
7	Press the Reset button.  Result (only with PSU on): - "MB low" LED goes off. Contacts 14 and 15 of the Battery Warning relay are bridged.



**Replacing a fan****Location of the fans**

The three fans are situated at the bottom of the power supply unit and can be individually replaced during operation.

**Before replacement**

If you operate your power supply with a filter, you must first release the filter subdrawer and pull it out before you can replace a fan (see Section entitled "Replacing the filter mat").

**How to replace a fan**

The following steps are necessary to replace a fan:

**4**

Step	Action	Result								
1	Place one hand under the fan you wish to replace, and use the other hand to insert a screwdriver (DIN 5265, blade width 3.5-6.5 mm) into the unlock fan opening.	When the screwdriver is pulled out, the snap hook is released. By pulling on the round hole on the underside of the fan sub-assembly it swings down and can be pulled out.								
2	<ul style="list-style-type: none"> <li>- If this is not the right-hand fan subassembly, go directly to Step 3 after removing the old fan subassembly.</li> <li>- If this is the right-hand fan subassembly, proceed as follows:</li> </ul> <table border="1" style="margin-left: 20px;"> <thead> <tr> <th>Step</th> <th>Action</th> </tr> </thead> <tbody> <tr> <td>2a</td> <td>Unscrew the rechargeable battery from below.</td> </tr> <tr> <td>2b</td> <td>Disconnect the connecting cable.</td> </tr> <tr> <td>2c</td> <td>Insert the rechargeable battery in the new fan subassembly (see section entitled "Replacing the rechargeable battery") and reconnect the connecting cable.</td> </tr> </tbody> </table> <p><b>Important</b> Ensure correct polarity.</p>	Step	Action	2a	Unscrew the rechargeable battery from below.	2b	Disconnect the connecting cable.	2c	Insert the rechargeable battery in the new fan subassembly (see section entitled "Replacing the rechargeable battery") and reconnect the connecting cable.	
Step	Action									
2a	Unscrew the rechargeable battery from below.									
2b	Disconnect the connecting cable.									
2c	Insert the rechargeable battery in the new fan subassembly (see section entitled "Replacing the rechargeable battery") and reconnect the connecting cable.									
3	Insert the new fan subassembly with the tab at the rear into the housing, and swivel it up.	The fan subassembly engages.								

Releasing the fan lock

The following figure shows how to release the fan lock:

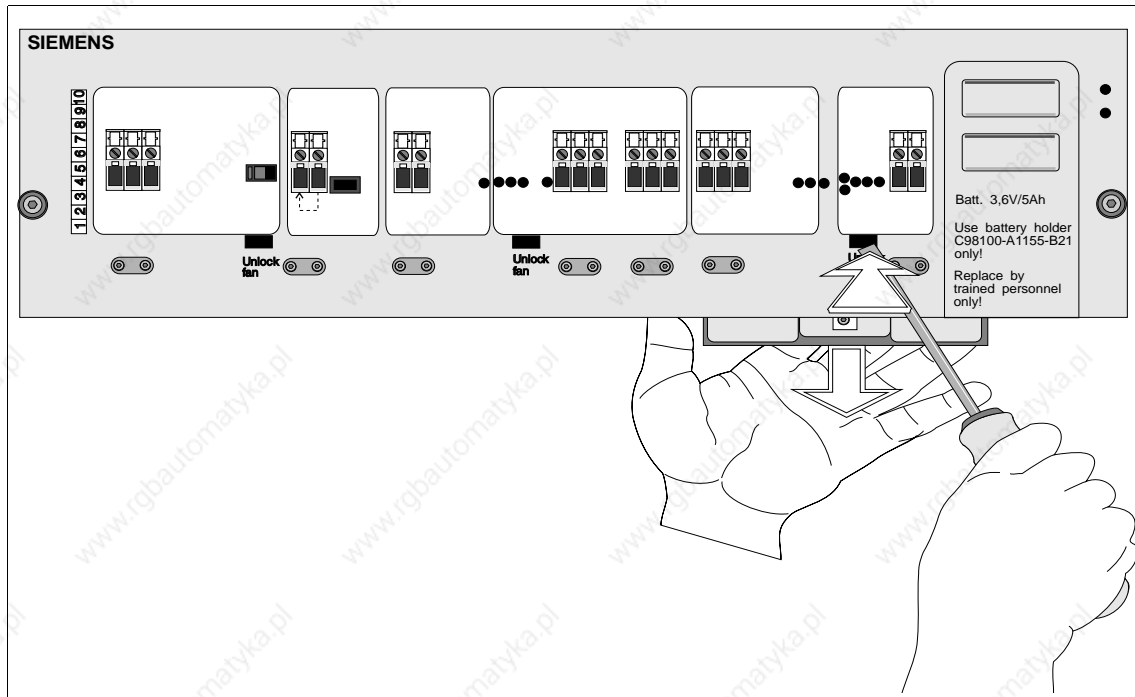

After replacement

After replacement, press the Reset button, the monitor will become active 6 secs after the Reset button is pressed.

IF...	THEN...
the relevant "Fan" LED goes off,	the fan is correctly installed.
the relevant "Fan" LED does not go off,	the fan is incorrectly installed. Make a step-by-step check to ensure correct replacement.
the relevant "Fan" LED goes off but the "Warning" relay does not pick up,	another fan has failed and another "Fan" LED lights up. Replace the second fan also.

## Replacing the rechargeable battery

### Location of the rechargeable battery

The rechargeable battery is situated in the right-hand fan subassembly.



#### Caution

Do not place the rechargeable battery in contact with fire or heat and do not short-circuit it.

The rechargeable battery must not be destroyed or disassembled. Nickel-cadmium batteries contain an alkali electrolyte which can harm the skin and damage clothing. If your skin or your eyes make contact with the electrolyte, rinse immediately with clean water and consult a doctor.

4

### Before replacement

If you operate your power supply with a filter, you must first release the filter subdrawer and pull it out before dismantling the right-hand fan and replacing the rechargeable battery (see section entitled "Replacing the filter mat").

### How to replace the rechargeable battery

The rechargeable battery can be replaced during operation. Proceed as follows:

Step	Action
1	Insert a screwdriver (DIN 5265, blade width 3.5-6.5 mm) into the right-hand unlock fan opening.
2	Swing the right-hand fan subassembly out (by placing your finger in the round opening on the underside at the front and pulling downwards).  Result: "Fan 3" LED indicates failure of the right-hand fan, and the other two fans operate at increased speed.
3	Slacken the screws on the bottom of the fan subassembly and pull out the rechargeable battery.
4	Disconnect the connecting cable of the rechargeable battery.
5	Connect the cable to the new rechargeable battery.  <b>Important</b> Ensure correct polarity (red terminal on plus, black terminal on minus, see figure "Replacing the rechargeable battery in the fan subassembly").

Step	Action
6	Insert the new rechargeable battery pack in the left-front part of the fan subassembly (plus pole to the right). Ensure that the black connecting cable is lying on the floor of the battery compartment when you insert the battery. Secure it with the screws from below.
7	Insert the fan subassembly with the tab at the rear into the housing and swivel it up until it engages.
8	Press the Reset button.  With a fully discharged battery, the message can only be acknowledged after at least 6 minutes.

*After replacement*

The recharging time for the battery may be up to 46 hours, depending on its state of charge. Please note that backup via the battery is only possible within limits during this time.

If the rechargeable battery does not work after replacement, there may be the following faults:

IF...	THEN ...
"RB low" LED does not go off after 6 minutes,	the rechargeable battery is incorrectly connected or faulty or the charging circuit in the PSU is faulty.
"RB low" LED goes off but the relay does not pick up,	the battery has failed and the yellow "MB low" LED lights up or the battery compartment is faulty.

*Replacing the rechargeable battery in the fan subassembly*

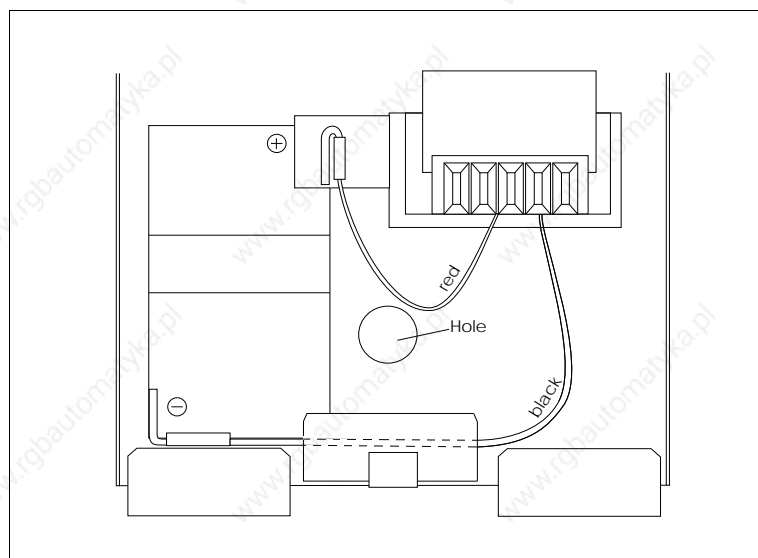

**Replacing the filter mat***Inadequate air flow*

If the filter mat is clogged and the power supply unit no longer receives sufficient air, the "Alarm" LED lights up, LEDs for "Fan 1", "Fan 2" and "Fan 3" flash and the "Alarm" relay picks up. The fault can be cleared by replacing the filter mat (see ordering information for the order number).

*How to replace the filter mat*

Clear the fault in the following steps:

Step	Action
1	Release the filter subdrawer.
2	Swivel the filter subdrawer downwards and pull it forward and out.
3	Remove the old filter mat.
4	Remove residue of the old filter mat from the gripper material.
5	Insert a new filter mat in the filter subdrawer and secure it with the gripper material.
6	Insert the filter subdrawer in the guide rails, slide it back and swivel it up so that it engages.
7	Press the Reset button.  Result: - Fault LEDs for "Alarm", "Fan 1", "Fan 2" and "Fan 3" go off. - Contacts 11 and 12 are closed in the "Alarm" relay.

**Replacing a power supply unit**

If it should be necessary to replace the power supply unit in a system during commissioning or during operation, we recommend you proceed as follows:

**Requirement:**

Redundant backup, "Spare power supply" without rechargeable battery (standard spare part).  
The lithium battery in the rack in in full working order.

Step	Action
1	Disconnect the faulty power supply from the system voltage and remove it.
2	Set the jumpers on the spare power supply according to your needs.
3	Push the spare power supply into the rack and screw it in place.
4	Remove the right-hand fan subassembly from the defective power supply.
5	Remove the rechargeable battery from the fan sub-assembly.
6	Replace the right-hand fan subassembly in the defective power supply.
7	Remove the right-hand fan subassembly from the spare power supply.
8	Connect up the spare power supply.
9	Switch on the system voltage and the power supply in any order.  <b>Reaction:</b> - The system runs up - Both fans run at an increased speed - The LEDs "Fan 3" and "RB low" light up.
10	Insert the rechargeable battery in the fan subassembly and connect it up.
11	Reinsert the right-hand fan subassembly.
12	After the system has run up, press the reset switch on the spare power supply.  <b>Reaction:</b> - The LED "Fan 3" goes out - The fans run at their normal speed again - The LED "RB low" shows the charge state of the rechargeable battery.

**Requirement:**

Redundant backup, "Spare power supply" with rechargeable battery.  
The lithium battery in the rack in in full working order.

Step	Action
1	Disconnect the faulty power supply from the system voltage and remove it.
2	Set the jumpers on the spare power supply according to your needs.
3	Push the spare power supply into the rack and screw it in place.
4	Remove the right-hand fan subassembly from the spare power supply.
5	Connect up the replacement power supply.
6	Switch on the system voltage and the power supply in any order.  <b>Reaction:</b> - The system runs up - Both fans run at an increased speed - The LEDs "Fan 3" and "RB low" light up.
7	Reinsert the right-hand fan subassembly.
8	After the system has run up, press the reset switch on the spare power supply.  <b>Reaction:</b> - The LED "Fan 3" goes out - The fans run at their normal speed again - The LED "RB low" shows the battery charge state.

4

**Requirement:**

No backup

Step	Action
1	Disconnect the faulty power supply from the system voltage and remove it.
2	Set the jumpers on the spare power supply according to your needs.
3	Push the spare power supply into the rack and screw it in place.
4	Connect up the spare power supply.
5	Switch on the system voltage and the power supply in any order.  <b>Reaction:</b> - The system runs up.

#### 4.3.5

#### **Description of Internal Sequences in the Power Supply Unit**

Given in this section is background information on internal sequences in the power supply unit.

#### ***Behavior upon failure of the system supply***

*When the system supply fails*

The behavior of the power supply unit after a system supply failure is governed by the duration of the failure:

<b>IF the system supply failure...</b>	<b>THEN...</b>
lasts up to 20 ms,	the PSU output voltages are within tolerance ranges; no indication appears on the front plate and no signal is sent to the S5 bus.
lasts longer than 20 ms,	a data save routine is initiated on the CPU/CPU's and an output inhibit is issued.

*If the 5 V supply drops below the 4.75 V limit*

If the 5 V supply drops below the lower limit (4.75 V), the power supply also activates the output inhibit, and the data save routine on the CPU is thus initiated.

#### ***Redundant data backup***

Your CC and EU 185 are provided with a lithium battery for data backup, and the power supply unit also contains a rechargeable battery.

In the event of system supply failure or switch-off, data backup is guaranteed by the lithium battery and, in the event of battery failure, by the rechargeable battery which is constantly being charged to its full capacity.

After replacing a defective lithium battery, the new one resumes data backup and on exchanging the battery you should acknowledge the error indication.

As the rechargeable battery is also removed when the power supply unit is replaced, data backup is temporarily performed by the lithium battery.



## Behavior upon failure of fans

### Failure indication

If a fan fails (its speed decreases) a fault is indicated, i.e. the red LED assigned to the fan lights up:

"Fan 1" LED = left fan failed

"Fan 2" LED = middle fan failed

"Fan 3" LED = right fan failed

### If a fan fails

If a fan fails, the following takes place:

Stage	Description
1	A fan fails. Result: - The red LED assigned to the fan lights up.
2	Contacts 9 and 10 in the "Warning" relay are closed.
3	The faulty fan is switched off.
4	The other two fans operate at increased voltage and an audibly higher speed.

4

### If another fan fails

If another fan fails, the following takes place:

Stage	Description
5	Another fan fails. Result: - The red LED assigned to the fan lights up.
6	Contacts 12 and 13 in the "Alarm" relay are closed. Result: - "Alarm" LED lights up. - Two "Fan" red LEDs light up.
7	A data save routine is started and, with the appropriate jumper setting, an output inhibit is issued.
8	The power supply switches off, with the appropriate jumper setting.

### Resetting the fault messages

When the fault has been cleared (faulty fan replaced, filter mat replaced), you can reset the fault messages by pressing the Reset button.



#### Caution

You can suppress the shutdown of the power supply by opening jumper F-R. In this case, you must ensure that the power supply is switched off after 60 secs at the latest. This can be achieved with a time relay, for example. This prevents modules from overheating and becoming destroyed.

### 4.3.6 Technical Specifications of the Power Supply Units

#### Important for the USA and Canada

The following approval has been obtained:



UL Recognition Mark (for USA and Canada)  
Underwriters Laboratories (UL) to  
Standard UL 508, Report E 143289

	6ES5 955-3LC41	6ES5 955-3LF41
<b>Safety Specifications</b>	The power supply units comply with safety specifications VDE 0805 / EN 60950 / IEC 950 / VDE 0160 and VDE 0106.	
Shock protection	only ensured in the installed state.	
Data for EMC in the installed state	see technical specifications of the S5-135U/155U CC	
Safe isolation	is ensured.	
<b>Input</b>		
Rated input voltage	120 V (93-132 V) AC 230 V (187-264 V) AC	120 V (93-132 V) AC 230 V (187-264 V) AC
Rated input frequency	50/60 Hz (47-63 Hz)	50/60 Hz (47-63 Hz)
Input current $I_E$ at rated load and $U_{EN} = 120\text{ V}$ $= 230\text{ V}$	2.5 A <sub>rms</sub> 1.5 A <sub>rms</sub>	4.5 A <sub>rms</sub> 2.6 A <sub>rms</sub>
Peak inrush current $I_{E\max}$	26 A for 100 $\mu\text{s}$ otherwise < 5 A (repetition rate 100 secs)	25 A for 2 ms (repetition rate 100 secs)
$I^2t$ value of inrush current	4 A <sup>2</sup> s	5.2 A <sup>2</sup> s
Efficiency at rated load (with fans) and $U_E \hat{=} 230/120\text{ V AC}$	> 0.63	> 0.68
Max. heat dissipation at rated load at $U_{A1}, U_{A2}, U_{A3}$ (with fans)	80 W	147 W
Efficiency at rated load (without fans) and $U_E \hat{=} 230/120\text{ V AC}$	0.70	0.71
Max. heat dissipation (without fans)	53 W	123 W
Stored energy time during power failure at rated load and $U_E \hat{=} 187/93\text{ V AC}$	> 20 ms	> 20 ms
Input fuse	4 A/slow/250 V, 6.3 x 32 mm, 380A <sup>2</sup> s	8 A/med./250 V 6.3 x 32 mm 200 A <sup>2</sup> s
External battery supply	4.5 V	4.5 V

	6ES5 955-3LC41	6ES5 955-3LF41
<b>Output 1</b>		
Rated output voltage $U_{AN1}$	5.1 V DC $\pm$ 0.5%	5.1 V DC $\pm$ 0.5 %
Rated output current $I_{AN1}$	18 A DC	40 A DC
Basic load	0.5 A	1.6 A typical 3.1 A worst case
Ripple	$\leq$ 1% of $U_{A1}$	$\leq$ 1% of $U_{A1}$
Spikes	$\leq$ 4% of $U_{A1}$	$\leq$ 4% of $U_{A1}$
Static voltage tolerances - at 95 % load variation - at 15 % variation of $U_E$ - at temperature variation / 1K	$\leq$ 0.005% of $U_{A1}$ $\leq$ 0.0005% of $U_{A1}$ $\leq$ 0.02% of $U_{A1}$	$\leq$ 0.08% of $U_{A1}$ $\leq$ 0.0005% of $U_{A1}$ $\leq$ 0.02% of $U_{A1}$
Dynamic voltage tolerances at load surge from 50 % to 100 % $I_{AN}$ - overshoot - settling time	$\leq$ 3% of $U_{A1}$ $\leq$ 5 ms	$\leq$ 3% of $U_{A1}$ $\leq$ 5 ms
<b>Protection and monitoring</b>		
Voltage monitor	Monitors voltage for <14 V and >16 V	Monitors voltage for < 14 V and > 16 V
Oversvoltage shutdown $U_{A1}$	6 V $\pm$ 5%	6 V $\pm$ 5%
Undervoltage signal $U_{A1}$	4.75 V + 3%	4.75 V + 3%
Current limiting for overload	1.0 to 1.2 $I_{AN1}$	1.0 to 1.2 $I_{AN1}$
Test sockets for $I_{A1}$	On front plate (3 V $\hat{=}$ 18 A) linearity range 0.5 V/2.8 A to 3 V/18 A	On front plate (3 V $\hat{=}$ 40 A) linearity range 0.5 V/6.6 A to 3 V/40 A
Signalling section	Signals for SIMATIC S5, relays: "Fan Warning, Fan Alarm, Warning" 250 V/3 A	Signals for SIMATIC S5, relays: "Fan Warning, Fan Alarm, Warning" 250 V/3 A
Green LED: "5 V o.k." for $U_{A1}$	LED lights up if 4.75 V < $U_{A1}$	LED lights up if 4.75 V < $U_{A1}$
<b>Output 2</b>		
Rated output voltage $U_{AN2}$	24 V DC (+ 25%, -12,5%)	24 V DC (+ 25%, -12.5%)
Rated output current $I_{AN2}$	1 A DC	2.8 A DC
Total current X2 and front terminals	1 A max.	2.8 A max.
Ripple	$\leq$ 1% of $U_{A2}$	$\leq$ 1% of $U_{A2}$
Spikes	$\leq$ 2% of $U_{A2}$	$\leq$ 2% of $U_{A2}$
<b>Protection and monitoring</b>		
Current limiting for overload	1 to 1.3 $I_{AN2}$	1 to 1.3 $I_{AN2}$
Green LED "24 V o.k." for $U_{A2}$	LED lights up if $U_{A2}$ > 19.9 V to 21.1 V	LED lights up if $U_{A2}$ > 19.9 V to 21.1 V
<b>Output 3</b>		
Rated output voltage $U_{AN3}$	15 V DC ( $\pm$ 5 %)	15 V DC ( $\pm$ 5 %)
Rated output current $I_{AN3}$	0.5 A DC	2 A DC
Ripple	$\leq$ 1 % of $U_{A3}$	$\leq$ 1 % of $U_{A3}$

## Power Supply Units

	<b>6ES5 955-3LC41</b>	<b>6ES5 955-3LF41</b>
Spikes	$\leq 3\%$ of $U_{A2}$	$\leq 3\%$ of $U_{A2}$
<b>Protection and monitoring</b>		
Overvoltage shutdown $U_{A3}$	$17\text{ V} \pm 5\%$	$17\text{ V} \pm 5\%$
Current limiting for overload	1 to $1.5 I_{AN3}$	1 to $1.5 I_{AN3}$
Green LED 15 V o.k. for $U_{A3}$	LED lights up if $14.2\text{ to }14.7\text{ V} < U_{A3} < 16.1$ to $17.9\text{ V}$	LED lights up if $14.2\text{ to }14.7\text{ V} < U_{A3} < 16.1$ to $17.9\text{ V}$
<b>Backup battery</b>		
Type	Lithium thionyl chloride	
Capacity	5 Ah	
No-load voltage	3.6 V	
Voltage under load	3.4 V	
Storage life	approx. 10 years	
Service life in operation (see Section 4.3.4 for backup times)	3 years max.	
<b>Rechargeable battery</b>		
Type	Nickel cadmium	
Capacity	1.2 Ah	
Rated voltage	3.6 V	
Service life in operation (see Section 4.3.4 for backup times)	6 years at $40\text{ }^{\circ}\text{C}$ ( $104\text{ }^{\circ}\text{F}$ )	
<b>Service life of fans</b>	approx. 50,000 h at $40\text{ }^{\circ}\text{C}$	approx. 50,000 h at $40\text{ }^{\circ}\text{C}$
<b>Weight</b>	approx. 5.8 kg	approx. 5.8 kg
<b>Noise emission</b>	58 dBA	58 dBA
<b>Environmental data</b>	See technical specifications of the S5-135U/155U CC	

	<b>6ES5 955-3NC41</b>	<b>6ES5 955-3NF41</b>
<b>Safety Specifications</b>	The power supply units comply with safety specifications VDE 0805 / EN 60950 / IEC 950 / VDE 0160 and VDE 0106 part 101.	
Shock protection	only ensured in the installed state.	
Data for EMC in the installed state	See technical specifications of the S5-135U/155U CC	
Safe electrical separation	is ensured. <sup>1)</sup>	
<b>Input</b>		
Rated input voltage	24 V DC (18-33 V)	24 V DC (18-33 V)
Input current $I_E$ at rated load and $U_{EN} = 24 V$	9.5 A	20 A
Peak inrush current $I_{E_{max}}$	100 A for 100 $\mu s$	200 A for 1 ms
$I^2t$ value of inrush current	2.7 A <sup>2</sup> s	18 A <sup>2</sup> s
Efficiency at rated load (with fans) and $U_E \hat{=} 24V$	0.6	0.67
Max. heat dissipation at rated load (with fans) at $U_{A1}, U_{A2}, U_{A3}$	90 W	153 W
Efficiency at rated load (without fans) and $U_E \hat{=} 230/120 V AC$	0.65	0.7
Max. heat dissipation (without fans)	66 W	129 W
Stored energy time during power failure at rated load and $U_E \hat{=} 18 V DC$	>20 ms	>20 ms
Input fuse	20 A /super-fast/32 V, 6.3 x 32 mm	30 A /super-fast/65 V, 6.3 x 32 mm
External battery supply	4.5 V	4.5 V
<b>Output 1</b>		
Rated output voltage $U_{AN1}$	5.1 V DC $\pm 0.5 \%$	5.1 V DC $\pm 0.5 \%$
Rated output current $I_{AN1}$	18 A DC	40 A DC
Basic load	0.5 A	1.6 A typical 3.1 A worst case
Ripple	$\leq 1\%$ of $U_{A1}$	$\leq 1\%$ of $U_{A1}$
Spikes	$\leq 4\%$ of $U_{A1}$	$\leq 4\%$ of $U_{A1}$
Static voltage tolerances - at 95 % load variation - at 15 % variation of $U_E$ - at temperature variation / 1K	$\leq 0.08\%$ of $U_{A1}$ $\leq 0.0005\%$ of $U_{A1}$ $\leq 0.02\%$ of $U_{A1}$	$\leq 0.08\%$ of $U_{A1}$ $\leq 0.0005\%$ of $U_{A1}$ $\leq 0.02\%$ of $U_{A1}$
Dynamic voltage tolerances at load surge from 50 % to 100 % $I_{AN}$ - overshoot - settling time	$\leq 3\%$ of $U_{A1}$ $\leq 5 ms$	$\leq 3\%$ of $U_{A1}$ $\leq 5 ms$

1) These power supply units are isolated between the input circuit (24 V DC) and the secondary circuit, which fulfils the requirements for 230 V AC.

	6ES5 955-3NC41	6ES5 955-3NF41
<b>Protection and monitoring</b>		
Voltage monitor	Monitors voltage for <14V and >16V	Monitors voltage for < 14V and > 16V
Overtoltage shutdown $U_{A1}$	$6V \pm 5\%$	$6V \pm 5\%$
Undervoltage signal $U_{A1}$	$4.75V + 3\%$	$4.75V + 3\%$
Current limiting for overload	1.0 to 1.2 $I_{AN1}$	1.0 to 1.2 $I_{AN1}$
Test sockets for $I_{A1}$ on front plate	$(3V \hat{=} 18A)$	$(3V \hat{=} 40A)$
Signalling section	Signals for SIMATIC S5, relays: "Fan Warning, Fan Alarm, Warning" 250V/3A	Signals for SIMATIC S5, relays: "Fan Warning, Fan Alarm, Warning" 250V/3A
Green LED: "5 V o.k." for $U_{A1}$	LED lights up if $4.75V < U_{A1}$	LED lights up if $4.75V < U_{A1}$
<b>Output 2</b>		
Rated output voltage $U_{AN2}$	24 V DC (+25 %, -12.5 %)	24 V DC (+ 25%, -12.5%)
Rated output current $I_{AN2}$	1 A DC	2.8 A DC
Total current X2 and front terminals	1 A max.	2.8 A max.
Ripple	$\leq 1\%$ of $U_{A2}$	$\leq 1\%$ of $U_{A2}$
Spikes	$\leq 2\%$ of $U_{A2}$	$\leq 2\%$ of $U_{A2}$
<b>Protection and monitoring</b>		
Current limiting for overload	1 to 1.3 $I_{AN2}$	1 to 1.3 $I_{AN2}$
Green LED "24V o.k." for $U_{A2}$	LED lights up if $U_{A2} > 19.9V$ to 21.1 V	LED lights up if $U_{A2} > 19.9V$ to 21.1 V
<b>Output 3</b>		
Rated output voltage $U_{AN3}$	15 V DC ( $\pm 5\%$ )	15 V DC ( $\pm 5\%$ )
Rated output current $I_{AN3}$	0.5 A DC	2 A DC
Ripple	$\leq 1\%$ of $U_{A3}$	$\leq 1\%$ of $U_{A3}$
Spikes	$\leq 3\%$ of $U_{A2}$	$\leq 3\%$ of $U_{A2}$
<b>Protection and monitoring</b>		
Overtoltage shutdown $U_{A1}$	$17V \pm 5\%$	$17V \pm 5\%$
Current limiting for overload	1 to 1.5 $I_{AN3}$	1 to 1.5 $I_{AN3}$
Green LED "15V o.k." for $U_{A3}$	LED lights up if $14.2$ to $14.7V < U_{A3} < 16.1$ to $17.9V$	LED lights up if $14.2$ to $14.7V < U_{A3} < 16.1$ to $17.9V$

	6ES5 955-3NC41	6ES5 955-3NF41
<b>Backup battery</b>		
Type	Lithium thionyl chloride	
Capacity	5 Ah	
No-load voltage	3.6 V	
Voltage under load	3.4 V	
Storage life	approx. 10 years	
Service life in operation (see Section 4.3.4 for backup times)	3 years max.	
<b>Rechargeable battery</b>		
Type	Nickel cadmium	
Capacity	1.2 Ah	
Rated voltage	3.6 V	
Service life in operation (see Section 4.3.4 for backup times)	6 years at 40 °C (104 °F)	
<b>Service life of fans</b>	approx. 50,000 h at 40 °C	approx. 50,000 h at 40 °C
<b>Weight</b>	approx. 5.8 kg	approx. 5.8 kg
<b>Noise emission</b>	58 dBA	58 dBA
<b>Environmental data</b>	See technical specifications of the S5-135U/155U CC	

## 4.4 24 V/4 A Load Power Supply

### 4.4.1

#### Technical Description

This section provides information on the application, design and principle of operation of the SIMATIC S5 951 load power supply module (6ES5-951-4LB11).

#### Application

The load power supply module can be used with a choice of input voltage of 120 V or 230 V AC. It supplies a floating, electronically stabilized output voltage of 24 V, and can be used with SIMATIC S5 systems to supply power for load circuits and enable inputs of modules of the U Periphery.

The load power supply module has safe electrical separation to VDE 0160.

#### Design

The module is designed in the double Eurocard format for the ES 902 packaging system.

A 20-pin front connector contains all the terminals for the supply voltage, DC voltage outputs, signalling output and inhibit inputs.

The module is two slots wide (40 mm).



*Front plate and side view*

Shown in the following figure are the front plate and side view of the load power supply:

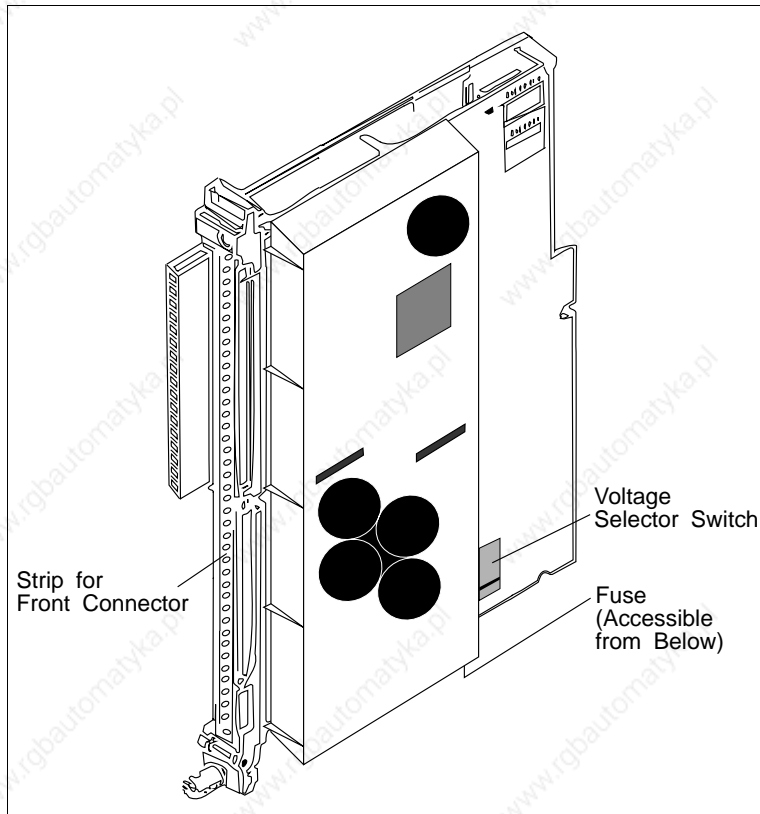

The inputs/outputs and indicators are on the front plate of the load power supply.

**Outputs**

The outputs of the load power supply are given in the following table:

Outputs	Ratings	Description
Continuous short-circuit protected power output (1L+)	4 A	For resistive and inductive load
4 outputs (2L+ to 5L+)	0.5 A each	For resistive load (max. capacitive load 50nF)

**Inputs**

Inputs of the load power supply are given in the following table:

Inputs	Current Inputs	Description
L1 N PE	120V/240V, 50Hz	Phase Neutral conductor Protective conductor
4 inhibit inputs (2L+ to 5L+)	2.5 mA	Outputs 2L+ to 5L+ can be switched off individually with a logic low at these inputs.

**4****Indicators**

Given in the following table are the indicators of the load power supply and their significance:

Indicators	Significance
5 green LEDs	Outputs 1L+ to 5L+ are operating correctly
1 red LED	Short-circuit at outputs 2L+ to 5L+

**Controls**

The voltage selector switch is on the basic module and is set to 230 V when delivered (see switch labelling).

**Front connector**

Signal lines for the load power supply module must be connected via a front connector. The front connector is not supplied with the power supply module and must be ordered separately. You have a choice of crimp connections and screw connections. The order numbers can be found in the ordering information.

The front connector hooks into the lower end of the module; it should be swivelled up and screwed to the module.

Front strip

Shown in the following figure are the terminal assignments of the front strip:

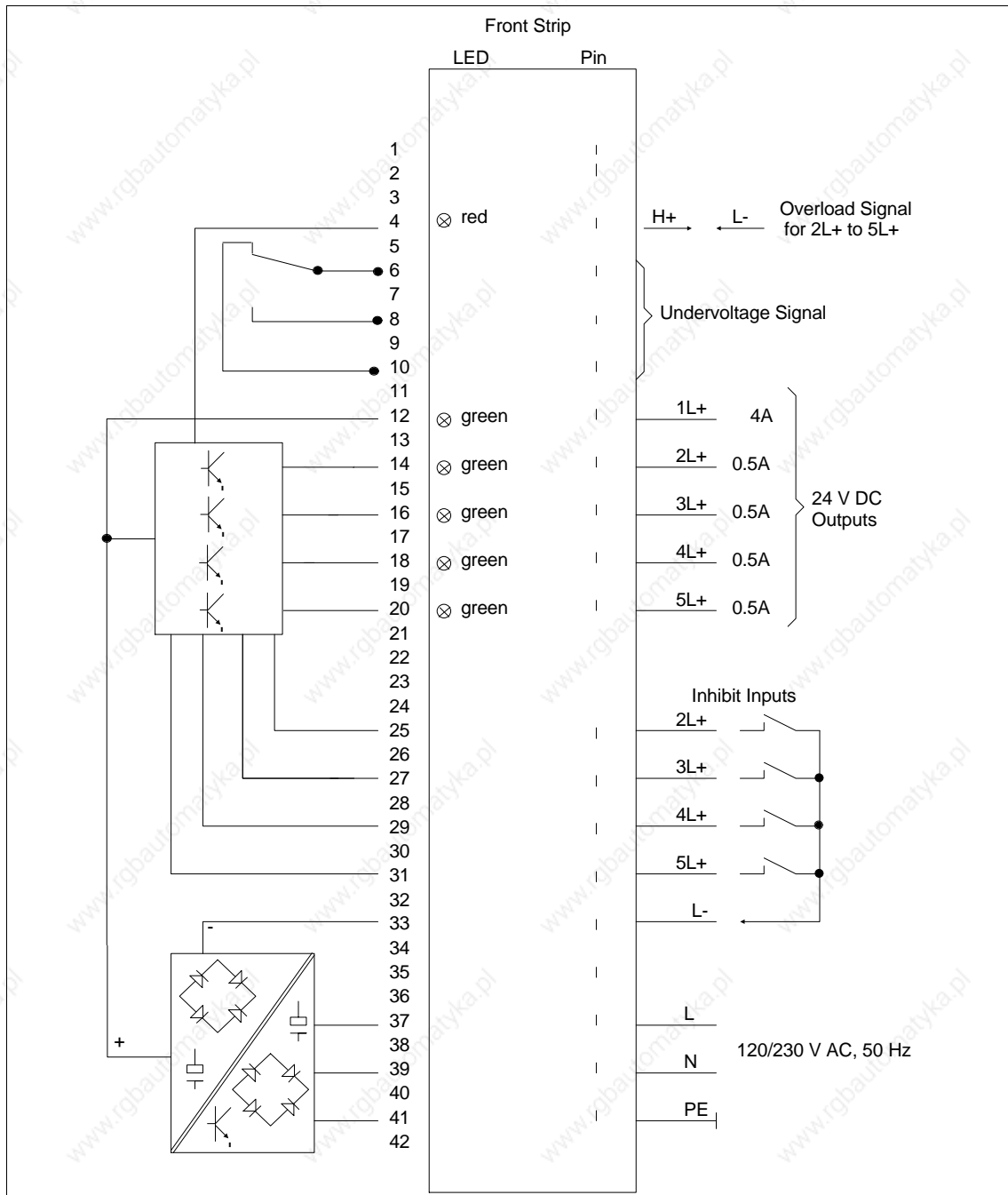

#### 4.4.2 Startup

This section provides information on setting the AC voltage and connecting the unit to AC power.

##### **Setting the AC voltage**

When delivered, the module is set to an AC voltage of 230 V AC.

The visible labelling of the voltage selector switch must agree with the AC supply at the site.

##### **Note**

For 120 V AC a 2 A (slow) fuse must be used.

**4**

##### **Connecting the AC leads**

The following must be provided when connecting the AC leads to a stationary installation:

- A protective device (fuse or circuit breaker)
- and an isolating device to isolate the module.

AC leads must be connected according to VDE 0100 and VDE 0160.

#### 4.4.3 Fault Indications/ Fault Diagnostics

Load power supply faults are indicated by LEDs on the front plate:

IF...	THEN...	AND...
the red LED lights up and signalling output H+ is at logic 1,	there is a short-circuit (overload) at outputs 2L+ to 5L+	the outputs will be switched off. When the short-circuit has been corrected, 2L+ to 5L+ will return automatically to normal operation.
the module switches off (all LEDs off),	output 1L+ was overloaded with a current of more than 5.5 A for a few seconds	when the overload has been removed, the AC supply must be briefly switched off and on again.

#### 4.4.4 Technical Specifications

##### Important for the USA and Canada

The following approvals have been obtained:



UL Listing Mark  
Underwriters Laboratories (UL) to  
Standard UL 508, Report E 85972



CSA Certification Mark  
Canadian Standard Association (CSA) to  
Standard C 22.2 No. 142, Report LR 63533

4

Safety specifications	The power supply unit complies with standard VDE 0160.
Input voltage - Rated value - Permissible range at 230 V AC at 120 V AC	230/120 V AC 187 to 253 V AC 93 to 127 V AC
Rated frequency - Rated value - Permissible range	50 Hz 47 to 63 Hz
AC fuse - at 230 V AC - at 120 V AC	1 A, slow 2 A, slow
Isolation	Yes
Input current - Rated value at 230 V AC at 120 V AC	0.85 A 1.55 A
Inrush current - at 230 V AC - at 120 V AC	10 A 5 A
Output voltage - Rated value - Tolerance	24 V $\pm 2$ V
Maximum output current - Output 1L+ - Outputs 1L+ to 5L+	4 A 0.5 A each (resistive load only; max. capacitive load 50 nF)
Total current for output	1L+ to 5L+, 4 A max.
Overload signal output for outputs 2L+ to 5L+	24 V/10 mA, with current limiting
Contact rating of relay (undervoltage signal)	3 A/250 V AC max.
Inhibit inputs for outputs 2L+ to 5L+	2.5 mA current input
RFI suppression to VDE 0871 in the range 10 kHz to 30 MHz	Limit class A

Operating temperature (supply air temperature under the subrack) - For units with fan - For units without fan (Clearance from PCBs: 40 mm)	0 to 60 °C 0 to 55 °C
Insulation voltage to VDE 0160 - Between AC supply and protective conductor/housing - Between outputs and protective conductor/housing	1500 V AC 500 V AC

## 4.5 6ES5 955-3NA12 Power Supply Unit

Your 135U central controller (6ES5 135-3UA41) contains the following power supply unit (PSU):

Type of PSU Designation	Input Voltage	Output Voltage
6ES5 955-3NA12 (primary/secondary, non-floating)	24 V DC	5 V/10 A DC permissible range 0 to 10 A 24 V/0.8 A DC 24V/0.8 A DC permissible range 0 to 0.8 A

4

### 4.5.1 Technical Description

The power supply unit offers the following functions:

- **System power supply**  
All system voltages needed to operate the CC are supplied. The 15 V supply needed to operate the SINEC H1 system can be incorporated in the power supply unit by fitting an auxiliary submodule.
- **Voltage supply for backup**  
A lithium battery ensures data backup when power is switched off or fails.
- **Heat dissipation**  
The power dissipation is removed by fans.



**Indicators and controls**

The following indicators and controls are arranged on the front plate:

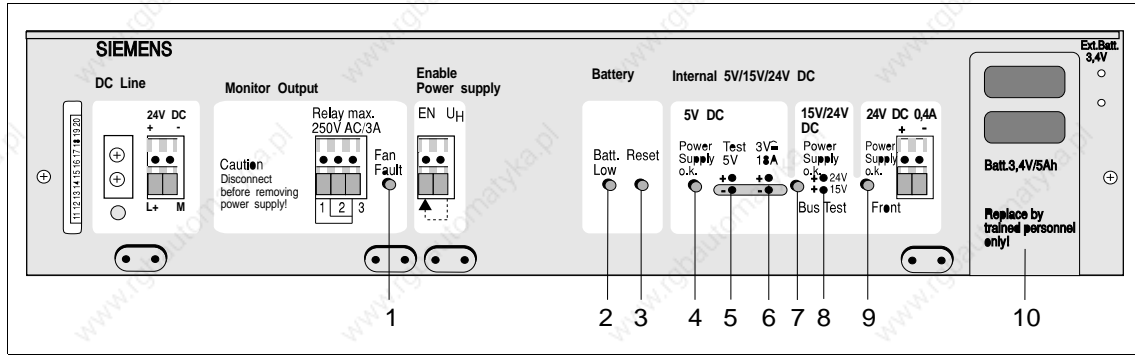

ID	Label	Element	Purpose
1	Fan Fault	Red LED	The LED lights up to indicate a fan fault. The PSU then switches off (jumper F-R closed). If, for technical reasons, you cannot immediately switch off the PLC, you must open jumper F-R. However, switch off the PLC after 60 s at the latest (overheating of modules).
2	Batt. Low	Yellow LED	The LED lights up if the battery voltage has dropped below 2.7 V; the data stored in the RAM may be lost after "Power OFF/ON".
3	Reset	Button	If the PLC is in the "Power OFF" state, the battery must be replaced after "Power ON" when the "Batt. Low" LED is lit. You must press the Reset button after changing the battery.
4	Power Supply o.k.	Green LED	The LED lights up when the 5 V output voltage is present.
5	Test 5 V	Test socket	To measure output voltage $U_{A1}$ (standard setting: 5.1 V DC $\pm$ 0.5%)
6	3 V $\hat{=}$ 10 A	Test socket	To measure output $I_{A1}$ (3 V = max. output current of the PSU), linearity range 0.5 V/1.6 A to 3 V/40 A
7	Power Supply o.k. (Bus)	Green LED	The LED lights up to indicate presence of the 15 V output voltage (if the 15 V auxiliary submodule is fitted) and 24 V output voltage
8	DC 15V/24V (Bus)	Test sockets	a) To measure output voltage $U_{A2}$ (24 V DC $\pm$ 25 %/-24 %) b) To measure output voltage $U_{A3}$ (15 V DC $\pm$ 5 %, provided that 15 V aux. submodule is fitted)
9	Power Supply o.k. (terminal)	LED	The green LED lights up to indicate presence of the output voltage at the "DC 24 V" terminal for the enable supply.
10	Batt. 3.4V/5Ah	Battery drawer	The backup battery is arranged so that it can be replaced during operation and the PSU can be replaced during battery backup without the backup voltage being interrupted.

## Terminals

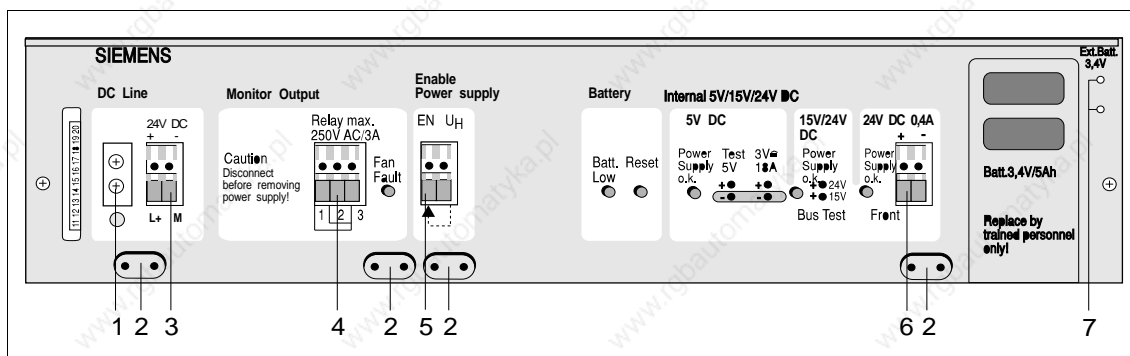

ID	Label	Element	Purpose
1			Protective conductor terminal for PSU module and housing.
2			Strain reliefs for connecting cables, with metal contact surface for cable shields.
3	DC Line	Screw terminals	System connection, 24 V input voltage
4	Monitor Output	Relay output	Standstill of one or both fans is signalled via LED and relay contact to the exterior, and results in shutdown of output voltages (can be shut down via jumper F-R of the PSU; then only relay signal and LED indication).
5	Enable Power supply	Input/output	No voltage at the EN input results in shutdown of the PSU. Not more than 7 EN inputs may be driven with one U <sub>H</sub> output (front terminal).
6	DC 24 V; 0.4 A	Output	This output can be used to power the enable inputs of the U Periphery.
7	Ext.Batt. 3.4 V	Sockets	Sockets for external 3.4 V backup voltage.



### Caution

Observe the appropriate VDE specifications, especially VDE 0100. The terminals at the front are suitable for a conductor cross-section of up to 4 mm<sup>2</sup>, solid, or 2.5 mm<sup>2</sup>, flexible. Ensure adequate strain relief of the connections.

### 15 V auxiliary submodule

You can add a 15 V auxiliary submodule to the 6ES5 955-3NA12 power supply unit (e.g. if you wish to use SINEC H1). The auxiliary submodule produces a stabilized 15 V output voltage from the 24 V output voltage. The auxiliary submodule is short-circuit protected. The output voltage is monitored. If the voltage is too low, the green "15/24 V o.k." LED on the front plate goes off. If the voltage is too high, the output is short-circuited by a thyristor.

### 4.5.2 Setting the Power Supply Unit

#### Locations of jumpers

The figure shows the jumper settings when the unit is delivered.

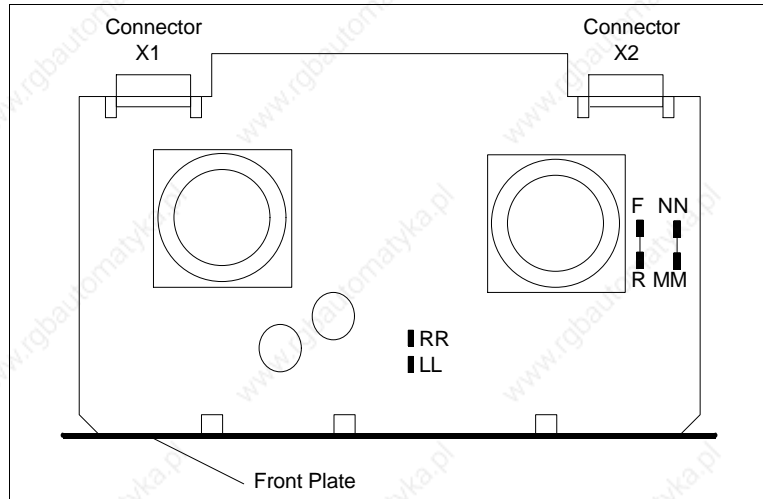

#### Functions of the jumpers

The jumper settings in bold print indicate the status when the unit is delivered.

Function	Jumpers
Battery monitor (BAU) On	<b>NN-MM closed</b>
Battery monitor (BAU) Off	NN-MM open
PSU shutdown after fan fault	<b>F-R closed</b>
No PSU shutdown after fan fault (only LED indication, relay signal)	F-R open
Battery fault will be indicated by fault state of the signalling relay (contacts 2-3 closed).  Battery undervoltage (< 2.7 V) results in battery fault signal (jumper MM-NN). Apart from "Batt. Low" LED and output of signal BAU, the signalling relay can be activated as of Version 6 of the PSU.	RR-LL closed
Battery fault will not be indicated by fault state of the signalling relay.	<b>RR-LL open</b>

**Setting the fan monitor**

You can set jumper F-R on the power supply units to choose whether or not the air flow monitor should switch off the internal supply voltage  $U_A$  (5 V) when a fan fails.

- Jumper F-R closed:  $U_A$  shutdown (signalled by contact)
- Jumper F-R open: no  $U_A$  shutdown (signalled by contact)

If one or both fans are at standstill, the signalling relay drops out (monitor output). The "Fan Fault" LED lights up simultaneously.

- Relay contacts 2-1 closed: fan running
- Relay contacts 2-3 closed: fan failure

Relay contacts 2-3 closed; this is also the normally closed contact during power OFF (failsafe).

**Caution**

If an immediate shutdown is not possible, jumper F-R must be opened. In this case you must ensure that the power supply is switched off after 60 s at the latest. This can be achieved with a time relay, for example. It avoids overheating and destruction of modules.

### **Setting the backup battery monitor**

As of Version 6 of PSU 6ES5 955-3NA12, you can set jumper RR-LL to choose whether the signalling relay (monitor output) should switch in the event of battery failure as well as fan failure:

- Jumper RR-LL open (state when delivered): relay will signal only a fan failure
- Jumper RR-LL closed: relay will signal a fan and battery failure.

If the backup voltage fails or a fan is at standstill, or in both cases, the signalling relay will drop out (monitor output). The "Batt. Low" LED will also light up.

- Relay contacts 2-1 closed: battery backup voltage in order and fan running
- Relay contacts 2-3 closed: backup voltage under 2.7 V or fan failure

#### **Note**

The signalling relay in the power supply unit will drop out in the event of a fan fault or backup battery fault. The user's circuitry for the signalling relay must therefore be suitable for both types of fault.

If the signalling relay drops out because of a backup battery fault and the programmable controller is therefore switched off, the program in the main memory may be lost. Loss of program can be avoided if an external backup voltage (3.4 V) is present at the sockets on the front plate of the power supply unit during shutdown of the programmable controller.

### 4.5.3 Installation

To install the power supply unit, push it into the rack. Press it in firmly until the front plate is at the rack. The spring pressure of the contact elements must be overcome. Then tighten the two screws to the left and right of the front plate in the rack. The protective conductor jumper on the left must be permanently connected to the front plate terminal and the central rack.

#### Caution

Power supply units may only be removed when no power is applied.

4

When the power supply unit is pulled out, the connection between backup battery and backplane bus is retained; the backup supply for the modules is thus ensured.

### Installing the 15 V auxiliary submodule

The auxiliary submodule (see ordering information for order number) may only be inserted when the power is off. Remove the power supply unit, fit the 15 V auxiliary submodule at the location shown in the following figure.

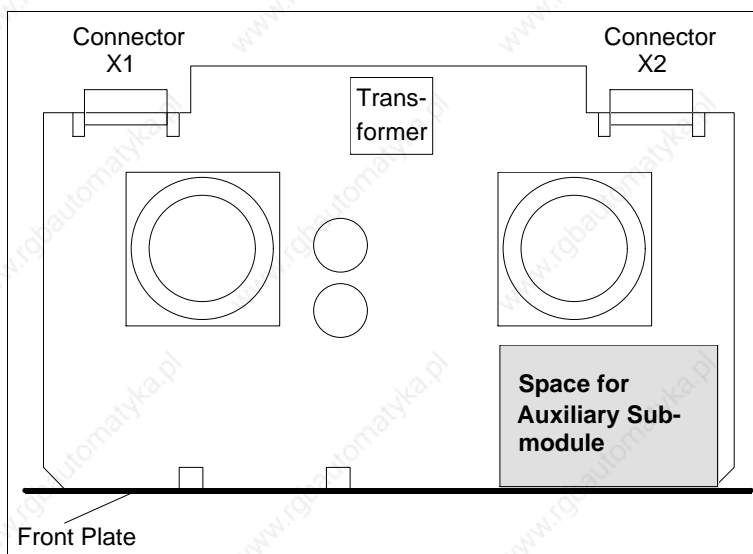

#### 4.5.4 Operation

Before placing the power supply unit in operation, please comply with the notes in the following section.

##### **General notes on the power supply unit**

- No voltage of more than 50 V may develop between the power supply outputs and the protective conductor of the power supply unit.
- The protective conductor must always be connected, as must the jumper between CC rack and front plate of the power supply unit.
- In the event of overvoltage of the internal DC supply voltages  $U_{A1} = +5\text{ V}$  and  $U_{A3} = +15\text{ V}$ , the power supply unit is switched off retentively. There is a voltage of  $\leq 0.5\text{ V}$  at  $U_{A1}$  and  $U_{A3}$  in the Off state (see Section 4.5.6, Technical Specifications, for overvoltage shutdown).  
The storage flip-flop is reset by switching the external supply voltage off and on again, and the power supply unit is again operational if the overvoltage was not the result of an internal fault.
- You can insert an air filter with filter holder in the bottom of the housing of the power supply unit.
- Observe the voltage level of 3.4 V and correct polarity when applying an external backup voltage.
- The backup battery is supplied separately and must be fitted before startup. Without a backup battery, the programmable controller will remain in the Stop state when system voltage has been switched on. The backup battery must be fitted for startup. Press the RESET button, then carry out an OVERALL RESET.
- The jumper from terminals  $U_H$  to EN will enable the power supply. You can lock out the PLC in the event of a fault by means of suitable circuitry between the monitoring outputs and the EN inputs.

**Fault indications/  
diagnostics**

Power supply faults are indicated via relay contacts and LEDs.

The following table shows when the relay contacts are open or closed:

Power Supply	Relay Contacts 1-2	Relay Contacts 2-3
Switched off	Open	Closed
In normal operation	Closed	Open
During fault	Open	Closed

The LEDs indicate the following faults:

LED	Cause	Action
"Fan Fault" LED lights up.	A fan fault has occurred.	Replace fan
"Batt. low" LED lights up.	The battery voltage has dropped below 2.7 V.	Replace backup battery



**4.5.5  
Maintenance**

**Replacing the backup  
battery**



**Caution**

Incorrect replacement of the battery can result in explosion hazard. It should only be replaced by the same type or an equivalent type recommended by the manufacturer. Used batteries should be disposed of according to the manufacturer's instructions.

You can replace the backup battery without loss of data if the power supply unit is switched on, or if you apply an external voltage (3.4 V) at the "Ext. Batt." sockets. The backup battery must be replaced every 3 years at the latest, irrespective of memory configuration and backup operation. Replace the battery as follows:

Step	Action
1	Pull the cover downwards.
2	Pull the battery submodule forwards and out, and remove it.
3	Replace the battery.
4	Ensure correct polarity.
5	Once the new battery is fitted and system voltage is On, press the Reset button on the power supply unit.

**Battery submodule**

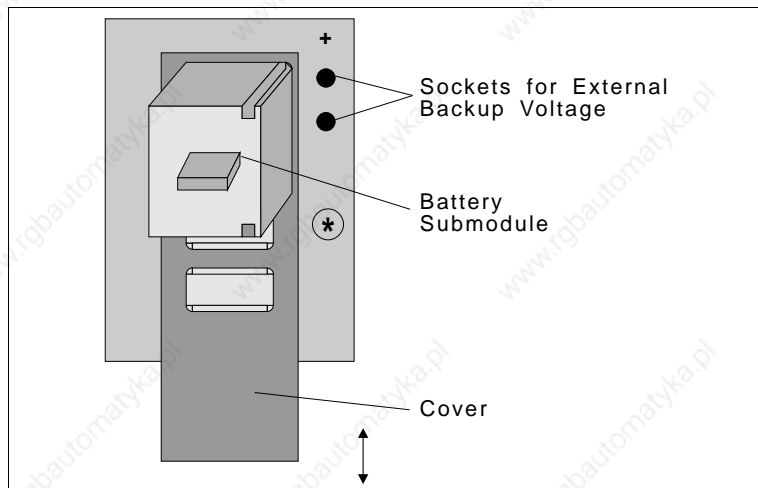

Only use battery submodules of order number 6XG3 400-2CK00!

**Caution**

Ensure correct polarity when inserting the battery or applying backup voltage!

**Caution: LITHIUM THIONYL CHLORIDE BATTERY!**

Do not discard a new or discharged battery in a fire and do not solder on the cell body (max. temperature 100 °C (212 °F)). Do not recharge, there is a risk of explosion. Do not open the battery, only replace it by the same type. Procure the replacement from Siemens; see the ordering information for order number. This ensures that you have a short-circuit protected type. Old batteries with a residual charge should be discharged by means of a 10 ohm resistor or flashlight bulb until there is no longer a measurable no-load voltage.

Lithium thionyl chloride batteries without residual charge should be sent for recycling.

4

**Replacing the fans**

The expected service life of the fans (see Technical Specifications) depends on their operating time, ambient temperature and ambient conditions. In the event of fan failure during operation, subsequent damage to modules, for example, is avoided by the activated fan monitor (jumper F-R closed); the power supply unit is switched off. In individual cases, a preventive replacement of fans at suitable intervals may be advisable.

Proceed as follows to replace the fans:

Step	Action
1	Disconnect power from the power supply.
2	Remove the power supply.
3	Slacken the fixing screws of the fans.
4	Pull off the plug-in contacts of the fan supply.
5	Connect the plug-in contacts of the new fans.
6	Tighten the fixing screws of the fans.
7	Refit the power supply.
8	Switch the power supply on.

The order numbers for the backup battery and fan unit can be found in the ordering information.

#### 4.5.6 Technical Specifications

##### Important for the USA and Canada

The following approvals have been obtained:



UL Recognition Mark

Underwriters Laboratories (UL) to  
Standard UL 508, Report E 116536



CSA Certification Mark

Canadian Standard Association (CSA) to  
Standard C 22.2 No. 142, Report LR 63534

Safety specifications	The power supply unit complies with standard VDE 0160.
<b>Input</b>	
Rated input voltage $U_{EN}$	24 V DC $\pm 25\%$ / $-16.66\%$
Undervoltage signal $U_E$	$\leq 20$ V DC
Input current $I_{EN}$ at rated load and $U_{EN} = 24$ V DC	4.8 A DC
Inrush current peak $I_{Emax}$	100 A
$I^2t$ -value of inrush current	20 A <sup>2</sup> s
Efficiency at rated load and $U_{EN} = 20$ V without fan with fan	0.71 typical 0.60 typical
Stored energy time for power failure	$> 5$ ms
Input fuse	6 A fast, 250 V, 6.3 x 32 mm
<b>Output 1</b>	
Rated output voltage $U_{A1}$	5.1 V DC $\pm 0.5\%$
Rated output current $I_{A1}$	10 A DC
Ripple	$\leq 1\%$ of $U_{A1}$
Static voltage tolerances at 10 % load variation at 5 % variation of $U_E$ at temperature variation/1K	$\leq 0.02\%$ of $U_{A1}$ $\leq 0.04\%$ of $U_{A1}$ $\leq 0.02\%$ of $U_{A1}$
Dynamic voltage tolerances at load surge from 50 % to 100 % overshoot settling time	$\leq 5\%$ of $U_{A1}$ $\leq 5$ ms
Protection and monitoring Overvoltage shutdown $U_{A1}$ Undervoltage signal $U_{A1}$ Current limiting for overload	6 V $\pm 5\%$ 4.75 V + 5% 1.05 to 1.15 $I_{A1}$
Test sockets for $U_{A1}$ $I_{A1}$	On front plate On front plate (3 V $\hat{=}$ 10 A) Linearity range 0.5 V/1.6 A to 3 V/10 A
Signalling section	Signals for SIMATIC S5

<b>Output 2 (bus)</b>	
Rated output voltage $U_{AN2}$	24 V DC +25 %/-20 %
Rated output current $I_{AN2}$	0.8 A DC
Total current rating 24 V/15 V output	$\leq 0.8$ A
Ripple	Input voltage ripple
Protection and monitoring Fuse for overcurrent protection Test sockets for $U_{A2}$ - green LED 15 V/24 V o.k. for $U_{A2}$ (fuse monitor)	1.5 A fast, 250 V, 6.3 x 32 mm on front plate (24 V test) The LED lights up wenn $U_{A2} > 17.9$ to 18.5 V
<b>Output 2 (front)</b>	
Rated output voltage $U_{AN4}$	24 V DC +25 %/-24 %
Rated output current $I_{AN4}$	0.4 A DC
Capacitive load	$< 100$ nF
Protection and monitoring Overcurrent protection by current limiting $I_{A4}$ Test sockets for $U_{A2}$ - green LED 24 V o.k. for $U_{A4}$	$> 0.44$ A on front plate (24 V test) The LED lights up when $U_{A4} > 16$ V +/-20 %
Total current rating of 24 V voltages (bus and front)	must not exceed 0.8 A
<b>Output 3 with 15 V auxiliary submodule</b>	
Rated output voltage $U_{AN3}$	15 V DC +/-5 %
Rated output current $I_{AN3}$	0.5 A DC
Ripple	$\leq 5$ % of $U_{AN3}$
Protection and Monitoring Overvoltage protection (output is short-circuited at $U_{A3}$ ) Undervoltage signal (LED 15 V/24 V o.k. on front plate goes off at) Overcurrent protection $I_{A3}$ by current limiting  Test socket for $U_{A3}$	$\geq 18.5$ V  $\leq 14$ V $\pm 3$ % $> 0.5$ to 1.5 A  on front plate (15 V test)
<b>Fans</b>	
Fan type	2 axial fans
Input voltage	24 V DC
Flow rate per fan	160 m <sup>3</sup> /h (no-load value)
Fan monitoring	Air flow monitoring with PTC thermistors as sensors; stoppage of one or both fans is detected and signalled to the exterior via Fan Fault LED and relay contacts, and results in shutdown of output voltage (switched off via jumper F-R).
Expected service life of a fan	30,000 to 40,000 h typical at 55 °C 40,000 to 50,000 h typical at 30 °C

## 6ES5 955-3NA12 Power Supply Unit

---

<b>Isolation</b> primary/secondary and test voltages	No
<b>Weight</b>	3.75 kg
<b>Environmental data</b>	See Technical Specifications of the S5-135U/155U CC
RFI suppression	DIN VDE 0871, A

# 5

## CPUs, Memory Cards, Memory Submodules, Interface Submodules

### Contents of Chapter 5

5	CPUs, Memory Cards, Memory Submodules, Interface Submodules . . . . .	5 - 5
5.1	CPU 948 . . . . .	5 - 6
5.1.1	Technical Description . . . . .	5 - 6
	Application . . . . .	5 - 6
	Design . . . . .	5 - 7
5.1.2	Installation and Startup . . . . .	5 - 8
	Jumper settings . . . . .	5 - 8
	Removing and inserting the module . . . . .	5 - 9
	Controls and indicators . . . . .	5 - 10
	Startup . . . . .	5 - 15
5.1.3	Interfaces of the CPU 948 . . . . .	5 - 17
5.1.4	Technical Specifications . . . . .	5 - 18
5.2	CPU 928B . . . . .	5 - 21
5.2.1	Technical Description . . . . .	5 - 21
	Application . . . . .	5 - 21
	Design . . . . .	5 - 21
	User memory . . . . .	5 - 22
	PG Interface SI1 . . . . .	5 - 22
	Second interface SI2 . . . . .	5 - 23
	Process interrupt processing . . . . .	5 - 24
5.2.2	Installation and Startup . . . . .	5 - 24
	Jumper settings . . . . .	5 - 24
	Removing and inserting the module . . . . .	5 - 24
	Controls and indicators . . . . .	5 - 26
5.2.3	Technical Specifications . . . . .	5 - 31

5.3	CPU 928 .....	5 - 33
5.3.1	Technical Description .....	5 - 33
	Application .....	5 - 33
	Design .....	5 - 33
	User memory .....	5 - 34
	Process interrupt processing .....	5 - 34
5.3.2	Installation and Startup .....	5 - 35
	Removing and inserting the module .....	5 - 35
	Controls and indicators .....	5 - 36
	Startup .....	5 - 40
5.3.3	Technical Specifications .....	5 - 41
5.4	CPU 922 .....	5 - 43
5.4.1	Technical Description .....	5 - 43
	Application .....	5 - 43
	Design .....	5 - 43
	Process interrupt processing .....	5 - 44
5.4.2	Installation and Startup .....	5 - 45
	Removing and inserting the module .....	5 - 45
	Controls and indicators .....	5 - 46
	Startup .....	5 - 50
5.4.3	Technical Specifications .....	5 - 51
5.5	374 Flash EPROM Cards .....	5 - 53
5.5.1	Technical Description .....	5 - 53
5.5.2	Notes on Operation .....	5 - 53
5.5.3	Technical Specifications .....	5 - 54
5.6	376 Memory Submodules .....	5 - 55
5.6.1	Technical Description .....	5 - 55
5.6.2	Notes on Operation .....	5 - 55
5.6.3	Technical Specifications .....	5 - 56
5.7	377 Memory Submodules .....	5 - 57
5.7.1	Technical Description .....	5 - 57
5.7.2	Notes on Operation .....	5 - 57
5.7.3	RAM Submodules with Battery Backup .....	5 - 58
	Operational states .....	5 - 58
	Battery monitoring and battery fault .....	5 - 59
	Inserting or replacing the backup battery .....	5 - 60
	Using the RAM submodule with battery backup .....	5 - 61
5.7.4	Technical Specifications .....	5 - 63

5.8	Interface Submodules . . . . .	5 - 65
5.8.1	Installing and Removing the Interface Submodules . . . . .	5 - 66
	Installation . . . . .	5 - 66
	Removal . . . . .	5 - 67
5.8.2	PG Submodule . . . . .	5 - 68
	Application . . . . .	5 - 68
	Circuitry . . . . .	5 - 68
	Data transmission rate . . . . .	5 - 68
	Pin assignments of the PG submodule . . . . .	5 - 69
	Jumper settings on the PG submodule . . . . .	5 - 70
	Standard connecting cable for the PG submodule . . . . .	5 - 71
5.8.3	V.24 Submodule . . . . .	5 - 72
	Application . . . . .	5 - 72
	Circuitry . . . . .	5 - 72
	Data transmission rate . . . . .	5 - 72
	Pin assignments of the V.24 submodule . . . . .	5 - 73
	Jumper settings of the V.24 submodule . . . . .	5 - 74
	Standard connecting cables of the V.24 submodule . . . . .	5 - 75
5.8.4	TTY Submodule . . . . .	5 - 79
	Application . . . . .	5 - 79
	Circuitry . . . . .	5 - 79
	Data transmission rate . . . . .	5 - 80
	Pin assignments of the	
	TTY submodule . . . . .	5 - 80
	Jumper settings on the	
	TTY submodule . . . . .	5 - 81
	Standard connecting cables for the TTY submodule . . . . .	5 - 82
5.8.5	RS422 A/485 Submodule . . . . .	5 - 85
	Application . . . . .	5 - 85
	Circuitry . . . . .	5 - 85
	Data transmission rate . . . . .	5 - 86
	Pin assignments of the RS422 A/485 submodule . . . . .	5 - 86
	Jumper settings on the RS422 A/485 submodule . . . . .	5 - 87
	Standard connecting cables to the RS422 A/485 submodule . . . . .	5 - 90
5.8.6	SINEC L1 Submodule . . . . .	5 - 91
	Application . . . . .	5 - 91
	Circuitry . . . . .	5 - 91
	Data transmission rate . . . . .	5 - 91
	Pin assignments of the SINEC L1 submodule . . . . .	5 - 92
	Jumper settings on the SINEC L1 submodule . . . . .	5 - 93
	BT 777 bus terminal . . . . .	5 - 93
	Connecting cable for point-to-point communication . . . . .	5 - 94
5.8.7	Technical Specifications of the Interface Submodules . . . . .	5 - 95



# CPUs, Memory Cards, Memory Submodules, Interface Submodules

# 5

# 5

This chapter contains information on the CPUs, memory cards, modules and submodules which you can use in your programmable controller.

The following CPUs may be fitted in an S5-135U/155U central controller:

- CPU 948
- CPU 928B
- CPU 928
- CPU 922.

A programmable controller containing a CPU 948 is known as an S5-155U PLC. A programmable controller containing CPUs 928B, 928 and/or 922 (and not the CPU 948) is known as an S5-135U PLC.

You can fit a flash EPROM memory card containing your user program in the CPU 948. For the CPUs 928B, 928 and 922, there are RAM or EPROM submodules for the purpose.

CPUs 948 and 928B have, apart from the programmer interface, a second serial interface. An interface submodule is required for physical adaptation.

## 5.1 CPU 948

This section contains the hardware description and the technical specifications of the CPU 948.

Details on programming the CPU 948 can be found in the CPU 948 Programming Guide.

### 5.1.1 Technical Description

This section contains information on the application, design and structure of the CPU 948.

#### **Application**

You can use the CPU 948 in single and multiprocessor operation in the S5-135U/155U central controller (see Chapter 6).

There are two versions of CPU 948:

- The CPU 948-1 offers 640 Kbytes of internal user memory (RAM).
- The CPU 948-2 offers 1664 Kbytes of internal user memory (RAM).

A SIMATIC S5 flash EPROM memory card (known as a memory card for short in the following) can be inserted in the CPU 948 as the storage medium for user program and user data. The contents of the memory card are copied into the internal RAM of the CPU upon overall reset.

The programming language is STEP 5 (LAD, CSF, STL, SCL). The CPU 948 processes all STEP 5 operations at very high speed, and uses fast floating-point arithmetic.

The following program processing levels are possible:

- Cyclic
- Time-controlled (9 different timebases, real-time controlled, timeout)
- Interrupt-driven from the S5 bus (8 process interrupts at block boundaries via IB0 or, alternatively, 4 system interrupts)
- Soft STOP.

**Design**

The electronic circuitry of the CPU 948, including the RAM, is on two PCBs of double Eurocard format which are screwed to each other. The two PCBs must not be separated. The front plate width of the module is  $2 \frac{2}{3}$  standard plug-in stations, i.e. 40 mm. In the central controller rack, the CPU 948 occupies two slots.

### 5.1.2 Installation and Startup

This section explains the installation and removal of the module in the CC, controls and indicators on the front plate of the CPU, and the procedure for module startup.

#### Jumper settings

There are four system interrupts for interrupt-driven program processing with the CPU 948:

- INTA/B/C/D (depending on the CPU slot, see also Section 4.1.1)
- INTE
- INTF
- INTG

The interrupts you wish to use must be enabled by inserting the jumper plugs provided. The jumper socket is situated on the basic board above the receptacle for the memory card. The exact location is given in the following figure:

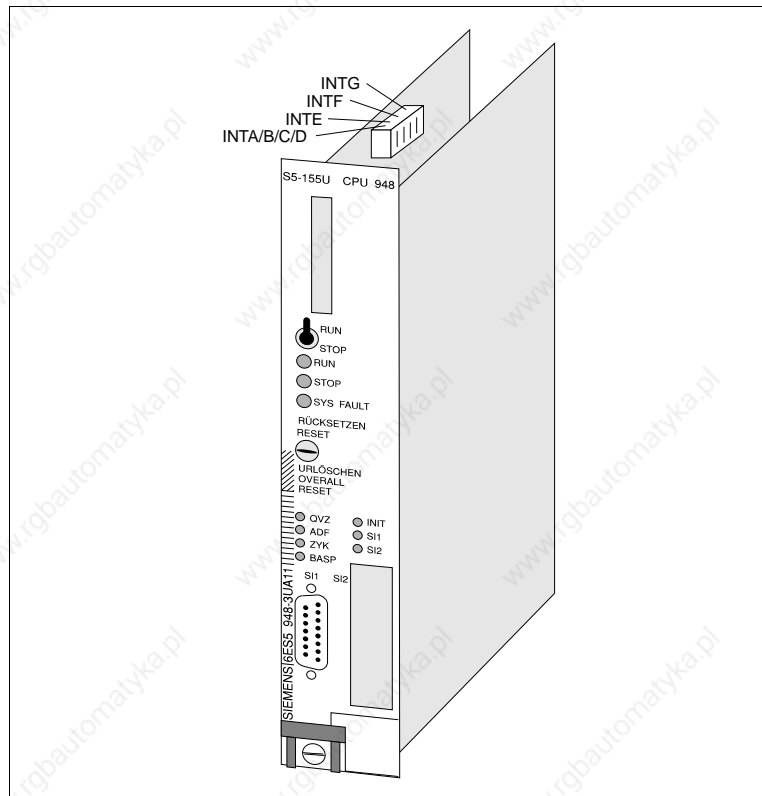

Figure 5-1 Location of Jumper Socket

#### Note

All other jumpers are required for quality testing by the manufacturer. You must not change these jumper settings.

### Removing and inserting the module



#### Caution

Switch off the power supply before removing or inserting the module.

The basic board and expansion board of the CPU 948 are one unit and must not be separated.

### Insertion

Proceed as follows to insert the CPU in the central controller:

Step	Action
1	Release the upper locking bar of the central controller and ensure that the locking pin for the module is correctly positioned with the slot-head horizontal.
2	Select the correct slot (based on the labelling of the locking bar). Insert the CPUs in the S5-135U/155U PLC from the extreme left at slot 11.
3	Push the module evenly into the guide rail until the lever over the locking pin is horizontal.
4	Press the locking pin inwards on the bottom of the module and rotate it 90° clockwise.
5	Secure the upper locking bar.

5

### Removal

Proceed as follows to remove the CPU

Step	Action
1	Release the upper locking bar of the central controller.
2	Release the locking pin of the module.
3	Press the release lever downwards and pull the module forwards and out of the central controller.

**Controls and indicators**

The controls and indicators are arranged on the front plate of the CPU module:

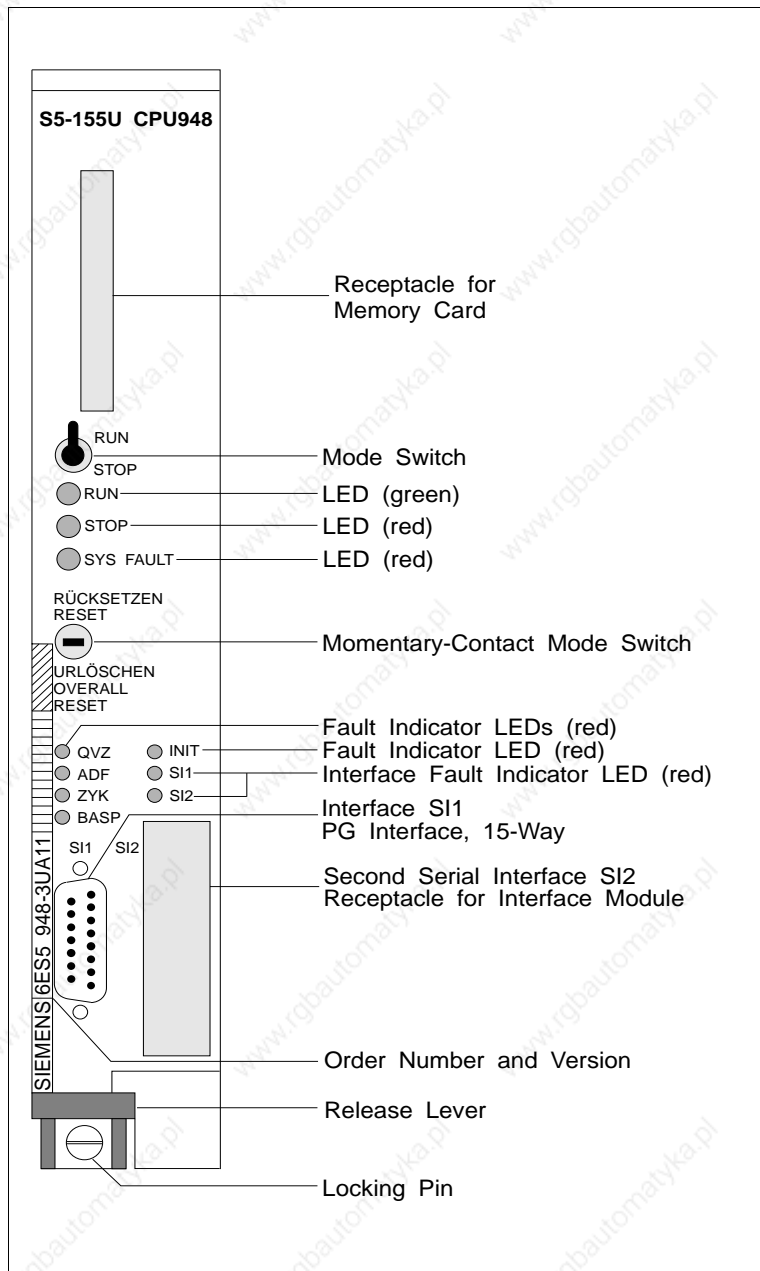

Figure 5-2 Controls and Indicators of the CPU 948

<i>Mode switch</i>	The mode switch has two settings:
<i>RUN</i>	In the RUN setting, the CPU 948 processes the user program when the green RUN LED is lit.
<i>STOP</i>	The CPU 948 will go to a soft STOP when you switch over from RUN to STOP. The red STOP LED will then light up.
<i>Momentary-contact mode switch</i>	You can initiate the Overall Reset, Reset and Restart functions with the momentary-contact mode switch and the mode changeover switch:
<i>OVERALL RESET</i>	<p>Momentary-contact switch down</p> <p>During an overall reset, the internal RAM is re-initialized, i.e. existing data will be erased and the contents of the memory card, if present, will be copied into the internal RAM.</p>
<i>RESET</i>	<p>Momentary-contact switch up</p> <p>During a reset, all flags, timers, counters and the process image will be erased. OB 20 will be invoked. Processing of the user program will start from the beginning again.</p>
<i>Restart</i>	<p>Momentary-contact switch at midpoint</p> <p>With a restart, processing of the user program will continue from the point of interruption. The statuses of flags, timers, counters and the process image are retained during stoppage of the CPU.</p>

**Status indicators**

Given in the following overview are the functions of the RUN, STOP and SYS FAULT status LEDs.

The STOP LED indicates a soft stop; the SYS FAULT LED indicates a hard STOP.

The CPU 948 can process a user program (OB 39) cyclically at the soft STOP, but the digital outputs remain inhibited. At the hard STOP, no program can run and the CPU has "stopped". This state can only be exited by switching the system voltage off and on again.

<b>RUN LED</b>	<b>STOP LED</b>	<b>SYS FAULT LED</b>	<b>Status</b>
on	off	off	The CPU is in the RUN state (cyclic operation).
on	on	on	Appears briefly after power-up of the unit.
off	off	off	CPU is in the initial start or program check state.
off	on	off	CPU is in the soft STOP state.
off	rapid flashing	off	CPU is in the soft STOP state. Overall reset has been requested by switch or from the operating system.
off	slow flashing	off	CPU is in the soft STOP state. An error has occurred; see the CPU 948 Programming Guide for possible causes.
off	off	on	CPU is in the hard STOP state. No program processing is taking place. You can only exit from this state by switching the system voltage off and on again.



**LEDs for fault indication and signalling**

Given in the following overview are the causes for LEDs lighting up:

<b>QVZ LED</b>	
on	<p>A module addressed by the program no longer acknowledges although/because</p> <ul style="list-style-type: none"> <li>• it <i>either</i> acknowledged in single-processor operation upon restart of the CPU 948 in the area of the process image (IB0 to 127, QB0 to 127) and has been entered as present in the so-called 9th track;</li> <li>• <i>or</i> it has been entered in multi or single-processor operation in DB 1 (address list) and has been recognized as present during the restart;</li> <li>• <i>or</i> it was addressed in direct access by operations LPY, LPW, TPY, TPW, LOY, LOW, TOY, TOW;</li> <li>• <i>or</i> the data handling blocks cannot access the module.</li> </ul> <p><b>Possible causes:</b></p> <ul style="list-style-type: none"> <li>• Module failure</li> <li>• Module removed during operation, in the STOP state or in the Off state without subsequent restart.</li> </ul> <p>A timeout occurred during access to the user memory.</p>
<b>ADF LED</b>	
on	<p>The user program has referred to an address in the process image under which no module was inserted in the I/Os or was not entered in DB 1 during the last restart.</p>
<b>ZYK LED</b>	
on	<p>The preset cycle time monitor has responded and cyclic program processing is interrupted.</p>
<b>BASP LED</b>	
on	<p>Command output is inhibited and the digital outputs will be directly switched to the safe state (0).</p>
<b>INIT LED</b>	
on	<p>This LED is continuously lit for a short time during initialization after power ON and during operation in the event of system faults.</p>

A detailed description of interrupt and error handling can be found in the CPU 948 Programming Guide.

**Fault LEDs SI1 and SI2**

LEDs SI1 and SI2 indicate faults in communication via interfaces SI1 and SI2:

<b>LED SI1</b>	<b>LED SI2</b>	<b>Cause</b>
on	on	Communication is not possible at both interfaces. Internal fault.
on	off	SI1: No communication possible. Internal fault.  SI2: Interface is initialized and ready. LED SI2 is always off if no interface module is inserted.
off	on	SI1: Interface is initialized and ready.  SI2: No communication possible. Wrong module inserted or internal fault.
off	off	Both interfaces are initialized and ready. LED SI2 is always off if no interface module is inserted.

**Startup**

The modules must be inserted at the correct slots in the central controller. The backup battery must be fitted and in order for the CPU to start.

**Overall reset**

Proceed as follows:

Step	Action	Result
1	Set the mode switch to STOP.	
2	Switch the system voltage on.	The following LEDs must light up on the CPU: - Red STOP LED (flashing rapidly) - Red INIT LED, briefly - Red BASP <sup>2)</sup> LED
3	Hold the MC <sup>1)</sup> switch in the OVERALL RESET setting and simultaneously set the mode switch from STOP to RUN.	The red STOP LED is now permanently lit.

<sup>1)</sup> MC: Momentary-contact

<sup>2)</sup> BASP: Command output inhibit

If the red SYS FAULT LED also lights up, an error has occurred during overall reset. In this case the measures described must be repeated. If necessary, switch the system voltage off and on again. If the LED is still lit, the module is faulty.

**Restart**

Continue as follows:

Step	Action	Result
4	Set the mode switch to STOP.	
5	Hold the MC switch in the RESET setting and simultaneously set the mode switch from STOP to RUN.	- Red STOP LED goes off - Green RUN LED lights up - Red BASP LED goes off  The CPU is now in the RUN state but still has no user program.

**Restart**

You can also carry out a manual restart of the CPU 948 with the mode switch. The CPU 948 Programming Guide will indicate when a manual restart is permissible.

<b>Step</b>	<b>Action</b>	<b>Result</b>
1	Set the mode switch from STOP to RUN	<ul style="list-style-type: none"><li>- Red STOP LED goes off</li><li>- RUN LED lights up</li><li>- Red BASP LED goes off</li></ul>

For maintenance purposes or in the event of a fault, this startup without user program in single-processor operation can serve to establish whether the CPU is operating without errors.

### 5.1.3 Interfaces of the CPU 948

This section contains information on the interfaces of the CPU 948.

#### *PG interface SI1*

You can use the PG interface on the CPU 948 either via the front connector or via the 923C coordinator module and the S5 bus.

#### **Note**

Simultaneous operation of the PG interface via the front connector of the CPU 948 and via the 923C coordinator is not possible. Switching the PG online without a job request is already sufficient to operate the interface. Electrically, it is merely a PG interface which can be operated via two different terminals.

**5**

The connection to the PG can be established in every operational state of the CPU.

#### *Interface SI2*

You can also use the second interface of the CPU 948 as a PG interface. Physical adaptation is achieved with a PG module (see also Section 5.8, Interface Submodules).

A detailed description of PG interfaces can be found in the CPU 948 Programming Guide.

#### *Communication via parallel backplane bus with SINEC H1*

A PG-PLC link via SINEC H1 allows very advanced communication between the partners. For example, the user software can be loaded into the CPU 948 up to eight-times faster than with serial communication.

For this link you will need, in addition to the CPU 948, a CPU 143 (Version  $\geq 2.1$ ) in the PLC and a PG7xx with SINEC H1 connection and the STEP 5 single-tasking software from Version 6.0 or multi-tasking from Version 2.0.

#### **Note**

You cannot implement communication via SINEC H1 in parallel with the serial interfaces.

Communication via SINEC H1 is described in detail in the CPU 948 Programming Guide.

### 5.1.4 Technical Specifications

#### Important for the USA and Canada

The following approvals have been obtained:



UL Listing Mark  
Underwriters Laboratories (UL) to  
Standard UL 508, Report E 85972



CSA Certification Mark  
Canadian Standard Association (CSA) to  
Standard C 22.2 No. 142, Report LR 63533

Type of protection	IP 00				
Climatic ambient conditions	See Technical Specifications of the S5-135U/155U CC				
Mechanical ambient conditions	See Technical Specifications of the S5-135U/155U CC				
Noise immunity, electromagnetic compatibility (EMC)	See Technical Specifications of the S5-135U/155U CC				
Supply voltage	5 V ± 5 %				
Current consumption at 5 V	3.6 A typical				
Backup voltage	3.4 V				
Backup current	10 µA typical (at 25 °C)				
	P area	O area	IM3 area	IM4 area	Total
Digital inputs with process image	1024 max.	–	–	–	1024 max.
Digital inputs without process image or analog inputs	1024 max. 64 max.	2048 max. 128 max.	2048 max. 128 max.	2048 max. 128 max.	7168 max. 448 max.
Digital outputs with process image	1024 max.	–	–	–	1024 max.
Digital outputs without process image or analog outputs	1024 max. 64 max.	2048 max. 128 max.	2048 max. 128 max.	2048 max. 128 max.	7168 max. 448 max.
Flags	2048				
S flags	32768				
Timers	256				
Counters	256				
Size of user memory	640 or 1664 Kbyte RAM				
Transmission rate of serial PG interface	9600 bit/s				
Program blocks PB	256				
Sequence blocks SB	256				
Function blocks FB	256				

Function blocks FX	256
Data blocks DB	256, of which 253 are freely available
Data blocks DX	256, of which 253 are freely available
Organization blocks OB	OB 1 to 39 (interfaces for operating system)
Integrated special function organization blocks OB	OB 121, 122, 124-126, 131-133, 141-143, 150, 151, 153, 200, 202-205, 222, 223, 254, 255
Integrated serial interface	PG interface
Optional serial interface	PG interface with PG submodule
Backplane bus	S5 bus
Dimensions (w x h x d)	40.6 x 233.4 x 160 mm
Weight	Approx. 1 kg

## 5.2 CPU 928B

This section contains the hardware description and technical specifications of the CPU 928B.

Details on programming the CPU 928B can be found in the CPU 928B Programming Guide.

### 5.2.1 Technical Description

#### **Application**

You can use the CPU 928B in single and multiprocessor operation in the S5-135U/155U central controller (see Chapter 6). Up to four CPUs can be used.

The CPU 928B is universally applicable, ensuring both very fast bit processing and very fast word processing.

The following program processing levels are possible:

- Cyclic
- Time-controlled (9 different timebases)
- Real-time controlled
- Interrupt-driven (hardware interrupt)
- Delayed (from Version 6ES5 928-3UB12)

The programming language is STEP 5.

#### **Design**

The electronic circuitry of the CPU 928B is on two PCBs (basic and expansion boards) in the double Eurocard format. Both PCBs are screwed together, linked via connectors, and must not be separated. The basic board provides the connection to the S5 bus via two backplane connectors.

The front plate width is 2 2/3 standard plug-in stations.



### **User memory**

You require a user memory submodule (RAM or EPROM) for storage of your program. You can store up to 64 Kbytes of code and data blocks here. For data blocks, the CPU 928B additionally has an integrated DB RAM of 46 3/4 Kbytes.

A description of the memory submodules can be found in Sections 5.6 and 5.7; order numbers are given in the ordering information.

### **PG Interface SI1**

There are two independent interfaces on the front of the CPU 928B.

You can connect programmers and OPs to the first interface. This PG interface SI1 is permanently installed on the CPU.

You can use PG interface SI1 either via the front connector of the CPU 928B or via the front connector of the 923C coordinator module.

#### **Note**

Simultaneous operation of PG interface SI1 via the front connector of the CPU 928B and of the coordinator is not possible. Electrically, it is merely a PG interface which can be operated via two different terminals. Switching the programmer online without a job request is already sufficient to operate the interface.

If you wish to utilize a second PG interface for connection of a PG or OP, the connection must be made via the second PG interface with the PG submodule.

Apart from PG interface SI1, the second interface SI2 can also be used as a PG interface in parallel with the first one. You can only use the second PG interface via the front connector of the PG submodule on the CPU 928B.

A detailed description of operations with the two PG interfaces can be found in the CPU 928B Programming Guide.

The connection to the PG can be established with the CPU in any operational state.

## Second interface SI2

You can optionally use the second interface of the CPU 928B as:

- A PG interface (for PG and operator panels)
- Interface for the RK 512 computer link
- Interface for data transmission with procedures 3964/3964R
- Interface for data transmission with the "open driver"
- Interface for data transmission via the SINEC L1 bus (from Version 6ES5 928-3UB12).

To utilize the second interface as the PG interface, you need the

- PG submodule.

You need one of the following interface submodules for the RK 512 computer link, for data transmission with procedures 3964/3964R and for data transmission with the "open driver":

- V.24 submodule (RS 232C)
- TTY submodule
- RS422 A/485 submodule (only in the RS422 A module).

To utilize the second interface for data transmission via the SINEC L1 bus, you need the

- SINEC L1 submodule (from Version 6ES5 928-3UB12).

The CPU 928B is delivered without an interface submodule. You can operate the CPU 928B without an integral interface submodule. The opening to accept a submodule in the front plate is closed by a cover. Only remove the cover to fit an interface submodule.

A description of interface submodules can be found in Section 5.8, and the order numbers in the ordering information.

A detailed description of the second interface can be found in the CPU 928B Communication Manual.

### **Process interrupt processing**

There is an interrupt line in the PLC for each CPU. It can be used when the reaction to an event must occur with higher priority than the reaction to other events.

To process an interrupt, cyclic program processing is interrupted and the program stored in OB 2 (OB for interrupt processing) is inserted. (Refer to the CPU 928B Programming Guide for further details.)

This interrupt-driven program processing is only possible using an interrupt-capable digital input module or a suitable operating CP/IP module.

No jumper setting on the CPU 928B is required. Please note, however, that the usable interrupt line on the backplane bus depends on the CPU slot and must be set accordingly on the I/O module (see Section 4.1).

## **5.2.2 Installation and Startup**

### **Jumper settings**

#### **Note**

All jumpers on the CPU 928B are required by the manufacturer for quality testing. You must not change the jumper settings.

### **Removing and inserting the module**



#### **Caution**

Switch off the power supply before removing or inserting the module.

The basic board and expansion board of the CPU 928B are one unit and must not be separated.

**Insertion**

Proceed as follows to insert the CPU in the central controller:

Step	Action
1	Release the upper locking bar of the central controller and ensure that the locking pin for the module is correctly positioned with the slot-head horizontal.
2	Select the correct slot (based on the labelling of the locking bar). Insert the CPUs in the S5-135U/155U from slot 11.
3	Push the module evenly into the guide rail until the lever over the locking pin is horizontal.
4	Press the locking pin inwards on the bottom of the module and rotate it 90° clockwise.
5	Secure the upper locking bar.

5

**Removal**

Proceed as follows to remove the CPU:

Step	Action
1	Release the upper locking bar of the central controller.
2	Release the locking pin of the module.
3	Press the release lever downwards and pull the module forwards and out of the central controller.

**Note**

Only operate the CPU 928B with the submodule receptacle closed. You close it either by fitting an interface submodule or with the cover supplied.  
Please tighten both screws (EMC)!

**Controls and indicators**

The controls and indicators are arranged on the front plate of the CPU module:

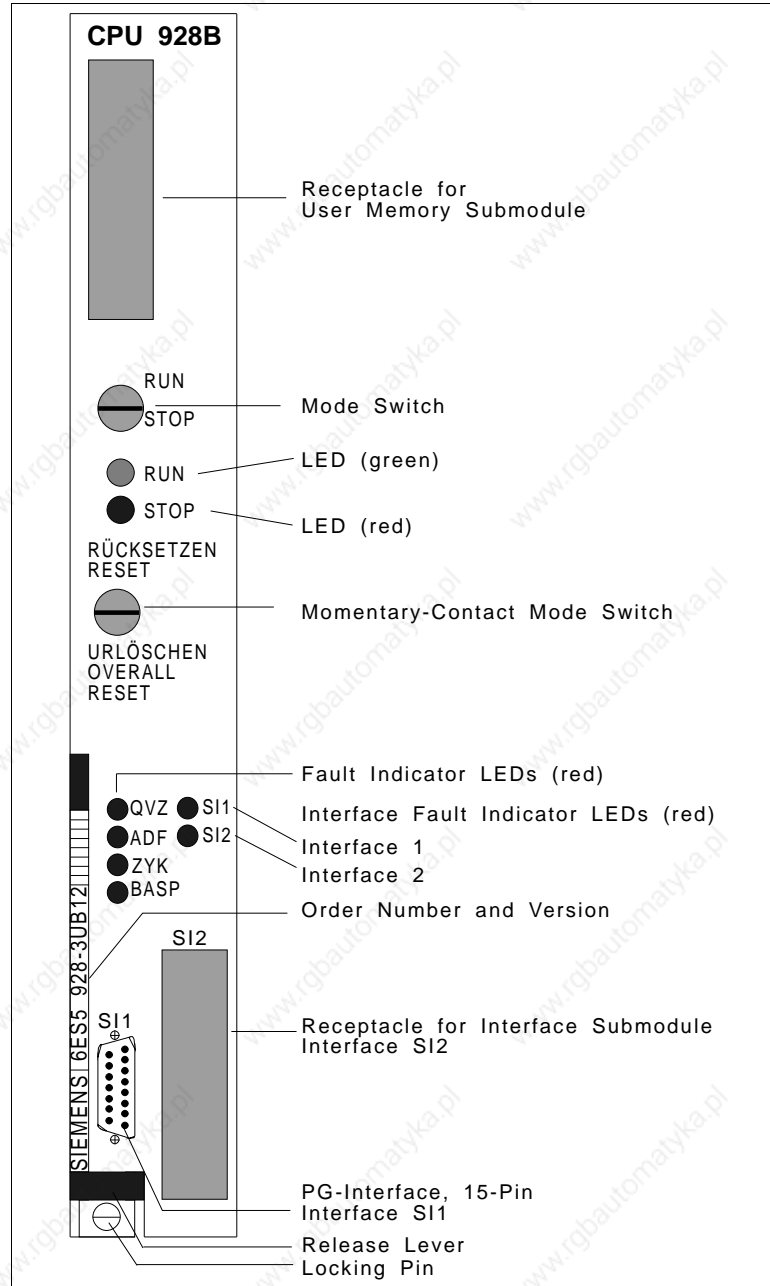

Figure 5-3 Front Plate of the CPU 928B

<i>Mode switch</i>	The mode switch has two settings:
<i>RUN</i>	In the RUN setting, the CPU 928B processes the user program when the green RUN LED is lit.
<i>STOP</i>	The CPU 928B goes to the stop state when you switch from RUN to STOP. The red STOP LED then lights up.

*Momentary-contact mode switch* You can initiate the Overall Reset, Reset and Restart functions with the momentary-contact mode switch:

*OVERALL RESET* Momentary-contact switch down  
With an overall reset, all RAM areas are erased and initialized (both on the CPU and on a RAM submodule).

*RESET* Momentary-contact switch up  
During a reset, all flags, timers, counters and the process image will be erased. OB 20 will be invoked. Processing of the user program will start from the beginning again.

*Restart* Momentary-contact switch at midpoint  
With a restart, processing of the user program will continue from the point of interruption. The statuses of flags, timers, counters and the process image are retained during stoppage of the CPU.

## Status indicators

RUN LED	STOP LED	Status
on	off	The CPU is in the RUN state.
off	on	The CPU is in the STOP state. After a stop request by switch or PG function, the STOP LED is continuously lit because the transition to the STOP state was requested by the user or, in multiprocessor operation, by another CPU, and was not caused by the CPU itself.
off	off	The CPU is in the INITIAL START or program check state.
off	slow flashing	The CPU is in the STOP state. The CPU has caused a transition to the STOP state (possibly also for the other CPUs). If you set the mode switch to STOP, the flashing LED becomes continuously lit.
off	rapid flashing	The CPU is in the STOP state. An overall reset has been requested. This request can be initiated by the CPU itself or by operator action.

## LEDs for fault indication and signalling

QVZ LED	
on	<p>During direct access or process image update, a module addressed by the program no longer acknowledges although</p> <ul style="list-style-type: none"> <li>• <i>either</i> it has acknowledged in single-processor operation upon reset of the CPU 928B in the area of the process image (IB 0 to 127, QB 0 to 127) and has been entered as present in the "9th track" (see Programming Guide, CPU 928B),</li> <li>• <i>or</i> it has been entered in DB 1 (address list) in multiprocessor or single-processor operation and has been recognized as present during the reset.</li> </ul> <p><b>Possible causes</b></p> <ul style="list-style-type: none"> <li>• Module failure.</li> <li>• Module was pulled out during operation, in the STOP state or in the Off state without a subsequent reset.</li> </ul>

<b>ADF LED</b>	
on	The user program has referenced an I/O address in the process image under which no module is inserted.
<b>ZYK LED</b>	
on	The maximum cycle monitoring time has been exceeded.
<b>BASP LED</b>	
on	Command output is inhibited and the digital outputs will be directly switched to the safe state.

A detailed description of interrupt and error handling can be found in the CPU 928B Programming Guide.

LED SI 1	LED SI 2	Cause
on	on	No communication possible at both interfaces. Internal error.
on	off	SI1: No communication possible. Internal error. SI2: If used, interface is initialized and ready.
off	on	SI1: Interface is initialized and ready. SI2: No communication possible. Wrong interface submodule inserted or wrong parameters for interface or internal error.
off	off	First interface and, if used, second interface are initialized and ready.



**Startup**

The modules must be inserted at the correct slots in the central controller. The backup battery must be fitted and in order for the CPU to start.

**Overall reset**

Step	Action	Result
1	Set the mode switch to STOP.	
2	Switch the system voltage on.	The following LEDs must light up on the CPU: - Red STOP LED (flashing rapidly) - Red BASP <sup>2)</sup> LED
3	Hold the MC <sup>1)</sup> switch in the OVERALL RESET setting and simultaneously set the mode switch from STOP to RUN.	The red STOP LED is now permanently lit.

<sup>1)</sup> MC: Momentary-contact

<sup>2)</sup> BASP: Command output inhibit

**Reset**

Step	Action	Result
4	Set the mode switch to STOP.	
5	Hold the MC switch in the RESET setting and simultaneously set the mode switch from STOP to RUN.	- Red STOP LED goes off - Green RUN LED lights up - Red BASP LED goes off The CPU is now in the RUN state but still has no user program.

**Restart**

You can also carry out a manual restart of the CPU 928B with the mode switch. The CPU 928B Programming Guide will indicate when a manual restart is permissible.

Step	Action	Result
1	Set the mode switch from STOP to RUN.	- Red STOP LED goes off - Green RUN LED lights up - Red BASP LED goes off

For maintenance purposes or in the event of a fault, this startup without user program in single-processor operation can serve to establish whether the CPU is operating without errors.

### 5.2.3 Technical Specifications

#### Important for the USA and Canada

The following approvals have been obtained:



UL Listing Mark  
Underwriters Laboratories (UL) to  
Standard UL 508, Report E 85972



CSA Certification Mark  
Canadian Standard Association (CSA) to  
Standard C 22.2 No. 142, Report LR 63533

Type of protection	IP 00				
Climatic ambient conditions	See Technical Specifications of the S5-135U/155U CC				
Mechanical ambient conditions	See Technical Specifications of the S5-135U/155U CC				
Noise immunity, electromagnetic compatibility (EMC)	See Technical Specifications of the S5-135U/155U CC				
Supply voltage	5 V $\pm$ 5 % 24 V + 25 %/- 17 %				
Current consumption at 5 V	5 A typical				
Current consumption at 24 V	760 mA max.				
Backup voltage	3.4 V				
Backup current without user RAM submodule	20 $\mu$ A typical (at 25 °C)				
	P area	O area	IM3 area	IM4 area	Total
Digital inputs with process image	1024 max.	–	–	–	1024 max.
Digital inputs without process image	1024 max.	2048 max.	2048 max.	2048 max.	7168 max.
or analog inputs	64 max.	128 max.	128 max.	128 max.	448 max.
Digital outputs with process image	1024 max.	–	–	–	1024 max.
Digital outputs without process image	1024 max.	2048 max.	2048 max.	2048 max.	7168 max.
or analog outputs	64 max.	128 max.	128 max.	128 max.	448 max.
Flags	2048				
S flags	8192				
Timers	256				
Counters	256				
Size of user memory	64 Kbyte max., EPROM or RAM				
DB RAM	46 3/4 x 2 <sup>10</sup> Kbyte				
Transmission rate of the serial PG interface	9600 bit/s				

Program blocks PB	256
Sequence blocks SB	256
Function blocks FB	256
Function blocks FX	256
Data blocks DB	256, of which 253 are freely available
Data blocks DX	256, of which 253 are freely available
Organization blocks OB	OB 1 to 39 (interfaces for operating system)
Integrated special function organization blocks OB	See Pocket Guide
Integrated serial interface	PG interface
Optional serial interface	Via interface submodules, optionally as V.24, TTY, RS 422A/485 or PG interface, SINEC L1 interface from Version 6ES5 928-3UB12
Backplane bus	S5 bus
Dimensions (w x h x d)	40.64 x 233.4 x 160 mm
Weight	Approx. 1 kg

## 5.3 CPU 928

This section contains the hardware description and technical specifications of the CPU 928.

Details on programming the CPU 928 can be found in the CPU 928 Programming Guide.

### 5.3.1 Technical Description

#### **Application**

You can use the CPU 928 in single and multiprocessor operation in the S5-135U/155U central controller (see Chapter 6). Up to four CPUs can be used.

The CPU 928 is universally applicable, ensuring both very fast bit processing (optimized for open-loop tasks) and word processing (optimized for closed-loop tasks).

The following program processing levels are possible:

- Cyclical
- Time-controlled (9 different timebases)
- Interrupt-driven (hardware interrupt)

The programming language is STEP 5.

#### **Design**

The CPU 928 comprises two PCBs (PCB 1 and PCB 2) in the double Eurocard format, in a sandwich assembly. The two PCBs have plug-in interconnections and are bolted together as a unit when delivered. PCB 2 serves as the basic board which provides the connection to the S5 bus via two backplane connectors.

The front plate width is 2 2/3 standard plug-in stations.

**User memory**

You require a user memory submodule (RAM or EPROM) for storage of your program. You can store up to 64 Kbytes of code and data blocks here. For data blocks, the CPU 928 additionally has an integrated DB RAM of 46 3/4 Kbytes.

**Note**

The DB RAM is loaded with DB/DX blocks when the RAM submodule is full or an EPROM submodule is plugged in.

A description of the memory submodules can be found in Sections 5.6 and 5.7; order numbers are given in the ordering information.

**Process interrupt processing**

There is an interrupt line (IR) in the PLC for each CPU. It can be used when the reaction to one or more events must occur with higher priority than the reaction to other events.

To process an interrupt, cyclic program processing is interrupted and the program stored in OB 2 (OB for interrupt processing) is inserted. (Refer to the CPU 928 Programming Guide for further details.)

This interrupt-driven program processing is only possible using an interrupt-capable digital input module (e.g. 6ES5 432-...) or a suitably operating CP/IP module.

### 5.3.2 Installation and Startup

#### Removing and inserting the module



#### Caution

Switch off the power supply before removing or inserting the module.

The basic board and expansion board of the CPU 928 are one unit and must not be separated.

#### Insertion

Proceed as follows to insert the CPU in the central controller:

**5**

Step	Action
1	Release the upper locking bar of the central controller and ensure that the locking pin for the module is correctly positioned with the slot-head horizontal.
2	Select the correct slot (based on the labelling of the locking bar). Insert the CPUs in the S5-135U/155U from slot 11.
3	Push the module evenly into the guide rail until the lever over the locking pin is horizontal.
4	Press the locking pin inwards on the bottom of the module and rotate it 90° clockwise.
5	Secure the upper locking bar.

#### Removal

Proceed as follows to remove the CPU:

Step	Action
1	Release the upper locking bar of the central controller.
2	Release the locking pin of the module.
3	Press the release lever downwards and pull the module forwards and out of the central controller.

**Controls and indicators**

The controls and indicators are arranged on the front plate of the CPU module:

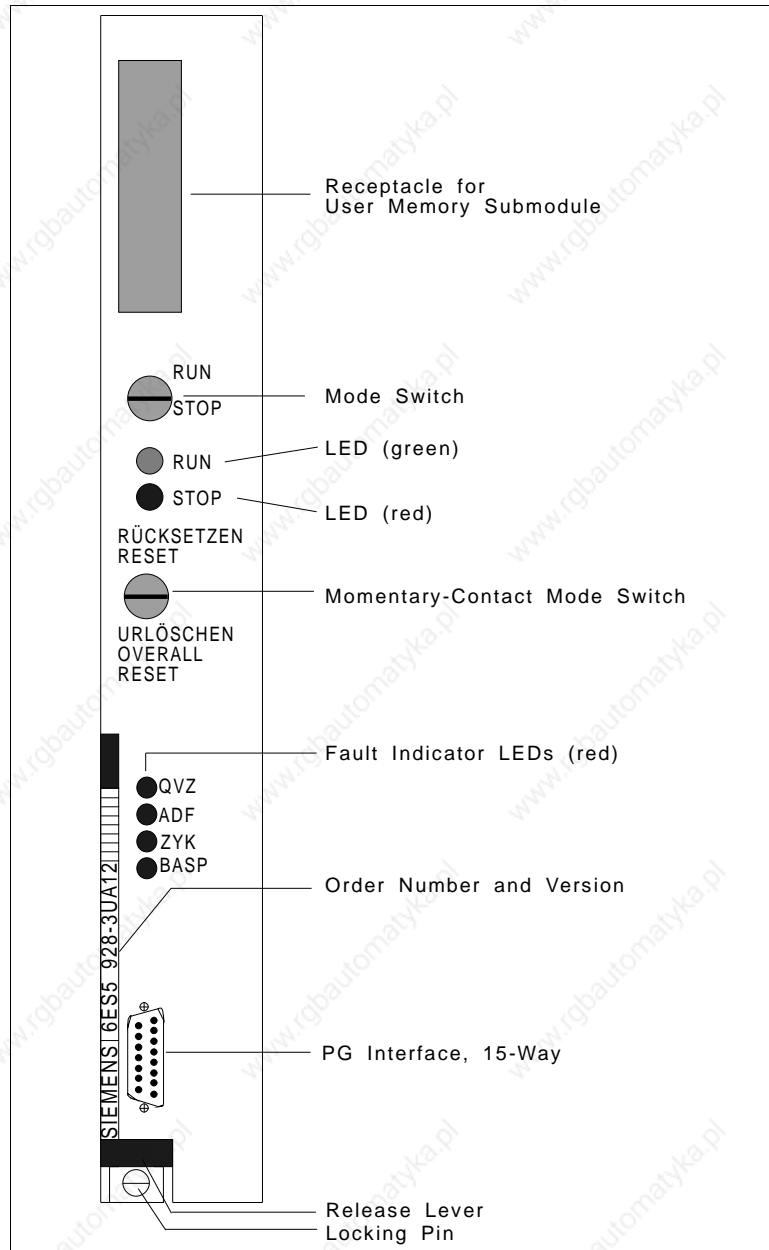

Figure 5-4 Front Plate of the CPU 928

<i>Mode switch</i>	The mode switch has two settings:
<i>RUN</i>	In the RUN setting, the CPU 928 processes the user program when the green RUN LED is lit.
<i>STOP</i>	The CPU 928 goes to the stop state when you switch from RUN to STOP. The red STOP LED then lights up.
<i>Momentary-contact mode switch</i>	You can initiate the Overall Reset, Reset and Restart functions with the momentary-contact mode switch:
<i>OVERALL RESET</i>	Momentary-contact switch down With an overall reset, all RAM areas are erased and initialized (both on the CPU and on a RAM submodule).
<i>RESET</i>	Momentary-contact switch up During a reset, all flags, timers, counters and the process image will be erased. OB 20 will be invoked. Processing of the user program will start from the beginning again.
<i>Restart</i>	Momentary-contact switch at midpoint With a restart, processing of the user program will continue from the point of interruption. The statuses of flags, timers, counters and the process image are retained during stoppage of the CPU.



## Status indicators

<b>RUN LED</b>	<b>STOP LED</b>	<b>Status</b>
on	off	The CPU is in the RUN state.
off	on	The CPU is in the STOP state. After a stop request by switch or PG function, the STOP LED is continuously lit because the transition to the STOP state was requested by the user or, in multiprocessor operation, by another CPU, and was not caused by the CPU itself.
off	off	The CPU is in the INITIAL START or program check state.
off	slow flashing	The CPU is in the STOP state. The CPU has caused a transition to the STOP state (possibly also for the other CPUs). If you set the mode switch to STOP, the flashing LED becomes continuously lit.
off	rapid flashing	The CPU is in the STOP state. An overall reset has been requested. This request can be initiated by the CPU itself or by operator action.

LEDs for fault indication and signalling

<b>QVZ LED</b>	
on	<p>During direct access or process image update, a module addressed by the program no longer acknowledges although</p> <ul style="list-style-type: none"> <li>• <i>either</i> it has acknowledged in single processor operation upon reset of the CPU 928 in the area of the process image (IB 0 to 127, QB 0 to 127) and has been entered as present in the "9th track" (see Programming Guide, CPU 928),</li> <li>• <i>or</i> it has been entered in DB 1 (address list) in multiprocessor or single-processor operation and has been recognized as present during the reset.</li> </ul> <p><b>Possible causes</b></p> <ul style="list-style-type: none"> <li>• Module failure.</li> <li>• Module was pulled out during operation, in the stop state or in the Off state without a subsequent reset.</li> </ul>
<b>ADF LED</b>	
on	The user program has referenced an I/O address under which no module is inserted.
<b>ZYK LED</b>	
on	The maximum cycle time has been exceeded.
<b>BASPLED</b>	
on	Command output is inhibited and the digital outputs will be directly switched to the safe state.

A detailed description of interrupt and error handling can be found in the CPU 928 Programming Guide.

**Startup**

The modules must be inserted at the correct slots in the central controller. The backup battery must be fitted and in order for the CPU to start.

**Overall reset**

Step	Action	Result
1	Set the mode switch to STOP.	
2	Switch the system voltage on.	The following LEDs must light up on the CPU: - Red STOP LED (flashing rapidly) - Red BASP LED
3	Hold the MC <sup>1)</sup> switch in the OVERALL RESET setting and simultaneously set the mode switch from STOP to RUN.	The red STOP LED is now permanently lit.

<sup>1)</sup>MC: Momentary-contact

**Reset**

Step	Action	Result
4	Set the mode switch to STOP.	
5	Hold the MC switch in the RESET setting and simultaneously set the mode switch from STOP to RUN.	- Red STOP LED goes off - Green RUN LED lights up - Red BASP LED goes off The CPU is now in the RUN state but still has no user program.

**Restart**

You can also carry out a manual restart of the CPU 928 with the mode switch. The CPU 928 Programming Guide will indicate when a manual restart is permissible.

Step	Action	Result
1	Set the mode switch from STOP to RUN.	- Red STOP LED goes off - Green RUN LED lights up - Red BASP LED goes off

For maintenance purposes or in the event of a fault, this startup without user program in single-processor operation can serve to establish whether the CPU is operating without errors.

### 5.3.3 Technical Specifications

#### Important for the USA and Canada

The following approvals have been obtained:



UL Listing Mark  
Underwriters Laboratories (UL) to  
Standard UL 508, Report E85972



CSA Certification Mark  
Canadian Standard Association (CSA) to  
Standard C 22.2 No. 142, Report LR 63533

Type of protection	IP 00				
Climatic ambient conditions	See Technical Specifications of the S5-135U/155U CC				
Mechanical ambient conditions	See Technical Specifications of the S5-135U/155U CC				
Noise immunity, electromagnetic compatibility (EMC)	See Technical Specifications of the S5-135U/155U CC				
Supply voltage	5 V $\pm$ 5 %				
Current consumption at 5 V	3.5 A typical				
Backup voltage	3.4 V				
Backup current without user RAM submodule	20 $\mu$ A typical (at 25 °C)				
	P area	O area	IM3 area	IM4 area	Total
Digital inputs with process image	1024 max.	–	–	–	1024 max.
Digital inputs without process image or analog inputs	1024 max. 64 max.	2048 max. 128 max.	2048 max. 128 max.	2048 max. 128 max.	7168 max. 448 max.
Digital outputs with process image	1024 max.	–	–	–	1024 max.
Digital outputs without process image or analog outputs	1024 max. 64 max.	2048 max. 128 max.	2048 max. 128 max.	2048 max. 128 max.	7168 max. 448 max.
Flags	2048				
Timers	256				
Counters	256				
Size of user memory	max. of 64 K words, EPROM or RAM				
DB RAM	46 3/4 Kbytes				
Transmission rate of serial PG interface	9600 bit/s				
Program blocks PB	256				
Sequence blocks SB	256				
Function blocks FB	256				
Function blocks FX	256				

Data blocks DB	256, of which 253 are freely available
Data blocks DX	256, of which 253 are freely available
Organization blocks OB	OB 1 to 39 (interfaces for operating system)
Integrated special function organization blocks OB	See Pocket Guide
Dimensions (w x h x d)	40.64 x 233.4 x 160 mm
Weight	Approx. 1 kg

## 5.4 CPU 922

This section contains the hardware description and technical specifications of the CPU 922 (also known as the R processor).

Details on programming can be found in the CPU 922 Programming Guide.

### 5.4.1 Technical Description

#### *Application*

You can use the CPU 922 in single and multiprocessor operation in the S5-135U/155U CC (see Chapter 6). Up to four CPUs can be used.

The CPU 922 is particularly suitable for word processing (closed-loop control and arithmetic calculation). Binary signal processing is also possible.

The following program processing levels are possible:

- Cyclic
- Time-controlled (1 timebase)
- Interrupt-driven (hardware interrupt).

The programming language is STEP 5.

#### *Design*

The module is designed as a plug-in PCB of double Eurocard format. The module provides the connection to the S5 bus via two backplane connectors.

The front plate width is 1 1/3 standard plug-in stations.

### ***User memory***

You require a user memory submodule (RAM or EPROM) for storage of your program. You can store up to 64 Kbytes of code and data blocks here. For data blocks, the CPU 922 additionally has an integrated DB RAM of 22 Kbytes.

#### **Note**

The DB RAM is only loaded with DB/DX blocks when the RAM submodule is full or an EPROM submodule is inserted.

A description of the memory submodules can be found in Sections 5.6 and 5.7; order numbers are given in the ordering information.

### ***Process interrupt processing***

There is an interrupt line (IR) in the S5-135U/155U PLC for each CPU. It can be used when the reaction to one or more events must occur with higher priority than the reaction to other events.

To process an interrupt, cyclic program processing is interrupted and the program stored in OB 2 is inserted. Refer to the CPU 922 Programming Guide for further details.

This interrupt-driven program processing is only possible using an interrupt-capable digital input module (e.g. 6ES5 432-...) or a suitably operating CP/IP module.

## 5.4.2 Installation and Startup

### Removing and inserting the module



#### Caution

Switch off the power supply before removing or inserting the module.

#### Insertion

Proceed as follows to insert the CPU in the central controller:

Step	Action
1	Release the upper locking bar of the central controller.
2	Select the correct slot (based on the labelling of the locking bar). Insert the CPUs in the S5-135U/155U from slot 11.
3	Push the module evenly into the guide rail.
4	Secure the upper locking bar.

**5**

#### Removal

Proceed as follow to remove the CPU:

Step	Action
1	Release the upper locking bar of the central controller.
2	Use the grips and gentle upward and downward motion to pull the CPU forwards out of the CC.



**Controls and indicators**

The controls and indicators are arranged on the front plate of the CPU module:

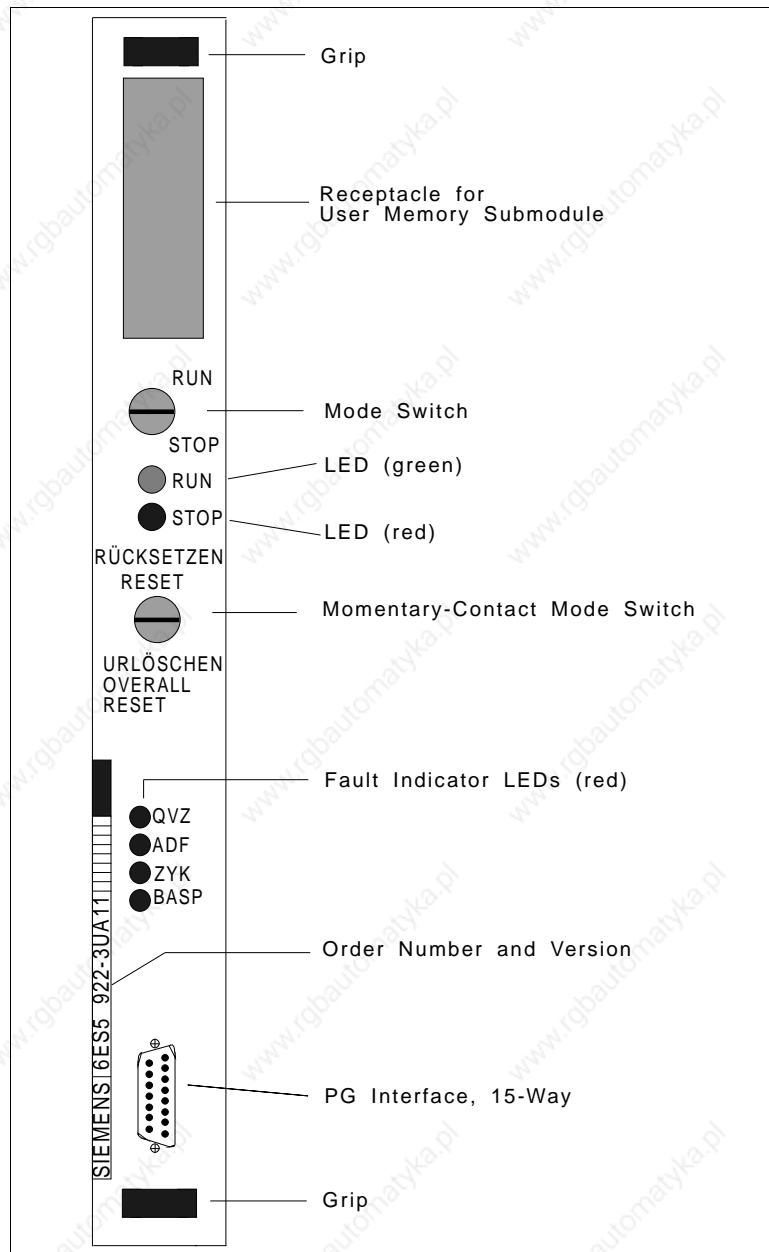

Figure 5-5 Front Plate of the CPU 922

<i>Mode switch</i>	The mode switch has two settings:
<i>RUN</i>	In the RUN setting, the CPU 922 processes the user program when the green RUN LED is lit.
<i>STOP</i>	The CPU 922 goes to the stop state when you switch from RUN to STOP. The red STOP LED then lights up.
<i>Momentary-contact mode switch</i>	You can initiate the Overall Reset, Reset and Restart functions with the momentary-contact mode switch:
<i>OVERALL RESET</i>	<p>Momentary-contact switch down</p> <p>With an overall reset, all RAM areas are erased and initialized (both on the CPU and on a RAM submodule).</p>
<i>RESET</i>	<p>Momentary-contact switch up</p> <p>During a reset, all flags, timers, counters and the process image will be erased. OB 20 will be invoked. Processing of the user program will start from the beginning again.</p>
<i>Restart</i>	<p>Momentary-contact switch at midpoint</p> <p>With a restart, processing of the user program will continue from the point of interruption. The statuses of flags, timers, counters and the process image are retained during stoppage of the CPU.</p>

## Status indicators

<b>RUN LED</b>	<b>STOP LED</b>	<b>Status</b>
on	off	The CPU is in the RUN state.
off	on	The CPU is in the STOP state. After a stop request by switch or PG function, the STOP LED is continuously lit because the transition to the STOP state was requested by the user or, in multiprocessor operation by another CPU, and was not caused by the CPU itself.
off	off	The CPU is in the INITIAL START or program check state.
off	slow flashing	The CPU is in the STOP state. The CPU has caused a transition to the STOP state (possibly also for the other CPUs). If you set the mode switch to STOP, the flashing LED becomes continuously lit.
off	rapid flashing	The CPU is in the STOP state. An overall reset has been requested. This request can be initiated by the CPU itself or by operator action.

### LEDs for fault indication and signalling

<b>QVZ LED</b>	
on	<p>During direct access or process image update, a module addressed by the program no longer acknowledges although</p> <ul style="list-style-type: none"> <li>• <i>either</i> it has acknowledged in single processor operation upon reset of the CPU 922 in the area of the process image (IB 0 to 127, QB 0 to 127) and has been entered as present in the "9th track" (see Programming Guide, CPU 922),</li> <li>• <i>or</i> it has been entered in DB 1 (address list) in multiprocessor or single-processor operation and has been recognized as present during the reset.</li> </ul> <p><b>Possible causes</b></p> <ul style="list-style-type: none"> <li>• Module failure.</li> <li>• Module was pulled out during operation, in the STOP state or in the Off state without a subsequent reset.</li> </ul>
<b>ADF LED</b>	
on	The user program has referenced an I/O address in the process image under which no module is inserted.
<b>ZYK LED</b>	
on	The maximum cycle time has been exceeded.
<b>BASP LED</b>	
on	Command output is inhibited and the digital outputs will be directly switched to the safe state.

A detailed description of interrupt and error handling can be found in the CPU 922 Programming Guide.

**Startup**

The modules must be inserted at the correct slots in the central controller. The backup battery must be fitted and in order for the CPU to start.

**Overall reset**

Step	Action	Result
1	Set the mode switch to STOP.	
2	Switch the system voltage on.	The following LEDs must light up on the CPU: - Red STOP LED (flashing rapidly) - Red BASP LED
3	Hold the MC <sup>1)</sup> switch in the OVERALL RESET setting and simultaneously set the mode switch from STOP to RUN.	The red STOP LED is now permanently lit.

<sup>1)</sup> MC: Momentary-contact

**Reset**

Step	Action	Result
4	Set the mode switch to STOP.	
5	Hold the MC switch in the RESET setting and simultaneously set the mode switch from STOP to RUN.	- Red STOP LED goes off - Green RUN LED lights up - Red BASP LED goes off The CPU is now in the RUN state but still has no user program.

**Restart**

You can also carry out a manual restart of the CPU 922 with the mode switch. The CPU 922 Programming Guide will indicate when a manual restart is permissible.

Step	Action	Result
1	Set the mode switch from STOP to RUN.	- Red STOP LED goes off - Green RUN LED lights up - Red BASP LED goes off

For maintenance purposes or in the event of a fault, this startup without user program in single-processor operation can serve to establish whether the CPU is operating without errors.

### 5.4.3 Technical Specifications

#### Important for the USA and Canada

The following approvals have been obtained:



UL Listing Mark  
Underwriters Laboratories (UL) to  
Standard UL 508, Report E 85972



CSA Certification Mark  
Canadian Standard Association (CSA) to  
Standard C 22.2 No. 142, Report LR 63533

Type of protection	IP 00				
Climatic ambient conditions	See Technical Specifications of the S5-135U/155U CC				
Mechanical ambient conditions	See Technical Specifications of the S5-135U/155U CC				
Noise immunity, electromagnetic compatibility (EMC)	See Technical Specifications of the S5-135U/155U CC				
Supply voltage	5 V $\pm$ 5 %				
Current consumption at 5 V	2.2 A typical				
Backup voltage	3.4 V				
Backup current without user RAM submodule	20 $\mu$ A typical (at 25 °C)				
	P area	O area	IM3 area	IM4 area	Total
Digital inputs with process image	1024 max.	–	–	–	1024 max.
Digital inputs without process image or analog inputs	1024 max. 64 max.	2048 max. 128 max.	2048 max. 128 max.	2048 max. 128 max.	7168 max. 448 max.
Digital outputs with process image	1024 max.	–	–	–	1024 max.
Digital outputs without process image or analog outputs	1024 max. 64 max.	2048 max. 128 max.	2048 max. 128 max.	2048 max. 128 max.	7168 max. 448 max.
Flags	2048				
Timers	128				
Counters	128				
Size of user memory	max. of 64 K words, EPROM or RAM				
DB RAM	22 Kbytes				
Transmission rate of serial PG interface	9600 bit/s				
Program blocks PB	256				
Sequence blocks SB	256				
Function blocks FB	256				
Function blocks FX	256				

Data blocks DB	256, of which 253 are freely available
Data blocks DX	256, of which 253 are freely available
Organization blocks OB	OB 1 to 39 (interfaces for operating system)
Integrated special function organization blocks OB	See Pocket Guide
Dimensions (w x h x d)	20.32 x 233.4 x 160 mm
Weight	Approx. 0.5 kg

## 5.5 374 Flash EPROM Cards

This section provides a summary

- of the use of the 374 flash EPROM cards (known as the 374 memory cards in the following) in the CPU 948,
- and of the technical specifications.

### 5.5.1

#### Technical Description

The 374 memory card serves as a storage medium for user programs and user data. It contains electrically erasable flash EPROMs.

The 374 memory card is available in the following capacities:

- 256 Kbytes
- 512 Kbytes
- 1024 Kbytes
- 2048 Kbytes
- 4096 Kbytes

**5**

#### *Ordering information*

The order numbers for the SIMATIC S5 memory cards can be found in the ordering information.

### 5.5.2

#### Notes on Operation

##### *Programming a memory card*

You can program and erase the 374 memory card off-line on the SIMATIC S5 programmers. The link to the PG is provided by a special connector or programming adapter, into which the memory card is inserted. A description of EPROM programming can be found in the STEP 5 manual.

##### *Inserting and removing a memory card*

Memory cards can be inserted and removed at any time, even whilst the CPU is running, as long as they are not being accessed (see the CPU 948 Programming Guide).

##### *Loading data*

The contents of the memory cards are only copied automatically into the internal RAM of the CPU upon overall reset of the CPU.

##### *Erasing a memory card*

Memory cards are electrically erasable.



### 5.5.3 Technical Specifications

#### Important for the USA and Canada

The following approvals have been obtained:



UL Listing Mark  
Underwriters Laboratories (UL) to  
Standard UL 508, Report E85972



CSA Certification Mark  
Canadian Standard Association (CSA) to  
Standard C 22.2 No. 142, Report LR 63533

Supply voltage during a read operation	+5 V $\pm$ 5 %
Current consumption during a read operation (at 5 V)	200 mA max.
Access time $t_{ACC}$	200 ns
Operating temperature	0 to 55 °C
Storage temperature	0 to 60 °C
Relative humidity	Up to 95 % at 25 °C, no condensation
Number of programming cycles	10,000
Dimensions (H x D x W)	54 x 85 x 5 mm
Weight	Approx. 50 g

## 5.6 376 Memory Submodules

This section provides a summary

- of the use of the 376 memory submodules in the 928B, 928 and 922 CPUs,
- and of the technical specifications.

### 5.6.1

#### Technical Description

The 376 memory submodules serve as a storage medium for user programs and user data. They contain UV-erasable CMOS EPROMs.

376 memory submodules are available in the following capacities:

- 16 Kbytes
- 32 Kbytes
- 64 Kbytes

**5**

#### Ordering information

The order numbers for the SIMATIC S5 memory submodules can be found in the ordering information.

### 5.6.2

#### Notes on Operation

##### *Programming the memory submodules*

You program the 376 memory submodules off-line on the SIMATIC S5 programmers. The link to the PG is provided by the EPROM programming interface integrated in the PG. A description of EPROM programming can be found in the STEP 5 manual. Use an adhesive label to cover the EPROM window (erasing window) after programming.



#### **Caution**

CMOS memory submodules are destroyed by programming with the wrong programming number. A list of valid order nos. (MLFBs) and programming numbers can be found in your STEP 5 software in the EPROM package.

*Inserting a memory submodule*

Before inserting a 376 memory submodule in the module receptacle of the CPU,

- set the CPU mode switch to STOP
- and switch off the PLC (Power Off).

*Erasing a memory submodule*

376 memory submodules can be erased with a UV eraser. Before erasing, remove the plastic cover and the adhesive label from the erasing window.

**5.6.3  
Technical Specifications**

**Important for the USA and Canada**

The following approvals have been obtained:



UL Listing Mark  
Underwriters Laboratories (UL) to  
Standard UL 508, Report E 85972



CSA Certification Mark  
Canadian Standard Association (CSA) to  
Standard C 22.2 No. 142, Report LR 63533

Supply voltage during a read operation	+5 V ± 5 %
Current consumption during a read operation (at 5 V)	200 mA max.
Access time $t_{ACC}$	250 ns
Operating temperature	0 to 55 °C
Storage temperature	- 40 to 70 °C
Relative humidity	Up to 95 % at 25 °C, no condensation
Dimensions (H x D x W)	55 x 58 x 14 mm
Weight	Approx. 40 g

## 5.7 377 Memory Submodules

This section provides a summary

- of the use of the 377 memory submodules in the 928B, 928 and 922 CPUs,
- and of the technical specifications.

### 5.7.1

#### Technical Description

377 memory submodules (RAM submodules) are available with or without battery backup in the following capacities:

Without Battery Backup	With Battery Backup
16 Kbytes	64 Kbytes
32 Kbytes	
64 Kbytes	

5

The order numbers for the 377 memory submodules can be found in the ordering information.

### 5.7.2

#### Notes on Operation

##### *Loading RAM submodules*

377 memory submodules are loaded online (from the PG) in the CPU. A description of loading the individual submodules or the entire program can be found in the STEP 5 manual.

### 5.7.3 RAM Submodules with Battery Backup

RAM submodules with battery backup are used when the contents of the memory submodules must be retained even outside the CPU. You can then remove the battery-backed 377 memory submodule from the CPU without loss of data. An integral battery protects the submodule from data loss, and ensures that the data will be retained until the RAM submodule is used again.

#### Note

The RAM submodule with battery backup is not a substitute for an EPROM submodule. The contents can be overwritten by a STEP 5 program. The battery can discharge if the submodule is at standby for a long time. This can result in the loss of data.

To protect the battery, the 377 memory submodule has a cover on both sides. The button cell battery with terminal lugs is secured on the submodule with screws on two holders. When the grip is swivelled in, you can see the battery fault LED.

### Operational states

There are three different operational states for the RAM submodule with battery backup:

#### Normal operation

In this state

- the battery-backed RAM submodule is in the CPU;
- the programmable controller (PLC) is switched on (Power On);
- and neither the backup battery of the PLC nor the battery of the RAM submodule is supplying power.

#### Note

The RAM submodule must not be inserted or removed during the RUN state; this can result in data corruption, loss of data or CPU malfunctions.

**Standby operation**

In this standby state of the unit

- the battery-backed RAM submodule is in the CPU;
- the PLC is switched off (Power Off);
- the backup battery of the PLC is providing backup of the RAM submodule;
- the submodule battery is not supplying power.

**Note**

It is only possible to insert and remove the RAM submodule in this state without data corruption.

If the backup battery in the PLC fails in this state, the submodule battery provides backup of the RAM submodule. This prevents loss of data.

**5****Submodule standby**

In this standby state of the submodule

- the RAM submodule has been removed from the CPU;
- the submodule battery is providing backup of the RAM submodule;
- the contents of the battery-backed RAM are retained.

**Battery monitoring and battery fault**

The battery of the battery-backed RAM submodule is monitored. When the RAM submodule goes to normal operation (battery-backed RAM is in the CPU, supply voltage of the PLC is switched on), the battery monitor on the submodule detects the following faults:

- Submodule battery is not present.
- Submodule battery is faulty (voltage less than 2.6 V).

The red battery fault LED on the front of the submodule is continuously lit.

**Note**

A temporary voltage drop of the submodule battery in the standby state, e.g. caused by storage below 0 °C or a battery change, is not detected by the battery monitor if the voltage dip is corrected by plugging in the RAM submodule and switching on the PLC. However, the voltage dip may have led to a loss or corruption of RAM submodule data.

**Inserting or replacing the backup battery**

Before the RAM submodule with battery backup is started for the first time, you must insert the battery provided. This is delivered separately to protect it from premature discharge. Proceed according to the following steps:

Step	Action
1	Open the upper side of the cover by releasing the snap-on catch. Grasp the cover within the clearance from the PCB and pull it up.
2	Insert the submodule battery and secure it with a screw on the left and on the right. Ensure correct polarity (+/-).
3	Close the cover again.

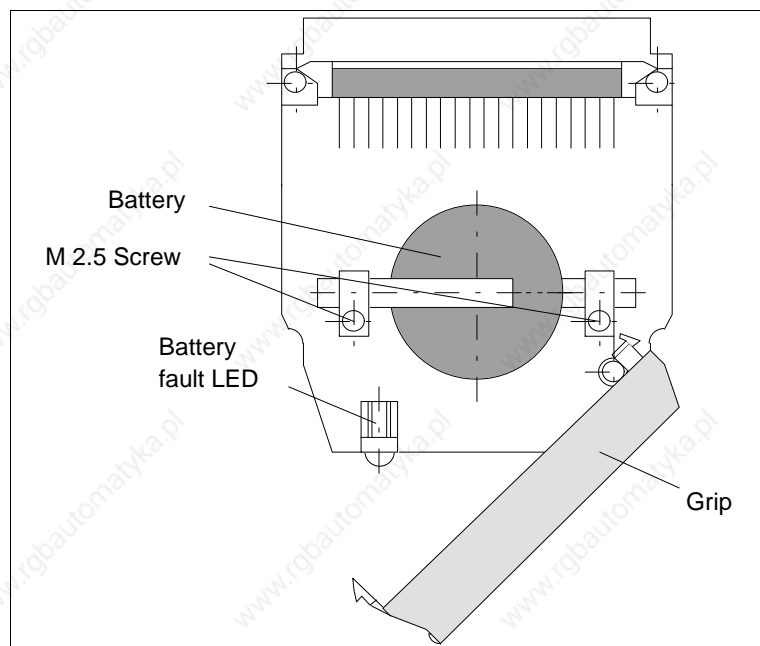

Figure 5-6 Mounting Location for Backup Battery

**Caution**

Improper replacement of the battery can result in explosion hazard. It should only be replaced by the same type or an equivalent one recommended by the manufacturer. Used batteries should be disposed of according to the manufacturer's instructions.

Proceed as follows to replace the submodule battery:

Step	Action
1	Open the upper side of the cover by releasing the snap-on catch.
2	Slacken the screws on the left and right of the battery.
3	Replace the submodule battery and secure the new battery with screws, observing the polarity.
4	Close the cover again.

### Using the RAM submodule with battery backup



#### Caution

EPROM-Battery-backed RAM submodules must not be programmed via the EPROM interface of the PG, otherwise they can be destroyed.

Before inserting or removing the RAM submodule into or out of the CPU, switch the PLC power supply off: this is to ensure that data of the RAM submodule are not corrupted.

### Inserting unprogrammed memory submodules

Initial situation:

- The CPU is in the programmable controller.
- The power supply of the PLC is switched off.
- The mode switch of the CPU is at STOP.

Step	Action
1	First insert the battery in the RAM submodule.
2	Insert the RAM submodule in the CPU.
3	Switch the power supply of the programmable controller on.
4	Carry out an overall reset.
5	Connect your programmer (PG) to the CPU.
6	When the user program has been loaded into the RAM submodule, reset the CPU.



**Inserting programmed memory submodules**

Since the contents of the inserted RAM submodule are erased with each overall reset, proceed as follows when using programmed RAM submodules whose contents are not to be erased:

Initial situation:

- The CPU is in the programmable controller.
- The power supply of the PLC is switched off.
- The mode switch of the CPU is at STOP.

Step	Action
1	Insert another, unprogrammed memory submodule in the CPU.
2	Switch the power supply on.
3	Carry out an overall reset.
4	Switch the power supply off.
5	Remove the unprogrammed memory submodule.
6	Insert the programmed memory submodule.
7	Switch the power supply on.
8	Carry out a reset.

**Removing memory submodules**

Before removing the RAM submodule, check whether the battery is still in order: if the battery fault LED on the RAM submodule is lit whilst the PLC supply voltage is switched on, the contents of the RAM submodule will be lost when it is removed.

Initial situation:

- The CPU is in the RUN state.

Step	Action
1	Set the CPU mode switch to STOP.
2	Switch the power supply off.
3	Remove the memory submodule.

#### 5.7.4 Technical Specifications

##### Important for the USA and Canada

The following approvals have been obtained:



UL Listing Mark  
Underwriters Laboratories (UL) to  
Standard UL 508, Report E85972



CSA Certification Mark  
Canadian Standard Association (CSA) to  
Standard C 22.2 No. 142, Report LR 63533

All 377 memory submodules

Supply voltage	+5 V ± 5 %
Operating temperature	0 to 55 °C
Storage temperature	- 40 to 70 °C
Relative humidity	Up to 95 % at 25 °C, no condensation
Dimensions (H x D x W), short type	55 x 58 x 14 mm
Weight	Approx. 40 g / 60 g

5

Submodules without  
battery backup

Current consumption (at 5 V)	100 mA max. (16/64 Kbytes) 200 mA max. (32 Kbytes)
Backup current/standby	Approx. 20 µA typ. (16/64 Kbytes) Approx. 40 µA typ. (32 Kbytes)
Backup voltage/ UCMOS	2.7 to 3.6 V
Access time $t_{ACC}$	150 ns (16/64 Kbytes) 200 ns (32 Kbytes)

### Submodules with battery backup

Current consumption (at 5 V)	140 mA max.
Backup current	13 $\mu$ A typ.
Backup voltage/UCMOS	2.7 to 3.6 V
Submodule battery	Lithium button cell 3 V/200 mAh Type CR 2430 (LF-1/2W) from VARTA
Backup time	1 year min. at 25 °C
Access time $t_{ACC}$	150 ns

## 5.8 Interface Submodules

The second serial interface of the CPU 928B can be optionally used as:

- A PG interface (for PG and operator panels)
- An interface for the RK 512 computer link
- An interface for data transmission with procedures 3964/3964R
- An interface for data transmission with the "open driver"
- An interface for data transmission via the SINEC L1 bus (from Version 6ES5 928-3UB12)

The second serial interface of the CPU 948 can be used as:

- A PG interface (for PG and operator panels)

*Using the interface submodules*

5

To use the second interface as...	you require
a PG interface	the PG submodule
an interface for data transmission with RK 512 computer link, procedures 3964/3964R or "open driver"	the V.24 (RS 232C) or TTY or RS 422 A/485 submodule (only in RS 422 A mode)
an interface for data transmission via the SINEC L1 bus	the SINEC L1 submodule



**Removal**

Remove your interface submodule in the following steps:

Step	Action
1	Switch off the power supply of your PLC.
2	Remove the CPU from the central controller.
3	Slacken the two locking screws of the submodule and pull it out of the receptacle.
4	Fit another submodule (as already described) or close the receptacle with its cover. Use the fixing screws of the submodule.
5	Insert the CPU in the central controller.
6	Switch the power supply of your PLC on again.

**Note**

Since the interface module is secured to the CPU with screws, interference pulses are given a path to ground via the shield of the CPU. The CPU should only be operated with the submodule receptacle closed (by a cover or submodule).

**5.8.2  
PG Submodule**

By means of the PG submodule, you can use the second interface of the CPU as the PG interface and equally privileged with the first interface.

**Application**

The PG submodule can be inserted in the following CPUs:

Interface Submodule	For Use With
PG submodule	CPU 928B CPU 948

**Circuitry**

The PG submodule is equipped with a transmitter and a receiver for 20 mA current loop signals. The loop current is always fed in from the PG. The following figure shows the circuitry for current loop signals of the standard cable:

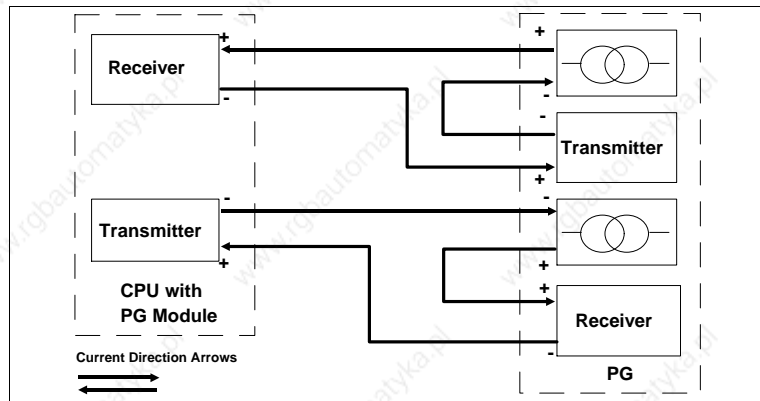

Figure 5-7 PG Submodule: Loop Current Direction

**Data transmission rate**

The rate for data transmission via the PG interface is always 9600 baud.

**Pin assignments of the PG submodule**

Given in the following table are the pin assignments of the 15-pin subminiature D-type connector in the front plate of the PG submodule:

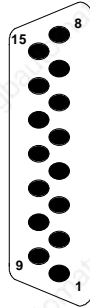

Pin	Designation	Current Direction	Remarks
1	Housing/GND/GND <sub>ext</sub>		
2	- RxD	→	
3	VPG + 5 V <sub>-</sub>		
4	+24 V from bus		
5	0 V GND/GND <sub>int</sub>		
6	+ TxD	←	
7	- TxD	→	
8	Housing/GND/GND <sub>ext</sub>		
9	+ RxD	←	
10	24 V GND	←	Current return
11	20 mA	→	Current source, transmitter
12	0 V GND/GND <sub>int</sub>		
13	20 mA	→	Current source, receiver
14	VPG + 5 V <sub>-</sub>		
15	0 V GND/GND <sub>int</sub>		

↑ : From partner to CPU

→ : From CPU to partner



**Jumper settings on the PG submodule**

When the PG submodule is delivered, the jumpers are set as shown in the following figure. As a rule, therefore, you can use the PG submodule immediately.

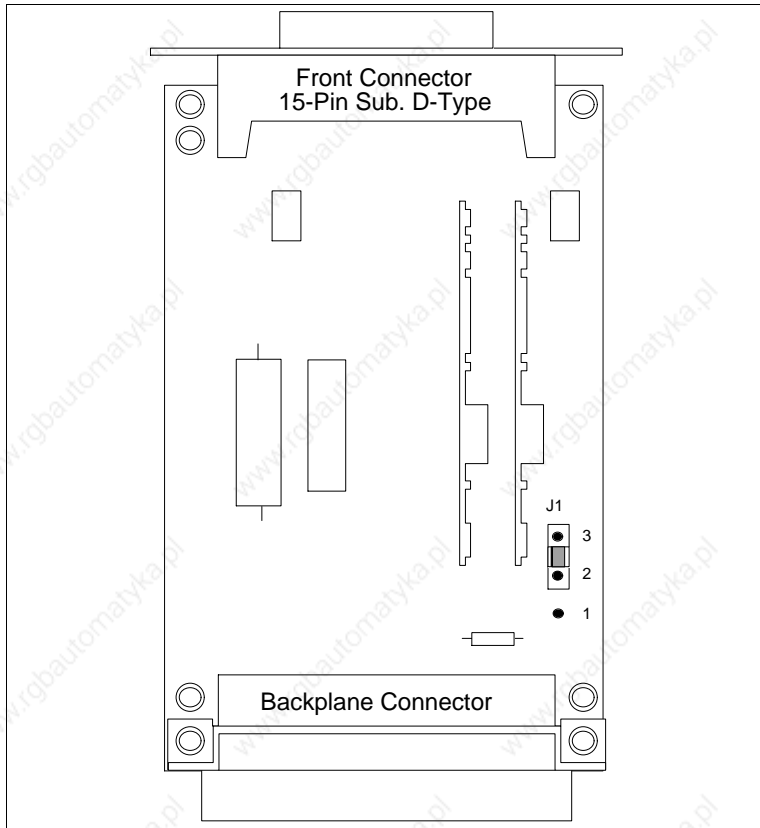
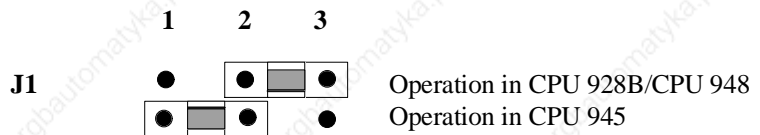

Figure 5-8 PG Submodule: Jumper Settings when Delivered

**J1** is set to select whether the PG submodule is to be operated in the CPU 928B/CPU 948 or in the CPU 945:



**Standard connecting cable for the PG submodule**

Standard cables for connecting the PG submodule in the CPU to the PG are available from Siemens in various lengths, up to 1000 m.

Order numbers and lengths can be found in the ordering information.

**Connecting cable: CPU - PG**

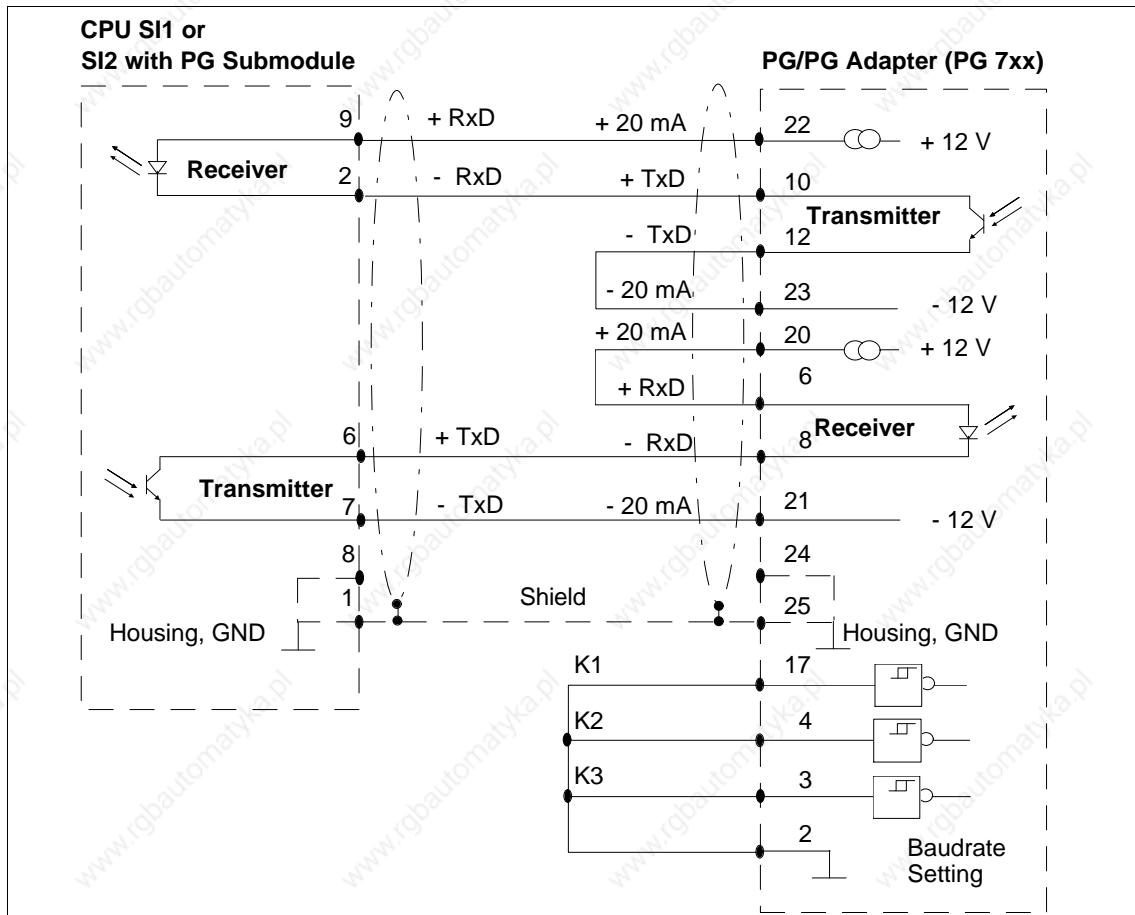

5

Figure 5-9 PG Submodule: Standard Connecting Cable

**5.8.3  
V.24 Submodule**

The V.24 submodule is used with the RK 512 computer link, data transmission with procedures 3964/3964R, data transmission with the "open driver".

**Application**

The V.24 submodule can be inserted in the following CPU:

Interface Submodule...	For Use With...
V.24 submodule	CPU 928B

**Circuitry**

The following figure shows the circuitry for the V.24 interface (transmit and receive lines):

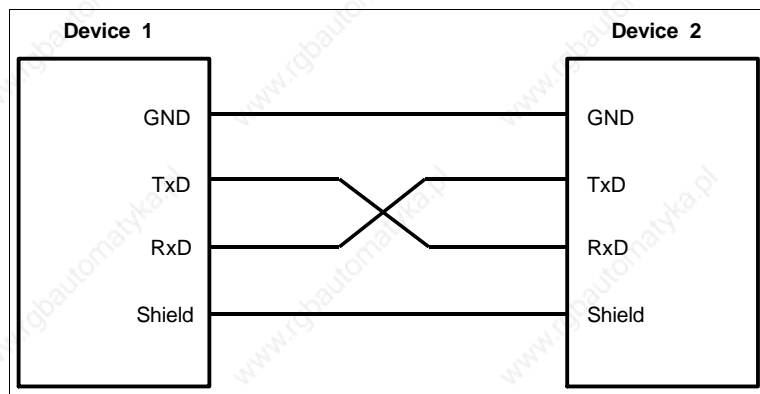

Figure 5-10 V.24 Interface

Apart from the transmit and receive lines, the V.24 submodule has a number of control and signalling lines to CCITT Recommendation V.24/V.28. However, these control signals are not needed and not used for the standard procedures of communication types RK 512, 3964/3964R and "open driver". (Exception: RTS/CTS with the "open driver").

The following applies to V.24 signals:

Logic 0 is represented by a voltage  $U \geq +3V$

Logic 1 is represented by a voltage  $U \leq -3V$

If you fabricate the connecting cables yourself, note that unused inputs at the partner station may have to be connected to quiescent potential. Further details can be found in the appropriate manuals and in CCITT Recommendations V.24/V.28.

**Data transmission rate**

A maximum of 19200 baud is permissible for data transmission with the V.24 submodule.

### Pin assignments of the V.24 submodule

The following table shows the pin assignments of the 25-pin subminiature D-type connector in the front plate of the V.24 submodule:

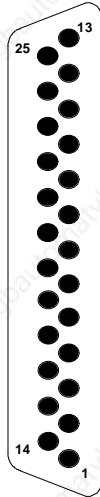

Pin	Des. to DIN 66020	Des. to CCITT V.24	Int. Abbreviation	Input/Output	Remarks
1			Shield		
2	D1	103	TxD	Output	
3	D2	104	RxD	Input	
4	S2	105	RTS	Output	
5	M2	106	CTS	Input	
6	M1	107	DSR	Input	
7	E2	102	GND		
8	M5	109	DCD	Input	
18	PS3	141		Output	Not supported
20	S1.2	108.2	DTR	Output	
22	M3	125	RI	Input	
23	S4	111		Output	
25	PM1	142		Input	Not supported

The signal numbering complies with DIN 66020 (V.24/RS 232C); the signal designations are the abbreviations used internationally (RS 232C).

**Jumper settings of the V.24 submodule**

When the V.24 submodule is delivered, the jumpers are set as shown in the following figure. As a rule, you can therefore use the V.24 submodule immediately.

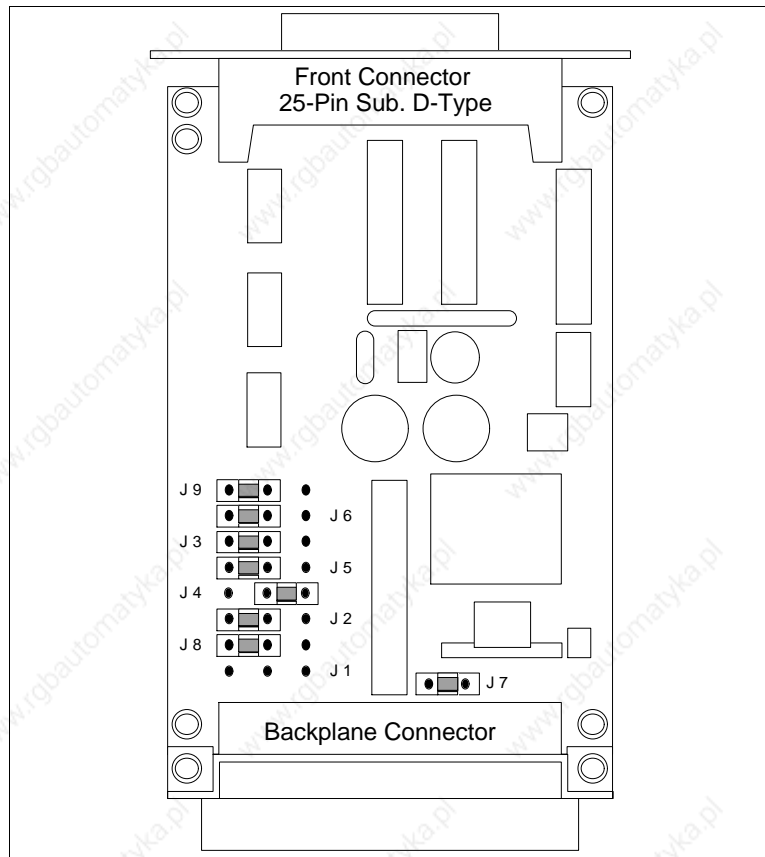
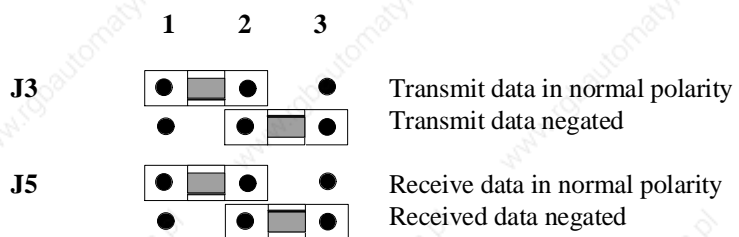
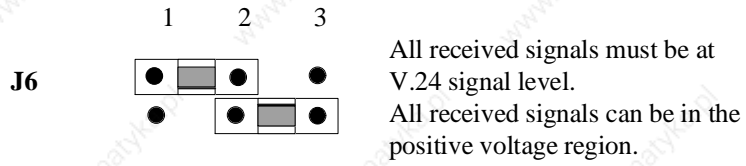

Figure 5-11 V.24 Submodule: Jumper Settings when Delivered

You can change over the polarity of the transmit and receive data with jumpers **J3** and **J5**.



With jumper **J6**, you can set all V.24 receivers so that you only require positive-going signals (positive voltage region).



With jumper **J9**, CTS can be set permanently to quiescent potential, i.e. switched through from the front connector.

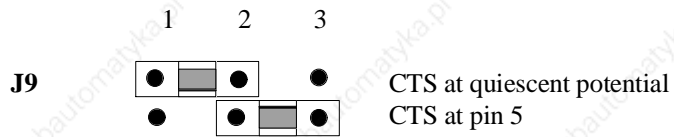

**Standard connecting cables of the V.24 submodule**

Standard cables for connecting the V.24 submodule of the CPU to the partner station are available from Siemens in various lengths, up to 16 m.

Order numbers and lengths can be found in the ordering information.

**Connecting cable for CPU, CP 524, CPU 525, CP 544**

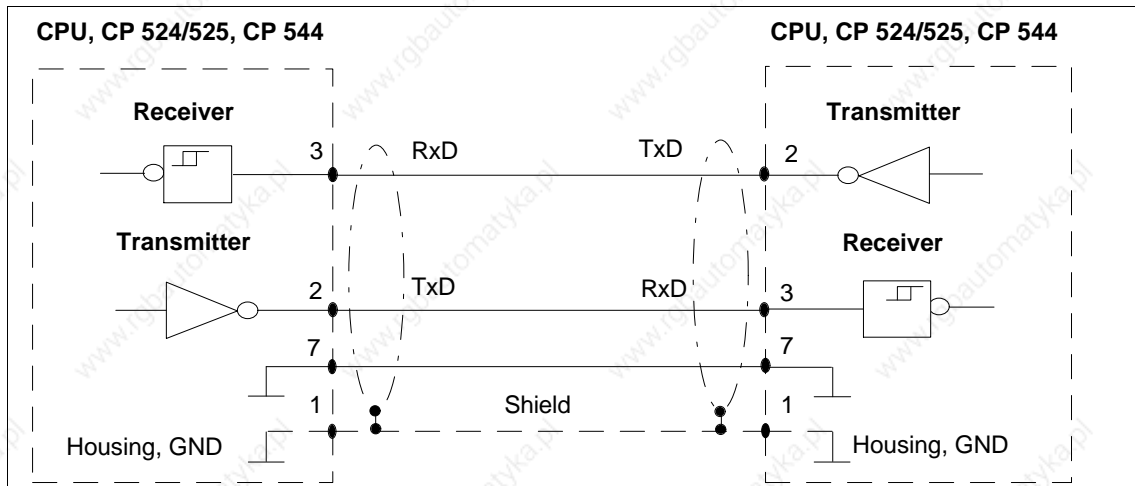

Figure 5-12 V.24 Submodule: Connecting Cable for CPU, CP 524, CP 525, CP 544

Connecting cable: CPU - N10 modem

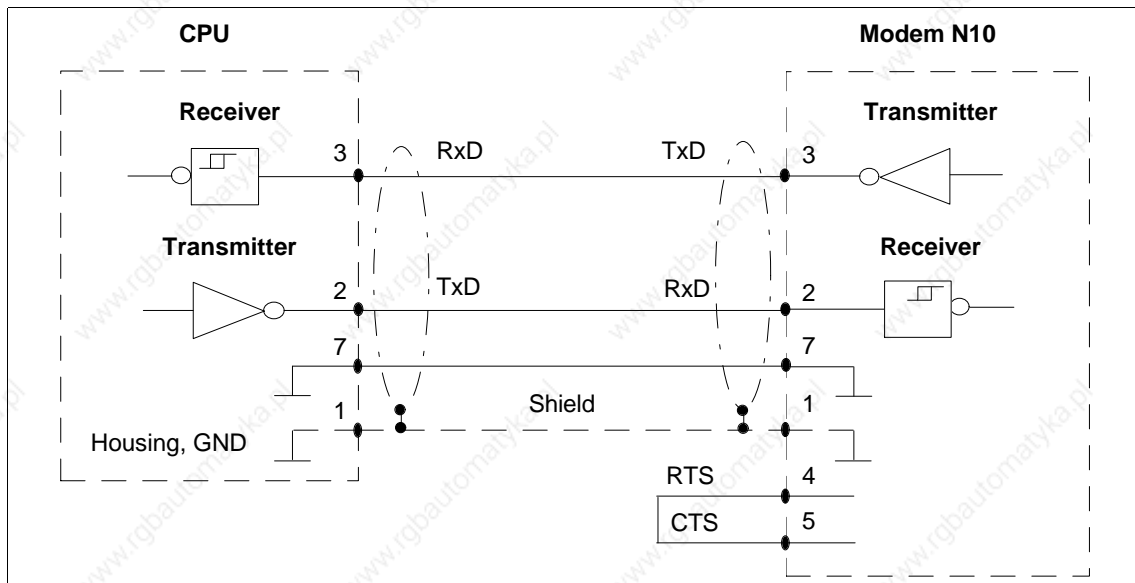
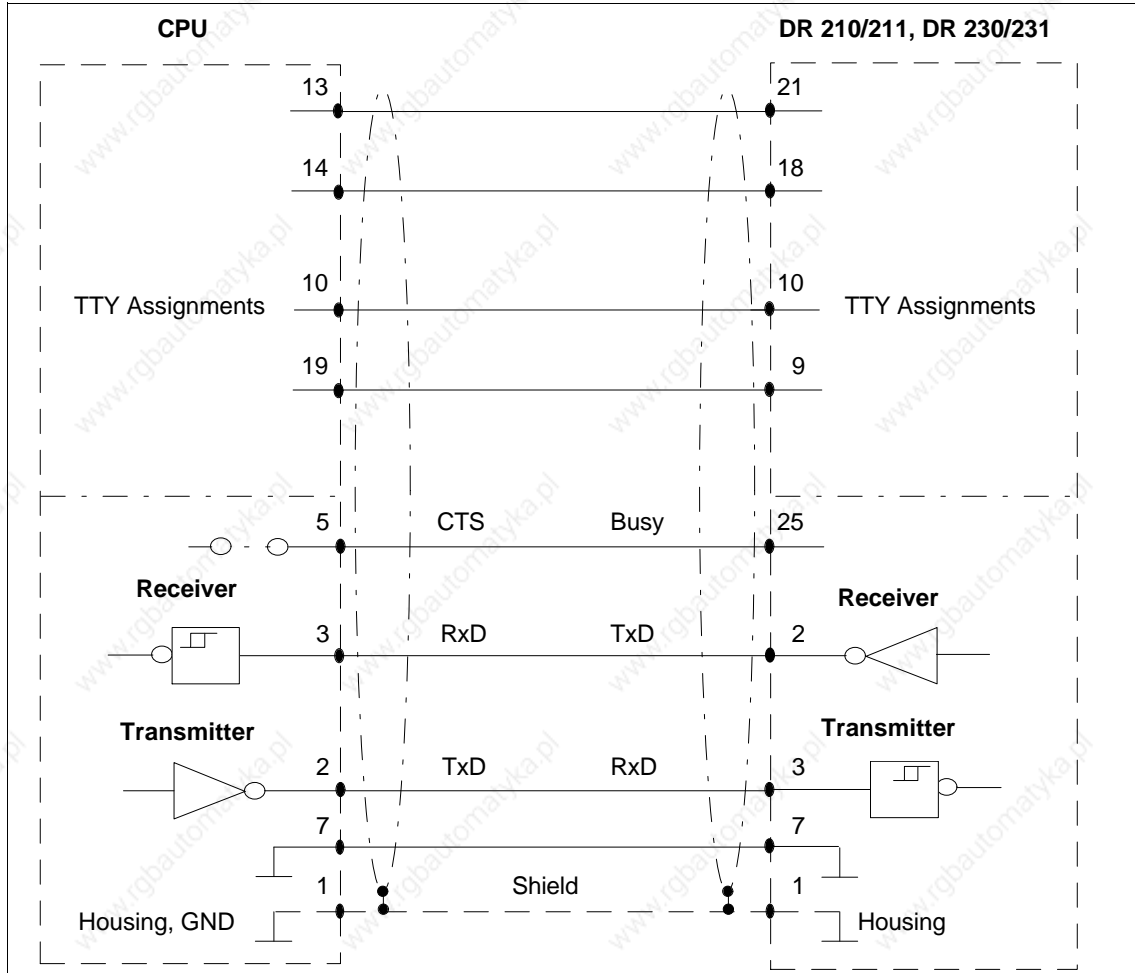

Figure 5-13 V.24 Submodule: Connecting Cable for CPU - N10 Modem

**Connecting cable: CPU - DR 210/211, DR 230/231**

You can use this connecting cable both with the V.24 and with the TTY submodule. Ensure that you have the same type of interface in the CPU and in the printer.



5

Figure 5-14 V.24 Submodule: Connecting Cable for CPU - DR 210/211, DR 230/231



Wiring of a connecting cable for RTS/CTS flow control

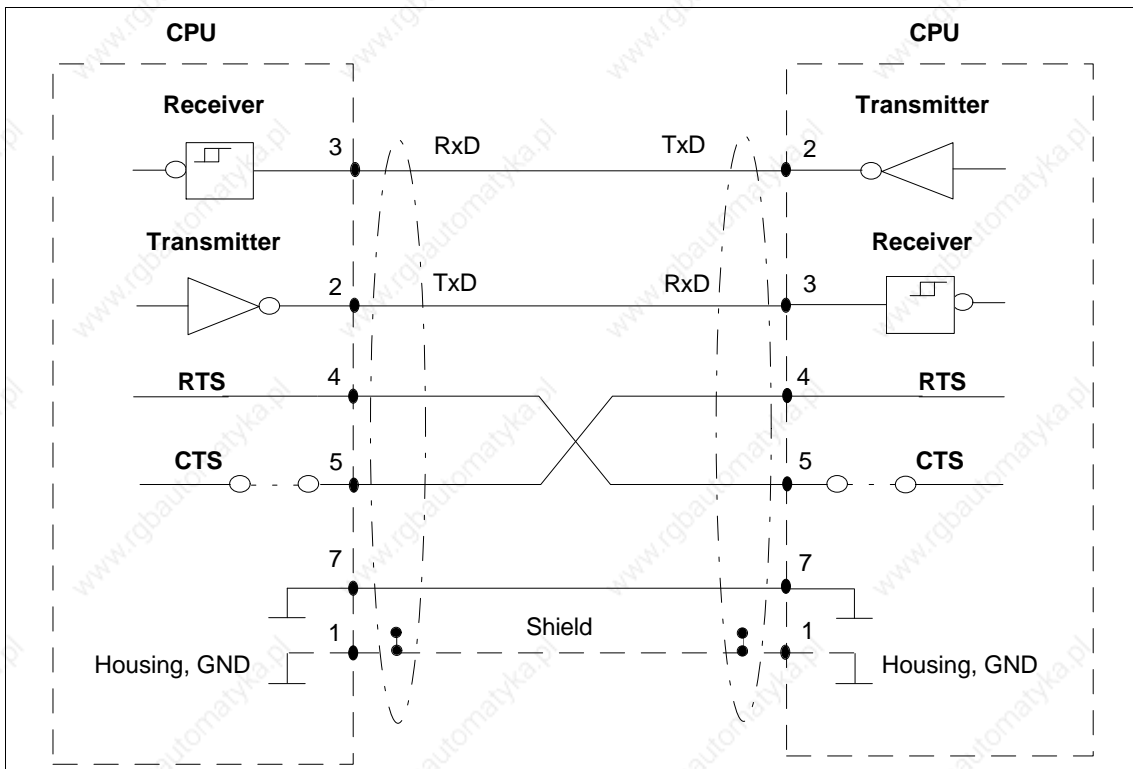

Figure 5-15 Example of a Connecting Cable: CPU - CPU for RTS/CTS Flow Control

### 5.8.4 TTY Submodule

The TTY submodule is for use with the RK 512 computer link, data transmission with procedures 3964/3964R, data transmission with the "open driver".

The TTY submodule complies with DIN 66 258, Part 1.

#### Application

The TTY submodule can be inserted in the following CPU:

Interface Submodule...	For Use With...
TTY submodule	CPU 928B

#### Circuitry

The TTY submodule is equipped with a transmitter and receiver for 20 mA current loop signals. Shown in the following figure is the typical circuitry for current loop signals.

5

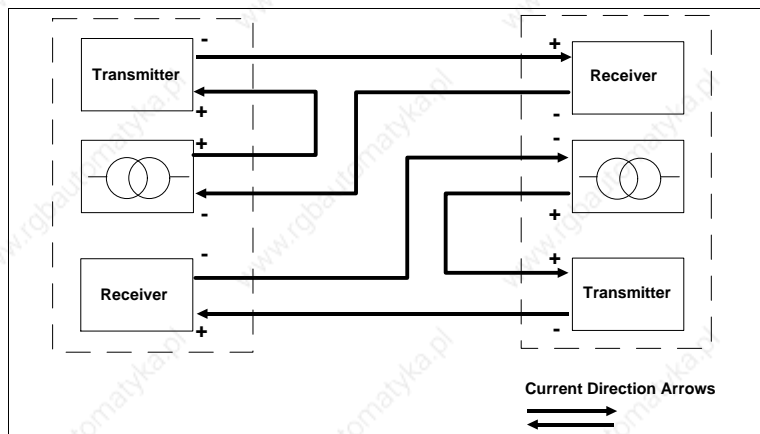

Figure 5-16 TTY Submodule: Loop Current Direction

The loop current can be fed in both by the TTY submodule and by the partner station. Only the side supplying the current is non-floating.



#### Caution

With longer line lengths, you should arrange your line so that the transmitter always supplies the current.

The TTY submodule feeds in the current (20 mA) via jumpers in the connector of the standard connecting cable. The 24 V required for generation of loop current is taken from the power supply of the PLC. In the quiescent state, with a correct loop current connection, there should be a flow of 20 mA (= logic 1). When the current is interrupted there is a logic 0.

The following applies to the TTY signals:

Logic 0 is represented by: no current

Logic 1 is represented by: current (20 mA)

**Data transmission rate**

A maximum of 9600 bps is permissible for data transmission with the TTY submodule.

**Pin assignments of the TTY submodule**

Shown in the figure are the pin assignments of the 25-pin subminiature D-type connector in the front plate of the TTY submodule:

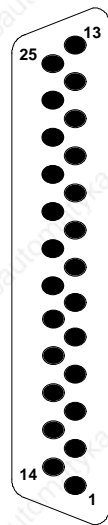

Pin	Designation	Current direction	Remarks
1	Shield		
9	24 V external		This connection is changed over between 24 V internal and 24 V external with jumper J3 (see next page).
10	+ TxD	←	
12	+ 20 mA	→	Current source, transmitter
13	+ RxD	←	
14	- RxD	→	
16	+ 20 mA	→	Current source, receiver
19	- TxD	→	
21	- 20 mA	←	Current return
24	- 20 mA	←	Current return

← : Input

→ : Output

**Jumper settings on the TTY submodule**

When the TTY submodule is delivered, the jumpers are set as shown in the following figure. As a rule, therefore, you can use the TTY submodule immediately.

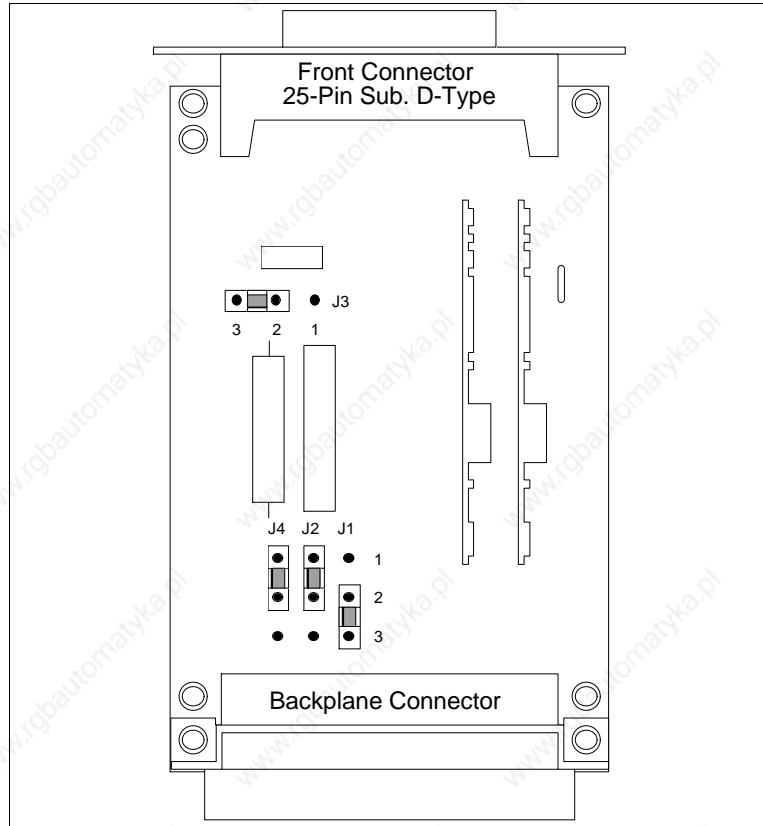

5

Figure 5-17 TTY Submodule: Jumper Settings when Delivered

The polarity of the transmit and receive data is changed over with jumpers **J1** and **J2**:

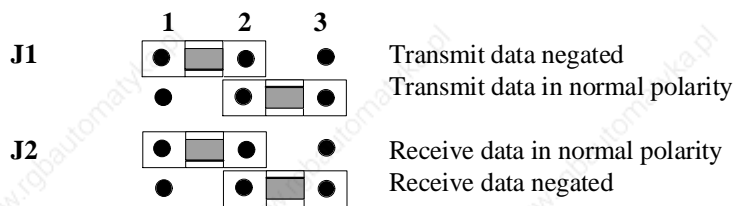

The 24 V source voltage for generation of the loop current can be allocated with jumper **J3**:

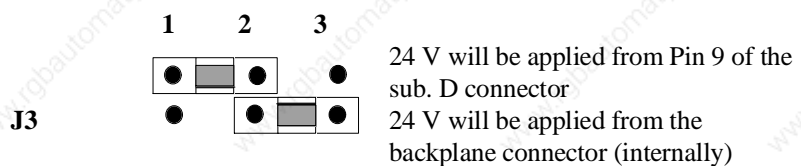

**Standard connecting cables for the TTY submodule**

Standard cables for connecting the TTY submodule in the CPU to the partner station are available from Siemens in various lengths, up to 1000 m.

Order numbers and lengths can be found in the ordering information.

**Connecting cable for CPU, CP 524, CP 525, CP 544**

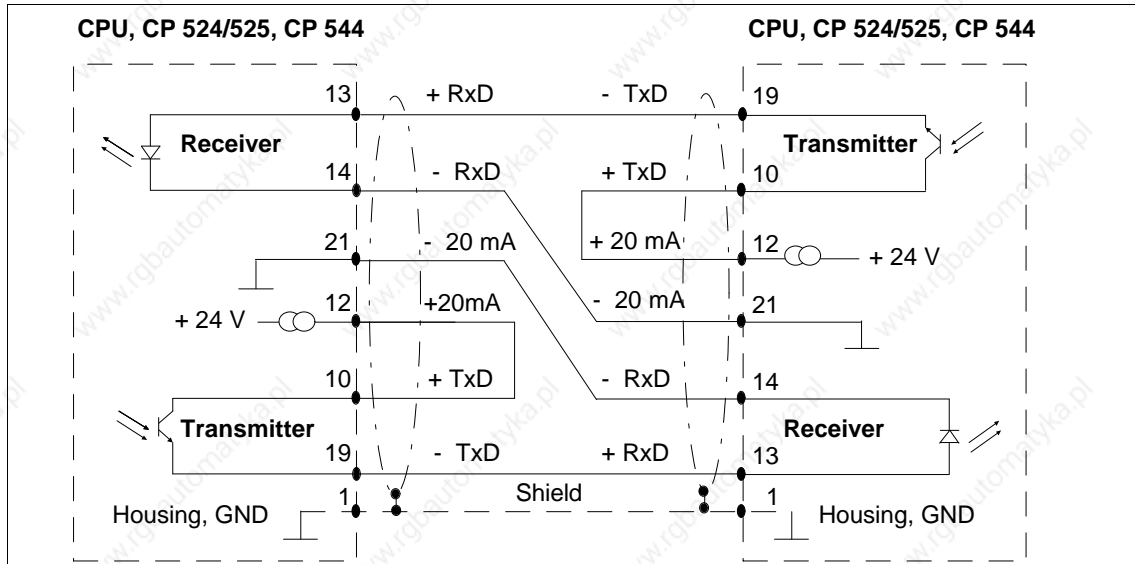
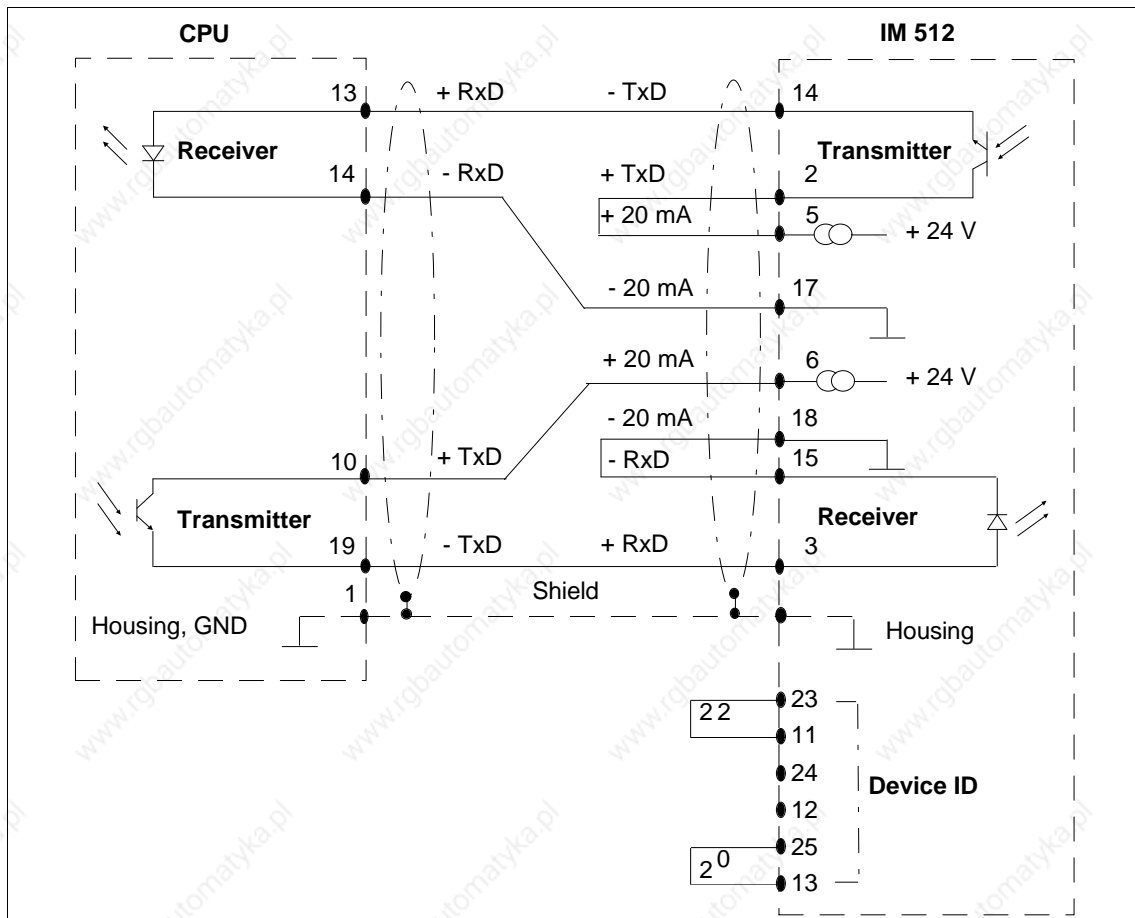

Figure 5-18 TTY Submodule: Connecting Cable for CPU, CP 524, CP 525, CP 544

**Connecting cable: CPU - IM 512**

To generate loop current, the IM 512 must be supplied with 24 V at the subminiature D-type connector in the front plate.



**5**

Figure 5-19 TTY Submodule: Connecting Cable CPU - IM 512

**Connecting cable CPU - DR 210/211, DR 230/231**

You can use this connecting cable with both the TTY and the V.24 submodule. Ensure that you have the same type of interface in the CPU and in the printer.

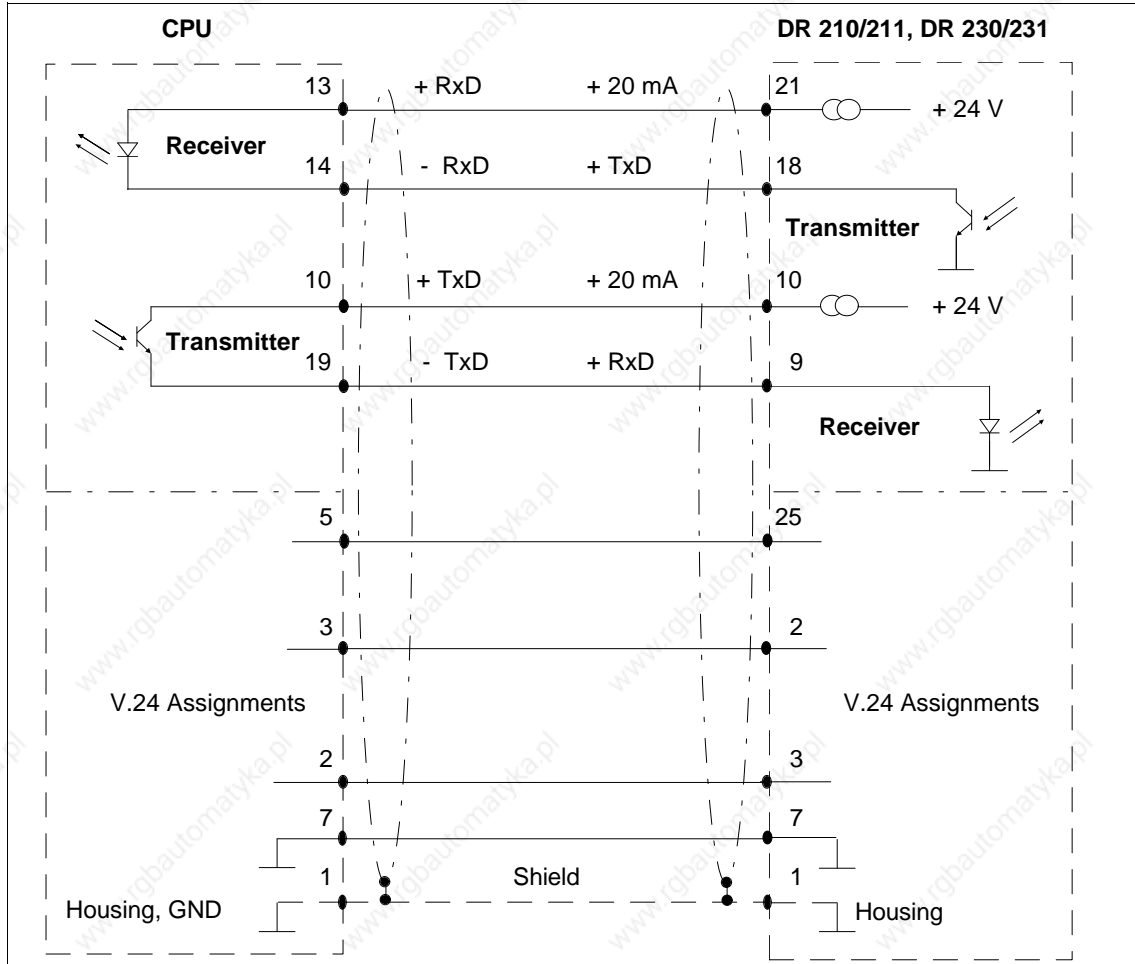

Figure 5-20 TTY Submodule: Connecting Cable CPU - DR 210/211, DR 230/231

### 5.8.5 RS422 A/485 Submodule

The RS422 A/485 submodule is for use exclusively in the RS422 A mode with the RK 512 computer link, data transmission with procedures 3964/3964R, data transmission with the "open driver".

#### Application

The RS422 A/485 submodule can be inserted in the following CPU:

Interface Submodule...	For Use With...
RS422 A/485 sub-module	CPU 928B

#### Circuitry

With the above types of communication, the RS422 A/485 submodule can only be used in full duplex operation implemented by hardware. The electrical characteristics are governed by EIA Standard RS422 A (CCITT Recommendation V.11).

Shown in the following figure is the circuitry for the interface (transmit and receive lines):

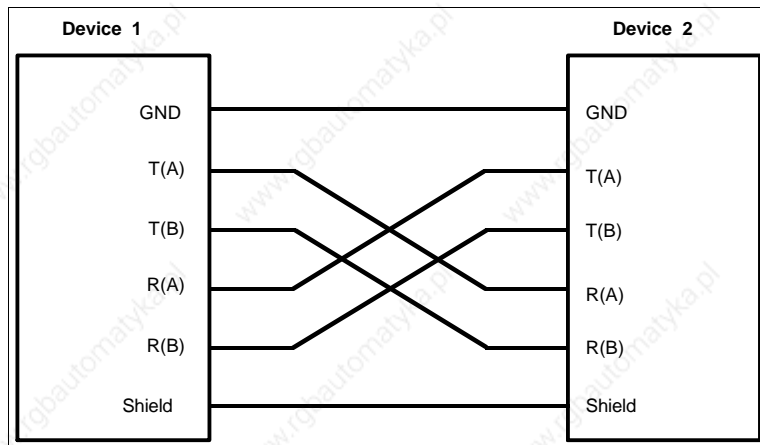

Figure 5-21 RS422 A/485 Submodule: Full Duplex Operation

Apart from the transmit and receive lines, the RS422 A/485 submodule has a number of control and signalling lines to CCITT Recommendation X.24 and ISO 8481. In association with the above types of communication, however, these control and message signals are not required and need therefore not be wired.

The RS422 A/485 is a differential voltage interface and therefore exhibits higher rejection of interference than a TTY or V.24 interface.

The following applies to the signals to EIA Standard RS422 A (V.11):

Logic 0 (ON) corresponds to  $V_A > V_B$

Logic 1 (OFF) corresponds to  $V_A < V_B$

In the RS422 A/485 submodule, the interface signals are isolated from the supply voltage of the PLC.



**Data transmission rate**

A maximum of 19200 bps is permissible for data transmission with the RS422 A/485 submodule when used in a CPU.

**Pin assignments of the RS422 A/485 submodule**

Shown in the following figure are the pin assignments of the 15-pin subminiature D-type connector in the front plate of the RS422 A/485 submodule:

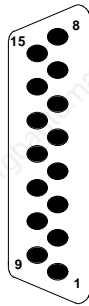

Pin	Des. to CCITT X.24	Input/Output	Remarks
1	Shield		
2	T(A)	Output	
3	C(A)	Output	
4	R(A)	Input/Output	In full duplex operation, only data can be received on this two-wire line.
5	I(A)	Input	
6	S(A)	Input	
7	B(A)	Output	
8	GND		
9	T(B)	Output	
10	C(B)	Output	
11	R(B)	Input/Output	In full duplex operation, only data can be received on this two-wire line.
12	I(B)	Input	
13	S(B)	Input	
14	B(B)	Output	
15	X(B)	Input	

### Jumper settings on the RS422 A/485 submodule

When the submodule is delivered, the jumpers are set as shown in the following figure. As a rule, therefore, you can use the RS 422 A/485 submodule immediately.

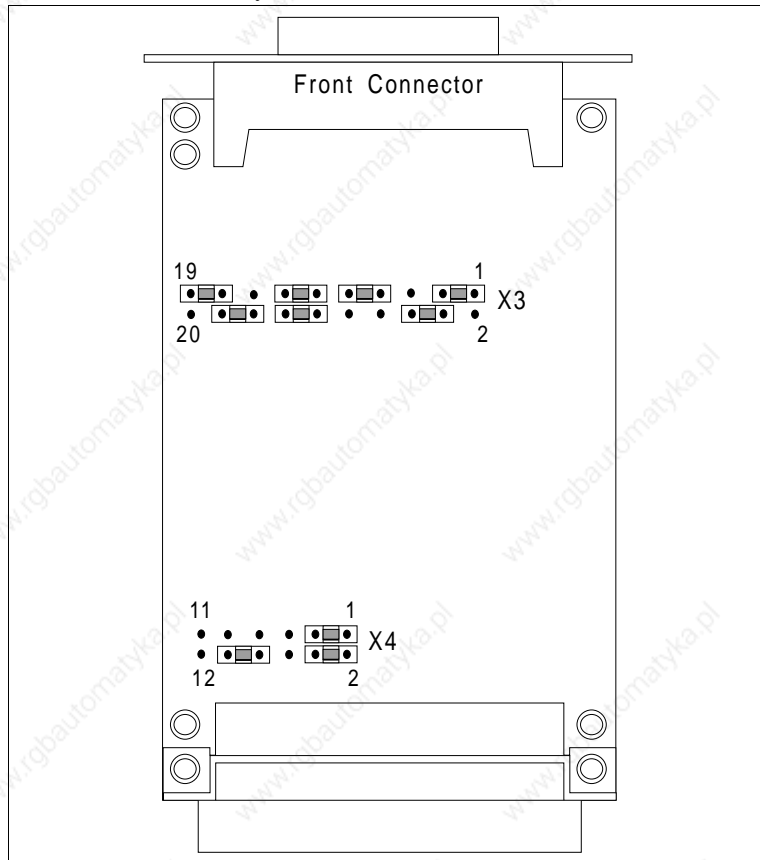

5

Figure 5-22 RS422 A/485 Submodule: Jumpers Settings when Delivered

With the jumpers on the switch row X3 you can remove the preset for recognizing a break state from the two-wire line R.

When delivered, the two-wire line R is preset with the jumpers 12-14 and 4-6 so that the break state can be recognized. Pin 4 (R(A)) of the front connector lies above a resistance on +5 V. Pin 11 (R(B)) of the front connector lies above a resistance on ground.

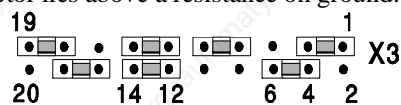

If you replug the jumpers on 10-12 and 6-8, the two-wire line R is preset as follows: pin 4 (R(A)) of the front connector lies above a resistance on ground. Pin 11 (R(B)) of the front connector lies above a resistance on +5 V. The break state cannot be recognized.

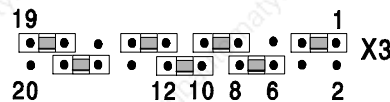

If you unplug the jumpers 12-14 and 4-6, the two-wire line R is not preset and the break state cannot be recognized clearly.

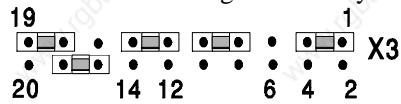

With the following jumper setting you can switch over the data direction on the two-wire line R:

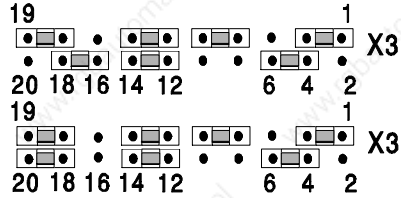

**Jumper 16-18:** setting for full duplex operation. Data can only be received on the two-wire line R (default).

**Jumper 18-12:** setting for half duplex operation. Data can be transmitted or received on the two-wire line R (special driver required).

With the following jumper setting you can switch the two-wire line B as an input or an output.

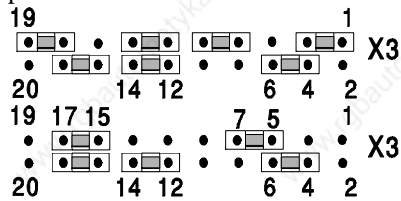

**Jumper 17-19:** two-wire line B is switched as an output. The line X(B) can be used as an input. X(A) is connected to ground (default).

**Jumper 15-17:** two-wire line B is switched as an input. The line X(B) cannot be used.

With the following jumper setting you can either place the signal /PS3 or the internal transmitting frequency (TxCint) on the two-wire line B. The two-wire line B must be switched as an output.

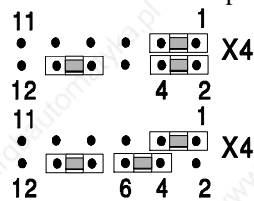

**Jumper 2-4:** the signal /PS3 can be transmitted via the two-wire line B (default).

**Jumper 4-6:** the internal transmitting frequency TxCint can be transmitted via the two-wire line B.

With the following jumper setting you can use the frequency transmitted via the two-wire line S as the receive frequency.

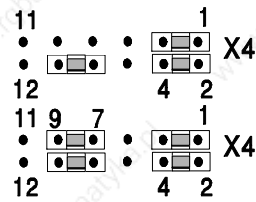

**Jumper 7-9 removed:** frequency on input S is not used as the receive frequency (default).

**Jumper 7-9 plugged:** frequency on input S is used as the receive frequency.

With the following jumper setting you can switch the transmit and receive frequencies.

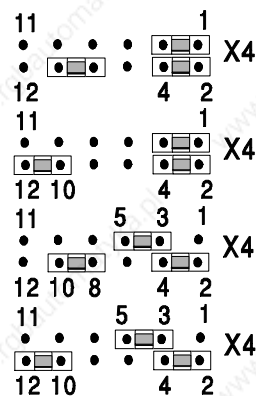

5

**Jumpers 8-10, 1-3:** the internal transmit frequency (TxCint) is used as the transmit and receive frequency (default).

**Jumpers 10-12, 1-3:** the internal transmit frequency (TxCint) is used as the transmit frequency and the internal receive frequency (RxCint) is used as the receive frequency.

**Jumpers 8-10, 3-5:** the frequency transmitted via the two-wire line S is used as the transmit and receive frequency.

**Jumpers 10-12, 3-5:** the frequency transmitted via the two-wire line S is used as the transmit frequency, the internal receive frequency (RxCint) is used as the receive frequency.

With the following jumper setting you can set the submodule for synchronous transmission with frequency control according to the DIN draft ISO 8481. The two-wire line B (identifier X to ISO 8481) must be switched as an output.

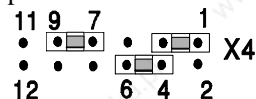

**Jumpers 1-3, 4-6, 7-9:** the internal transmit frequency (TxCint) is used as the transmit frequency. The internal transmit frequency is simultaneously transmitted on the two-wire line B.

**Standard connecting cables to the RS422 A/485 submodule**

Standard cables for connecting the RS422 A/485 submodule in the CPU to the partner station are available from Siemens in various lengths, up to 1200 m.

The order numbers and lengths can be found in the ordering information.

**Connecting cable for CPU, CP 524, CP 544**

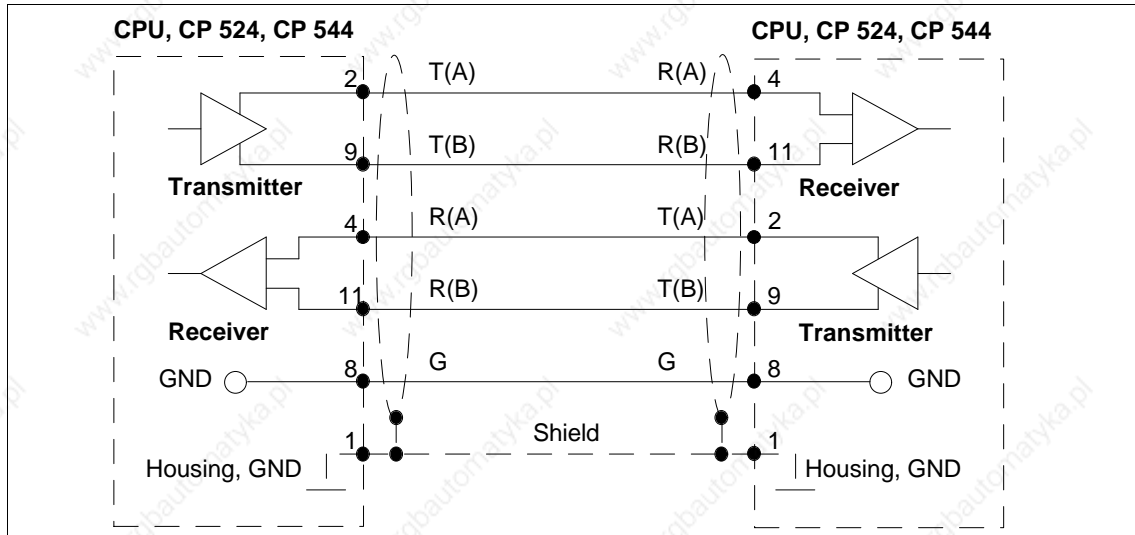

Figure 5-23 RS422 A/485 Submodule: Connecting Cable for CPU, CP 524, CP 544

### 5.8.6 SINEC L1 Submodule

The SINEC L1 submodule is for use with data transmission via the SINEC L1 bus.

#### Application

The SINEC L1 submodule can be inserted in the following CPU:

Interface Submodule...	For Use With...
SINEC L1 submodule	CPU 928B, from Version 6ES5 928-3UB12

#### Circuitry

The SINEC L1 submodule is equipped with a transmitter and a receiver for 20 mA current loop signals. Shown in the following figure is the circuitry for the current loop signals:

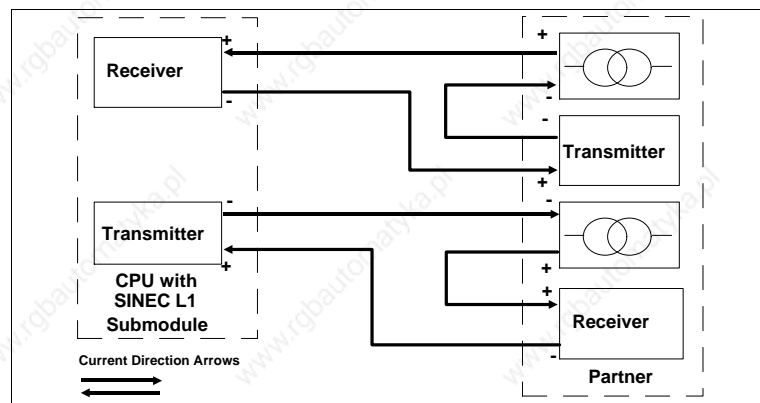

5

Figure 5-24 SINEC L1 Submodule: Loop Current Direction

#### Data transmission rate

Data transmission via the SINEC L1 interface always takes place at 9600 bps.

**Pin assignments of the SINEC L1 submodule**

Shown in the following figure are the pin assignments of the 15-pin subminiature D-type connector in the front plate of the SINEC L1 submodule:

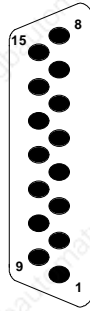

Pin	Designation	Current Direction	Remarks
1	Housing/GND/GND <sub>ext</sub>		
2	- RxD	→	
3	VPG + 5 V <sub>-</sub>		
4	+24 V from bus		
5	24 V GND		
6	+ TxD	←	
7	- TxD	→	
8	Housing/GND/GND <sub>ext</sub>		
9	+ RxD	←	
10	24 V ground	←	Current return
11	20 mA	→	Current source, transmitter
12	24 V ground		
13	20 mA	→	Current source, receiver
14	VPG + 5 V <sub>-</sub>		
15	24 V ground		

← : from partner to CPU  
 → : from CPU to partner

### **Jumper settings on the SINEC L1 submodule**

When the SINEC L1 submodule is delivered, the jumpers are set as shown in the following figure. As a rule, therefore, you can use the SINEC L1 submodule immediately.

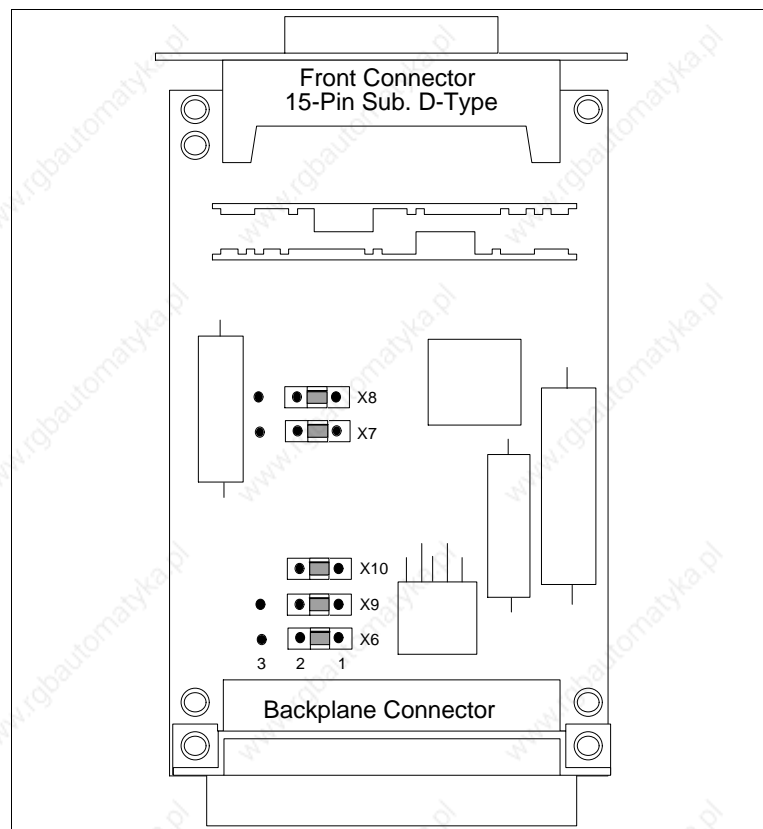

Figure 5-25 SINEC L1 Submodule: Jumper Settings when Delivered

### **BT 777 bus terminal**

The connection to the SINEC L1 bus system is provided by the BT 777 bus terminal. A detailed description of the bus terminal can be found in the manual entitled "SINEC L1 Bus System, 6ES5 998-7LA11).

The order number can be found in the ordering information.



**Connecting cable for point-to-point communication**

If the CPU 928B communicates as master in a point-to-point link with a slave, a connecting cable can be used instead of the bus terminal.

Shown in the following figure is connecting cable for point-to-point communication from the SINEC L1 submodule in the CPU to a partner.

**Connecting cable: CPU - partner (point-to-point communication)**

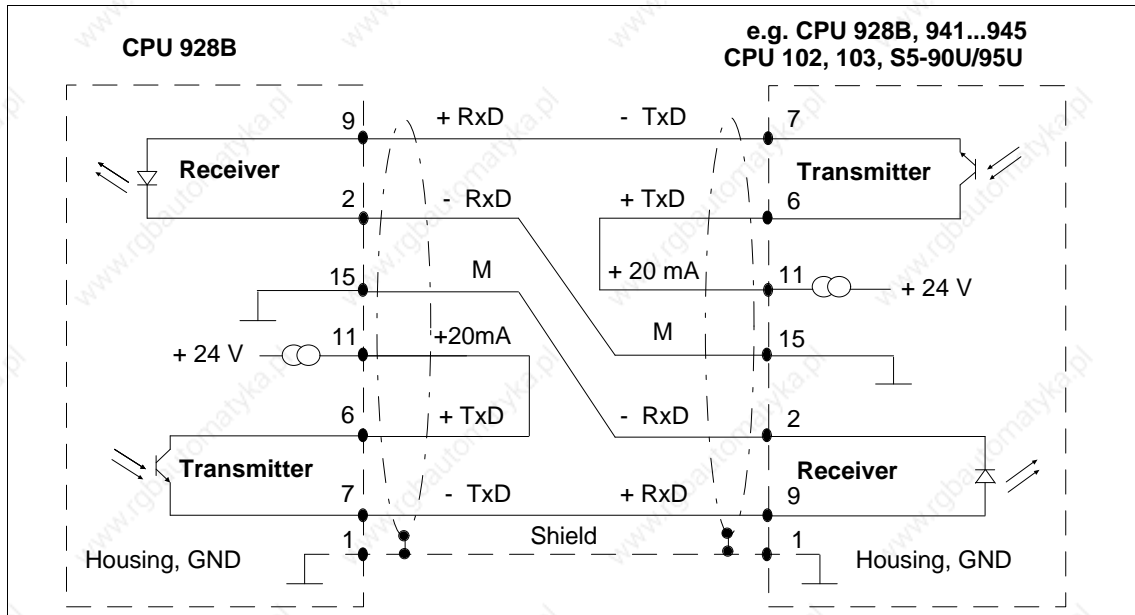

Figure 5-26 SINEC L1 Submodule: Connecting Cable for Point-to-Point Communication via the SINEC L1 Submodule

### 5.8.7 Technical Specifications of the Interface Submodules

#### Important for the USA and Canada

The following approvals have been obtained:



UL Listing Mark  
Underwriters Laboratories (UL) to  
Standard UL 508, Report E 85972



CSA Certification Mark  
Canadian Standard Association (CSA) to  
Standard C 22.2 No. 142, Report LR 63533

5

<b>Type of protection</b>	IP 00
<b>Ambient temperature</b> in operation for transportation and storage	0 to +55 °C - 40 to +70 °C
<b>Relative humidity</b>	95 % max. at 25 °C no condensation
<b>Supply voltage</b>	5V ± 5% 24V + 25%/- 17%
<b>Transmission rate</b> PG submodule V.24 submodule TTY submodule RS422 A/485 submodule SINEC L1 submodule	9600 bit/s fixed 19200 bit/s max. 9600 bit/s max. 19200 bit/s max. (when submodule is used in a CPU) 9600 bit/s fixed
<b>Front connector, female</b> PG, RS422 A/485, SINEC L1 submodule V.24, TTY submodule	15-pin Cannon 25-pin Cannon
<b>Transmission cable</b>	Shielded four-wire line (five-wire line for RS422 A) with braided shield and metal housing on connector, grounding required at both ends.
<b>Line length</b> PG submodule V.24 submodule TTY submodule RS422 A/485 submodule SINEC L1 submodule	1000 m max. 16 m max. 1000 m max. 1200 m max. 1000 m max.

<b>Current consumption at 5 V/24 V</b>	5 V	24 V
PG submodule	40 mA max.	380 µA
V.24 submodule	0.2 A max.	-
TTY submodule	0.1 A max.	60 mA
RS422 A/485 submodule	0.5 A max.	-
SINEC L1 submodule	170 mA max.	100 mA
<b>Design</b>		
Dimensions (WxHxD)	16.3 mm x 60 mm x 102.7 mm	
<b>Weight</b>		
per interface submodule	Approx. 0.1 kg	

# 6

## Multiprocessor Operation/ Coordinators

### Contents of Chapter 6

6	Multiprocessor Operation/Coordinators.....	6 - 3
6.1	Introduction.....	6 - 4
6.2	Starting the Multiprocessor Operation.....	6 - 5
	Procedure, overview .....	6 - 5
	Step 1 .....	6 - 8
	Step 2 .....	6 - 8
	Step 3 .....	6 - 10
	Step 4 .....	6 - 11
	Step 5 .....	6 - 11
	Step 6 .....	6 - 12
	Step 7 .....	6 - 13
	Step 8 .....	6 - 14
	Notes relating to multiprocessor start.....	6 - 14
6.3	Coordinator Modes .....	6 - 15
	The Stop state .....	6 - 15
	Startup .....	6 - 15
	Normal operation.....	6 - 15
	Test mode.....	6 - 16
6.4	923A Coordinator Module .....	6 - 17
6.4.1	Technical Description .....	6 - 17
	Application .....	6 - 17
	Design .....	6 - 17
	Principle of operation .....	6 - 18

## Contents

---

6.4.2	Settings on the Coordinator .....	6 - 19
	User control .....	6 - 19
6.5	923C Coordinator Module .....	6 - 20
6.5.1	Technical Description .....	6 - 20
	Application .....	6 - 20
	Design .....	6 - 21
	Principle of operation .....	6 - 21
	PG multiplexer .....	6 - 24
6.5.2	Settings on the Coordinator .....	6 - 25
	Indicators and controls .....	6 - 25
	Mode switch .....	6 - 25
	Setting the DIL switches .....	6 - 26
	Jumpers to switch off the coordination signals .....	6 - 29
	Fault register .....	6 - 29
6.6	Technical Specifications of the Coordinators .....	6 - 30

# Multiprocessor Operation/ Coordinators

# 6

This chapter explains how to install multiprocessor operation in the S5-135U/155U programmable controller and start operations.

You will require the 923A or 923C coordinator module. The technical functions of these modules are described.

6

## 6.1 Introduction

The S5-135U/155U is a member of the SIMATIC S5 family of programmable (logic) controllers. The PLC can be used both in single and in multiprocessor operation with up to four CPUs.

### Slots occupied

You can arbitrarily combine the CPUs in the central controller at the CPU slots.

CPU	Slot Requirement
CPU 948/CPU 928B/CPU 928	2 slots
CPU 922	1 slot

In multiprocessor operation, each CPU processes its individual user program independently of the other CPUs.

The common S5 bus serves for data interchange with I/O modules, CPs, IPs and other CPUs. In multiprocessor operation, access of the CPUs to the S5 bus is controlled by a coordinator. The functioning of this module is described in Sections 6.5 and 6.6.

For an explanation of data interchange between CPUs in multiprocessor operation and the arrangement of your STEP 5 program, please consult the Programming Guide for your CPU.

### Coordinator

A coordinator is required in multiprocessor operation. The following are available for the S5-135U/155U PLC:

- **923A** coordinator (COR A)

and

- **923C** coordinator (COR C).

The coordinator allocates to the CPUs the time divisions in which they can access the S5 bus (bus enable time), and contains the global memory for data interchange between the CPUs via communication flags. Additionally, the COR C contains another memory with four pages for the "multiprocessor communication" function as well as a serial PG interface with PG multiplexer function (PG MUX).

## 6.2 Starting the Multiprocessor Operation

This section guides you through the installation and startup of multiprocessor operation; the following is assumed:

- You are familiar with the use and programming of individual modules in single-processor operation. If this is not the case, please consult the relevant chapters in this manual and in the appropriate Programming Guides.

### Note

As soon as a coordinator is inserted in the S5-135U/155U central controller, all CPUs are automatically in multiprocessor operation irrespective of the number of inserted CPUs.

Even if the coordinator is only operated with one CPU, the conditions for multiprocessor operation apply to **this** CPU (DB 1 required, DX 0 possibly required, etc.).

### Procedure, overview

You can use up to four CPUs in the S5-135U/155U programmable controller. The permissible slots are indicated in Chapter 4.

Startup can be subdivided into the following steps:

Step	Action
1	Set the number of CPUs (inserted from the left) on the coordinator.
2	If you use communication flags on CPs: Mask out the communication flag areas on the coordinator.
3	Insert the CPUs and the coordinator in the slots provided in the central controller. <b>The CC must be disconnected from system voltage.</b>
4	Switch on the system voltage and Power switch on the power supply unit.
5	Execute an OVERALL RESET on all CPUs.
6	Load your STEP 5 user programs in all CPUs (including DB 1, additionally DX 0 for the CPU 948).
7	Execute a RESET on all CPUs.
8	Set the mode switch of the coordinator from the STOP to RUN or TEST setting.



Setting the jumpers

Shown in Figures 6-1 and 6-2 are the locations of jumpers and switches on the modules, at which the settings required for startup must be made.

**Note**

The settings of jumpers which are **not** described in the following text **must not be changed**.

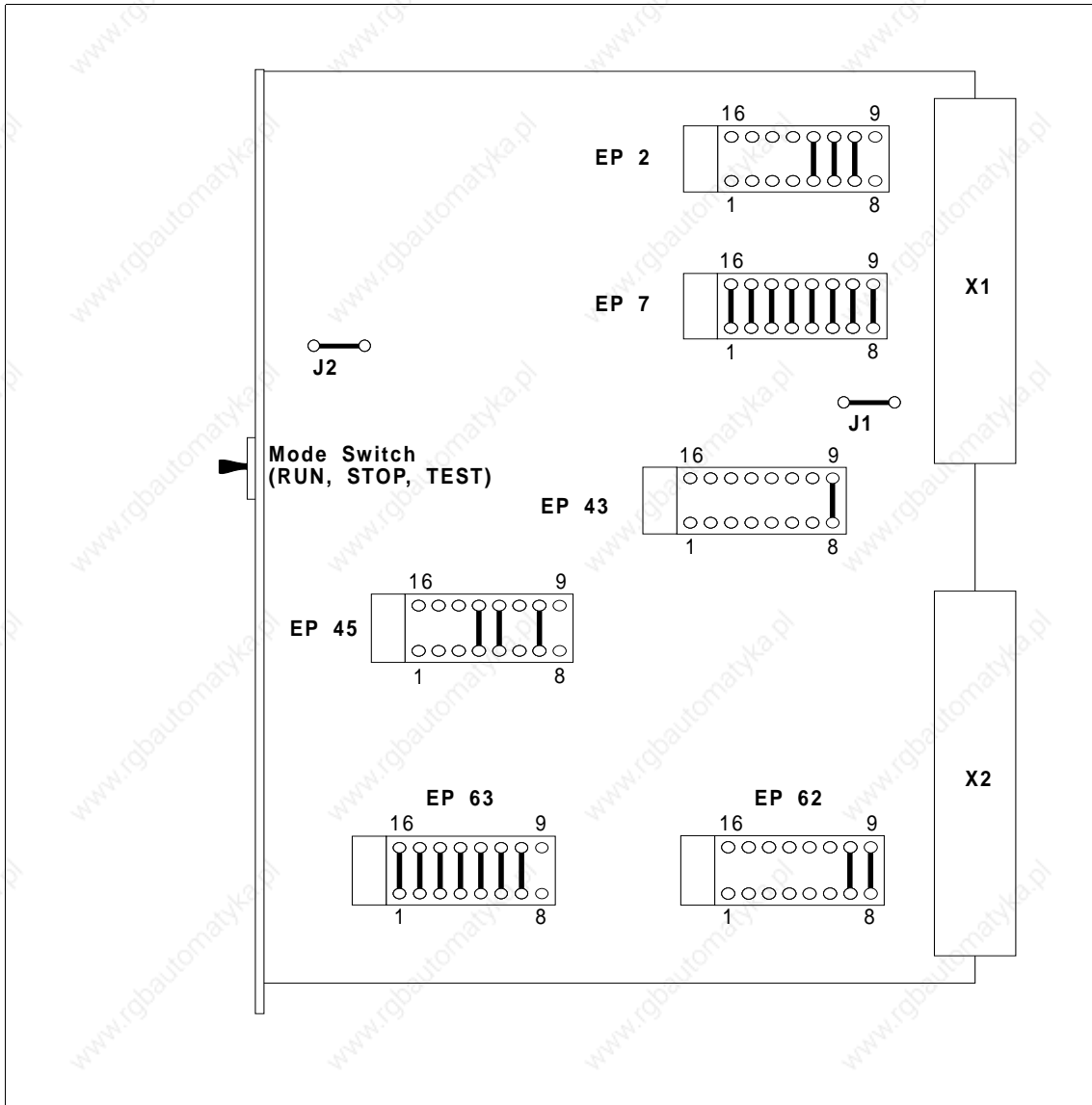
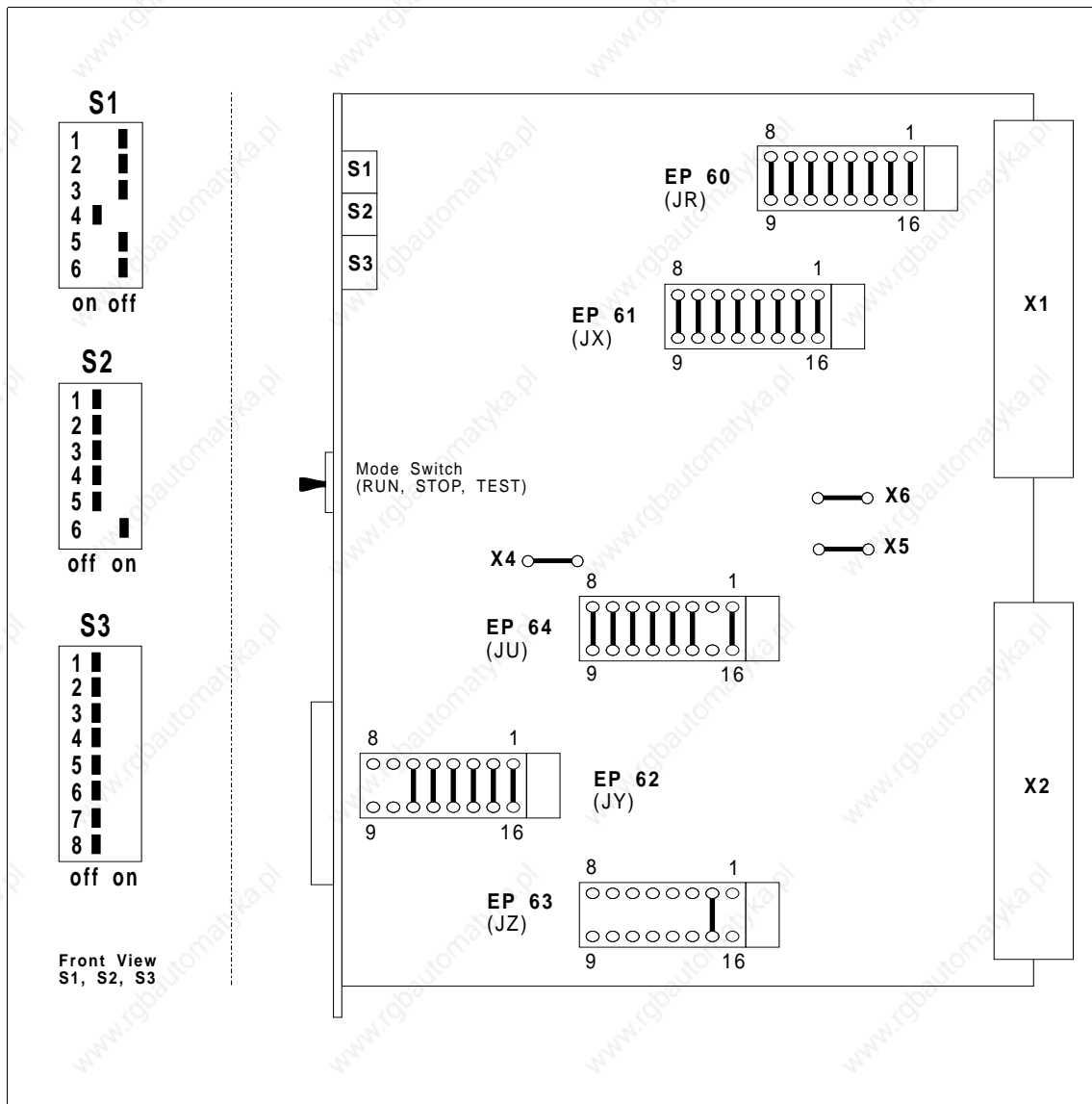

Figure 6-1 Locations of Jumpers on the 923A Coordinator (when Delivered)



6

Figure 6-2 Locations of Jumper Sockets and Switches on the 923C Coordinator and Front View of Switches S1 to S3 (when Delivered)

The individual actions are explained in more detail in the following.

**Step 1**

**Setting the number of occupied CPU slots on the coordinator:**

<b>923A Coordinator</b>			
Number of CPUs used		Jumper(s) at EP 62	
2		7 - 10; 8 - 9 <sup>1)</sup>	
3		7 -10	
4		8 - 9	
<b>923C Coordinator</b>			
Coded by inserting only one DIL switch S1.4, S1.5 or S1.6 in the front plate recess: (see Figure 6-2)			
DIL S.	on	off	Effect
S1.1		x	—
S1.2		x	—
S1.3		x	Enable test mode
S1.4	x		No. of occupied CPU slots = 2 <sup>1)</sup>
S1.5		x	No. of occupied CPU slots = 3
S1.6		x	No. of occupied CPU slots = 4

<sup>1)</sup> Setting when delivered

**Step 2**

**Setting the communication flag areas:**

<b>IF...</b>	<b>THEN...</b>
you use communication flag areas on CPs (please consult the relevant manuals),	you must mask out these areas (blocks) on the coordinator without fail, to avoid duplicated addressing of the communication memory.  The 256 communication flag bytes can be masked out in groups of 32. You do this by removing jumpers at coding socket EP 7 on Coordinator A (see Figure 6-1 for location) or EP 60 on Coordinator C (see Figure 6-2).

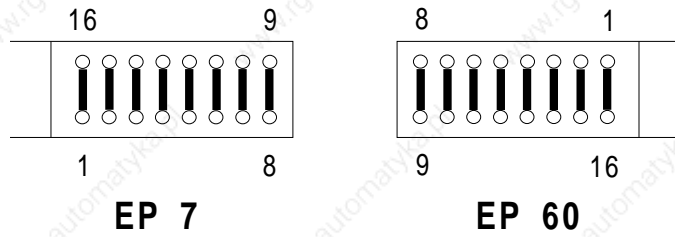

When the unit is delivered, all communication flag areas are activated (see above):

On Coordinator A by jumpers at EP 7  
 On Coordinator C by jumpers at EP 60

Jumper	Comm. Flag Byte	Address
8 - 9	0 to 31	F200H to F21FH
7 - 10	32 to 63	F220H to F23FH
6 - 11	64 to 95	F240H to F25FH
5 - 12	96 to 127	F260H to F27FH
4 - 13	128 to 159	F280H to F29FH
3 - 14	160 to 191	F2A0H to F2BFH
2 - 15	192 to 223	F2C0H to F2DFH
1 - 16	224 to 255	F2E0H to F2FFH

6

Jumper inserted: area activated (coordinator acknowledges in this area)

Jumper not inserted: area masked out (coordinator does not acknowledge in this area)

**Examples**

You wish to mask out the four communication flag areas with the highest addresses on COR A:

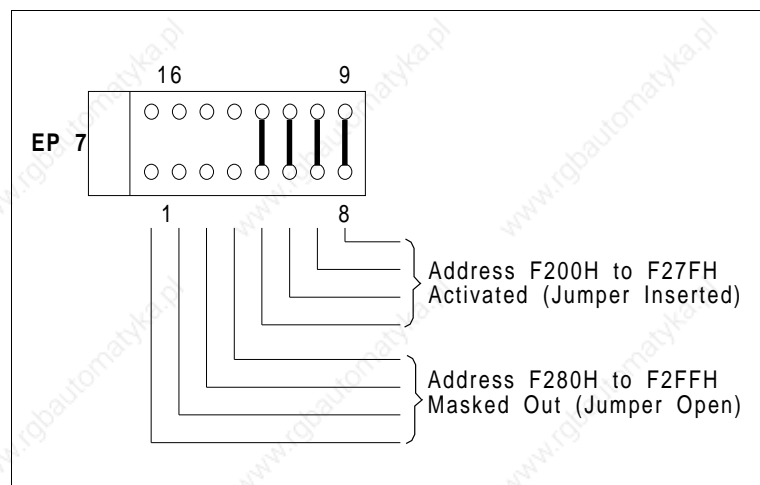

Figure 6-3 Example of Addressing the Communication Memory on COR A

You wish to mask out the four communication flag areas with the highest addresses on COR C:

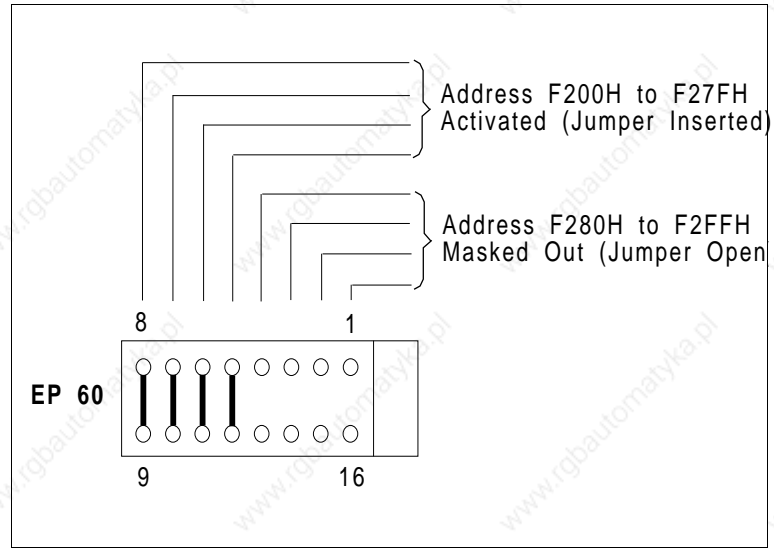

Figure 6-4 Example of Addressing the Communication Memory on COR C

**Step 3**

**Inserting CPUs and coordinator in the central controller:**

- Precondition: The central controller is not yet switched off.

Substep	Action	Reaction
3a	Insert the CPUs and coordinator in the relevant slots.	none
3b	Insert all EPROM or RAM submodules in the CPUs according to the configuration.  The EPROM submodules must have been previously programmed with a PG.	none
3c	Set all mode switches on the CPUs and on the coordinator to STOP.	none

**Step 4**

Action	Reaction
Switch the supply voltage on.	<ol style="list-style-type: none"> <li data-bbox="994 297 1358 421">1. The red STOP LEDs flash rapidly on all CPUs to indicate: Overall reset requested.</li> <li data-bbox="994 454 1358 732">2. If the test mode is <b>not set</b> at the coordinator (see Section 6.3) and the mode switch is <b>not at the TEST setting</b>: <b>The red BASP (output inhibit) LED is permanently lit to indicate: Digital outputs are inhibited.</b></li> </ol>

**Possible faults****Symptom:**

On some CPUs the STOP LED is not lit; the other CPUs are requesting OVERALL RESET. All CPUs are emitting the BASP (output inhibit) signal.

**Remedy:**

Check the setting for the number of occupied CPU slots on the coordinator. Are the CPUs inserted at suitable slots?

**6****Step 5****Executing an OVERALL RESET on all CPUs:**

Ensure that the mode switch on the coordinator is set to STOP. (Precondition: Steps 3 and 4 have been fully executed.)

Action	Reaction
Execute the OVERALL RESET for each individual CPU:  Hold the MC <sup>1)</sup> mode switch in the OVERALL RESET setting; simultaneously set the mode switch from STOP to RUN and back to STOP.	The red STOP LEDs on the CPUs at which the OVERALL RESET was executed, light up continuously. Each CPU additionally emits the output inhibit signal (BASP LED continuously lit).

<sup>1)</sup> MC: Momentary-contact

**Step 6**

**Loading STEP 5 user programs in all CPUs:**

- Recommended precondition: The programs of the individual CPUs have already been tested in single-processor operation.

For details of loading STEP 5 blocks and using the different types of memory, please consult the relevant Programming Guides of the CPUs and your PG Manual.

<b>Prerequisites</b>	
What?	Where?
<b>Data block DB 1 must</b> be present for I/O allocation.	in all CPUs <sup>1)</sup>
<b>Data block DX 0 must additionally be present at CPU 948.</b> The mode for "Process interrupts via IB 0 = off" must be set in DX 0.	only in CPU 948
To start multiprocessor operation immediately with all CPU programs, you must now load your programs into the individual CPUs.  After completing these steps, however, you can load individual programs into certain CPUs.	into the desired CPU <sup>1)</sup>

<sup>1)</sup> You must only load the blocks for CPUs with RAM operations; for EPROM operation, the inserted EPROMs must contain your user program with DB 1 (DX 0). Data blocks which you have provided for dynamic data storage must be copied after a RESET by program into the RAM.

<b>Reaction</b>
There is <b>no</b> change in the reactions of Step 4 (each CPU still emits the output inhibit signal: the BASP LED is continuously lit).

**Step 7****Executing a RESET at all CPUs:**

Action	Reaction
Execute a RESET at each individual CPU: Hold the MC <sup>1)</sup> mode switch at the RESET setting; simultaneously set the mode switch from STOP to RUN.	The red STOP LED on each CPU is continuously lit; each CPU emits the output inhibit signal. The CPUs are in the wait state.

<sup>1)</sup> MC: Momentary-contact

**Possible faults****Symptom 1:**

The STOP LED of one CPU flashes slowly. When the control bits of this CPU are read out with the programmer, "DB 1 error" is marked in addition to the usual information. There is no output of an ISTACK.

**Remedy:**

Check whether data block DB1 in the CPU was correctly loaded and programmed.

**Symptom 2:**

After execution of a RESET:

Undefined states or faults occur at the CPUs (e.g. after a RESTART at CPU 922, it goes to the RUN state although the other CPUs are still at STOP).

**Remedy:**

Verify the following points:

- Is the coordinator inserted?
- Are all modules correctly inserted (engaged)?
- Are all modules at the correct slots?



**Step 8**

**Setting the coordinator mode switch to RUN or TEST:**

IF...	THEN...	Reaction
You do not wish to work in the test mode <sup>1)</sup>	set the coordinator mode switch from STOP to RUN.	The green RUN LEDs of all CPUs are continuously lit. All CPUs simultaneously go into the cycle. The output inhibit signal is not emitted (BASP LED = off).
you wish to work in the test mode (it must be enabled on the coordinator) <sup>1)</sup>	set the coordinator mode switch from STOP to TEST.	set the coordinator mode switch from STOP to TEST.

<sup>1)</sup> Test mode and setting: see Section 6.3

**Possible faults**

**Symptom:**

All CPUs remain in the Stop state.

**Remedy:**

Check whether the mode switches of all CPUs are set to RUN.

A subsequent start of individual CPUs is not possible. Switch the coordinator back to STOP. Execute a RESET at all CPUs and then switch the coordinator to RUN again.

**Note**

During the starting phase (processing of the start OBs) the STOP and RUN LEDs remain off at all CPUs. The RUN LED only lights up continuously when the CPUs go over to cyclic program processing.

**Notes relating to multiprocessor start**

- When the coordinator is switched from STOP to TEST, only the CPUs whose switches are at the RUN setting will operate in the test mode.
- If the 923C coordinator is used and the PG interface on the front plate is not connected to the PG and switched online, the IF FAULT LED lights up on the 923C coordinator. The indicator can be ignored in this case.

## 6.3 Coordinator Modes

### **The Stop state**

If, when the supply voltage is switched on, the coordinator mode switch is at STOP or another stop request is pending, the CPUs remain in the Stop state.

### **Startup**

#### **AUTOMATIC RESET or AUTOMATIC RESTART**

If, when the supply voltage is switched on, the coordinator mode switch is at RUN, an AUTOMATIC RESET or AUTOMATIC RESTART (depending on DX 0 setting) will take place as long as the mode switches of the CPUs are also at RUN and the PLC was previously in cyclic operation.

#### **MANUAL START**

When you set the coordinator mode switch from STOP to RUN, the CPUs will execute a start if this was already prepared at all CPUs by appropriate switch actuation, i.e. the CPUs are in the wait state. As required by the user, the type of start can be the same for all CPUs or arbitrarily different.

After the start synchronization by the system programs, the CPUs simultaneously go to RUN (cyclic operation).

### **Normal operation and Stop in the event of faults**

The transition of individual CPUs is synchronized - as long as the preset "start synchronization" in the relevant CPUs has not been changed by DX 0 programming - i.e. only when each CPU has ended its start do all CPUs jointly go to cyclic program processing.

If the coordinator mode switch is at the RUN setting and one CPU goes to the Stop state, all the other CPUs also go to the Stop state. The red STOP LED(s) on the CPU(s) causing the Stop state flash slowly; the STOP LEDs of the other CPUs are continuously lit.

Apart from any indication with fault LEDs on the CPU which is the cause, all CPUs emit the BASP (output inhibit) signal.

**Test mode**



**Warning**

Since, in the test mode, no CPU can emit a BASP (output inhibit) in the event of a fault, the test mode must be switched to the inactive state without fail after completion of startup to avoid a critical or even hazardous system state.

Before you can go into the test mode with the TEST switch, you have to enable it on the module. This is achieved differently with the 923A and 923C coordinators.

*Enabling the test mode with the 923A*

Insert jumper 3 - 14 on coding socket EP 45 as shown in the following sketch.

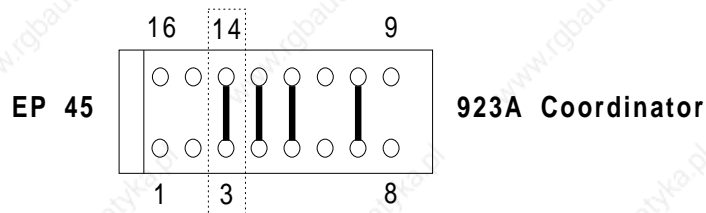

*Enabling the test mode with the 923C*

Set DIL switch S1.3 from Off to On (the following table shows the DIL switches as delivered; see also Figure 6-2).

*Reaction of the CPUs*

DIL S.	On	Off	Effect
S1.1		x	—
S1.2		x	—
S1.3	←	x	<b>Test mode</b>
S1.4	x		No. of occupied CPU slots = 2
S1.5		x	No. of occupied CPU slots = 3
S1.6		x	No. of occupied CPU slots = 4

When the coordinator mode switch is set from STOP to TEST, the CPUs can be started individually. There is therefore no synchronized transition to cyclic program processing. The output of signal BASP is suppressed on all CPUs, even if there is an error.

If an error occurs with a CPU switched to RUN, only this one goes to the Stop state in the test mode. The error is indicated by slow flashing of the CPU's STOP LED. The error at this CPU does not affect other CPUs.

If the test mode is not activated, a changeover from STOP to TEST does not result in any reaction of the CPUs.

## 6.4 923A Coordinator Module

### 6.4.1

#### Technical Description

This section contains information on the application, design and principle of operation of the 923A coordinator.

#### Application

The 923A coordinator module is intended for operation in the S5-135U/155U PLC. It is required in multiprocessor operation and has the following functions:

- **Bus arbitration**

To coordinate multiprocessor operation, i.e. the simultaneous use of two to four CPUs (CPU 928B, CPU 928 or CPU 922).

- **Communication memory**

for the interchange of data between CPUs via communication flags.

**6**

#### Note

The 923A coordinator module cannot be used in multiprocessor operation **if a CPU 948 is fitted in the 135U/155U PLC.**

If you execute global memory access in multiprocessor operation (I/O area with addresses 0000H-EFFFH) with the CPU 928B and/or the CPU 928, you must use the COR 923C as the coordinator.

#### Design

The COR 923A is designed as a plug-in PCB of double Eurocard format.

Two 48-way Series 2 blade connectors serve to connect the PCB to the S5 bus in the subrack.

The front plate width is 1 1/3 standard plug-in stations.

A three-position mode switch is fitted in the front plate for operator functions.

**Principle of operation****Bus arbitration**

The COR 923A cyclically allocates a bus enable signal to each of the two to four CPUs in the S5-135U/155U PLC. Only during this time can the relevant CPU utilize the common S5 bus.

The assignment of bus enable signals takes place in time-division multiplex operation. On the COR 923A, you set the number of CPUs with jumpers. The enable time for access to the S5 bus is preset at  $2\ \mu\text{s}$  for all CPUs. If the bus enable signal has been emitted by the coordinator for a CPU, this CPU can extend the enable time with the bus lock signal. However, the user has no influence on this.

The bus enable assignment sequence begins with CPU 1 after the Reset signal is removed by the power supply, and enables the CPUs in the following order according to the preset number of CPUs:

CPU 1, CPU 2, CPU 3, CPU 4, CPU 1, CPU 2 etc. (see Figure 6-5)

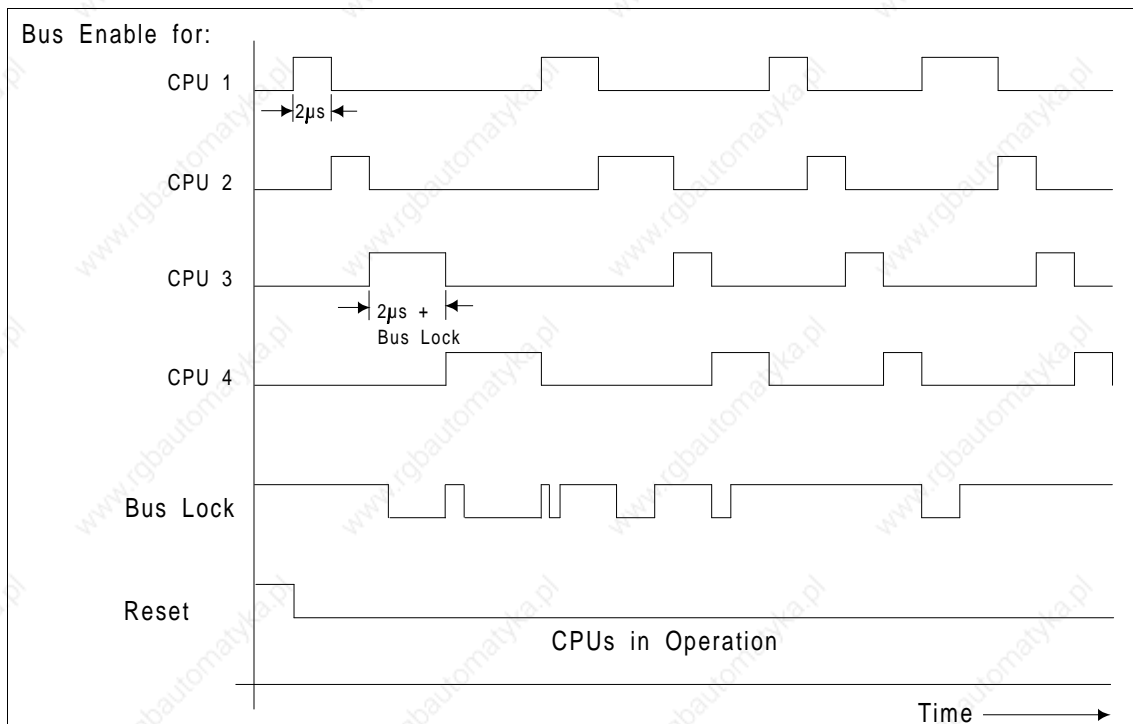

Figure 6-5 Timing Sequences of the Bus Control Signals

### Communication memory

The communication memory comprises a central battery-backed RAM in the PLC. It has two areas: the communication flags and the semaphores.

The communication flags on the COR 923A allow the cyclic interchange of data between the CPUs. The semaphores are mainly used to coordinate the exchange of data in the I/O area.

Please consult the Programming Guides of the CPUs to program these functions.

#### 6.4.2 Settings on the Coordinator

##### *User control*

A three-stage mode switch on the front plate serves for user control; it has the settings RUN, STOP and TEST.

The functions of the mode switch and its use are explained in Sections 6-2 and 6-3.

6

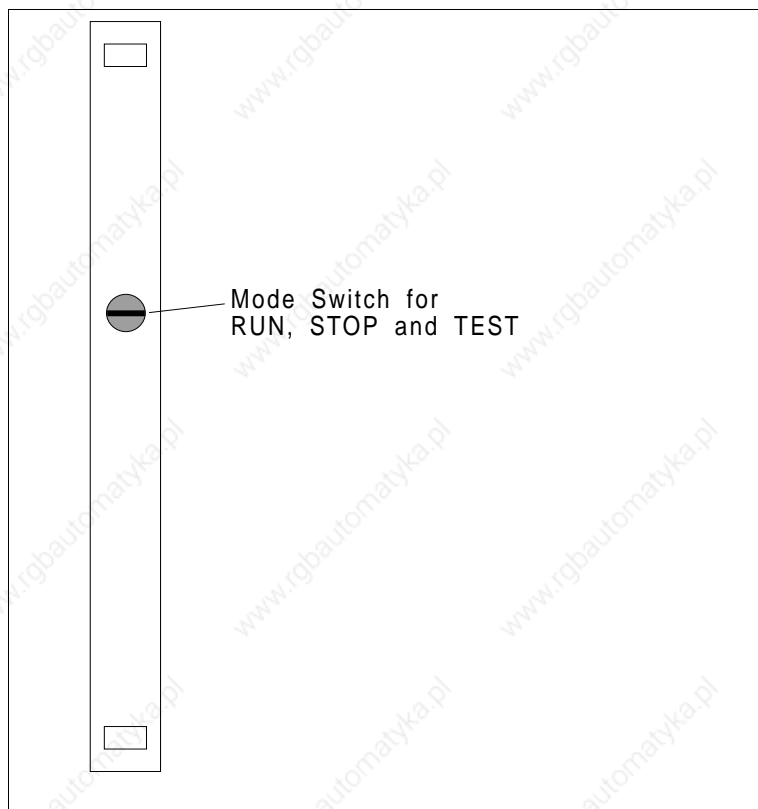

Figure 6-6 Front Plate of the COR 923A

## 6.5 923C Coordinator Module

### 6.5.1

#### Technical Description

This section contains information on the application, design and principle of operation of the 923C coordinator.

#### Application

The 923C coordinator module can be used in the S5-135U/155U programmable controller and in the EU S5-185U expansion unit. There are three main task areas which are, to some extent, independent:

- **Bus arbitration** (only in the central controller)

To coordinate multiprocessor operation, i.e. the simultaneous use of two to four CPUs (CPU 948, CPU 928B, CPU 928, CPU 922).

- **Communication memory** (only in the central controller)

For the interchange of data between CPUs via communication flags and data blocks.

- **Central programmer connection (PG MUX)**

For the programming and startup of up to 8 modules via one PG connection.

To program a programmable controller via the SINEC H1 or SINEC L1/L2 bus, connect the SINEC CP to the PG connection of the COR C using the 725 cable ("swing" cable).

**Design**

The COR 923C is designed as a plug-in PCB in double Eurocard format.

Two 48-way Series 2 blade connectors serve to connect the module to the S5 bus in the subrack.

The front plate width is 1 1/3 standard plug-in stations.

A mode switch with three settings is fitted in the front plate for other operator functions.

Faults are indicated by five small red LEDs.

There is a recess with cover in the upper third of the front plate. By removing the cover, you can operate the DIL switches to set parameters for the module.

You can connect the COR 923C via a 15-pin front connector to a programmer, OP, operator control panel or the CP 530 and CP 143.

**6****Principle of operation****Bus arbitration**

The COR 923C cyclically allocates a bus enable signal to each of the two to four CPUs in the S5-135U/155U PLC. Only during this time can the relevant CPU utilize the common S5 bus.

The assignment of bus enable signals takes place in time-division multiplex operation. On the COR 923C, you set the number of CPUs with DIL switches. The enable time for access to the S5 bus is preset at 2  $\mu$ s for all CPUs. If the bus enable signal has been emitted by the coordinator for a CPU, this CPU can extend the enable time with the bus lock signal. However, the user has no influence on this.



The bus enable assignment sequence begins with CPU 1 after the Reset signal is removed by the power supply, and enables the CPUs in the following order according to the preset number of CPUs:

CPU 1, CPU 2, CPU 3, CPU 4, CPU 1, CPU 2 etc. (see Figure 6-7)

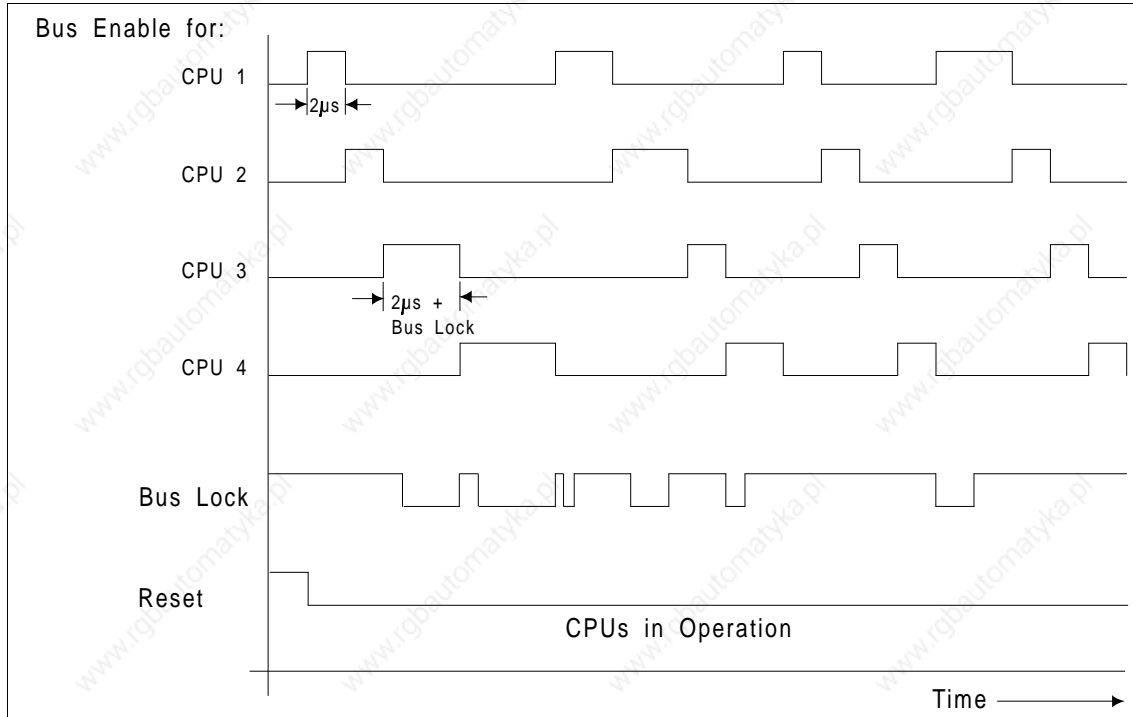

Figure 6-7 Timing Sequences of the Bus Control Signals

### Monitoring for continuous bus assignment

The bus lock signal can only be emitted by the CPU which has already received a bus enable signal from the COR 923C. The bus enable time is extended by the duration of the bus lock signal for the CPU (see Figure 6-7). The factory setting for monitoring of the bus lock signal is 2 ms. If the signal remains active for a longer duration, the COR 923C emits a signal which results in a Stop of all CPUs.

The CPU which emitted the bus lock signal for too long a duration, is marked by the CPU in a readable register under address FEFFH (fault register, see Figure 6-8). The assigned BUS FAULT LED in the front plate of the COR 923C lights up. The register is cleared and the LED goes off again when the signal which led to the Stop state becomes inactive.

## Communication memory

The communication memory comprises a central battery-backed RAM in the PLC. It has three areas: 1) the communication flags (256 bytes), 2) the semaphores (32), and 3) four memory pages.

The communication flags are located in memory area F200H to F2FFH. The communication flags enable the cyclic interchange of small volumes of data between the CPUs in the S5-135U/155U PLC. The four memory pages serve for the exchange of data blocks between CPUs.

Please consult the Programming Guides of the CPUs to program these two functions.

The semaphores are used to coordinate the CPUs for access to the same I/O address (see Programming Guides, operations SES and SEF).

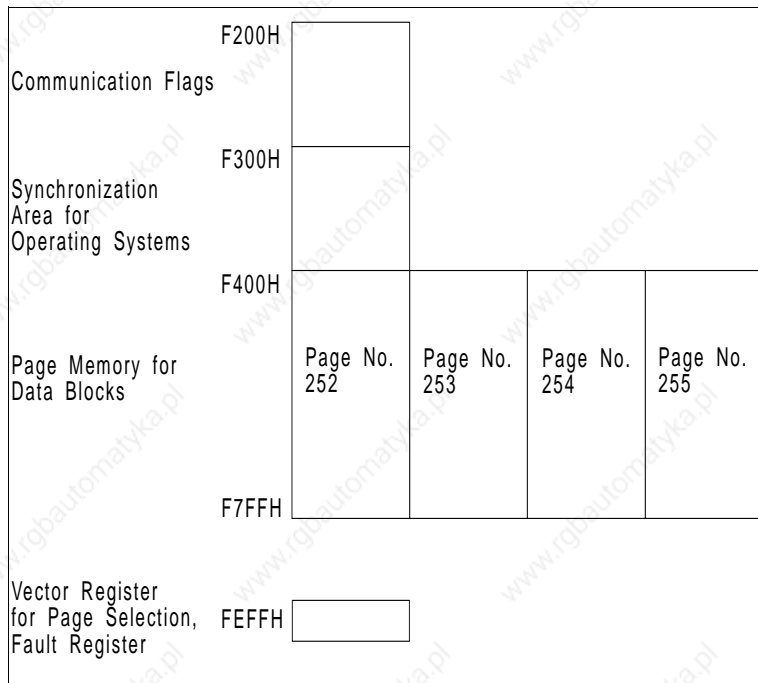

6

Figure 6-8 Areas of the Communication Memory on the S5 Bus

### Addressing method for the page memory (vector register)

The vector register serves to form subaddresses of several memories in a common address area. The register is an 8-bit register which is written to under address FEFFH. It cannot be read out.

The page memory contains four pages of 1 Kbyte. An identification number is assigned to each page. These are the numbers 252, 253, 254 and 255.

These numbers are permanently set on the COR 923C and cannot be changed. You must not use these numbers on other modules (CP, IP) in the same PLC otherwise double addressing will occur.

When the supply voltage is switched on, the vector register is cleared. The vector register then has the number 0H.

The transfer of data to and from this memory is implemented with special functions of the CPU. You can find these functions in the appropriate Programming Guides.

### **PG multiplexer**

The PG interface of the COR 923C can be switched over to eight different serial interfaces via the path selection of the PG software. The multiplex interfaces have TTL level and are wired to the other modules via the backplane connector and backplane.

#### *Selection method for the serial interfaces*

Station numbers are assigned to all the modules to be served by the multiplexer in the unit. These numbers must be within the range 1 to 31 (decimal). You set the lowest of these numbers, the base address, with DIL switch S2 in binary code. The maximum of eight numbers are allocated to the slots of the PLC (see following table).

All eight numbers or slots are assigned to switch S3: the lowest number to switch S3.1, and the highest number to switch S3.8. The setting of station numbers and the base address are described in more detail in Section 6.5.2.

Switch	Slot	Station No.
S3.1	11	Base address
S3.2	27	Base address + 1
S3.3	43	Base address + 2
S3.4	59	Base address + 3
S3.5	75	Base address + 4
S3.6	83	Base address + 5
S3.7	91	Base address + 6
S3.8	99	Base address + 7

If slots are not occupied or if you wish to operate modules via their own front connectors, you must delete the numbers assigned to the corresponding slots with switch S3.

#### **Note**

For a module operated via the multiplexer, the **front connector of the PG interface of the CPU** must not be plugged in. With CPUs 948 and 928B, this only applies to the integrated PG interface SI 1.

## 6.5.2 Settings on the Coordinator

### Indicators and controls

Shown in Figure 6-9 are all the indicators and controls on the front plate of the COR 923C.

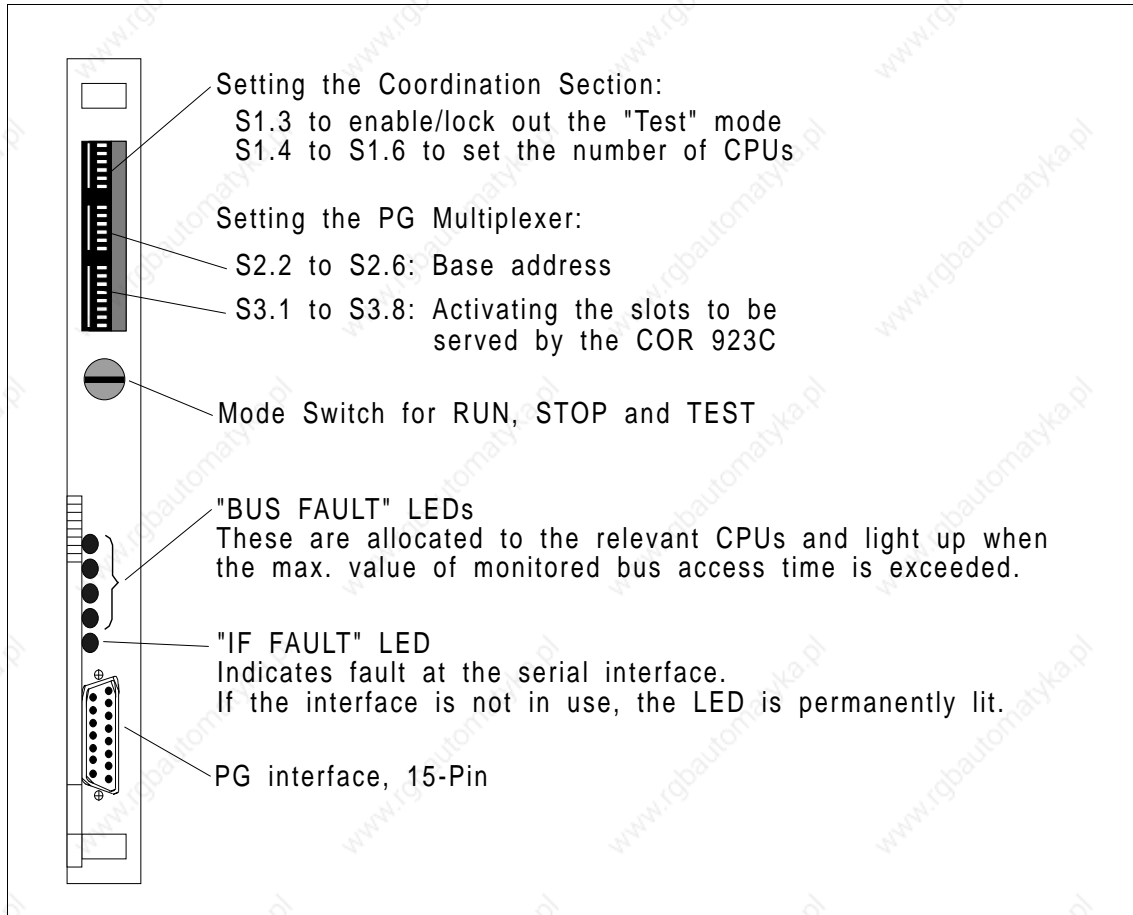

6

Figure 6-9 Front Plate of the COR 923C

### Mode switch

The mode switch on the front plate can be set to RUN, STOP and TEST.

Please refer to Sections 6-2 and 6-3 for its functions and use.

**Setting the DIL switches**

**Note**

On switch S1, the On position is on the left; on switches S2 and S3, however, it is on the right (see Figure 6-10).

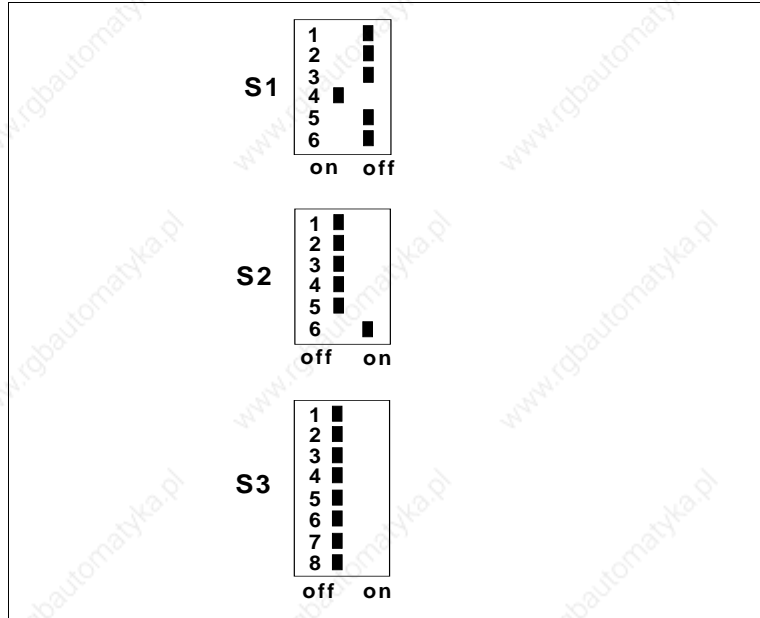

Figure 6-10 DIL Switches on the COR 923C (Settings when Delivered)

**Coordination section  
(number of CPUs)**

You set the number of CPUs present in the PLC with the 3 DIL switches S1.4 to S1.6. You may only set **one** switch.

The factory setting is "Number of CPUs = 2" (see below).

Factory setting:

Switch	Setting		Meaning
	on	off	
S1.1		x	—
S1.2		x	—
S1.3		x	Test mode (see also Sec. 6.3)
S1.4	x		Number of CPUs = 2
S1.5		x	Number of CPUs = 3
S1.6		x	Number of CPUs = 4

**PG multiplexer:  
base address**

You set a base address from 1 to 31 with DIL switch S2. You can reference the modules selected by the multiplexer under this address and the following seven addresses. The base address results from the sum of binary significances activated by the On setting of the switch.

Factory setting:

Switch	Setting		Meaning
	on	off	
	'0'	'1'	
S2.1	x		—
S2.2	x		Significance 16
S2.3	x		Significance 8
S2.4	x		Significance 4
S2.5	x		Significance 2
S2.6		x	Significance 1 (base address = 1)

6

**PG multiplexer:  
activating addresses**

You use switch S3 to activate the numbers and slots to be reached via the COR 923C.

Factory setting:

Switch	Setting		Meaning	Slot No. in the S5-135U/155U
	on	off		
S3.1	x		Base address + 0	11
S3.2	x		Base address + 1	27
S3.3	x		Base address + 2	43
S3.4	x		Base address + 3	59
S3.5	x		Base address + 4	75
S3.6	x		Base address + 5	83
S3.7	x		Base address + 6	91
S3.8	x		Base address + 7	99

An example for setting the PG multiplexer is given on the following page.



**Jumpers to switch off the coordination signals**

All the output signals required for coordination (arbitration) can be interrupted by removing a jumper plug. This is necessary to operate the COR 923C as a PG multiplexer in the EU S5-185U.

Coordination Section	
<b>in operation</b>	<b>out of operation</b>
All jumpers of EP 61 closed	All jumpers of EP 61 open

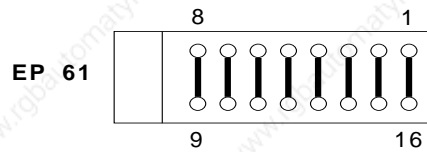

6

When the unit is delivered, all jumpers are closed.

**Fault register**

The fault register is an 8-bit register and is readable by the CPU under address FEFFH. The register is written to by the bus monitor in the event of a bus error. Each CPU is assigned one bit of the fault register which is set to 1 in the event of an error. The register is cleared each time the Stop signal becomes inactive.

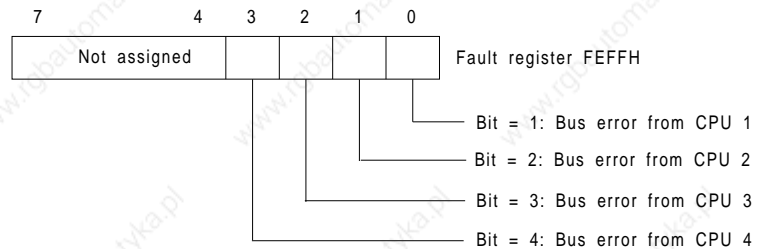

The fault register can be read by all CPUs, allowing central functions to be initiated.

**Note**

The fault register and the page register are at address FEFFH (FEEFFH with the CPU 948). The page register is addressed by writing to FEFFH, and the fault register is addressed by reading out FEFFH.



## 6.6 Technical Specifications of the Coordinators

### Important for the USA and Canada

The following approvals have been obtained for the modules listed in this chapter:



UL Listing Mark  
Underwriters Laboratories (UL) to  
Standard UL 508, Report E 85972



CSA Certification Mark  
Canadian Standard Association (CSA) to  
Standard C 22.2 No. 142, Report LR 63533C

	923A Coordinator	923C Coordinator
Type of protection	IP 00	
Operating temperature	0 to + 55 °C	
Transportation and storage temperature	- 40 to + 70 °C	
Relative humidity	95 % max. at + 25 °C, no condensation	
Operating altitude	3500 m max. above sea level	
Supply voltage	5 V ±5%	5 V ±5% 24 V +25%/-15%
Current consumption at 5 V	0.5 A typical	1.1 A typical
Current consumption at 24 V	—	60 mA
Minimum backup voltage	2.7 V	
Backup current	100 nA typical	2 µA typical
Acknowledgement time for access to communication memory via S5 Bus	320 ns typical	
Transmission rate of the serial interface	—	9600 bps
Transmission cable	—	Shielded 4-wire line, PG connecting cable
Transmission range	—	1 km max. at 9600 bps
Weight	Approx. 0.3 kg	
Dimensions (W x H x D)	20.32 x 233.4 x 160 mm	

# Interface Modules

# 7

## Contents of Chapter 7

7	Interface Modules .....	7 - 3
7.1	The 300 and 312 Interface Modules .....	7 - 4
7.1.1	Indicators and Controls .....	7 - 6
7.1.2	Modes/Jumper Assignments of the IM 300 .....	7 - 7
7.2	The 301 and 310 Interface Modules .....	7 - 11
7.2.1	Indicators and Controls .....	7 - 12
7.2.2	Modes/Jumper Assignments of the IM 301 .....	7 - 13
7.3	The 304 and 314 Interface Modules .....	7 - 15
7.3.1	Indicators and Controls .....	7 - 16
7.3.2	Modes/Jumper Assignments of the IM 304 .....	7 - 17
7.3.3	Modes/Jumper Assignments of the IM 314 .....	7 - 19
7.4	Technical Specifications .....	7 - 22
7.4.1	6ES5 721 Connecting Cable .....	7 - 23
7.4.2	6ES5 760 Terminator .....	7 - 24

# Interface Modules

# 7

Various interface modules (IMs) are available for communication between a central controller and expansion units, and between expansion units. Interface modules in the central controller are known as EU interface modules; those inserted in an EU are known as CC interface modules.

This chapter describes the EU interface modules:

- IM 300-3, IM 300-5, IM 301-3, IM 301-5 and IM 304

as well as the CC interface modules:

- IM 312-3, IM 312-5, IM 310 and IM 314

Other IMs such as the IM 307-IM 317 and the IM 308-IM 318 are described in separate manuals (see Catalog ST 54.1). The IM 306 CC interface module is described in the S5-115U PLC manual.

A general overview of the applications of individual IMs can be found in Chapter 2: "Centralized and Distributed Configuration of a Programmable Controller".

## 7.1 The 300 and 312 Interface Modules

The 300 and 312 interface modules are used for **centralized** connection of I/O modules and signal preprocessing modules (IPs) to a CC via the following expansion units (allowing for possible configurations):

- EU 183U
- EU 184U
- EU 185U (only input/output modules)
- EU 187U
- ER 701-1

Additionally, you can utilize these IMs for secondary communication, i.e. additional EUs can be connected in a centralized arrangement to an EU 183U or EU 185U in distributed configuration. Up to four IM 300s can be used in one CC, up to two of which may be IM 300-5s. You can use one IM 300 in an EU 183U or EU 185U.

### Application of the IM 300 and IM 312

An IM 300 EU interface module is complemented by an IM 312 or IM 306 CC interface module. Use the following IMs, depending on the connected EU:

EU Interface Module	EU Type	CC Interface Module
IM 300-5 C (6ES5 300-5CA11)	EU 184U, EU 187U	IM 312-5
IM 300-3 (6ES5 300-3AB11)	EU 183U EU 185U (only I/O modules)	IM 312-3
IM 300-5 L (6ES5 300-5LB11)	ER 701-1	IM 306

There are two versions of IM 312-3 and IM 312-5. They differ in the length of permanently connected cable:

Order No.	Cable Length
6ES5 312-5CA1X	0.5 m
6ES5 312-5CA2X	1.5 m
6ES5 312-3AB1X	0.5 m
6ES5 312-3AB3X	0.95 m

*Connecting the EU 184U and EU 187U*

For one IM 300-5, you can connect up to three EUs to a CC or EU in distributed arrangement (see Figures 7-5 and 7-6). The EUs are supplied with operating voltage via the IMs. The last IM 312-5 requires no terminator.

**Note**

**The maximum permissible current over each connection of the IM 300-5CA11 is 5 A.**

*Connecting the EU 183U, EU 185U*

You can connect up to four EUs to each IM 300-3. The last IM 312-3 requires a terminator.

*Connecting the ER 701-1*

You can connect up to three ERs to each IM 300-5L (-5LB11). The ERs are supplied with operating voltage via the IMs.

**Note**

**The maximum permissible current over each connection of the IM 300-5LB11 is 2 A.**

The connection of central controller and expansion unit to the IM 300-5LB11 is provided exclusively by the 705-0 connecting cable. It is available in two lengths: 0.5 m and 1.5 m (refer to the ordering information for order numbers).

7

*Addressing*

When the IM 300s are used in the S5-135U/155U PLC, the input/output modules can be addressed in the normal (P) and extended (O) areas.

You may only set module addresses in the EU which are not used in the CC. This applies to both areas.

### 7.1.1 Indicators and Controls

#### IM 300-3:

##### I/O Module Failure LED

This LED lights up if the supply of power to the connected EUs has failed and/or the connecting cable is open-circuit.

#### IM 300-5 (-5CA11):

##### I/O Module Failure LEDs

LEDs LD1 and/or LD2 light up if a module inserted in the EU no longer responds to an access by the CPU.

The IM 312 has no indicators or controls.

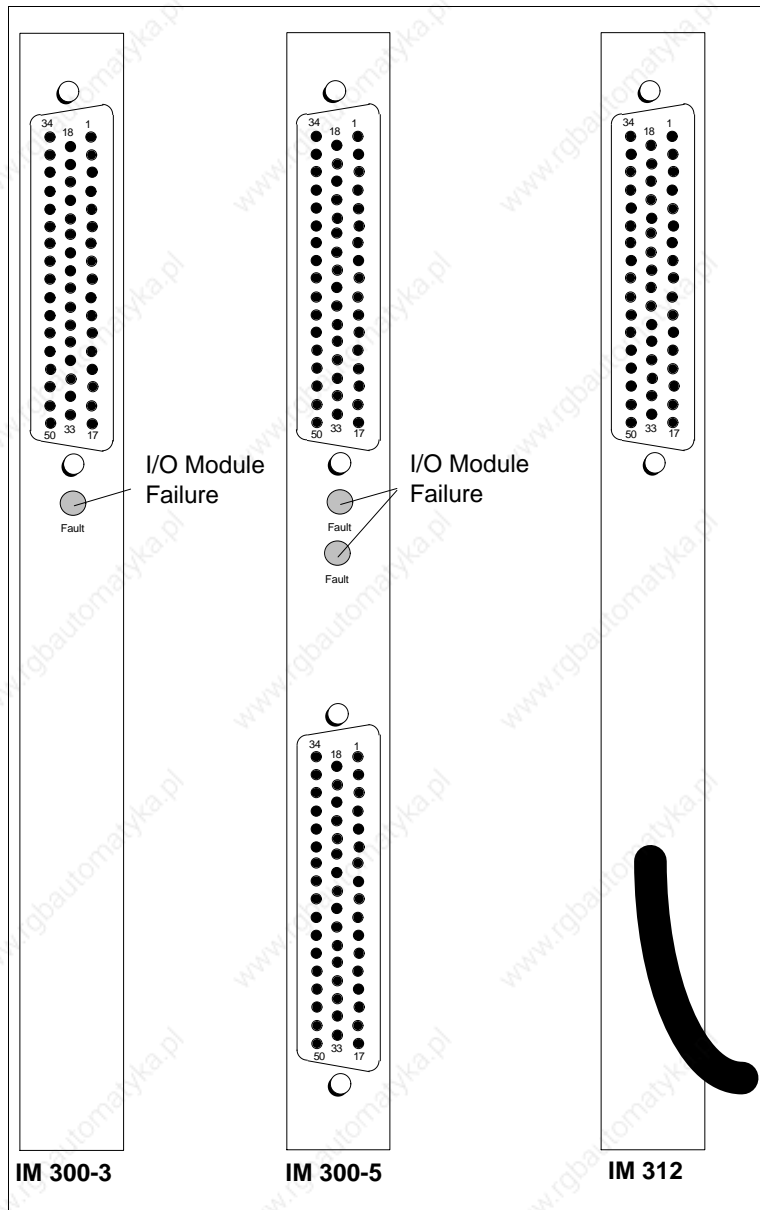
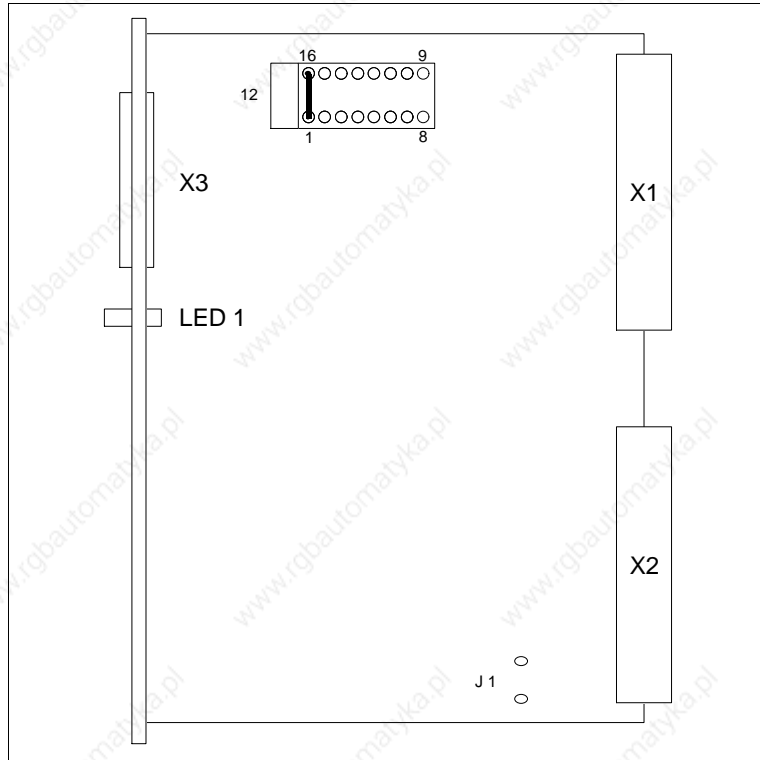

Figure 7-1 Front Plates of the IM 300 and IM 312

**7.1.2  
Modes/Jumper  
Assignments of the  
IM 300**

*Jumper assignments*

**IM 300-3**



**7**

Figure 7-2 Locations of Jumpers on the IM 300-3 (when Delivered)

*Purpose of the jumpers*

You must insert an additional jumper 4-13 at location 12 for address setting in the extended I/O area (O area).

Jumper 1 is open and has no function for operation in the S5-135U/155U PLC.

Jumper assignments

IM 300-5 (-5CA11)

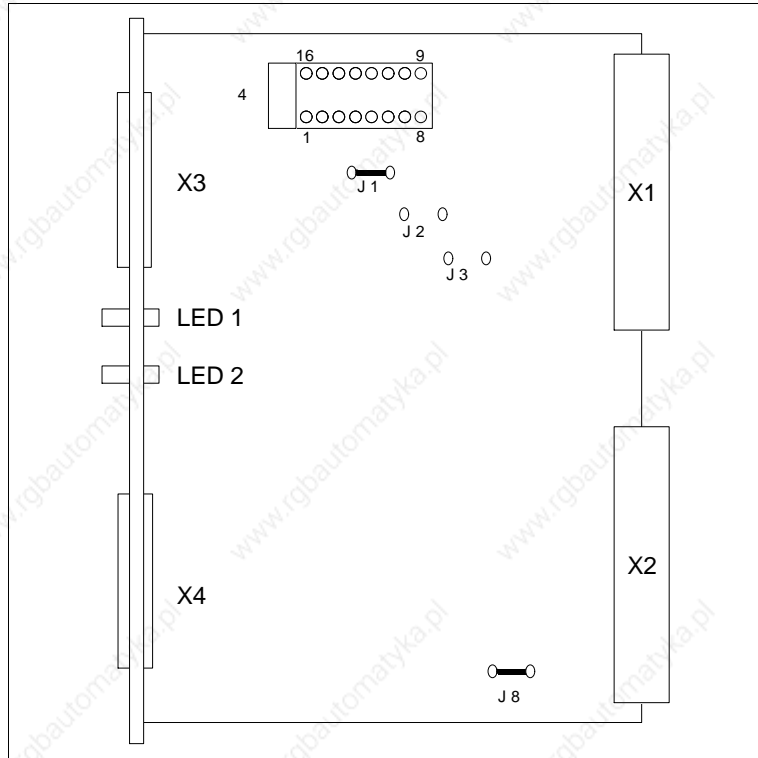

Figure 7-3 Locations of Jumpers on the IM 300-5 (-5CA11) (when Delivered)

You must insert jumper 8-9 at location 4 for address setting in the extended I/O area (O area). All other jumpers must remain in their factory settings.



## Jumper assignments

## IM 300-5 (-LB11)

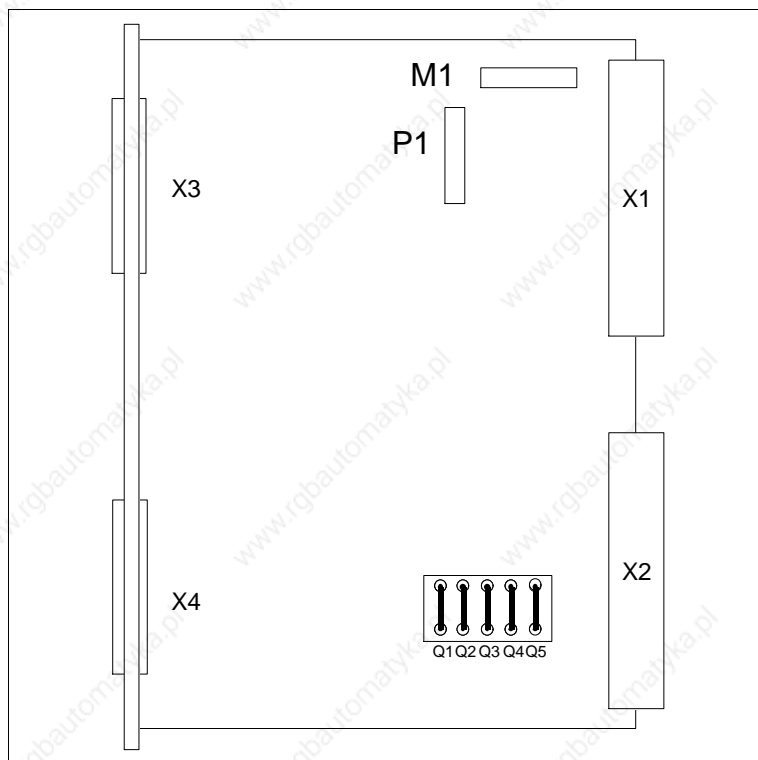

Figure 7-4 Locations of Jumpers on the IM 300-5 (-LB11)  
(when Delivered)

You must insert jumpers Q1 to Q4 for addressing in the normal (P) area.

If you insert jumper Q5, the "I/Os not ready" message will be relayed to the CPU.

All other jumpers must remain in their factory settings.

Shown in the following figures is the centralized communication between central controller and expansion units, with and without supply of power via the IM 300 and IM 312.

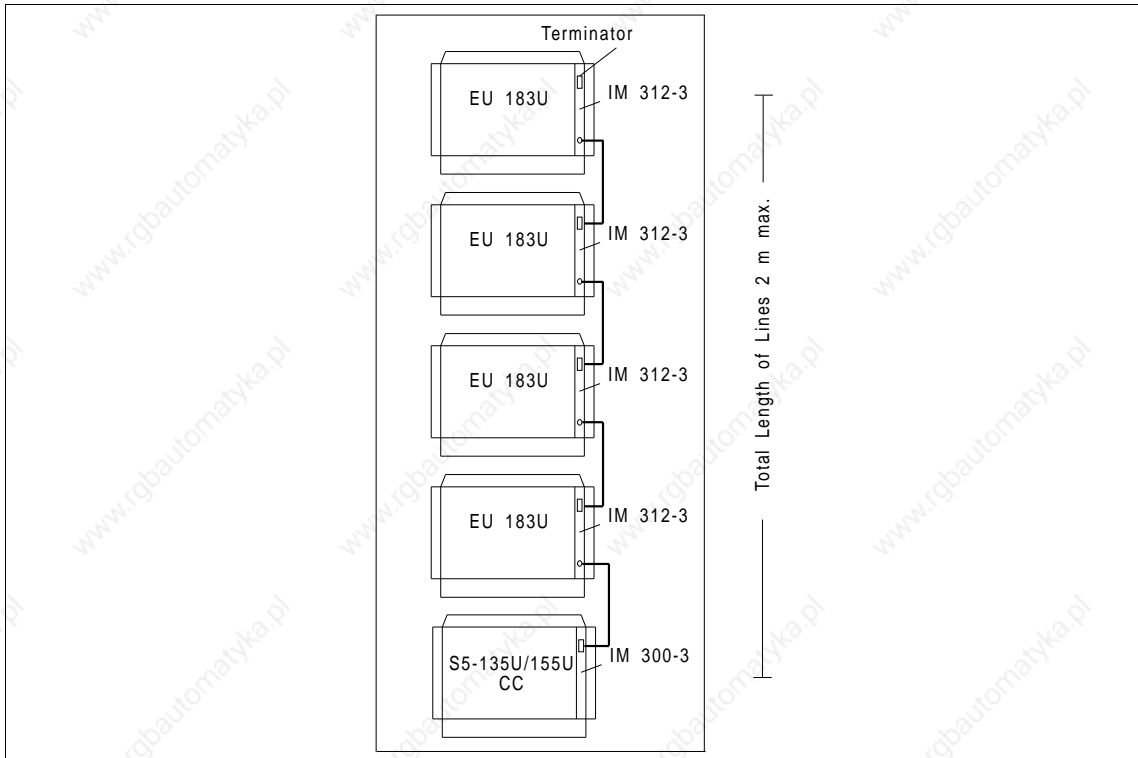

Figure 7-5 Centralized Communication Between Central Controller and Expansion Units with a Power Supply Unit

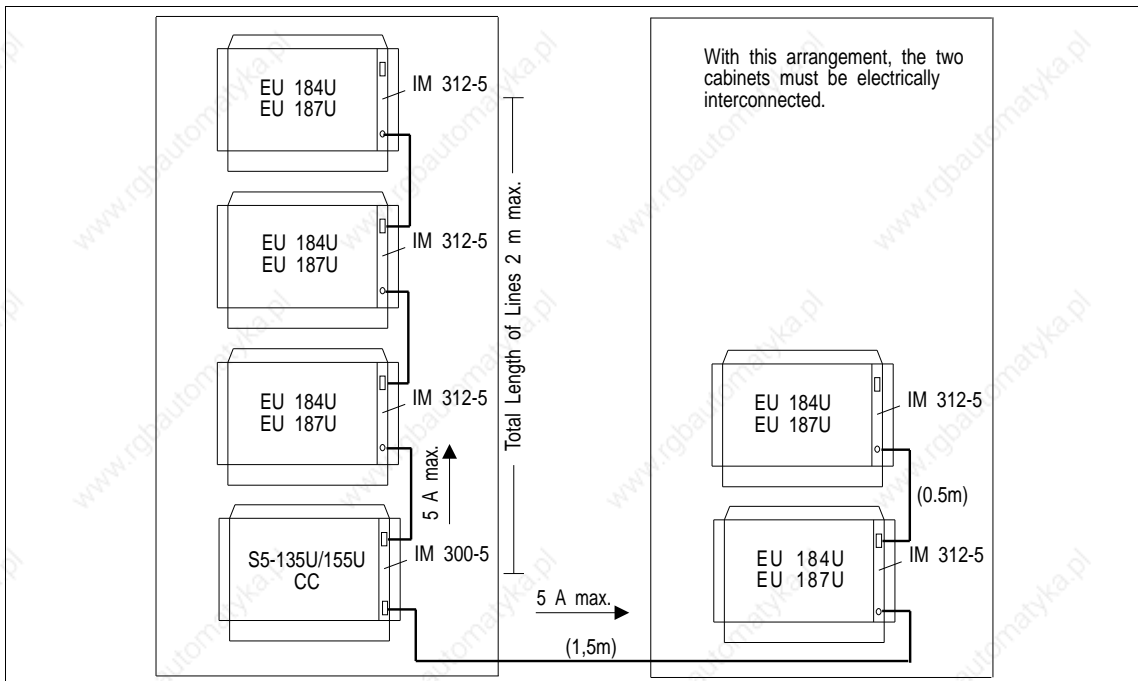

Figure 7-6 Centralized Communication Between Central Controller and Expansion Units without a Power Supply Unit

The EU with the highest current consumption should be positioned as closely as possible to the CC.

## 7.2 The 301 and 310 Interface Modules

The IM 301 is used to connect I/O modules and signal preprocessing modules (IPs) to a CC in a **distributed** arrangement (allowing for possible configurations) via an

- EU 183U
- EU 185U (only input/output modules)

expansion unit.

You can connect up to four EUs to a CC in distributed arrangement via the IM 301. If you use the 721 connecting cable, the total cable length from the CC to the last EU may be up to 200 m. The distributed connection is made via the lower front connector of the module. Use the IM 310 interface module in the EU to be connected in a distributed arrangement:

EU Interface Module	EU Type	CC Interface Module
IM 301	EU 183U, EU 185U (only I/O modules)	IM 310

7

Apart from the distributed EUs, you can connect the following expansion units in a **centralized** arrangement:

- EU 183U
- EU 184U
- EU 187U

The centralized connection is made via the upper front connector of the module. Use the following interface modules, according to the EU to be connected in a centralized arrangement:

EU Interface Module	EU Type	CC Interface Module
IM 301-5	EU 184U, EU 187U	IM 312-5
IM 301-3	EU 183U	IM 312-3

Unused centralized connections of the IM 301-3 and unused distributed connections of the IM 301-3 and IM 301-5 must be terminated with terminators. The same applies to the last IM 310.

You may only set module addresses in the EU which you are not yet using in the CC. This applies to the normal (P) and extended (O) areas.

### 7.2.1 Indicators and Controls

#### IM 301:

##### Fault LEDs

When the CPU is restarted, the red LED 1 and/or LED 2 lights up if the internal supply voltage (5 V DC) or external load voltage (24 V DC) fails.

The IM 310 has no indicators or controls.

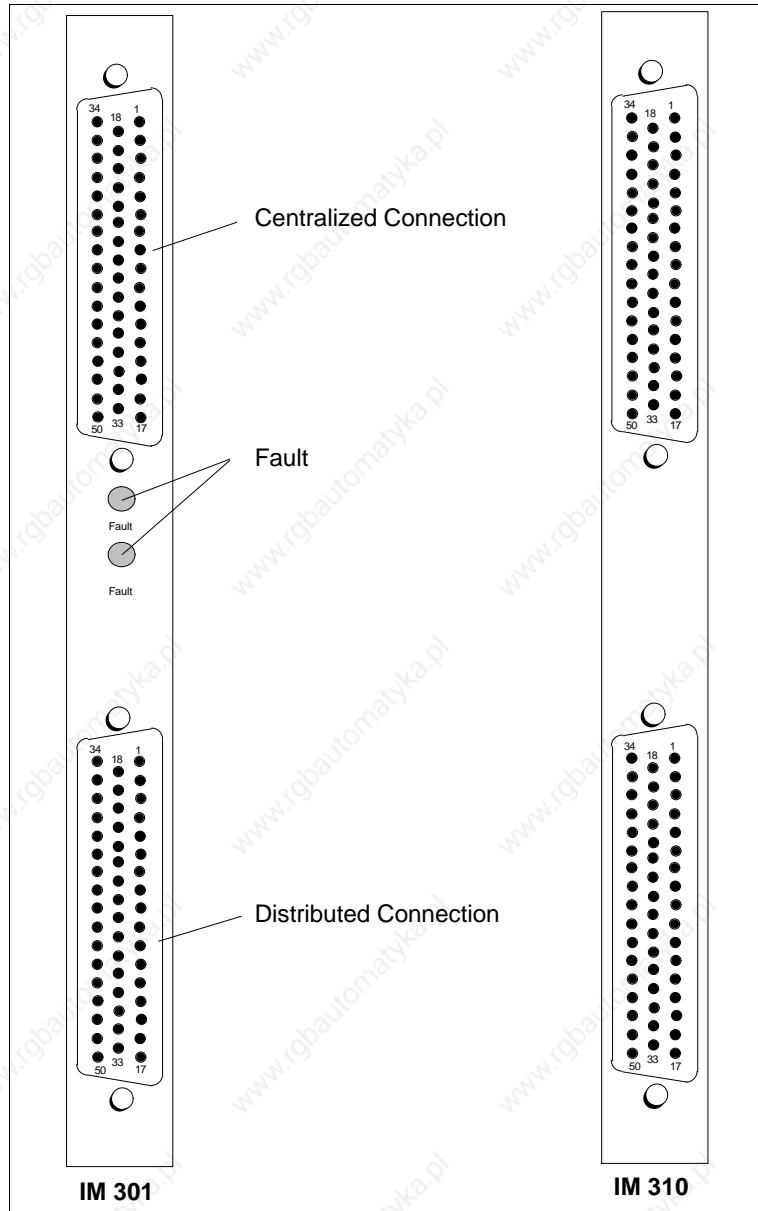

Figure 7-7 Front Plates of the IM 301 and IM 310

**7.2.2**  
**Modes/Jumper**  
**Assignments of the IM 301**

*Jumper assignments*

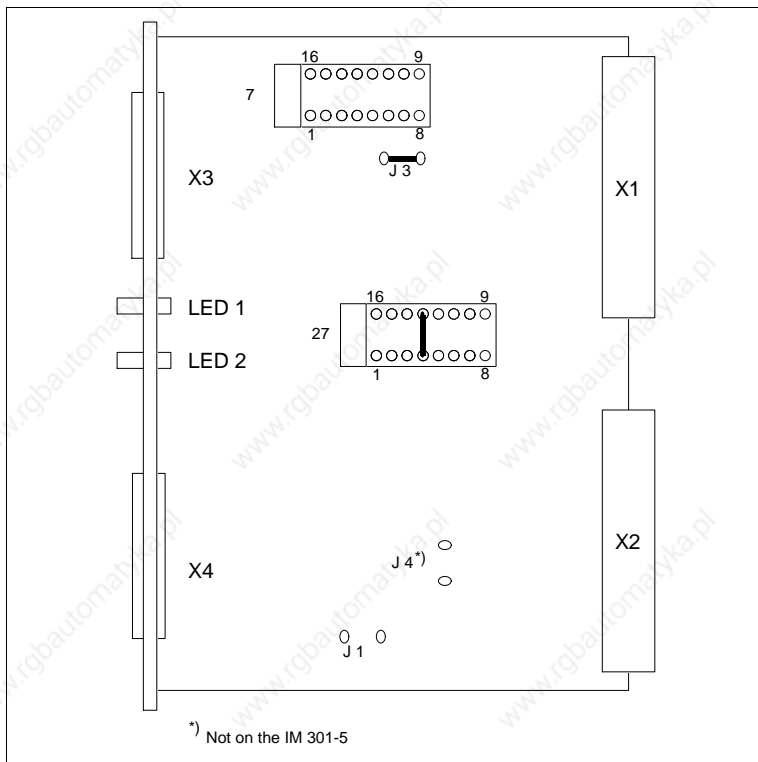

Figure 7-8 Locations of Jumpers on the IM 301 (when Delivered)

You must insert jumper 8-9 at location 7 for address setting on the extended I/O area (O area). All other jumpers must remain in the factory settings.

If you insert jumper 4, the "I/Os not ready" message will be relayed to the CPU.

The following figures show distributed communication between central controller and expansion units via the IM 301 and IM 310.

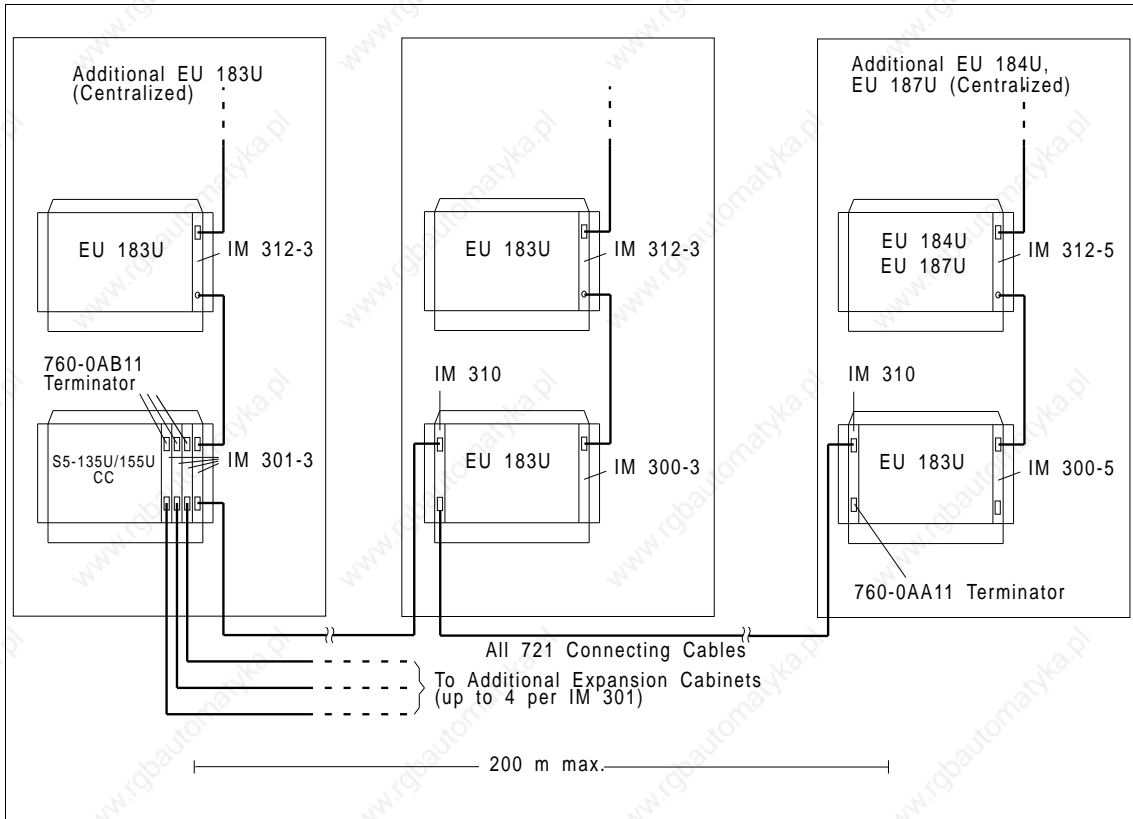

Figure 7-9 Connection of EU 183Us to the Central Controller via the IM 301-3

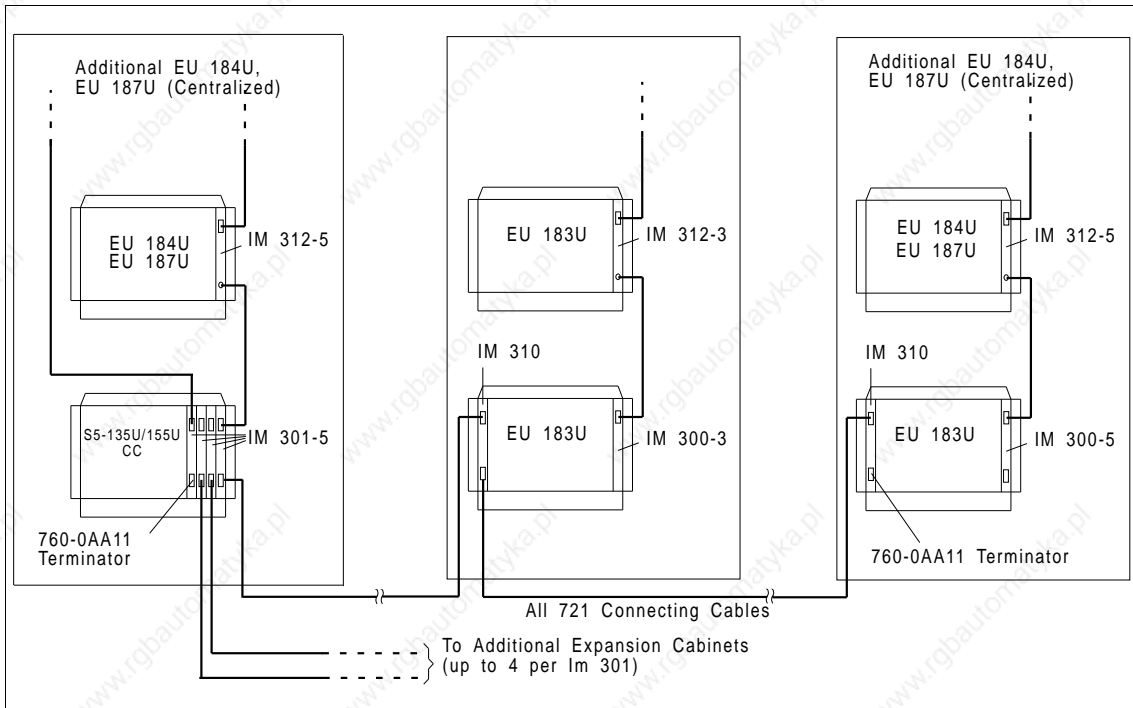

Figure 7-10 Connection of EU 184U/EU 187Us to the Central Controller via the IM 301-5

### 7.3 The 304 and 314 Interface Modules

The IM 304 and IM 314 are used to connect I/O modules, signal preprocessing modules (IPs) and communication processors (CPs) to a CC in a **distributed** arrangement via the

- EU 185U
- ER 701-3

expansion units.

You can also use the IM 304 and IM 314 to connect I/O modules to a CC in a distributed arrangement via the

- EU 183U
- ER 701-2

expansion units.

#### Line length

You can connect up to two-times four EUs in a distributed arrangement via one IM 304. If you utilize the 721 connecting cable, the total line length from the CC to the last EU may be 600 m per run. You can connect additional EUs in a centralized arrangement to the distributed EUs.

You can insert up to four IM 304s in one CC.

The IM 304 EU interface module is complemented by the IM 314 CC interface module. In fault-tolerant systems, you must use the IM 314R CC interface module together with the IM 304 (refer to the S5-155H manual).

EU Type	EU Interface Module	CC Interface Module
EU 183U EU 185U ER 701-2 ER 701-3	IM 304	IM 314

You may only set module addresses in the EU which you do not use in the CC. This also applies when the EU is addressed in the extended (O) area, IM3 area or IM4 area.

### 7.3.1 Indicators and Controls

#### Fault LEDs

A FAULT LED lights up

- if the power supply fails in an expansion unit;
- if there is no terminator at the last IM 314;
- in the event of a cable open-circuit or wrong setting of DIL switch S3 for the IM 304,
- or if an EU which is ready and operational is connected to an interface which is switched off.

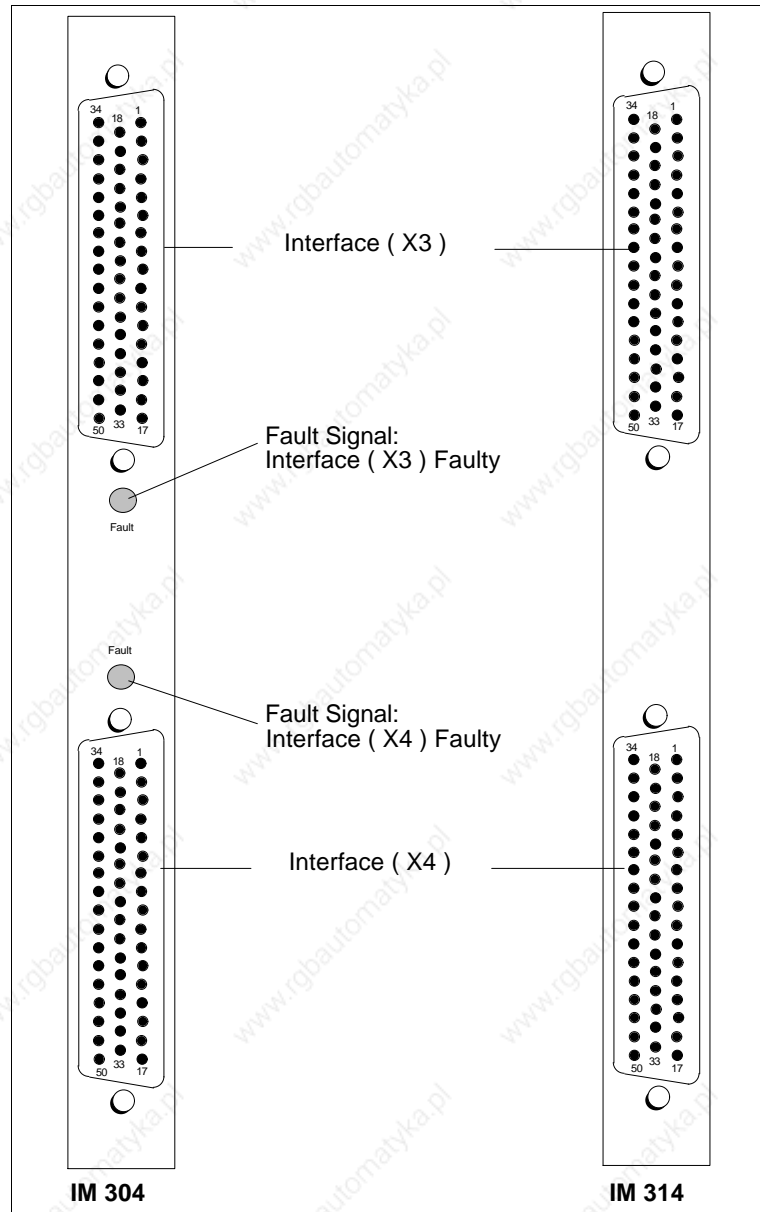

Figure 7-11 Front Plates of the IM 304 and IM 314



7.3.2

Modes/Jumper

Assignments of the IM 304

You must match the IM 304 to the cable length with jumper X11.

	Jumper Plug X 11				
Jumper Location					
Cable length	10 m max.	100 m max.	100 to 250 m	250 to 450 m	450 to 600 m

\*) This setting is only permissible for IM 304 - IM 324R communication in the S5-155H PLC.

The longest communication path, i.e. the sum of cable lengths at interface of X3 or X4, is governed by the location of jumper X11.

Jumper assignments

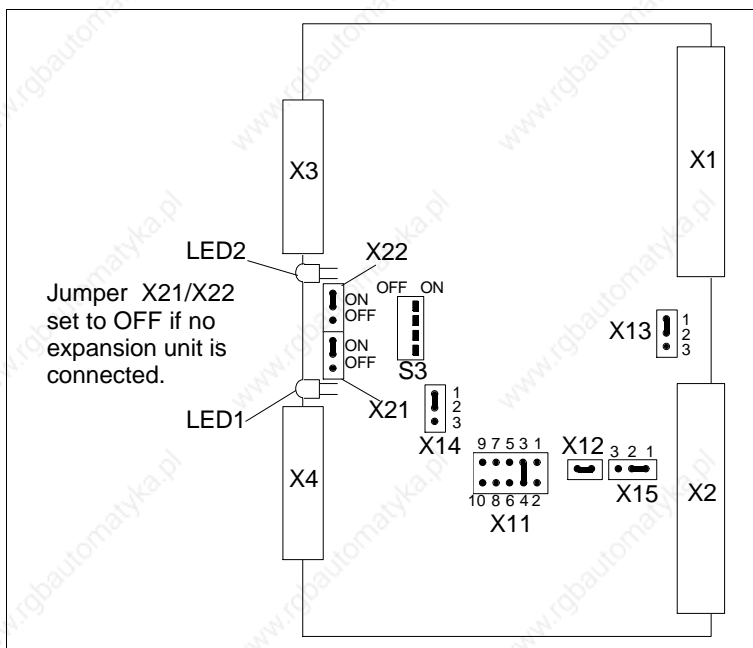
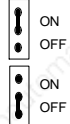

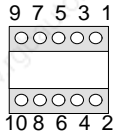

Figure 7-12 Locations of Jumpers on the IM 304 (when Delivered)

Purpose of the jumpers

Function	Jumper Settings
Interface X3/X4 - Switched on - Switched off <sup>1)</sup>	X22/X21 at "ON" X22/X21 at "OFF" 
"I/Os not ready" message relayed -no -yes	X15 no jumpers X15 jumper 1-2 
"I/Os not ready" message when - 1 interface not ready - 2 interfaces not ready	X14 jumper 1-2 X14 jumper 2-3 
Set cable length between 304/314 - 0 to 100 m - 100 to 250 m - 250 to 450 m - 450 to 600 m	X11 Jumper 3-4 Jumper 5-6 Jumper 7-8 Jumper 9-10 

<sup>1)</sup> Jumper X22 is assigned to interface X3.  
 Jumper X21 is assigned to interface X4

All other jumpers and switches must remain at the factory settings.

**7.3.3**  
**Modes/Jumper**  
**Assignments of the IM 314**

*Jumper assignments*

Set the jumpers according to the EU in use.

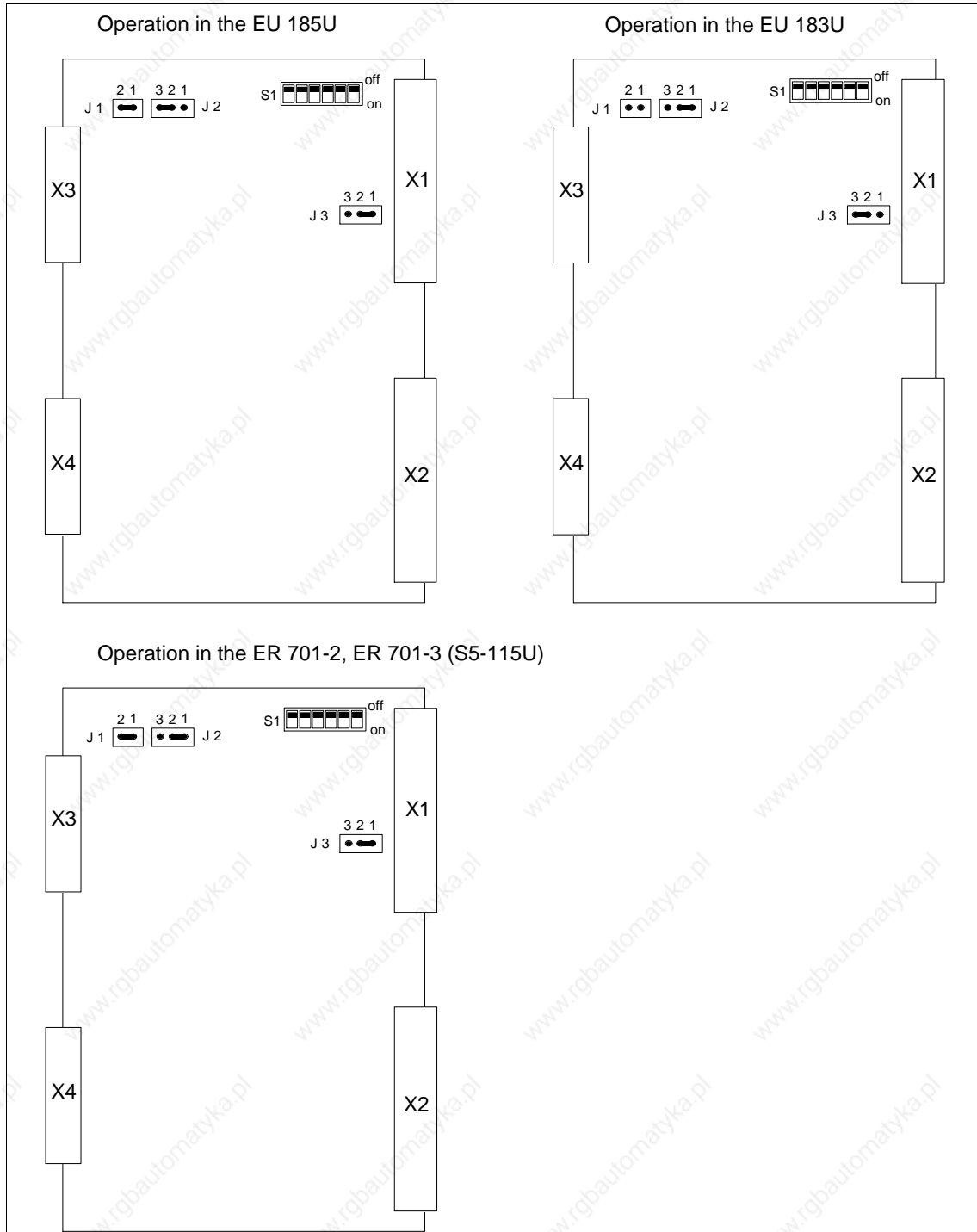
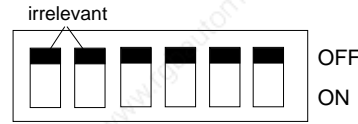

Figure 7-13 Locations of Jumpers on the IM 314

Setting the addresses

I/O Area Address	Switch Setting
P area:F000 - F0FF O area:F100 - F1FF  IM3 area:FC00 - FCFF  IM4 area:FD00 - FDFF	0 = OFF, 1 = ON  S1:0000 *) 0001  1100  1101



\*) Factory setting

The I/O area address is set on the IM 314. This setting applies only to the digital and analog I/O modules.

Address areas P, O, IM3 and IM4 are available. To address the digital and analog I/O modules in these areas, set the switches by depressing the individual rockers.

In the STEP 5 standard operation set, you only address the P and O areas.

Module addresses used in the CC cannot be used in the EU in the P area, O area, IM3 area and IM4 area.

If you do not insert I/O modules in the central controller, an address space of 256 bytes is available in each I/O area for input/output addresses.

The following figure shows communication between the central controller and expansion units via the IM 304 and IM 314.

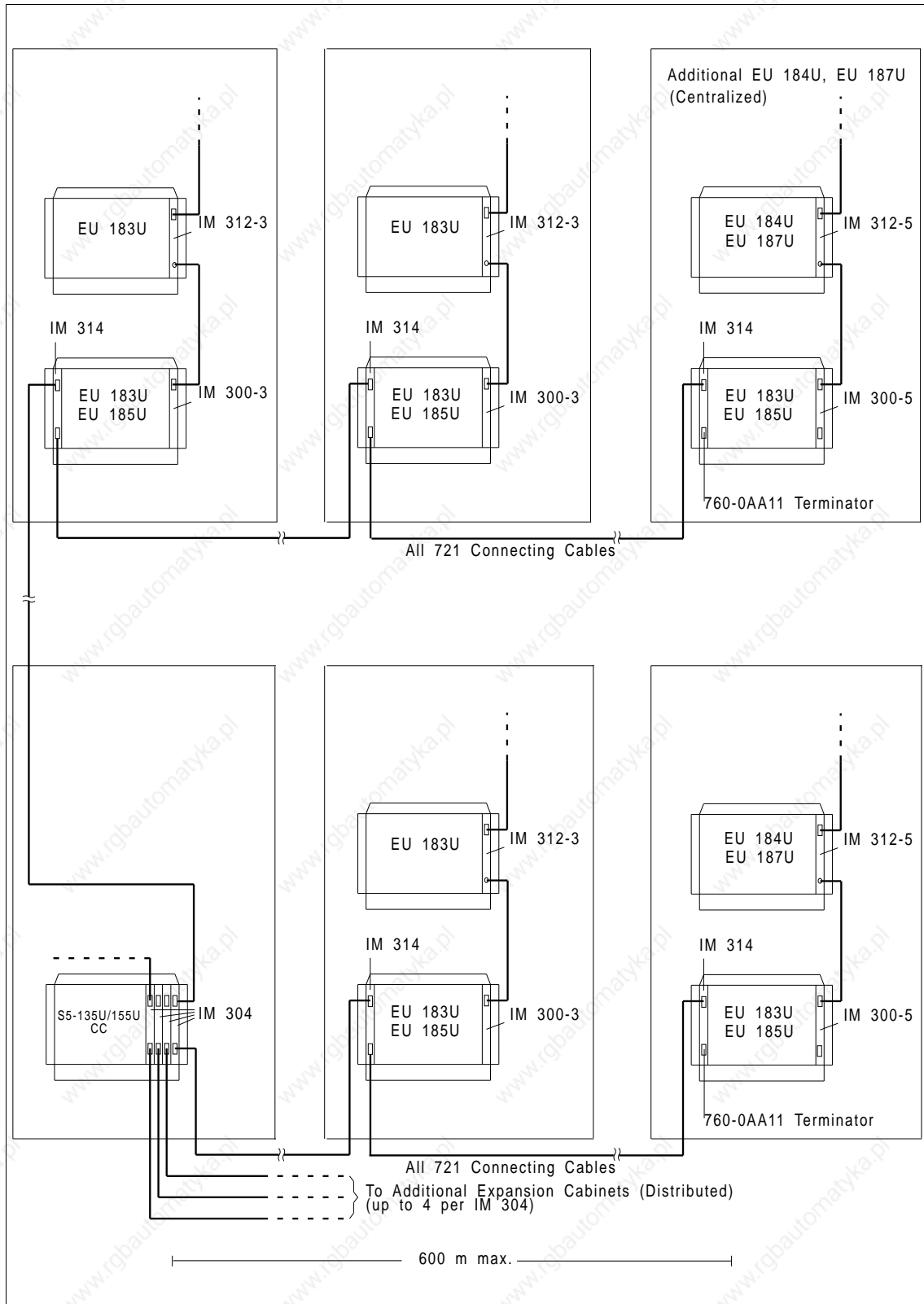

Figure 7-14 Communication Between Central Controller and Expansion Units via the IM 304/IM 314

## 7.4 Technical Specifications

### Important for the USA and Canada

The following approvals have been obtained for the modules listed in this chapter:



UL Listing Mark  
Underwriters Laboratories (UL) to  
Standard UL 508, Report E85972 and E116536 for the  
IM 300-5LB11



CSA Certification Mark  
Canadian Standard Association (CSA) to Standard  
C 22.2 No. 142, Report LR 63533C and LR 48323 for  
the IM 300-5LB11

Given in the following are the technical specifications of the IMs and pin assignments of the connecting cable and terminator.

General Specifications	
Type of protection	IP 20
Insulation class	C to VDE 0160
Operating temperature	0 to 55 °C
Transportation and storage temperature	- 40 to 70 °C
Relative humidity	95 % max. at 25 °C, no condensation
Mechanical requirements	See description of central controllers
Supply voltage (internal)	5 V ± 5 %

Specifications for Specific IMs									
Interface module	IM 300	IM 300 (-5CA)	IM 300 (-5LB)	IM 301 (-5CA)	IM 301 (-3AB)	IM 304	IM 310	IM 312	IM 314
Max. current consumption	0.6 A	0.6 A	50 mA	0.75 A	0.75 A	1.2 A	0.7 A	0.2 A	1.0 A
Max. current per interface	-	5 A	2 A	5 A	-	-	-	-	-
Weight, approx.	0.35 kg	0.35 kg	0.25 kg	0.3 kg	0.3 kg	0.35 kg	0.3 kg	0.35 kg	0.3 kg

7.4.1

**6ES5 721 Connecting Cable** The 6ES5-721-xxx connecting cable is intended for interconnection of the CC/EUs. Refer to the catalog for the SIMATIC length codes.

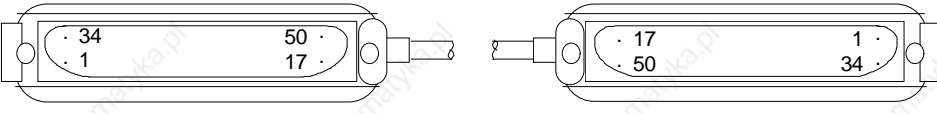

Connector 50-Way Terminal	Bundle ID Sheath	ID Foil	Core Color	Connector 50-Way Terminal
20	1 Red No. 16	rd	wh	20
21			br	21
4			gn	4
5			ye	5
18			gr	18
19			pk	19
2	2 Green No. 17	gn	bl	2
3			rd	3
24			wh	24
25			br	25
8			gn	8
9			ye	9
22	gr	22		
23	pk	23		
6	3 Yellow No. 18	wh	bl	6
7			rd	7
26			wh	26
27			br	27
10			gn	10
11			ye	11
42	gr	42		
43	pk	43		
44	bl	44		
45	rd	45		
28	4 Brown No. 19	wh	wh	28
29			br	29
12			gn	12
13			ye	13
46			gr	46
47			pk	47
30	bl	30		
31	rd	31		
34	5 Black No. 20	ws	wh	34
35			br	35
36			gn	36
37			ye	37
38			gr	38
39			pk	39
40	bl	40		
41	rd	41		
48	6 Blue No. 21	rd	wh	48
49			br	49
14			gn	14
15			ye	15
32			gr	32
33			pk	33
-	Shield			-

Figure 7-15 Conductor Assignments of the 721 Connecting Cable

**7.4.2**  
**6ES5 760 Terminator**

The IM 314 of the last expansion unit of each run is terminated with the 6ES5 760-1AA11 terminator. The IM 312 and IM 301-3 (with a free centralized connection) is terminated with the 6ES5 760-0AB11 terminator. The IM 301-3 (with a free distributed connection) is terminated with the 6ES5 760-0AA11 terminator.

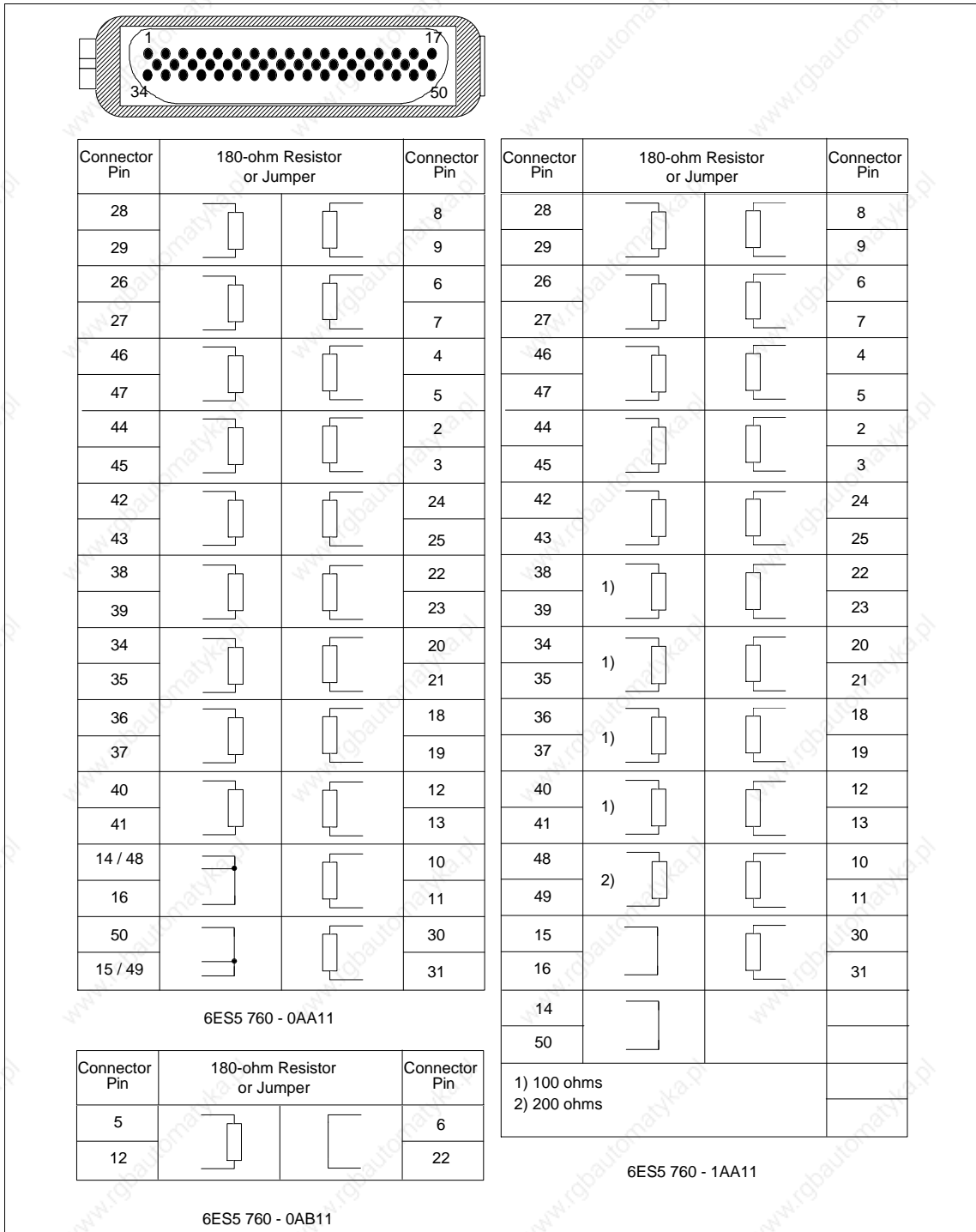

Figure 7-16 Pin Assignments of the 760 Terminator



# Digital Input/Output Modules

# 8

## Contents of Chapter 8

8	Digital Input/Output Modules .....	8 - 3
8.1	Technical Description .....	8 - 4
8.1.1	Design .....	8 - 6
8.1.2	Function of the Enable Inputs .....	8 - 6
8.1.3	Special Features of the 432 Digital Input Module .....	8 - 10
	Operation without process alarm .....	8 - 10
	Operation with process alarm via interrupt .....	8 - 11
	Operation with process alarm via IB 0 .....	8 - 12
8.1.4	Special Features of the DI/DQ 482 .....	8 - 15
8.2	Installation and Startup .....	8 - 17
8.2.1	Setting the Module Address .....	8 - 17
8.2.2	Removing and Inserting Modules .....	8 - 21
8.2.3	Marking of Modules .....	8 - 23
8.2.4	Connecting the Signal Lines .....	8 - 24
8.2.5	Connection of Outputs in Parallel and Switching On the Load via a Contact .....	8 - 25
8.2.6	Short-Circuit Protection and Fusing .....	8 - 27
8.2.7	Arc-Quenching for Inductive Loads .....	8 - 28
8.3	Common Technical Specifications .....	8 - 31
8.4	Specification Sheets for the Modules .....	8 - 33
8.4.1	6ES5 420-4UA13 Digital Input Module .....	8 - 33
8.4.2	6ES5 430-4UA13 Digital Input Module .....	8 - 35
8.4.3	6ES5 431-4UA12 Digital Input Module .....	8 - 37
8.4.4	6ES5 432-4UA12 Digital Input Module .....	8 - 39
8.4.5	6ES5 434-4UA12 Digital Input Module .....	8 - 42
8.4.6	6ES5 435-4UA12 Digital Input Module .....	8 - 45

## Contents

---

8.4.7	6ES5 436-4UA12 Digital Input Module .....	8 - 47
8.4.8	6ES5 436-4UB12 Digital Input Module .....	8 - 49
8.4.9	6ES5 441-4UA13 Digital Output Module.....	8 - 51
8.4.10	6ES5 451-4UA13 Digital Output Module.....	8 - 53
8.4.11	6ES5 453-4UA12 Digital Output Module.....	8 - 55
8.4.12	6ES5 454-4UA13 Digital Output Module.....	8 - 57
8.4.13	6ES5 455-4UA12 Digital Output Module.....	8 - 59
8.4.14	6ES5 456-4UA12 Digital Output Module.....	8 - 61
8.4.15	6ES5 456-4UB12 Digital Output Module.....	8 - 63
8.4.16	6ES5 457-4UA12 Digital Output Module.....	8 - 65
8.4.17	6ES5 458-4UA12 Digital Output Module.....	8 - 67
8.4.18	6ES5 458-4UC11 Digital Output Module.....	8 - 70
8.4.19	6ES5 482-4UA11 Digital Input/Output Module.....	8 - 72

# Digital Input/Output Modules

# 8

Described in this chapter are the installation, wiring and operation of digital input modules and digital output modules. The 432 digital input module and the 482 digital input/output module have special features. These are discussed in separate sections. The technical specifications and front connector assignments for the individual modules are shown at the end of this chapter.

## 8.1 Technical Description

The description below applies to the following modules:

Type of Modules	Inputs/Outputs		Input/Output Current	Isolation/ Groups <sup>*)</sup>
	Number	Rated Voltage		
<b>Digital input modules</b>				
6ES5 420-4UA13	32	24 V DC	8.5 mA	no —
6ES5 430-4UA13	32	24 V DC	7.0 mA	yes 1
6ES5 431-4UA12	16	24 to 60 V DC	A4.5 to 7.5 mA	yes 16
6ES5 432-4UA12	32	24 V DC/alarm	8.5 mA	yes 4
6ES5 434-4UA12	32	5 to 15 V DC	1.3 mA	yes 1
6ES5 435-4UA12	16	24 to 60 V AC	15 to 25 mA	yes 2
6ES5 436-4UA12	16	115 to 230 V AC	15 to 25 mA	yes 2
6ES5 436-4UB12	8	115 to 230 V AC	15 to 25 mA	yes 8
<b>Digital output modules</b>				
6ES5 441-4UA13	32	24 V DC	0.5 A	no —
6ES5 451-4UA13	32	24 V DC	0.5 A	yes 1
6ES5 453-4UA12	16	24 V DC	2.0 A	yes 16
6ES5 454-4UA13	16	24 to 60 V AC	2.0 A	yes 1
6ES5 455-4UA12	16	115 to 230 V AC	2.0 A	yes 2
6ES5 456-4UA12	16	115 to 230 V AC	2.0 A	yes 2
6ES5 456-4UB12	8	24 to 60 V DC	2.0 A	yes 8
6ES5 457-4UA12	16	60 V relay	0.5 A	yes 16
6ES5 458-4UA12	16	250 V AC relay	0.5 A	yes 16
6ES5 458-4UC11	16		5 A	yes 2
<b>Digital input/output module</b>				
6ES5 482-4UA11	16 inputs and 16 outputs or 24 inputs and 8 outputs	24 V DC	8.5 mA (inputs) 0.5 A (outputs)	yes 1

<sup>\*)</sup> All inputs and outputs having a common 0 V ground form a group.

Technical specifications which are common to all modules are given in Section 8.3. The special technical specifications for all modules can be found in Section 8.4.

### I/O modules

Digital input and digital output modules are I/O modules which allow the processing of widely differing process signals with the S5-135U/155U programmable controller. They can also be used via an adapter casing in the S5-115U PLC.

*Digital input modules*

A digital input module converts the process signals to the internal signal level in the module. Interference is suppressed by the input circuitry, and the logic states at the inputs are indicated with LEDs on the front strip of the module. With most digital input modules (except the 420), the signals are isolated from the central ground point when received. Inputs relating to the same group are isolated from inputs of another group, but not from each other.

*Digital output modules*

The control signals processed in the PLC are output via digital output modules at a signal level suitable for the actuator, e.g. contactor, solenoid valve, etc. For the voltages and currents required in the process, modules with appropriate output circuitry are available.

With most digital output modules (except the 441), the signals are isolated from the central ground point when relayed to the outputs. Outputs relating to the same group are isolated from outputs of another group, but not from each other.

*BASP (output inhibit)*

If a digital output module receives a "command output inhibit" (BASP, cf. Programming Guide and Chapter 4) from the CPU, the outputs are set to zero.

When the supply voltage of the central controller or expansion unit has been switched on or when the CPU is at STOP, the outputs are set to zero.

*Signal output,  
short-circuit detection*

Signal output H+ on digital output modules for direct voltage emits a signal when a short-circuit to ground (L-) or overcurrent has been detected at one or more outputs currently at logic 1. Only short-circuits which are effective for more than 0.5 to 1 s are detected. Short-circuits are only detected at connected outputs. The signal outputs are decoupled by diodes. Up to 16 outputs can be connected in parallel. Ensure that isolation is not defeated by the parallel connection of outputs.

To ensure functioning of the signal output, you must connect terminal 1L+ to 24 V on the 441, 451 and 454 modules. On the 453 and 457 modules, the floating signal output must be powered separately.

### 8.1.1 Design

The modules are designed as plug-in PCBs for central controllers and expansion units with backplane connector and with a blade connector to accept a plug-in front connector. The front connector has screw or crimp terminals and is available separately; you can connect the process signal lines to it directly.

#### LED indicators

Fitted to each module is a strip with green LEDs to indicate the logic states of inputs or outputs. The LEDs are arranged in bytes and marked bit 0 to 7.

Output modules for direct voltage additionally have red LEDs to indicate short-circuits between output lines and ground (L-) within a group. Output modules for alternating voltage have red LEDs to indicate a fuse failure.

#### Addressing switch

Fitted on each module is an addressing switch with six, seven or eight rockers to set the module address.

The modules are protected on both sides by covers.

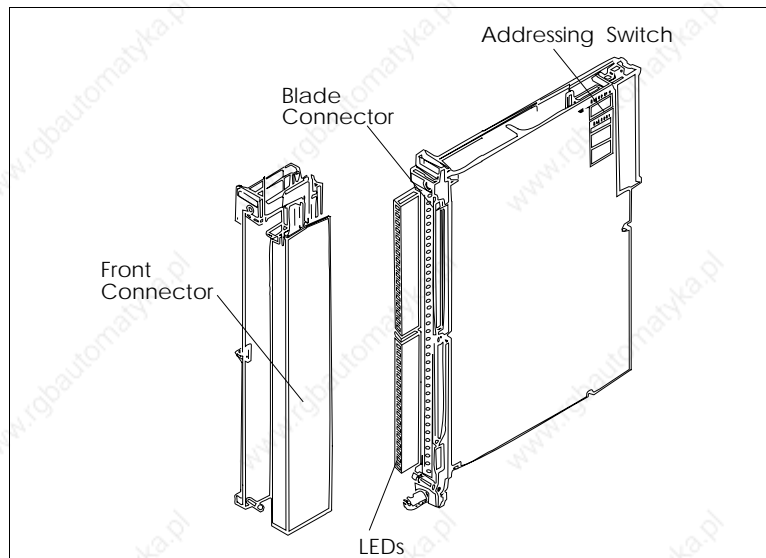

Figure 8-1 Digital Input Module

### 8.1.2 Function of the Enable Inputs

The digital input/output modules have an enable circuit. You can use the enable inputs to implement electrical interlocks for certain modules or switch off individual modules, whilst the PLC is in operation.

This means that:

- The module can no longer be addressed by the user program.
- All outputs of digital output modules are set to zero.

Modules which are switched off can be removed or inserted during operation. If this is not necessary, operate the module with the enable input switched off.

*With an active enable input*

On digital input/output modules with DC voltage inputs or outputs, the enable circuit requires that enable inputs F+ and F- be wired in the front connector. Enabling is achieved by applying an external voltage to inputs F+/F-. Modules for AC voltage have a wire jumper in the front connector.

When the front connector is swivelled away from the front strip of the module, the supply of power to the enable input is interrupted, i.e. the wire jumper in the front connector is removed; the module is switched off and can no longer be addressed by the user program.

When the front connector is swivelled away, i.e. the voltage is removed from the enable inputs, a timeout (QVZ) occurs at the CPU (see the Programming Guide for the particular CPU).

Apart from the 6ES5 458-4UC11 digital output module, all digital input/output modules additionally offer the facility for changing the enable mode. The modules have a jumper accessible from above in the vicinity of the addressing switch (see Figure 8-2).

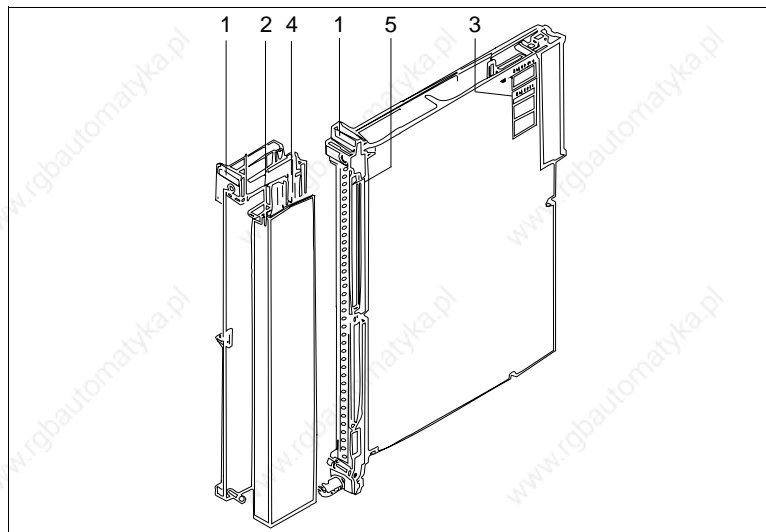

Figure 8-2 Location of the Enable Jumper

Jumper inserted: Enable input (F+/F-) active (factory setting)  
 Jumper open: Enable input (F+/F-) switched off

**With enable input switched off** If removal and insertion of modules during operation is not required, you must remove the plug-in jumper for changeover of the enable mode. Wiring of the enable inputs (F+/F-) can then be dispensed with.

**Examples of functioning of the enable inputs** Almost power-free shutdown of individual subprocesses, i.e. outputs of various modules can be operated from a common load supply and yet activated separately.

The load voltage of each individual module can be monitored without additional circuitry. Any reactions to failure of the load voltage can be programmed in the QVZ (timeout) organization block.

You must observe the following when configuring systems:

Switching on	At the latest 100 ms after power-up of the PLC, the voltage must be present at the enable inputs of the I/O modules.
Switching off	When the PLC has been switched off, the voltage at the enable inputs of the I/O modules must still be present as long as voltage is applied to the CC/EU.

You should observe the following instructions for switching off PLCs and equipment for supplying power to the enable inputs:

**24 V supply for CC/EU and I/Os**

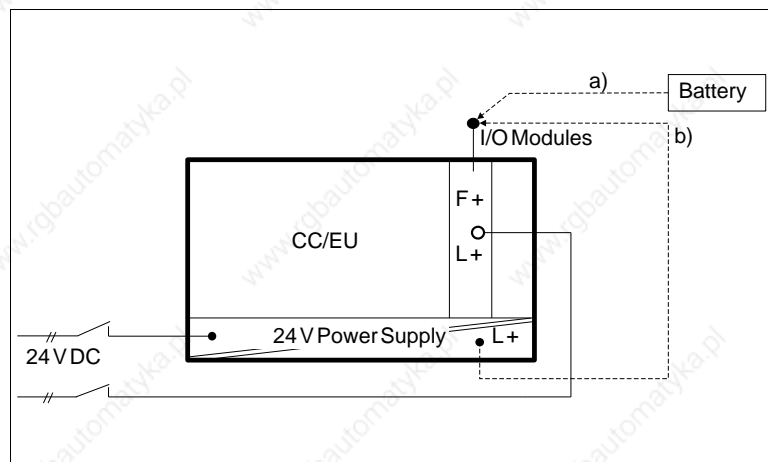

Enable supply from:

- a) Battery
- b) Terminals for 24 V on the front plate of the power supply



*Separate or common shutdown of the CC/EU and load power supply*

When there is a need to switch off the load power supply separately without affecting the enabling of modules, there are the following possibilities for producing the enable voltage. These exist even when the power supply is used without an additional capacitor and common shutdown.

**230 V AC supply for CC/EU and load power supply**

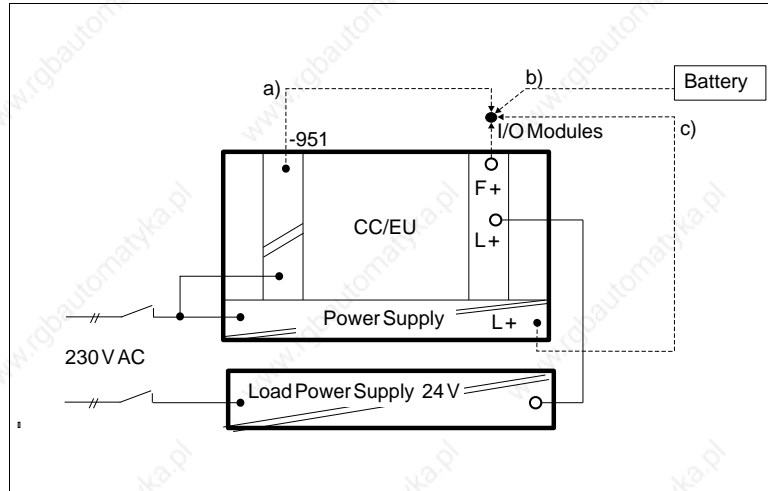

Enable supply from:

- a) 6ES5 951-4LB11 load power supply
- b) Battery
- c) Terminals for 24 V on the front plate of the power supply

*Common shutdown of the CC/EU and load power supply with a 230 V AC supply*

Proper functioning is ensured if the 24 V load power supply has an output capacitance of at least 4700  $\mu\text{F}$  per 10 A of load current.

Other units (load power supply for 20 or 40 A) which do not meet this condition can be adapted to this requirement by connecting a 10000  $\mu\text{F}$ /40 V capacitor in parallel.

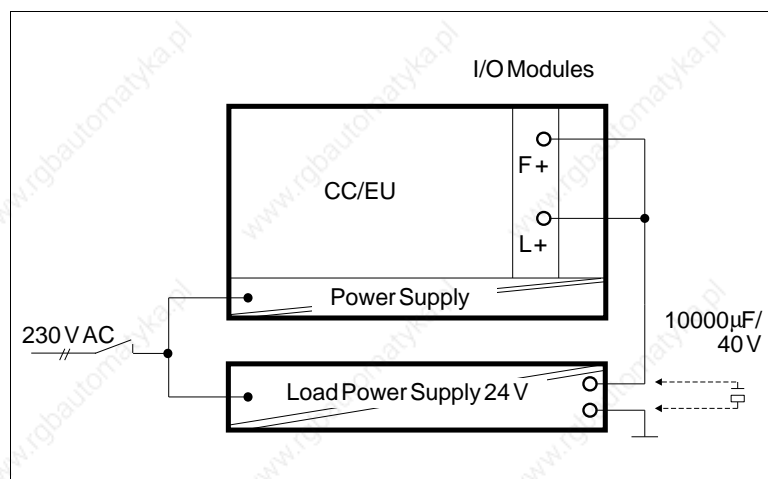

### 8.1.3 Special Features of the 432 Digital Input Module

The 432 digital input module accepts 32 process signals and emits a process alarm if the logic state at one of its inputs changes. You can operate the module in the following modes:

#### Modes

- without process alarm ("normal" digital input module)
- with initiation of a process alarm via interrupt
- with initiation of a process alarm via IB 0 (only in conjunction with CPU 948)

To operate the module with process alarm via IB 0, you must address it in the normal (P) area from byte 128 because

- the automatic updating of the process image might acknowledge a process alarm without the system program having detected and interpreted this alarm;
- only modules addressed in the normal (P) area can initiate a process alarm via IB 0.

#### Reaction time

The time for reaction of the module to a process alarm is mainly determined by the input circuitry. You can set the reaction time to one of the values 0.3 ms, 1 ms or 3 ms with switch S5. Note that the filtering effect decreases with shorter reaction times, and interference may be received as useful signals (effect of the line length, see the technical specifications).

#### Operation without process alarm

To operate the module without process alarm, you can insert it at any slot for I/O modules and address it in the entire I/O area. If you address it in the area PB/PY 0 to PB/PY 124, it will be within the automatic updating of the process image.

#### Settings on the module

Make the following settings on the module to operate it without process alarm:

Step	Action
1	Open jumpers X3 and X4
2	Set switch rows S1 and S2 to Off

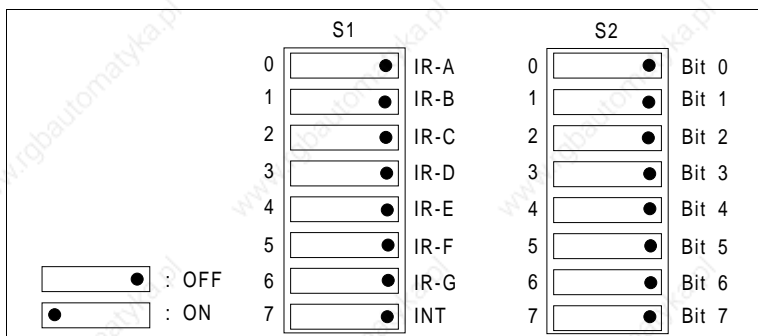

Figure 8-3 Switch Settings for Operation without Process Alarm

The setting for switch row S3 is arbitrary in this mode.

**Operation with process alarm via interrupt**

To operate the 432 digital input module with process alarm via an interrupt, you must either operate it in the CC where only certain slots have interrupt lines (see Chapter 4), or in an interrupt-capable EU connected to the CC with IM 307 - IM 317 interfacing (see also the IM 307 - IM 317 manual). In the CC, you may only operate the module in this mode at slots with an interrupt line (interrupt source).

So that the module can initiate a process alarm for a change of logic state, the alarm must be processed by an alarm routine (alarm OB) in the user program, with automatic acknowledgement of the alarm. To avoid loss of an alarm, it must not be possible for the alarm OB to be interrupted by process alarms. The CPU must process the process alarms with level triggering (see Programming Guide of the CPU).

**Scanning the process inputs**

**Example:**

Program the following operations in the corresponding alarm OB:

L	PW132	(load I/O word)
T	FW10	(transfer flag word)
L	PW134	etc.
T	FW12	

Only the flag word may be accessed during the cyclic program.

Accessing the I/O bytes in the process image will result in alarm loss. Addressing of the module must therefore be above address 127. Double accessing of I/O bytes, even from different CPUs, is not permissible (alarm loss).

The four I/O bytes of a module must be scanned successively and in ascending order. The scanning of byte n inhibits all input circuits of the module, and the scanning of byte (n + 3) enables them again.

Settings on the module

Make the following settings on the module to operate it with a process alarm via interrupt:

Step	Action
1	Open jumper X4 and close jumper X3.
2	Set the interrupt line at switch row S1: the switch relating to the desired interrupt line should be set to On. Set all other switches to Off.  You can set the same interrupt line on several modules.
3	Set switch row S2 to Off.
4	Set switch row S3 to choose whether the interrupt is to be initiated with a positive-going (leading) or negative-going (trailing) edge. The setting of a pair of switches applies to an entire byte.

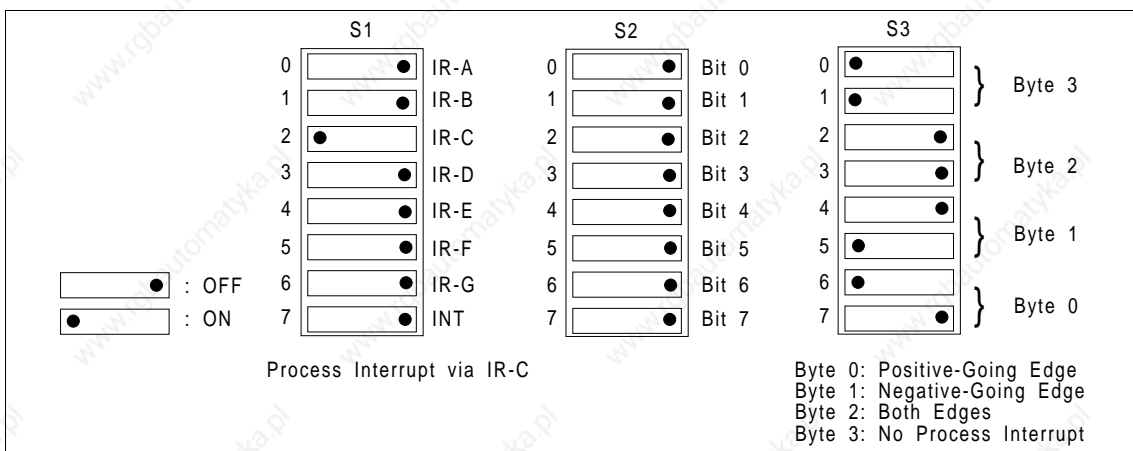

Figure 8-4 Switch Settings for Operation with Process Alarm via Interrupt (Example)

**Operation with process alarm via IB 0**

In this mode, a process alarm is initiated via input byte IB 0. This mode is only possible in conjunction with a CPU 948 in single-processor operation.

To operate the 432 digital input module with process alarm via IB 0, you can insert it at any I/O slot.

When you use the module in the CC, you must not set any other input module to address 0 (i.e. neither in the normal (P) nor in the extended (O) area).

If you use the module in an EU which is addressed in the normal area, you must not set any other input module in the EU to address 0 in the normal area.

So that the module can initiate a process alarm for a change of logic state, the alarm must be processed by an alarm routine (alarm OB) in the user program, with automatic acknowledgement of the alarm. To avoid loss of an alarm, it must not be possible for the alarm OB to be interrupted by process alarms. The CPU must process the process alarms with level triggering (see Programming Guide of the CPU).

*Scanning the process inputs*

**Example:**

Program the following in the alarm OB which you have preset with byte IB 0 and switch S2:

```
L    PW128    (load I/O word)
T    FW0      (transfer flag word)
L    PW130    etc.
T    FW2
```

Only the flag word (FW) may be accessed during the cyclic program.

Accessing the I/O bytes in the process image will result in alarm loss. Addressing of the module must therefore be above address 127. Double accessing of I/O bytes, even from different CPUs, is not permissible (alarm loss).

The four I/O bytes of a module must be scanned successively and in ascending order. The scanning of byte n inhibits the input circuit of the module, and the scanning of byte (n + 3) enables them again.

*Settings on the module*

Make the following settings on the module to operate it with a process alarm via IB 0:



Step	Action
1	Insert jumpers X3 and X4.
2	Set switch row S1 to Off.
3	Set bit 0 on switch row S2 to On, and all other switches to Off.
4	Set switch row S3 to choose whether the interrupt is to be initiated with a positive-going (leading) or negative-going (trailing) edge. The setting of a pair of switches applies to an entire byte.

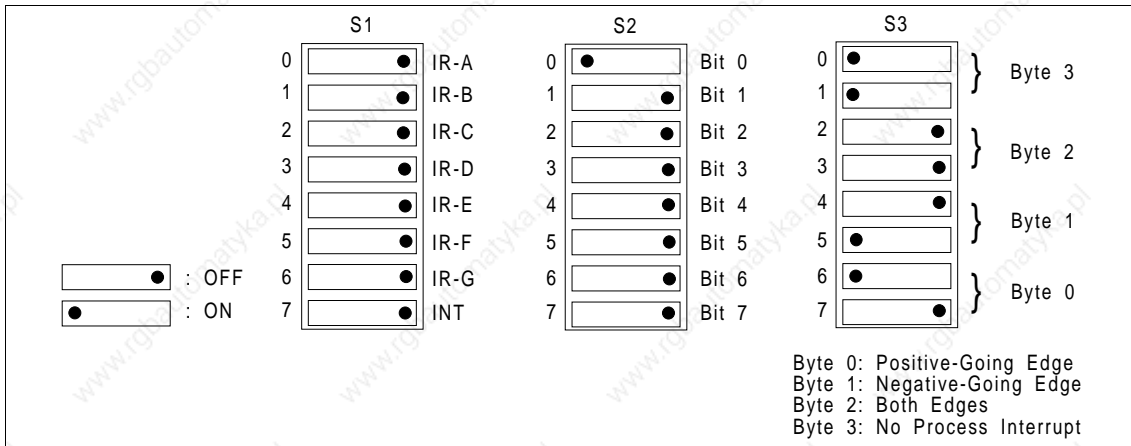

Figure 8-5 Switch Settings for Operation with Process Alarm via IB 0 (Example)

*Using two or more 432 digital input modules with process alarm via IB 0*

You can use up to eight 432 digital input modules with process alarm via IB 0 in one PLC. The modules must all be inserted in the CC or in the same EU for error-free acknowledgement of address 0. Each module reserves one bit in IB 0. You must set one module to bit 0 on switch row S2; on the other modules you must remove jumper X3 and set one of the other bits 2 to 8.

The module you have set to bit 0 is known as the master, and the other modules are slaves. On the master module, you must additionally set the number of slave modules on switch row S2. Refer to the labelling on the module cover.

*Using the 432 digital input module with other alarm-generating modules*

You can also use the 432 digital input module with process alarm together with other alarm-generating modules.

To operate the module with process alarm via interrupt, you must observe the following:

- If a process alarm is generated via an interrupt, the I/O words of all 432 digital input modules involved in this process alarm must be read in the alarm-processing OB; with IPs, the process alarms must be acknowledged (refer to the manuals of the IPs).
- The modules must be inserted at interrupt-capable slots (see Chapter 4).

To operate the module with process alarm via IB 0, you must observe the following:

- You may use up to eight alarm-generating modules.
- The modules must all be inserted in the CC or all in the same EU.
- You must operate the 432 module as the master. If you use two or more 432 digital input modules with other alarm-generating modules, you must operate one 432 as the master and all others as slaves.

#### 8.1.4

#### Special Features of the DI/DQ 482

The DI/DQ 482 digital input/output module is an I/O module which allows the processing of process signals in conjunction with the IP 257, with the S5-135U/155U PLC and the EU 185U (see the IP 257 manual). Described in the following is the operation of the DI/DQ 482 without IP 257.

The DI/DQ 482 has 32 channels which are **jointly** isolated, i.e. there is **no** subdivision into groups in the module. Channels 0.0 to 0.7 are digital outputs, Channels 2.0 to 3.7 are digital inputs; Channels 1.0 to 1.7 can be optionally and individually operated as inputs or outputs.

#### Changeover of the I/O byte

The operation of Channels 1.0 to 1.7 as inputs or outputs merely depends on the user program. You define the byte as an input with a read access to the DI/DQ; you define the byte as an output with a write access. The double-function of the byte also allows the output byte to be read out.

Unused channels should not be wired nor addressed by program. When these channels are used as inputs, it should be noted that the corresponding bits in the output register remain at logic 0. This resetting of output registers is executed automatically after power-up of the PLC or EU.

#### Note

When at least one of Channels 1.0 to 1.7 is operated as an input, the connected sensors and the 1L+ terminal must have the same power supply. If this is not the case, the input voltage acts on the 1L+ terminal. The resultant supply to the output amplifiers of Channels 0.0 to 1.7 causes currents to be drawn via the wired input terminal; these currents may assume different values, depending on the control states of the outputs.

With the DI/DQ 482, you must set slide switch S2 to setting 1 for operation without the IP 257.

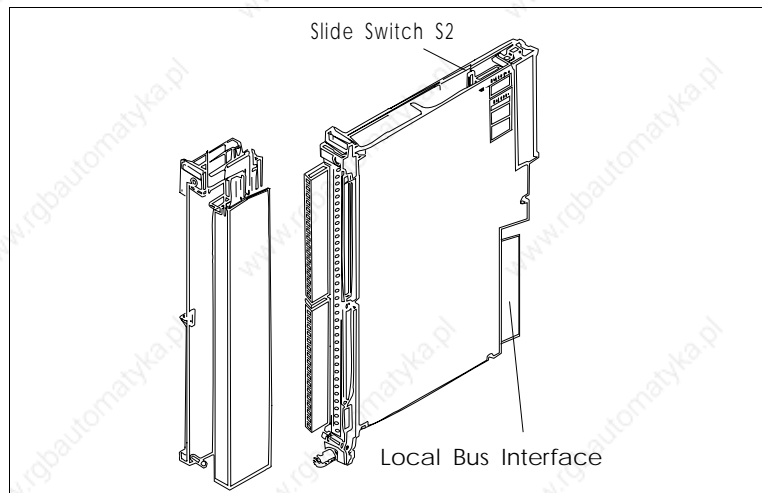

Figure 8-6 Slide Switch S2 on the DI/DQ 482



## 8.2 Installation and Startup

This section describes how to prepare digital input/output modules for installation, and how to install and wire them.

### 8.2.1

#### Setting the Module Address

You set the module address on the addressing switch. This also establishes the necessary assignments between user program and process connection.

The address of the digital input modules (input bytes IB 0 to 255 or 252 for the DI/DQ 482) and digital output modules (output bytes QB 0 to 255 or 252 for the DI/DQ 482) is the sum of the binary significances established by depressing the individual rockers in the On setting (●).

The modules are addressed by the STEP 5 program under their parameters (byte address).

#### Labelling field

You can affix the adhesive label with the desired module address on a labelling field under the addressing switch. Suitable labels are supplied with the CC.

The switch rockers with which the module address (IB n or QB n) is specified as a decimal number, are marked by dots on the label.

Do not use a pencil to set the addressing switch.

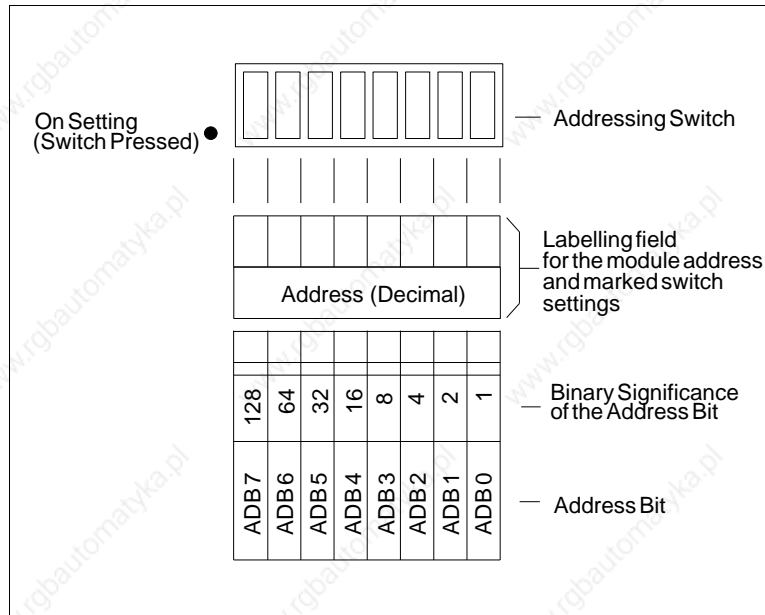

Figure 8-7 Labelling of the Addressing Switch  
(Extract from Module Labelling)

The address byte under which the module is referenced by the STEP 5 program is independent of the slot.

**Start address**

For modules with 16 or 32 inputs or outputs, i.e. 2 or 4 bytes, only the lowest address (start address) is set for the first byte. The addresses of the following bytes of the same module are decoded on the module.

If, for example, the address 20 is set for a 16-bit module (2 bytes), the following address 21 is decoded internally and is no longer available. The next free address would be 22.

For a 32-bit module (4 bytes) with start address 20, addresses 21, 22 and 23 would be decoded internally. The next free address would be 24.

Addresses already assigned must not be set again.

However, digital input and output modules may be given the same address because they are referenced by different commands in the user program.

**Example**

Digital input module with 8 inputs (IB 23) or digital output module with 8 outputs (QB 23).

The address is the sum of binary significances set with the individual coding switches:

$$23 = 1 + 2 + 4 + 16 = 2^0 + 2^1 + 2^2 + 2^4$$

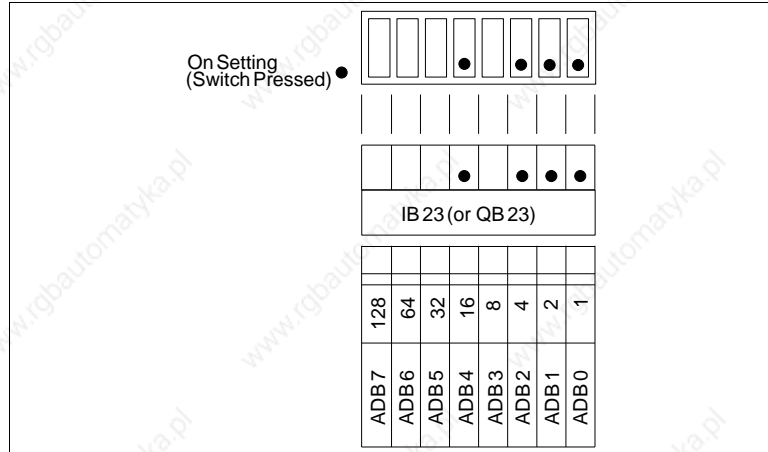

**Example**

Digital input module with 32 inputs (IB 80) or digital output module with 32 outputs (QB 80).

The address is the sum of binary significances set with the individual coding switches:

$$80 = 16 + 64 = 2^4 + 2^6$$

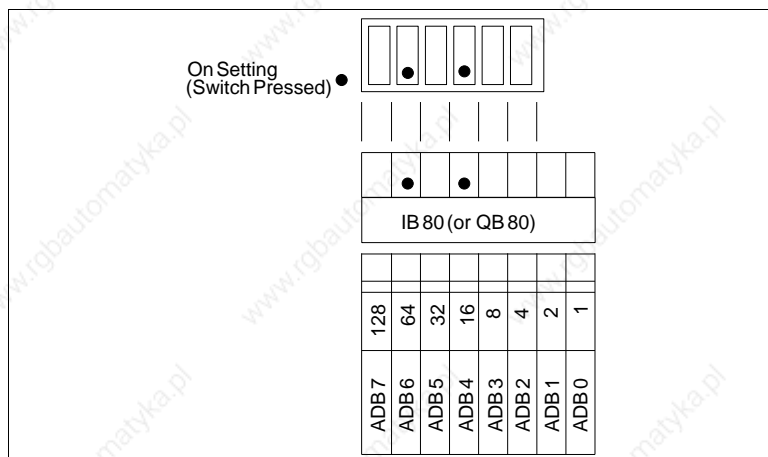

The following table is an overview of settings for addressing digital input/output modules.

Significance Byte Address

Significance	Byte Address															
	1	2	4	8												
128																
64																
32																
16																
	0	1	2	3	4	5	6	7	8	9	10	11	12	13	14	15
	16	17	18	19	20	21	22	23	24	25	26	27	28	29	30	31
	32	33	34	35	36	37	38	39	40	41	42	43	44	45	46	47
	48	49	50	51	52	53	54	55	56	57	58	59	60	61	62	63
	64	65	66	67	68	69	70	71	72	73	74	75	76	77	78	79
	80	81	82	83	84	85	86	87	88	89	90	91	92	93	94	95
	96	97	98	99	100	101	102	103	104	105	106	107	108	109	110	111
	112	113	114	115	116	117	118	119	120	121	122	123	124	125	126	127
	128	129	130	131	132	133	134	135	136	137	138	139	140	141	142	143
	144	145	146	147	148	149	150	151	152	153	154	155	156	157	158	159
	160	161	162	163	164	165	166	167	168	169	170	171	172	173	174	175
	176	177	178	179	180	181	182	183	184	185	186	187	188	189	190	191
	192	193	194	195	196	197	198	199	200	201	202	203	204	205	206	207
	208	209	210	211	212	213	214	215	216	217	218	219	220	221	222	223
	224	225	226	227	228	229	230	231	232	233	234	235	236	237	238	239
	240	241	242	243	244	245	246	247	248	249	250	251	252	253	254	255
8 Channels	x	x	x	x	x	x	x	x	x	x	x	x	x	x	x	x
16 Channels	x		x		x		x		x		x		x		x	
32 Channels	x				x				x				x			

1) Address range for digital input and digital output modules whose signals are not routed via the process image.

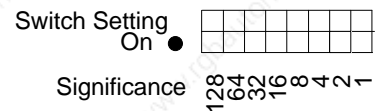

## 8.2.2 Removing and Inserting Modules



### Warning

When removing and inserting the front connector during operation, hazardous voltages of more than 25 V AC or 60 V DC may be present at the module pins. When this is the case at the front connector, live modules may only be replaced by electrical specialists or trained personnel in such a way that the module pins are not touched.

During operation, the front connector and module must not be removed or inserted without the enable jumper or active enable circuit.

Install a digital input/output module as follows:

Step	Action
1	Release the upper locking bar on the subrack and swivel it upwards and out.
2	Insert the module at the desired slot in the subrack and push it back in the guides.
3	Latch the module by rotating the locking pin by 90° at the lower end of the module.
4	Engage the front connector on the support pin of the module and swivel it up. The width of the support pin also provides keying to prevent front connectors from being fitted to the wrong modules (e.g. 230 V AC front connector on 24 V DC modules).
5	Tighten the screw in the upper part of the front connector.

Remove a digital input/output module as follows:

Step	Action
1	Release the upper locking bar on the subrack and swivel it upwards and out.
2	Slacken the screw in the upper part of the front connector. This causes the front connector to be pressed out of the female connector of the module. Contacts F+ and F- of the enable input at the upper end of the front connector are thus opened first.
3	Swing the front connector out and lift it away from the support pin of the module.
4	Release the module, if necessary, by rotating the locking pin by 90°. You can pull the module out of the subrack with a grip which swivels outwards.

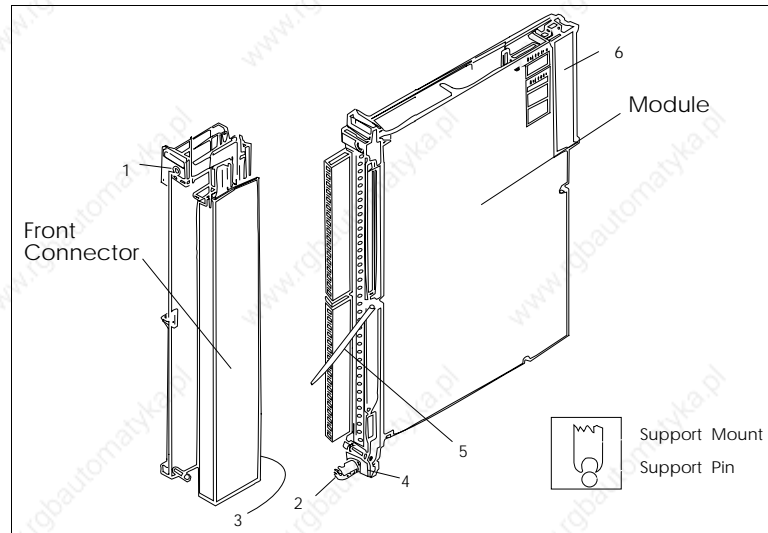

Figure 8-8 Module with Front Connector

- 1 Screw
- 2 Locking pin
- 3 Support mount
- 4 Support pin
- 5 Grip
- 6 Backplane connector

### Wiring

Comply with VDE Specifications 0100 and 0160 to carry out the wiring of the supply and signal lines which are to be connected to the programmable controllers and front connectors of the modules. Detailed information on the supply of power, cabinet assembly, cabinet ventilation, cabinet wiring and protective measures can be found in Chapter 3.

### 8.2.3 Marking of Modules

For the marking of modules and front connectors, a set of labels is supplied with the modules for the labelling, and a set of labels with the addresses is supplied with the central controller. Figure 8-9 shows the locations of the labels. The self-adhesive address label is pre-printed. You can mark the strips to identify the signal line terminals.

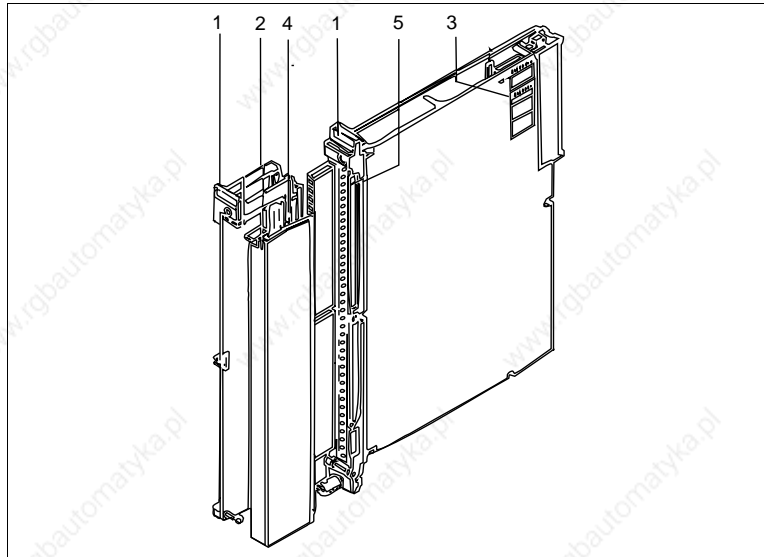

Figure 8-9 Marking and Labelling of Modules

- 1 Address label with the module address (output byte QB n or input byte IB n) under which the module is addressed by the STEP 5 program (address labels are supplied with the PLC), and for marking the addressing switch settings
- 2 Labelling strip with the product designation which is color-coded to distinguish between the various module types, as well as fields to mark the version and for user-related labelling of channels.  
Color codes:  

Digital inputs for DC voltage	blue
Digital inputs for AC voltage	red
Digital outputs for DC voltage	green
Digital outputs for AC voltage	orange

 Update the version when replacing modules!
- 3 Label with module address and marking of the required settings for the addressing switch
- 4 Labelling strip for terminal designations or connection diagrams for the front connector
- 5 Name plate

### 8.2.4

#### Connecting the Signal Lines

The modules have 20 or 42-way blade connectors with contact blades measuring 2.4 x 0.8 mm. Front connectors for 20 and 40 mm mounting width with crimp connection and 40 mm mounting width with screw connection are provided to connect the signal lines (screwdriver blade width: 3.5 mm, maximum torque: 0.8 Nm).

Use stranded conductor to facilitate handling of the front connector.

When the crimp contact is inserted in the plastic body of the front connector, a click can clearly be heard. This indicates that the contact is engaged. For jumpering or to correct the wiring, you can remove the contacts with a releasing tool (see ordering information) without having to pull out the front connector.

Ferrules are not required for screw connections, because the screw terminals are provided with wire protection. You can use ferrules of 7 mm in length to DIN 46228.

The maximum terminal area is 2 x 2.5 mm<sup>2</sup>.

Terminal Type	Connector Type 6ES5 497-	Max. No. of Contacts	Cross-Sec. of Signal or Supply Conductor	Connector for Rated Voltage	Front Connector Width	Module 6ES5-	
						For Operation With Fan	Without Fan
Crimp connection	4UA12	42	0.5 to 1.5 mm <sup>2</sup>	5 to 60 V DC	20 mm	420, 430, 431, 432, 434, 441, 451, 458	-
	4UA22	42	0.5 to 1.5 mm <sup>2</sup>	V5 to 60 V DC	40 mm	453, 454, 457	420, 430, 431, 432, 434, 441, 451, 453, 454, 457, 458
	4UA42	20	0.5 to 1.5 mm <sup>2</sup>	24 to 230 V AC	40 mm	435, 436, 455, 456	
Screw connection	4UB12 4UB32	42	0.5 to 2 x 2.5 mm <sup>2</sup>	5 to 60 V DC	40 mm 20 mm	420, 430, 431, 432, 434, 441, 451, 453, 454, 457, 458	
	4UB22	25	0.5 to 2 x 2.5 mm <sup>2</sup>	5 to 60 V DC	40 mm	454	
	4UB42	20	0.5 to 2 x 2.5 mm <sup>2</sup>	24 to 230 V AC	40 mm	435, 436, 455, 456	



#### Caution

Only extra-low voltage ≤ 60 V DC with safety separation from system voltage may be used for the 24 V DC supply and for the 24 V DC input signals. Safety separation can be implemented to the requirements of, amongst other sources, VDE 0100 Part 410/HD 384-4-41/IEC 364-4-41 (as functional extra-low voltage with safety separation) or VDE 0805/EN 60950/IEC 950 (as safety extra-low voltage SELV) or VDE 0106 Part 101.



**8.2.5  
Connection of Outputs in  
Parallel and Switching On  
the Load via a Contact**



**Caution**

The parallel connection of outputs to increase the load is not permissible.

*Digital output modules for  
DC voltage*

Outputs of modules with the same load voltage supply may be connected in parallel without additional circuitry.

An external diode must be fitted to the output lines of modules fed from different load voltage supplies (exception: 453, 457). In the case of different logic states of the two outputs, the maximum permissible output current corresponds to that of the lower stage.

The contact (e.g. for manual operation) is connected to one of the two L+.

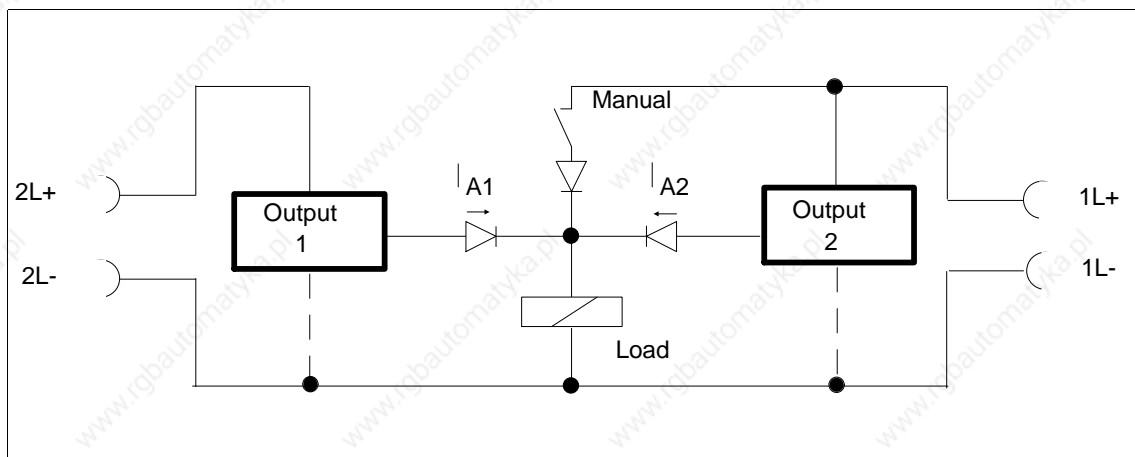

Figure 8-10 Parallel Connection of Outputs for DC Voltage Outputs

*Digital output modules for AC  
voltage*

Outputs can be connected in parallel without increasing the load if they are connected to the same phase (L) and the same neutral conductor (N).

The load must be at least 50 mA per output to keep to the permissible residual voltage at logic 0. The maximum switching current of 2 A per load must not be exceeded.

The load can also be switched via a contact.

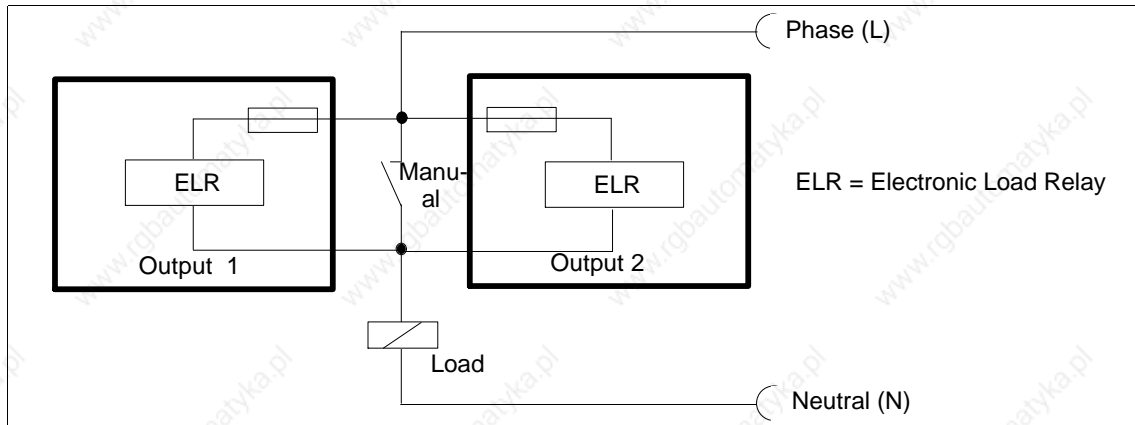

Figure 8-11 Parallel Connection of Outputs for AC Voltage Outputs

**Connection of input/output modules to two power supply units**

Given here are two examples of the feeding of inputs and outputs of different modules from two power supply units.

With non-floating input/output modules, the negative terminals (L-) of the power supply units are connected to reference potential (PE) because the inputs of the 420 module are referred to chassis ground.

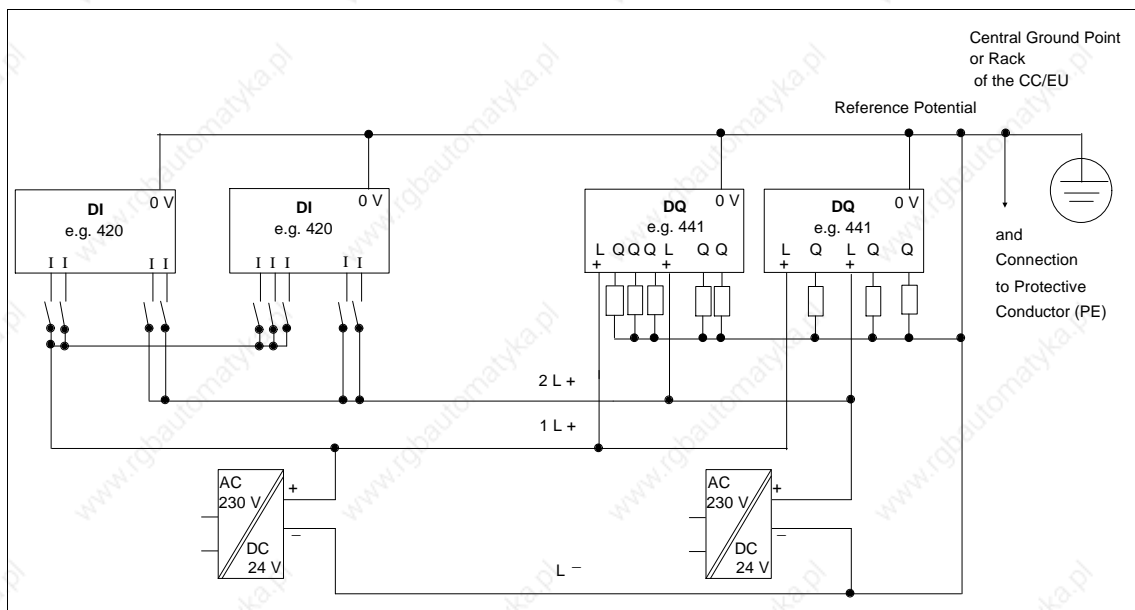

Figure 8-12 Feeding of Non-Floating Input/Output Modules from Two Power Supply Units

With isolated input/output modules the supply voltage is applied separately to the individual modules.

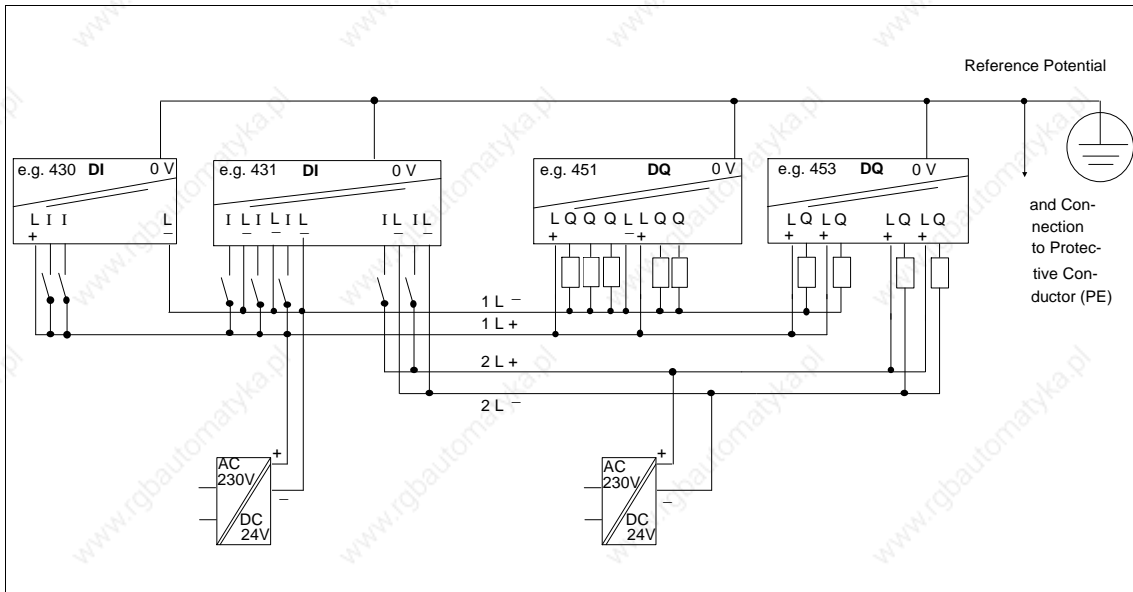

Figure 8-13 Feeding of Isolated Input/Output Modules from Two Power Supply Units

With isolated modules, the inputs or outputs can be fed from two separate power supply units in isolation groups created by the internal distribution in the module.

Note that when inputs or outputs from two isolated groups are connected to one power supply unit, isolation between the groups is defeated.

**8.2.6 Short-Circuit Protection and Fusing**

With digital output modules for DC voltage, fuses are provided on the module, in addition to the electronic short-circuit protection, for the wiring cables and to protect the module. The fuses also provide protection against reversal of supply voltage connections and can only be replaced at the factory.

The electronic short-circuit protection guaranteed in the technical specifications applies to a resistance which is lower than the specified, maximum permissible line resistance.

In the event of a short-circuit, two to three-times the rated output current flows briefly at the output before the switched electronic short-circuit protection becomes effective. When selecting the load power supply units, therefore, allow for the increased short-circuit current as well as all connected output loads (observe the coincidence factor). With unregulated load power supplies, this overcurrent is generally ensured. With regulated load power supplies, especially at low output power levels (up to 20 A), you must allow for a corresponding overcurrent.

### 8.2.7 Arc-Quenching for Inductive Loads

**Note**

Digital output modules have integrated circuits on the module to quench inductive loads (refer to the technical specifications of the output modules).

Exception: The 458 digital output module allows the switching of inductive loads with contact protection submodules.

The integrated circuits on the modules for quenching inductive loads are disabled if the load circuits are interrupted, either

- operationally by contacts and switches,
- or by fuses in the event of a fault.

This can result in excessive, inductive breaking voltages which put fault-free operation at risk.

You can prevent this with additional, external quenching circuitry for the inductive loads.

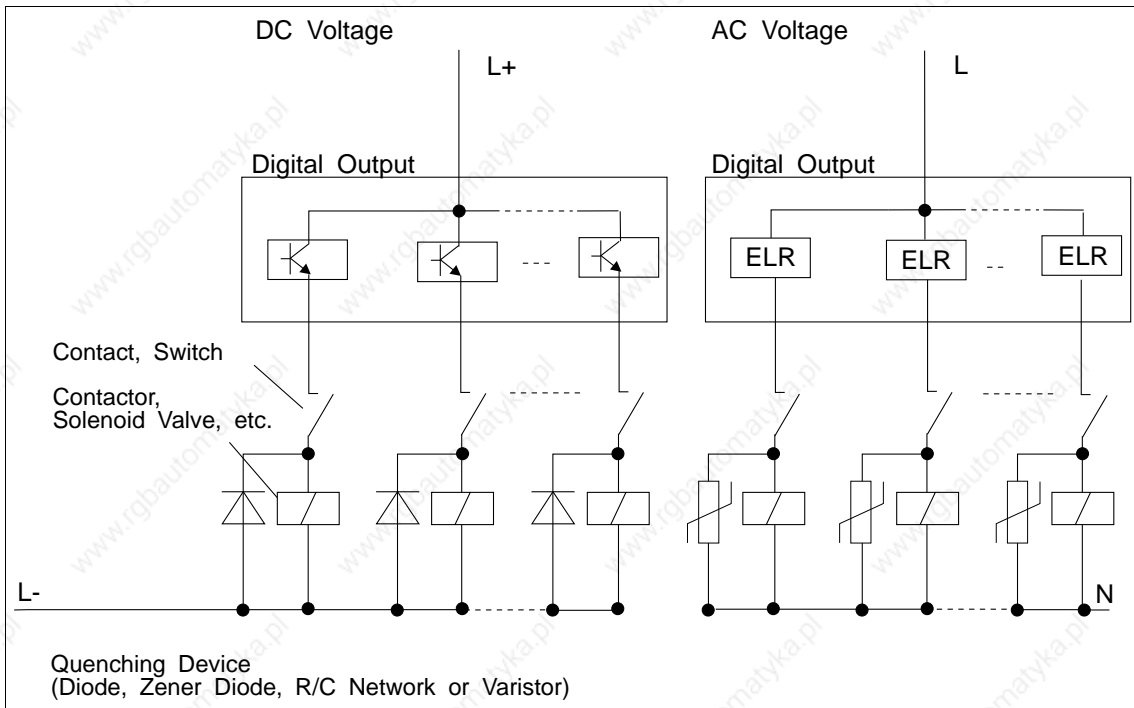

Figure 8-14 Quenching of Inductive Loads when the Load Circuit is Opened

*External quenching circuitry*

External quenching circuitry is needed when

- the switching frequency of an output is greater than that specified in the technical specifications (thermal stress of the integrated circuit for quenching inductive loads);
- disconnection of output lines can be expected;
- disconnection of the supply line can be expected.

When selecting or designing the quenching circuitry, the technical specifications for the digital output should be taken into account. These are:

- The permissible overvoltage for the supply voltage (see Section 8.3 "Common Technical Specifications")
- Inductive breaking voltage of the output (see Section 8.4 "Description of Individual Modules")

*Switching frequency of the output is higher than the permissible value*

An external quenching circuit only provides thermal relief if its quenching voltage is lower than the breaking voltage specified for the module, allowing for unfavorable supply voltage conditions.

**Example:** 453 digital output

Inductive breaking voltage L+ - 47 V (tech. specifications)

Max. supply voltage L+ = 30 V

Quenching voltage referred to L- (0 V ground) is - 17 V

The quenching device must be rated at approximately 15 V and the switched load current, e.g. 1 A.

8

*Disconnecting the load circuit*

A quenching device rated for the induced breaking current must be provided at the load (see Figure 8-14).

The quenching voltage at the load is independent of the module. The quenching devices must also ensure that the overvoltages at the switch and in the wiring do not exceed the disturbance voltage and voltage hazard limits permissible to VDE/IEC.

*Disconnecting the supply line L+ and L*

**The following applies to digital outputs for DC voltage:**

In general, load power supplies should be switched on the primary side to utilize the low-resistance secondary winding and smoothing capacitors of the power supply for energy compensation in the dropping of inductive loads. The load power supply switch should only be considered as a circuit breaker.

*Switched-through outputs*

With switched-through digital outputs and disconnection of the supply line L+, the output current is maintained during the quenching time by capacitors and the reverse voltage protection diode on the module. This severe electrical stress of the module should be avoided during operations, because it can result in a fault in the long term.

Two-wire switches

**With two-wire switches and AC voltage outputs:**

Disconnection of the supply voltage during operation is not permissible without additional protective circuitry. Quenching of the inductive load is achieved here via the load power supply unit or system. Since, as two-wire switches, the outputs have no L-/N (0 V ground) terminal, the inductive load cannot be quenched on the module when the supply line is disconnected.

With the 453 and 457 modules using two-wire switches, the overvoltages can result in destruction of the module.

If the load voltage must be switched for safety reasons, you must provide external quenching circuitry at each inductive load (see Figure 8-15).

Instead, with the 453 and 457 modules using two-wire switches, you can insert a quenching device (diode) with adequate ratings after contact K from the L+ line to L-.

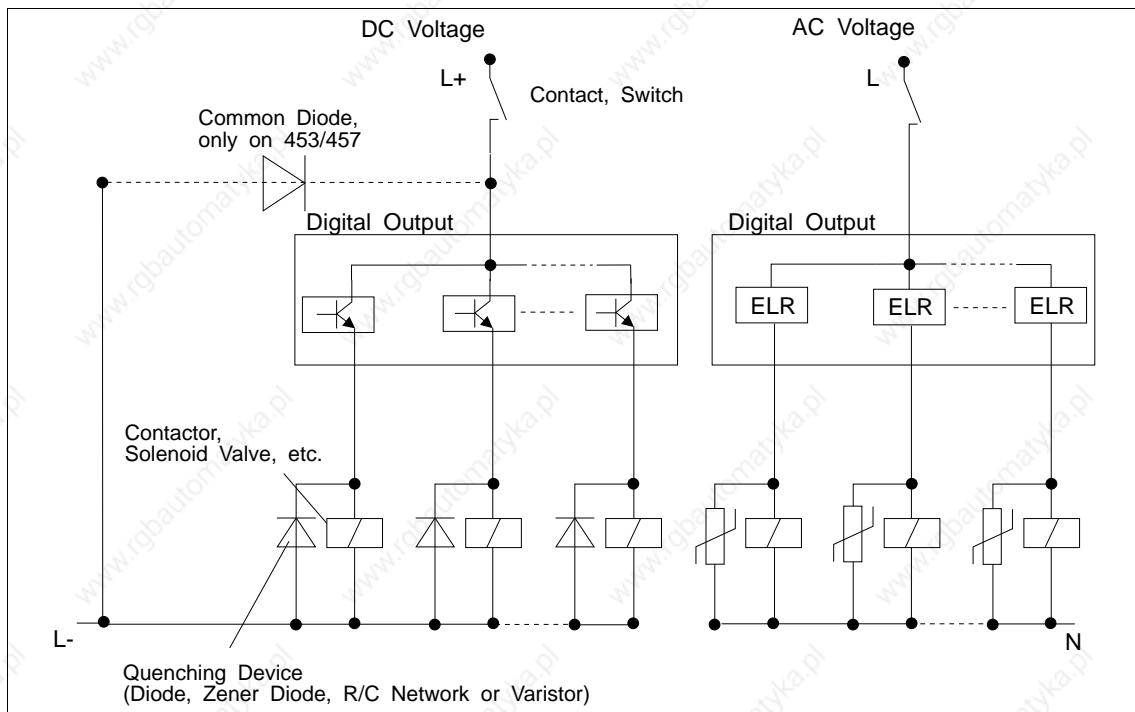

Figure 8-15 Quenching of Inductive Loads when Switching the Supply Line L+ and L.

### 8.3 Common Technical Specifications

#### Important for the USA and Canada

The following approvals have been obtained for all the modules listed in this chapter:



UL Listing Mark  
Underwriters Laboratories (UL) to  
Standard UL 508, Report E85972



CSA Certification Mark  
Canadian Standard Association (CSA) to Standard  
C 22.2 No. 142, Report LR 63533

Valid safety specifications	VDE 0160
Class of protection	I
Type of protection	IP 20 to IEC 529/DIN 40050 when empty slots are covered by dummy front plates
<b>Climatic ambient conditions</b>	
Operation in equipment with fan	0 to 50 °C
Operation in equipment without fan (module clearance: 40 mm)	0 to 55 °C Supply air measured at lower inlet of power supply; for a cabinet assembly, note that the removable power dissipation depends on the cabinet design, its ambient temperature and arrangement of equipment.
Transportation and storage temperature-	- 40 to 70 °C
Temperature variation in operation transportation and storage	10 K/h max. 20 K/h max. (When delivered under 0 °C, allow 3 h min. settling time on account of possible condensation)
Relative humidity in operation transportation and storage	95 % max. at 25 °C, no condensation 95 % max. at 25 °C, no condensation
Site altitude in operation transportation and storage	- 1000 m to + 1500 m - 1000 m to + 3500 m
Pollutants SO <sub>2</sub> H <sub>2</sub> S	0.5 ppm max. (rel. humidity under 60 %) 0.1 ppm max. (rel. humidity under 60 %)
<b>Mechanical ambient conditions</b>	
Vibration in operation	10 to 58 Hz (const. amplitude 0.15 mm) 58 to 500 Hz (const. acceleration 2 g)
Mechanical requirements	Installation in stationary equipment which is not free from vibrations; installation on ships and vehicles, allowing for special installation specifications, but not on the engine.

## Common Technical Specifications

<b>Operand identifiers</b>	
for inputs	I = Input
for outputs	Q = Output
Parameters	0.0 to 255.7
<b>Terminals</b>	
Rated DC voltage of module	L+
Reference potential for DC voltage	L-
Rated AC voltage of module	L
Reference potential for AC voltage	N
Permissible line length for digital output modules	Allow for the line resistance and tolerance of the supply voltage for the relevant output current.
Enable inputs	F+ F- (Enable voltage according to the rated voltage of the module)
Short-circuit signalling output (only when the short-circuited output is at logic 1)	H+ (Supply for 1L+, referred to L- of the module)
Max. permissible supply voltage for rated voltage 24 V DC (L+/L-) <sup>1)</sup> for rated voltage 60 V DC (L+/L-) <sup>1)</sup> for rated voltage 115 V/230 V AC (L/N)	36 V DC for 100 ms 90 V DC for 100 ms 276 V AC for 100 ms
Supply voltage ripple $V_{pp}$ referred to rated DC voltage	15 % max. <sup>2)</sup>
Interference suppression at digital inputs	$\leq 1.5 \text{ ms}$ <sup>3)</sup>
Interference pulse length at digital outputs	$\leq 1.5 \text{ ms}$ <sup>3) 4)</sup>
Circuitry for inductive loads:	Protective devices to limit the breaking voltage are provided on the digital output modules. Additional protective circuitry for the load is only required in exceptional cases. <b>Exception:</b> 458 digital output module
Switching of capacitive loads:	50 nF max. at full load
<b>Safety tests</b>	
Surge voltage test to IEC 255-4	DC: Input/output to L-: $V_p = 1 \text{ kV}$ , 1.2/50 $\mu\text{s}$ AC: Input/output to L-: $V_p = 2.5 \text{ kV}$ , 1.2/50 $\mu\text{s}$
RFI test to IEC 255-4	DC: Input/output to L-: $V_p = 1 \text{ kV}$ , 1 MHz AC: Input/output to L-: $V_p = 2.5 \text{ kV}$ , 1 MHz
<b>Safety test</b> for the -4UA13 modules	+
Immunity from conducted interference on signal line	1 kV to IEC 801-4 (burst)
Immunity from discharge of static electricity	8 kV discharge in air to IEC 801-2

- 1) Supply and signal voltages must be produced as functional voltage with safety separation.
- 2) The supply voltage range values are limit values. They include ripple.
- 3) If not otherwise specified
- 4) Must be bridged by the signal receiver



## 8.4 Specification Sheets for the Modules

The common technical specifications are given in Section 8.3.

### 8.4.1

#### 6ES5 420-4UA13 Digital Input Module

Rated input voltage	24 V DC
Number of inputs	32
Isolation	no
Input voltage for logic 0 for logic 1	- 33 to 5 V 13 to 33 V
Rated input current	8.5 mA
Input frequency	100 Hz max.
Delay time	3 ms typical (1.4 to 5 ms)
Input resistance	2.8 kilohms typical
Coincidence factor (total load capability)	100 %
Permissible line length	600 m max. unshielded 1000 m max. shielded
<b>Power supply</b>	
Digital section from system bus	5 V, 80 mA typical
Supply voltage for 2-wire BERO	22 to 33 V
Power dissipation (rated operation)	7.0 W
<b>Enable input (F+/F-)</b>	
Rated input voltage	24 V DC
Input voltage for logic 0 for logic 1	- 33 to 5 V 13 to 33 V
Rated input current	5 mA
Permissible linelength	200 m max.
Voltage test to VDE 0160	Between group and ground point: 1250 V AC
<b>Mechanical specifications</b>	
Dimensions (W x H x D)	20 mm x 255 mm x 195 mm
Weight	Approx. 0.4 kg

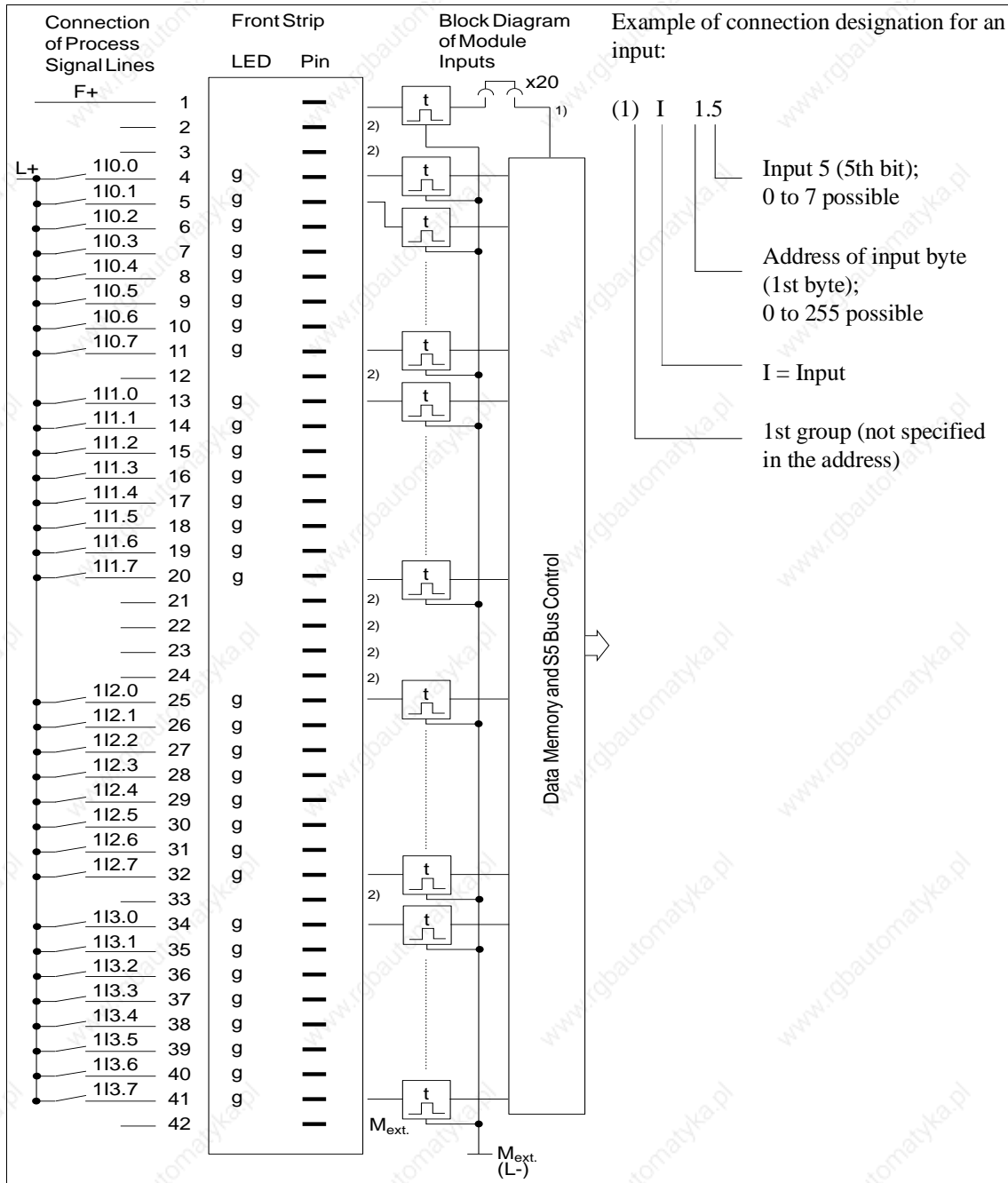

g = Green LED (status indicator)

F+ = Enable input

Connect L- of the power supply unit to the reference potential (PE).

- 1) Changeover of enable mode with jumper X20:  
Jumper inserted = Enable input active (factory setting)  
Jumper open = Enable input inactive.
- 2) The terminal is not connected internally. Even when this terminal is connected to input voltages, the clearances in air and leakage paths remain adequate to UL, CSA and VDE.

### 8.4.2 6ES5 430-4UA13 Digital Input Module

Rated input voltage	24 V DC
Number of inputs	32
Isolation	Yes, 1 group with 32 inputs
Input voltage for logic 0 for logic 1 <sup>1)</sup>	- 3 to 7 V 13 to 33 V
Rated input current	7.0 mA
Input frequency	100 Hz max.
Delay time	4 ms typical (2.5 to 6.5 ms)
Input resistance	3.3 kilohms typical
Coincidence factor (total load capability)	100 %
Permissible line length	600 m max. unshielded 1000 max. shielded
<b>Power supply</b>	
Digital section from system bus	5 V, 100 mA typical
Supply voltage for 2-wire BERO	22 to 33 V
Supply voltage L+/L-	24 V (20 to 30 V)
Current consumption from L+/L-	Approx. 100 mA
Power dissipation (rated operation)	8.3 W
<b>Enable input (F+/F-)</b>	
Rated input voltage	24 V DC
Input voltage for logic 0 for logic 1	- 33 to 5 V 13 to 33 V
Rated input current	5 mA
Permissible line length	200 m max.
Voltage test to VDE 0160	Between group and ground point: 1250 V AC
<b>Mechanical specifications</b>	
Dimensions (W x H x D)	20 mm x 255 mm x 195 mm
Weight	Approx. 0.4 kg

1) Polarity reversal for up to 8 inputs per module is permissible.

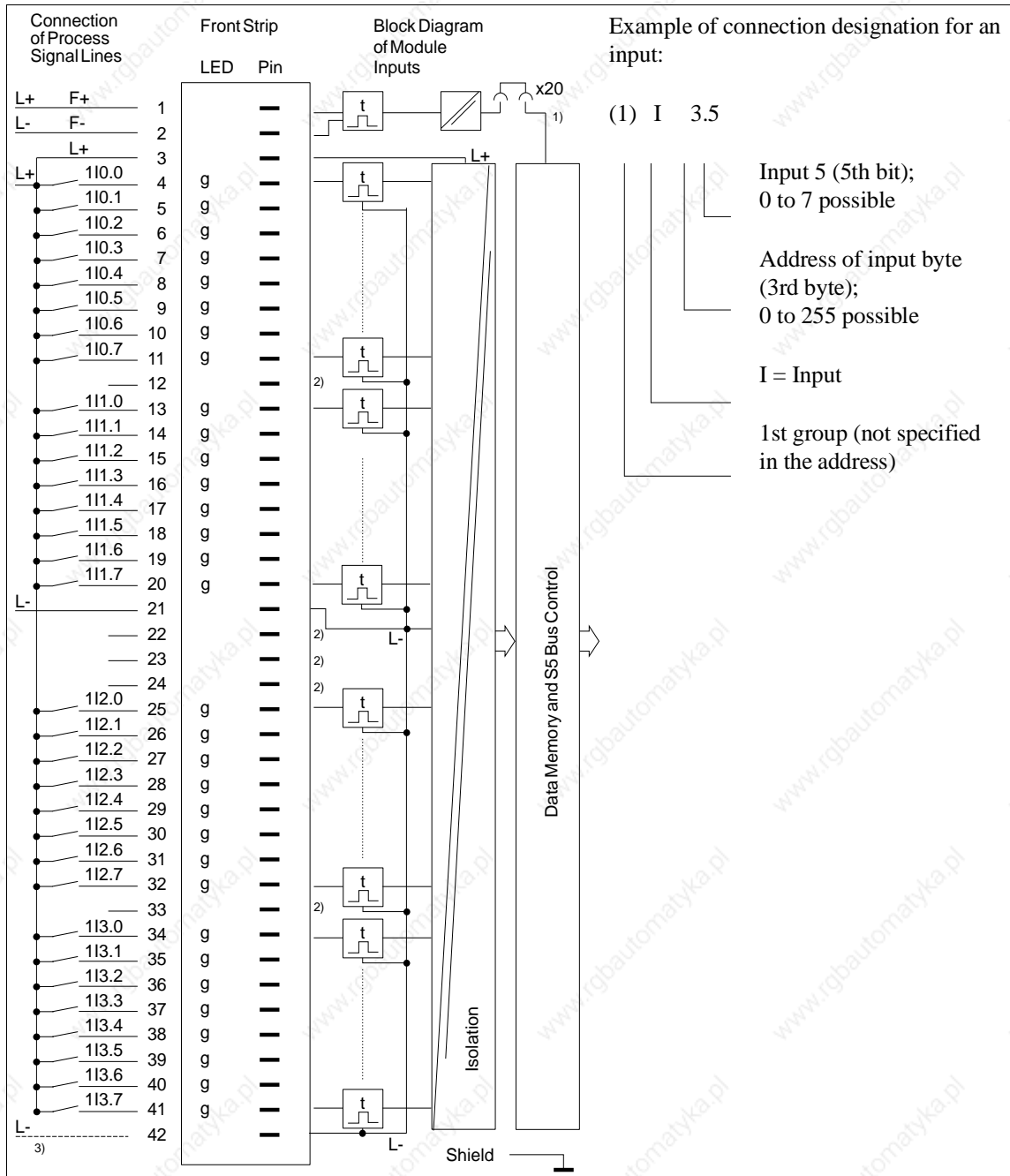

g = Green LED (status indicator)  
F+/F- = Enable input

- 1) Changeover of enable mode with jumper X20:  
Jumper inserted = Enable input active (factory setting)  
Jumper open = Enable input inactive.
- 2) The terminal is not connected internally. Even when this terminal is connected to input voltages, the clearances in air and leakage paths remain adequate to UL, CSA and VDE.
- 3) By connecting L- to pin 42, a leading and trailing connection to ground is established on the module when it is plugged in and removed.

### 8.4.3 6ES5 431-4UA12 Digital Input Module

Rated input voltage	24 to 60 V DC
Number of inputs	16
Isolation	Yes, 16 Inputs
Input voltage for logic 0 for logic 1	- 33 to 8 V 13 to 72 V
Rated input current	4.5 to 7.5 mA (24 to 60 V DC)
Input frequency	100 Hz max.
Delay time	3 ms typical (1.4 to 5 ms)
Coincidence factor (total load capability)	100 %
Permissible line length	400 m max. unshielded 1000 m max. shielded
<b>Power supply</b>	
Digital section from system bus	5 V, 90 mA typical
Supply voltage for 2-wire BERO	22 to 72 V
Power dissipation (rated operation)	2.2 to 7.7 W (24 to 60 V)
<b>Enable input (F+/F-)</b>	
Rated input voltage	24 to 60 V DC
Input voltage for logic 0 for logic 1	- 72 to 8 V 13 to 72 V
Rated input current	5 mA (at 48 V DC)
Permissible line length	200 m max.
Voltage test to VDE 0160	Between two groups: 1250 V AC Between group and ground point: 1250 V AC
<b>Mechanical specifications</b>	
Dimensions (W x H x D)	20 mm x 255 mm x 195 mm
Weight	Approx. 0.4 kg

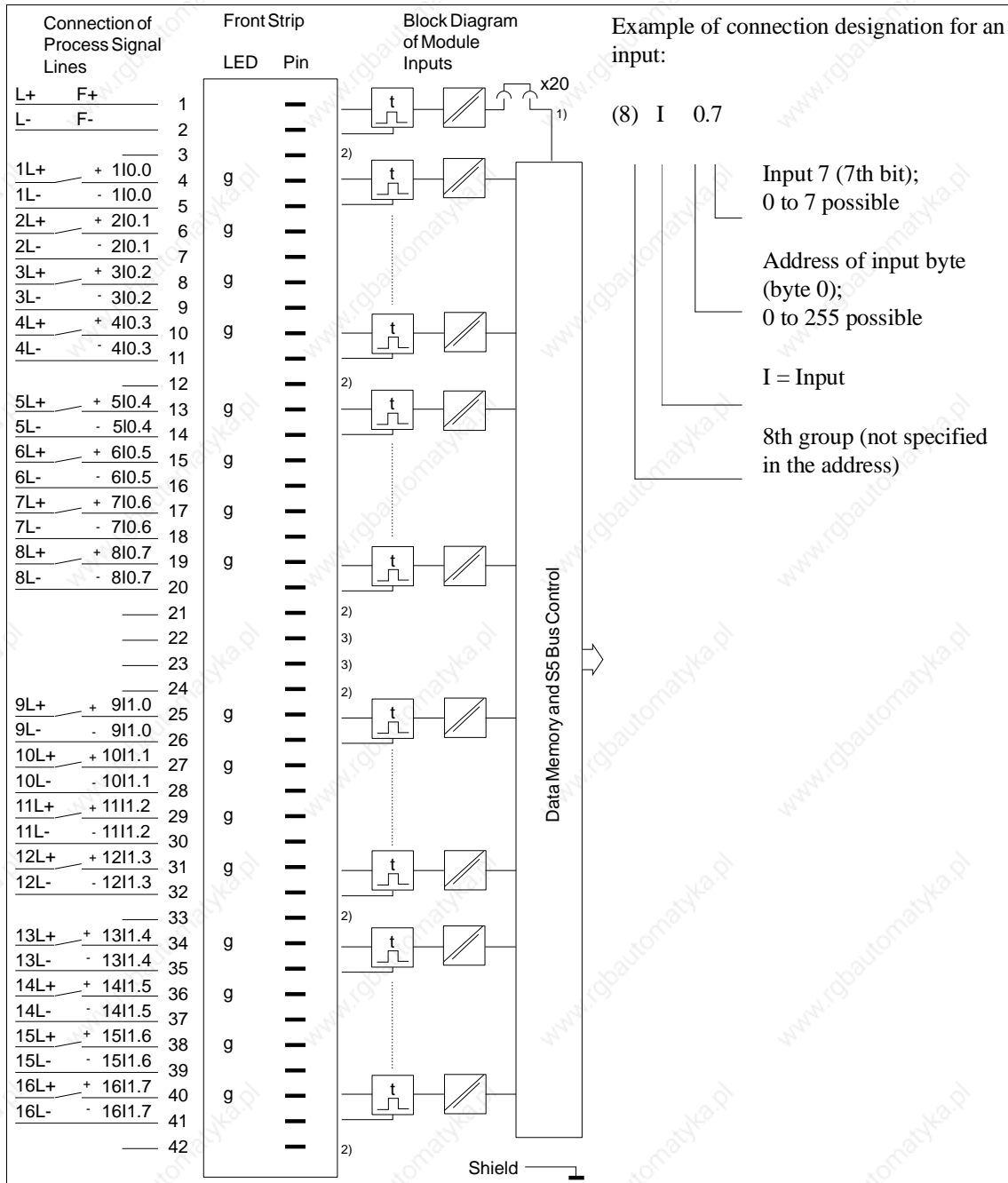

g = Green LED (status indicator)  
 F+/F- = Enable input

- 1) Changeover of enable mode with jumper X20:  
 Jumper inserted = Enable input active (factory setting)  
 Jumper open = Enable input inactive.
- 2) The terminal is not connected internally. When this terminal is connected to the input voltages, the clearances in air and leakage paths are no longer adequate to UL and CSA, but comply with VDE.
- 3) The terminal is not connected internally. When this terminal is connected to the input voltages, the clearances in the air and leakage paths remain adequate to UL, CSA and VDE.

#### 8.4.4 6ES5 432-4UA12 Digital Input Module

Rated input voltage	24 V DC
Number of inputs	32
Isolation	Yes, 4 groups of 8 inputs
Input voltage for logic 0 for logic 1	- 33 to 5 V 13 to 33 V
Rated input current	8.5 mA
Input frequency	100 Hz/300 Hz/1 kHz max.
Delay time <sup>1)</sup>	3 ms/1 ms/0.3 ms typical (1.5 to 4.8 ms/0.5 to 1.6 ms/0.15 to 0.48 ms)
Input resistance	2.8 kilohms typical
Coincidence factor (total load capability)	100 %
Permissible line length	600 m max. unshielded (3 ms) 200 m max. unshielded (1 ms) 50 m max. unshielded (0.3 ms)
<b>Power supply</b>	
Digital section from system bus	5 V, 200 mA typical
Supply voltage for 2-wire BERO	22 to 33 V
Power dissipation (rated operation)	7.5 W
<b>Enable input (F+/F-)</b>	
Rated input voltage	24 V DC
Input voltage for logic 0 for logic 1	- 33 to 5 V 13 to 33 V
Rated input current	5 mA
Permissible line length	200 m max.
Voltage test to VDE 0160	Between two groups: 1250 V AC Between group and ground point: 1250 V AC
<b>Mechanical specifications</b>	
Dimensions (W x H x D)	20 mm x 255 mm x 195 mm
Weight	Approx. 0.55 kg

1) Selectable in bytes with switch S5

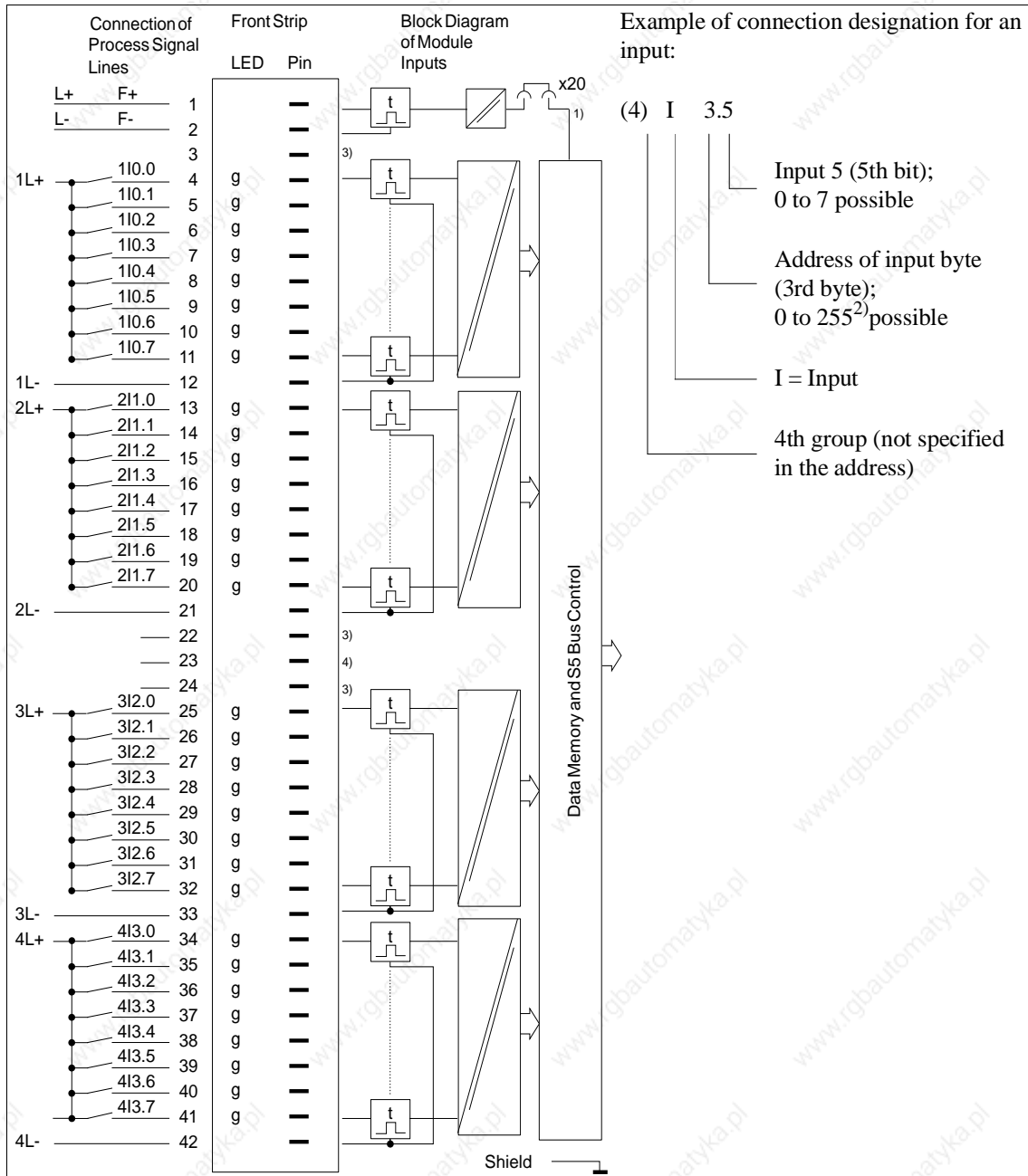

g = Green LED (status indicator)

F+/F- = Enable input

- 1) Changeover of enable mode with jumper X20:  
Jumper inserted = Enable input active (factory setting)  
Jumper open = Enable input inactive.
- 2) Only 128 to 255 permissible with group signal and interrupt.
- 3) The terminal is not connected internally. When this terminal is connected to the input voltages, the clearances in air and leakage paths are no longer adequate to UL and CSA, but comply with VDE.
- 4) The terminal is not connected internally. When this terminal is connected to the input voltages, the clearances in air and leakage paths remain adequate to UL, CSA and VDE.



**Labelling for module cover:**  
Mark the switch settings in the free fields.

X3	
Master (on)	
Slave (off)	

Byte	Delay Time			S5
	3 ms	1 ms	0.3 ms	
3	<input type="checkbox"/>	<input type="checkbox"/>	<input type="checkbox"/>	
	<input type="checkbox"/>	<input type="checkbox"/>	<input type="checkbox"/>	
2	<input type="checkbox"/>	<input type="checkbox"/>	<input type="checkbox"/>	
	<input type="checkbox"/>	<input type="checkbox"/>	<input type="checkbox"/>	
1	<input type="checkbox"/>	<input type="checkbox"/>	<input type="checkbox"/>	
	<input type="checkbox"/>	<input type="checkbox"/>	<input type="checkbox"/>	
0	<input type="checkbox"/>	<input type="checkbox"/>	<input type="checkbox"/>	
	<input type="checkbox"/>	<input type="checkbox"/>	<input type="checkbox"/>	

X4	
Group Signal	
active (on)	
inactive (off)	

Byte	Edge Trigger				S 3
3	<input type="checkbox"/>	<input type="checkbox"/>	<input type="checkbox"/>	<input type="checkbox"/>	
	<input type="checkbox"/>	<input type="checkbox"/>	<input type="checkbox"/>	<input type="checkbox"/>	
2	<input type="checkbox"/>	<input type="checkbox"/>	<input type="checkbox"/>	<input type="checkbox"/>	
	<input type="checkbox"/>	<input type="checkbox"/>	<input type="checkbox"/>	<input type="checkbox"/>	
1	<input type="checkbox"/>	<input type="checkbox"/>	<input type="checkbox"/>	<input type="checkbox"/>	
	<input type="checkbox"/>	<input type="checkbox"/>	<input type="checkbox"/>	<input type="checkbox"/>	
0	<input type="checkbox"/>	<input type="checkbox"/>	<input type="checkbox"/>	<input type="checkbox"/>	
	<input type="checkbox"/>	<input type="checkbox"/>	<input type="checkbox"/>	<input type="checkbox"/>	

S 1	<b>Interrupt</b>
	IRA
	IRB
	IRC
	IRD
	IRE
	IRF
	IRG
INT	

8

Data bit	Group Signal														S 2	
	Master submodule (Jumper X 3 on)							Slave submodule (Jumper X 3 off)								
	without Slave	1 Slave	2 Slave	3 Slave	4 Slave	5 Slave	6 Slave	7 Slave	1.Slave 0.1	2.Slave 0.2	3.Slave 0.3	4.Slave 0.4	5.Slave 0.5	6.Slave 0.6		7.Slave 0.7
0	<input type="checkbox"/>	<input type="checkbox"/>	<input type="checkbox"/>	<input type="checkbox"/>	<input type="checkbox"/>	<input type="checkbox"/>	<input type="checkbox"/>	<input type="checkbox"/>	<input type="checkbox"/>	<input type="checkbox"/>	<input type="checkbox"/>	<input type="checkbox"/>	<input type="checkbox"/>	<input type="checkbox"/>	<input type="checkbox"/>	
1	<input type="checkbox"/>	<input type="checkbox"/>	<input type="checkbox"/>	<input type="checkbox"/>	<input type="checkbox"/>	<input type="checkbox"/>	<input type="checkbox"/>	<input type="checkbox"/>	<input type="checkbox"/>	<input type="checkbox"/>	<input type="checkbox"/>	<input type="checkbox"/>	<input type="checkbox"/>	<input type="checkbox"/>	<input type="checkbox"/>	
2	<input type="checkbox"/>	<input type="checkbox"/>	<input type="checkbox"/>	<input type="checkbox"/>	<input type="checkbox"/>	<input type="checkbox"/>	<input type="checkbox"/>	<input type="checkbox"/>	<input type="checkbox"/>	<input type="checkbox"/>	<input type="checkbox"/>	<input type="checkbox"/>	<input type="checkbox"/>	<input type="checkbox"/>	<input type="checkbox"/>	
3	<input type="checkbox"/>	<input type="checkbox"/>	<input type="checkbox"/>	<input type="checkbox"/>	<input type="checkbox"/>	<input type="checkbox"/>	<input type="checkbox"/>	<input type="checkbox"/>	<input type="checkbox"/>	<input type="checkbox"/>	<input type="checkbox"/>	<input type="checkbox"/>	<input type="checkbox"/>	<input type="checkbox"/>	<input type="checkbox"/>	
4	<input type="checkbox"/>	<input type="checkbox"/>	<input type="checkbox"/>	<input type="checkbox"/>	<input type="checkbox"/>	<input type="checkbox"/>	<input type="checkbox"/>	<input type="checkbox"/>	<input type="checkbox"/>	<input type="checkbox"/>	<input type="checkbox"/>	<input type="checkbox"/>	<input type="checkbox"/>	<input type="checkbox"/>	<input type="checkbox"/>	
5	<input type="checkbox"/>	<input type="checkbox"/>	<input type="checkbox"/>	<input type="checkbox"/>	<input type="checkbox"/>	<input type="checkbox"/>	<input type="checkbox"/>	<input type="checkbox"/>	<input type="checkbox"/>	<input type="checkbox"/>	<input type="checkbox"/>	<input type="checkbox"/>	<input type="checkbox"/>	<input type="checkbox"/>	<input type="checkbox"/>	
6	<input type="checkbox"/>	<input type="checkbox"/>	<input type="checkbox"/>	<input type="checkbox"/>	<input type="checkbox"/>	<input type="checkbox"/>	<input type="checkbox"/>	<input type="checkbox"/>	<input type="checkbox"/>	<input type="checkbox"/>	<input type="checkbox"/>	<input type="checkbox"/>	<input type="checkbox"/>	<input type="checkbox"/>	<input type="checkbox"/>	
7	<input type="checkbox"/>	<input type="checkbox"/>	<input type="checkbox"/>	<input type="checkbox"/>	<input type="checkbox"/>	<input type="checkbox"/>	<input type="checkbox"/>	<input type="checkbox"/>	<input type="checkbox"/>	<input type="checkbox"/>	<input type="checkbox"/>	<input type="checkbox"/>	<input type="checkbox"/>	<input type="checkbox"/>	<input type="checkbox"/>	

**8.4.5**  
**6ES5 434-4UA12 Digital**  
**Input Module**

Rated input voltage (LH+)	5 to 15 V DC	
Rated input voltage (L+)	12 to 24 V DC (NAMUR) <sup>1)</sup>	
Number of inputs	32	
Isolation	Yes, 1 group of 32 inputs	
Input voltage	TTL: for logic 0 for logic 1 CMOS: for logic 0 for logic 1	0 to 0.8 V 2.4 to 5.0 V 0 V to 0.3 x LH+ 0.7 V x LH+ to 1 x LH+
Rated input current	TTL: for logic 0 for logic 1 CMOS: for logic 0 for logic 1 NAMUR: for logic 0 for logic 1	- 1 mA 0.1 mA or open input - 1 to - 3 mA (5 to 15 V) 0.1 to 0.3 mA (5 to 15 V) ≤ 1.2 mA ≥ 2.1 mA
Internal resistance	1 kilohm typical	
Line resistance	100 Hz max.	
Input frequency	max. 100 Hz	
Delay time	for positive-going edge for negative-going edge	3 ms typical (1.4 to 5 ms) 3 ms typical (1.4 to 5 ms)
Coincidence factor (total load capability)	100 %	
Permissible line length	TTL/CMOS NAMUR	200 m max. unshielded 600 m max. unshielded
<b>Power supply</b>		
Digital section from system bus	5 V, 80 mA typical	
Supply voltage L+/L-	24 V (20 to 30 V)	
Current consumption at L+/L-	100 mA each	
Current consumption at LH+/LH-	150 mA each at 15 V input voltage	
Current output from LH+/LH-	120 mA each at 8.5 V sensor supply (NAMUR) <sup>2)</sup>	
Power dissipation (rated operation)	5.5 W	
<b>Enable input (F+/F-)</b>		
Rated input voltage	5/15/24 V DC	
Input voltage	for logic 0 for logic 1	- 15 to 2 V 4 to 33 V
Rated input current	5 mA	
Permissible line length	100 m max.	
Voltage test to VDE 0160	Between group and ground point: 1250 V AC	
<b>Mechanical specifications</b>		
Dimensions (W x H x D)	20 mm x 255 mm x 195 mm	
Weight	Approx. 0.45 kg	

- 1) NAMUR = Sensor with current output to DIN 19234, Standards Committee for Measurements and Control. However, the module is not intrinsically safe.
- 2) The current consumption from L+/L- increases accordingly.

**Connection for supply voltage,  
jumpers and sensor supply in groups of 2 bytes  
(16 inputs each)**

Type of Sensor	Byte 0 + 1 Byte 2 + 3	1L+ Terminal 3 2L+ Terminal 24	1LH+ Terminal 12 2LH+ Terminal 33	1LH- Terminal 22 2LH- Terminal 23
NAMUR		Connect to L+(24 V supply)	Output for sensor supply	Jumper to L-Terminal 21
CMOS		open	Connect to 5 to 15 V supply	open
TTL		open	Connect to 5 V supply	open

The types of sensor can be arbitrarily mixed in groups of 16 inputs. With CMOS TTL sensors, open inputs are at logic 1 (LED is lit).

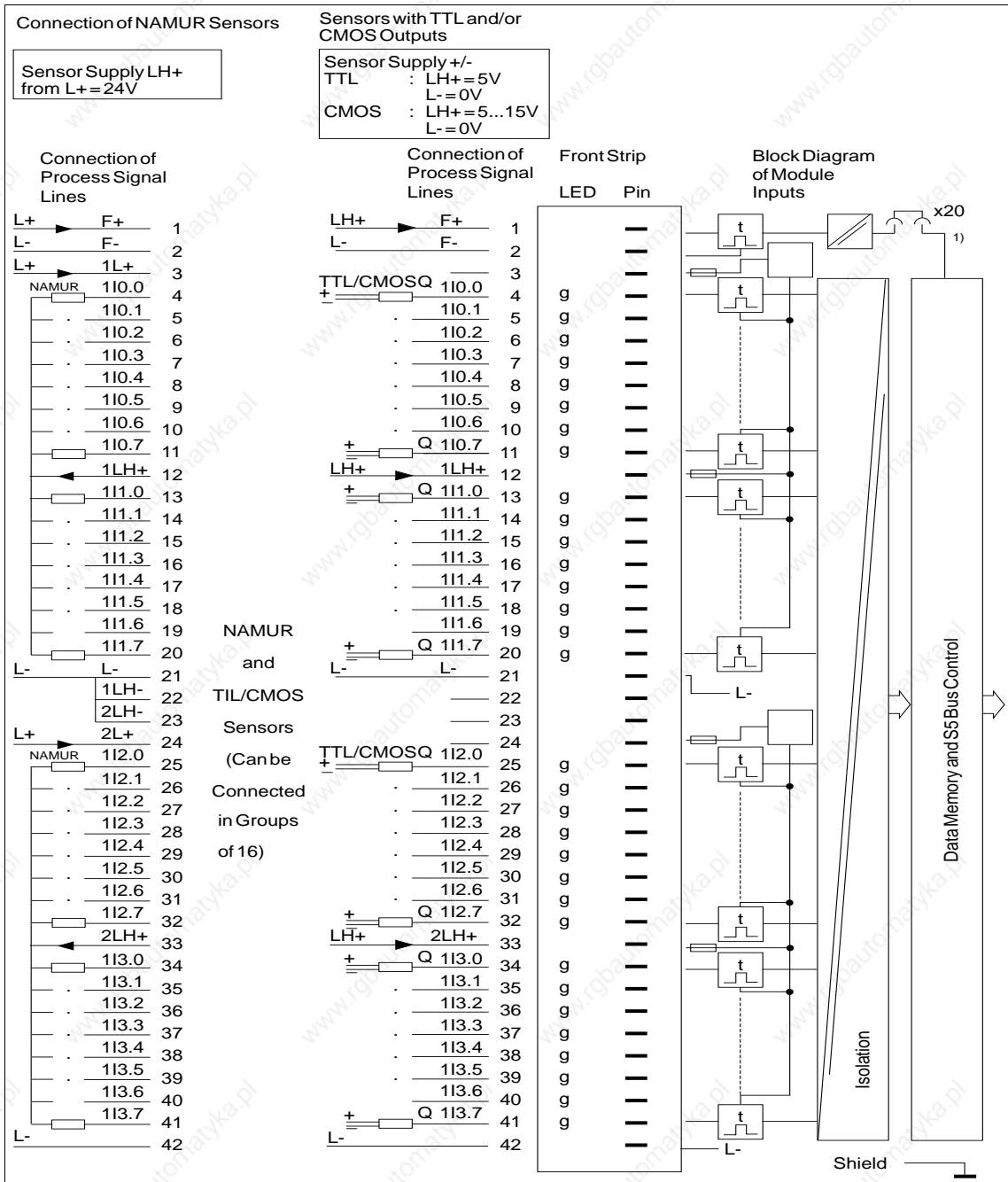

Example of connection designation for an input:

g = Green LED (status indicator)  
 F+/F- = Enable input

- 1) Changeover of enable mode with jumper X20:  
 Jumper inserted = Enable input active (factory setting)  
 Jumper open = Enable input inactive.

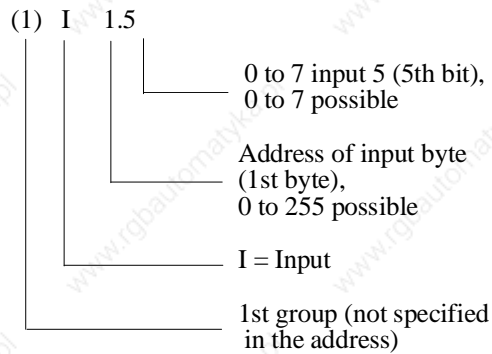

### 8.4.6 6ES5 435-4UA12 Digital Input Module

Rated input voltage	24 to 60 V AC (47 to 63 Hz)
Number of inputs	16
Isolation	Yes, 2 groups of 8 inputs
Input voltage for logic 0 for logic 1	0 to 15 V AC 20 to 72 V AC
Rated input current at 48 V AC at 60 V AC	15 mA typical 20 mA typical
Input current for 2-wire BERO for logic 0 for logic 1	≤ 5 mA ≥ 10 mA
Input frequency	20 Hz max. as pulse train
Delay time for positive-going edge for negative-going edge	5 ms typical (2 to 15 ms) 20 ms typical (10 to 25 ms)
Input resistance	3 kilohms typical
Coincidence factor (total load capability) ventilated not ventilated	100 % 75 % at 60 V 100 % at 35 °C 100 % at 30 V
Permissible line length	600 m max. unshielded 1000 m max. shielded
<b>Power supply</b>	
Digital section from system bus	5 V, 100 mA typical
Power dissipation (rated operation)	3.5 W at 24 V, 18.0 W at 60 V
<b>Enable input (F+/F-)</b>	Jumper in front connector
Voltage test to VDE 0160	Between two groups: 2000 V AC Between group and ground point: 1500 V AC
<b>Mechanical specifications</b>	
Dimensions (W x H x D)	40 mm x 255 mm x 195 mm
Weight	Approx. 0.55 kg

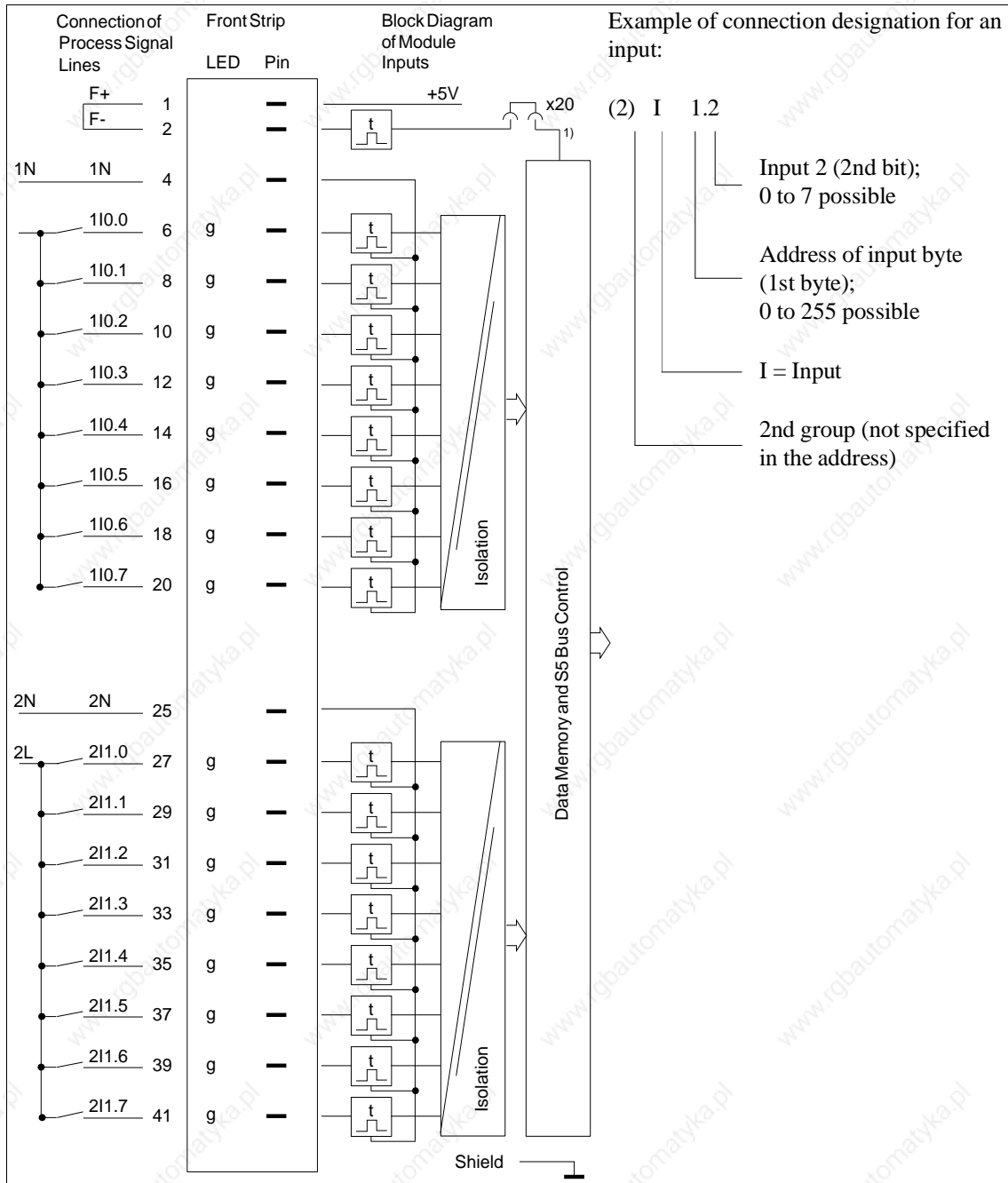

g = Green LED (status indicator)  
 F+/F- = Enable input (jumper in front connector)

- 1) Changeover of enable mode with jumper X20:  
 Jumper inserted = Enable input active (factory setting)  
 Jumper open = Enable input inactive.

### 8.4.7 6ES5 436-4UA12 Digital Input Module

Rated input voltage	115 to 230 V AC (47 to 63 Hz)
Number of inputs	16
Isolation	Yes, 2 groups of 8 inputs
Input voltage for logic 0 for logic 1	0 to 60 V AC 90 to 264 V AC
Rated input current at 115 V AC at 230 V AC	15 mA typical 25 mA typical (2-wire BERO can be connected)
Input frequency	20 Hz max. as pulse train
Delay time for positive-going edge for negative-going edge	5 ms typical (2 to 15 ms) 20 ms typical (10 to 25 ms)
Input resistance	10 kilohms typical
Coincidence factor (total load capability) ventilated not ventilated	100 % 75 % at 230 V AC 100 % at 35 °C 100 % at 115 V AC
Permissible line length	600 m max. unshielded 1000 m max. shielded
<b>Power supply</b>	
Digital section from system bus	5 V, 100 mA typical
Power dissipation (rated operation)	3.5 W at 115 V, 17.0 W at 230 V
<b>Enable input (F+/F-)</b>	Jumper in front connector
Voltage test to VDE 0160	Between two groups: 2000 V AC Between group and ground point: 1500 V AC
<b>Mechanical specifications</b>	
Dimensions (W x H x D)	40 mm x 255 mm x 195 mm
Weight	Approx. 0.55 kg

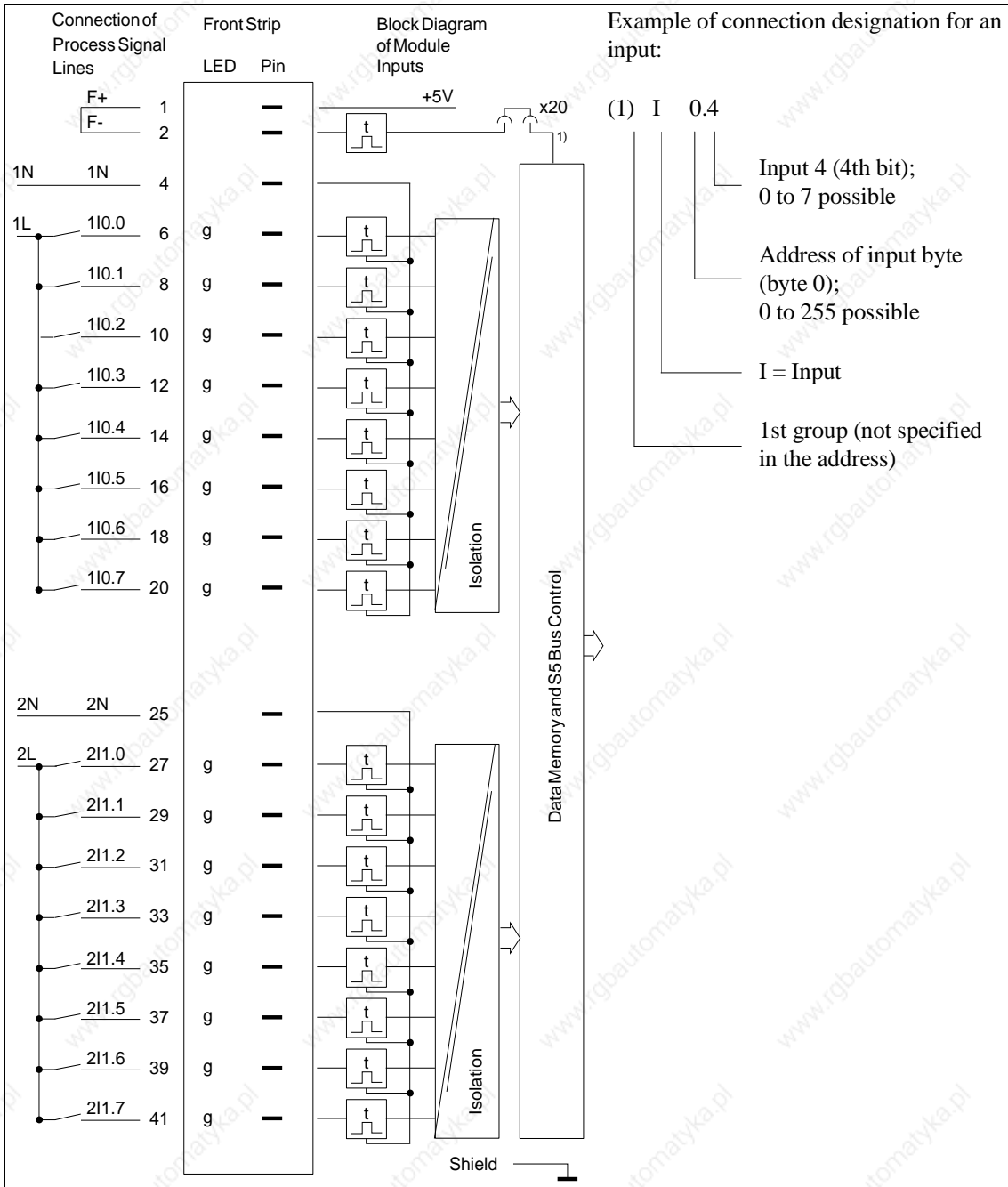

g = Green LED (status indicator)  
 F+/F- = Enable input (jumper in front connector)

- 1) Changeover of enable mode with jumper X20:  
 Jumper inserted = Enable input active (factory setting)  
 Jumper open = Enable input inactive.



### 8.4.8 6ES5 436-4UB12 Digital Input Module

Rated input voltage	115 to 230 V AC (47 to 63 Hz)
Number of inputs	8
Isolation	Yes, 8 inputs
Input voltage for logic 0 for logic 1	0 to 60 V AC 90 to 264 V AC
Rated input current at 115 V AC at 230 V AC	15 mA typical 25 mA typical (2-wire BERO can be connected)
Input frequency	20 Hz max. as pulse train
Delay time for positive-going edge for negative-going edge	5 ms typical (2 to 15 ms) 20 ms typical (10 to 25 ms)
Input resistance	10 kilohms typical
Coincidence factor (total load capability)	100 %
Permissible line length	600 m max. unshielded 1000 m max. shielded
<b>Power supply</b>	
Digital section from system bus	5 V, 80 mA typical
Power dissipation (rated operation)	2.0 W at 115 V, 8.5 W at 230 V
<b>Enable input (F+/F-)</b>	Jumper in front connector
Voltage test to VDE 0160	Between two groups: 2000 V AC Between group and ground point: 1500 V AC
<b>Mechanical specifications</b>	
Dimensions (W x H x D)	40 mm x 255 mm x 195 mm
Weight	Approx. 0.5 kg

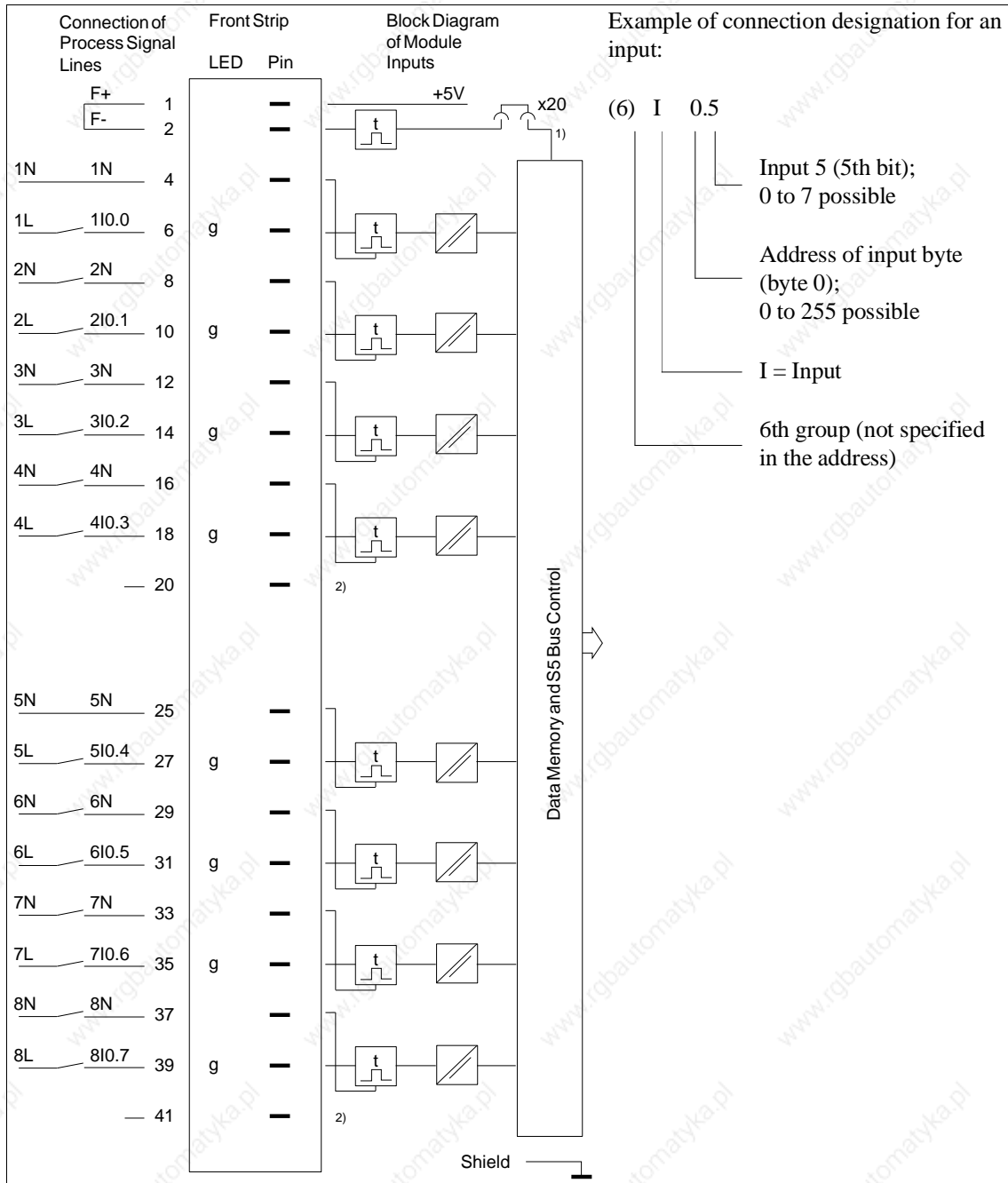

g = Green LED (status indicator)  
 F+/F- = Enable input (jumper in front connector)

- 1) Changeover of enable mode with jumper X20:  
 Jumper inserted = Enable input active (factory setting)  
 Jumper open = Enable input inactive.
- 2) The terminal is not connected internally. When this terminal is connected to input voltages, the clearances in air and leakage paths remain adequate to UL, CSA and VDE.

### 8.4.9 6ES5 441-4UA13 Digital Output Module

Rated supply voltage L+	24 V DC
Number of outputs	32, short-circuit protected <sup>1)</sup>
Isolation	no
Range for supply voltage	20 to 30 V DC
Fusing	6.3 A slow, 1 fuse per 8 outputs
Output voltage for logic 1 for logic 0	L+ -1.5 V min. 3 V max.
Switching current (resistive, inductive load)	5 mA to 0.5 A
Residual current at logic 0	0.5 mA max.
Switching current for lamps	0.22 A max. (5 W)
Switching frequency with resistive load with inductive load	100 Hz max. 2 Hz max. at 0.3 A, 0.5 Hz max. at 0.5 A
Breaking voltage (inductive)	Limited to L+ - 47 V
Total switching current	4 A max. per 8 outputs
Coincidence factor (total load capability) ventilated not ventilated	100 % 50 %, 100 % up to 35 °C
Permissible line length	400 m max. unshielded
<b>Power supply</b>	
Digital section from system bus	5 V, 80 mA typical
Current consumption from L+/L-	24 V, 150 mA typical
Power dissipation (rated operation)	17.0 W
<b>Enable input (F+/F-)</b>	
Rated input voltage	24 V DC
Input voltage for logic 1 for logic 0	13 to 33 V - 33 to 5 V
Rated input current	5 mA
Permissible line length	200 m max.
<b>Short-circuit monitoring</b>	
Indicator for signalling output (H+)	Red LED for every 8 outputs
Output voltage referred to L- (with feed at 1L+) for logic 1 for logic 0	1L+ - 5 V min. 3 V max.
Switching current	10 mA max., limited
<b>Mechanical specifications</b>	
Dimensions (W x H x D)	20 mm x 255 mm x 195 mm
Weight	Approx. 0.45 kg

1) Short-circuit protection responds with line resistance  $\leq 15$  ohms

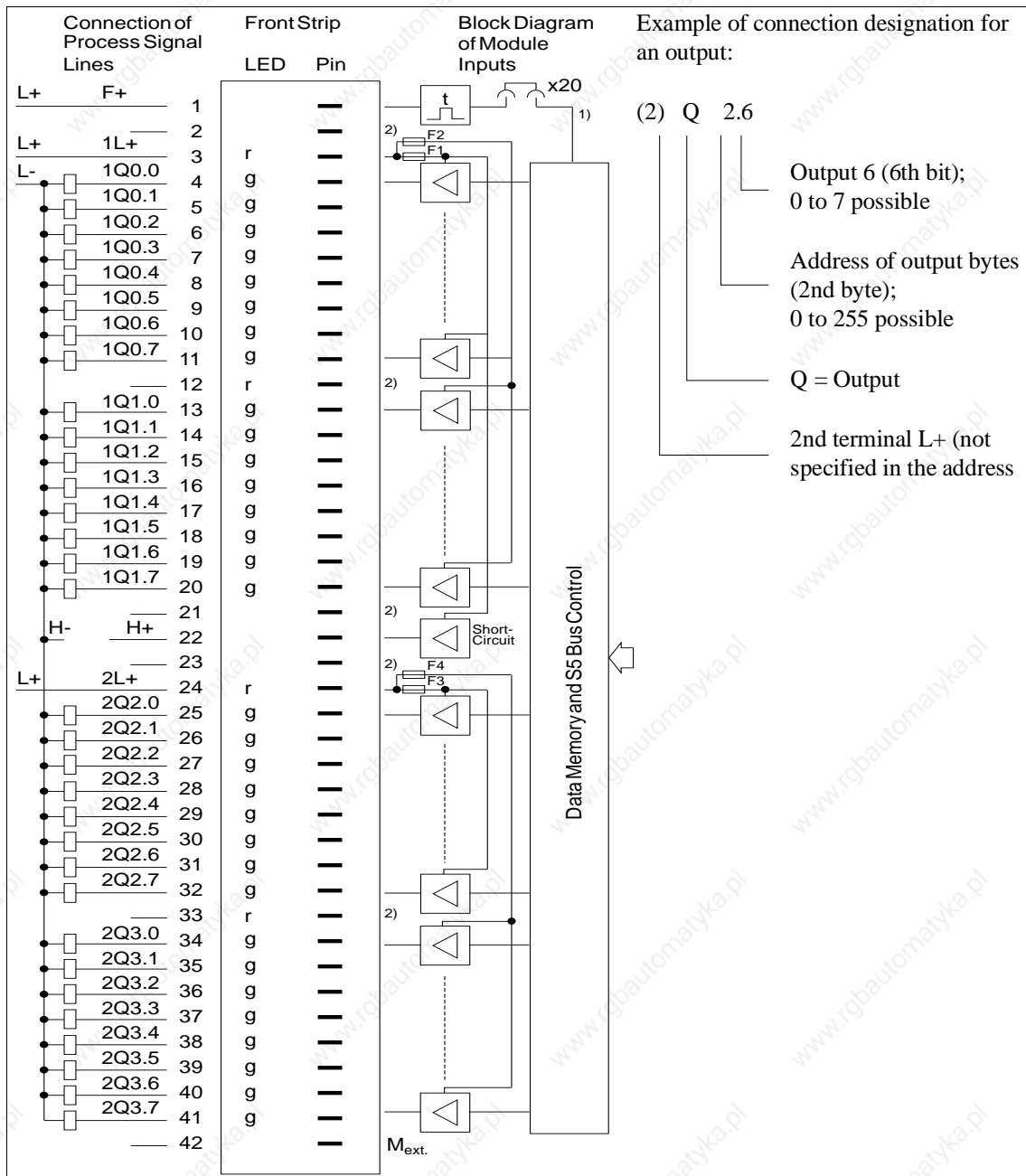

- g = Green LED (status indicator)
- r = Red LED (short-circuit indicator)
- F+ = Enable input, referred to 0 V ground

Connect L- of the power supply unit to the reference potential (PE).

- 1) Changeover of enable mode with jumper X20:  
 Jumper inserted = Enable input active (factory setting)  
 Jumper open = Enable input inactive.
- 2) The terminal is not connected internally. When this terminal is connected to the output voltages, the clearances in air and leakage paths are no longer adequate to UL and CSA, but comply with VDE.

#### 8.4.10 6ES5 451-4UA13 Digital Output Module

Rated supply voltage L+	24 V DC
Number of outputs	32, short-circuit protected <sup>1)</sup>
Isolation	Yes, 1 group of 32 outputs
Range for supply voltage	20 to 30 V DC
Fusing	6.3 A slow, 1 fuse per 8 outputs
Output voltage for logic 1 for logic 0	L+ -1.5 V min. 3 V max.
Switching current (resistive, inductive load)	5 mA to 0.5 A
Residual current at logic 0	0.5 mA max.
Switching current for lamps	0.22 A max. (5 W)
Switching frequency with resistive load with inductive load	100 Hz max. 2 Hz max. at 0.3 A, 0.5 Hz max. at 0.5 A
Breaking voltage (inductive)	Limited to L+ - 47 V
Total switching current	4 A max. per 8 outputs
Coincidence factor (total load capability) ventilated not ventilated	100 % 50 %, 100 % up to 35 °C
Permissible line length	400 m max. unshielded
<b>Power supply</b>	
Digital section from system bus	5 V, 80 mA typical
Current consumption from L+/L-	24 V, 150 mA typical
Power dissipation (rated operation)	17.0 W
<b>Enable input (F+/F-)</b>	
Rated input voltage	24 V DC
Input voltage for logic 1 for logic 0	13 to 33 V - 33 to 5 V
Rated input current	5 mA
Permissible line length	200 m max.
<b>Short-circuit monitoring</b>	
Indicator for signalling output (H+)	Red LED for every 8 outputs
Output voltage referred to L- (with feed at 1L+) for logic 1 for logic 0	1L+ - 5 V min. 3 V max.
Switching current	10 mA max., limited
Voltage test to VDE 0160	Between group and ground point: 1250 V AC
<b>Mechanical specifications</b>	
Dimensions (W x H x D)	20 mm x 255 mm x 195 mm
Weight	Approx. 0.45 kg

1) Short-circuit protection responds with line resistance  $\leq 15$  ohms

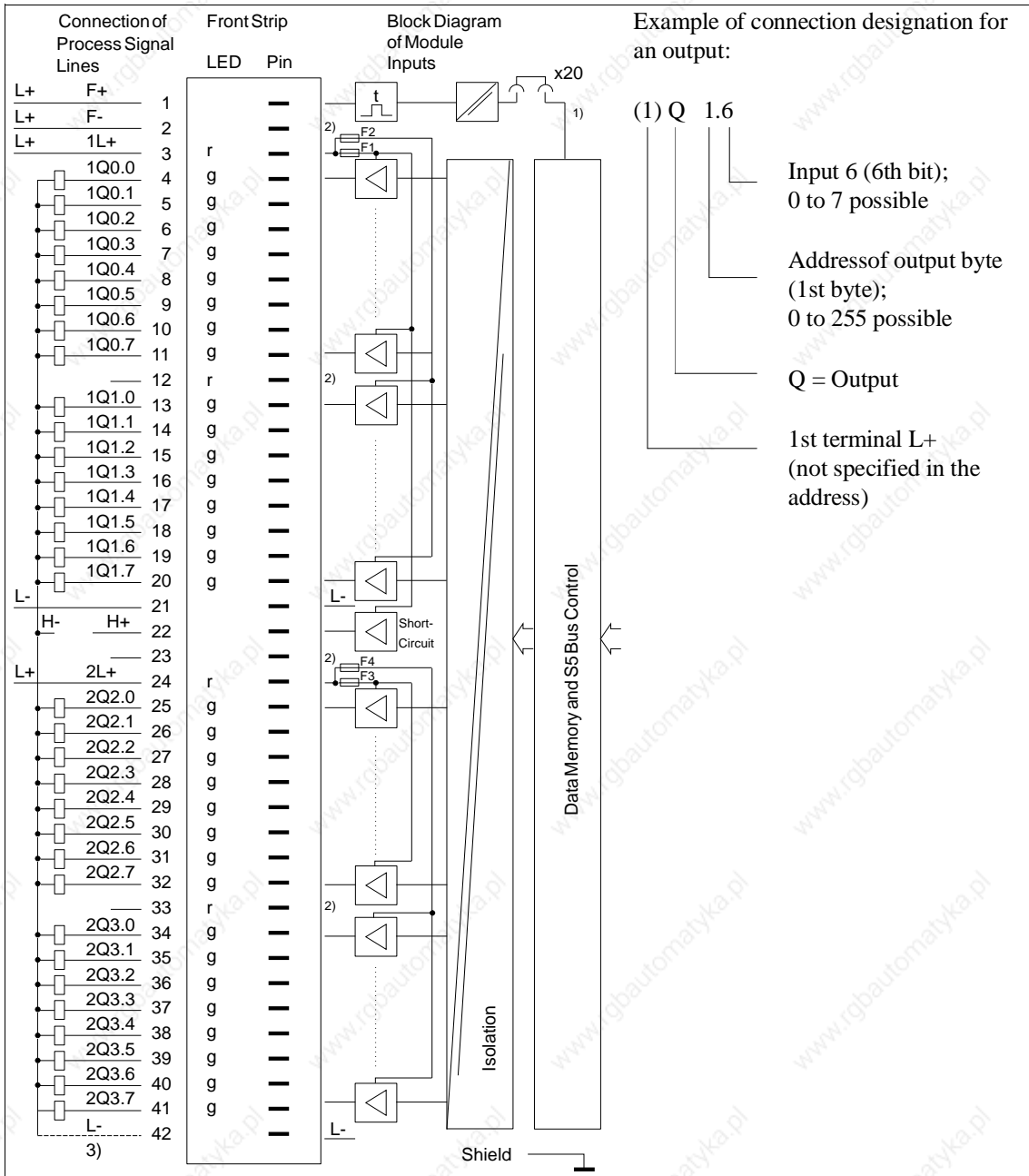

g = Green LED (status indicator)  
 r = Red LED (short-circuit indicator)  
 F+/F- = Enable input

- 1) Changeover of enable mode with jumper X20:  
 Jumper inserted = Enable input active (factory setting)  
 Jumper open = Enable input inactive.
- 2) The terminal is not connected internally. When this terminal is connected to the output voltages, the clearances in air and leakage paths are no longer adequate to UL and CSA, but comply with VDE.
- 3) By connecting L- to pin 42, a leading and trailing connection to 0 V ground is created on the module when it is inserted and removed.

### 8.4.11 6ES5 453-4UA12 Digital Output Module

Rated supply voltage L+	24 V DC
Number of outputs (decoupled via diodes)	16, short-circuit protected <sup>1)</sup>
Isolation	Yes, 16 outputs
Range for supply voltage	20 to 30 V DC
Fusing	16 x 2.5 A, slow
Output voltage	for logic 1: (L+) switch (L-) switch for logic 0: (L+) switch (L-) switch
	- 2.5 V min. 2.5 V max. 3 V max. L+ - 3 V min.
Switching current (resistive, inductive load)	10 mA to 2.0 A <sup>2)</sup>
Residual current at logic 0	1 mA max.
Switching current for lamps	0.45 A max. (10 W)
Switching frequency	with resistive load with inductive load
	100 Hz max. 0.2 Hz max. at 1 A, 0.1 Hz at 2 A
Breaking voltage (inductive)	Limited to L+ - 47 V
Total switching current	max. per 8 outputs
Coincidence factor (total load capability)	
ventilated	100 %
not ventilated	25 %, 50 % up to 20 °C
Permissible line length	400 m max. unshielded
<b>Power supply</b>	
Digital section from system bus	5 V, 120 mA typical
Power dissipation (rated operation)	49.0 W
<b>Enable input (F+/F-)</b>	
Rated input voltage	24 V DC
Input voltage	for logic 1 for logic 0
	13 to 33 V - 33 to 5 V
Rated input current	5 mA
Permissible line length	200 m max.
<b>Short-circuit monitoring</b>	
Indicator for signalling output (H+, H-) floating	Red LED for 16 outputs
Output voltage as L+ switch	
for logic 1	L+ - 5 V min.
for logic 0	3 V max.
Switching current	10 mA max., short-circuit protected
Voltage test to VDE 0160	Between two groups: 1250 V AC Between group and ground point: 1250 V AC
<b>Mechanical specifications</b>	
Dimensions (W x H x D)	40 mm x 255 mm x 195 mm
Weight	Approx. 0.6 kg

- 1) Short-circuit protection responds with line resistance  $\leq 3.6$  ohms.
- 2) One digital input is permissible as minimum load.

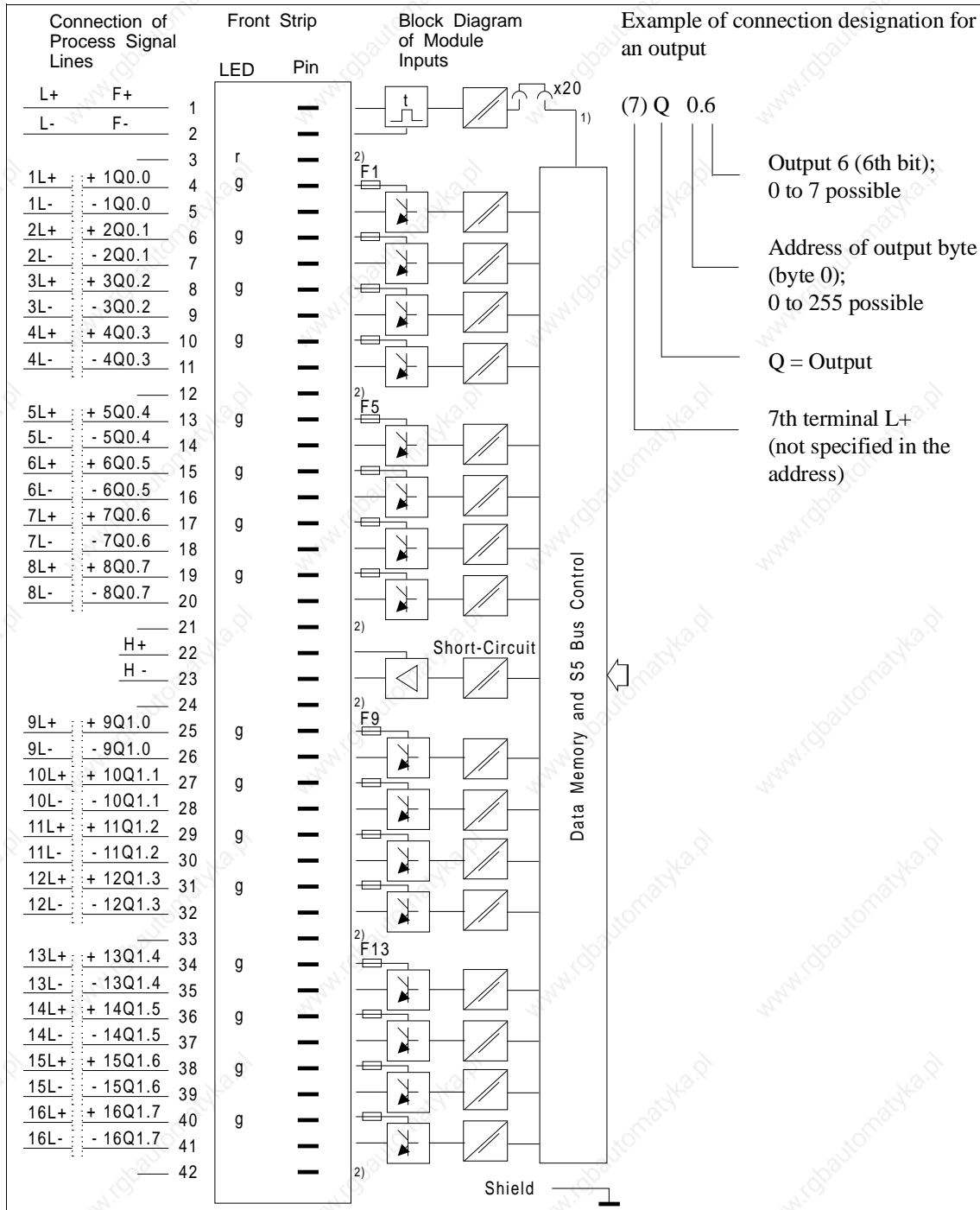

g = Green LED (status indicator)  
 r = Red LED (short-circuit indicator)  
 F+/F- = Enable input

- 1) Changeover of enable mode with jumper X20:  
 Jumper inserted = Enable input active (factory setting)  
 Jumper open = Enable input inactive.
- 2) The terminal is not connected internally. When this terminal is connected to the output voltages, the clearances in air and leakage paths are no longer adequate to UL and CSA, but comply with VDE.



#### 8.4.12 6ES5 454-4UA13 Digital Output Module

Rated supply voltage L+	24 V DC
Number of outputs	16, short-circuit protected <sup>1)</sup>
Isolation	Yes, 1 group of 16 outputs
Range for supply voltage	20 to 30 V DC
Fusing	6.3 A slow, 1 fuse per 4 outputs
Output voltage for logic 1 for logic 0	L + - 2 V min. 3 V max.
Switching current (resistive, inductive load)	10 mA to 2 A <sup>2)</sup>
Residual current at logic 0	1 mA max.
Switching current for lamps	0.45 A max. (10 W)
Switching frequency with resistive load with inductive load	100 Hz max. 0.2 Hz max. at 1 A, 0.1 Hz at 2 A
Breaking voltage (inductive)	Limited to L+ - 47 V
Total switching current	4 A max. per 4 outputs
Coincidence factor (total load capability)	50 %
Permissible line length	400 m max. unshielded
<b>Power supply</b>	
Digital section from system bus	5 V, 100 mA typical
Current consumption from L+/L-	24 V, 100 mA typical
Power dissipation (rated operation)	17.5 W
<b>Enable input (F+/F-)</b>	
Rated input voltage	24 V DC
Input voltage for logic 1 for logic 0	13 to 33 V - 33 to 5 V
Rated input current	5 mA
Permissible line length	200 m max.
<b>Short-circuit monitoring</b>	
Indicator for signalling output (H+)	Red LED for 4 outputs
Output voltage referred to L- (with feed at 1L+) for logic 1 for logic 0	1L+ - 5 V min. 3 V max.
Switching current	10 mA max., limited
Voltage test to VDE 0160	Between two groups: 1250 V AC Between group and ground point: 1250 V AC
<b>Mechanical specifications</b>	
Dimensions (W x H x D)	40 mm x 255 mm x 195 mm
Weight	Approx. 0.55 kg

- 1) Short-circuit protection responds with line resistance  $\leq 4.75$  ohms
- 2) One digital input is permissible as minimum load.

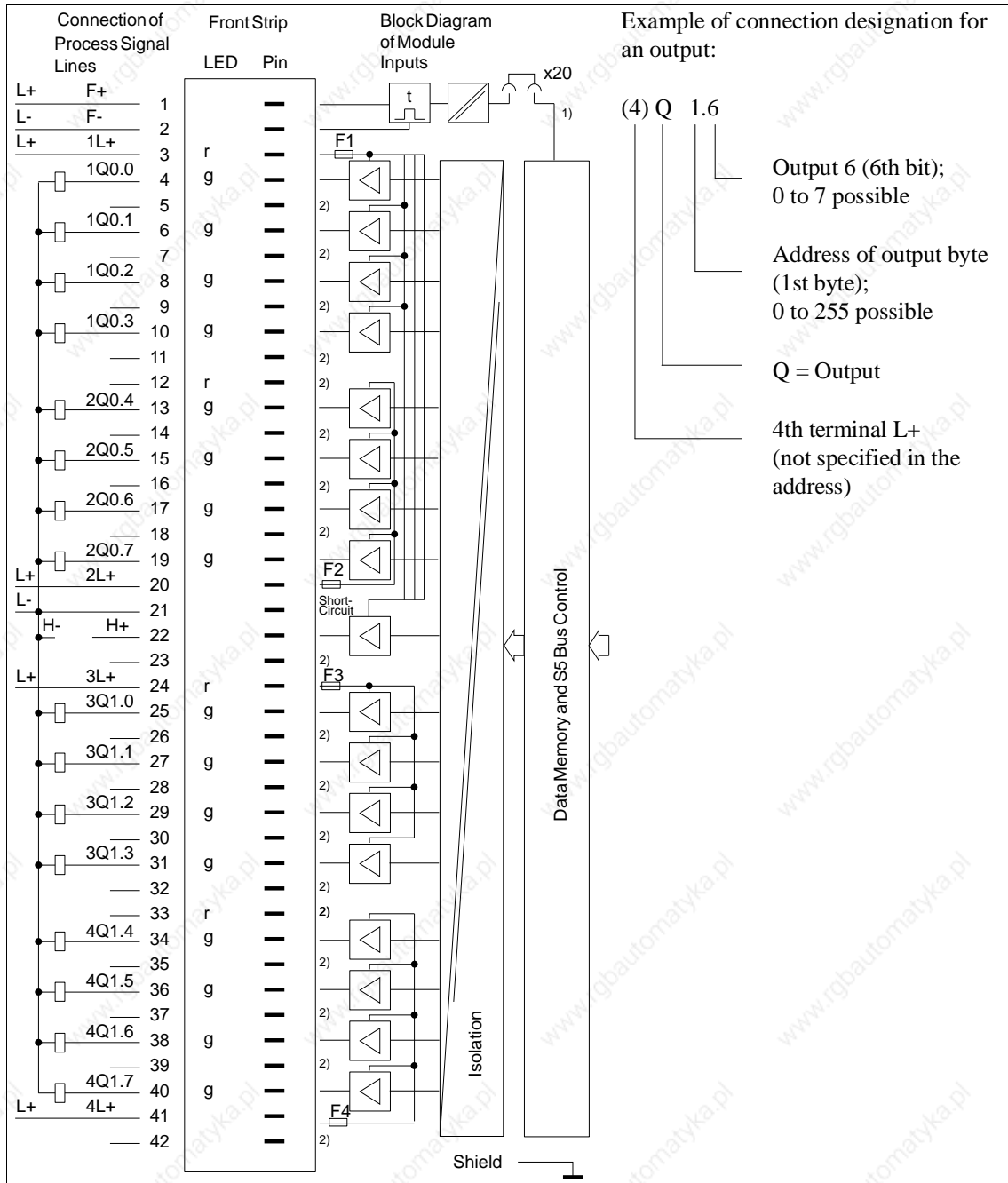

g = Green LED (status indicator)  
 r = Red LED (short-circuit indicator)  
 F+/F- = Enable input

- 1) Changeover of enable mode with jumper X20:  
 Jumper inserted = Enable input active (factory setting)  
 Jumper open = Enable input inactive.
- 2) The terminal is not connected internally. When this terminal is connected to the output voltages, the clearances in air and leakage paths are no longer adequate to UL and CSA, but comply with VDE.

### 8.4.13 6ES5 455-4UA12 Digital Output Module

Rated supply voltage L	24 to 60 V AC (47 to 63 Hz)
Number of outputs	16, conditional short-circuit protection <sup>1)</sup>
Isolation	Yes, 2 groups of 8 outputs
Range for supply voltage	20 to 72 V AC
Fusing	6.3 A fast, 1 fuse per 4 outputs
Output voltage for logic 1 for logic 0	L- 1.5 V min. 7.5 V max.
Residual current at logic 0	5 mA max.
Switching current (resistive, inductive load) ventilated not ventilated	40 mA to 2 A, 6 A max. per 4 outputs 40 mA to 1 A, 4 A max. per 4 outputs
Switching current for lamps ventilated not ventilated	40 mA to 2 A, 2.5 A max. per 4 outputs 40 mA to 1 A, 2.5 A max. per 4 outputs
Max. inrush current for ≤ 3 ms ≤ 20 ms ≤ 50 ms	25 A/group 15 A/group 13 A/group
Permissible line length	300 m max. unshielded
<b>Power supply</b>	
Digital section from system bus	5 V, 100 mA typical
Power dissipation (rated operation)	39.0 W
<b>Enable input (F+/F-)</b>	
Voltage test to VDE 0160	Between two groups: 2000 V AC Between group and ground point: 1500 V AC
<b>Mechanical specifications</b>	
Dimensions (W x H x D)	40 mm x 255 mm x 195 mm
Weight	Approx. 0.7 kg

1) Protected by a fuse

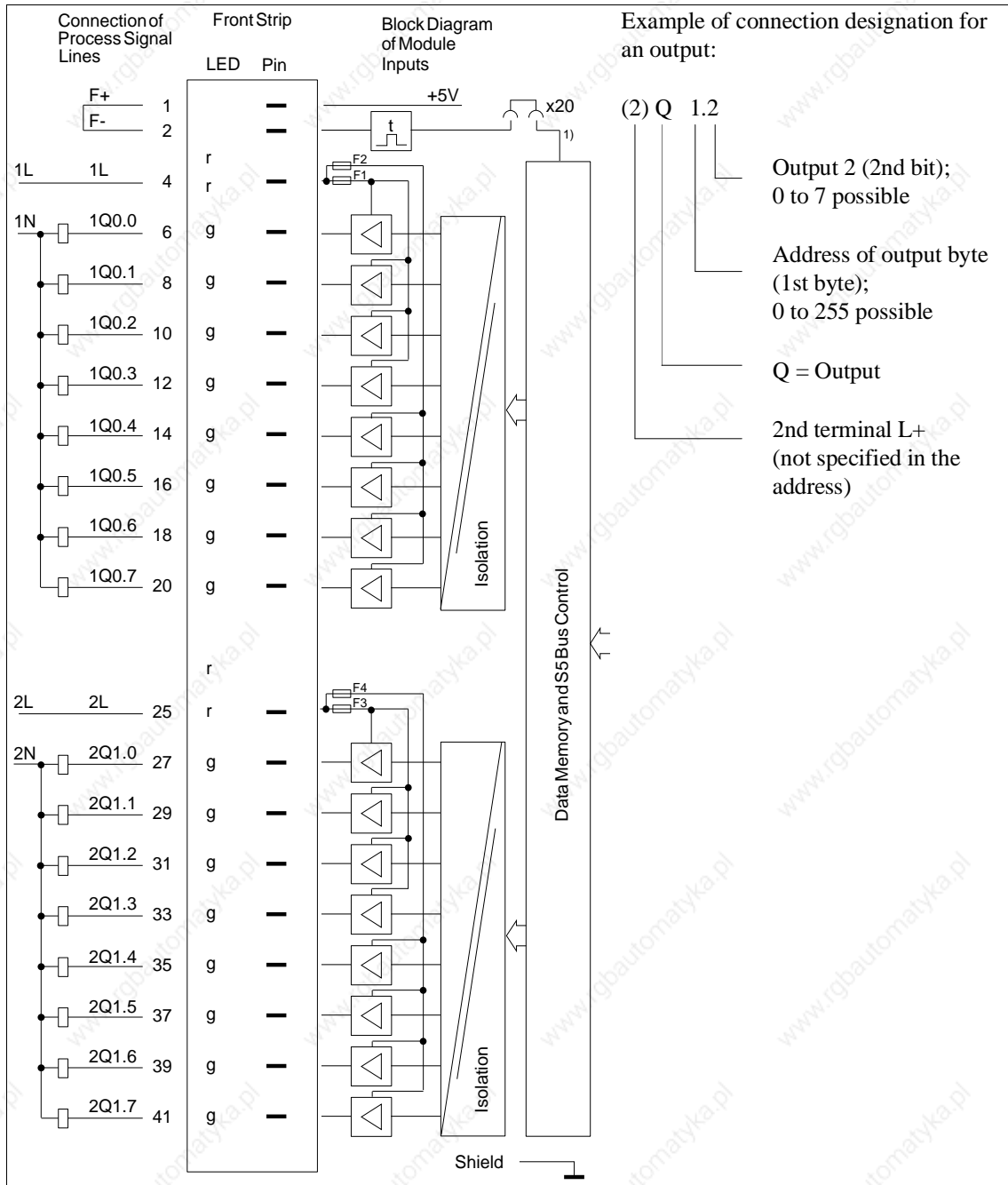

g = Green LED (status indicator)  
 r = Red LED (short-circuit indicator)  
 F+/F- = Enable input

- 1) Changeover of enable mode with jumper X20:  
 Jumper inserted = Enable input active (factory setting)  
 Jumper open = Enable input inactive.

#### 8.4.14 6ES5 456-4UA12 Digital Output Module

Rated supply voltage L	115 to 230 V AC (47 to 63 Hz)
Number of outputs	16, conditional short-circuit protection <sup>1)</sup>
Isolation	Yes, 2 groups of 8 outputs
Range for supply voltage	88 to 264 V AC
Fusing	6.3 A fast, 1 fuse per 4 outputs
Output voltage for logic 1 for logic 0	L- 1.5 V min. 30 V max.
Residual current at logic 0	5 mA max.
Switching current (resistive, inductive load) ventilated not ventilated	40 mA to 2 A; <sup>2)</sup> 6 A max. per 4 outputs 40 mA to 1 A; <sup>2)</sup> 4 A max. per 4 outputs
Switching current for lamps ventilated not ventilated	40 mA to 2 A, 2.5 A max. per 4 outputs 40 mA to 1 A, 2.5 A max. per 4 outputs
Contactor size per fuse group  for all outputs	0 (Type 3TB40) to 14 (Type 3TB58) at 230 V AC 00 (Type 3TJ..) to 10 (Type 3TB54) at 115 V AC  0 (Type 3TB40) to 8 (Type 3TB52) at 230 V AC 00 (Type 3TJ..) to 4 (Type 3TB48) at 115 V AC
Max. inrush current for ≤ 3 ms ≤ 20 ms ≤ 50 ms	25 A/group 15 A/group 13 A/group
Permissible line length	300 m max. unshielded
<b>Power supply</b>	
Digital section from system bus	5 V, 100 mA typical
Power dissipation (rated operation)	39.0 W
<b>Enable input (F+/F-)</b>	Jumper in front connector
Voltage test to VDE 0160	Between two groups: 2000 V AC Between group and ground point: 1500 V AC
<b>Mechanical specifications</b>	
Dimensions (W x H x D)	40 mm x 255 mm x 195 mm
Weight	Approx. 0.7 kg

- 1) Protected by a fuse
- 2) Contactors of Series 3TJ can only be operated at 115 V AC.

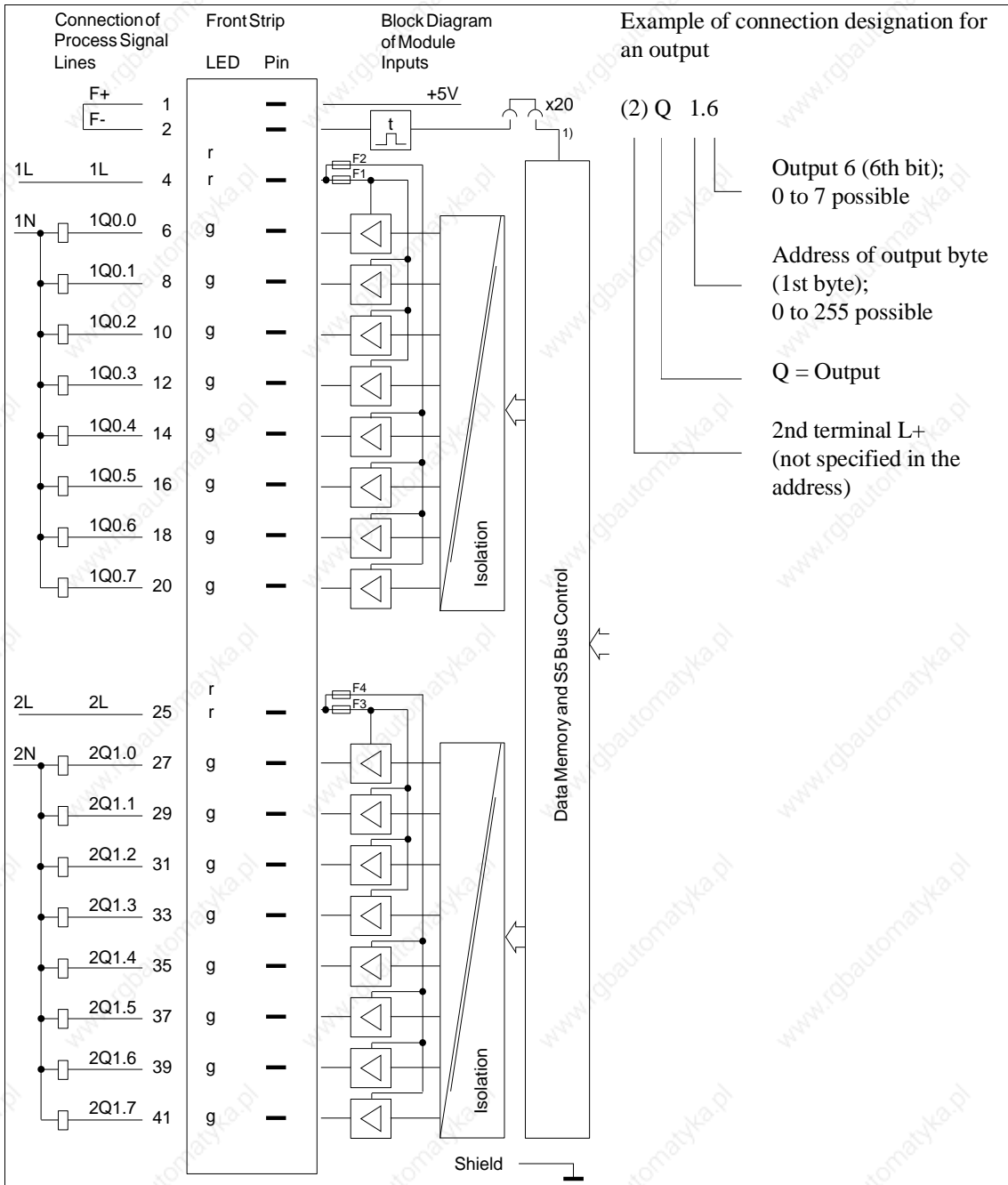

g = Green LED (status indicator)  
 r = Red LED (short-circuit indicator)  
 F+/F- = Enable input

- 1) Changeover of enable mode with jumper X20:  
 Jumper inserted = Enable input active (factory setting)  
 Jumper open = Enable input inactive.

#### 8.4.15 6ES5 456-4UB12 Digital Output Module

Rated supply voltage L	115 to 230 V AC (47 to 63 Hz)
Number of outputs	8, conditional short-circuit protection <sup>1)</sup>
Isolation	Yes, 8 outputs
Range for supply voltage	88 to 264 V AC
Fusing	3.5 A fast, 1 fuse per outputs
Output voltage for logic 1 for logic 0	L- 1.5 V min. 30 V max.
Residual current at logic 0	5 mA max.
Switching current (resistive, inductive load) ventilated not ventilated	40 mA to 2 A; <sup>2)</sup> 40 mA to 1 A; <sup>2)</sup>
Switching current for lamps ventilated not ventilated	40 mA to 2 A; 40 mA to 1 A;
Contacteur size	0 (Type 3TB40) to 14 (Type 3TB58) at 230 V AC; 00 (Type 3TJ..) to 8 (Type 3TB52) at 115 V AC;
Max. inrush current for ≤ 3 ms ≤ 20 ms ≤ 50 ms	16 A 8 A 6.5 A
Switching capacity per module for UL for CSA	1440 VA max. 2000 VA max.
Permissible line length	300 m max. unshielded
<b>Power supply</b>	
Digital section from system bus	5 V, 100 mA typical
Power dissipation (rated operation)	18.0 W
<b>Enable input (F+/F-)</b>	Jumper in front connector
Voltage test to VDE 0160	Between two groups: 2000 V AC Between group and ground point: 1500 V AC
<b>Mechanical specifications</b>	
Dimensions (W x H x D)	40 mm x 255 mm x 195 mm
Weight	Approx. 0.6 kg

- 1) Protected by a fuse
- 2) Contactors of Series 3TJ can only be operated at 115 V AC.

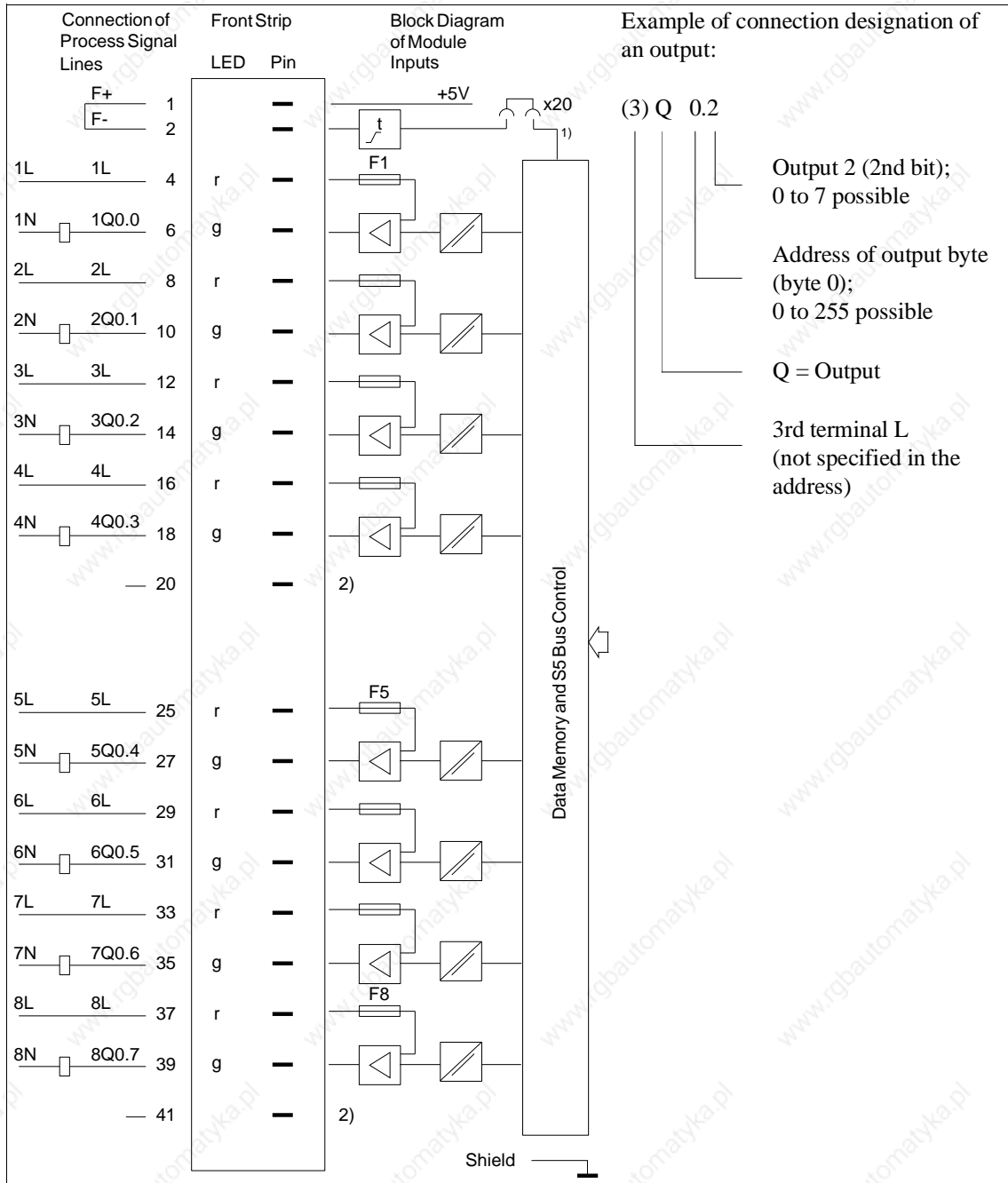

g = Green LED (status indicator)  
 r = Red LED (short-circuit indicator)  
 F+/F- = Enable input (jumper in front connector)

- 1) Changeover of enable mode with jumper X20:  
 Jumper inserted = Enable input active (factory setting)  
 Jumper open = Enable input inactive.
- 2) The terminal is not connected internally. If this terminal is connected to the output voltage, the clearances in air and leakage paths remain adequate to UL, CSA and VDE.



#### 8.4.16 6ES5 457-4UA12 Digital Output Module

Rated supply voltage L+	24 V to 60 V DC
Number of outputs (decoupled via diodes)	16, short-circuit protected <sup>1)</sup>
Isolation	Yes, 16 outputs
Range for supply voltage	20 to 72 V DC
Fusing	16 x 1 A, slow
Output voltage	for logic 1: (L+) switch (L-) switch for logic 0: (L+) switch (L-) switch
	L+ - 2.5 V min. 2.5 V max. 3 V max. L+ - 3 V min.
Switching current (resistive, inductive load)	5 mA to 0.5 A <sup>2)</sup>
Residual current at logic 0	1 mA max.
Switching current for lamps	0.22 A max. (5 W)
Switching frequency	with resistive load with inductive load
	100 Hz max. 2 Hz max. at 0.5 A
Breaking voltage (inductive)	Limited to L+ - 75 V <sup>3)</sup>
Coincidence factor (total load capability)	ventilated not ventilated
	100 % 50 %; 100 % bis 35 °C
Permissible line length	400 m max. unshielded
<b>Power supply</b>	
Digital section from system bus	5 V, 120 mA typical
Power dissipation (rated operation)	13.0 W
<b>Enable input (F+/F-)</b>	
Rated input voltage	24 to 60 V DC
Input voltage	for logic 1 for logic 0
	13 to 72 V - 72 to 8 V
Rated input current	at 24 V DC at 48 V DC at 60 V DC
	2.5 mA 5 mA 6.5 mA
Permissible line length	200 m max.
<b>Short-circuit monitoring</b>	
Indicator for signalling output (H+, H-)	Red LED for 16 outputs
Output voltage as L+ switch	for logic 1 for logic 0
	L+ - 5 V min. 3 V max.
Switching current	10 mA max., short-circuit protected
Voltage test to VDE 0160	Between two groups: 1250 V AC Between group and ground point: 1250 V AC
<b>Mechanical specifications</b>	
Dimensions (W x H x D)	40 mm x 255 mm x 195 mm
Weight	Approx. 0.6 kg

- 1) Short-circuit protection responds with line resistance  $\leq 9$  ohms at 24 V DC,  $\leq 30$  ohms at 60 V DC.
- 2) One digital input is permissible as minimum load.
- 3) At L+ voltages of more than 72 V, the logic 0 of the output can rise to 13 V. A digital input follower will interpret this signal as a logic 1 (possible fault).

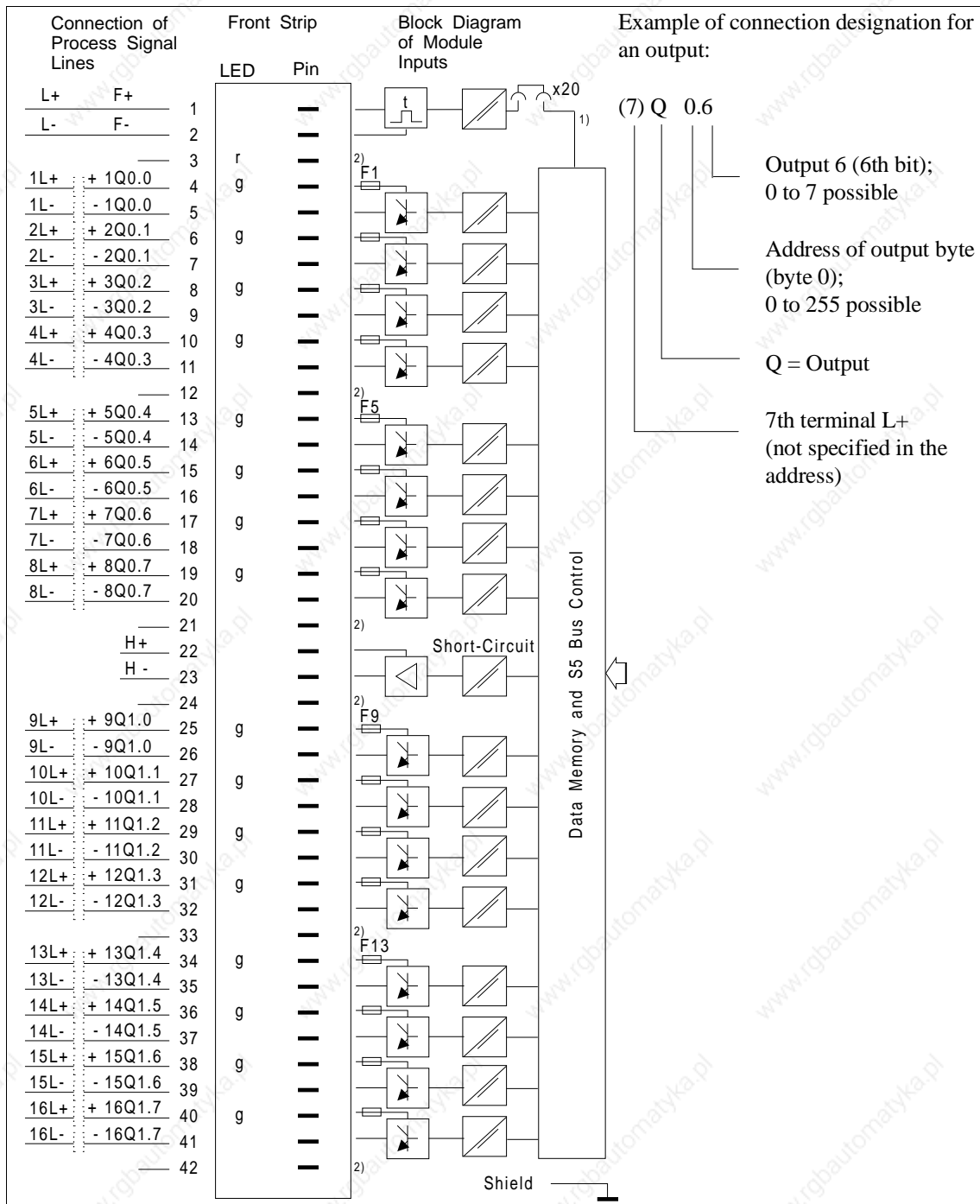

g = Green LED (status indicator)  
 r = Red LED (short-circuit indicator)  
 F+ = Enable input

- 1) Changeover of enable mode with jumper X20:  
 Jumper inserted = Enable input active (factory setting)  
 Jumper open = Enable input inactive.
- 2) The terminal is not connected internally. When this terminal is connected to the output voltages, the clearances in air and leakage paths are no longer adequate to UL and CSA, but comply with VDE.

#### 8.4.17 6ES5 458-4UA12 Digital Output Module

Rated supply voltage L	24 V DC
Number of outputs	16
Isolation	Yes, 16 outputs
Range for supply voltage	20 to 30 V DC
Fusing	16 x 1 A, slow <sup>1)</sup>
Output	Relay contacts
Service life of contacts	10 <sup>8</sup> cycles
Switching capacity with resistive load with RC element module without RC element module	60 V DC/48 V AC, 0.5 A <sup>2)</sup> 60 V DC/48 V AC, 70 mA
Switching current with inductive load with RC element module and external suppressor circuit	0.5 A max.
Switching current for lamps	0.1 A max. with RC element module
Switching frequency with resistive load  with inductive load	100 Hz max. (pick-up 1 ms, drop-out 1 ms)  10 Hz max. up to 50 mA 2 Hz max. up to 0.3 A 0.5 Hz max. up to 0.5 A
Coincidence factor (total load capability)	100 %
Permissible line length	400 m max., unshielded
<b>Power supply</b>	
Digital section from system bus	5 V, 80 mA typical
Current consumption from L+/L-	200 mA typical
Power dissipation (rated operation)	5.2 W
<b>Enable input (F+/F-)</b>	
Rated input voltage	24 V DC
Input voltage for logic 1 for logic 0	13 to 33 V - 33 to 5 V
Rated input current	5 mA
Permissible line length	200 m max.
Voltage test to VDE 0160	Between two groups: 500 V AC Between group and ground point: 500 V AC
<b>Mechanical specifications</b>	
Dimensions (W x H x D)	20 mm x 255 mm x 195 mm
Weight	Approx. 0.45 kg

- 1) The fuse does not protect the contacts. The relay must be replaced after an overload.
- 2) 50 V/0.5 A max. resistive load for UL

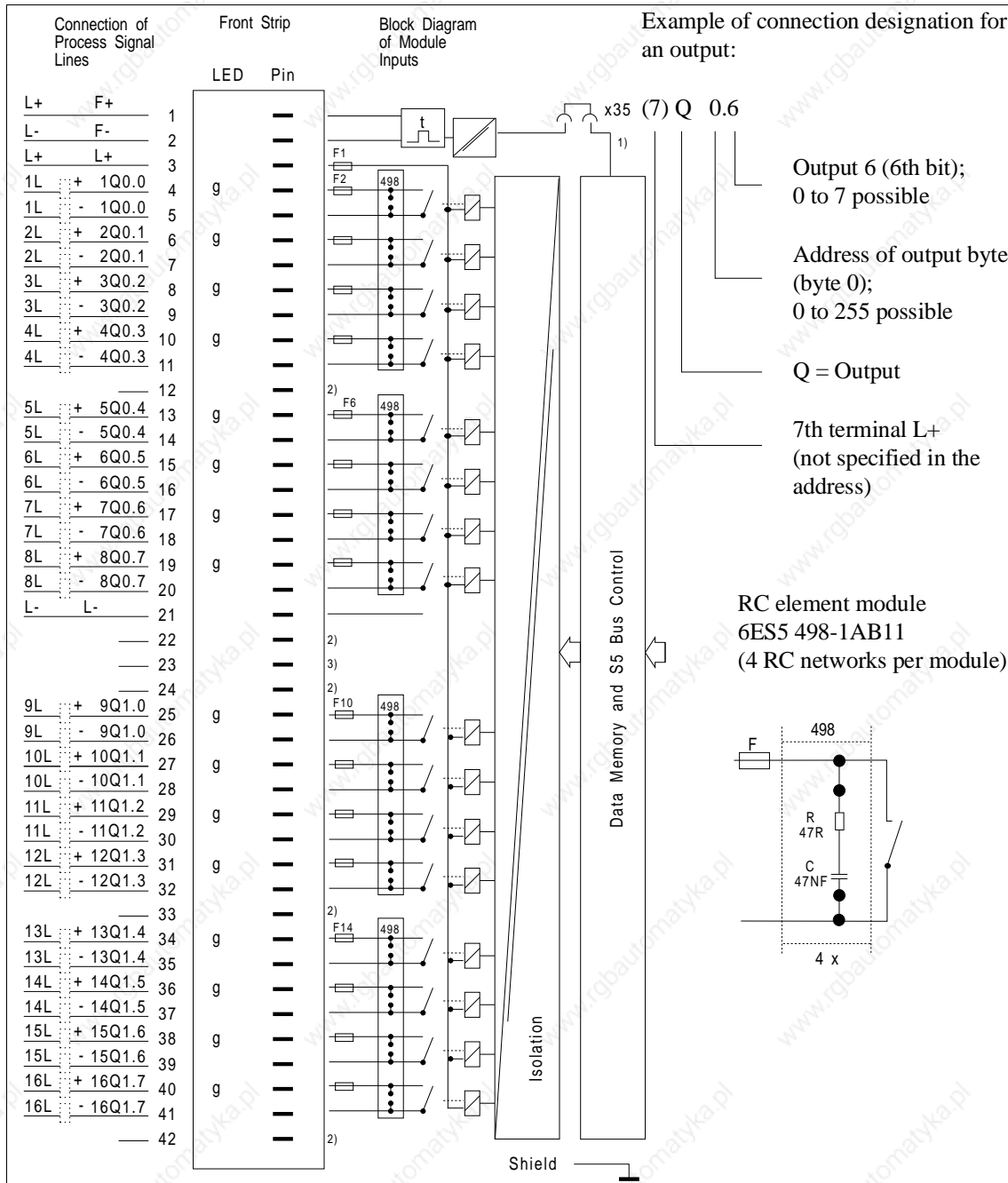

g = Green LED (status indicator)  
 r = Red LED (short-circuit indicator)  
 F+ = Enable input

- 1) Changeover of enable mode with jumper X35:  
 Jumper inserted = Enable input active (factory setting)  
 Jumper open = Enable input inactive.
- 2) The terminal is not connected internally. When this terminal is connected to the output voltages, the clearances in air and leakage paths are no longer adequate to UL and CSA, but comply with VDE.
- 3) The terminal is not connected internally. If this terminal is connected to the output voltages, the clearances in air and leakage paths remain adequate to UL, CSA and VDE.

External suppressor circuitry  
for inductive load

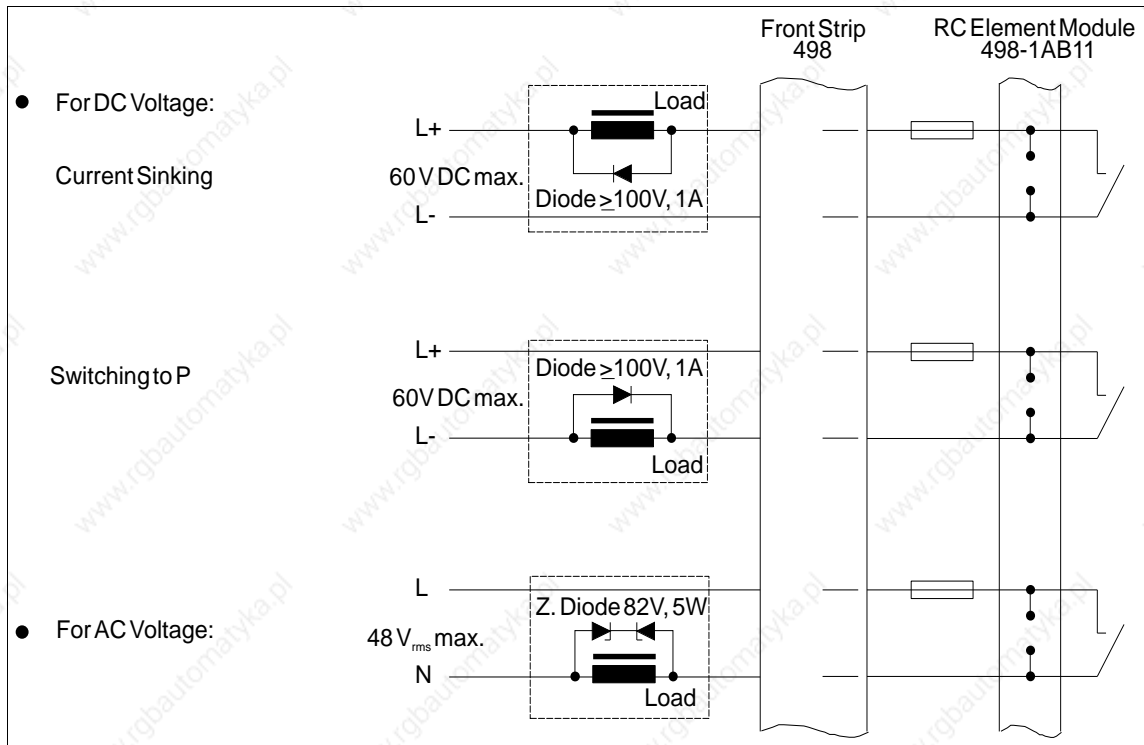

#### 8.4.18 6ES5 458-4UC11 Digital Output Module

Rated supply voltage L	24 V DC (pins 22, 23)
Number of outputs	16
Isolation	Yes, 2 groups of 8 outputs
Range for supply voltage of the relays	20 to 30 V DC
Output	Relay contacts
Service life of contacts	Approx. $10^5$ cycles at 230 V AC/5 A Approx. $10^7$ cycles mechanical
Switching capacity of the contacts with resistive load	5.0 A at 250 V AC 5.0 A at 30 V DC 0.3 A at 115 V DC
with inductive load	1.5 A at 250 V AC 1.0 A at 30 V DC 0.08 A at 115 V DC
Max. rating per group P0/P1	8.0 A
Switching frequency with resistive load with inductive load	10 Hz max. 2 Hz max.
Permissible line length	400 m max., unshielded
<b>Power supply</b>	
Digital section from system bus	5 V, 120 mA typical (all outputs active)
Current consumption from L+/L-	250 mA typical (all outputs active)
Power dissipation (rated operation)	6.6 W
<b>Enable input (F+/F-)</b>	
Rated input voltage	24 V DC
Input voltage for logic 1 for logic 0	13 to 33 V - 33 to 5 V
Rated input current	5 mA
Permissible line length	200 m max.
Voltage test to VDE 0160	Between two groups: 2000 V AC Between group and ground point: 1500 V AC
<b>Mechanical specifications</b>	
Dimensions (W x H x D)	20 mm x 255 mm x 195 mm
Weight	Approx. 0.7 kg

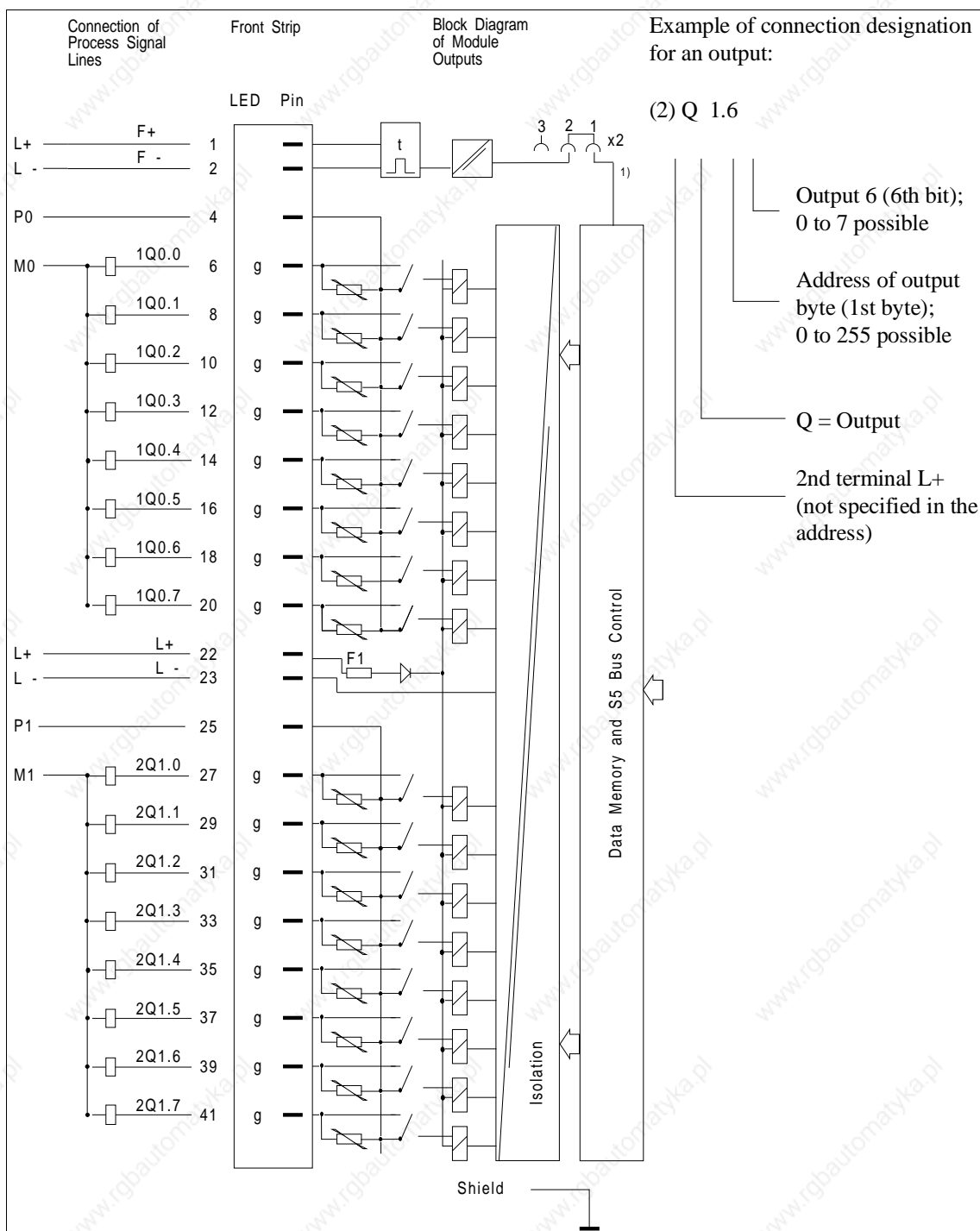

- g = Green LED (status indicator)
- F+/F- = Enable input
- P0/M0 = Group of 8/load supply voltage (1st group)
- P1/M1 = Group of 8/load supply voltage (2nd group)
- L+/L- = Relay supply voltage (24 V DC)

- 1) Changeover of enable mode with jumper X2: 1 - 2  
 Jumper inserted = Enable input active (factory setting)  
 Jumper open = Enable input inactive.

#### 8.4.19 6ES5 482-4UA11 Digital Input/Output Module

Rated supply voltage L+	24 V DC
Rated input voltage	24 V DC
<b>Inputs</b>	
Number of inputs	16 min., 24 max.
Isolation	Yes, 1 group of 32 inputs/outputs
Input voltage for logic 0 for logic 1	- 33 to 5 V 13 to 33 V
Rated input current	8.5 mA typical
Delay time	0.3 ms typical
Input resistance	2.8 kilohms typical
Coincidence factor (total load capability)	100 %
Permissible line length	50 m max.
Supply voltage for 2-wire BERO	22 V to 33 V
<b>Power supply</b>	
Digital section from system bus	5 V, 80 mA typical
<b>Outputs</b>	
Number of outputs	8 min., 16 max., short-circuit protected <sup>1)</sup>
Isolation	Yes
Fusing	6.3 A slow, 1 fuse per 8 outputs
Output voltage for logic 1 for logic 0	L+ - 1.5 V min. 3 V max.
Switching current (resistive, inductive load)	5 mA to 0.5 A
Switching frequency with resistive load with inductive load	120 Hz max. 2 Hz max. at 0.3 A, 0.5 Hz max. at 0.5 A
Breaking voltage (inductive)	Limited to L+ and - 27 V
Total switching current	4 A max. per 8 outputs
Coincidence factor (total load capability) ventilated not ventilated	100 % 50 %, 100 % up to 35 °C
Permissible line length	400 m max.
Current consumption from L+/L-	24 V, 150 mA typical
<b>Short-circuit monitoring</b>	
Indicator for signalling output (H+)	Red LED for every 8 outputs
Output voltage referred to L- (supply of 1L+) for logic 1 for logic 0	1L+ - 5 V min. 3 V max.
Switching current	10 mA max. current limiting
<b>Enable input (F+/F-)</b>	Jumper in front connector
Voltage test to VDE 0160	Between group and ground point: 1250 V AC
<b>Mechanical specifications</b>	
Dimensions (W x H x D)	20 mm x 255 mm x 195 mm
Weight	Approx. 0.4 kg

1) Short-circuit protection responds at line resistance  $\leq 15$  ohms



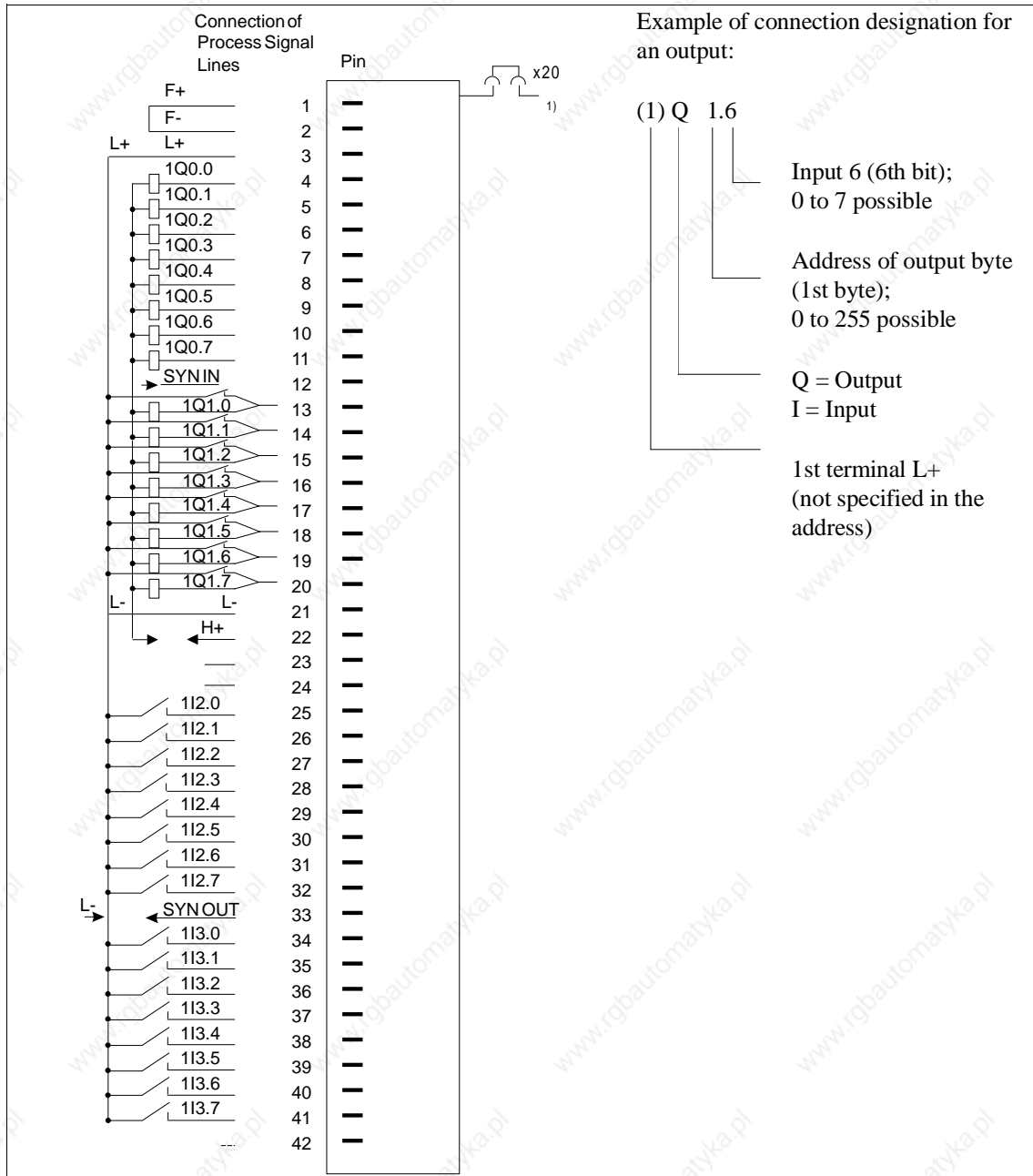

SYSNIN, SYNOUT only relevant for operation with the IP 257

F+/F- = Enable input

- 1) Changeover of enable mode with jumper X20:  
Jumper inserted = Enable input active (factory setting)  
Jumper open = Enable input inactive.

Switch S2 must be at setting 1.



# Analog Input/Output Modules

# 9

## Contents of Chapter 9

9	Analog Input/Output Modules . . . . .	9 - 3
9.1	Technical Description . . . . .	9 - 4
9.2	Common Technical Specifications . . . . .	9 - 5
9.3	The 460 Analog Input Module . . . . .	9 - 6
9.3.1	Design . . . . .	9 - 6
9.3.2	Function of the Enable Input . . . . .	9 - 6
9.3.3	Special Features of the 460 Analog Input Module . . . . .	9 - 10
9.3.4	Setting the Module Address . . . . .	9 - 12
9.3.5	Removing and Inserting Modules . . . . .	9 - 15
9.3.6	Marking of Modules and Front Connectors . . . . .	9 - 17
9.3.7	Connecting the Signal Lines . . . . .	9 - 18
9.3.8	Connection of Sensors . . . . .	9 - 19
9.3.9	Connecting a Compensating Box for Thermal E.M.F. Measurement. . . . .	9 - 21
9.3.10	Connecting Resistance Thermometers in the Standard Pt 100 Range . . . . .	9 - 22
9.3.11	Connecting Resistance Thermometers in the Extended Pt 100 Range. . . . .	9 - 23
9.3.12	Broken Wire Signal . . . . .	9 - 24
9.3.13	Connecting Transducers . . . . .	9 - 25
9.3.14	Measured-Value Representation . . . . .	9 - 26
9.3.15	Technical Specifications . . . . .	9 - 31
9.4	The 463 Analog Input Module . . . . .	9 - 37
9.4.1	Design . . . . .	9 - 37
9.4.2	Function of the Enable Input . . . . .	9 - 37
9.4.3	Special Features of the 463 Analog Input Module . . . . .	9 - 40
9.4.4	Setting the Module Address . . . . .	9 - 41
9.4.5	Removing and Inserting Modules . . . . .	9 - 44
9.4.6	Marking of Modules and Front Connectors . . . . .	9 - 46
9.4.7	Connecting the Signal Lines . . . . .	9 - 47

## Contents

---

9.4.8	Measured-Value Representation . . . . .	9 - 48
9.4.9	Technical Specifications . . . . .	9 - 49
9.5	The 465 Analog Input Module . . . . .	9 - 53
9.5.1	Design . . . . .	9 - 53
9.5.2	Function of the Enable Input . . . . .	9 - 53
9.5.3	Special Features of the 465 Analog Input Module . . . . .	9 - 57
9.5.4	Setting the Module Address . . . . .	9 - 59
9.5.5	Removing and Inserting Modules . . . . .	9 - 62
9.5.6	Marking of Modules and Front Connectors . . . . .	9 - 64
9.5.7	Connecting the Signal Lines . . . . .	9 - 65
9.5.8	Connecting a Compensating Box for Thermal E.M.F. Measurement. . . . .	9 - 66
9.5.9	Connecting Resistance Thermometers to the 465 Analog Input Module . . . . .	9 - 67
9.5.10	Broken Wire Signal for Resistance Thermometers . . . . .	9 - 69
9.5.11	Connecting Transducers . . . . .	9 - 70
9.5.12	Measured-Value Representation . . . . .	9 - 71
9.5.13	Technical Specifications . . . . .	9 - 75
9.6	The 466 Analog Input Module . . . . .	9 - 81
9.6.1	Design . . . . .	9 - 81
9.6.2	Special Features of the 466 Analog Input Module . . . . .	9 - 81
9.6.3	Startup . . . . .	9 - 81
9.6.4	Removing and Inserting Modules . . . . .	9 - 88
9.6.5	Marking of Modules and Front Connectors . . . . .	9 - 90
9.6.6	Connecting the Signal Lines . . . . .	9 - 91
9.6.7	Connecting Sensors to the 466 Analog Input Module . . . . .	9 - 92
9.6.8	Measured-Value Representation . . . . .	9 - 95
9.6.9	Technical Specifications . . . . .	9 - 99
9.7	The 470 Analog Output Module . . . . .	9 - 103
9.7.1	Design . . . . .	9 - 103
9.7.2	Function of the Enable Input . . . . .	9 - 103
9.7.3	Special Features of the 470 Analog Output Module . . . . .	9 - 107
9.7.4	Setting the Module Address . . . . .	9 - 107
9.7.5	Removing and Inserting Modules . . . . .	9 - 110
9.7.6	Marking of Modules and Front Connectors . . . . .	9 - 112
9.7.7	Connecting the Signal Lines . . . . .	9 - 113
9.7.8	Connecting Loads to the 470 Analog Output Module . . . . .	9 - 114
9.7.9	Measured-Value Representation . . . . .	9 - 116
9.7.10	Technical Specifications . . . . .	9 - 117

# Analog Input/Output Modules

# 9

Described in this chapter are the installation, wiring and operation of analog input modules and analog output modules. The individual modules have special features. These are discussed in separate sections.

## 9.1 Technical Description

The description below applies to the following modules:

Analog Input Modules and Cards				
Order No. of the Module	No. of Inputs	Isolation/Groups	Range Card (4 Channels)	Order No. of the Range Card
6ES5 460-4UA13	8	Yes/8 inputs isolated from 0 V and from each other No/none	12.5/50/500 mV/Pt 100	6ES5 498-1AA11
6ES5 465-4UA12	16/8		50/500 mV/Pt 100 ± 1 V ± 10 V ± 20 mA 4 to 20 mA/2-wire trans. ± 5 V 4 to 20 mA/4-wire trans.	6ES5 498-1AA11 6ES5 498-1AA21 6ES5 498-1AA31 6ES5 498-1AA41 6ES5 498-1AA51 6ES5 498-1AA61 6ES5 498-1AA71
Analog Input Modules				
Order No. of the Module	No. of Inputs	Isolation/Groups	Measuring Range	
6ES5 463-4UA12 6ES5 463-4UB12	4	Yes/4 inputs isolated from 0 V and from each other	1 V, 10 V, 20 mA, 4 to 20 mA	
6ES5 466-3LA11	16/8	Yes	1.25 V, 2.5 V, 5 V, 10 V, 20 mA, 4 to 20 mA	
Analog Output Modules				
Order No. of the Module	No. of Outputs	Isolation/Groups	Output Range	
6ES5 470-4UA12	8	Yes/8 outputs from 0 V	± 10 V/0 to 20 mA	
6ES5 470-4UB12	8	Yes/8 outputs from 0 V	± 10 V	
6ES5 470-4UC12	8	Yes/8 outputs from 0 V	± 1 to 5 V/4 to 20 mA	

### I/O modules

Analog input and analog output modules are I/O modules for the input/output of widely differing, analog process signals for the S5-135U/155U programmable (logic) controller.

These I/O modules allow the creation of control systems which require the processing of analog measured variables or continuous input to actuators.

## 9.2 Common Technical Specifications

### Important for the USA and Canada

The following approvals have been obtained for all the modules listed in this chapter:



UL Listing Mark  
Underwriters Laboratories (UL) to  
Standard UL 508, Report E 85972 and E116536 for the  
466-7LA11 analog input module



CSA Certification Mark  
Canadian Standard Association (CSA) to Standard  
C 22.2 No. 142, Report LR 63533C and LR 48323 for  
the 466-7LA11 analog input module

Address range	128 to 255 (0 to 255)
Supply voltage L+ rated value ripple $V_{pp}$ permissible range (including ripple) reference potential	24 V 3.6 V 20 to 30 V $L- = M_{ext} = 0 V$
Voltage for the isolated enable inputs (only required when enable jumper is inserted)	$F+ = + 24 V$ $F- = 0 V$
Line lengths for  Analog input modules with rated input range of $\pm 12 mV$ and $\pm 50 mV$  Analog input modules with rated input range of $\pm 500 mV/\pm 1 V/\pm 5 V/\pm 10 V/\pm 20 mA$ and Pt 100  Analog output modules	50 m max. for shielded cables laid separately from power system cables (see Chapter 3)  200 m max., shielded  200 m max., shielded
Temperature range in operation for storage and transportation	0 to 55 °C - 40 to 70 °C
Relative humidity	95 % max. at 25 °C, no condensation
Site altitude	3500 m max. above sea level
Dimensions (W x H x D)	20 x 255 x 195 mm
Weight	Approx. 0.4 kg

## 9.3 The 460 Analog Input Module

### 9.3.1 Design

The modules are designed as plug-in PCBs for central controllers and expansion units with a backplane connector and with a blade connector to accept a plug-in front connector. You can directly connect the process signal lines to the front connector, which is available separately, with screw or crimp terminals.

#### Addressing switch, mode switches

Situated on each module is an addressing switch with six rockers to set the module address. Analog input modules also have two switches on the side with eight rockers for setting the mode, and receptacles for range cards.

The modules are protected by covers on both sides.

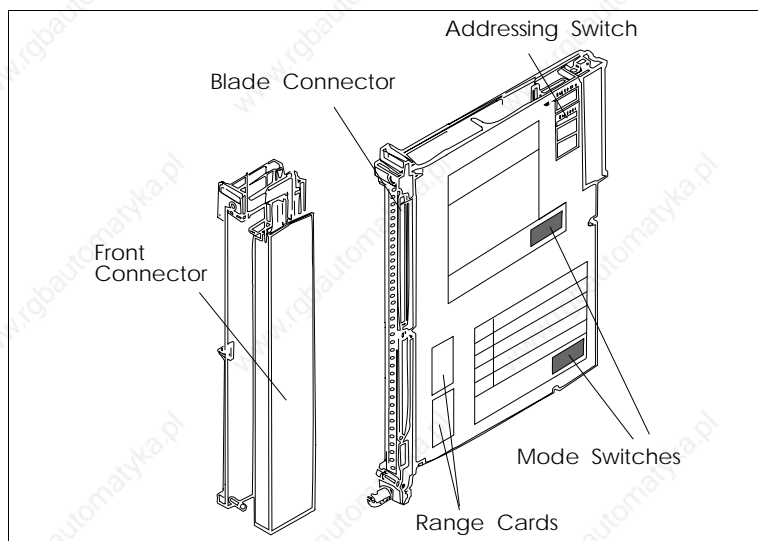

Figure 9-1 Analog Input Module

### 9.3.2 Function of the Enable Input

The 460 module has an enable circuit. You can use the enable inputs to switch off individual modules whilst the PLC is in operation. This means that:

- The module can no longer be addressed by the user program.

Modules which are switched off can be removed or inserted during operation. If this is not necessary, operate the module with the enable input switched off.



**Enable input**

The enable circuit requires an external 24 V voltage at enable inputs F+/F- in the front connector. If there is no voltage at F+/F-, the modules will not acknowledge.

When the front connector is swivelled away from the front strip of the module, the supply of power to the enable input is interrupted, i.e. the module is switched off and can no longer be addressed by the user program: a timeout (QVZ) occurs in the CC.

**Switching off the enable input**

The 460 module additionally offers the facility for changing the enable mode. The module has a jumper accessible from above in the vicinity of the addressing switch.

When the enable jumper is inserted, you can define the behaviour of the 460 analog input module as follows:

- When the enable voltage and load voltage are obtained from the same load supply, a shutdown of the 24 V load voltage will result in a timeout.
- When the enable voltage and load voltage are obtained from different load supplies, a shutdown of the 24 V load voltage will not result in a timeout. (With the 460-4UA11/12 modules, a shutdown of the load voltage will result in a timeout.)

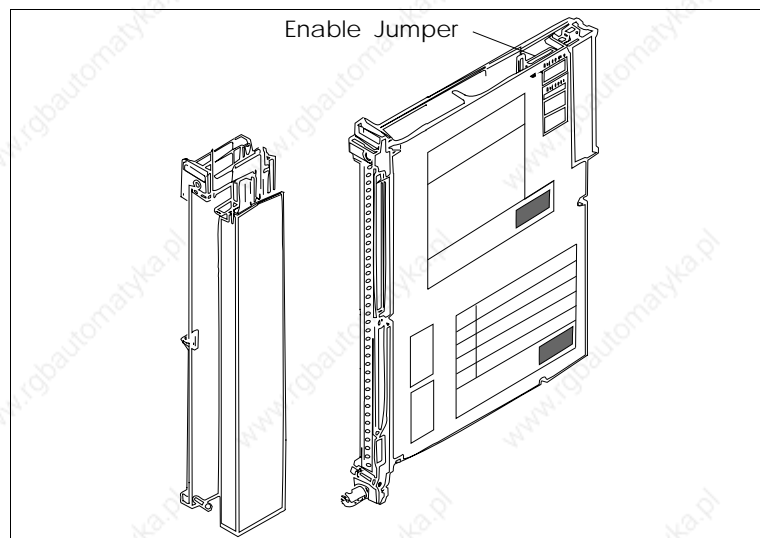

Figure 9-2 Enable Input and Enable Jumper

Jumper inserted: Enable input (F+/F-) active (factory setting)

Jumper open: Enable input (F+/F-) switched off

Examples of functioning of the enable inputs:

- To switch off individual subprocesses, i.e. outputs of various modules can be operated from a common load supply and yet activated separately.
- The load voltage of individual modules can be monitored without additional circuitry. Any reactions to failure of the load voltage can be programmed in the QVZ (timeout) organization block.

**Configuring**

You must observe the following when configuring systems:

Switching on	At the latest 100 ms after power-up of the PLC, the voltage must be present at the enable inputs of the I/O modules.
Switching off	When the PLC has been switched off, the voltage at the enable inputs of the I/O modules must still be present as long as the internal 5 V voltage is present.

**Switching off the CC**

You should observe the following instructions for switching off CCs and equipment for supplying power to the enable inputs.

**Separate or common shutdown of the CC/EU and load power supply**

When there is a need to switch off the load power supply separately without affecting the enabling of modules, there are the following possibilities for producing the enable voltage. These exist even when the load power supply is used without an additional capacitor and common shutdown.

- **230 V AC supply for CC/EU and load power supply**

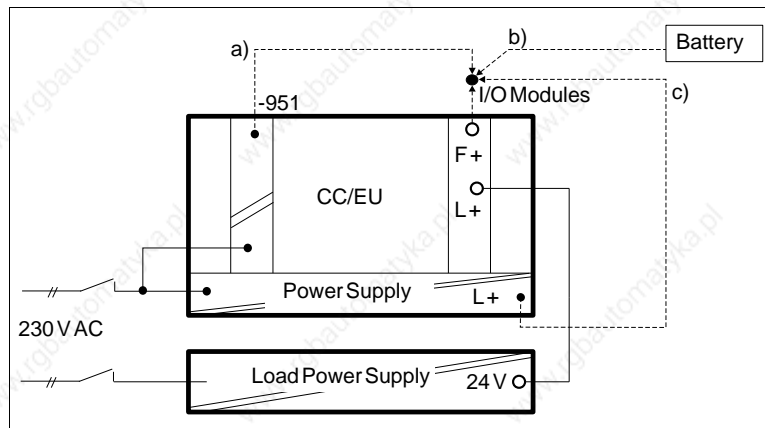

Supply for the enable inputs from:

- 6ES5 951-4LB11 load power supply
- Battery
- Terminals for 24 V on the front plate of the power supply

- 24 V supply for CC/EU and I/Os

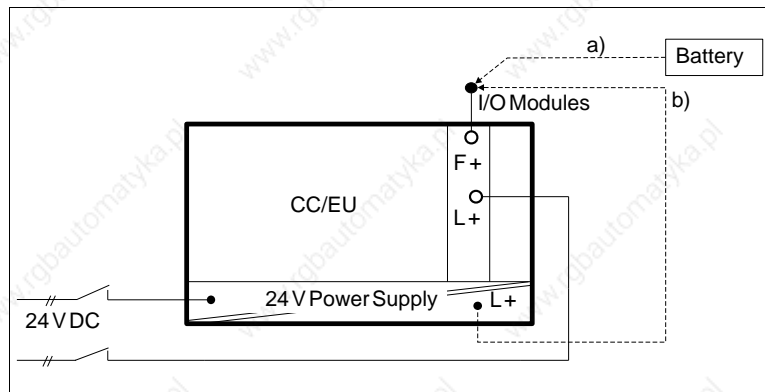

Supply for the enable inputs from:

- a) Battery
- b) Terminals for 24 V on the front plate of the power supply

*Common shutdown of the CC/EU and load power supply with a 230 V AC supply*

Proper functioning is ensured if the 24 V load power supply has an output capacitance of at least 4700  $\mu\text{F}$  per 10 A of load current. Other units which do not meet this condition can be adapted to this requirement by connecting a 10000  $\mu\text{F}/40\text{ V}$  capacitor in parallel.

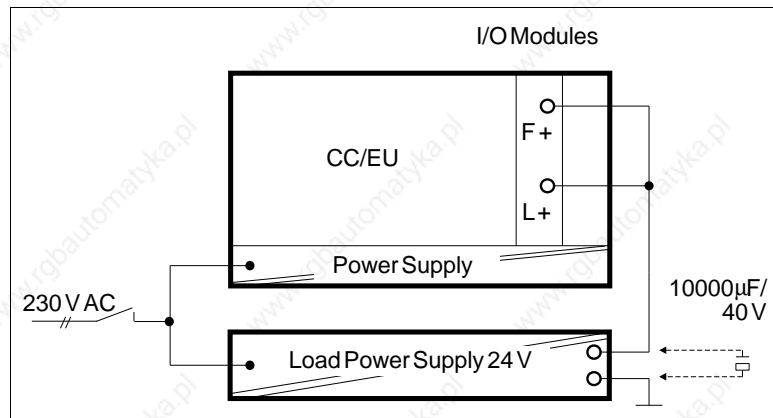

### 9.3.3

#### **Special Features of the 460 Analog Input Module**

The 460 analog input module executes integrating processing of the digital input signals; periodic system interference is thus suppressed.

You can adapt the process signals, according to the application, to the input level of the analog-to-digital converter of the module with plug-in range cards (resistor dividers or shunt resistors).

#### *Broken wire signal*

To monitor the sensors connected to the inputs, you can use the 6ES5 498-1AA11 range card (through-connection card) to implement the "broken wire detection" mode. You can activate broken wire detection for 4 or 8 inputs.

Each time the input value is about to be encoded, a constant current is briefly (1.6 ms) switched to the input terminals and the resultant current is checked for a limit value. If a digital voltmeter is used to measure the signal at the input, these current pulses may appear to indicate fluctuation of the signal. The encoded value, however, is not affected.

#### *Switching the tripping current to the inactive state*

If these apparent fluctuations of the signal are disturbing, e.g. during startup, you can switch the tripping current to the inactive state on the 460 analog input module: apply + 24 V to pin 24 of the front connector, and 0 V to L-. You must additionally set the mode switch to "without broken wire detection".

In the event of open-circuit of the sensor or its line, the voltage exceeds the limit and a broken wire is indicated (bit 1 in data byte 1). The analog-to-digital converter encodes the value 0.

A broken wire signal is only useful when the 6ES5 498-1AA11 through-connection card is used. With all other measurement cards, a broken wire signal will result in incorrect reactions. Further details relating to the broken wire signal can be found in Section 9.3.12.

#### *Measuring range exceeded*

If the measuring range is exceeded, the overflow bit (bit 2<sup>0</sup> of the low byte) is set.

#### *Cyclic sampling*

You have a choice of the cyclic sampling and selective sampling modes.

In the cyclic sampling mode, the module continuously encodes all measured values. The digitized measured values are stored under the channel-related address on the module (the high byte under this address, and the low byte under the next higher address). The measured values can then be read by the module at any time without waiting. When you operate the module in this mode, you can set a module address from 0 to 255.

**Selective sampling**

In the selective sampling mode, a measured value is encoded on the central initiative of the CPU. At the start of conversion, the module must be addressed once with a write operation (T PW) by the user program. An active bit (T = 1) is set during encoding.

With the transition to T = 0, the measured value becomes valid. With non-constant cycle times, there may be non-periodic measured value acquisition. If you operate the module in this mode, you must set a module address from 128 to 255. You can also use the address range from 0 to 127 for selective sampling after appropriate programming in DB 1 of the user program.

**Time-controlled program processing**

Another method is that of time-controlled program processing. With this method, certain program segments (e.g. FB 13) are automatically inserted into program processing at the 100 ms rate by a time-controlled block (OB 13). A constant timebase is thus achieved.

```

FB 13          SPM-B          LEN=22      ABS
                                           SHEET 1

SEGMENT 1
NAME: SELSAMPL          EXAMPLE OF SELECTIVE SAMPLING

0005          :
0006          :
0007          :L   PW 128    READ ANALOG VALUE
0008          :T   FW 128    IN TO AUX: FLAG FW 128
0009          :A   F 129.2   SCAN ACTIVITY =1?
000A          :JC   = END    IF = 1, JUMP TO END
000B          :T   FW 10     IF = 0, MEASURED VALUE IN FW 10
000C          :T   PB 128    INITIATE SAMPLING
000D  END    :              (1ST VALUE INVALID AFTER START)
000E          :
000F          :
0010          :BE
    
```

**Function block**

You can read analog values of analog input modules with a function block from the "basic functions" package.

**BASP (output inhibit)**

The BASP signal is not interpreted by the 460 analog input module.

### 9.3.4

#### Setting the Module Address

You set the module address on the addressing switch. This also establishes the necessary assignments between user program and process connection. The module address is the sum of the decimal significances of the switch rockers in the On setting (●).

One data word = two data bytes is required to process an input or an output. A module with 16 inputs therefore reserves 32 byte addresses, and a module with 8 inputs or outputs reserves 16 byte addresses.

#### Labelling field

You can affix the adhesive label with the desired module address on a free labelling field under the addressing switch.

The switch rockers to be set for the module address specified as a decimal number (address bit ADB) are marked by dots on the label.

Press the individual rockers of the addressing switch downwards with a ballpoint pen or similar object, but not a pencil.

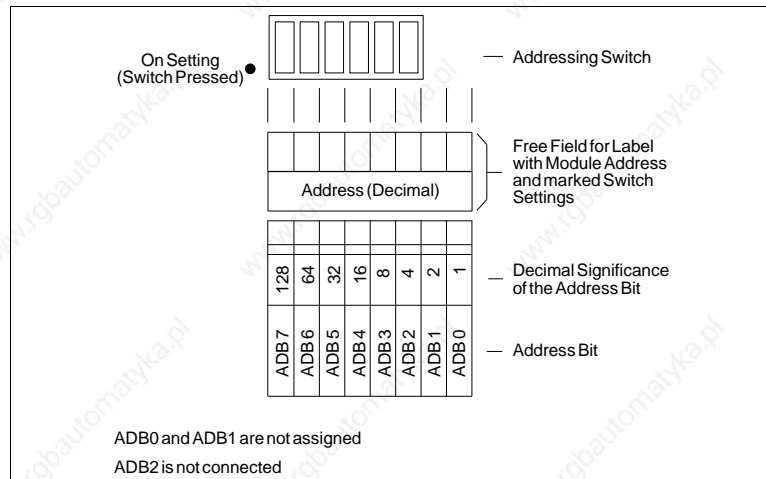

Figure 9-3 Labelling of the Addressing Switch

The address under which the module is referenced by the STEP 5 program is independent of the slot.

#### Start address, subaddress

For analog input and analog output modules (8 inputs) only the lowest address (start address) is set. Other addresses (subaddresses) are decoded on the module.

**Note**

The start address of the analog module must be a multiple of the double channel number.

4 channels : 0, 8, 16, 24, ... 248

8 channels : 0, 16, 32, 48, ... 240

If one of the inputs or outputs (Channel 0 to 7) of a module is to be addressed, the relevant subaddress must be specified in the program.

The subaddress of the input or output, based on the start address of the module, is given by:

$$\text{Start address} + 2 \times \text{channel no.} = \text{subaddress}$$

**Example:**

Analog input module with 8 inputs

The address is the sum of the significances set with the individual coding switches.

$$160 = 128 + 32 = 2^7 + 2^5$$

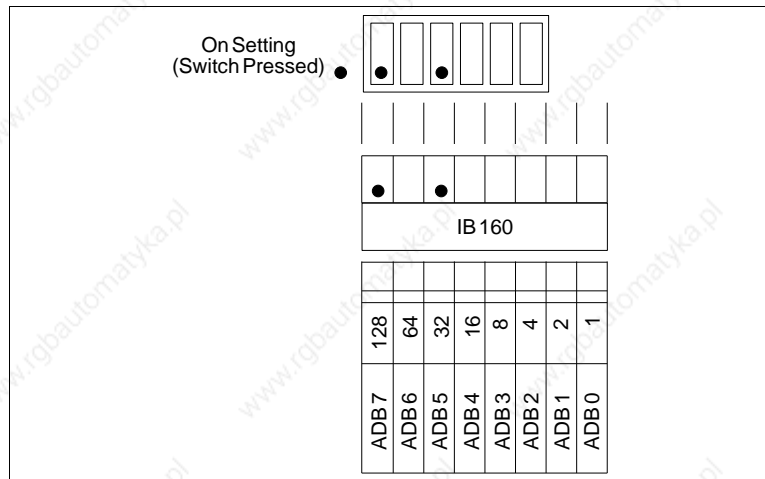

A module with 8 inputs (Channel 0 to 7) and start address 160 reserves the address range from

$$160 \text{ to address } 160 + 7 \times 2 = 174$$

In this example, the next free address for another module is 176.

Addresses already assigned must not be set again.

**Addressing for cyclic/selective sampling**

However, analog input modules and analog output modules may be given the same address with cyclic sampling because they are distinguished by the user program. This is not possible with selective sampling.

For cyclic sampling, you can address the module in the address range from 0 to 255, and for selective sampling from 128 to 255. For selective sampling, you can also use the address range from 0 to 127 after appropriate programming in DB 1 of the user program.

**Example:**

On an analog input module with start address 160 (IB 160 = input byte 160), input channel 3 is to be scanned by the program.

Step	Action
1	Affix the self-adhesive label with address 160 on the free field under the addressing switch on the module. ADB 5 and ADB 7 are marked on the label.
2	Press the appropriate rockers of the addressing switch down on the side marked by a dot on the module cover. Set the other rockers to the opposite setting. This way sets the start address of the module. ADB 5 and ADB 7 results in $2^5 + 2^7 = 32 + 128 = 160$
3	Enter the address $160 + 3 \times 2 = 166$ in the program for input channel 3.



### 9.3.5 Removing and Inserting Modules



#### Warning

When removing and inserting the front connector during operation, hazardous voltages of more than 25 V AC or 60 V DC may be present at the module pins. When this is the case at the front connector, live modules may only be replaced by electrical specialists or trained personnel in such a way that the module pins are not touched.

During operation, the front connector and module must not be removed or inserted without the enable jumper or active enable circuit.

Install an analog input/output module as follows:

Step	Action
1	Release the upper locking bar on the subrack and swivel it upwards and out.
2	Insert the module at the desired slot in the subrack and push it back in the guides.
3	Latch the module by rotating the locking pin by 90° at the lower end of the module. It must no longer be possible to pull the module forwards.
4	Engage the front connector on the support pin of the module. The width of the support pin also provides keying to prevent front connectors from being fitted to the wrong modules (e.g. front connectors with 115/230 V AC wiring cannot be plugged into analog modules).
5	Tighten the screw in the upper part of the front connector.

Remove an analog input/output module as follows:

Step	Action
1	Release the upper locking bar on the subrack and swivel it upwards and out.
2	Slacken the screw in the upper part of the front connector. This causes the front connector to be pressed out of the female connector of the module. Contacts F+ and F- of the enable input at the upper end of the front connector are thus opened first. If the enable input is active, power is removed from the outputs and the module is isolated from the S5 bus.
3	Swing the front connector out and lift it away from the support pin of the module.
4	Release the module by rotating the locking pin by 90° at the lower end of the module. You can pull the module out of the subrack with a grip with swivels outwards.

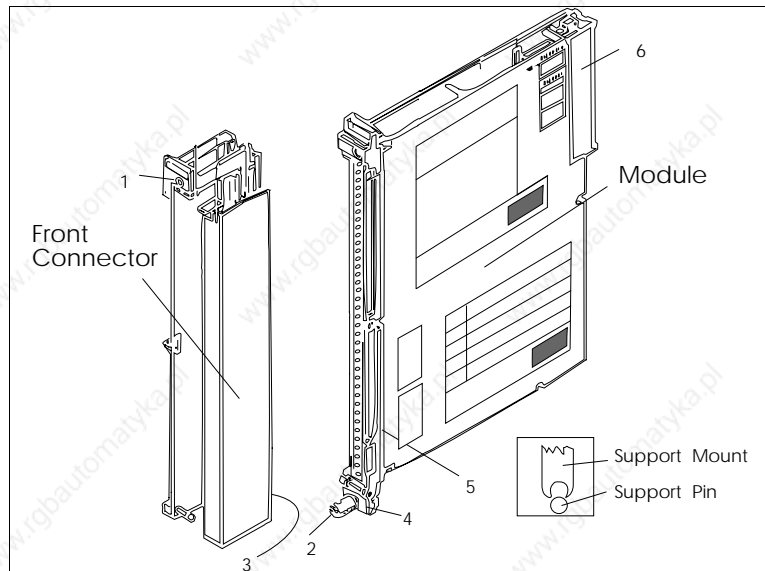

Figure 9-4 Module with Front Connector

- 1 Screw
- 2 Locking pin
- 3 Support mount
- 4 Support pin
- 5 Grip
- 6 Backplane connector

Comply with VDE Specifications 0110 and 0160 to carry out the wiring of supply and signal lines which are to be connected to the programmable controllers and front connectors of the modules.

Detailed information on cabinet assembly, cabinet ventilation and protective measures can be found in Chapter 3.

### 9.3.6 Marking of Modules and Front Connectors

For the marking of modules and front connectors, labels are supplied with the module and central controller; they are affixed as shown in Figure 9-5.

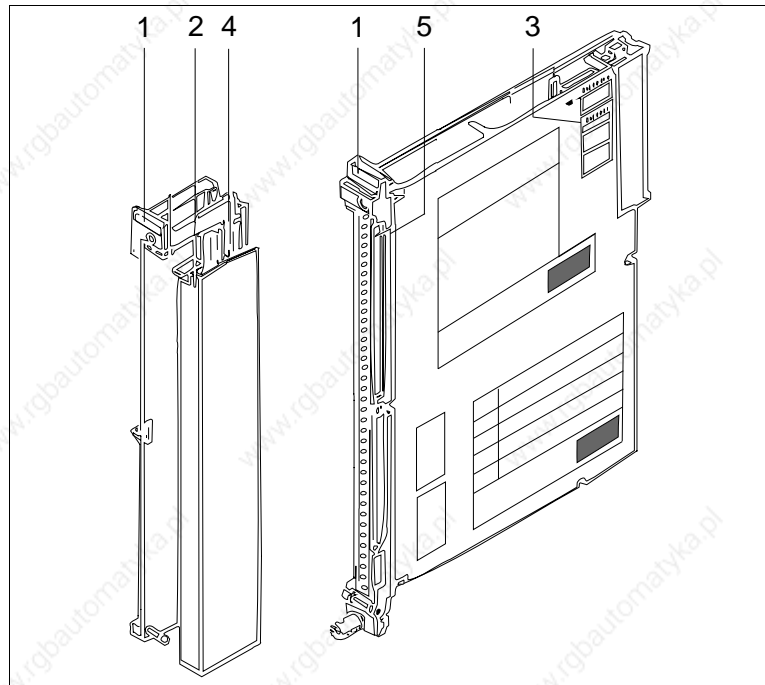

Figure 9-5 Marking and Labelling of Modules

- 1 Label with the module address under which the module is referenced by the STEP 5 program
- 2 Labelling strip with the product designation for the module; space to mark the module version and label the channels
- 3 Label with module address and marking of the required settings for the addressing switch
- 4 Labelling strip for terminal designations or connection diagrams (strip in the cover of the front connector)
- 5 Name plate

### 9.3.7

#### Connecting the Signal Lines

For connection of the signal lines, front connectors for 20 and 40 mm mounting width with crimp connection and 40 mm mounting width with screw connection are available (screwdriver blade width: 3.5 mm, maximum torque: 0.8 Nm).

Use stranded conductor to facilitate handling of the front connector. Ferrules are not required for screw connections, because the screw terminals are provided with wire protection.

When the crimp contact is inserted in the plastic body of the front connector, a click can clearly be heard. This indicates that the contact is engaged. For jumpering or to correct the wiring, you can remove the contacts with a releasing tool (see ordering information) without having to pull out the front connector.

Ferrules are not required for screw connections, because the screw terminals are provided with wire protection. You can use ferrules of 7 mm in length to DIN 46228. The maximum terminal area is  $2 \times 2.5 \text{ mm}^2$ .

Terminal Type	Connector Type 6ES 497-	Max. No. of Contacts	Cross-Section		Connector for Rated Voltage	Mounting Width of Module
			Signal or Supply Conductor	Aux. Jumper in Connector <sup>1)</sup>		
Crimp connection	-4UA12 <sup>2)</sup>	42	0.5 mm <sup>2</sup>	0.5 mm <sup>2</sup>	5 to 60 V DC	20 mm Operation with fan
	-4UA22 <sup>2)</sup>	42	0.5 mm <sup>2</sup>	0.5 mm <sup>2</sup>	5 to 60 V DC	40 mm
Screw connection	-4UB12	42	0.5 to 2.5 mm <sup>2</sup>	0.5 to 1.0 mm <sup>2</sup>	5 to 60 V DC	40 mm Operation without fan
	-4UB31	42	0.5 to 1.5 mm <sup>2</sup>	0.5 to 1.0 mm <sup>2</sup>	5 to 60 V DC	20 mm

<sup>1)</sup> To multiply the supply and 0 V ground terminals, and to connect the enable input

<sup>2)</sup> The crimp contacts must be ordered separately for these types of connector.



#### Caution

Only extra-low voltage 60 V DC with safety separation from system voltage may be used for the 24 V DC supply and for the 24 V DC input signals. Safety separation can be implemented to the requirements of, amongst other sources, VDE 0100 Part 410/HD 384-4-41/IEC 364-4-41 (as functional extra-low voltage with safety separation) or VDE 0805/EN 60950/IEC 950 (as safety extra-low voltage SELV) or VDE 0106 Part 101.

**9.3.8 Connection of Sensors**

Observe the following information when connecting the sensors.

*Connection of current or voltage sensors*

With isolated sensors, it is possible for the measuring circuit to develop a potential with respect to ground which exceeds the permissible potential difference  $U_{CM}$  (see maximum values of the individual modules). To prevent this, you must connect the negative potential of the sensor to the reference potential of the module (0 V bus).

**Example:**

Temperature measurement on a busbar with insulated thermocouples

*Equipotential bonding*

In the worst case, the measuring circuit can develop an excessively high potential on account of a static charge or contact resistances. This must be prevented with an equipotential bonding conductor.

The permissible potential difference ( $U_{CM}$ ) between the inputs and the 0 V bus must not be exceeded.

Depending on the system or type of sensor, the potential difference must be kept in the permissible region with equipotential bonding.

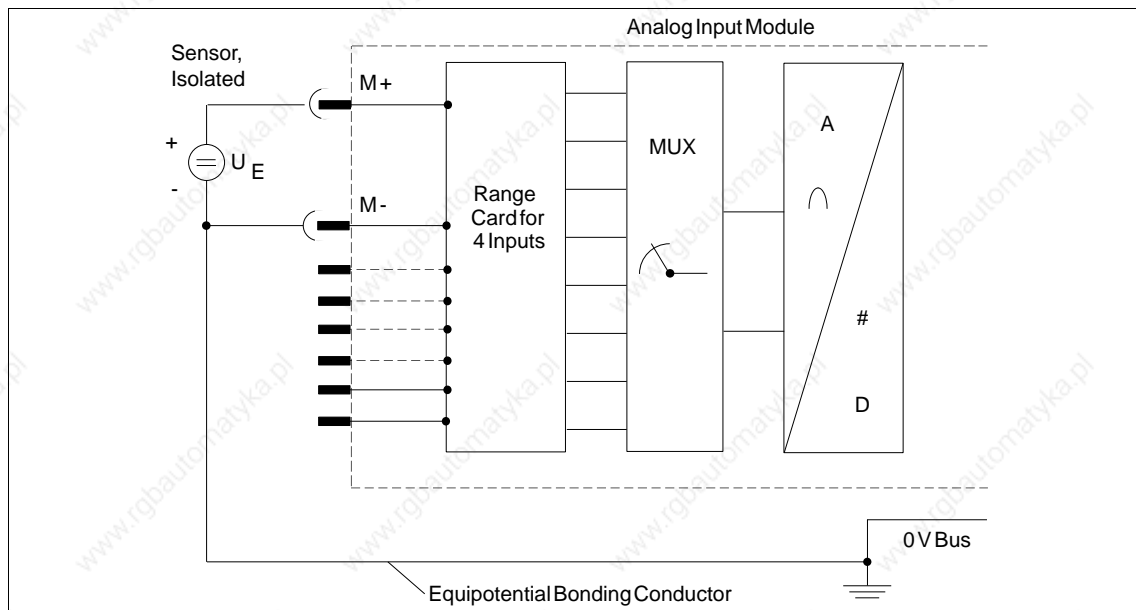

Figure 9-6 Measuring Circuit with Equipotential Bonding Conductor for the 460 Analog Input Module

**Example:**

(Special case) The temperature of the busbar of an electroplating bath is to be measured with an **uninsulated** thermocouple.

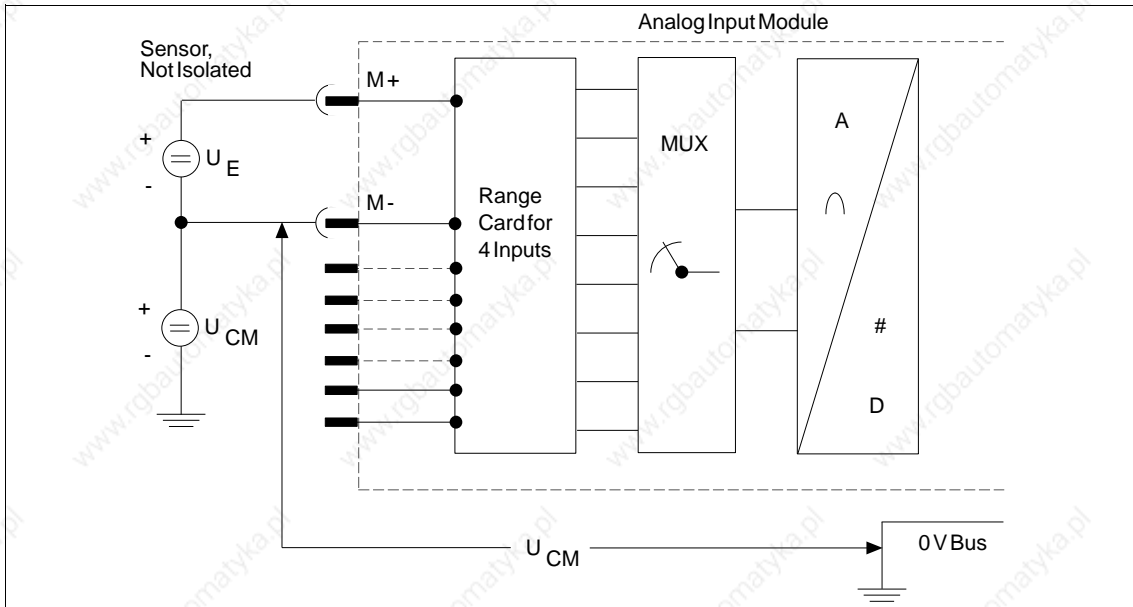

Figure 9-7 Measuring Circuit without Equipotential Bonding Conductor for the 460 Analog Input Module

The potential of the busbar with respect to the reference potential of the module is, for example, 24 V DC. A 460 analog input module with isolated input is used ( $U_{CM} = 60 \text{ V AC}/75 \text{ V DC}$ ). An equipotential bonding conductor must not be laid here because it would short-circuit the busbar.

### 9.3.9 Connecting a Compensating Box for Thermal E.M.F. Measurement

If the room temperature fluctuations at the reference point (e.g. in the terminal box) affect the measurement result and you do not wish to use a thermostat, you can compensate for the effect of temperature on the reference point with a compensating box. Between  $-10$  and  $+70$  °C, it compensates for the change in thermal e.m.f. cause by temperature deviation (compensating box, see Catalog MP 11). Ensure that the compensating box has thermal contact with the terminals.

If the compensating box is aligned at  $20$  °C, this must be taken into account in temperature evaluation ( $20$  °C measuring point temperature =  $0$  mV).

Pins 22 and 23 are extended on analog input modules as an input for the compensating voltage. You must select a common input loop for all inputs on mode switch 2.

The compensating box must be connected in a floating circuit. The power supply unit of the compensating box must have a grounded shield winding to avoid AC system interference being picked up. A separate compensating box with its special power supply unit is required for each analog input module.

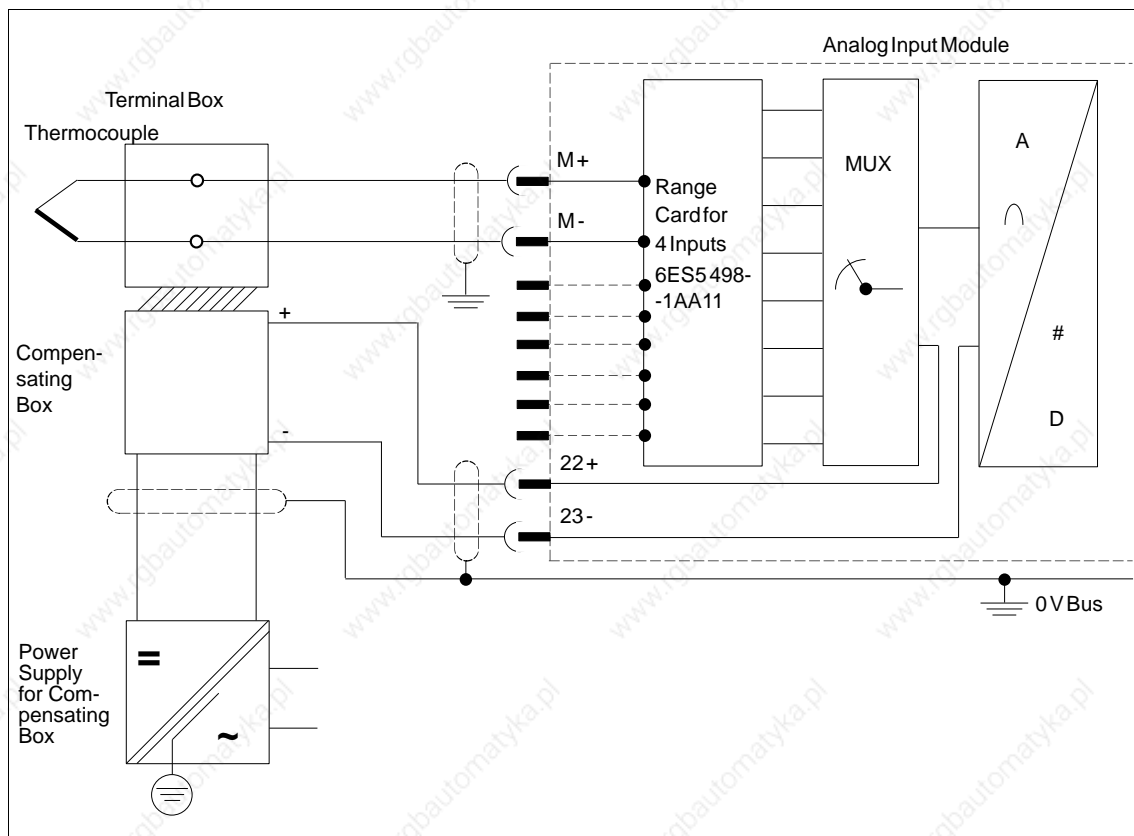

Figure 9-8 Connecting a Compensating Box

**9.3.10  
Connecting Resistance  
Thermometers in the  
Standard Pt 100 Range**

The series-connected resistance thermometers (up to 8 Pt 100s) are fed with a current of 2.5 mA ( $I_{C+}/I_{C-}$ ) by a constant current generator. The voltage at the Pt 100's is picked off at measurement inputs M+ and M-. In this mode, the whole temperature range of the Pt 100 (-200 °C to +840 °C) is available. The mode is printed on the cover of the module as follows:

"resistance thermometer uncompensated full range".

Other voltage sensors can be connected in a floating circuit at the M+/M- inputs of a card which are not assigned to resistance thermometers (voltage range 500 mV).

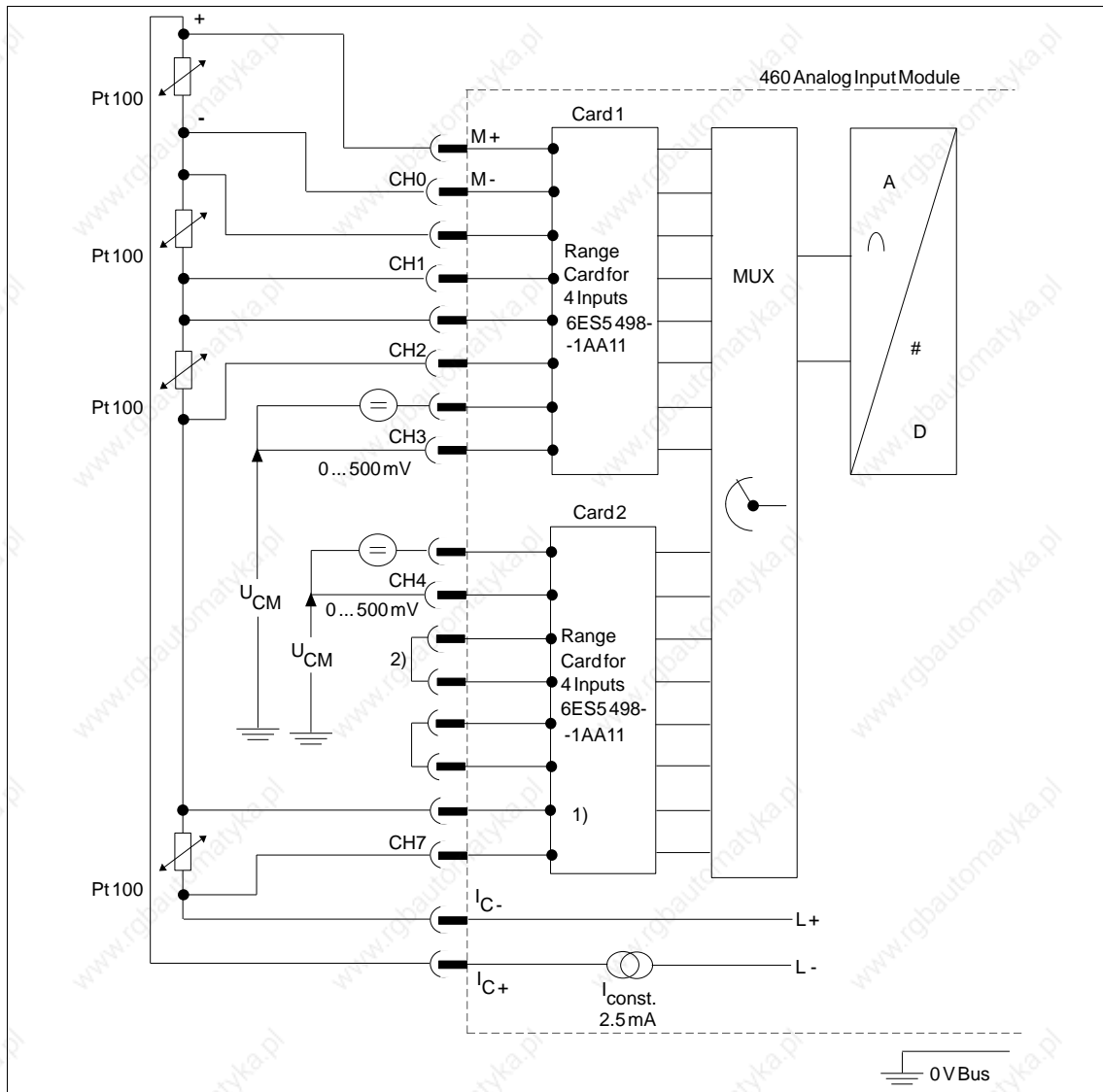

Figure 9-9 Connecting Resistance Thermometers in the Standard Pt 100 Range

- 1) If no Pt 100 is connected to CH4 to CH7, other voltages and currents can be measured at these channels with cards 6ES5 498-1AA21, 6ES5 498-1AA31, 6ES5 498-1AA41, 6ES5 498-1AA51, 6ES5 498-1AA61, 6ES5 498-1AA71.
- 2) When cards 6ES5 498-1AA41, 6ES5 498-1AA51 or 6ES5 498-1AA71 are used, a short-circuit jumper is not required.



**9.3.11  
Connecting Resistance  
Thermometers in the  
Extended Pt 100 Range**

The series-connected resistance thermometers (up to 8 Pt 100s) are fed with a current of 2.5 mA ( $I_{C+}/I_{C-}$ ) by a constant current generator. The voltage at the Pt 100s is picked off at measurement inputs M+ and M-.

In this mode, the temperature range of approximately -100 °C to +100 °C has a more accurate resolution. The mode is printed on the cover of the module as follows:

"resistance thermometer compensated low range".

You should only use the 6ES5 498-1AA11 range card ( $\pm 50$  mV / 500 mV).

Unused inputs must be connected in parallel to a wired input. In the following figure, for example, these are the inputs CH4 to CH7.

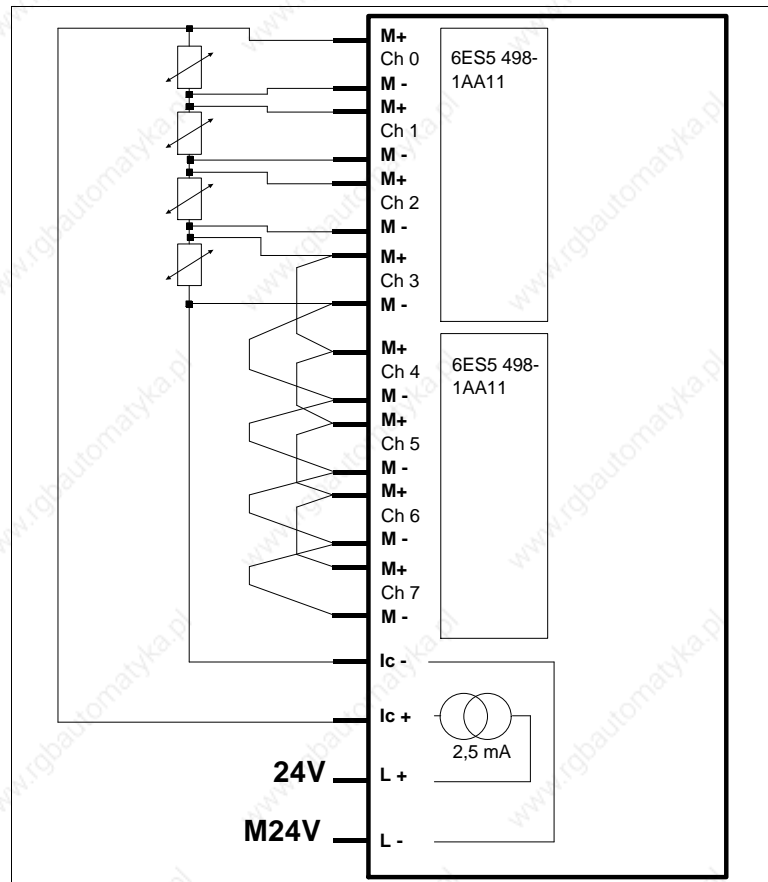

Figure 9-10 Connecting Resistance Thermometers in the Extended Pt 100 Range

### 9.3.12 Broken Wire Signal

*Broken wire signal in the standard Pt 100 range*

An open-circuit in the lines to a resistance thermometer is indicated as follows:

Broken Wire at	Module Reaction, Encoded Value	Error Bit E
M+	0	1
M-	0	1
Pt 100	0 <sup>1)</sup>	1
IC+	0	0
IC-	0	0

<sup>1)</sup> With the 460 analog input module, the value 0 is also encoded for the intact Pt 100 resistances because the auxiliary circuit is interrupted; the error bit will not be set for these channels.

If the mode "without broken wire signal" is selected on the module, an open-circuit of the resistance thermometer is indicated with an overflow.

Unassigned channels can be used for voltage or current measurement.

*Broken wire signal in the extended Pt 100 range*

If a line of the auxiliary circuit (IC+, IC-) is interrupted, the "negative range limit" is encoded for all inputs and the overflow bit is set to "1". In the event of a sensor or measuring line open-circuit, the error bit is additionally set to "1" for the relevant channel.

**9.3.13**  
**Connecting Transducers**

Two-wire transducer (short-circuit protected supply voltage via the range card of the analog input module)

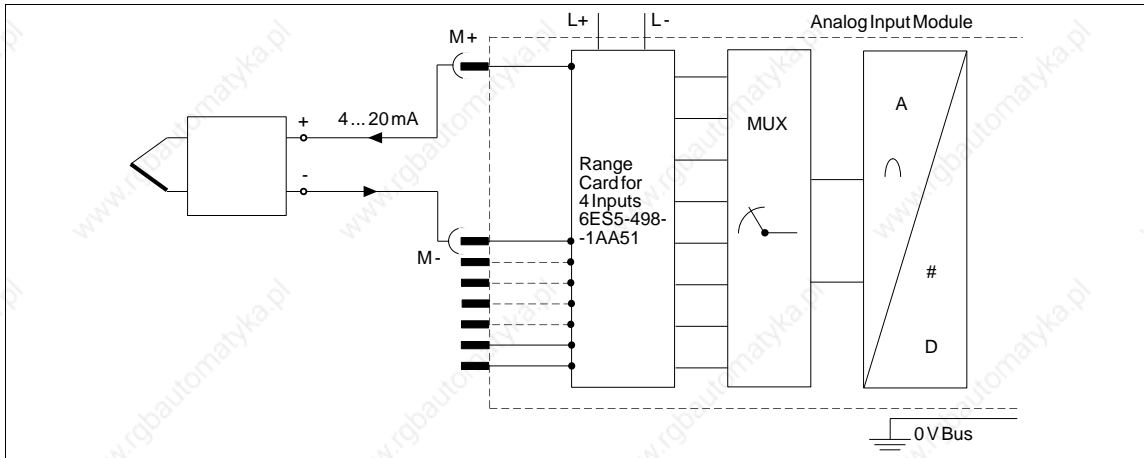

Four-wire transducer (with separate supply voltage)

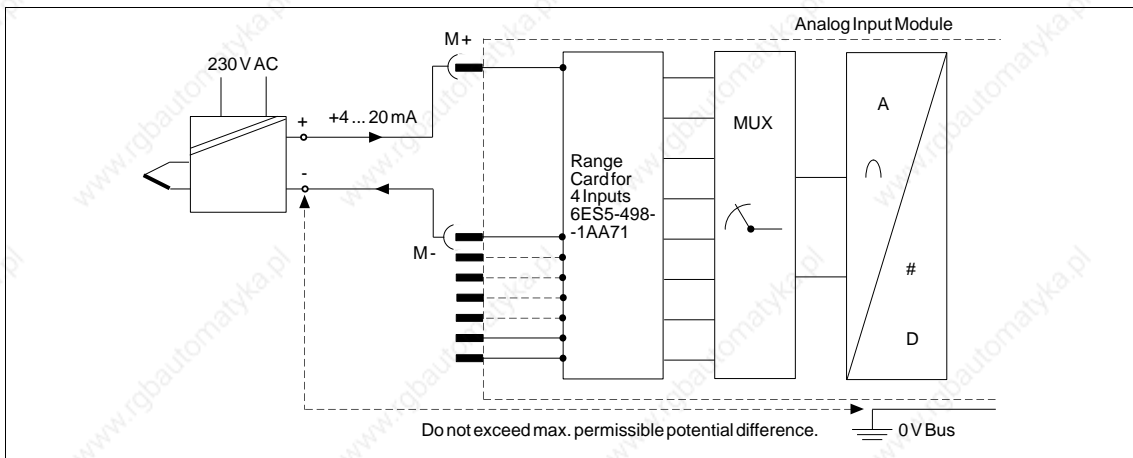

9

Four-wire transducer with a two-wire transducer card

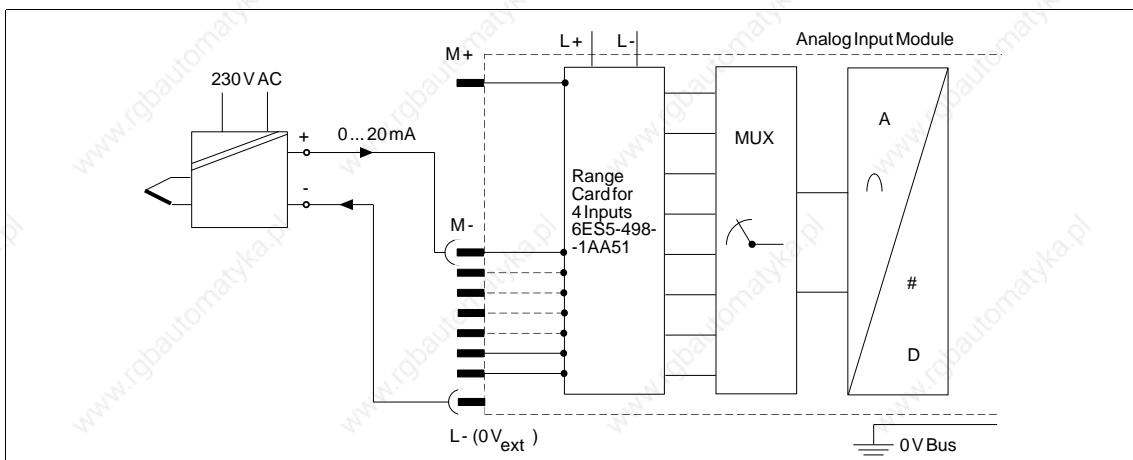

### 9.3.14 Measured-Value Representation

*Digital measured-value  
representation as two's  
complement* (rated input range  $\pm 50$  mV)

Units	Input Voltage in mV	Byte 0								Byte 1								
		7 2 <sup>12</sup>	6 2 <sup>11</sup>	5 2 <sup>10</sup>	4 2 <sup>9</sup>	3 2 <sup>8</sup>	2 2 <sup>7</sup>	1 2 <sup>6</sup>	0 2 <sup>5</sup>	7 2 <sup>4</sup>	6 2 <sup>3</sup>	5 2 <sup>2</sup>	4 2 <sup>1</sup>	3 2 <sup>0</sup>	2 A	1 E	0 OV	
$\geq 4096$	100.0	0	1	1	1	1	1	1	1	1	1	1	1	1	0/1	0/1	1	Overflow
4095	99.976	0	1	1	1	1	1	1	1	1	1	1	1	1	0/1	0/1	0	Overrange
2049	50.024	0	1	0	0	0	0	0	0	0	0	0	0	1	0/1	0/1	0	
2048	50.0	0	1	0	0	0	0	0	0	0	0	0	0	0	0/1	0/1	0	
2047	49.976	0	0	1	1	1	1	1	1	1	1	1	1	1	0/1	0/1	0	
1024	25.0	0	0	1	0	0	0	0	0	0	0	0	0	0	0/1	0/1	0	
1023	23.976	0	0	0	1	1	1	1	1	1	1	1	1	1	0/1	0/1	0	
1	0.024	0	0	0	0	0	0	0	0	0	0	0	0	1	0/1	0/1	0	
0	0.0	0	0	0	0	0	0	0	0	0	0	0	0	0	0/1	0/1	0	Rated range
-1	-0.024	1	1	1	1	1	1	1	1	1	1	1	1	1	0/1	0/1	0	
-1023	-24.976	1	1	1	0	0	0	0	0	0	0	0	0	1	0/1	0/1	0	
-1024	-25.0	1	1	1	0	0	0	0	0	0	0	0	0	0	0/1	0/1	0	
-2047	-49.976	1	1	0	0	0	0	0	0	0	0	0	0	1	0/1	0/1	0	
-2048	-50.0	1	1	0	0	0	0	0	0	0	0	0	0	0	0/1	0/1	0	
-2049	-50.024	1	0	1	1	1	1	1	1	1	1	1	1	1	0/1	0/1	0	Overrange
-4095	-99.976	1	0	0	0	0	0	0	0	0	0	0	0	1	0/1	0/1	0	
-4096	-100.0	1	0	0	0	0	0	0	0	0	0	0	0	1	0/1	0/1	1	Overflow

A = Active bit  
E = Error bit  
OV = Overflow bit

Digital measured-value representation as value and sign (rated input range  $\pm 50$  mV)

Units	Input Voltage in mV	Byte 0								Byte 1								
		7 S	6 $2^{11}$	5 $2^{10}$	4 $2^9$	3 $2^8$	2 $2^7$	1 $2^6$	0 $2^5$	7 $2^4$	6 $2^3$	5 $2^2$	4 $2^1$	3 $2^0$	2 A	1 E	0 OV	
$\geq 4096$	100.0	0	1	1	1	1	1	1	1	1	1	1	1	1	0/1	0/1	1	Overflow
4095	99.976	0	1	1	1	1	1	1	1	1	1	1	1	1	0/1	0/1	0	Overrange
2049	50.024	0	1	0	0	0	0	0	0	0	0	0	0	1	0/1	0/1	0	
2048	50.0	0	1	0	0	0	0	0	0	0	0	0	0	0	0/1	0/1	0	Rated range
2047	49.976	0	0	1	1	1	1	1	1	1	1	1	1	1	0/1	0/1	0	
1024	25.0	0	0	1	0	0	0	0	0	0	0	0	0	0	0/1	0/1	0	
1023	23.976	0	0	0	1	1	1	1	1	1	1	1	1	1	0/1	0/1	0	
1	0.024	0	0	0	0	0	0	0	0	0	0	0	0	1	0/1	0/1	0	
0	0.0	0	0	0	0	0	0	0	0	0	0	0	0	0	0/1	0/1	0	
-0	0.0	1	0	0	0	0	0	0	0	0	0	0	0	0	0/1	0/1	0	
-1	-0.024	1	0	0	0	0	0	0	0	0	0	0	0	1	0/1	0/1	0	
-1023	-24.976	1	0	0	1	1	1	1	1	1	1	1	1	1	0/1	0/1	0	
-1024	-25.0	1	0	1	0	0	0	0	0	0	0	0	0	0	0/1	0/1	0	
-2047	-49.976	1	0	1	1	1	1	1	1	1	1	1	1	1	0/1	0/1	0	
-2048	-50.0	1	1	0	0	0	0	0	0	0	0	0	0	0	0/1	0/1	0	
-2049	-50.024	1	1	0	0	0	0	0	0	0	0	0	0	1	0/1	0/1	0	Overrange
-4095	-99.976	1	1	1	1	1	1	1	1	1	1	1	1	1	0/1	0/1	0	Overrange
-4096	-100.0	1	1	1	1	1	1	1	1	1	1	1	1	1	0/1	0/1	1	

A = Active bit  
 E = Error bit  
 OV = Overflow bit  
 S = Sign bit

Bit  $2^{12}$  is interpreted as the sign.

**Measured-value representation for resistance thermometers in the standard Pt 100 range**

The resolution with Pt 100 resistance thermometers is approximately 0.25 °C.  
1 ohm ≡ 10 units

Inputs	Resistance in Ohms	Temperature in °C	Byte 0								Byte 1								
			7 S	6 2 <sup>11</sup>	5 2 <sup>10</sup>	4 2 <sup>9</sup>	3 2 <sup>8</sup>	2 2 <sup>7</sup>	1 2 <sup>6</sup>	0 2 <sup>5</sup>	7 2 <sup>4</sup>	6 2 <sup>3</sup>	5 2 <sup>2</sup>	4 2 <sup>1</sup>	3 2 <sup>0</sup>	2 A	1 E	0 OV	
4096	400.0	-	0	1	1	1	1	1	1	1	1	1	1	1	1	0/1	0/1	1	Overflow
4095	399.90	-	0	1	1	1	1	1	1	1	1	1	1	1	1	0/1	0/1	0	Overrange
2049	200.098	69.1	0	1	0	0	0	0	0	0	0	0	0	0	1	0/1	0/1	0	
2048	200.0	66.5	0	1	0	0	0	0	0	0	0	0	0	0	0	0/1	0/1	0	
2047	199.90	66.0	0	0	1	1	1	1	1	1	1	1	1	1	1	0/1	0/1	0	
1024	100.00	0	0	0	1	0	0	0	0	0	0	0	0	0	0	0/1	0/1	0	Rated range
1023	99.90	-0.2	0	0	0	1	1	1	1	1	1	1	1	1	1	0/1	0/1	0	
1	0.098	-	0	0	0	0	0	0	0	0	0	0	0	0	1	0/1	0/1	0	
0	0.0	-	0	0	0	0	0	0	0	0	0	0	0	0	0	0/1	0/1	0	

A = Active bit  
E = Error bit  
OV = Overflow bit  
S = Sign

When Pt 100 resistance thermometers are connected, the maximum temperature in the rated range is 266 °C. If it can be ensured that the temperature does not exceed 850 °C, the input value may extend into the overrange. The resolution is then 4095 units. Unused inputs can be utilized for voltage measurements in the 500 mV range (see front connector assignments).

**Extended Pt 100 range**

In addition to the standard Pt 100 range, there is an extended Pt 100 range on the 460 analog input module. You can select this with the mode switch.

The following is printed on the cover of the module to set the Pt 100 mode:

Standard range: "resistance thermometer uncompensated full range"  
Extended range: "resistance thermometer compensated low range"

In this range, the basic resistance of the Pt 100 at 0 °C (100 ohms) is compensated for on the module. As in the standard range, the Pt 100 is fed with a constant current of 2.5 mA. Using the overrange (- 100 mV to + 100 mV), this results in a temperature range of approx. -100 °C to + 100 °C.

This measuring range of 200 °C is resolved to 8192 units with the correct sign for the temperature. One unit thus corresponds to approximately 0.025 °C. If you select the extended Pt 100 range, you can use all 8 analog inputs in this range only.

You should only use the 6ES5 498-1AA11 range card (± 50 mV / 500 mV).

Measured-value representation in the extended Pt 100 measuring range (two's complement)

Units	Pt100/ Ohms	Temperature in °C	Byte 0								Byte 1								
			7 S	6 2 <sup>11</sup>	5 2 <sup>10</sup>	4 2 <sup>9</sup>	3 2 <sup>8</sup>	2 2 <sup>7</sup>	1 2 <sup>6</sup>	0 2 <sup>5</sup>	7 2 <sup>4</sup>	6 2 <sup>3</sup>	5 2 <sup>2</sup>	4 2 <sup>1</sup>	3 2 <sup>0</sup>	2 A	1 E	0 OV	
>4095	≥ 140.0		0	1	1	1	1	1	1	1	1	1	1	1	1	0	0	1	Overflow
4095	139.99	103.74	0	1	1	1	1	1	1	1	1	1	1	1	0	0	0	Overrange	
2049	120.01	51.61	0	1	0	0	0	0	0	0	0	0	0	1	0	0	0		
2048	120.0	51.58	0	1	0	0	0	0	0	0	0	0	0	0	0	0	0	Rated range	
+1	100.01	0.026	0	0	0	0	0	0	0	0	0	0	0	1	0	0	0		
0	100.0	0	0	0	0	0	0	0	0	0	0	0	0	0	0	0	0		
-1	99.99	-0.026	1	1	1	1	1	1	1	1	1	1	1	1	0	0	0		
-2048	80	-50.78	1	1	0	0	0	0	0	0	0	0	0	0	0	0	0		
-2049	79.99	-50.81	1	0	1	1	1	1	1	1	1	1	1	1	0	0	0	Overrange	
-4095	60.01	-100.60	1	0	0	0	0	0	0	0	0	0	0	1	0	0	0		
<-4095	≤ 60		1	0	0	0	0	0	0	0	0	0	0	1	0	0	1	Overflow	
Broken wire																			
-4095	Arbitrary	Arbitrary	1	0	0	0	0	0	0	0	0	0	0	0	1	0	0	1	Broken wire Ic+/Ic- <sup>2)</sup>
-4095	Arbitrary	Arbitrary	1	0	0	0	0	0	0	0	0	0	0	1	0	1	1	Broken wire Sensor Measuring line <sup>1)</sup>	

- 1) Only with broken wire monitor activated, error bit = 1 only for faulty channel; for sensor broken wire, overflow bit = 1 for all channels
- 2) On account of the Pt 100 series circuit, this bit combination always appears for all channels if the supply line is open-circuit.

A = Active bit  
 E = Error bit  
 OV = Overflow bit  
 S = Sign

*Measured-value representation for current measuring ranges from 4 to 20 mA*

Measuring range 500 mV; card with 31.25 ohm shunt (6ES5 498-1AA51/AA71)

The 4 to 20 mA range is resolved to 2048 units at an interval of 512 to 2560. If you require a representation from 0 to 2048, you must subtract 512 units by software. Please note the following:

- A broken wire signal cannot be emitted.
- Detection of the overrange can be achieved by scanning bits  $2^9$  and  $2^{11}$ .
- A broken wire can be detected with currents  $< 3$  mA.
- If you short-circuit the positive and negative terminals of the transducer when using the 6ES5 498-1AA51 range card (for a two-wire transducer), the current is limited to about 28 mA. Until the thermal current limiting circuit responds in the range card (about 3 s), a short-circuit current of approximately 250 mA flows; this sets the overflow bit for this duration at all channels.

*Current limiting*

Units	Input Current in mA	Byte 0								Byte 1								
		7 S	6 $2^{11}$	5 $2^{10}$	4 $2^9$	3 $2^8$	2 $2^7$	1 $2^6$	0 $2^5$	7 $2^4$	6 $2^3$	5 $2^2$	4 $2^1$	3 $2^0$	2 A	1 E	0 OV	
$\geq 4096$	$\geq 32.000$	0	1	1	1	1	1	1	1	1	1	1	1	1	0/1	0	1	Overflow
4095	31.992	0	1	1	1	1	1	1	1	1	1	1	1	1	0/1	0	0	Overrange
3072	24.0	0	1	1	0	0	0	0	0	0	0	0	0	0	0/1	0	0	Short-circuit with two-wire transducer
3071	23.992	0	1	0	1	1	1	1	1	1	1	1	1	1	0/1	0	0	
2561	20.008	0	1	0	1	0	0	0	0	0	0	0	0	1	0/1	0	0	
2560	20.0	0	1	0	1	0	0	0	0	0	0	0	0	0	0/1	0	0	
2048	16.0	0	1	0	0	0	0	0	0	0	0	0	0	0	0/1	0	0	Rated range
512	4.0	0	0	0	1	0	0	0	0	0	0	0	0	0	0/1	0	0	
511	3.992	0	0	0	0	1	1	1	1	1	1	1	1	1	0/1	0	0	Range underflow
384	3.0	0	0	0	0	1	1	0	0	0	0	0	0	0	0/1	0	0	
383	2.992	0	0	0	0	1	0	1	1	1	1	1	1	1	0/1	0	0	
0	0	0	0	0	0	0	0	0	0	0	0	0	0	0	0/1	0	0	Broken wire

A = Active bit  
 E = Error bit  
 OV = Overflow bit  
 S = Sign



## 9.3.15

## Technical Specifications

## 6ES5 460-4UA13 Analog Input Module

Rated input ranges with cards for every 4 channels - 6ES5 498-1AA11 - 6ES5 498-1AA21 - 6ES5 498-1AA31 - 6ES5 498-1AA41 - 6ES5 498-1AA51 - 6ES5 498-1AA61 - 6ES5 498-1AA71	$\pm 12.5 \text{ mV} / \pm 50 \text{ mV} / \pm 500 \text{ mV} / \text{Pt } 100$ $\pm 1 \text{ V}$ $\pm 10 \text{ V}$ $\pm 5 \text{ mA} / \pm 20 \text{ mA}$ 4 to 20 mA for two-wire transducer $\pm 5 \text{ V}$ 4 to 20 mA for four-wire transducer
Number of inputs	8 voltage/current inputs or 8 resistance inputs (Pt 100)
Measured-value representation	13 bits (two's complement) or 12 bits + sign; $\pm 2048$ units in rated range; 512 to 2560 units for 4 to 20 mA
Measuring principle	Integrating
Isolation	Yes 8 inputs tested with respect to 0 V at 500 V AC
Permissible potential difference between reference potentials of sensors and the module ( $U_{CM}$ ) and between sensors (channels)	25 V AC/60 V DC max.
Power supply - digital section from system bus - analog section from load voltage - enabling for module F+/F- - tripping current L+	5 V $\pm 5 \%$ , 130 mA typical 24 V, approx. 150 mA 24 V, approx. 5 mA 24 V, approx. 5 mA
Constant current source for Pt 100 connection $I_{C+}/I_{C-}$	2.5 mA, $TC = 5 \times 10^{-5} / K$
Integration time	20 ms at 50 Hz, $16 \frac{2}{3}$ ms at 60 Hz
Encoding time per measured value	60 ms at 50 Hz, 50 ms at 60 Hz

<sup>1)</sup> Plus 20 mA max. per connected two-wire transducer.

Cycle time for 8 measured values with 2048 units (max. delay time for measured-value acquisition)	Approx. 0.48 s at 50 Hz
Input resistance (with card) for input ranges: ± 12.5 mV/± 50 mV/± 500 mV/Pt 100 ± 1 V ± 5 V/± 10 V ± 5 V/± 20 mA 4 to 20 mA	≥ 10 MΩ 90 kΩ 50 kΩ 25 Ω 31.25 Ω
Measuring point-related error signal - for overflow - for broken wire	Yes Yes, configurable (at ± 12.5 mV, ± 50 mV, ± 500 mV and Pt 100 <sup>1)</sup> )
Max. permissible input voltage without destruction	± 18 V; 75 V for 1 ms max. and duty ratio 1:20
Interference suppression for $f = n \times (50/60 \text{ Hz} \pm 1 \%)$ - with common-mode interference - with differential-mode interference	≥ 100 dB ≥ 40 dB, interference voltage amplitude, but 100 % max. of measuring range referred to peak value
Error referred to rated value - linearity - tolerance at ≥ 50 mV at 2.5 mV polarity reversal error at 50 mV at ± 12.5 mV - temperature error	± 1 unit ± 1 unit ± 3 unit ± 1 unit ± 2 unit $1 \times 10^{-4} / \text{K}$
Error caused by modules with input range: ± 1V / ± 5V / ± 10V 20 mA/4 to 20 mA	$2 \times 10^{-3}$ ; TC = ± $10 \times 10^{-5} / \text{K}$ $10^{-3}$ ; TC = $5 \times 10^{-5} / \text{K}$
Voltage test to VDE 0160	Between inputs and ground point, tested at 500 V AC
Surge voltage test to IEC 255-4	Between inputs and L-: $V_p = 1 \text{ kV}, 1.2/50 \mu\text{s}$
Extended Pt 100 measuring range  Measuring range including overrange Resolution Basic error at T = 25 °C Operational error at T = 0 to 65 °C Range card	Approx. - 100 °C to + 100 °C 0.025 °C per unit ± 0.2 °C max. ± 0.5 °C max. 6ES5 498-1AA11
Environmental specifications	See technical specifications of the S5-135U/155U CC

<sup>1)</sup> In the event of open-circuit of the live I<sub>C+</sub> and I<sub>C-</sub> lines, the digital value 0 is indicated.

**Setting the mode**

You select the desired mode of the analog input module by setting mode switches I and II according to the following table. Please note that all switch rockers marked with a dot must be set on both mode switches. To set the desired mode, press the rockers downwards on the side marked with a dot in the table.

Mode	Mode Switch I (Digital Section)	Mode Switch II (Analog Section)
Without reference point compensation		
With reference point compensation		
Measuring range Extended Pt 100 range		
500 mV; mA		
50 mV		
Value and sign		
Two's complement		
Gain x1 (normal setting)		
Gain x4		
Sampling selective		
cyclic		
Line frequency 50 Hz		
60 Hz		
Channels 0 to 3 with broken wire signal		
Channels 4 to 7		
Channels 0 to 3 without broken wire signal		
Channels 4 to 7		

X = Switch is not assigned; any switch setting.

• = Switch setting

Labelling of switches on the module cover:

mark selected switch positions here		mark selected switch positions here			
broken wire detection channel 0...3		VOLTAGE COMPENS.	without compensation		
broken wire detection channel 4...7			with compensation		
without broken wire detection		INPUT RANGE	resistance thermometer compensated low range		
line frequency 50 Hz			500 mV V...mA resistance thermometer uncompensated full range		
line frequency 60 Hz			50 mV		
single scanning		DATA FORMAT	result and sign		
cyclic scanning			two's complement		
SI		submodule 1 (ch. 0...3)	GAIN	normal mode (gain*1)	
				special mode (gain*4)	
		submodule 2 (ch. 4...7)	■ = press		SII

Inserting range cards

On one 460 analog input module, you can insert two cards to connect four inputs each, and secure them with a screw. There are voltage divider, shunt and through-connection cards for the various ranges.

	Range Card Type 6ES5 498-						
	-1AA11	-1AA21	-1AA31	-1AA41	-1AA51	-1AA61	-1AA71
Circuit of the cards, 4x							
Mode 500 mV/ mA Pt 100 + Gain x 1	± 500 mV Pt 100	± 1 V	± 10 V	± 20 mA	4 ... 20 mA 2-wire transducer	± 5 V	4 ... 20 mA 4-wire transducer
Mode 50 mV + Gain x 1	± 50 mV	(± 100 mV)	(± 1 V)	(± 2 mA)	-	(± 500 mV)	-
Mode 500 mV/ mA + Gain x 4	(± 125 mV)	(± 250 mV)	(± 2,5 mV)	(± 5 mA)	-	(± 1,25 V)	-
Mode 50 mV + Gain x 4	(± 12,5 mV)	(± 25 mV)	-	(± 1,25 mA)	-	-	-

For a defined mode (50 mV or 500 mV) you can insert cards with different ranges for four inputs, e.g. for the 500 mV mode:

- 4 inputs, range  $\pm 500$  mV, 1 card 6ES5 498-1AA11
- 4 inputs, range  $\pm 10$  V, 1 card 6ES5 498-1AA31

Front connector assignments Voltage or current-input resistance thermometer or connection of two-wire transducer

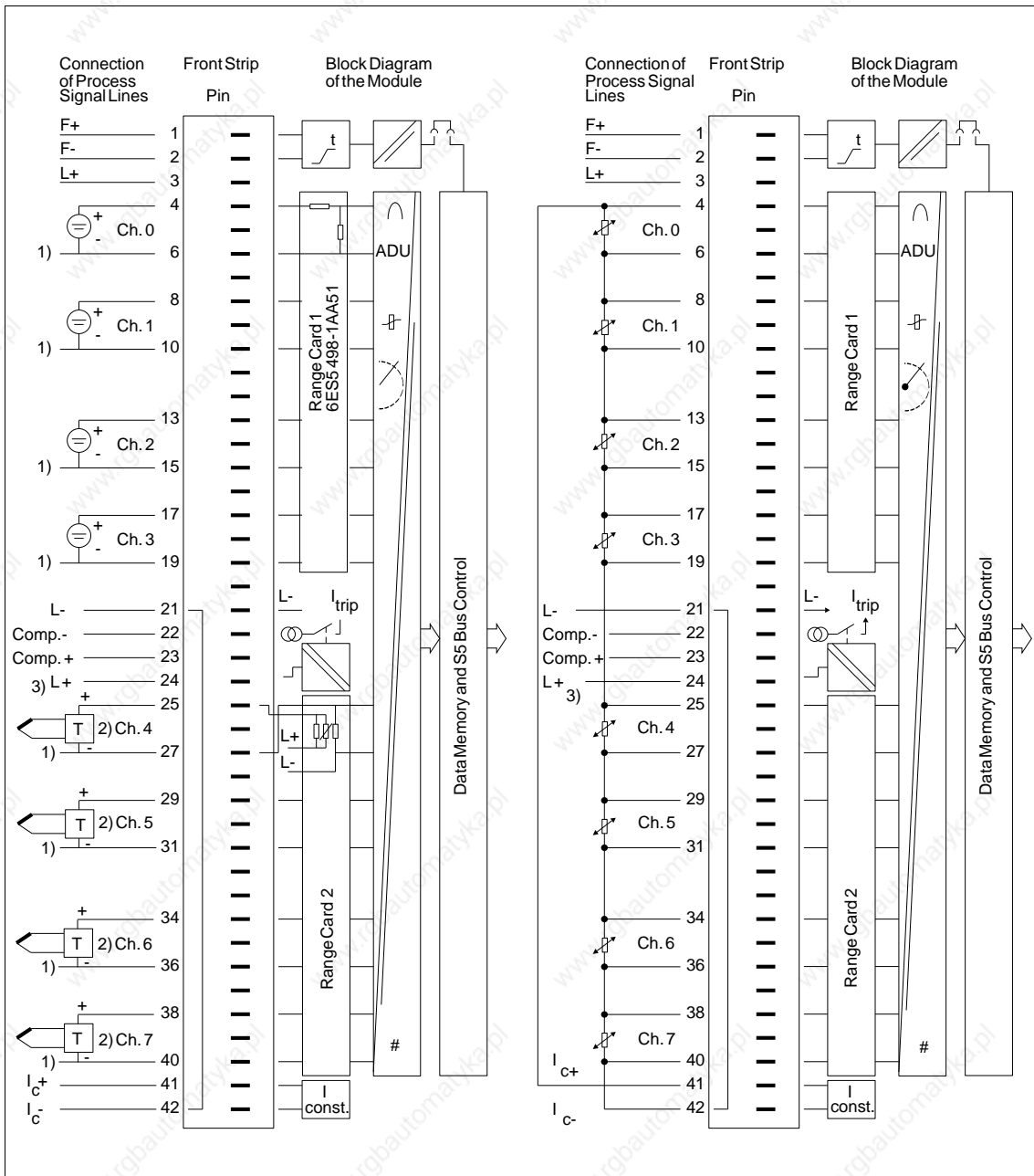

Figure 9-11 Front Connector Assignments

- 1) Observe permissible potential difference between sensor ground and reference potential of modules or between sensor grounds.
- 2) Two-wire transducer
- 3) Only required to switch off the tripping current without broken wire detection; 0 V at L- (see Section 1.3.1).
- 4) Connect L- to the central ground point (reference potential).

## 9.4 The 463 Analog Input Module

### 9.4.1 Design

The modules are designed as plug-in PCBs for central controllers and expansion units with a backplane connector and with a blade connector to accept a plug-in front connector. You can directly connect the process signal lines to the front connector, which is available separately, with screw or crimp terminals.

#### *Addressing switch, mode switches*

Situated on each module is an addressing switch with six rockers to set the module address. Analog input modules also have two switches on the side with eight rockers for setting the mode, and receptacles for range cards.

The modules are protected by covers on both sides.

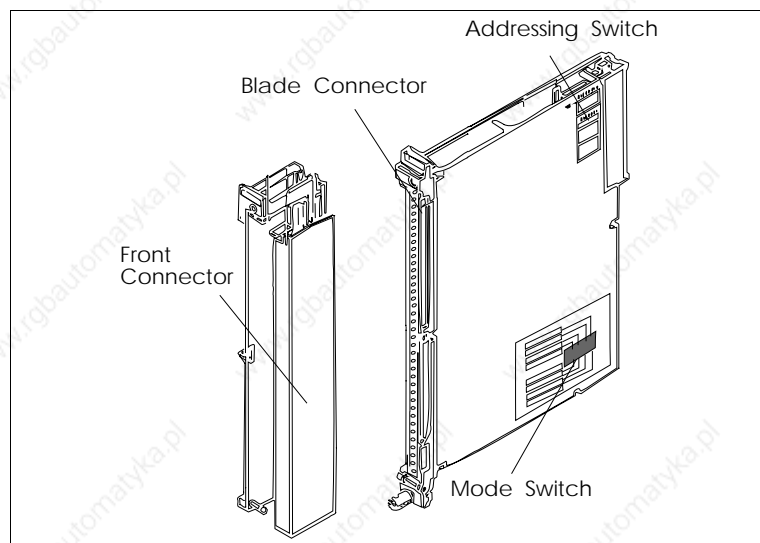

Figure 9-12 Analog Input Module

### 9.4.2

#### **Function of the Enable Input**

The 463 module has an enable circuit. You can use the enable inputs to switch off individual modules whilst the PLC is in operation. This means that:

- The module can no longer be addressed by the user program.

Modules which are switched off can be removed or inserted during operation. If this is not necessary, operate the module with the enable input switched off.

**Enable input**

The enable circuit requires an external 24 V voltage at enable inputs F+/F- in the front connector. If there is no voltage at F+/F-, the modules will not acknowledge.

When the front connector is swivelled away from the front strip of the module, the supply of power to the enable input is interrupted, i.e. the module is switched off and can no longer be addressed by the user program: a timeout (QVZ) occurs in the CC.

**Switching off the enable input**

The -4Ux12 type modules additionally offer the facility for changing the enable mode. The modules have a jumper accessible from above in the vicinity of the addressing switch.

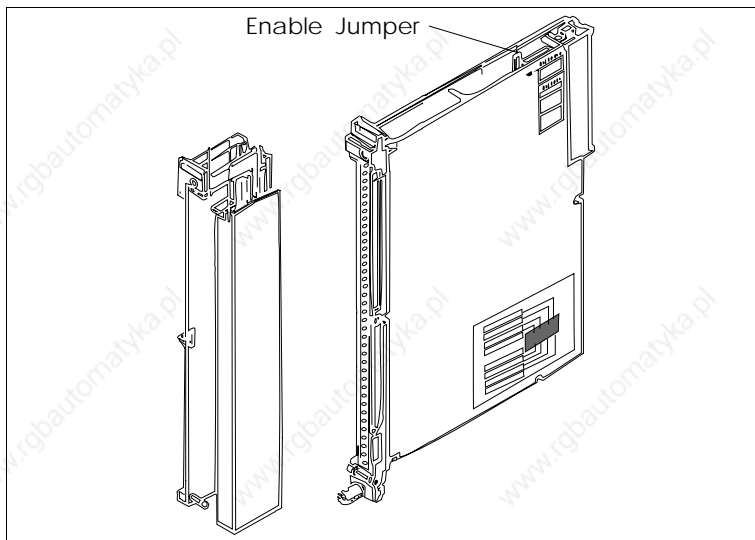

Figure 9-13 Enable Input and Enable Jumper

Jumper inserted: Enable input (F+/F-) active (factory setting)  
Jumper open: Enable input (F+/F-) switched off

**Examples of functioning of the enable inputs:**

- To switch off individual subprocesses, i.e. outputs of various modules can be operated from a common load supply and yet activated separately.
- The load voltage of individual modules can be monitored without additional circuitry. Any reactions to failure of the load voltage can be programmed in the QVZ (timeout) organization block.



**Configuring**

You must observe the following when configuring systems:

Switching on	At the latest 100 ms after power-up of the PLC, the voltage must be present at the enable inputs of the I/O modules.
Switching off	When the PLC has been switched off, the voltage at the enable inputs of the I/O modules must still be present as long as the internal 5 V voltage is present.

**Switching off the CC**

You should observe the following instructions for switching off CCs and equipment for supplying power to the enable inputs.

**Separate or common shutdown of the CC/EU and load power supply**

When there is a need to switch off the load power supply separately without affecting the enabling of modules, there are the following possibilities for producing the enable voltage. These exist even when the load power supply is used without an additional capacitor and common shutdown.

- **230 V AC supply for CC/EU and load power supply**

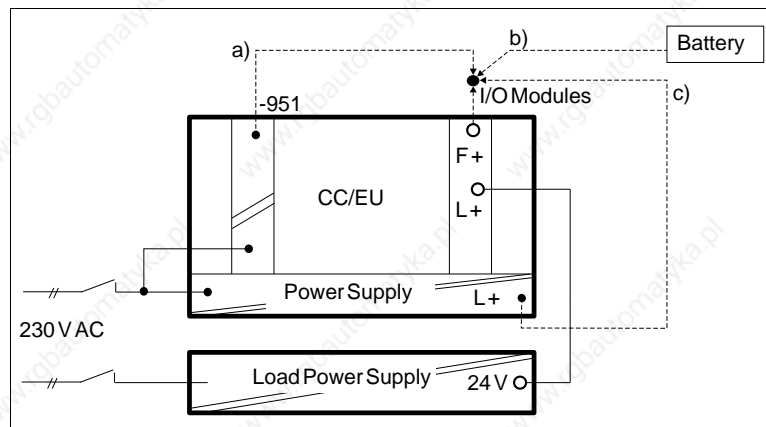

Supply for the enable inputs from:

- a) 6ES5 951-4LB11 load power supply
- b) Battery
- c) Terminals for 24 V on the front plate of the power supply

• **24 V supply for CC/EU and I/Os**



Supply for the enable inputs from:

- a) Battery
- b) Terminals for 24 V on the front plate of the power supply

*Common shutdown of the CC/EU and load power supply with a 230 V AC supply*

Proper functioning is ensured if the 24 V load power supply has an output capacitance of at least 4700  $\mu\text{F}$  per 10 A of load current. Other units which do not meet this condition can be adapted to this requirement by connecting a 10000  $\mu\text{F}/40\text{ V}$  capacitor in parallel.



**9.4.3 Special Features of the 463 Analog Input Module**

The 463 analog input module executes integrating processing of the digital input signals; periodic system interference is thus suppressed.

*Adaptation of the measuring range*

The measuring range for each channel is adapted by appropriately connecting the sensors and with jumpers in the front connector of the module (see the front connector assignments).

9.4.4

**Setting the Module Address**

You set the module address on the addressing switch. This also establishes the necessary assignments between user program and process connection. The module address is the sum of the decimal significances of the switch rockers in the On setting (●).

One data word = two data bytes is required to process an input or an output. A module with 16 inputs therefore reserves 32 byte addresses, and a module with 8 inputs or outputs reserves 16 byte addresses.

*Labelling field*

You can affix the adhesive label with the desired module address on a free labelling field under the addressing switch.

The switch rockers to be set for the module address specified as a decimal number (address bit ADB) are marked by dots on the label.

Press the individual rockers of the addressing switch downwards with a ballpoint pen or similar object, but not a pencil.

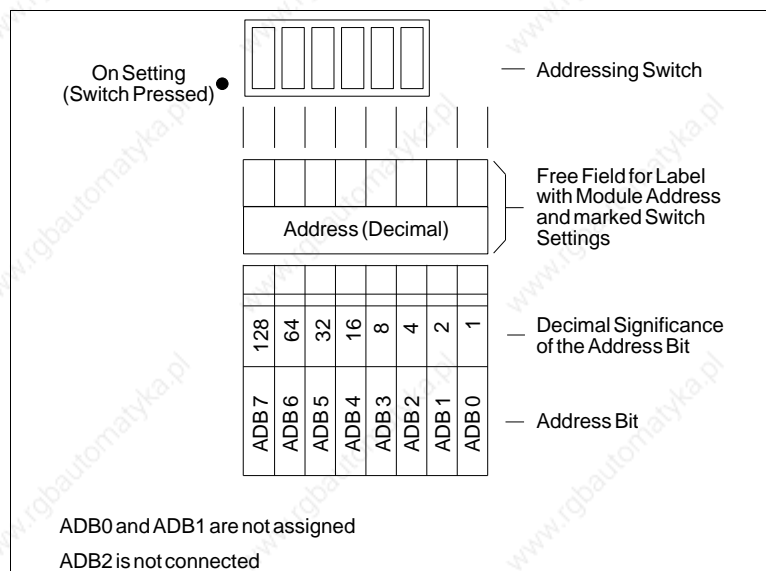

Figure 9-14 Labelling of the Addressing Switch

The address under which the module is referenced by the STEP 5 program is independent of the slot.

*Start address, subaddress*

For analog input and analog output modules (4 inputs) only the lowest address (start address) is set. Other addresses (subaddresses) are decoded on the module.

**Note**

The start address of the analog module must be a multiple of the double channel number.

4 channels : 0, 8, 16, 24, ... 248

If one of the inputs or outputs (Channel 0 to 3) of a module is to be addressed, the relevant subaddress must be specified in the program.

The subaddress of the input or output, based on the start address of the module, is given by:

$$\text{Start address} + 2 \times \text{channel no.} = \text{subaddress}$$

**Example:**

Analog input module with 4 inputs

The address is the sum of the significances set with the individual coding switches.

$$160 = 128 + 32 = 2^7 + 2^5$$

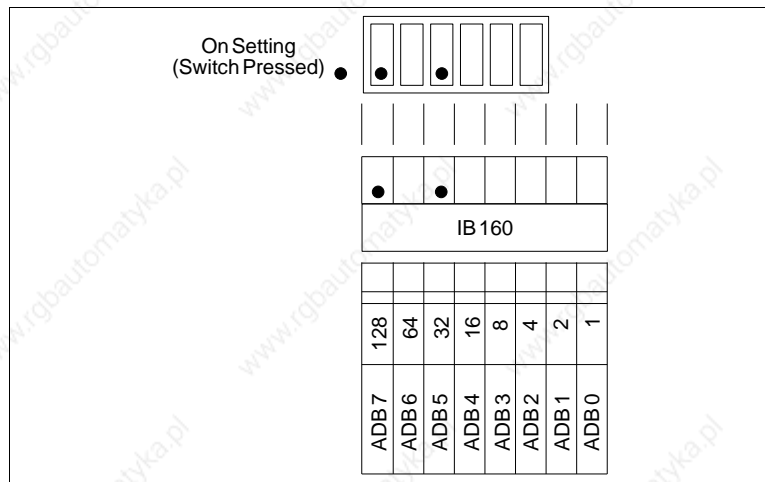

A module with 4 inputs (Channel 0 to 3) and start address 160 reserves the address range from

$$160 \text{ to address } 160 + 3 \times 2 = 166$$

In this example, the next free address for another module is 168.

Addresses already assigned must not be set again.

**Example:**

On an analog input module with start address 160 (IB 160 = input byte 160), input channel 3 is to be scanned by the program.

Step	Action
1	Affix the self-adhesive label with address 160 on the free field under the addressing switch on the module. ADB 5 and ADB 7 are marked on the label.
2	Press the appropriate rockers of the addressing switch down on the side marked by a dot on the module cover. Set the other rockers to the opposite setting. This way sets the start address of the module. ADB 5 and ADB 7 results in $2^5 + 2^7 = 32 + 128 = 160$
3	Enter the address $160 + 3 \times 2 = 166$ in the program for input channel 3.

### 9.4.5 Removing and Inserting Modules



#### Warning

When removing and inserting the front connector during operation, hazardous voltages of more than 25 V AC or 60 V DC may be present at the module pins. When this is the case at the front connector, live modules may only be replaced by electrical specialists or trained personnel in such a way that the module pins are not touched.

During operation, the front connector and module must not be removed or inserted without the enable jumper or active enable circuit.

Install an analog input/output module as follows:

Step	Action
1	Release the upper locking bar on the subrack and swivel it upwards and out.
2	Insert the module at the desired slot in the subrack and push it back in the guides.
3	Latch the module by rotating the locking pin by 90° at the lower end of the module. It must no longer be possible to pull the module forwards.
4	Engage the front connector on the support pin of the module. The width of the support pin also provides keying to prevent front connectors from being fitted to the wrong modules (e.g. front connectors with 115/230 V AC wiring cannot be plugged into analog modules).
5	Tighten the screw in the upper part of the front connector.

Remove an analog input/output module as follows:

Step	Action
1	Release the upper locking bar on the subrack and swivel it upwards and out.
2	Slacken the screw in the upper part of the front connector. This causes the front connector to be pressed out of the female connector of the module. Contacts F+ and F- of the enable input at the upper end of the front connector are thus opened first. If the enable input is active, power is removed from the outputs and the module is isolated from the S5 bus.
3	Swing the front connector out and lift it away from the support pin of the module.
4	Release the module by rotating the locking pin by 90° at the lower end of the module. You can pull the module out of the subrack with a grip with swivels outwards.

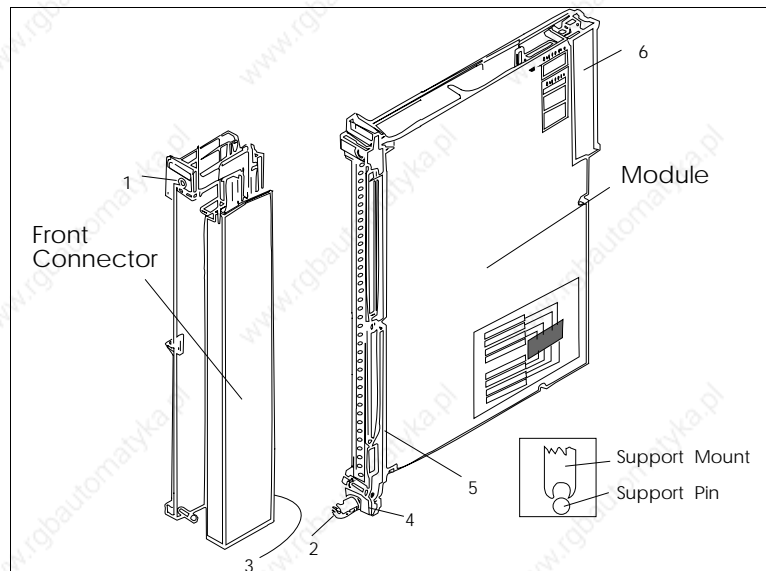

Figure 9-15 Module with Front Connector

- 1 Screw
- 2 Locking pin
- 3 Support mount
- 4 Support pin
- 5 Grip
- 6 Backplane connector

Comply with VDE Specifications 0110 and 0160 to carry out the wiring of supply and signal lines which are to be connected to the programmable controllers and front connectors of the modules.

Detailed information on cabinet assembly, cabinet ventilation and protective measures can be found in Chapter 3.

#### 9.4.6 Marking of Modules and Front Connectors

For the marking of modules and front connectors, labels are supplied with the module and central controller; they are affixed as shown in Figure 9-16.

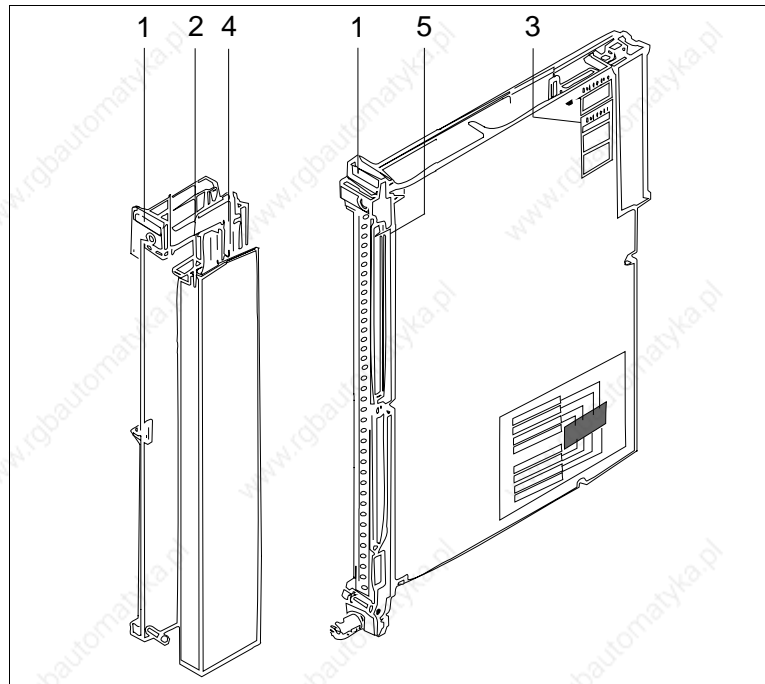

Figure 9-16 Marking and Labelling of Modules

- 1 Label with the module address under which the module is referenced by the STEP 5 program
- 2 Labelling strip with the product designation for the module; space to mark the module version and label the channels
- 3 Label with module address and marking of the required settings for the addressing switch
- 4 Labelling strip for terminal designations or connection diagrams (strip in the cover of the front connector)
- 5 Name plate



**9.4.7****Connecting the Signal Lines**

For connection of the signal lines, front connectors for 20 and 40 mm mounting width with crimp connection and 40 mm mounting width with screw connection are available (screwdriver blade width: 3.5 mm, maximum torque: 0.8 Nm).

Use stranded conductor to facilitate handling of the front connector. Ferrules are not required for screw connections, because the screw terminals are provided with wire protection.

When the crimp contact is inserted in the plastic body of the front connector, a click can clearly be heard. This indicates that the contact is engaged. For jumpering or to correct the wiring, you can remove the contacts with a releasing tool (see ordering information) without having to pull out the front connector.

Ferrules are not required for screw connections, because the screw terminals are provided with wire protection. You can use ferrules of 7 mm in length to DIN 46228. The maximum terminal area is  $2 \times 2.5 \text{ mm}^2$ .

Terminal Type	Connector Type 6ES 497-	Max. No. of Contacts	Cross-Section		Connector for Rated Voltage	Mounting Width of Module
			Signal or Supply Conductor	Aux. Jumper in Connector <sup>1)</sup>		
Crimp connection	-4UA12 <sup>2)</sup>	42	0.5 mm <sup>2</sup>	0.5 mm <sup>2</sup>	5 to 60 V DC	20 mm Operation with fan
	-4UA22 <sup>2)</sup>	42	0.5 mm <sup>2</sup>	0.5 mm <sup>2</sup>	5 to 60 V DC	40 mm
Screw connection	-4UB12	42	0.5 to 2.5 mm <sup>2</sup>	0.5 to 1.0 mm <sup>2</sup>	5 to 60 V DC	40 mm Operation without fan
	-4UB31	42	0.5 to 1.5 mm <sup>2</sup>	0.5 to 1.0 mm <sup>2</sup>	5 to 60 V DC	20 mm

<sup>1)</sup> To multiply the supply and 0 V ground terminals, and to connect the enable input

<sup>2)</sup> The crimp contacts must be ordered separately for these types of connector.

**Caution**

Only extra-low voltage 60 V DC with safety separation from system voltage may be used for the 24 V DC supply and for the 24 V DC input signals. Safety separation can be implemented to the requirements of, amongst other sources, VDE 0100 Part 410/HD 384-4-41/IEC 364-4-41 (as functional extra-low voltage with safety separation) or VDE 0805/EN 60950/IEC 950 (as safety extra-low voltage SELV) or VDE 0106 Part 101.

### 9.4.8 Measured-Value Representation

*Measured-value representation as value and sign* (rated input ranges 0 to 1 V, 0 to 10 V, 0 to 20 mA, 4 to 20 mA)

Units	Rated Range					Byte 0								Byte 1								
	0...10 V	0...1 V mV	0...20 mA	4...20 mA <sup>1)</sup>	4...20 mA <sup>2)</sup>	7 2 <sup>11</sup>	6 2 <sup>10</sup>	5 2 <sup>9</sup>	4 2 <sup>8</sup>	3 2 <sup>7</sup>	2 2 <sup>6</sup>	1 2 <sup>5</sup>	0 2 <sup>4</sup>	7 2 <sup>3</sup>	6 2 <sup>2</sup>	5 2 <sup>1</sup>	4 2 <sup>0</sup>	3	2	1	0	OV
2047	19.99	1999	39.98	35.98	31.98	0	1	1	1	1	1	1	1	1	1	1	1	0	0	0	1	<sup>3)</sup>
1536	15.00	1500	30.00	28.00	24.00	0	1	1	0	0	0	0	0	0	0	0	0	0	0	0	1	
1535	14.99	1499	29.98	27.98	23.98	0	1	0	1	1	1	1	1	1	1	1	1	0	0	0	0	<sup>4)</sup>
1280					20.00	0	1	0	1	0	0	0	0	0	0	0	0	0	0	0	0	
1025	10.01	1001	20.02	20.02	16.02	0	1	0	0	0	0	0	0	0	0	0	1	0	0	0	0	
1024	10.00	1000	20.00	20.00	16.00	0	1	0	0	0	0	0	0	0	0	0	0	0	0	0	0	<sup>5)</sup>
1023	9.99	999.02	19.98	19.98	15.98	0	0	1	1	1	1	1	1	1	1	1	1	1	0	0	0	
512	5.00	500.00	10.00	12.00	8.00	0	0	1	0	0	0	0	0	0	0	0	0	0	0	0	0	
511	4.99	499.00	9.98	11.98	7.98	0	0	0	1	1	1	1	1	1	1	1	1	1	0	0	0	
256		0.976			4.00	0	0	0	1	0	0	0	0	0	0	0	0	0	0	0	0	
1	0.098	0	0.02	4.0156	0.0156	0	0	0	0	0	0	0	0	0	0	0	0	1	0	0	0	
0	0	-	0	4	0	0	0	0	0	0	0	0	0	0	0	0	0	0	0	0	0	
-1	-0.098	0.976	-0.02	3.9844	-0.0156	1	1	1	1	1	1	1	1	1	1	1	1	1	0	0	0	
-51	-0.5	-50	-1	3.184	-0.816	1	1	1	1	1	1	0	0	1	1	0	1	0	0	0	0	

- 1) With data format setting 0 to 1023 (switch on module)
- 2) With data format setting 256 to 1279 (switch on module)
- 3) Overflow
- 4) Overrange
- 5) Rated range

OV = Overflow bit

#### Shunt resistor

A 50 ohm shunt resistor is used for the 0 to 20 mA range; for 4 to 20 mA, the resistor value is 62.5 ohms.

The shunt resistors are permanently fitted to the 463 analog input module. Broken wire detection is not possible.

For the 4 to 20 mA current measuring range, a broken wire can be detected with currents < 3 mA.

#### Current limiting

If the positive and negative terminals of the transducer are short-circuited when two-wire transducers are used (4 to 20 mA), the current is limited to approximately 28 mA. Until the thermal current limiting circuit responds (about 3 s) a short-circuit current of about 250 mA flows; this sets the overflow bit for the short-circuited channel for this duration.

#### Load voltage

The failure of the load voltage can be detected from the result of encoding (values < -51 units).

## 9.4.9

## Technical Specifications

## 6ES5 463-4UA12 and 6ES5 463-4UB12 Analog Input Modules

Rated input ranges (selectable at front connector)	- 0.05 to + 1 V - 0.5 to + 10 V - 1 to + 20 mA + 4 to 20 mA for 2-wire transducer + 4 to 20 mA for 4-wire transducer
Number of inputs	4 voltage/current inputs
Measured value representation	11 bits (two's complement) 1024 units in rated range
Overrange	100 % (with full accuracy)
Error signal for overflow	Yes (upward of 50 % overrange)
Measuring principle	Integrating
Conversion principle	Voltage-frequency conversion
Isolation	Yes, 4 inputs with respect to 0 V and each other
Permissible potential difference between ref. potentials of sensors and module ( $U_{CM}$ ) and between sensors (channels)	25 V AC/60 V DC max.
Power supply - digital section from system bus - analog section from load voltage - enabling of module F+/F-	5 V $\pm$ 5 %, 150 mA typical 24 V, approx. 150 mA 24 V, approx. 7 mA
Integration time - 463-4UA12 - 463-4UB12	20 ms at 50 Hz 16 <sup>2</sup> / <sub>3</sub> ms bei 60 Hz
Encoding time per measured value - 463-4UA12 - 463-4UB12	20 ms at 50 Hz 16 <sup>2</sup> / <sub>3</sub> ms at 60 Hz
Cycle time for 4 measured values (max. delay time of measured value acquisition) - 463-4UA12 - 463-4UB12	20 ms at 50 Hz 16 <sup>2</sup> / <sub>3</sub> ms at 60 Hz
Input resistance for input ranges 1 V 10 V 20 mA 4 to 20 mA	> 10 M $\Omega$ 90 k $\Omega$ 50 $\Omega$ 62.5 $\Omega$
Max. permissible input voltage without destruction	$\pm$ 30 V; 75 V for 1 ms max. and duty ratio 1:10
Interference suppression - with common-mode interference - with differential-mode interference	> 80 dB (f = 0 to 50 kHz) > 40 dB ( $V_{noise} \leq 0.1 U_N$ )
Error, referred to rated value - linearity - tolerance - temperature error	$\pm 5 \times 10^{-4}$ $\pm 1$ unit $0.6 \times 10^{-4}/K$
Voltage test to VDE 0160	Between inputs and ground point, and between 2 inputs; tested at 500 V AC
Surge voltage test to IEC 255-4	Between inputs and L-: $V_p = 1kV; 1.2/50 \mu s$

**Setting the data format for the 4 to 20 mA range**

When using the 4 to 20 mA inputs, you can select data representation of 0 to 1023 bits or 256 to 1279 bits by pressing the appropriate switch. You can choose different data formats for all four input channels.

When the voltage or 0 to 20 mA inputs are used, the relevant switches remain at the opposite settings.

Labelling of the switch on the module cover:

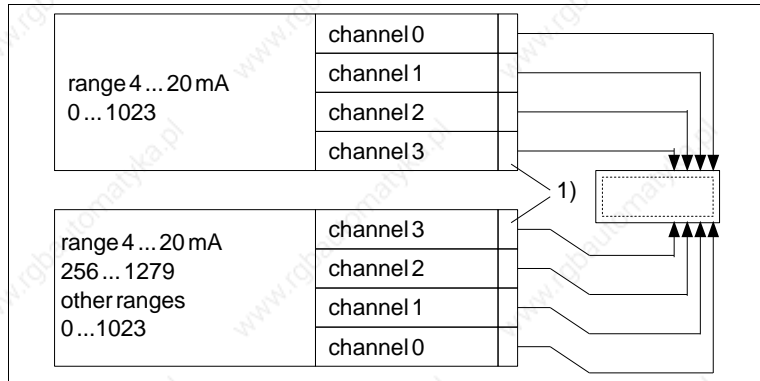

<sup>1)</sup> It is advisable to mark the selected switch setting in these fields.

**Connecting transducers**

Transducers are connected to the analog input module via shielded cables of up to 200 m in length. When they are laid separately from power system cables, distances of up to 500 m are possible.

An arbitrary mixture of voltage sensor, current sensor, two-wire and four-wire transducers can be connected. For two-wire transducers, there are four short-circuit protected supply terminals at the front connector.



**Caution**

To use two-wire transducers, the reference potential (common input) of these channels must be connected to L-. This defeats the isolation between the channels and the supply voltage L+/L-.

Note that the bus interface of the module is activated with 24 V via enable lines F+ and F- at the front connector.

Front connector assignments

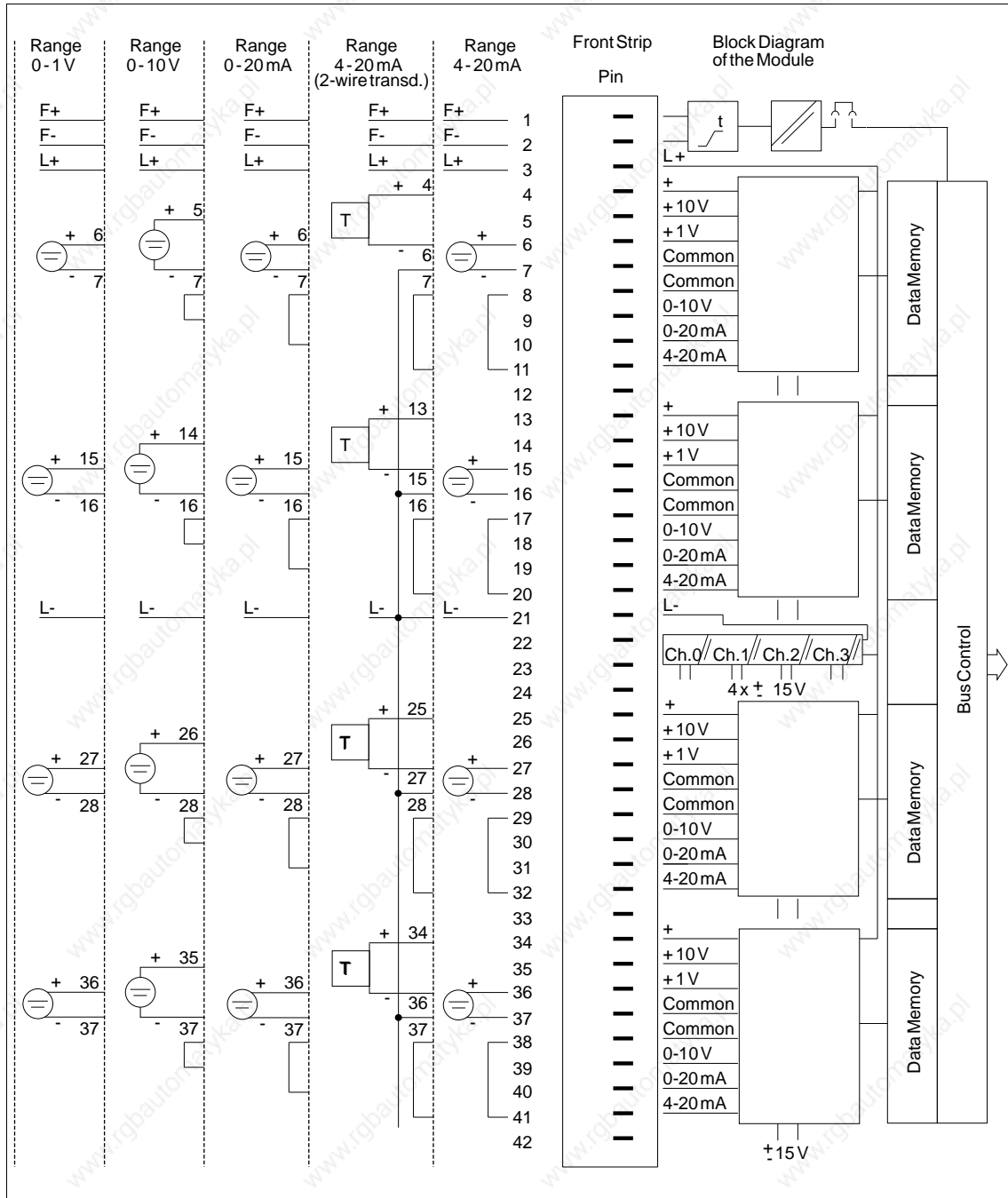

Figure 9-17 Front Connector Assignments, Sensor Connection, Range Selection



## 9.5 The 465 Analog Input Module

### 9.5.1 Design

The modules are designed as plug-in PCBs for central controllers and expansion units with a backplane connector and with a blade connector to accept a plug-in front connector. You can directly connect the process signal lines to the front connector, which is available separately, with screw or crimp terminals.

#### Addressing switch, mode switches

Situated on each module is an addressing switch with six rockers to set the module address. Analog input modules also have two switches on the side with eight rockers for setting the mode, and receptacles for range cards.

The modules are protected by covers on both sides.

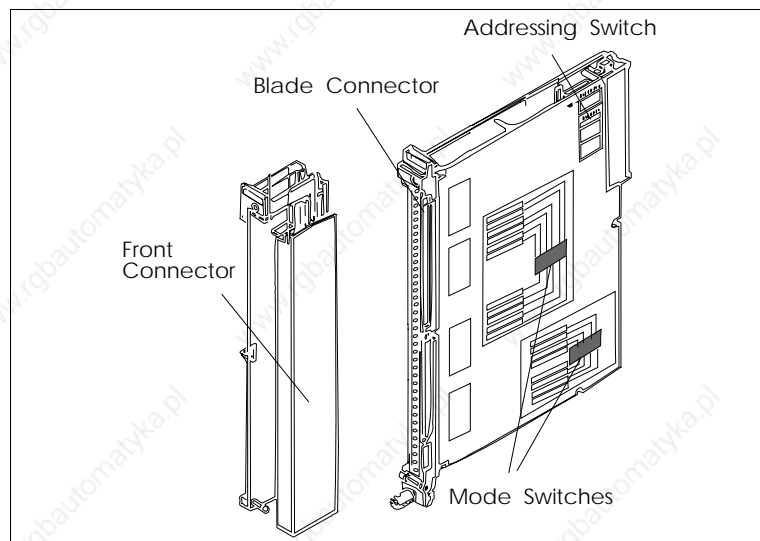

Figure 9-19 Analog Input Module

### 9.5.2 Function of the Enable Input

The 465 module has an enable circuit. You can use the enable inputs to switch off individual modules whilst the PLC is in operation. This means that:

- The module can no longer be addressed by the user program.

Modules which are switched off can be removed or inserted during operation. If this is not necessary, operate the module with the enable input switched off.

**Enable input**

The enable circuit requires an external 24 V voltage at enable inputs F+/F- in the front connector. If there is no voltage at F+/F-, the modules will not acknowledge.

When the front connector is swivelled away from the front strip of the module, the supply of power to the enable input is interrupted, i.e. the module is switched off and can no longer be addressed by the user program: a timeout (QVZ) occurs in the CC.

**Switching off the enable input**

The 465 module additionally offers the facility for changing the enable mode. The module has a jumper accessible from above in the vicinity of the addressing switch.

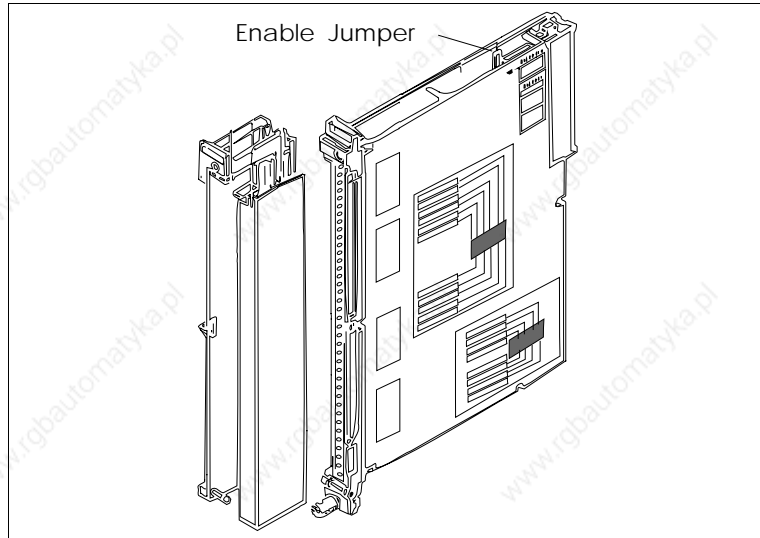

Figure 9-20 Enable Input and Enable Jumper

Jumper inserted: Enable input (F+/F-) active (factory setting)  
Jumper open: Enable input (F+/F-) switched off

**Examples of functioning of the enable inputs:**

- To switch off individual subprocesses, i.e. outputs of various modules can be operated from a common load supply and yet activated separately.
- The load voltage of individual modules can be monitored without additional circuitry. Any reactions to failure of the load voltage can be programmed in the QVZ (timeout) organization block.



**Configuring**

You must observe the following when configuring systems:

Switching on	At the latest 100 ms after power-up of the PLC, the voltage must be present at the enable inputs of the I/O modules.
Switching off	When the PLC has been switched off, the voltage at the enable inputs of the I/O modules must still be present as long as the internal 5 V voltage is present.

**Switching off the CC**

You should observe the following instructions for switching off CCs and equipment for supplying power to the enable inputs.

**Separate or common shutdown of the CC/EU and load power supply**

When there is a need to switch off the load power supply separately without affecting the enabling of modules, there are the following possibilities for producing the enable voltage. These exist even when the load power supply is used without an additional capacitor and common shutdown.

- **230 V AC supply for CC/EU and load power supply**

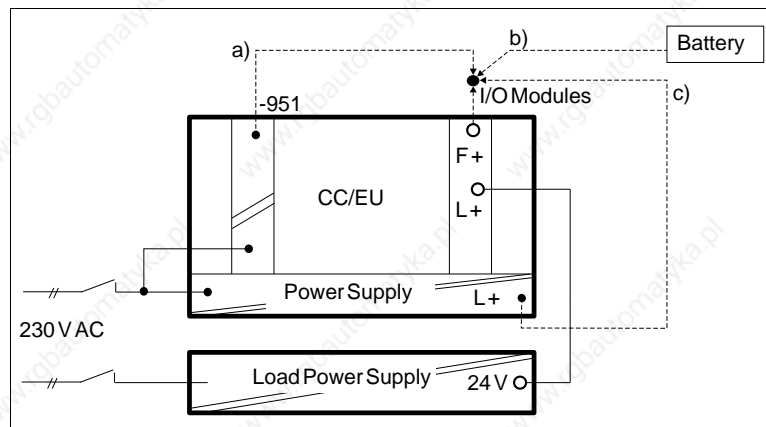

Supply for the enable inputs from:

- a) 6ES5 951-4LB11 load power supply
- b) Battery
- c) Terminals for 24 V on the front plate of the power supply

• 24 V supply for CC/EU and I/Os



Supply for the enable inputs from:

- a) Battery
- b) Terminals for 24 V on the front plate of the power supply

*Common shutdown of the CC/EU and load power supply with a 230 V AC supply*

Proper functioning is ensured if the 24 V load power supply has an output capacitance of at least 4700  $\mu\text{F}$  per 10 A of load current. Other units which do not meet this condition can be adapted to this requirement by connecting a 10000  $\mu\text{F}/40\text{ V}$  capacitor in parallel.



**9.5.3****Special Features of the 465 Analog Input Module**

The 465 analog input module executes integrating processing of the digital input signals; periodic system interference is thus suppressed.

You can adapt the process signals, according to the application, to the input level of the analog-to-digital converter of the module with plug-in range cards (resistor dividers or shunt resistors).

*Broken wire signal*

To monitor the sensors connected to the inputs, you can use the 6ES5 498-1AA11 range card (through-connection card) to implement the "broken wire detection" mode. You can activate broken wire detection for 8 or 16 inputs in 16-channel operation, and for 4 or 8 inputs in 8-channel operation.

Each time the input value is about to be encoded, a constant current is briefly (1.6 ms) switched to the input terminals and the resultant current is checked for a limit value. If a digital voltmeter is used to measure the signal at the input, these current pulses may appear to indicate fluctuation of the signal. The encoded value, however, is not affected.

*Switching the tripping current to the inactive state*

If these apparent fluctuations of the signal are disturbing, e.g. during startup, you can switch the tripping current to the inactive state on the 465 analog input modules: apply + 24 V to pin 24 of the front connector, and 0 V to L-. You must additionally set the mode switch to "without broken wire detection".

In the event of open-circuit of the sensor or its line, the voltage exceeds the limit and a broken wire is indicated (bit 1 in data byte 1). The analog-to-digital converter encodes the value 0.

A broken wire signal is only useful when the 6ES5 498-1AA11 through-connection card is used. With all other measurement cards, a broken wire signal will result in incorrect reactions. Further details relating to the broken wire signal can be found in Section 9.5.10.

*Measuring range exceeded*

If the measuring range is exceeded, the overflow bit (bit 2<sup>0</sup> of the low byte) is set.

*Cyclic sampling/selective sampling*

You have a choice of the cyclic sampling and selective sampling modes.

In the cyclic sampling mode, the module continuously encodes all measured values. The digitized measured values are stored under the channel-related address on the module (the high byte under this address, and the low byte under the next higher address). The measured values can then be read by the module at any time without waiting. When you operate the module in this mode, you can set a module address from 0 to 255.

In the selective sampling mode, a measured value is encoded on the central initiative of the CPU. At the start of conversion, the module must be addressed once with a write operation (T PW) by the user program. An active bit (T = 1) is set during encoding.

With the transition to T = 0, the measured value becomes valid. With non-constant cycle times, there may be non-periodic measured value acquisition. If you operate the module in this mode, you must set a module address from 128 to 255. You can also use the address range from 0 to 127 for selective sampling after appropriate programming in DB 1 of the user program.

**Time-controlled program processing**

Another method is that of time-controlled program processing. With this method, certain program segments (e.g. FB 13) are automatically inserted into program processing at the 100 ms rate by a time-controlled block (OB 13). A constant timebase is thus achieved.

```

FB 13          SPM-B          LEN=22      ABS
                                           SHEET 1
SEGMENT 1
NAME: SELSAMPL          EXAMPLE OF SELECTIVE SAMPLING

0005          :
0006          :
0007          :L  PW 128      READ ANALOG VALUE
0008          :T  FW 128      IN TO AUX: FLAG FW 128
0009          :A  F 129.2     SCAN ACTIVITY =1?
000A          :JC  = END      IF = 1, JUMP TO END
000B          :T  FW 10       IF = 0, MEASURED VALUE IN FW 10
000C          :T  PB 128      INITIATE SAMPLING
000D  END    :                (1ST VALUE INVALID AFTER START)
000E          :
000F          :
0010          :BE
    
```

**Function block**

You can read analog values of analog input modules with a function block from the "basic functions" package.

**BASP (output inhibit)**

The BASP signal is not interpreted by the 465 analog input module.



**Note**

The start address of the analog module must be a multiple of the double channel number.

8 channels : 0, 16, 32, 48, ... 240

16 channels : 0, 32, 64, 96, ... 224

If one of the inputs or outputs (Channel 0 to 7 or 0 to 15) of a module is to be addressed, the relevant subaddress must be specified in the program.

The subaddress of the input or output, based on the start address of the module, is given by:

$$\text{Start address} + 2 \times \text{channel no.} = \text{subaddress}$$

**Example:**

Analog input module with 8 or 16 inputs

The address is the sum of the significances set with the individual coding switches.

$$160 = 128 + 32 = 2^7 + 2^5$$

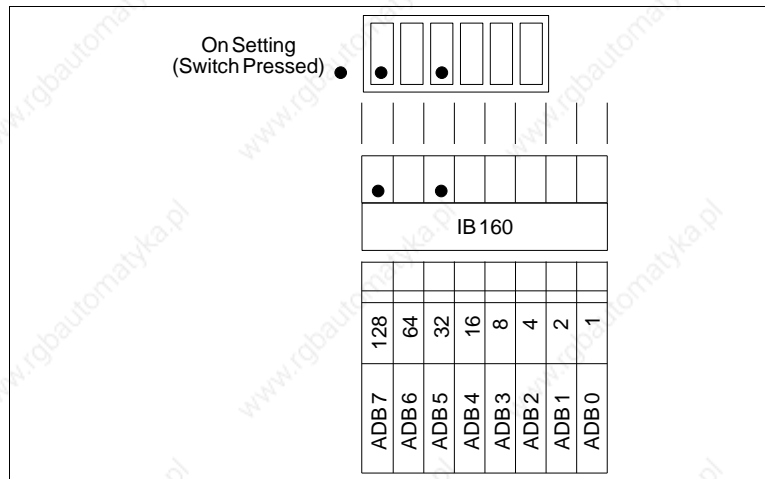

A module with 8 or 16 inputs (Channel 0 to 7 or 0 to 15) and start address 160 reserves the address range from

$$160 \text{ to address } 160 + 7 \times 2 = 174 \text{ or}$$

$$160 \text{ to address } 160 + 15 \times 2 = 190$$

In this example, the next free address for another module is 176 or 192.

With the 465 analog input module, the size of the address range depends on the number of channels set (8 or 16).

Addresses already assigned must not be set again.

**Addressing for cyclic/selective sampling**

However, analog input modules and analog output modules may be given the same address with cyclic sampling because they are distinguished by the user program. This is not possible with selective sampling.

For cyclic sampling, you can address the module in the address range from 0 to 255, and for selective sampling from 128 to 255. For selective sampling, you can also use the address range from 0 to 127 after appropriate programming in DB 1 of the user program.

**Example:**

On an analog input module with start address 160 (IB 160 = input byte 160), input channel 3 is to be scanned by the program.

Step	Action
1	Affix the self-adhesive label with address 160 on the free field under the addressing switch on the module. ADB 5 and ADB 7 are marked on the label.
2	Press the appropriate rockers of the addressing switch down on the side marked by a dot on the module cover. Set the other rockers to the opposite setting. This sets the start address of the module. ADB 5 and ADB 7 results in $2^5 + 2^7 = 32 + 128 = 160$
3	Enter the address $160 + 3 \times 2 = 166$ in the program for input channel 3.

### 9.5.5 Removing and Inserting Modules



#### Warning

When removing and inserting the front connector during operation, hazardous voltages of more than 25 V AC or 60 V DC may be present at the module pins. When this is the case at the front connector, live modules may only be replaced by electrical specialists or trained personnel in such a way that the module pins are not touched.

During operation, the front connector and module must not be removed or inserted without the enable jumper or active enable circuit.

Install an analog input/output module as follows:

Step	Action
1	Release the upper locking bar on the subrack and swivel it upwards and out.
2	Insert the module at the desired slot in the subrack and push it back in the guides.
3	Latch the module by rotating the locking pin by 90° at the lower end of the module. It must no longer be possible to pull the module forwards.
4	Engage the front connector on the support pin of the module. The width of the support pin also provides keying to prevent front connectors from being fitted to the wrong modules (e.g. front connectors with 115/230 V AC wiring cannot be plugged into analog modules).
5	Tighten the screw in the upper part of the front connector.



Remove an analog input/output module as follows:

Step	Action
1	Release the upper locking bar on the subrack and swivel it upwards and out.
2	Slacken the screw in the upper part of the front connector. This causes the front connector to be pressed out of the female connector of the module. Contacts F+ and F- of the enable input at the upper end of the front connector are thus opened first. If the enable input is active, power is removed from the outputs and the module is isolated from the S5 bus.
3	Swing the front connector out and lift it away from the support pin of the module.
4	Release the module by rotating the locking pin by 90° at the lower end of the module. You can pull the module out of the subrack with a grip with swivels outwards.

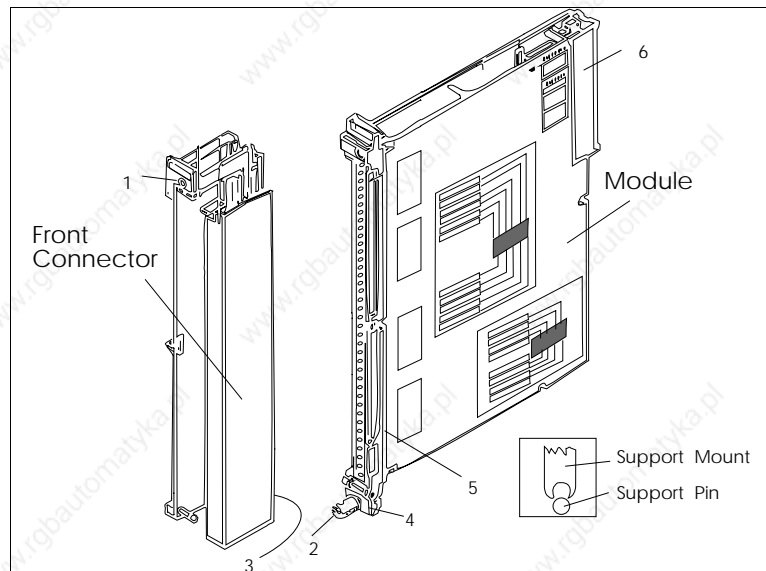

Figure 9-22 Module with Front Connector

- 1 Screw
- 2 Locking pin
- 3 Support mount
- 4 Support pin
- 5 Grip
- 6 Backplane connector

Comply with VDE Specifications 0110 and 0160 to carry out the wiring of supply and signal lines which are to be connected to the programmable controllers and front connectors of the modules.

Detailed information on cabinet assembly, cabinet ventilation and protective measures can be found in Chapter 3.

### 9.5.6 Marking of Modules and Front Connectors

For the marking of modules and front connectors, labels are supplied with the module and central controller; they are affixed as shown in Figure 9-23.

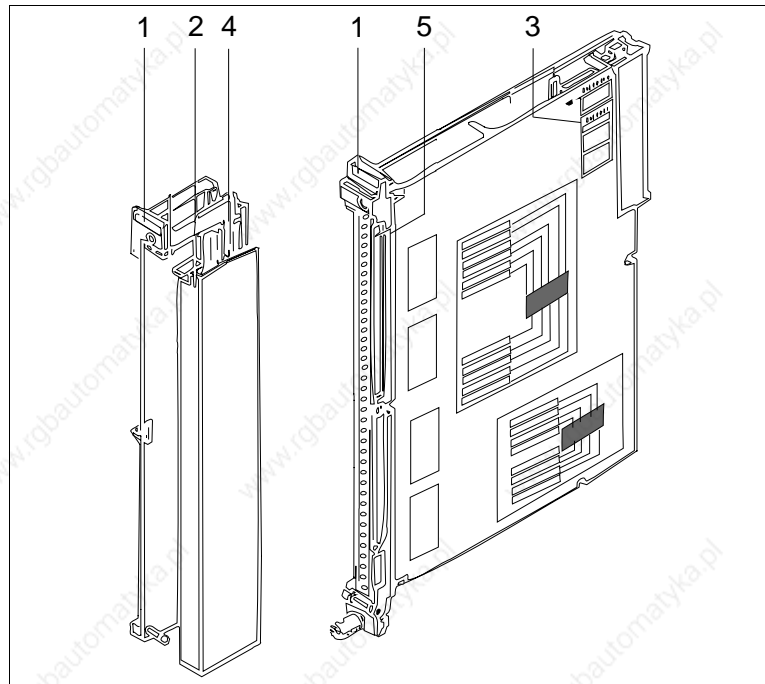

Figure 9-23 Marking and Labelling of Modules

- 1 Label with the module address under which the module is referenced by the STEP 5 program
- 2 Labelling strip with the product designation for the module; space to mark the module version and label the channels
- 3 Label with module address and marking of the required settings for the addressing switch
- 4 Labelling strip for terminal designations or connection diagrams (strip in the cover of the front connector)
- 5 Name plate

**9.5.7****Connecting the Signal Lines**

For connection of the signal lines, front connectors for 20 and 40 mm mounting width with crimp connection and 40 mm mounting width with screw connection are available (screwdriver blade width: 3.5 mm, maximum torque: 0.8 Nm).

Use stranded conductor to facilitate handling of the front connector. Ferrules are not required for screw connections, because the screw terminals are provided with wire protection.

When the crimp contact is inserted in the plastic body of the front connector, a click can clearly be heard. This indicates that the contact is engaged. For jumpering or to correct the wiring, you can remove the contacts with a releasing tool (see ordering information) without having to pull out the front connector.

Ferrules are not required for screw connections, because the screw terminals are provided with wire protection. You can use ferrules of 7 mm in length to DIN 46228. The maximum terminal area is  $2 \times 2.5 \text{ mm}^2$ .

Terminal Type	Connector Type 6ES 497-	Max. No. of Contacts	Cross-Section		Connector for Rated Voltage	Mounting Width of Module
			Signal or Supply Conductor	Aux. Jumper in Connector <sup>1)</sup>		
Crimp connection	-4UA12 <sup>2)</sup>	42	0.5 mm <sup>2</sup>	0.5 mm <sup>2</sup>	5 to 60 V DC	20 mm Operation with fan
	-4UA22 <sup>2)</sup>	42	0.5 mm <sup>2</sup>	0.5 mm <sup>2</sup>	5 to 60 V DC	40 mm
Screw connection	-4UB12	42	0.5 to 2.5 mm <sup>2</sup>	0.5 to 1.0 mm <sup>2</sup>	5 to 60 V DC	40 mm Operation without fan
	-4UB31	42	0.5 to 1.5 mm <sup>2</sup>	0.5 to 1.0 mm <sup>2</sup>	5 to 60 V DC	20 mm

<sup>1)</sup> To multiply the supply and 0 V ground terminals, and to connect the enable input

<sup>2)</sup> The crimp contacts must be ordered separately for these types of connector.

**Caution**

Only extra-low voltage 60 V DC with safety separation from system voltage may be used for the 24 V DC supply and for the 24 V DC input signals. Safety separation can be implemented to the requirements of, amongst other sources, VDE 0100 Part 410/HD 384-4-41/IEC 364-4-41 (as functional extra-low voltage with safety separation) or VDE 0805/EN 60950/IEC 950 (as safety extra-low voltage SELV) or VDE 0106 Part 101.

**9.5.8  
Connecting a  
Compensating Box for  
Thermal E.M.F.  
Measurement**

If the room temperature fluctuations at the reference point (e.g. in the terminal box) affect the measurement result and you do not wish to use a thermostat, you can compensate for the effect of temperature on the reference point with a compensating box. Between - 10 and + 70 °C, it compensates for the change in thermal e.m.f. cause by temperature deviation (compensating box, see Catalog MP 11). Ensure that the compensating box has thermal contact with the terminals.

If the compensating box is aligned at 20 °C, this must be taken into account in temperature evaluation (20 °C measuring point temperature = 0 mV).

Pins 22 and 23 are extended on analog input modules as an input for the compensating voltage. You must select a common input loop for all inputs on mode switch 2.

The compensating box must be connected in a floating circuit. The power supply unit of the compensating box must have a grounded shield winding to avoid AC system interference being picked up. A separate compensating box with its special power supply unit is required for each analog input module.

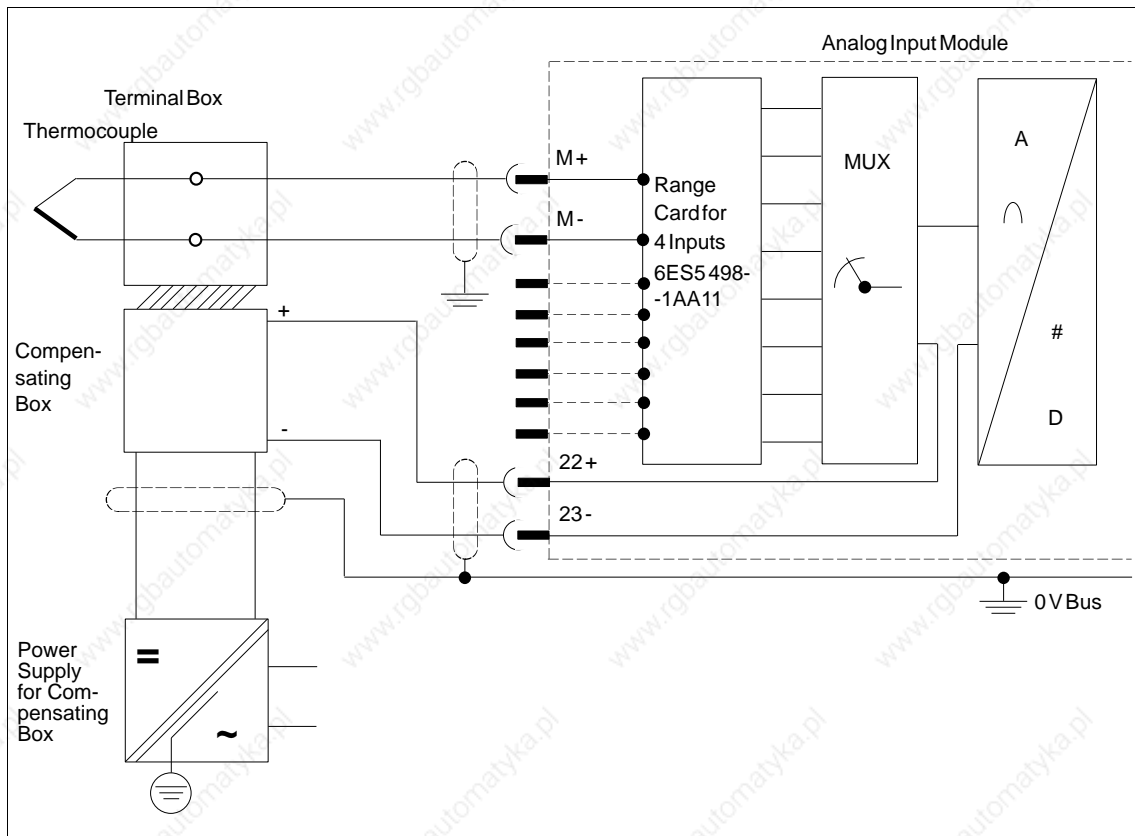

Figure 9-24 Connecting a Compensating Box

**9.5.9  
Connecting Resistance  
Thermometers to the 465  
Analog Input Module**

The relevant resistance thermometer is fed with a current of 2.5 mA ( $I_{C+}/I_{C-}$ ) by a constant current generator via a 6ES5 498-1AA11 card. The voltage at the Pt 100 is picked off at measurement inputs M+ and M-.

If only inputs 0 to 3 are assigned to resistance thermometers, you can connect other current and voltage sensors to inputs 4 to 7 by means of a range card. If you use the Pt 100 for measurement, you cannot utilize channels 12 to 15.

Note that the mode of the module is set to the 500 mV voltage range.

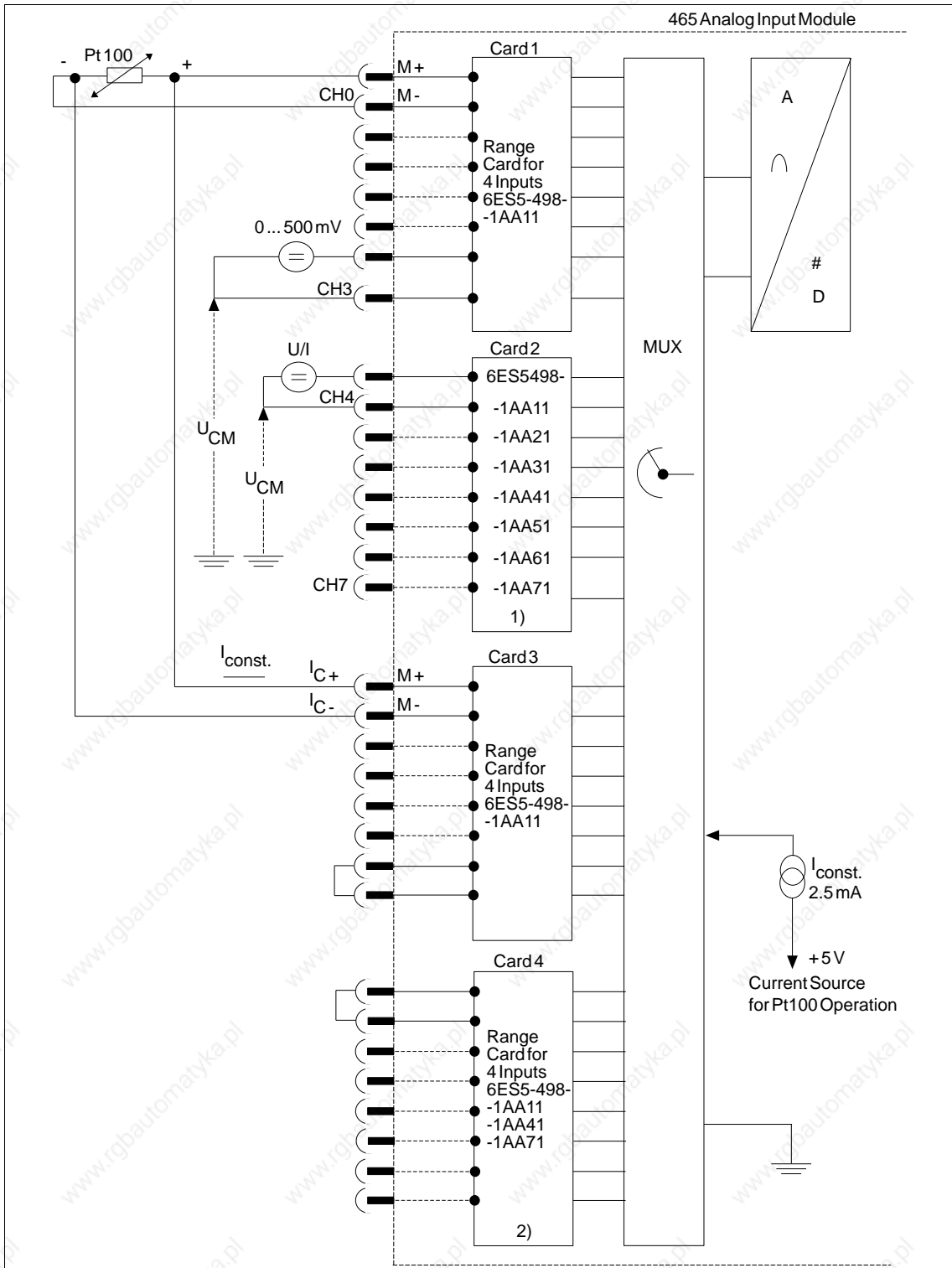

Figure 9-25 Connecting a Pt 100

- 1) When cards 6ES5 498-1AA21, 6ES5 498-1AA31 or 6ES5 498-1AA61 are used, no broken wire signal may be activated for this group of channels (CH4 to CH7).
- 2) If cards 6ES5 498-1AA41 or 6ES5 498-1AA71 are used, a short-circuit jumper is not required.

**9.5.10****Broken Wire Signal for Resistance Thermometers**

An open-circuit in the lines to a resistance thermometer is indicated as follows:

Broken Wire at	Module Reaction, Encoded Value	Error Bit E
M+	0	1
M-	0	1
Pt 100	0	1
I <sub>C+</sub>	0	1
I <sub>C-</sub>	0	1

If the mode "without broken wire signal" is selected on the module, an open-circuit of the resistance thermometer is indicated with an overflow.

Unassigned channels can be used for voltage or current measurement if the current flow outputs relating to the particular measuring channel are shorted with a wire jumper. Without this jumper, the error bit would be set for this channel and the value 0 would be encoded.

**Broken wire monitoring**

When set to "resistance thermometer", switch 7 of mode switch I of the 465 analog input module allows broken wire monitoring of the I<sub>C+</sub> lines to the resistance thermometer (Pt 100 constant current supply). In the event of open-circuit of this line, the error bit is set as for the other lines.

At the "voltage/current" (mV/mA) setting, the I<sub>C+</sub> lines are not monitored for broken wire. (The error bit is not set for an open-circuit of this line.) You should choose this switch setting if you exclusively measure voltages or currents.

9.5.11

Connecting Transducers

Two-wire transducer (short-circuit protected supply voltage via the range card of the analog input module)

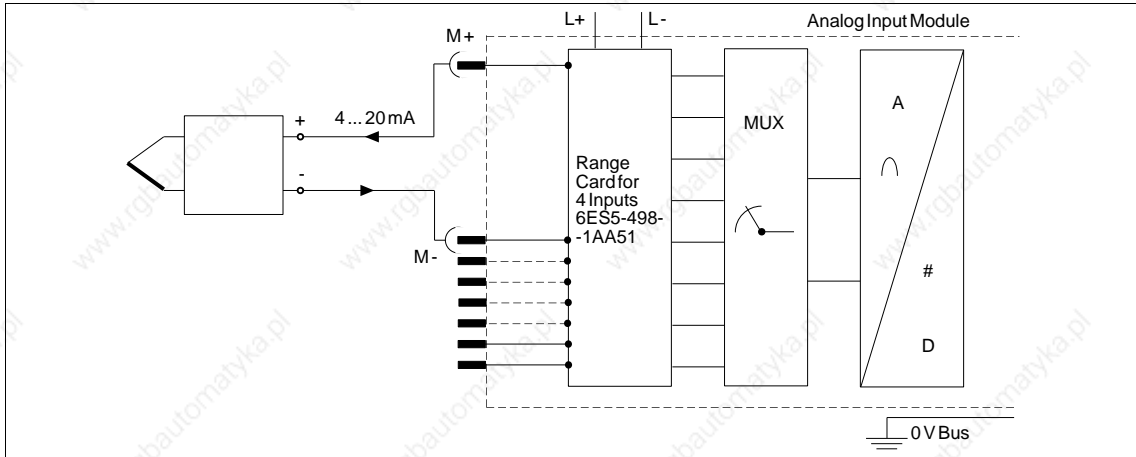

Four-wire transducer (with separate supply voltage)

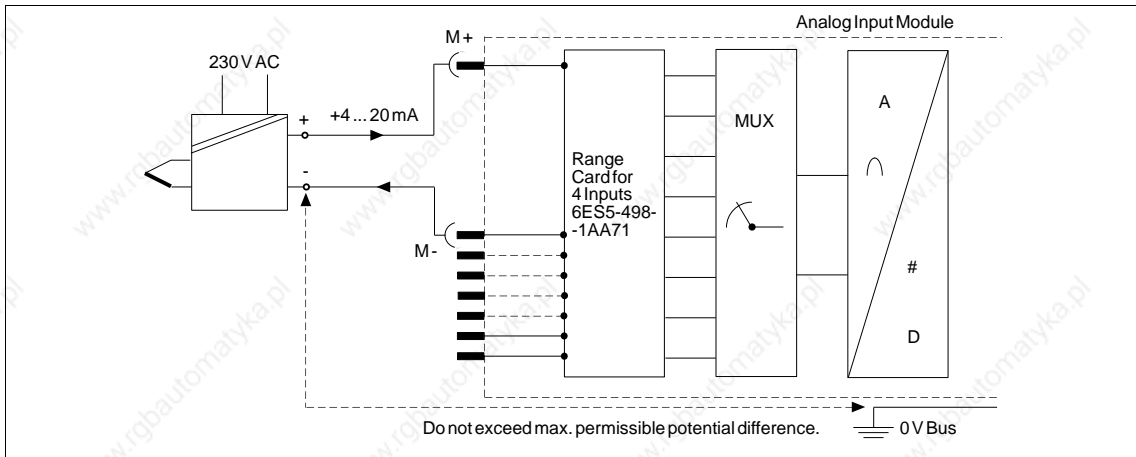

Four-wire transducer with a two-wire transducer card

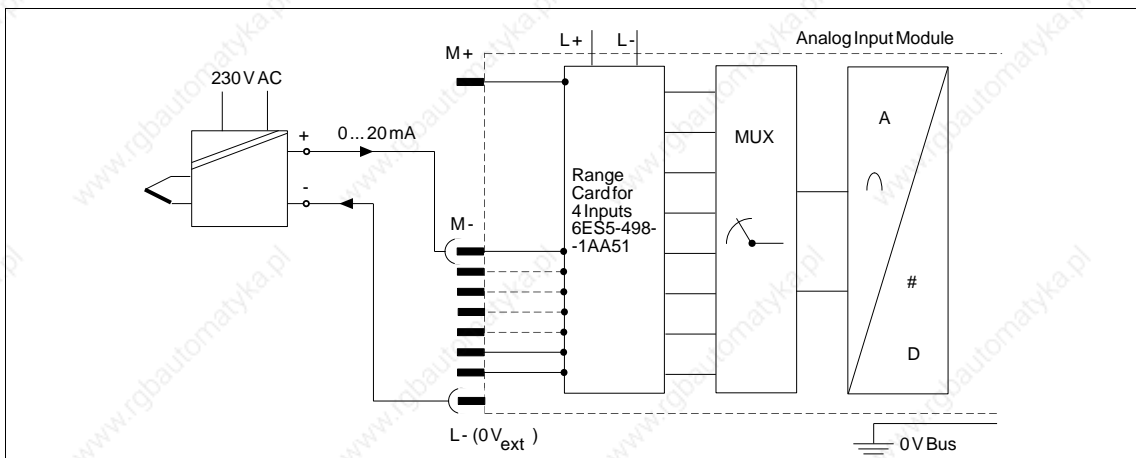



**9.5.12  
Measured-Value  
Representation**

*Digital measured-value representation as two's complement* (rated input range  $\pm 50$  mV)

Units	Input Voltage in mV	Byte 0								Byte 1								
		7 2 <sup>12</sup>	6 2 <sup>11</sup>	5 2 <sup>10</sup>	4 2 <sup>9</sup>	3 2 <sup>8</sup>	2 2 <sup>7</sup>	1 2 <sup>6</sup>	0 2 <sup>5</sup>	7 2 <sup>4</sup>	6 2 <sup>3</sup>	5 2 <sup>2</sup>	4 2 <sup>1</sup>	3 2 <sup>0</sup>	2 A	1 E	0 OV	
$\geq 4096$	100.0	0	1	1	1	1	1	1	1	1	1	1	1	1	0/1	0/1	1	Overflow
4095	99.976	0	1	1	1	1	1	1	1	1	1	1	1	1	0/1	0/1	0	Ovrange
2049	50.024	0	1	0	0	0	0	0	0	0	0	0	0	1	0/1	0/1	0	
2048	50.0	0	1	0	0	0	0	0	0	0	0	0	0	0	0/1	0/1	0	
2047	49.976	0	0	1	1	1	1	1	1	1	1	1	1	1	0/1	0/1	0	
1024	25.0	0	0	1	0	0	0	0	0	0	0	0	0	0	0/1	0/1	0	
1023	23.976	0	0	0	1	1	1	1	1	1	1	1	1	1	0/1	0/1	0	
1	0.024	0	0	0	0	0	0	0	0	0	0	0	0	1	0/1	0/1	0	
0	0.0	0	0	0	0	0	0	0	0	0	0	0	0	0	0/1	0/1	0	Rated range
-1	-0.024	1	1	1	1	1	1	1	1	1	1	1	1	1	0/1	0/1	0	
-1023	-24.976	1	1	1	0	0	0	0	0	0	0	0	0	1	0/1	0/1	0	
-1024	-25.0	1	1	1	0	0	0	0	0	0	0	0	0	0	0/1	0/1	0	
-2047	-49.976	1	1	0	0	0	0	0	0	0	0	0	0	1	0/1	0/1	0	
-2048	-50.0	1	1	0	0	0	0	0	0	0	0	0	0	0	0/1	0/1	0	
-2049	-50.024	1	0	1	1	1	1	1	1	1	1	1	1	1	0/1	0/1	0	Ovrange
-4095	-99.976	1	0	0	0	0	0	0	0	0	0	0	0	1	0/1	0/1	0	
-4096	-100.0	1	0	0	0	0	0	0	0	0	0	0	0	1	0/1	0/1	1	Overflow

A = Active bit  
E = Error bit  
OV = Overflow bit

Digital measured-value representation as value and sign (rated input range  $\pm 50$  mV)

Units	Input Voltage in mV	Byte 0								Byte 1								
		7 S	6 $2^{11}$	5 $2^{10}$	4 $2^9$	3 $2^8$	2 $2^7$	1 $2^6$	0 $2^5$	7 $2^4$	6 $2^3$	5 $2^2$	4 $2^1$	3 $2^0$	2 A	1 E	0 OV	
$\geq 4096$	100.0	0	1	1	1	1	1	1	1	1	1	1	1	1	0/1	0/1	1	Overflow
4095	99.976	0	1	1	1	1	1	1	1	1	1	1	1	1	0/1	0/1	0	Overrange
2049	50.024	0	1	0	0	0	0	0	0	0	0	0	0	1	0/1	0/1	0	
2048	50.0	0	1	0	0	0	0	0	0	0	0	0	0	0	0/1	0/1	0	
2047	49.976	0	0	1	1	1	1	1	1	1	1	1	1	1	0/1	0/1	0	
1024	25.0	0	0	1	0	0	0	0	0	0	0	0	0	0	0/1	0/1	0	
1023	23.976	0	0	0	1	1	1	1	1	1	1	1	1	1	0/1	0/1	0	
1	0.024	0	0	0	0	0	0	0	0	0	0	0	0	1	0/1	0/1	0	
0	0.0	0	0	0	0	0	0	0	0	0	0	0	0	0	0/1	0/1	0	Rated range
-0	0.0	1	0	0	0	0	0	0	0	0	0	0	0	0	0/1	0/1	0	
-1	-0.024	1	0	0	0	0	0	0	0	0	0	0	0	1	0/1	0/1	0	
-1023	-24.976	1	0	0	1	1	1	1	1	1	1	1	1	1	0/1	0/1	0	
-1024	-25.0	1	0	1	0	0	0	0	0	0	0	0	0	0	0/1	0/1	0	
-2047	-49.976	1	0	1	1	1	1	1	1	1	1	1	1	1	0/1	0/1	0	
-2048	-50.0	1	1	0	0	0	0	0	0	0	0	0	0	0	0/1	0/1	0	
-2049	-50.024	1	1	0	0	0	0	0	0	0	0	0	0	1	0/1	0/1	0	Overrange
-4095	-99.976	1	1	1	1	1	1	1	1	1	1	1	1	1	0/1	0/1	0	
-4096	-100.0	1	1	1	1	1	1	1	1	1	1	1	1	1	0/1	0/1	1	Overflow

A = Active bit  
 E = Error bit  
 OV = Overflow bit  
 S = Sign

Bit  $2^{12}$  is interpreted as the sign.

*Measured-value representation for Pt 100 resistance thermometers*

The resolution with Pt 100 resistance thermometers is approximately 0.25 °C.

1 ohm ≡ 10 units

Inputs	Resistance in Ohms	Temperature in °C	Byte 0								Byte 1								
			7 S	6 2 <sup>11</sup>	5 2 <sup>10</sup>	4 2 <sup>9</sup>	3 2 <sup>8</sup>	2 2 <sup>7</sup>	1 2 <sup>6</sup>	0 2 <sup>5</sup>	7 2 <sup>4</sup>	6 2 <sup>3</sup>	5 2 <sup>2</sup>	4 2 <sup>1</sup>	3 2 <sup>0</sup>	2 A	1 E	0 OV	
4096	400.0	-	0	1	1	1	1	1	1	1	1	1	1	1	1	0/1	0/1	1	Overflow
4095	399.90	-	0	1	1	1	1	1	1	1	1	1	1	1	1	0/1	0/1	0	Overrange
2049	200.098	69.1	0	1	0	0	0	0	0	0	0	0	0	0	1	0/1	0/1	0	
2048	200.0	66.5	0	1	0	0	0	0	0	0	0	0	0	0	0	0/1	0/1	0	
2047	199.90	66.0	0	0	1	1	1	1	1	1	1	1	1	1	1	0/1	0/1	0	
1024	100.00	0	0	0	1	0	0	0	0	0	0	0	0	0	0	0/1	0/1	0	Rated range
1023	99.90	-0.2	0	0	0	1	1	1	1	1	1	1	1	1	1	0/1	0/1	0	
1	0.098	-	0	0	0	0	0	0	0	0	0	0	0	0	1	0/1	0/1	0	
0	0.0	-	0	0	0	0	0	0	0	0	0	0	0	0	0	0/1	0/1	0	

A = Active bit  
 E = Error bit  
 OV = Overflow bit  
 S = Sign

When Pt 100 resistance thermometers are connected, the maximum temperature in the rated range is 266 °C. If it can be ensured that the temperature does not exceed 850 °C, the input value may extend into the overrange. The resolution is then 4095 units. Unused inputs can be utilized for voltage measurements in the 500 mV range (see front connector assignments).

*Measured-value representation for current measuring ranges from 4 to 20 mA*

Measuring range 500 mV; card with 31.25 ohm shunt (6ES5 498-1AA51/AA71)

The 4 to 20 mA range is resolved to 2048 units at an interval of 512 to 2560. If you require a representation from 0 to 2048, you must subtract 512 units by software. Please note the following:

- A broken wire signal cannot be emitted.
- Detection of the overrange can be achieved by scanning bits  $2^9$  and  $2^{11}$ .
- A broken wire can be detected with currents  $< 3$  mA.
- If you short-circuit the positive and negative terminals of the transducer when using the 6ES5 498-1AA51 range card (for a two-wire transducer), the current is limited to about 28 mA. Until the thermal current limiting circuit responds in the range card (about 3 s), a short-circuit current of approximately 250 mA flows; this sets the overflow bit for this duration at all channels.

*Current limiting*

Units	Input Current in mA	Byte 0								Byte 1								
		7 S	6 $2^{11}$	5 $2^{10}$	4 $2^9$	3 $2^8$	2 $2^7$	1 $2^6$	0 $2^5$	7 $2^4$	6 $2^3$	5 $2^2$	4 $2^1$	3 $2^0$	2 A	1 E	0 OV	
$\geq 4096$	$\geq 32.000$	0	1	1	1	1	1	1	1	1	1	1	1	1	0/1	0	1	Overflow
4095	31.992	0	1	1	1	1	1	1	1	1	1	1	1	1	0/1	0	0	Overrange
3072	24.0	0	1	1	0	0	0	0	0	0	0	0	0	0	0/1	0	0	Short-circuit with two-wire transducer
3071	23.992	0	1	0	1	1	1	1	1	1	1	1	1	1	0/1	0	0	
2561	20.008	0	1	0	1	0	0	0	0	0	0	0	0	1	0/1	0	0	
2560	20.0	0	1	0	1	0	0	0	0	0	0	0	0	0	0/1	0	0	
2048	16.0	0	1	0	0	0	0	0	0	0	0	0	0	0	0/1	0	0	Rated range
512	4.0	0	0	0	1	0	0	0	0	0	0	0	0	0	0/1	0	0	
511	3.992	0	0	0	0	1	1	1	1	1	1	1	1	1	0/1	0	0	Range underflow
384	3.0	0	0	0	0	1	1	0	0	0	0	0	0	0	0/1	0	0	
383	2.992	0	0	0	0	1	0	1	1	1	1	1	1	1	0/1	0	0	
0	0	0	0	0	0	0	0	0	0	0	0	0	0	0	0/1	0	0	Broken wire

A = Active bit  
 E = Error bit  
 OV = Overflow bit  
 S = Sign

## 9.5.13

## Technical Specifications

## 6ES5 465-4UA12 Analog Input Module

Rated input ranges with cards for every 4 channels - 6ES5 498-1AA11 - 6ES5 498-1AA21 - 6ES5 498-1AA31 - 6ES5 498-1AA41 - 6ES5 498-1AA51 - 6ES5 498-1AA61 - 6ES5 498-1AA71	$\pm 50 \text{ mV}/\pm 500 \text{ mV}/\text{Pt } 100$ $\pm 1 \text{ V}$ $\pm 10 \text{ V}$ $\pm 20 \text{ mA}$ 4 to 20 mA for 2-wire transducer $\pm 5 \text{ V}$ 4 to 20 mA for 4-wire transducer
Number of inputs	16 voltage/current inputs or 8 resistance inputs (Pt 100)
Measured-value representation	13 bits (two's complement) or 12 bits + sign; $\pm 2048$ units in rated range; 512 to 2560 units for 4 to 20 mA
Measuring principle	Integrating
Isolation	No
Permissible potential difference between ref. potentials of sensors and the module ( $U_{CM}$ ), and between sensors (channels)	$\pm 1 \text{ V max.}$
Power supply - digital section from system bus - analog section from load voltage - enabling of module F+/F- - tripping current shutdown L+	5 V $\pm 5 \%$ , 150 mA typical 24 V 24 V, approx. 5 mA 24 V, approx. 5 mA
Constant current source for Pt 100 connection $I_{C+}/I_{C-}$	2.5 mA; $TC = \pm 5 \times 10^{-5}/K$
Integration time	20 ms at 50 Hz, $16^{2/3}$ ms at 60 Hz
Decoding time per measured value for 2048 units	60 ms at 50 Hz, 50 ms at 60 Hz
Cycle time (max. delay of measured value acquisition) - for 8 measured values with 2048 units - for 16 measured values with 2048 units	Approx. 0.48 s at 50 Hz Approx. 0.96 s at 50 Hz
Input resistance (with card) for input ranges $\pm 50 \text{ mV}/\pm 500 \text{ mV}/\text{Pt } 100$ $\pm 1 \text{ V}$ $\pm 5 \text{ V}/\pm 10 \text{ V}$ $\pm 20 \text{ mA}$ 4 to 20 mA	$\geq 10 \text{ M}\Omega$ 90 k $\Omega$ 50 k $\Omega$ 25 $\Omega$ 31.25 $\Omega$

## The 465 Analog Input Module

Measuring point-related error signal - for overflow - for broken wire	Yes Yes, configurable (at $\pm 50$ mV, $\pm 500$ mV and Pt 100)
Max. permissible input voltage without destruction	$\pm 18$ V; 75 V for 1 ms max. and duty ratio 1:20
Interference suppression for $f = n \times (50/60 \text{ Hz} \pm 1 \%)$ - with common-mode interference - with differential-mode interference	$\geq 86$ dB, but $\pm 1$ V max. $\geq 40$ dB, noise voltage amplitude but 100 % max. of measuring range, referred to the peak value
Error, referred to rated value - linearity - tolerance - polarity reversal error - temperature error	$\pm 1$ unit $\pm 1$ unit $\pm 1$ unit $1 \times 10^{-4} / \text{K}$
Error caused by cards with input range $\pm 1 \text{ V} / \pm 5 \text{ V} / \pm 10 \text{ V}$ $\pm 20 \text{ mA} / 4 \text{ to } 20 \text{ mA}$	$2 \times 10^{-3}$ ; TC = $\pm 10 \times 10^{-5} / \text{K}$ $1 \times 10^{-3}$ ; TC = $\pm 5 \times 10^{-5} / \text{K}$

### Setting the mode

You select the desired mode of the analog input module by setting mode switches I and II according to the following table.

Note that all the rockers of both mode switches marked with a dot must be set, and some functions are defined by several rockers (e.g. 8- to 16-channel operation, broken wire signal for 8 or 16 channels).

To activate the desired modes, press the rockers down on the side marked with a dot.

Mode	Mode Switch I (Digital Section)	Mode Switch II (Analog Section)
without reference point compensation		
with reference point compensation		
Measuring range 50 mV		
500 mV; Pt 100		
Current or voltage measurement, 16 channels Pt 100 in 4-wire circuit 8 channels Current or voltage measurement, 8 channels		
Sampling selective		
cyclic		
Line frequency 50 Hz		
60 Hz		
8 channels		
16 channels		
Two's complement		
Value and sign		
Channels 4 ... 7 (with 8 channels) Channels 8 ... 15 (with 16 channels) with broken wire signal		
Channels 0 ... 3 (with 8 channels) Channels 0 ... 7 (with 16 channels)		
Channels 0 ... 3 (with 8 channels) Channels 0 ... 7 (with 16 channels) without broken wire signal		
mV/mA		
Pt 100		

x = Switch is not assigned, any switch setting

● = Switch setting

Labelling of switches on the module cover:

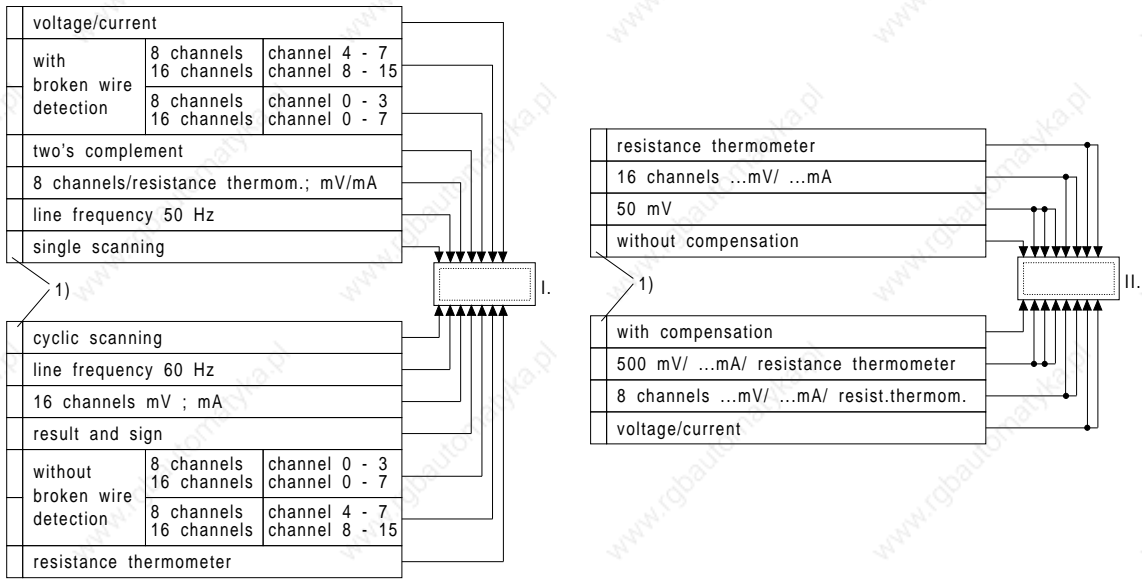

1) It is advisable to mark the selected switch setting in these fields.

**Inserting range cards**

On one 465 analog input module, you can insert four cards for the connection of four inputs each, and secure them with a screw.

There are voltage divider, shunt and through-connection cards for the various ranges.

		Range Card Type 6ES5 498-						
		-1AA11	-1AA21	-1AA31	-1AA41	-1AA51	-1AA61	-1AA71
Circuits of the cards 4x								
Mode 500 mV/ mA Pt 100		± 500 mV Pt 100	± 1 V	± 10 V	± 20 mA	4 ... 20 mA 2-wire trans.	± 5 V	4 ... 20 mA 4-wire trans.
Mode 50 mV		± 50 mV	(± 100 mV)	(± 1 V)	(± 2 mA)	-	(± 500 mV)	-

For a defined mode (50 mV or 500 mV), you can insert cards with different ranges for every four inputs, e.g. for the 500 mV mode:

- 4 inputs, range ± 500 mV; 1 card 6ES5 498-1AA11
- 8 inputs, range ± 20 mA; 2 cards 6ES5 498-1AA41

Unused inputs must be short-circuited (with Pt 100 operation, this also applies to the unused current outputs).

Note that the bus interface of the module is activated with 24 V via enable lines F+ and F- at the front connector.



Front connector assignments

Voltage or current input  
or connection of two-wire transducer

Resistance thermometer

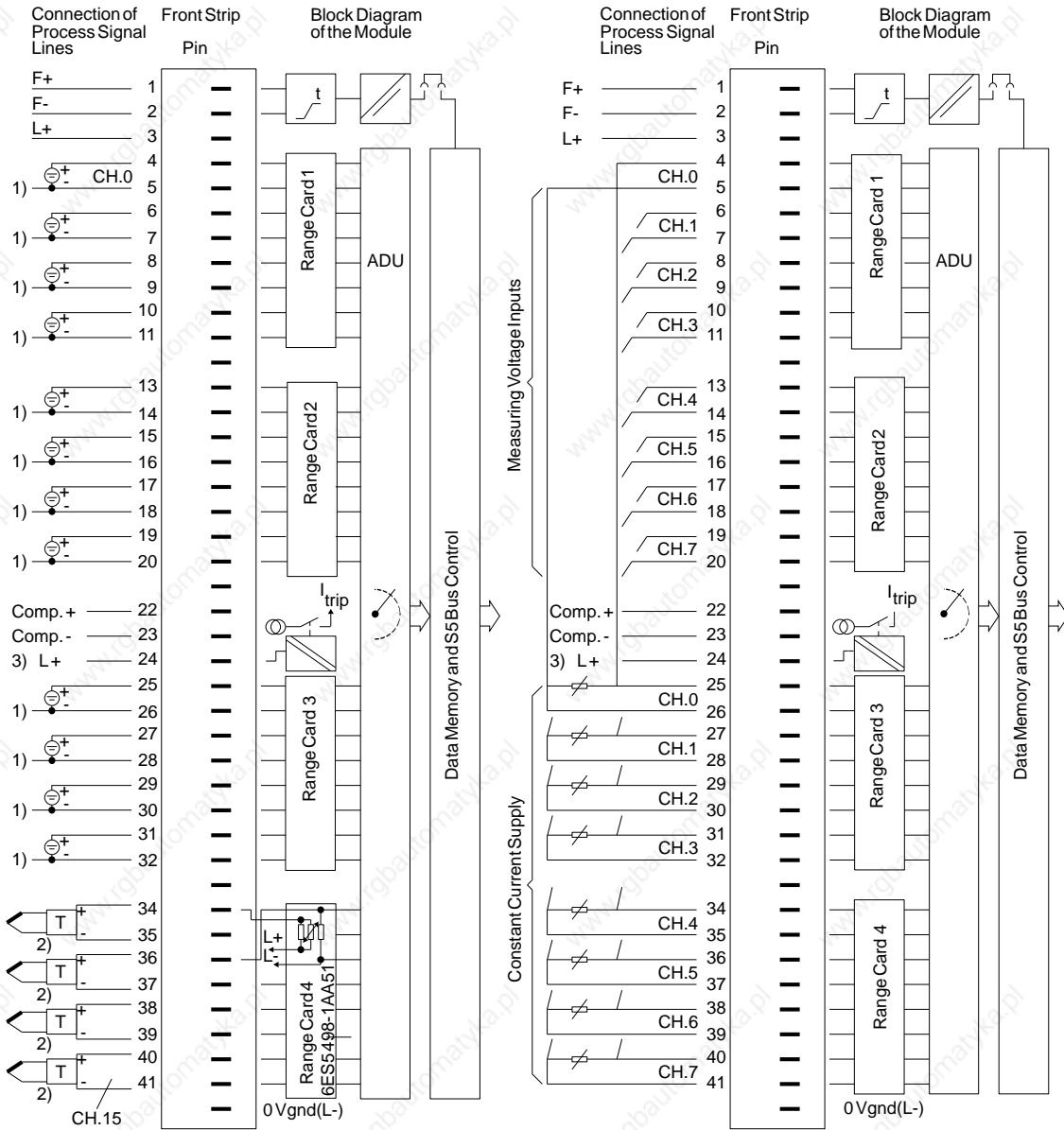

Figure 9-26 Front Connector Assignments

Two-wire transducers can only be connected in the 500 mV mode.

Connect L- to the central ground point (reference potential).

- 1) Observe permissible potential difference between sensor and reference potential of modules or between sensors.
- 2) Two-wire transducer
- 3) Only required to switch off the tripping current without broken wire detection; (0 V at common ground point with L-).

## 9.6 The 466 Analog Input Module

### 9.6.1 Design

The module is designed as a plug-in PCB for central controllers and expansion units with a backplane connector and with a blade connector to accept a plug-in front connector. You can directly connect the process signal lines to the front connector, which is available separately, with screw or crimp terminals.

### 9.6.2 Special Features of the 466 Analog Input Module

The 466 analog input module processes the digital input signals by encoding the instantaneous value; periodic system interference is therefore not suppressed.

#### Measuring range

You select the measuring ranges with a switch setting for every four channels.

### 9.6.3 Startup

#### Introduction

The mode of the 466 analog input module must be set exclusively via switches on the board. Figure 9-27 shows the designations and locations of switches on the board.

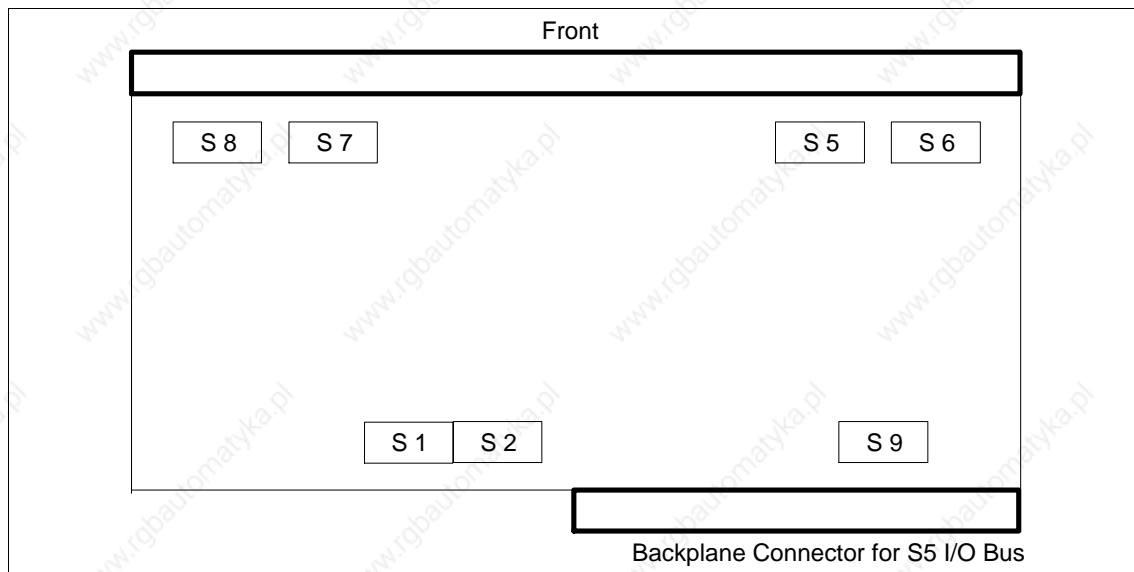

9

Figure 9-27 Locations of Mode Switches on the 466 Analog Input Module

#### Note

The following 43-pin K-type front connectors are required:

- 6x3 068 for crimp connection
- 6x3 081 for screw connection

**Setting the type of measurement**

Measurement with respect to ground/differential measurement  
 The type of measurement (with respect to ground or differential measurement) is set with switch S9. The switch settings relate to the locations on the module shown in Figure 9-27:

Type of Measurement	Switch Setting S9
Measurement with respect to ground	
Differential measurement	

**Current/voltage measurement for individual channel groups**

If you have preset differential measurement on switch S9, two channel groups of four channels each are available. You can configure each channel group separately for current or voltage measurement. You set this with switches S5, S6, S7 and S8. Switches S5 and S7 allow three settings (left, midpoint and right); switches S6 and S8 allow two settings (left and right). The switch settings relate to the locations on the module shown in Figure 9-27:

Setting the current/voltage measurement for channel group I

Channel Group I (Channels 0 to 3)	Switch S5	Switch S6
Current		
Voltage		

Setting the current/voltage measurement for channel group II

Channel Group II (Channels 4 to 7)	Switch S7	Switch S8
Current		
Voltage		

If you have preset measurement with respect to ground on switch S9, four channel groups of four channels each are available. You can configure each channel group separately for current or voltage measurement. This is set with switches S5, S6, S7 and S8. Switches S5 and S7 allow three settings (left, midpoint and right); switches S6 and S8 allow two settings (left and right). The switch settings relate to the locations on the module shown in Figure 9-27:

Setting the current/voltage measurement for channel group I

Channel Group I (Channels 0...3)	Switch S5
Current	<input type="checkbox"/> <input type="checkbox"/> <input checked="" type="checkbox"/>
Voltage	<input type="checkbox"/> <input checked="" type="checkbox"/> <input type="checkbox"/>

Setting the current/voltage measurement for channel group II

Channel Group II (Channels 4...7)	Switch S7
Current	<input type="checkbox"/> <input type="checkbox"/> <input checked="" type="checkbox"/>
Voltage	<input type="checkbox"/> <input checked="" type="checkbox"/> <input type="checkbox"/>

Setting the current/voltage measurement for channel group III

Channel Group III (Channels 8...11)	Switch S6
Current	<input checked="" type="checkbox"/> <input type="checkbox"/>
Voltage	<input type="checkbox"/> <input checked="" type="checkbox"/>

Setting the current/voltage measurement for channel group IV

Channel Group IV (Channels 12...15)	Switch S8
Current	<input checked="" type="checkbox"/> <input type="checkbox"/>
Voltage	<input type="checkbox"/> <input checked="" type="checkbox"/>

**Setting the measuring range**

The 466 analog input module has 12 measuring ranges. For each channel group (i.e. for every four inputs), you can select a range which is independent of the other channel groups. You set the ranges with switches S1 and S2.

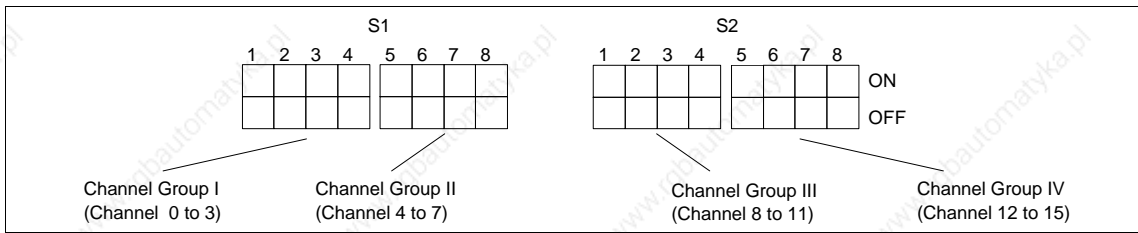

Figure 9-28 Assignment of Channel Groups to Switches S1 / S2

The same measuring range coding is valid for each channel group. Given in the following table, therefore, is the setting of the measuring range for only one channel group. The switch settings relate to the locations on the module shown in Figure 9-28.

Note that you must additionally set the type of measurement (current/voltage) with switches S5 to S8!

**Setting the measuring range for a channel group (4 channels each)**

Range	Switch Setting
0 - 20 mA	
0 - 1,25 V	
0 - 2,5 V	
0 - 5 V	
0 - 10 V	
± 20 mA	
± 1,25 V	
± 2,5 V	
± 5 V	
± 10 V	
4 - 20 mA	
1 - 5 V	

**Setting the data format**

Set the data format by means of switch S9:

- Two's complement  
12-bit two's complement representation  
(Range: 0 ... 4095 units (unipolar) or - 2048 ... + 2047 units (bipolar))
- Value and sign  
11-bit value and 1 sign bit  
(Range: 0 ... 4095 units (unipolar) or - 2048 ... + 2047 units (bipolar))
- Binary  
12-bit binary number  
(Range: 0 ... 4095 units for both unipolar and bipolar measured variables)

Data format	S9 switch setting
Two's complement	
Value and sign	
Binary	

**Setting the module start address**

Before starting up, first indicate via switch S9 whether you intend to use the 466 analog input module with a central controller (CC) or with an expansion unit (EU).

Refer to the following table:

Setting the module start address (1)

466-3LA11 module	S9 switch setting
Operation with CC	<p>The diagram shows a 2x9 grid of switch positions. The top row is labeled '1' at the left and '9' at the right. The bottom row is labeled 'ON' at the right. The switch at position 8 in the top row is filled with a black dot, and the switch at position 9 in the bottom row is filled with a black dot.</p>
Operation with IM 300/312 (EU)	<p>The diagram shows a 2x9 grid of switch positions. The top row is labeled '1' at the left and '9' at the right. The bottom row is labeled 'ON' at the right. The switch at position 8 in the bottom row is filled with a black dot, and the switch at position 9 in the top row is filled with a black dot.</p>
Operation with IM 301/310 (EU)	<p>The diagram shows a 2x9 grid of switch positions. The top row is labeled '1' at the left and '9' at the right. The bottom row is labeled 'ON' at the right. The switch at position 8 in the bottom row is filled with a black dot, and the switch at position 9 in the top row is filled with a black dot.</p>
Operation with IM 304/314 (EU)	<p>The diagram shows a 2x9 grid of switch positions. The top row is labeled '1' at the left and '9' at the right. The bottom row is labeled 'ON' at the right. The switch at position 8 in the top row is filled with a black dot, and the switch at position 9 in the top row is filled with a black dot.</p>
Operation with IM 307/317 (EU)	<p>The diagram shows a 2x9 grid of switch positions. The top row is labeled '1' at the left and '9' at the right. The bottom row is labeled 'ON' at the right. The switch at position 8 in the top row is filled with a black dot, and the switch at position 9 in the top row is filled with a black dot.</p>
Operation with IM 308/318 (EU)	<p>The diagram shows a 2x9 grid of switch positions. The top row is labeled '1' at the left and '9' at the right. The bottom row is labeled 'ON' at the right. The switch at position 8 in the top row is filled with a black dot, and the switch at position 9 in the top row is filled with a black dot.</p>

Set the exact start address of the module as shown in the following table.

Setting the module start address (2)

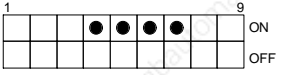
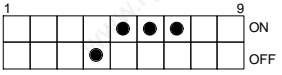
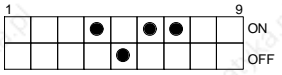
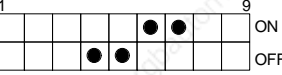
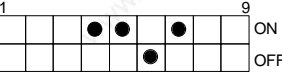
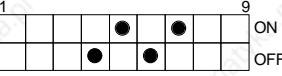
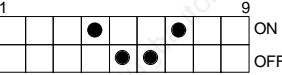
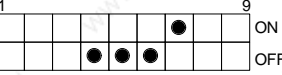
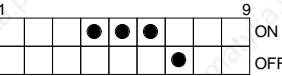
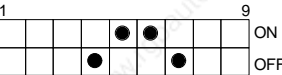
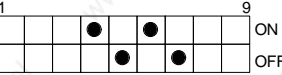
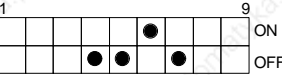
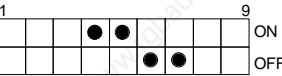
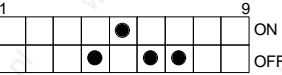
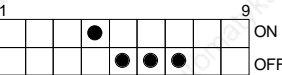
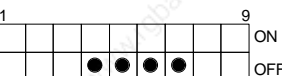
Module address	S9 switch setting
000	
016*	
032	
048*	
064	
080*	
096	
112*	
128	
144*	
160	
176*	
192	
208*	
224	
240*	

\* can only be set for differential measurement



#### 9.6.4 Removing and Inserting Modules



##### **Warning**

When removing and inserting the front connector during operation, hazardous voltages of more than 25 V AC or 60 V DC may be present at the module pins. When this is the case at the front connector, live modules may only be replaced by electrical specialists or trained personnel in such a way that the module pins are not touched.

Install an analog input/output module as follows:

Step	Action
1	Release the upper locking bar on the subrack and swivel it upwards and out.
2	Insert the module at the desired slot in the subrack and push it back in the guides.
3	Latch the module by rotating the locking pin by 90° at the lower end of the module. It must no longer be possible to pull the module forwards.
4	Engage the front connector on the support pin of the module. The width of the support pin also provides keying to prevent front connectors from being fitted to the wrong modules (e.g. front connectors with 115/230 V AC wiring cannot be plugged into analog modules).
5	Tighten the screw in the upper part of the front connector.

Remove an analog input/output module as follows:

Step	Action
1	Release the upper locking bar on the subrack and swivel it upwards and out.
2	Slacken the screw in the upper part of the front connector. This causes the front connector to be pressed out of the female connector of the module. Contacts F+ and F- of the enable input at the upper end of the front connector are thus opened first. If the enable input is active, power is removed from the outputs and the module is isolated from the S5 bus.
3	Swing the front connector out and lift it away from the support pin of the module.
4	Release the module by rotating the locking pin by 90° at the lower end of the module. You can pull the module out of the subrack with a grip with swivels outwards.

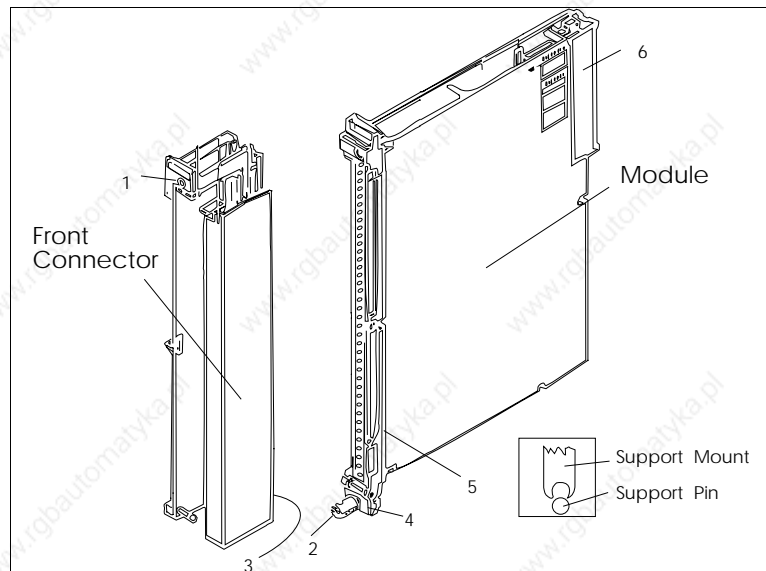

Figure 9-29 Module with Front Connector

- 1 Screw
- 2 Locking pin
- 3 Support mount
- 4 Support pin
- 5 Grip
- 6 Backplane connector

Comply with VDE Specifications 0110 and 0160 to carry out the wiring of supply and signal lines which are to be connected to the programmable controllers and front connectors of the modules.

Detailed information on cabinet assembly, cabinet ventilation and protective measures can be found in Chapter 3.

### 9.6.5 Marking of Modules and Front Connectors

For the marking of modules and front connectors, labels are supplied with the module and central controller; they are affixed as shown in Figure 9-30.

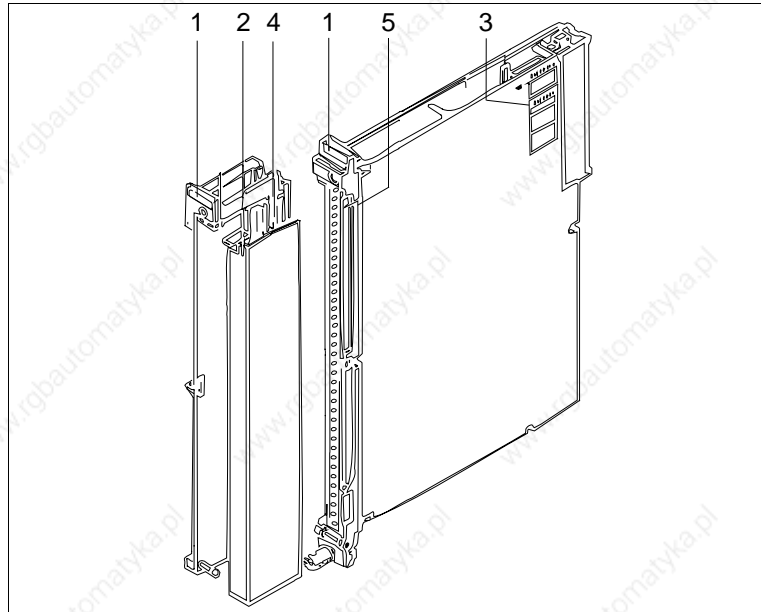

Figure 9-30 Marking and Labelling of the Module

- 1 Label with the module address under which the module is referenced by the STEP 5 program
- 2 Labelling strip with the product designation for the module; space to mark the module version and label the channels
- 3 Label with module address and marking of the required settings for the addressing switch
- 4 Labelling strip for terminal designations or connection diagrams (strip in the cover of the front connector)
- 5 Name plate

### 9.6.6

#### Connecting the Signal Lines

For connection of the signal lines, front connectors for 20 and 40 mm mounting width with crimp connection and 40 mm mounting width with screw connection are available (screwdriver blade width: 3.5 mm, maximum torque: 0.8 Nm).

Use stranded conductor to facilitate handling of the front connector. Ferrules are not required for screw connections, because the screw terminals are provided with wire protection.

When the crimp contact is inserted in the plastic body of the front connector, a click can clearly be heard. This indicates that the contact is engaged. For jumpering or to correct the wiring, you can remove the contacts with a releasing tool (see ordering information) without having to pull out the front connector.

Ferrules are not required for screw connections, because the screw terminals are provided with wire protection. You can use ferrules of 7 mm in length to DIN 46228. The maximum terminal area is  $2 \times 2.5 \text{ mm}^2$ .



#### Caution

Only extra-low voltage 60 V DC with safety separation from system voltage may be used for the 24 V DC supply and for the 24 V DC input signals. Safety separation can be implemented to the requirements of, amongst other sources, VDE 0100 Part 410/HD 384-4-41/IEC 364-4-41 (as functional extra-low voltage with safety separation) or VDE 0805/EN 60950/IEC 950 (as safety extra-low voltage SELV) or VDE 0106 Part 101.

### 9.6.7

#### **Connecting Sensors to the 466 Analog Input Module**

The connections for the 466 analog input module depend on the type of measurement (with respect to ground or differential measurement).

#### *Measurement with respect to ground*

For measurement with respect to ground, all signal lines have a common reference point. This is achieved by connecting all the M inputs in use to one point. Since this type of measurement is susceptible to interference, the signal sources should be arranged in the vicinity of the 466 analog input module.

16 channels are available; unused channels must be shorted (jumper between M+ and M-).

The channels have the following designations on the module:

Channel 0:	M0+
	M0-
Channel 1:	M1+
	M1-
	:
	:
Channel 15:	M15+
	M15-

Channels are arranged in groups of four, for which you can set separate measuring ranges:

Channel group I:	Channels 0 to 3
Channel group II:	Channels 4 to 7
Channel group III:	Channels 8 to 11
Channel group IV:	Channels 12 to 15

The following figure shows the connection of sensors to the module. For measurement with respect to ground, all the M- connection points are interconnected internally on the module.

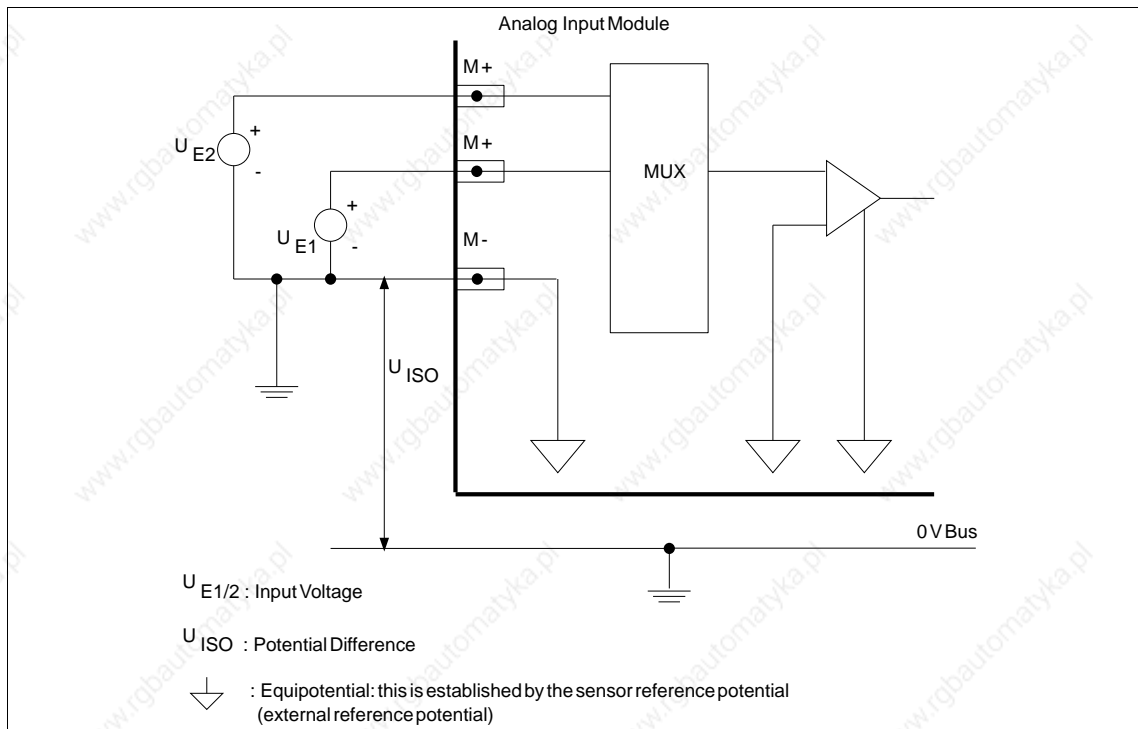

Figure 9-31 Connecting Sensors to the 466 Analog Input Module (Measurement with Respect to Ground)

### Differential measurement

The differential measurement is a method of compensating for interference on the line. Each signal source is assigned its own signal reference line. The differential measurement between signal line and signal reference line thus compensates for the interference acting on both lines.

You must also short-circuit the unused channels with this measuring method (jumper between M+ and M-).

Differential measurement is required:

- if the sensors are at different potentials;
- if various signal sources are not close to each other;
- if there is a need to measure signals with high precision,
- and when a high level of interference is expected.

The channels have the following designations on the module:

- Channel 0: M0+  
M0-
- Channel 1: M1+  
M1-
- :
- Channel 15: M15+  
M15-

Channels are arranged in groups of four, for which you can set separate measuring ranges:

- Channel group I: Channels 0 to 3
- Channel group II: Channels 4 to 7

The following figure shows the connection of sensors to the module.

You must observe the following condition:

$$U_E + U_{CM} < 12 \text{ V}$$

(i.e. the sum of the set voltage range and common-mode voltage must be less than 12 V;  
current measuring ranges correspond to a voltage of 2.5 V).

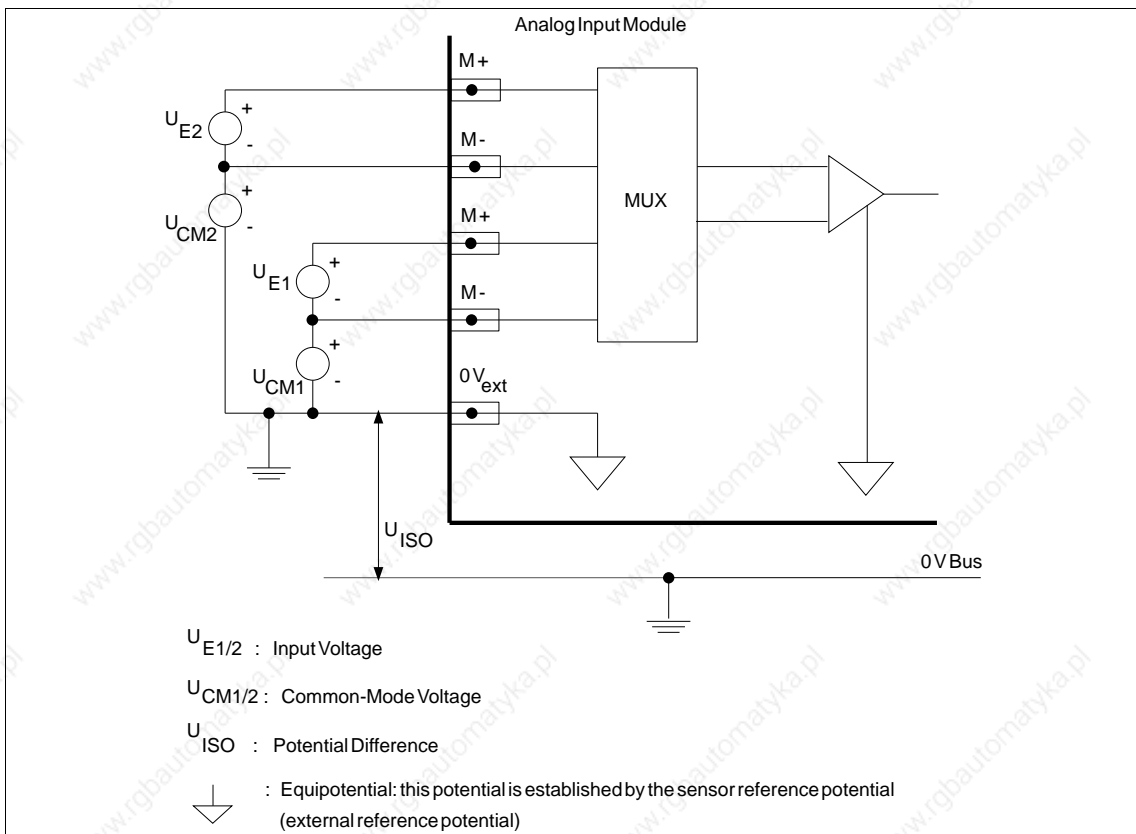

Figure 9-32 Connecting Sensors to the 466 Analog Input Module (Differential Measurement)

**9.6.8 Measured-Value Representation**

*Measured-value representation with various ranges*

After conversion, the digital result is stored in the module's RAM. The bits in both bytes have the following significance:

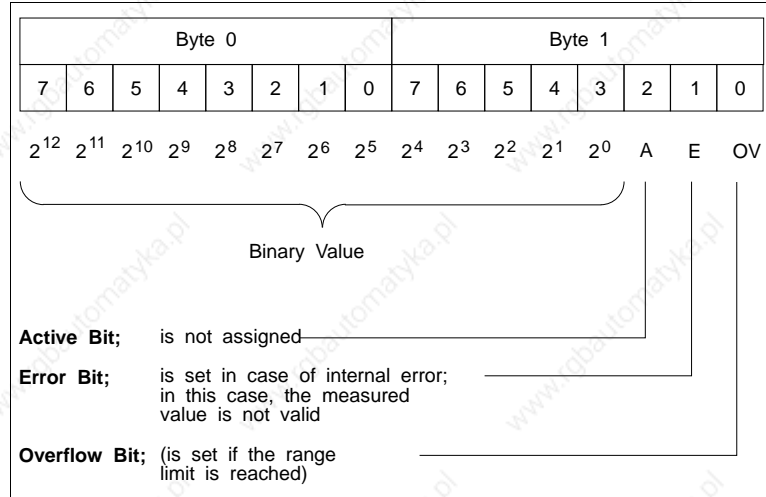

Figure 9-33 Digital Result Representation

Bits 0 to 2 in byte 1 have no influence on the measured value, they only give information on measured-value representation. The following table describes their significance in more detail.

Bit	Significance	Signal Status	Meaning of the Signal Status
OV	Overflow bit	1	Range exceeded *
E	Error bit	1	Broken wire
A	Active bit	0	Not used

\* A measuring-point overflow does not affect the overflow bits of the other channels; i.e. the measured values of unaffected channels are correct and can be evaluated.

Please note the following special features:

- Bit 7 in the high byte ( $2^{12}$ ) indicates the sign for bipolar measured-value representation (two's complement and value with sign).
- Bit 6 in the high byte ( $2^{11}$ ) is not used in the case of bipolar measured-value representation (no overrange).
- The 466 module has no overrange.
- Selective sampling is not possible with the 466 module. (Active bit is not set.)



Shown in the following tables is the representation of the measured value as a function of the selected measuring range.

Measuring range 0-20 mA,  
0-5 V and 0-10 V; unipolar

Units	Measured Value in V (0 - 5 V)	Measured Value in V (0 - 10 V)	Measured Value in mA (0 - 20 mA)	Byte 0 *								Byte 1 *									
				7 2 <sup>12</sup>	6 2 <sup>11</sup>	5 2 <sup>10</sup>	4 2 <sup>9</sup>	3 2 <sup>8</sup>	2 2 <sup>7</sup>	1 2 <sup>6</sup>	0 2 <sup>5</sup>	7 2 <sup>4</sup>	6 2 <sup>3</sup>	5 2 <sup>2</sup>	4 2 <sup>1</sup>	3 2 <sup>0</sup>	2 A	1 E	0 O		
4095	4.9988	9.9976	19.9951	0	1	1	1	1	1	1	1	1	1	1	1	1	1	1	0	0	1
4094	4.9976	9.9951	19.9902	0	1	1	1	1	1	1	1	1	1	1	1	1	1	0	0	0	0
⋮	⋮	⋮	⋮	⋮	⋮	⋮	⋮	⋮	⋮	⋮	⋮	⋮	⋮	⋮	⋮	⋮	⋮	⋮	⋮	⋮	⋮
0001	0.0012	0.0024	0.00488	0	0	0	0	0	0	0	0	0	0	0	0	0	0	1	0	0	0
0000	0.0000	0.0000	0.00000	0	0	0	0	0	0	0	0	0	0	0	0	0	0	0	0	0	1

\* Same representation for the data formats:  
two's complement, value and sign, binary representation.

A = Active bit  
E = Error bit  
O = Overflow bit

Two's complement;  
measuring range ± 5 V,  
± 20 mA and ± 10 V; bipolar

Units	Measured Value in V (± 5V)	Measured Value in V (± 10V)	Measured Value in mA (± 20 mA)	Byte 0								Byte 1									
				7 2 <sup>12</sup>	6 2 <sup>11</sup>	5 2 <sup>10</sup>	4 2 <sup>9</sup>	3 2 <sup>8</sup>	2 2 <sup>7</sup>	1 2 <sup>6</sup>	0 2 <sup>5</sup>	7 2 <sup>4</sup>	6 2 <sup>3</sup>	5 2 <sup>2</sup>	4 2 <sup>1</sup>	3 2 <sup>0</sup>	2 A	1 E	0 O		
2047	4.9976	9.9951	19.9902	0	0	1	1	1	1	1	1	1	1	1	1	1	1	1	0	0	1
2046	4.9951	9.9902	19.9804	0	0	1	1	1	1	1	1	1	1	1	1	1	1	0	0	0	0
⋮	⋮	⋮	⋮	⋮	⋮	⋮	⋮	⋮	⋮	⋮	⋮	⋮	⋮	⋮	⋮	⋮	⋮	⋮	⋮	⋮	⋮
0001	0.0024	0.0049	0.00976	0	0	0	0	0	0	0	0	0	0	0	0	0	0	1	0	0	0
0000	0.0000	0.0000	0.00000	0	0	0	0	0	0	0	0	0	0	0	0	0	0	0	0	0	0
-0001	-0.0024	-0.0049	-0.00976	1	1	1	1	1	1	1	1	1	1	1	1	1	1	1	0	0	0
⋮	⋮	⋮	⋮	⋮	⋮	⋮	⋮	⋮	⋮	⋮	⋮	⋮	⋮	⋮	⋮	⋮	⋮	⋮	⋮	⋮	⋮
-2047	-4.9976	-9.9951	-19.9902	1	1	0	0	0	0	0	0	0	0	0	0	0	0	1	0	0	0
-2048	-5.0000	-10.000	-20.0000	1	1	0	0	0	0	0	0	0	0	0	0	0	0	0	0	0	1

A = Active bit  
E = Error bit  
O = Overflow bit

Value and sign; measuring range  $\pm 5\text{ V}$ ,  $\pm 20\text{ mA}$  and  $\pm 10\text{ V}$ ; bipolar

Units	Measured Value in V ( $\pm 5\text{V}$ )	Measured Value in V ( $\pm 10\text{V}$ )	Measured Value in mA ( $\pm 20\text{ mA}$ )	Byte 0								Byte 1							
				7	6	5	4	3	2	1	0	7	6	5	4	3	2	1	0
				$2^{12}$	$2^{11}$	$2^{10}$	$2^9$	$2^8$	$2^7$	$2^6$	$2^5$	$2^4$	$2^3$	$2^2$	$2^1$	$2^0$	A	E	O
2047	4.9976	9.9951	19.9902	0	0	1	1	1	1	1	1	1	1	1	1	1	0	0	1
2046	4.9951	9.9902	19.9804	0	0	1	1	1	1	1	1	1	1	1	1	0	0	0	0
:	:	:	:				:								:				
0001	0.0024	0.0049	0.00976	0	0	0	0	0	0	0	0	0	0	0	0	1	0	0	0
0000	0.0000	0.0000	0.00000	0	0	0	0	0	0	0	0	0	0	0	0	0	0	0	0
-0001	-0.0024	-0.0049	-0.00976	1	0	0	0	0	0	0	0	0	0	0	0	1	0	0	0
:	:	:	:				:								:				
-2047	-4.9976	-9.9951	-19.9902	1	0	1	1	1	1	1	1	1	1	1	1	1	0	0	0
-2048	-5.0000	-10.000	-20.0000	1	1	0	0	0	0	0	0	0	0	0	0	0	0	0	1

A = Active bit  
E = Error bit  
O = Overflow bit

Binary; measuring range  $\pm 5\text{ V}$ ,  $\pm 20\text{ mA}$  and  $\pm 10\text{ V}$ ; bipolar

Units	Measured Value in V ( $\pm 5\text{V}$ )	Measured Value in V ( $\pm 10\text{V}$ )	Measured Value in mA ( $\pm 20\text{ mA}$ )	Byte 0								Byte 1							
				7	6	5	4	3	2	1	0	7	6	5	4	3	2	1	0
				$2^{12}$	$2^{11}$	$2^{10}$	$2^9$	$2^8$	$2^7$	$2^6$	$2^5$	$2^4$	$2^3$	$2^2$	$2^1$	$2^0$	A	E	O
4095	4.9976	9.9951	19.9902	0	1	1	1	1	1	1	1	1	1	1	1	1	0	0	1
4094	4.9951	9.9902	19.9804	0	1	1	1	1	1	1	1	1	1	1	1	0	0	0	0
:	:	:	:				:								:				
2049	0.0024	0.0049	0.00976	0	1	0	0	0	0	0	0	0	0	0	0	1	0	0	0
2048	0.0000	0.0000	0.00000	0	1	0	0	0	0	0	0	0	0	0	0	0	0	0	0
2047	-0.0024	-0.0049	-0.00976	0	0	1	1	1	1	1	1	1	1	1	1	1	0	0	0
:	:	:	:				:								:				
0001	-4.9976	-9.9951	-19.9902	0	0	0	0	0	0	0	0	0	0	0	0	1	0	0	0
0000	-5.0000	-10.000	-20.0000	0	0	0	0	0	0	0	0	0	0	0	0	0	0	0	1

A = Active bit  
E = Error bit  
O = Overflow bit



Measuring range 0-1.25 V and 0-2.5 V; unipolar

Units	Measured Value in V (0 - 1.25 V)	Measured Value in V (0 - 2.5 V)	Byte 0 *								Byte 1 *							
			7	6	5	4	3	2	1	0	7	6	5	4	3	2	1	0
			$2^{12}$	$2^{11}$	$2^{10}$	$2^9$	$2^8$	$2^7$	$2^6$	$2^5$	$2^4$	$2^3$	$2^2$	$2^1$	$2^0$	A	E	O
4095	1.2497	2.4994	0	1	1	1	1	1	1	1	1	1	1	1	1	0	0	1
4094	1.2494	2.4988	0	1	1	1	1	1	1	1	1	1	1	1	0	0	0	0
:	:	:				:								:				
0001	0.0003	0.0006	0	0	0	0	0	0	0	0	0	0	0	0	1	0	0	0
0000	0.0000	0.0000	0	0	0	0	0	0	0	0	0	0	0	0	0	0	0	1

\* Same representation for the data formats:  
two's complement, value and sign, binary representation.

A = Active bit  
E = Error bit  
O = Overflow bit

Two's complement; measuring range  $\pm 1.25$  V and  $\pm 2.5$  V; bipolar

Units	Measured Value in V ( $\pm 1.25$ V)	Measured Value in V ( $\pm 2.5$ V)	Byte 0								Byte 1							
			7 2 <sup>12</sup>	6 2 <sup>11</sup>	5 2 <sup>10</sup>	4 2 <sup>9</sup>	3 2 <sup>8</sup>	2 2 <sup>7</sup>	1 2 <sup>6</sup>	0 2 <sup>5</sup>	7 2 <sup>4</sup>	6 2 <sup>3</sup>	5 2 <sup>2</sup>	4 2 <sup>1</sup>	3 2 <sup>0</sup>	2 A	1 E	0 O
2047	1.2494	2.4988	0	0	1	1	1	1	1	1	1	1	1	1	1	0	0	1
2046	1.2488	2.4975	0	0	1	1	1	1	1	1	1	1	1	0	0	0	0	
:	:	:	:								:							
0001	0.0006	0.0012	0	0	0	0	0	0	0	0	0	0	0	1	0	0	0	
0000	0.0000	0.0000	0	0	0	0	0	0	0	0	0	0	0	0	0	0	0	
-0001	-0.0006	-0.0012	1	1	1	1	1	1	1	1	1	1	1	1	0	0	0	
:	:	:	:								:							
-2047	-1.2494	-2.4988	1	1	0	0	0	0	0	0	0	0	0	1	0	0	0	
-2048	-1.2500	-2.5000	1	1	0	0	0	0	0	0	0	0	0	0	0	0	1	

A = Active bit  
E = Error bit  
O = Overflow bit

Value and sign; measuring range  $\pm 1.25$  V and  $\pm 2.5$  V; bipolar

Units	Measured Value in V ( $\pm 1.25$ V)	Measured Value in V ( $\pm 2.5$ V)	Byte 0								Byte 1							
			7 2 <sup>12</sup>	6 2 <sup>11</sup>	5 2 <sup>10</sup>	4 2 <sup>9</sup>	3 2 <sup>8</sup>	2 2 <sup>7</sup>	1 2 <sup>6</sup>	0 2 <sup>5</sup>	7 2 <sup>4</sup>	6 2 <sup>3</sup>	5 2 <sup>2</sup>	4 2 <sup>1</sup>	3 2 <sup>0</sup>	2 A	1 E	0 O
2047	1.2494	2.4988	0	0	1	1	1	1	1	1	1	1	1	1	1	0	0	1
2046	1.2488	2.4975	0	0	1	1	1	1	1	1	1	1	1	0	0	0	0	
:	:	:	:								:							
0001	0.0006	0.0012	0	0	0	0	0	0	0	0	0	0	0	1	0	0	0	
0000	0.0000	0.0000	0	0	0	0	0	0	0	0	0	0	0	0	0	0	0	
-0001	-0.0006	-0.0012	1	0	0	0	0	0	0	0	0	0	0	0	0	0	0	
:	:	:	:								:							
-2047	-1.2494	-2.4988	1	0	1	1	1	1	1	1	1	1	1	1	0	0	0	
-2048	-1.2500	-2.5000	1	1	0	0	0	0	0	0	0	0	0	0	0	0	1	

A = Active bit  
E = Error bit  
O = Overflow bit

Binary; measuring range  $\pm 1.25$  V and  $\pm 2.5$  V; bipolar

Units	Measured Value in V ( $\pm 1.25$ V)	Measured Value in V ( $\pm 2.5$ V)	Byte 0 *								Byte 1 *							
			7 2 <sup>12</sup>	6 2 <sup>11</sup>	5 2 <sup>10</sup>	4 2 <sup>9</sup>	3 2 <sup>8</sup>	2 2 <sup>7</sup>	1 2 <sup>6</sup>	0 2 <sup>5</sup>	7 2 <sup>4</sup>	6 2 <sup>3</sup>	5 2 <sup>2</sup>	4 2 <sup>1</sup>	3 2 <sup>0</sup>	2 A	1 E	0 O
4095	1.2494	2.4988	0	1	1	1	1	1	1	1	1	1	1	1	1	0	0	1
4094	1.2488	2.4975	0	1	1	1	1	1	1	1	1	1	1	0	0	0	0	
:	:	:	:								:							
2049	0.0006	0.0012	0	1	0	0	0	0	0	0	0	0	0	1	0	0	0	
2048	0.0000	0.0000	0	1	0	0	0	0	0	0	0	0	0	0	0	0	0	
2047	-0.0006	-0.0012	0	0	1	1	1	1	1	1	1	1	1	1	0	0	0	
:	:	:	:								:							
0001	-1.2494	-2.4988	0	0	0	0	0	0	0	0	0	0	0	1	0	0	0	
0000	-1.2500	-2.5000	0	0	0	0	0	0	0	0	0	0	0	0	0	0	1	

\* Same representation for the data formats:  
two's complement, value and sign, binary representation.

A = Active bit  
E = Error bit  
O = Overflow bit

## 9.6.9

## Technical Specifications

## 6ES5 466-3LA11 Analog Input Module

Input ranges	0-20 mA; 4-20 mA; $\pm 20$ mA; 0-1.25 V; 0-2.5 V; 0-5 V; 1-5 V; 0-10 V; $\pm 1.25$ V; $\pm 2.5$ V; $\pm 5$ V; $\pm 10$ V
Number of inputs	16 single or 8 differential inputs in groups of 4 or 2 channels (selectable) voltage or current measurement
Measuring principle	Instantaneous value encoding
Conversion time	25 $\mu$ s typical (per channel)
Isolation	Yes
Permissible isolation between sensor ref. potential and central ground point	25 V AC/60 V DC max.
Supply voltage internal external	+ 5 V +/- 5 % None
Current consumption, internal	0.7 A typical
Encoding time per measured value	250 $\mu$ s
Duration of cyclic sampling (cycle time) for 8 measured values for 16 measured values	2 ms max. 4 ms max.
Input resistance voltage measuring range current measuring range	$\geq 10$ M $\Omega$ 125 $\Omega$
Type of circuit for sensors	Two-wire circuit
Digital representation of the input signal	Selectable, following types of representation: - 12-bit two's complement - 11-bit value with sign - 12-bit binary
Max. permissible input voltage without destruction	$\pm 30$ V max. (static) or $\pm 75$ V (pulse for 1 ms max. and duty ratio 1:20)
Interference voltage suppression common-mode interference ( $V_{pp} = 1$ V)	70 dB min.
Basic error limits - voltage ranges except for 0-1.25 V; $\pm 1.25$ V - current ranges and 0-1.25 V; $\pm 1.25$ V	0.1 % 0.2 %

## The 466 Analog Input Module

---

Operational error limit (0 °C ... 60 °C) - voltage ranges except for 0-1.25 V, $\pm 1.25$ V - current ranges and 0-1.25 V, $\pm 1.25$ V	0.2 % 0.2 %
Error signal for overflow for internal error	Yes (overflow bit set) Yes (error bit (= E bit) set)
Single error linearity tolerance polarity reversal error	0.02 % 0.05 % 0.05 %
Temperature error	0.005 %/K
Insulation rating	To VDE 0160
Line length - shielded	200 m max.
Front connector	43-way
Power dissipation of module	3.5 W typical
Weight	Approx. 0.4 kg
Rated insulation voltage (between channels and ground point) tested at	500 V

Front connector assignments

Voltage-to-ground measurement

Differential measurement

Front Strip		Front Strip	
Pin		Pin	
1	—	1	—
2	M0+	2	M0+
3	M0-	3	Mext
4	M8-	4	Mext
5	M8+	5	M0-
6	—	6	—
7	M1+	7	M1+
8	M1-	8	Mext
9	M9-	9	Mext
10	M9+	10	M1-
11	—	11	—
12	M2+	12	M2+
13	M2-	13	Mext
14	M10-	14	Mext
15	M10+	15	M2-
16	—	16	—
17	M3+	17	M3+
18	M3-	18	Mext
19	M11-	19	Mext
20	M11+	20	M3-
21	—	21	—
22	—	22	—
23	—	23	—
24	M4+	24	M4+
25	M4-	25	Mext
26	M12-	26	Mext
27	M12+	27	M4-
28	—	28	—
29	M5+	29	M5+
30	M5-	30	Mext
31	M13-	31	Mext
32	M13+	32	M5-
33	—	33	—
34	M6+	34	M6+
35	M6-	35	Mext
36	M14-	36	Mext
37	M14+	37	M6-
38	—	38	—
39	M7+	39	M7+
40	M7-	40	Mext
41	M15-	41	Mext
42	M15+	42	M7-

Figure 9-34 Front Connector Assignments

## 9.7 The 470 Analog Output Module

### 9.7.1 Design

The module is designed as a plug-in PCB for central controllers and expansion units with a backplane connector and with a blade connector to accept a plug-in front connector. You can directly connect the process signal lines to the front connector, which is available separately, with screw or crimp terminals.

#### Addressing switch, mode switches

Situated on each module is an addressing switch with six rockers to set the module address.

The modules are protected by covers on both sides.

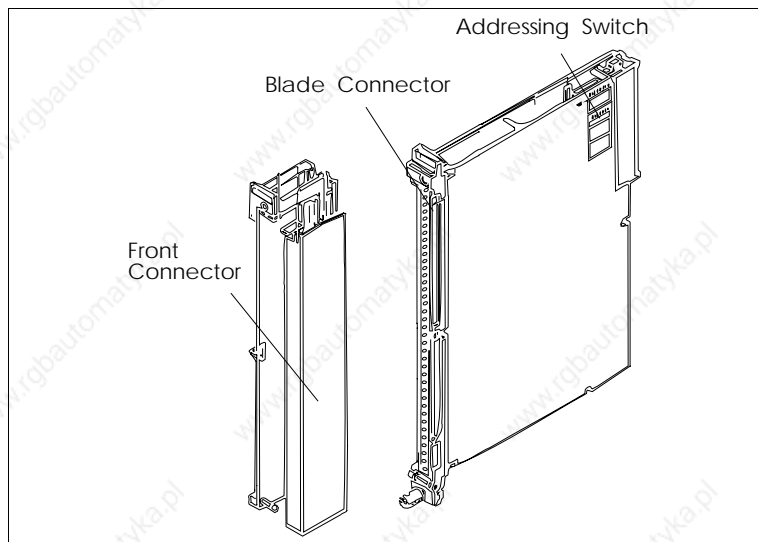

Figure 9-34 Analog Output Module

9

### 9.7.2

#### Function of the Enable Input

The 470 module has an enable circuit. You can use the enable inputs to switch off individual modules whilst the PLC is in operation. This means that:

- The module can no longer be addressed by the user program.
- On analog output modules, the last analog value to be output is retained.

Modules which are switched off can be removed or inserted during operation. If this is not necessary, operate the module with the enable input switched off.

**Enable input**

The enable circuit requires an external 24 V voltage at enable inputs F+/F- in the front connector. If there is no voltage at F+/F-, the modules will not acknowledge.

When the front connector is swivelled away from the front strip of the module, the supply of power to the enable input is interrupted, i.e. the module is switched off and can no longer be addressed by the user program: a timeout (QVZ) occurs in the CC.

**Switching off the enable input**

The -4Ux12-type modules additionally offer the facility for changing the enable mode. The modules have a jumper accessible from above in the vicinity of the addressing switch.

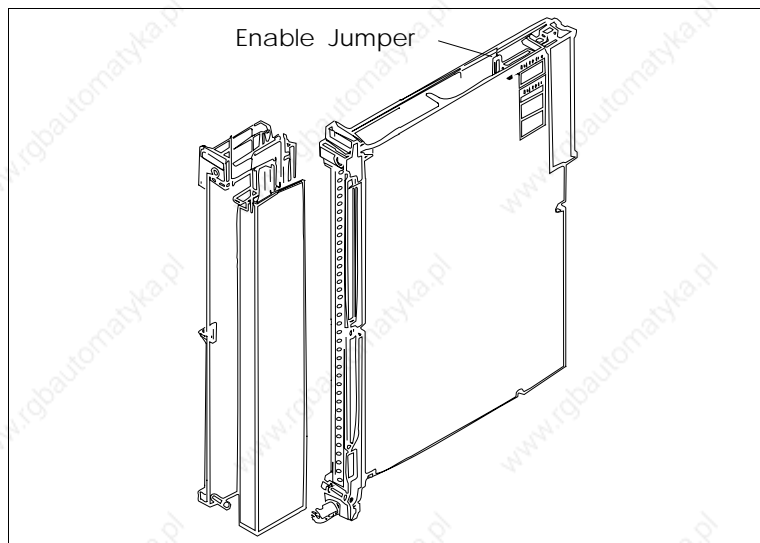

Figure 9-35 Enable Input and Enable Jumper

Jumper inserted: Enable input (F+/F-) active (factory setting)  
Jumper open: Enable input (F+/F-) switched off

**Examples of functioning of the enable inputs:**

- To switch off individual subprocesses, i.e. outputs of various modules can be operated from a common load supply and yet activated separately.
- The load voltage of individual modules can be monitored without additional circuitry. Any reactions to failure of the load voltage can be programmed in the QVZ (timeout) organization block.



**Configuring**

You must observe the following when configuring systems:

Switching on	At the latest 100 ms after power-up of the PLC, the voltage must be present at the enable inputs of the I/O modules.
Switching off	When the PLC has been switched off, the voltage at the enable inputs of the I/O modules must still be present as long as the internal 5 V voltage is present. However, you must ensure that the 24 V load supply for analog output modules is switched off together with the PLC. If the supply voltage is still present at the modules and the PLC is switched off, the output values can drift. (The analog holding elements for the outputs will no longer be refreshed with the current value, because there is no 5 V supply to the modules from the bus.)

**Switching off the CC**

You should observe the following instructions for switching off CCs and equipment for supplying power to the enable inputs.

**Separate or common shutdown of the CC/EU and load power supply**

When there is a need to switch off the load power supply separately without affecting the enabling of modules, there are the following possibilities for producing the enable voltage. These exist even when the load power supply is used without an additional capacitor and common shutdown.

- **230 V AC supply for CC/EU and load power supply**

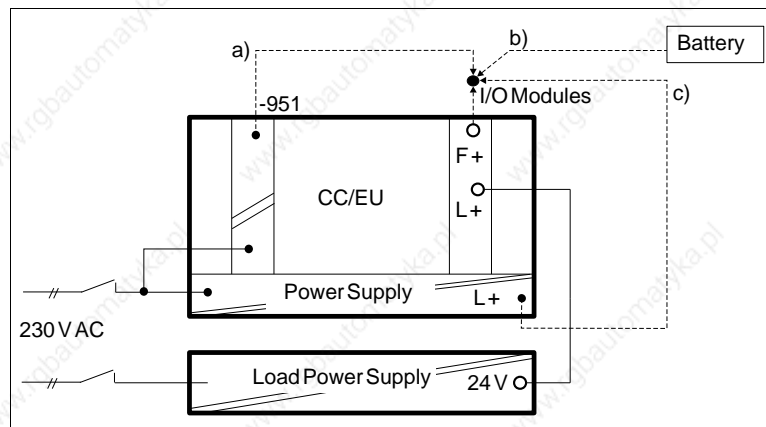

Supply for the enable inputs from:

- 6ES5 951-4LB11 load power supply
- Battery
- Terminals for 24 V on the front plate of the power supply

• 24 V supply for CC/EU and I/Os



Supply for the enable inputs from:

- a) Battery
- b) Terminals for 24 V on the front plate of the power supply

*Common shutdown of the CC/EU and load power supply with a 230 V AC supply*

Proper functioning is ensured if the 24 V load power supply has an output capacitance of at least 4700  $\mu\text{F}$  per 10 A of load current. Other units which do not meet this condition can be adapted to this requirement by connecting a 10000  $\mu\text{F}/40\text{ V}$  capacitor in parallel.







**Addressing for cyclic/selective sampling**

However, analog input modules and analog output modules may be given the same address with cyclic sampling because they are distinguished by the user program. This is not possible with selective sampling.

For cyclic sampling, you can address the module in the address range from 0 to 255, and for selective sampling from 128 to 255. For selective sampling, you can also use the address range from 0 to 127 after appropriate programming in DB 1 of the user program.

**Example**

On an analog output module with 8 outputs with start address 144 (IB 144 = output byte 144), output channel 7 is to be scanned by the program.

Step	Action
1	Affix the self-adhesive label with address 144 on the free field under the addressing switch on the module. ADB 4 and ADB 7 are marked on the label.
2	Press the appropriate rockers of the addressing switch down on the side marked by a dot on the module cover. Set the other rockers to the opposite setting. This sets the start address of the module. ADB 4 and ADB 7 results in $2^4 + 2^7 = 16 + 128 = 144$
3	Enter the address $144 + 7 \times 2 = 158$ in the program for output channel 7.

### 9.7.5 Removing and Inserting Modules



#### **Warning**

When removing and inserting the front connector during operation, hazardous voltages of more than 25 V AC or 60 V DC may be present at the module pins. When this is the case at the front connector, live modules may only be replaced by electrical specialists or trained personnel in such a way that the module pins are not touched.

During operation, the front connector and module must not be removed or inserted without the enable jumper or active enable circuit.

Install an analog input/output module as follows:

Step	Action
1	Release the upper locking bar on the subrack and swivel it upwards and out.
2	Insert the module at the desired slot in the subrack and push it back in the guides.
3	Latch the module by rotating the locking pin by 90° at the lower end of the module. It must no longer be possible to pull the module forwards.
4	Engage the front connector on the support pin of the module. The width of the support pin also provides keying to prevent front connectors from being fitted to the wrong modules (e.g. front connectors with 115/230 V AC wiring cannot be plugged into analog modules).
5	Tighten the screw in the upper part of the front connector.

Remove an analog input/output module as follows:

Step	Action
1	Release the upper locking bar on the subrack and swivel it upwards and out.
2	Slacken the screw in the upper part of the front connector. This causes the front connector to be pressed out of the female connector of the module. Contacts F+ and F- of the enable input at the upper end of the front connector are thus opened first. If the enable input is active, power is removed from the outputs and the module is isolated from the S5 bus.
3	Swing the front connector out and lift it away from the support pin of the module.
4	Release the module by rotating the locking pin by 90° at the lower end of the module. You can pull the module out of the subrack with a grip with swivels outwards.

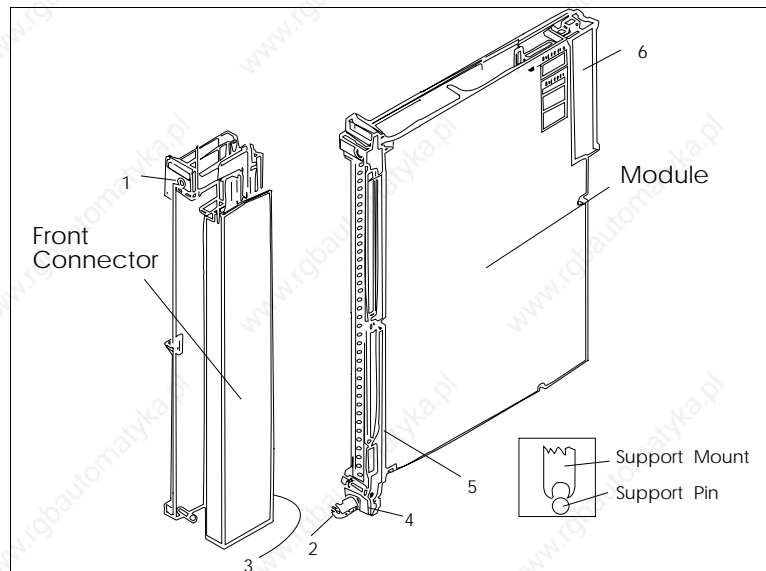

Figure 9-37 Module with Front Connector

- 1 Screw
- 2 Locking pin
- 3 Support mount
- 4 Support pin
- 5 Grip
- 6 Backplane connector

Comply with VDE Specifications 0110 and 0160 to carry out the wiring of supply and signal lines which are to be connected to the programmable controllers and front connectors of the modules.

Detailed information on cabinet assembly, cabinet ventilation and protective measures can be found in Chapter 3.

### 9.7.6 Marking of Modules and Front Connectors

For the marking of modules and front connectors, labels are supplied with the module and central controller; they are affixed as shown in Figure 9-38.

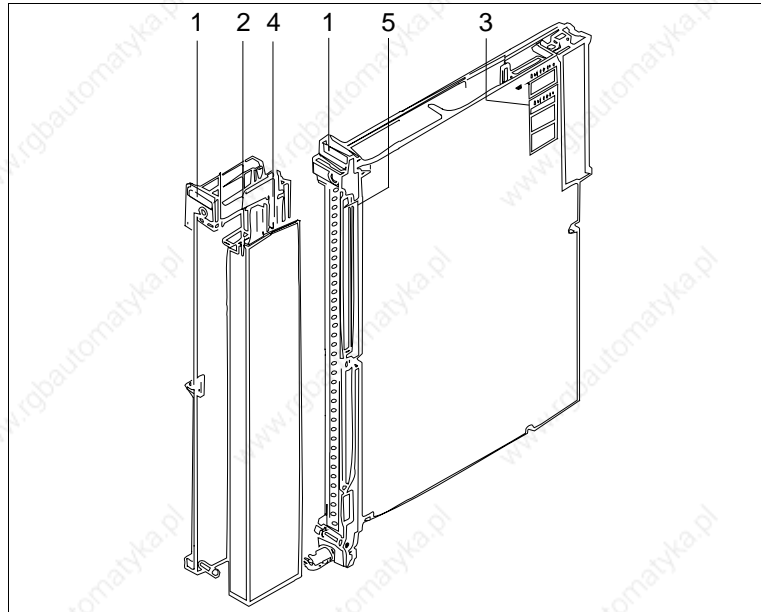

Figure 9-38 Marking and Labelling of Modules

- 1 Label with the module address under which the module is referenced by the STEP 5 program
- 2 Labelling strip with the product designation for the module; space to mark the module version and label the channels
- 3 Label with module address and marking of the required settings for the addressing switch
- 4 Labelling strip for terminal designations or connection diagrams (strip in the cover of the front connector)
- 5 Name plate



9.7.7

**Connecting the Signal Lines**

For connection of the signal lines, front connectors for 20 and 40 mm mounting width with crimp connection and 40 mm mounting width with screw connection are available (screwdriver blade width: 3.5 mm, maximum torque: 0.8 Nm).

Use stranded conductor to facilitate handling of the front connector. Ferrules are not required for screw connections, because the screw terminals are provided with wire protection.

When the crimp contact is inserted in the plastic body of the front connector, a click can clearly be heard. This indicates that the contact is engaged. For jumpering or to correct the wiring, you can remove the contacts with a releasing tool (see ordering information) without having to pull out the front connector.

Ferrules are not required for screw connections, because the screw terminals are provided with wire protection. You can use ferrules of 7 mm in length to DIN 46228. The maximum terminal area is 2 x 2.5 mm<sup>2</sup>.

Terminal Type	Connector Type 6ES 497-	Max. No. of Contacts	Cross-Section		Connector for Rated Voltage	Mounting Width of Module
			Signal or Supply Conductor	Aux. Jumper in Connector <sup>1)</sup>		
Crimp connection	-4UA12 <sup>2)</sup>	42	0.5 mm <sup>2</sup>	0.5 mm <sup>2</sup>	5 to 60 V DC	20 mm Operation with fan
	-4UA22 <sup>2)</sup>	42	0.5 mm <sup>2</sup>	0.5 mm <sup>2</sup>	5 to 60 V DC	40 mm
Screw connection	-4UB12	42	0.5 to 2.5 mm <sup>2</sup>	0.5 to 1.0 mm <sup>2</sup>	5 to 60 V DC	40 mm Operation without fan
	-4UB31	42	0.5 to 1.5 mm <sup>2</sup>	0.5 to 1.0 mm <sup>2</sup>	5 to 60 V DC	20 mm

<sup>1)</sup> To multiply the supply and 0 V ground terminals, and to connect the enable input

<sup>2)</sup> The crimp contacts must be ordered separately for these types of connector.



**Caution**

Only extra-low voltage 60 V DC with safety separation from system voltage may be used for the 24 V DC supply and for the 24 V DC input signals. Safety separation can be implemented to the requirements of, amongst other sources, VDE 0100 Part 410/HD 384-4-41/IEC 364-4-41 (as functional extra-low voltage with safety separation) or VDE 0805/EN 60950/IEC 950 (as safety extra-low voltage SELV) or VDE 0106 Part 101.

9.7.8

**Connecting Loads to the 470 Analog Output Module**

The voltage at the load is measured at a high resistance via the sensor lines (S+/S-) of voltage output QV, so that voltage drops on the load lines do not falsify the load voltages. Lines S+(x) and S-(x) should therefore be directly connected to the load (four-wire circuit). The voltage drops on the lines from QV(x) to the load and from the load to M<sub>ANA</sub> must not exceed 3 V.

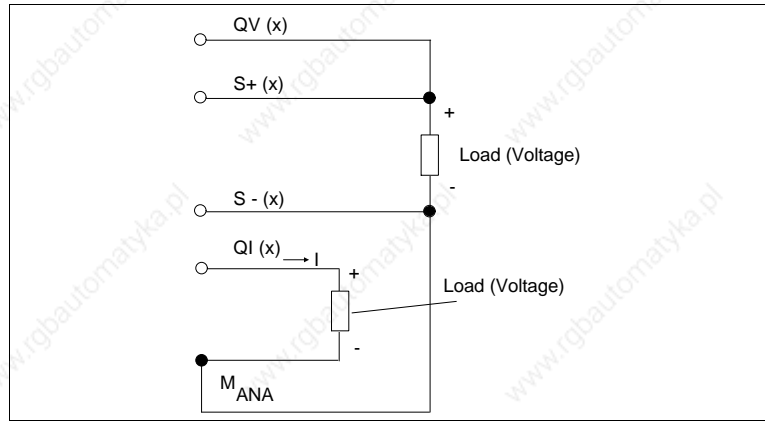

Figure 9-39 Connecting Loads

- QV(x) Voltage output, voltage on Channels 0 to 7
- QI(x) Current output, current on Channels 0 to 7
- S+(x) Sensor line (+) for Channels 0 to 7
- S-(x) Sensor line (-) for Channels 0 to 7
- M<sub>ANA</sub> Ground terminal for the analog section

*Connecting loads to current and voltage outputs*

When current and voltage outputs are used on the 470-4UA/-4UC... analog output modules, connect the loads as follows:

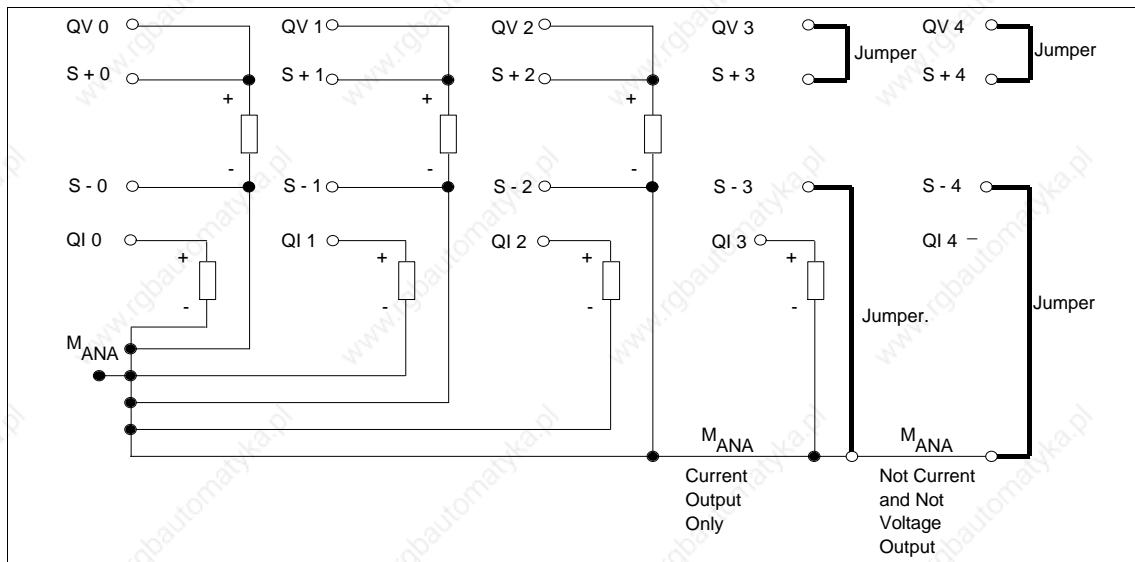

Figure 9-40 Connecting Loads

If, with voltage outputs, an excessively great voltage drop must be expected on the lines to the load, you must route the sensor lines S+(x) and S-(x) to the load.

When voltage outputs are not used, the S+(x) sensor lines in the front connector must be connected to the corresponding voltage output terminals (QV(x)) with wire jumpers. The S-(x) sensor lines must be connected to M<sub>ANA</sub> with wire jumpers.

You must also insert the same jumpers if only current outputs are used. Unused current outputs may remain open.

The maximum load for the current outputs including line resistance, must not exceed 300 ohms.

**Connecting loads to voltage outputs**

The voltage outputs of the 470 analog output module are wired as follows:

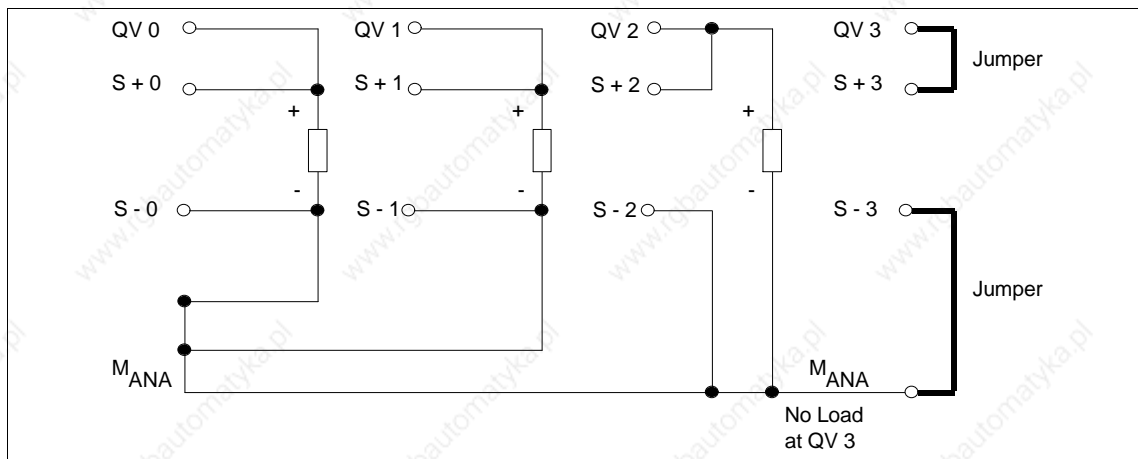

Figure 9-41 Connecting Loads

**Four-wire circuit**

The S+(x) and S-(x) sensor lines must be routed to the load (four-wire circuit) if the voltage drop on the lines to the load is not negligible. The common connection for the voltage outputs is M<sub>ANA</sub>. If the voltage drop on lines to the load is negligible, you can connect S+(x) to QV(x) and S-(x) to M<sub>ANA</sub> in the front connector.

When voltage outputs are unused, you must insert jumpers in the front connector, e.g. QV(3) to S+(3) and S-(3) to M<sub>ANA</sub> for unused voltage output 3 (see previous section).

### 9.7.9 Measured-Value Representation

*Digital measured-value  
representation as two's  
complement*

Units	Output Voltage or Current of the 470 Analog Output Module				Byte 0								Byte 1							
	-4UA/B12	-4UA12	-4UC12		7 2 <sup>11</sup>	6 2 <sup>10</sup>	5 2 <sup>9</sup>	4 2 <sup>8</sup>	3 2 <sup>7</sup>	2 2 <sup>6</sup>	1 2 <sup>5</sup>	0 2 <sup>4</sup>	7 2 <sup>3</sup>	6 2 <sup>2</sup>	5 2 <sup>1</sup>	4 2 <sup>0</sup>	3 x	2 x	1 x	0 x
1280	12.5 V	25.0 mA	6.0 V	24.0 mA	0	1	0	1	0	0	0	0	0	0	0	0	Ovrange			
1025	10.0098 V	20.0195 mA	5.004 V	20.016 mA	0	1	0	0	0	0	0	0	0	0	0	1				
1024	10.0 V	20.0 mA	5.0 V	20.0 mA	0	1	0	0	0	0	0	0	0	0	0	0				
1023	9.99 V	19.98 mA	4.995 V	19.98 mA	0	0	1	1	1	1	1	1	1	1	1	1				
512	5.0 V	10.0 mA	3.0 V	12.0 mA	0	0	1	0	0	0	0	0	0	0	0	0				
256	2.5 V	5.0 mA	2.0 V	8.0 mA	0	0	0	1	0	0	0	0	0	0	0	0				
128	1.25 V	2.5 mA	1.5 V	6.0 mA	0	0	0	0	1	0	0	0	0	0	0	0				
64	0.625 V	1.25 mA	1.25 V	5.0 mA	0	0	0	0	0	1	0	0	0	0	0	0				
1	9.8 mV	19.5 μA	1.004 V	4.016 mA	0	0	0	0	0	0	0	0	0	0	0	1				
0	0 V	0 mA	1.0 V	4.0 mA	0	0	0	0	0	0	0	0	0	0	0	0	Rated range			
- 1	- 9.8 mV	0 mA	0.996 V	3.984 mA	1	1	1	1	1	1	1	1	1	1	1	1				
- 64	- 0.625 V	0 mA	0.75 V	3.0 mA	1	1	1	1	1	1	0	0	0	0	0	0				
- 128	- 1.25 V	0 mA	0.5 V	2.0 mA	1	1	1	1	1	0	0	0	0	0	0	0				
- 256	- 2.5 V	0 mA	0 V	0 mA	1	1	1	1	0	0	0	0	0	0	0	0				
- 512	- 5.0 V	0 mA	- 1 V	0 mA	1	1	1	0	0	0	0	0	0	0	0	0				
-1024	- 10.0 V	0 mA	- 3.0 V	0 mA	1	1	0	0	0	0	0	0	0	0	0	0				
-1025	-10.0098V	0 mA	- 3.004V	0 mA	1	0	1	1	1	1	1	1	1	1	1	1	Ovrange			
-1280	-12.5 V	0 mA	- 5.0 V	0 mA	1	0	1	1	0	0	0	0	0	0	0	0				

## 9.7.10

## Technical Specifications

6ES5 470-4UA12, 6ES5 470-4UB12 and 6ES5 470-4UC12  
Analog Output Modules

Rated output ranges - 6ES5 470-4UA12  - 6ES5 470-4UB12 - 6ES5 470-4UC12	0 to $\pm 10$ V and 0 to 20 mA parallel for $\pm 1024$ units $\pm 10$ V for $\pm 1024$ units 1 to 5 V and 4 to 20 mA parallel for 0 to 1024 units
Number of outputs	8 voltage and current outputs each, no-load and short-circuit-proof
Isolation	Yes, 8 outputs with respect to $M_{ext}$
Measured value representation	12-bit (two's complement)
Linearity in the range of $\pm 1024$ units	$\pm 2$ LSB = $\pm 0.2$ %
Operational error limits (0 to 60 °C)	$\pm 0.6$ %
Permissible overrange	approx. 25 % ( $\pm 1024$ to $\pm 1272$ units)
Fault current at voltage output	approx. 25 mA
No-load voltage at current output	18 V max.
Output current at voltage output	3 mA max.
Capacitive load including line capacity for -4UA12 from version 4	100 nF max. 1 $\mu$ F max.
Delay between data transfer and analog value output	$\leq 1$ ms
Load impedance - at voltage output - at current output	$\geq 3.3$ k $\Omega$ $\leq 300$ $\Omega$
Temperature coefficient for voltage and current outputs	$1 \times 10^{-4}/K$
Permissible voltage drop on voltage output lines	$\pm 0.3$ V at maximum output voltage
Power supply - Digital section from system bus - Analog section from load voltage - Enabling for module, F+/F-	5 V $\pm 5$ %; approx. 250 mA 24 V; 200 to 400 mA 24 V; approx. 7 mA
Permissible potential difference between reference potential of the load and housing ( $U_{CM}$ )	25 V AC/60 V DC max.
Voltage test to VDE 0160	Between outputs and housing: tested at 500 V AC
Surge voltage test to IEC 255-4	Between outputs and L-: $V_p = 1$ kV; 1.2/50 $\mu$ s

Front connector assignments

470-4UB

470-4UA  
470-4UC

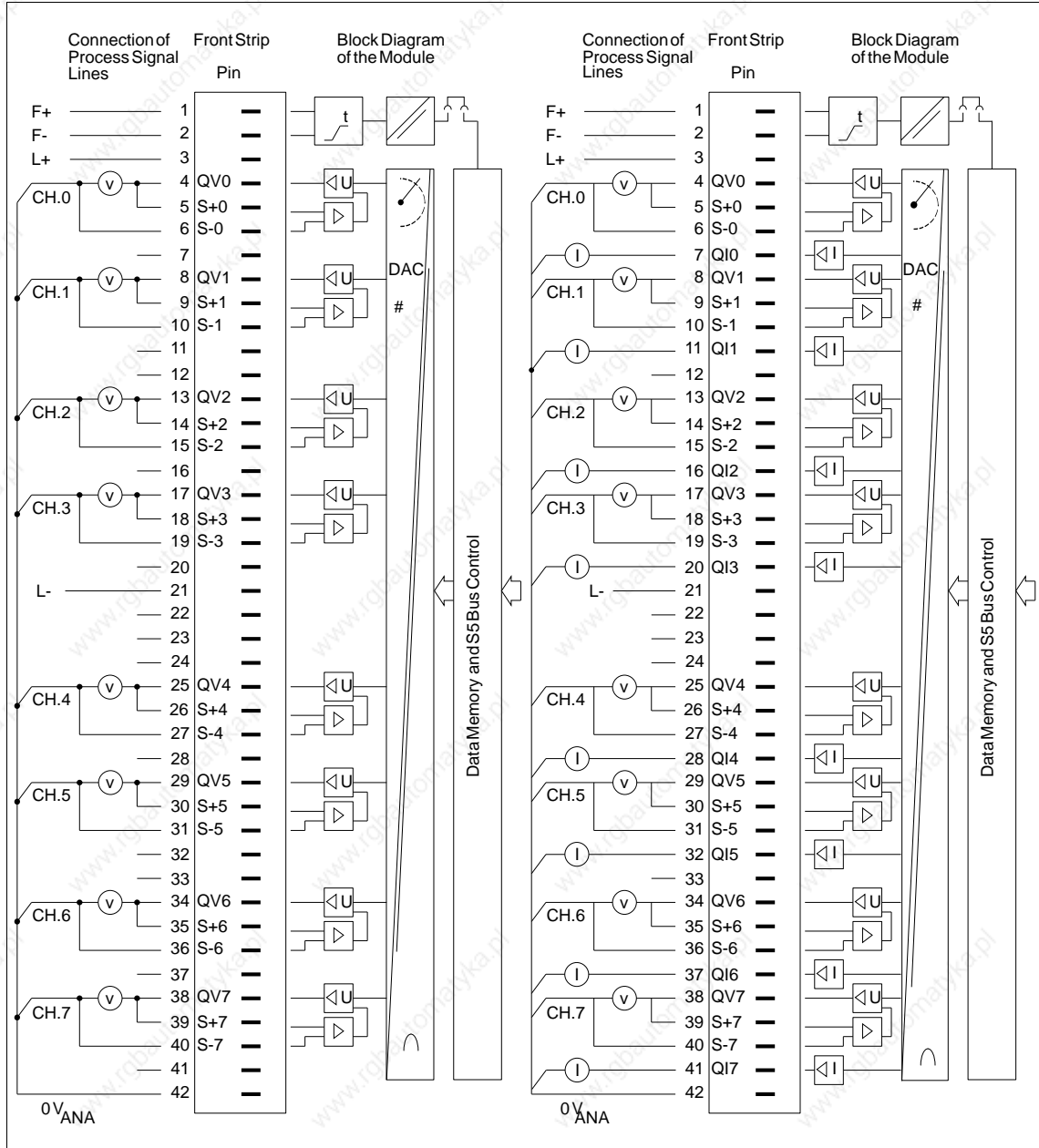

Figure 9-42 Front Connector Assignments

# Connector Assignments

# 10

Given in this chapter are

- the connector assignments of the
  - backplane for the central controllers and expansion units
  - power supplies
  - backplane connectors and front connectors of the CPUs, coordinators and IMs.

## Connector Assignments

## Connector assignments of the backplane of the S5-135U/155U CC

Slot 3, COR, I/O					Slot 11, 27, 43, 59 CPU, CP, I/O, IP				
Backplane conn. 1	Pin No.	Pin Row			Pin No.	Pin Row			
		z	b	d		z	b	d	
	2	P5 V	M5 V		2	P5 V	M5 V		
	4	PL	PESP	UBAT	4	PL	PESP	UBAT	
	6	<u>RESET</u>	ADB 0	ADB 12	6	<u>RESET</u>	ADB 0	ADB 12	
	8	<u>MEMR</u>	ADB 1	ADB 13	8	<u>MEMR</u>	ADB 1	ADB 13	
	10	<u>MEMW</u>	ADB 2	ADB 14	10	<u>MEMW</u>	ADB 2	ADB 14	
	12	<u>RDY</u>	ADB 3	ADB 15	12	<u>RDY</u>	ADB 3	ADB 15	
	14	DB 0	ADB 4	PL	14	DB 0	ADB 4	IRx <sup>1)</sup>	
	16	DB 1	ADB 5	PL	16	DB 1	ADB 5		
	18	DB 2	ADB 6	PL	18	DB 2	ADB 6		
	20	DB 3	ADB 7	PL	20	DB 3	ADB 7		
	22	DB 4	ADB 8	PL	22	DB 4	ADB 8	<u>IRE</u>	
	24	DB 5	ADB 9	PL	24	DB 5	ADB 9	<u>IRF</u>	
	26	DB 6	ADB 10	<u>PL</u>	26	DB 6	ADB 10	<u>IRG</u>	
	28	DB 7	ADB 11	<u>DSI</u>	28	DB 7	ADB 11	<u>DSI</u>	
	30		BASP	<u>PL</u>	30		BASP	<u>PL</u>	
	32	PL	M5 V	BASPA	32	PL	M5 V	BASPA	
Backplane conn. 2	2	P5 V	M5 V	PL	2	P5 V	M5 V		
	4	DB 12	DB 8	PL	4	DB 12	DB 8		
	6	DB 13	DB 9	PL	6	DB 13	DB 9	M5 V	
	8	DB 14	DB 10	PL	8	DB 14	DB 10		
	10	DB 15	DB 11	PL	10	DB 15	DB 11		
	12		PL	PL	12	<u>M5 V</u>			
	14	<u>NAU</u>	PL	PL	14	<u>NAU</u>	PL		
	16	<u>BAU</u>	PL	PL	16	<u>BAU</u>	PL		
	18	<u>RESETA</u>	PL	PL	18		M5 V		
	20		PL	PL	20		PL		
	22	<u>PEU</u>	PL	PL	22	<u>PEU</u>	PL	PL	
	24	GEP	PL	PL	24	GEP	M5 V		
	26		PL	PL	26		PL	PL	
	28	PL	PL	PL	28	PL	PL	PL	
30	M24 V <sup>2)</sup>	M24 V <sup>2)</sup>	M24 V <sup>2)</sup>	30	M24 V <sup>2)</sup>	M24 V <sup>2)</sup>	M24 V <sup>2)</sup>		
32	P24 V	M5 V	P15 V	32	P24 V	M5 V	P15 V		

## Abbreviations:

- IM-V - IM slot with additional power supply output  
 IRQ - Interrupt source (module which generates the interrupt)  
 PL - Private line

- 1) See pin designations for the interrupt signals  
 2) M24 V also serves as the return line for P15 V.



## Connector Assignments

Slots 19, 35, 51, 67, 75, 83, 91, 99 CP, IP, I/O, IRQ					Slots 107, 115, 123, 131 CP, IP, I/O, IM307 (IRQ)				
Backplane conn. 1	Pin No.	Pin Row			Pin No.	Pin Row			
		z	b	d		z	b	d	
Backplane conn. 1	2	P5 V	M5 V		2	P5 V	M5 V		
	4	PL	PESP	UBAT	4	PL	PESP	UBAT	
	6	<u>RESET</u>	ADB 0	ADB 12	6	<u>RESET</u>	ADB 0	ADB 12	
	8	<u>MEMR</u>	ADB 1	ADB 13	8	<u>MEMR</u>	ADB 1	ADB 13	
	10	<u>MEMW</u>	ADB 2	ADB 14	10	<u>MEMW</u>	ADB 2	ADB 14	
	12	<u>RDY</u>	ADB 3	<u>ADB 15</u>	12	<u>RDY</u>	ADB 3	<u>ADB 15</u>	
	14	DB 0	ADB 4	<u>IRA</u>	14	DB 0	ADB 4	<u>IRA</u>	
	16	DB 1	ADB 5	<u>IRB</u>	16	DB 1	ADB 5	<u>IRB</u>	
	18	DB 2	ADB 6	<u>IRC</u>	18	DB 2	ADB 6	<u>IRC</u>	
	20	DB 3	ADB 7	<u>IRD</u>	20	DB 3	ADB 7	<u>IRD</u>	
	22	DB 4	ADB 8	<u>IRE</u>	22	DB 4	ADB 8	<u>IRE</u>	
	24	DB 5	ADB 9	<u>IRF</u>	24	DB 5	ADB 9	<u>IRF</u>	
	26	DB 6	ADB 10	<u>IRG</u>	26	DB 6	ADB 10	<u>IRG</u>	
	28	DB 7	ADB 11	<u>DSI</u>	28	DB 7	ADB 11	<u>DSI</u>	
	30		BASP		30		BASP		
	32	PL	M5 V	<u>BASPA</u>	32	PL	M5 V	<u>BASPA</u>	
Backplane conn. 2	2	P5 V	M5 V		2	P5 V	M5 V		
	4	DB 12	DB 8		4	DB 12	DB 8		
	6	DB 13	DB 9		6	DB 13	DB 9		
	8	DB 14	DB 10		8	DB 14	DB 10		
	10	DB 15	DB 11		10	DB 15	DB 11		
	12				12				
	14	<u>NAU</u>	PL		14	<u>NAU</u>	PL		
	16	<u>BAU</u>	PL		16	<u>BAU</u>	PL		
	18				18	<u>RESETA</u>	PEU		
	20		PL	PL *	20		PL		
	22		PL		22		PL		
	24	GEP			24	GEP			
	26		PL *	PL	26			PL	
	28	PL	PL	PL	28	PL	PL	PL	
	30	M24 V <sup>1)</sup>	M24 V <sup>1)</sup>	M24 V <sup>1)</sup>	30	M24 V <sup>1)</sup>	M24 V <sup>1)</sup>	M24 V <sup>1)</sup>	
	32	P24 V	M5 V	P15 V	32	P24 V	M5 V	P15 V	

PL \* = Only at slots 75, 83, 91 and 99

1) M24 V also serves as the return line for P15 V.

Slot 139, 147 I/O, IM, IP without page addressing					Slot 155, 163 I/O, IM				
Backplane conn. 1	Pin No.	Pin Row			Pin No.	Pin Row			
		z	b	d		z	b	d	
	2	P5 V	M5 V		2	P5 V	M5 V		
	4	PL	PESP		4	PL	PESP	P5 V	
	6	<u>RESET</u>	ADB 0	ADB 12	6	<u>RESET</u>	ADB 0	ADB 12	
	8	<u>MEMR</u>	ADB 1	ADB 13	8	<u>MEMR</u>	ADB 1	ADB 13	
	10	<u>MEMW</u>	ADB 2	ADB 14	10	<u>MEMW</u>	ADB 2	ADB 14	
	12	<u>RDY</u>	ADB 3	ADB 15	12	<u>RDY</u>	ADB 3	ADB 15	
	14	DB 0	ADB 4		14	DB 0	ADB 4	P5 V	
	16	DB 1	ADB 5		16	DB 1	ADB 5	P5 V	
	18	DB 2	ADB 6	M5 V	18	DB 2	ADB 6	M5 V	
	20	DB 3	ADB 7	M5 V	20	DB 3	ADB 7	M5 V	
	22	DB 4	ADB 8	M5 V	22	DB 4	ADB 8	M5 V	
	24	DB 5	ADB 9	M5 V	24	DB 5	ADB 9	M5 V	
	26	DB 6	ADB 10	M5 V	26	DB 6	ADB 10	M5 V	
	28	DB 7	ADB 11	M5 V	28	DB 7	ADB 11	M5 V	
	30		BASP	<u>M5 V</u>	30		BASP	<u>M5 V</u>	
	32		M5 V	<u>BASPA</u>	32		M5 V	<u>BASPA</u>	
Backplane conn. 2	2	P5 V	M5 V		2	P5 V	M5 V		
	4	DB 12	DB 8		4	DB 12	DB 8		
	6	DB 13	DB 9		6	DB 13	DB 9		
	8	DB 14	DB 10		8	DB 14	DB 10		
	10	DB 15	DB 11		10	DB 15	DB 11		
	12				12	P5 V	P5 V		
	14				14	P5 V	P5 V		
	16				16	<u>P5 V</u>	<u>P5 V</u>		
	18	<u>RESETA</u>	<u>PEU</u>		18	<u>RESETA</u>	<u>PEU</u>		
	20				20				
	22	M5 V	M5 V		22	M5 V	M5 V		
	24	M5 V	M5 V		24	M5 V	M5 V		
	26	M5 V	M5 V		26	M5 V	M5 V		
	28	M5 V	M5 V		28	M5 V	M5 V		
30	M5 V	M5 V		30	M5 V	M5 V			
32	M5 V	M5 V		32	M5 V	M5 V			

Pin designations of the interrupt signals on the backplane

Module	Interrupt Sink				Interrupt Source
	CPU 1	CPU 2	CPU 3	CPU 4	
Slot No.	11	27	43	59	19, 35, 51, 67-131
Signal					
<u>IRA</u>	1d 14				1d 14
<u>IRB</u>		1d 14			1d 16
<u>IRC</u>			1d 14		1d 18
<u>IRD</u>				1d 14	1d 20
<u>IRE</u> (CPU 948 only)	1d 22	1d 22	1d 22	1d 22	1d 22
<u>IRF</u> (CPU 948 only)	1d 24	1d 24	1d 24	1d 24	1d 24
<u>IRG</u> (CPU 948 only)	1d 26	1d 26	1d 26	1d 26	1d 26

**Connector assignments of the backplane for the EU 183U, 184U and 187U**

I/O modules				IM 312-5			
		EU	Slot			EU	Slot
		183U	11 to 155			184U	163
		184U	3 to 155			187U	
		187U	3 to 147				
Backplane conn. 1	Pin No.	Pin Row		Pin No.	Pin Row		
		z	b		z	b	d
	2	+5V	0V	2	+5V	0V	Shield
	4	-	PESP	4	-	PESP	+5V
	6	CPKL	ADB0	6	CPKL	ADB0	+5V
	8	MEMR	ADB1	8	MEMR	ADB1	+5V
	10	MEMW	ADB2	10	MEMW	ADB2	+5V
	12	RDY	ADB3	12	RDY	ADB3	+5V
	14	DB0	ADB4	14	DB0	ADB4	+5V
	16	DB1	ADB5	16	DB1	ADB5	+5V
	18	DB2	ADB6	18	DB2	ADB6	0V
	20	DB3	ADB7	20	DB3	ADB7	0V
	22	DB4	0V	22	DB4	0V	0V
	24	DB5	0V	24	DB5	0V	0V
	26	DB6	0V	26	DB6	0V	0V
	28	DB7	0V	28	DB7	0V	0V
	30	-	BASP	30	-	BASP	0V
	32	-	0V	32	0V	0V	0V

IM 300-3 and -5 / 312-3					IM 310, IM 314, IM 317, IM 318					
		EU	Slot					Slot		
		183U	163					3		
Backplane conn. 1	Pin No.	Pin Row			Pin No.	Pin Row				
		z	b	d		z	b	d		
	2	+5V	0V	Shield	2	+5V	0V	Shield		
	4	-	PESP	+5V	4	Takt	PESP	+5V		
	6	CPKL	ADB0	-	6	CPKL	ADB0	-		
	8	MEMR	ADB1	-	8	MEMR	ADB1	-		
	10	MEMW	ADB2	-	10	MEMW	ADB2	-		
	12	RDY	ADB3	-	12	RDY	ADB3	-		
	14	DB0	ADB4	+5V	14	DB0	ADB4	+5V		
	16	DB1	ADB5	+5V	16	DB1	ADB5	+5V		
	18	DB2	ADB6	0V	18	DB2	ADB6	0V		
	20	DB3	ADB7	0V	20	DB3	ADB7	0V		
	22	DB4	0V	0V	22	DB4	0V	0V		
	24	DB5	0V	0V	24	DB5	0V	0V		
	26	DB6	0V	0V	26	DB6	0V	0V		
	28	DB7	0V	0V	28	DB7	0V	0V		
	30	EANK	BASP	0V	30	-	BASP	0V		
	32	-	0V	BASPA	32	-	0V	BASPA		
Backplane conn. 2	Pin No.	Pin Row			Pin No.	Pin Row				
		z	b	d		z	b	d		
	2	+5V	0V	-	2	+5V	0V	-		
	4	-	-	0V	4	-	-	0V		
	6	-	-	-	6	-	-	-		
	8	-	-	-	8	-	-	-		
	10	-	-	-	10	-	-	-		
	12	+5V	+5V	+5V	12	+5V	+5V	+5V		
	14	+5V	+5V	+5V	14	+5V	+5V	+5V		
	16	+5V	+5V	+5V	16	+5V	+5V	+5V		
	18	CPKLA	NAU	-	18	CPKLA	NAU	-		
	20	-	-	-	20	-	-	-		
	22	0V	0V	-	22	0V	0V	-		
	24	0V	0V	-	24	0V	0V	-		
	26	0V	0V	-	26	0V	0V	-		
	28	0V	0V	-	28	0V	0V	-		
	30	0V	0V	-	30	0V	0V	-		
	32	0V	0V	-	32	0V	0V	-		

Connector assignments of the backplane for the EU 185U

	IM 310 and IM 314 I/O Module Slot 3				923C Coordinator I/O Module Slot 11			
	Pin No.	Pin Row			Pin No.	Pin Row		
		z	b	d		z	b	d
Backplane conn. 1	2	+ 5 V	0 V		2	+ 5 V	0 V	
	4		PESP		4		PESP	UBAT
	6	<u>RESET</u>	ADB0	ADB12	6	<u>RESET</u>	ADB0	ADB12
	8	<u>MEMR</u>	ADB1	ADB13	8	<u>MEMR</u>	ADB1	ADB13
	10	<u>MEMW</u>	ADB2	ADB14	10	<u>MEMW</u>	ADB2	ADB14
	12	<u>RDY</u>	ADB3	ADB15	12	<u>RDY</u>	ADB3	ADB15
	14	<u>DB0</u>	ADB4		14	<u>DB0</u>	ADB4	
	16	<u>DB1</u>	ADB5		16	<u>DB1</u>	ADB5	
	18	<u>DB2</u>	ADB6	0 V	18	<u>DB2</u>	ADB6	
	20	<u>DB3</u>	ADB7	0 V	20	<u>DB3</u>	ADB7	
	22	<u>DB4</u>	ADB8	0 V	22	<u>DB4</u>	ADB8	
	24	<u>DB5</u>	ADB9	0 V	24	<u>DB5</u>	ADB9	
	26	<u>DB6</u>	ADB10	0 V	26	<u>DB6</u>	ADB10	
	28	<u>DB7</u>	ADB11	0 V	28	<u>DB7</u>	ADB11	<u>DSI</u>
	30	<u>DSI</u>	BASP	0 V	30		BASP	
32		0 V	<u>BASPA</u>	32		0 V	<u>BASPA</u>	
Backplane conn. 2	2	+ 5 V	0 V		2	+ 5 V	0 V	
	4	<u>DB12</u>	DB8	0 V	4	<u>DB12</u>	DB8	
	6	<u>DB13</u>	DB9	<u>RESET</u>	6	<u>DB13</u>	DB9	RxDs8
	8	<u>DB14</u>	DB10		8	<u>DB14</u>	DB10	TxDs8
	10	<u>DB15</u>	DB11		10	<u>DB15</u>	DB11	RxDs7
	12		+ 5V		12		RxDs6	TxDs7
	14		+ 5V		14	<u>NAU</u>	TxDs6	RxDs5
	16		+ 5V		16	<u>BAU</u>	RxDs4	TxDs5
	18	<u>RESETA</u>	<u>NAU</u>		18	<u>RESETA</u>	TxDs4	RxDs3
	20				20			TxDs3
	22	0 V	0 V		22	<u>PEU</u>		•RxDs1
	24	0 V	0 V		24	<u>GEP</u>	RxDs2	TxDs1
	26	0 V	0 V		26		TxDs2	
	28	0 V	0 V		28			SPRxD
	30	0 V	0 V		30	M2	M2	M2
32	0 V	0 V		32	+ 24V	0 V	+ 15 V	

## Connector Assignments

	Communications Processor Intelligent I/Os I/O Module Slots 19 to 75				Communications Processor Intelligent I/Os I/O Module Slots 83 to 139			
	Pin No.	Pin Row			Pin No.	Pin Row		
		z	b	d		z	b	d
Backplane conn. 1	2	+5 V	0 V		2	+5 V	0 V	
	4		PESP	UBAT	4		PESP	UBAT
	6	<u>RESET</u>	ADB0	ADB12	6	<u>RESET</u>	ADB0	ADB12
	8	<u>MEMR</u>	ADB1	ADB13	8	<u>MEMR</u>	ADB1	ADB13
	10	<u>MEMW</u>	ADB2	ADB14	10	<u>MEMW</u>	ADB2	ADB14
	12	<u>RDY</u>	ADB3	ADB15	12	<u>RDY</u>	ADB3	ADB15
	14	DB0	ADB4		14	DB0	ADB4	
	16	DB1	ADB5		16	DB1	ADB5	
	18	DB2	ADB6		18	DB2	ADB6	
	20	DB3	ADB7		20	DB3	ADB7	
	22	DB4	ADB8		22	DB4	ADB8	
	24	DB5	ADB9		24	DB5	ADB9	
	26	DB6	ADB10		26	DB6	ADB10	
	28	DB7	ADB11	<u>DSI</u>	28	DB7	ADB11	<u>DSI</u>
30		BASP		30		BASP		
32		0 V	<u>BASPA</u>	32		0 V	<u>BASPA</u>	
Backplane conn. 2	2	+5 V	0 V		2	+5 V	0 V	
	4	DB12	DB8		4	DB12	DB8	
	6	DB13	DB9		6	DB13	DB9	
	8	DB14	DB10		8	DB14	DB10	
	10	DB15	DB11		10	DB15	DB11	
	12				12			
	14	<u>NAU</u>			14	<u>NAU</u>		
	16	<u>BAU</u>			16	<u>BAU</u>		
	18				18			
	20				20			
	22	<u>PEU</u>		TxDsn	22	<u>PEU</u>		
	24	<u>GEP</u>			24	<u>GEP</u>		
	26		RxDsn		26			
	28			SPRxD	28			
30	M2	M2	M2	30	M2	M2	M2	
32	+24 V	0 V	+15 V	32	+24 V	0 V	+15 V	

	IM 314 R I/O Module Slot 147, 155				IM 300 I/O Module Slot 163			
	Pin No.	Pin Row			Pin No.	Pin Row		
		z	b	d		z	b	d
Backplane conn. 1	2	+ 5 V	0 V	Shield	2	+ 5 V	0 V	
	4		PESP		4		PESP	+ 5 V
	6	<u>RESET</u>	ADB0	ADB12	6	<u>RESET</u>	ADB0	ADB12
	8	<u>MEMR</u>	ADB1	ADB13	8	<u>MEMR</u>	ADB1	ADB13
	10	<u>MEMW</u>	ADB2	ADB14	10	<u>MEMW</u>	ADB2	ADB14
	12	RDY	ADB3	ADB15	12	RDY	ADB3	ADB15
	14	DB0	ADB4		14	DB0	ADB4	+ 5 V
	16	DB1	ADB5		16	DB1	ADB5	+ 5 V
	18	DB2	ADB6		18	DB2	ADB6	0 V
	20	DB3	ADB7		20	DB3	ADB7	0 V
	22	DB4	ADB8		22	DB4	ADB8	0 V
	24	DB5	ADB9		24	DB5	ADB9	0 V
	26	DB6	ADB10		26	DB6	ADB10	0 V
	28	DB7	ADB11		28	DB7	ADB11	0 V
30		BASP	0 V	30		BASP	0 V	
32	0 V	0 V	<u>BASPA</u>	32	0 V	0 V	<u>BASPA</u>	
Backplane conn. 2	2	+ 5 V	0 V		2	+ 5 V	0 V	
	4	NA0	SA0	0 V	4			
	6	NA1	SA1	RESET	6			
	8	NA2	SA2		8			
	10	NA3	SA3		10			
	12				12	+ 5 V	+ 5 V	
	14				14	+ 5 V	+ 5 V	
	16				16	+ 5 V	+ 5 V	
	18	<u>RESETA</u>	<u>NAU</u>		18	<u>RESETA</u>	<u>NAU</u>	
	20				20			
	22	0 V	0 V		22	0 V	0 V	
	24	0 V	0 V		24	0 V	0 V	
	26	0 V	0 V		26	0 V	0 V	
	28	0 V	0 V		28	0 V	0 V	
30	0 V	0 V		30	0 V	0 V		
32	0 V	0 V		32	0 V	0 V		







Assignments of the backplane connector CPU 948

	Pin No.	Pin Row		
		z	b	d
Backplane conn. 1	2	+ 5 V	M 5 V	
	4		PESP	UBAT
	6	<u>RESET</u>	ADB 0	ADB 12
	8	<u>MEMR</u>	ADB 1	ADB 13
	10	<u>MEMW</u>	ADB 2	ADB 14
	12	<u>RDY</u>	ADB 3	<u>ADB 15</u>
	14	DB0	ADB 4	<u>IR</u>
	16	DB1	ADB 5	
	18	DB2	ADB 6	<u>IRE</u>
	20	DB3	ADB 7	<u>IRF</u>
	22	DB4	ADB 8	<u>IRG</u>
	24	DB5	ADB 9	<u>DSI</u>
	26	DB6	ADB 10	<u>BUSEN</u>
	28	DB7	ADB 11	<u>BASPA</u>
30		BASP		
32	<u>HALT</u>	M 5 V		
Backplane conn. 2	2	+5 V	M 5 V	
	4	DB 12	DB 8	
	6	DB 13	DB 9	M 5 V
	8	DB 14	DB 10	
	10	DB 15	DB 11	
	12	<u>M 5 V</u>		
	14	<u>NAU</u>	PGBUSX	
	16	<u>BAU</u>	PGBUSY	
	18	+5V	<u>M 5 V</u>	
	20		<u>STEU</u>	
	22	<u>PEU</u>	<u>STOPPA</u>	T x D
	24	GEP	<u>M 5 V</u>	
	26		<u>R x D</u>	<u>TEST</u>
	28		<u>PERO</u>	
30	M 24 V	M 24 V	M 24V	
32	+ 24 V	M 5 V		

## Assignments of the backplane connector CPU 928B

	Pin No.	Pin Row		
		z	b	d
Backplane conn. 1	2	+ 5 V	M 5 V	
	4		PESP	UBAT
	6	<u>CPKL</u>	ADB 0	ADB 12
	8	<u>MEMR</u>	ADB 1	ADB 13
	10	<u>MEMW</u>	ADB 2	ADB 14
	12	<u>RDY</u>	ADB 3	ADB 15
	14	DB0	ADB 4	<u>IR</u>
	16	DB1	ADB 5	
	18	DB2	ADB 6	
	20	DB3	ADB 7	
	22	DB4	ADB 8	
	24	DB5	ADB 9	
	26	DB6	ADB 10	
	28	DB7	ADB 11	<u>DSI</u>
30		BASP	<u>BUSEN</u>	
32	<u>HALT</u>	M 5 V	<u>BASPA</u>	
Backplane conn. 2	2	+5 V	M 5 V	
	4	DB 12	DB 8	
	6	DB 13	DB 9	M 5 V
	8	DB 14	DB 10	
	10	DB 15	DB 11	
	12	<u>M 5 V</u>		
	14	<u>NAU</u>		
	16	<u>BAU</u>		
	18	+5V	<u>M 5 V</u>	
	20		<u>STEU</u>	
	22	<u>PEU</u>	<u>STOPPA</u>	<u>T x D</u>
	24	GEP	M 5 V	
	26		<u>R x D</u>	<u>TEST</u>
	28		<u>PERO</u>	
30	M 24 V	M 24 V		
32	+ 24 V	M 5 V		

Assignments of the backplane connector CPU 928

	Pin No.	Pin Row		
		z	b	d
Backplane conn. 1	2	+ 5 V	M 5 V	
	4		PESP	UBAT
	6	<u>CPKL</u>	ADB 0	ADB 12
	8	<u>MEMR</u>	ADB 1	ADB 13
	10	<u>MEMW</u>	ADB 2	ADB 14
	12	<u>RDY</u>	ADB 3	<u>ADB 15</u>
	14	DB0	ADB 4	<u>IR</u>
	16	DB1	ADB 5	
	18	DB2	ADB 6	
	20	DB3	ADB 7	
	22	DB4	ADB 8	
	24	DB5	ADB 9	
	26	DB6	ADB 10	
	28	DB7	ADB 11	<u>DSI</u>
30		BASP	<u>BUSEN</u>	
32	<u>HALT</u>	M 5 V	<u>BASPA</u>	
Backplane conn. 2	2	+5 V	M 5 V	
	4	DB 12	DB 8	
	6	DB 13	DB 9	M 5 V
	8	DB 14	DB 10	
	10	DB 15	DB 11	
	12	<u>M 5 V</u>		
	14	<u>NAU</u>		
	16	<u>BAU</u>		
	18	+5V	<u>M 5 V</u>	
	20		<u>STEU</u>	
	22	<u>PEU</u>	<u>STOPPA</u>	<u>T x D</u>
	24	GEP	M 5 V	
	26		<u>R x D</u>	<u>TEST</u>
	28		<u>PERO</u>	
30	M 24 V	M 24 V		
32	+ 24 V	M 5 V		

## Assignments of the backplane connector CPU 922

	Pin No.	Pin Row		
		z	b	d
Backplane conn. 1	2	+ 5 V	M 5 V	
	4		PESP	UBAT
	6	<u>CPKL</u>	ADB 0	ADB 12
	8	<u>MEMR</u>	ADB 1	ADB 13
	10	<u>MEMW</u>	ADB 2	ADB 14
	12	<u>RDY</u>	ADB 3	ADB 15
	14	DB0	ADB 4	<u>IR</u>
	16	DB1	ADB 5	
	18	DB2	ADB 6	
	20	DB3	ADB 7	
	22	DB4	ADB 8	
	24	DB5	ADB 9	
	26	DB6	ADB 10	
	28	<u>DB7</u>	ADB 11	<u>DSI</u>
30	<u>QUITT</u>	BASP	<u>BUSEN</u>	
32	<u>HALT</u>	M 5 V	<u>BASPA</u>	
Backplane conn. 2	2	+5 V	M 5 V	
	4			M 5 V
	6			
	8			
	10			
	12	<u>M 5 V</u>		
	14	<u>NAU</u>		
	16	<u>BAU</u>		
	18		<u>M 5 V</u>	
	20		<u>STEU</u>	
	22	<u>PEU</u>	<u>STOPPA</u>	<u>T x D</u>
	24	GEP	M 5 V	
	26		<u>R x D</u>	<u>TEST</u>
	28		<u>PERO</u>	
30	M 24 V	M 24 V		
32	+ 24 V	M 5 V		

**Assignments of the CPU front connector (PG interface)**

Pin No.	Designation
1	Housing/0 V/0 V <sub>ext</sub>
2	R x D
3	VPG + 5 V DC
4	+ 24 V from bus
5	0 V/0 V <sub>int</sub>
6	<u>TxD</u>
7	<u>TxD</u>
8	Housing/0 V/0 V <sub>ext</sub>
9	R x D
10	24 V ground
11	20 mA/transmitter
12	0 V/0 V <sub>int</sub>
13	20 mA/receiver
14	VPG + 5 V DC
15	0 V/0 V <sub>int</sub>

## Assignments of the backplane connector: 923A coordinator

	Pin No.	Pin Row		
		z	b	d
Backplane conn. 1	2	+ 5 V	M 5 V	UBAT  BUSEN 1 BUSEN 2 BUSEN 3 BUSEN 4  <u>DSI</u>
	4			
	6	<u>RESET</u>	ADB 0	
	8	<u>MEMR</u>	ADB 1	
	10	<u>MEMW</u>	ADB 2	
	12	<u>RDY</u>	ADB 3	
	14	DB 0	ADB 4	
	16	DB 1	ADB 5	
	18	DB 2	ADB 6	
	20	DB 3	ADB 7	
	22	DB 4	ADB 8	
	24	DB 5	ADB 9	
	26	DB 6	ADB 10	
	28	DB 7	ADB 11	
	30			
32	<u>HALT</u>	M 5 V		
Backplane conn. 2	2	+ 5 V	M 5 V	<u>TEST</u>
	4			
	6			
	8			
	10			
	12			
	14	<u>NAU</u>		
	16			
	18			
	20		<u>STEU</u>	
	22		STOPPA	
	24			
	26			
	28		<u>PERO</u>	
	30			
32		M 5 V		

Assignments of the backplane connector: 923C coordinator

Backplane connector 1

	Pin No.	Pin Row		
		z	b	d
Backplane conn. 1	2	+ 5 V	M 5 V	
	4			UBAT
	6	<u>RESET</u>	ADB 0	ADB 12
	8	<u>MEMR</u>	ADB 1	ADB 13
	10	<u>MEMW</u>	ADB 2	ADB 14
	12	<u>RDY</u>	ADB 3	ADB 15
	14	DB 0	ADB 4	BUSEN 1
	16	DB 1	ADB 5	BUSEN 2
	18	DB 2	ADB 6	BUSEN 3
	20	DB 3	ADB 7	BUSEN 4
	22	DB 4	ADB 8	
	24	DB 5	ADB 9	
	26	DB 6	ADB 10	
	28	DB 7	ADB 11	<u>DSI</u>
	30			
32	<u>HALT</u>	M 5 V		
Backplane conn. 2	2	+ 5 V	M 5 V	
	4			
	6			<u>RxD 8</u>
	8			<u>TxD 8</u>
	10			<u>RxD 7</u>
	12		<u>RxD 6</u>	<u>TxD 7</u>
	14	<u>NAU</u>	<u>TxD 6</u>	<u>RxD 5</u>
	16		<u>RxD 4</u>	<u>TxD 5</u>
	18		<u>TxD 4</u>	<u>RxD 3</u>
	20		<u>STEU</u>	<u>TxD 3</u>
	22		<u>STOPPA</u>	<u>RxD 1</u>
	24			<u>TxD 1</u>
	26			<u>TEST</u>
	28		<u>PERO</u>	
	30	M 24 V		
32	M 5 V	M 5 V		

**Assignments of the front connector for the coordinators**

Pin No.	Designation
1	Housing/0 V/0 V <sub>ext</sub>
2	Receiver TTY(-)
3	Private line
4	+24 V
5	Private line
6	Transmitter TTY (+)
7	Transmitter TTY (-)
8	Housing/0 V/0 V <sub>ext</sub>
9	Receiver TTY (+)
10	24 V ground (20 mA (-) current sources)
11	20 mA (+) current source
12	Private line
13	20 mA (+) current source
14	Private line
15	Private line



Assignments of the backplane connectors of the IMs

		IM 300-3			IM 300-5			IM 300-5L			IM 301-3		
		Pin Row			Pin Row			Pin Row			Pin Row		
	Pin	z	b	d	z	b	d	z	b	d	z	b	d
B	2	+5V	0V	Shield	+5V	0V	Shield	+5V	M	-	+5V	0V	Shield
a	4	-	PESP	-	-	PESP	+5V	-	PESP	-	-	PESP	-
c	6	CPKL	ADB0	-	CPKL	ADB0	-	RESET	ADB1	-	CPKL	ADB0	-
k	8	MEMR	ADB1	-	MEMR	ADB1	-	MRD	ADB2	-	MEMR	ADB1	-
p	10	MEMW	ADB2	-	MEMW	ADB2	-	MWR	ADB3	-	MEMW	ADB2	-
l	12	RDY	ADB3	-	RDY	ADB3	-	RDY	ADB4	-	RDY	ADB3	-
a	14	DB0	ADB4	-	DB0	ADB4	+5V	DB0	ADB5	-	DB0	ADB4	-
n	16	DB1	ADB5	-	DB1	ADB5	+5V	DB1	ADB6	-	DB1	ADB5	-
e	18	DB2	ADB6	0V	DB2	ADB6	0V	DB2	ADB7	-	DB2	ADB6	0V
	20	DB3	ADB7	0V	DB3	ADB7	0V	DB3	ADB8	-	DB3	ADB7	0V
c	22	DB4	0V	0V	DB4	ADB 8	0V	DB4	ADB9	-	DB4	ADB 8	0V
o	24	DB5	0V	0V	DB5	ADB 9	0V	DB5	ADB10	-	DB5	ADB 9	0V
n	26	DB6	0V	0V	DB6	ADB 10	0V	DB6	ADB11	-	DB6	ADB 10	0V
n.	28	DB7	0V	0V	DB7	ADB 11	0V	DB7	BASP	-	DB7	ADB 11	0V
	30	-	BASP	0V	-	BASP	0V	-	M	-	-	BASP	0V
l	32	-	0V	-	0V	0V	-	-	-	-	-	0V	-
B	2	+5V	-	-	+5V	-	-	+5V	M	-	+5V	-	-
a	4	-	-	-	-	-	-	-	-	-	-	-	-
c	6	-	-	-	-	-	-	-	-	-	-	-	-
k	8	-	-	-	-	-	-	-	-	-	-	-	-
p	10	-	-	-	-	-	-	-	-	-	-	-	-
l	12	-	-	-	+5V	+5V	-	-	-	-	+5V	+5V	-
a	14	-	-	-	+5V	+5V	-	-	-	-	+5V	+5V	-
n	16	-	-	-	+5V	+5V	-	-	-	-	+5V	+5V	-
e	18	-	NAU	-	-	-	-	-	PEU	-	-	NAU	-
	20	-	-	-	-	-	-	-	-	-	-	-	-
c	22	0V	0V	-	0V	0V	-	-	-	-	0V	0V	-
o	24	0V	0V	-	0V	0V	-	-	-	-	0V	0V	-
n	26	0V	0V	-	0V	0V	-	-	-	-	0V	0V	-
n.	28	0V	0V	-	0V	0V	-	-	-	-	0V	0V	-
	30	0V	0V	-	0V	0V	-	-	-	-	0V	0V	-
2	32	0V	0V	-	0V	0V	-	-	M	-	0V	0V	-

		IM 301-5			IM 304		
		Pin Row			Pin Row		
	Pin	z	b	d	z	b	d
B	2	+5V	0V	Shield	+5V	M	-
a	4	-	PESP	+5V	-	-	-
c	6	CPKL	ADB0	-	CPKL	ADB0	ADB 12
k	8	MEMR	ADB1	-	MEMR	ADB1	ADB 13
p	10	MEMW	ADB2	-	MEMW	ADB2	ADB14
l	12	RDY	ADB3	-	RDY	ADB3	ADB15
a	14	DB0	ADB4	+5V	DB0	ADB4	-
n	16	DB1	ADB5	+5V	DB1	ADB5	-
e	18	DB2	ADB6	0V	DB2	ADB6	-
	20	DB3	ADB7	0V	DB3	ADB7	-
c	22	DB4	ADB 8	0V	DB4	ADB8	-
o	24	DB5	ADB 9	0V	DB5	ADB9	-
n	26	DB6	ADB 10	0V	DB6	ADB10	-
n.	28	DB7	ADB 11	0V	DB7	ADB11	-
	30	-	BASP	0V	-	BASP	-
l	32	0V	0V	-	-	M	-
B	2	+5V	-	-	+5V	M	-
a	4	-	-	-	DB12	DB8	-
c	6	-	-	-	DB13	DB9	-
k	8	-	-	-	DB14	DB10	-
p	10	-	-	-	DB15	DB11	-
l	12	+5V	+5V	-	-	-	-
a	14	+5V	+5V	-	PEU *	-	-
n	16	+5V	+5V	-	-	-	-
e	18	-	NAU	-	-	PEU *	-
	20	-	-	-	-	-	-
c	22	0V	0V	-	-	-	-
o	24	0V	0V	-	-	-	-
n	26	0V	0V	-	-	-	-
n.	28	0V	0V	-	-	-	-
	30	0V	0V	-	-	-	-
2	32	0V	0V	-	-	M	-

Connector Assignments

		IM 310-3			IM 312-3			IM 312-5			IM 314		
		Pin Row			Pin Row			Pin Row			Pin Row		
	Pin	z	b	d	z	b	d	z	b	d	z	b	d
B	2	+5V	0V	Shield	+5V	0V	-	+5V	0V	-	+5V	M	-
a	4	-	PESP	+5V	-	PESP	+5V	-	PESP	+5V	-	PESP	+5V
c	6	CPKL	ADB0	-	CPKL	ADB0	+5V	CPKL	ADB0	+5V	<u>CPKLa</u>	ADB0	ADB12
k	8	MEMRA	DB1	-	MEMR	ADB1	+5V	MEMR	ADB1	+5V	<u>MEMR</u>	ADB1	ADB13
p	10	MEMW	ADB2	-	MEMW	ADB2	+5V	MEMW	ADB2	+5V	<u>MEMW</u>	ADB2	ADB14
l	12	RDY	ADB3	-	RDY	ADB3	+5V	RDY	ADB3	+5V	RDY	ADB3	ADB15
a	14	DB0	ADB4	+5V	DB0	ADB4	+5V	DB0	ADB4	+5V	DB0	ADB4	-
n	16	DB1	ADB5	+5V	DB1	ADB5	+5V	DB1	ADB5	+5V	DB1	ADB5	-
e	18	DB2	ADB6	0V	DB2	ADB6	0V	DB2	ADB6	0V	DB2	ADB6	-
	20	DB3	ADB7	0V	DB3	ADB7	0V	DB3	ADB7	0V	DB3	ADB7	-
c	22	DB4	-	0V	DB4	-	0V	DB4	-	0V	DB4	ADB8	-
o	24	DB5	-	0V	DB5	-	0V	DB5	-	0V	DB5	ADB9	-
n	26	DB6	-	0V	DB6	-	0V	DB6	-	0V	DB6	ADB10	-
n.	28	DB7	-	0V	DB7	-	0V	DB7	-	0V	<u>DB7</u>	ADB11	-
	30	-	BASP	0V	NAU	BASP	0V	-	BASP	0V	DSI	BASP	-
l	32	-	0V	-	-	0V	BASPA	-	0V	-	-	M	-
B	2	+5V	0V	-							+5V	M	-
a	4	-	-	US							DB12	DB8	-
c	6	-	-	-							DB13	DB9	<u>CPKLe</u>
k	8	-	-	-							DB14	DB10	-
p	10	-	-	-							DB15	DB11	-
l	12	-	-	+5V							-	+5V	-
a	14	-	-	+5V							-	+5V	-
n	16	-	-	+5V							-	+5V	-
e	18	CPKLA	NAU	-							<u>CPKLA</u>	NAU	-
	20	-	-	-							-	-	-
c	22	0V	0V	-							M	M	-
o	24	0V	0V	-							M	M	-
n	26	0V	0V	-							M	M	-
n.	28	0V	0V	-							M	M	-
	30	0V	0V	-							M	M	-
2	32	0V	0V	-							M	M	-

## Assignments of the front blade connectors

Pin No.	IM 300-3	IM 300-5C		IM 300-5L	IM 301		IM 304	
	Blade Connector 3	Blade Connector 3	Blade Connector 4	Blade Conn. 3, 4	Blade Connector 3	Blade Connector 4	Blade Connector 3	Blade Connector 4
1	Shield	0 V <sub>ext</sub>	0 V <sub>ext</sub>	Shield	Shield	Shield		
2	-	+ 5V	+ 5V	+ 5 V	-	+ ADB 4	+ AD 12	+ AD 12
3	-	+ 5V	+ 5V	+ 5 V	-	- ADB 4	- AD 12	- AD 12
4	-	+ 5V	+ 5V	+ 5 V	-	+ ADB 5	+ AD 13	+ AD 13
5	+PEU	+ 5V	+ 5V	PEU1	+PEU	- ADB 5	- AD 13	- AD 13
6	- PEU	+ 5V	+ 5V	PEU2	- PEU	+ ADB 6	+ AD 14	+ AD 14
7	ADB1	ADB 1	ADB 1	ADB1	ADB1	- ADB 6	- AD 14	- AD 14
8	ADB4	ADB 4	ADB 4	ADB4	ADB4	+ ADB 7	+ AD 15	+ AD 15
9	ADB7	ADB 7	ADB 7	ADB7	ADB7	- ADB 7	- AD 15	- AD 15
10	DB1	DB 1	DB 1	DB1	DB1	+ DB 6	+ AD 6	+ AD 6
11	DB4	DB 4	DB 4	DB4	DB4	- DB 6	- AD 6	- AD 6
12	0V	0V	0V	M	0V	+ DB 7	+ AD 7	+ AD 7
13	0V	0V	0V	M	0V	- DB 7	- AD 7	- AD 7
14	0V	0V	0V	M	0V	+ PEU	+ PEU	+ PEU **
15	0V	0V	0V	M	0V	- PEU	- PEU	- PEU **
16	0V	0V	0V	M	0V	Rg 0	-	0V
17	Shield	0V <sub>ext</sub>	0V <sub>ext</sub>	Shield	Shield	Shield		-0V
18	-	+ 5V	+ 5V	+ 5 V	-	+ ADB 0	+ AD 8	+ AD 8
19	-	+ 5V	+ 5V	+ 5 V	-	- ADB 0	- AD 8	- AD 8
20	-	+ 5V	+ 5V	+ 5 V	-	+ ADB 1	+ AD 9	+ AD 9
21	+ ZGU	+ 5V	+ 5V	+ 5 V	- ZGU	- ADB 1	- AD 9	- AD 9
22	- ZGU	+ 5V	+ 5V	+ 5 V	+ ZGU	+ ADB 2	+ AD 10	+ AD 10
23	ADB0	ADB 0	ADB 0	ADB0	ADB0	- ADB 2	- AD 10	- AD 10
24	ADB3	ADB 3	ADB 3	ADB3	ADB3	+ ADB 3	+ AD 11	+ AD 11
25	ADB6	ADB 6	ADB 6	ADB6	ADB6	- ADB 3	- AD 11	- AD 11
26	0V	0V	0V	M	0V	+ DB 3	+ AD 3	+ AD 3
27	DB3	DB 3	DB 3	DB3	DB3	- DB 3	- AD 3	- AD 3
28	DB6	DB 6	DB 6	DB6	DB6	+ DB 4	+ AD 4	+ AD 4
29	0V	0V	0V	M	0V	- DB 4	- AD 4	- AD 4
30	0V	0V	0V	M	0V	+ DB 5	+ AD 5	+ AD 5
31	0V	0V	0V	M	0V	- DB 5	- AD 5	- AD 5
32	0V	0V	0V	M	0V	+ ZGU	+ ZGU	(ZGU/ PAR) *
33	0V	0V	0V	M	0V	- ZGU	- ZGU	PAR) *
34	-	+5V	+5V	+ 5 V	-	+ MEMR	+ MEMR	+ MEMR
35	-	FAKT	FAKT		-	- MEMR	- MEMR	- MEMR
36	CPKL	CPKL	CPKL	<u>RESET</u>	CPKL	+ MEMW	+ MEMW	+ MEMW
37	MEMR	MEMR	MEMR	<u>MRD</u>	MEMR	- MEMW	- MEMW	- MEMW
38	MEMW	MEMW	MEMW	<u>MWR</u>	MEMW	+ PESP	+ ALE	+ ALE
39	PESP	PESP	PESP	<u>PESP</u>	PESP	- PESP	- ALE	- ALE
40	ADB2	ADB 2	ADB 2	ADB2	ADB2	+ BASP	+ BASP	(BASP/ PAF) *
41	ADB5	ADB 5	ADB 5	ADB5	ADB5	- BASP	- BASP	PAF) *
42	DB0	DB 0	DB 0	DB0	DB0	+ DB 0	+ AD0	+ AD0
43	DB2	DB 2	DB 2	DB2	DB2	- DB 0	- AD 0	- AD 0
44	DB5	DB 5	DB 5	DB5	DB5	+ DB 1	+ AD 1	+ AD 1
45	DB7	DB 7	DB 7	<u>DB7</u>	DB7	- DB 1	- AD 1	- AD 1
46	RDY	RDY	RDY	<u>RDY</u>	RDY	+ DB 2	+ AD 2	+ AD 2
47	BASP	BASP	BASP	BASP	BASP	- DB 2	- AD 2	- AD 2
48	-	EANK	EANK		-	+ RDY	+ RDY	+ RDY
49	0V	0V	0V	M	0V	- RDY	- RDY	- RDY
50	0V	0V	0V	M	0V	0V	-	-

\*For parallel communication with the IM 324U

\*\*No signal in parallel communication

## Connector Assignments

Pin No.	IM 310-3		IM 312-3	IM 312-5C		IM 314	
	Blade Connector 3	Blade Connector 4	Blade Connector 3	Blade Connector 3	Blade Connector 4	Blade Connector 3	Blade Connector 4
1	0 V <sub>ext</sub>	0 V <sub>ext</sub>	Shield	0 V <sub>ext</sub>	0 V <sub>ext</sub>		
2	+ ADB 4	+ ADB 4	-	+ 5V	+ 5V	+ AD 12	+ AD 12
3	- ADB 4	- ADB 4	-	+ 5V	+ 5V	- AD 12	- AD 12
4	+ ADB 5	+ ADB 5	-	+ 5V	+ 5V	+ AD 13	+ AD 13
5	- ADB 5	- ADB 5	+ PEU	+ 5V	+ 5V	- AD 13	- AD 13
6	+ ADB 6	+ ADB 6	- PEU	+ 5V	+ 5V	+ AD 14	+ AD 14
7	- ADB 6	- ADB 6	ADB1	ADB 1	ADB 1	- AD 14	- AD 14
8	+ ADB 7	+ ADB 7	ADB4	ADB 4	ADB 4	+ AD 15	+ AD 15
9	- ADB 7	- ADB 7	ADB7	ADB 7	ADB 7	- AD 15	- AD 15
10	+ DB 6	+ DB 6	DB1	DB 1	DB 1	+ AD 6	+ AD 6
11	- DB 6	- DB 6	DB4	DB 4	DB 4	- AD 6	- AD 6
12	+ DB 7	+ DB 7	0V	0V	0V	+ AD 7	+ AD 7
13	- DB 7	- DB 7	0V	0V	0V	- AD 7	- AD 7
14	+ PEU	+ PEU	0V	0V	0V	<u>PEUa</u>	<u>PEUe</u>
15	- PEU	- PEU	0V	0V	0V	<u>PEUa</u>	<u>PEUe</u>
16	-	5V	0V	0V	0V	-	0V
17	0 V <sub>ext</sub>	0 V <sub>ext</sub>	Shield	0 V <sub>ext</sub>	0 V <sub>ext</sub>	-	0V
18	+ ADB 0	+ ADB 0	-	+ 5V	+ 5V	+ AD 8	+ AD 8
19	- ADB 0	- ADB 0	-	+ 5V	+ 5V	- AD 8	- AD 8
20	+ ADB 1	+ ADB 1	-	+ 5V	+ 5V	+ AD 9	+ AD 9
21	- ADB 1	- ADB 1	- ZGU	+ 5V	+ 5V	- AD 9	- AD 9
22	+ ADB 2	+ ADB 2	+ ZGU	+ 5V	+ 5V	+ AD 10	+ AD 10
23	- ADB 2	- ADB 2	ADB0	ADB 0	ADB 0	- AD 10	- AD 10
24	+ ADB 3	+ ADB 3	ADB3	ADB 3	ADB 3	+ AD 11	+ AD 11
25	- ADB 3	- ADB 3	ADB6	ADB 6	ADB 6	- AD 11	- AD 11
26	+ DB 3	+ DB 3	0V	0V	0V	+ AD 3	+ AD 3
27	- DB 3	- DB 3	DB3	DB 3	DB 3	- AD 3	- AD 3
28	+ DB 4	+ DB 4	DB6	DB 6	DB 6	+ AD 4	+ AD 4
29	- DB 4	- DB 4	0V	0V	0V	- AD 4	- AD 4
30	+ DB 5	+ DB 5	0V	0V	0V	+ AD 5	+ AD 5
31	- DB 5	- DB 5	0V	0V	0V	- AD 5	- AD 5
32	+ ZGU	+ ZGU	0V	0V	0V	<u>ZGUe</u>	<u>ZGUa</u>
33	- ZGU	- ZGU	0V	0V	0V	<u>ZGUe</u>	<u>ZGUa</u>
34	+ MEMR	+ MEMR	-	+5V	+5V	+ <u>MEMR</u>	+ <u>MEMR</u>
35	- MEMR	- MEMR	-	-	-	- <u>MEMR</u>	- <u>MEMR</u>
36	+ MEMW	+ MEMW	CPKL	CPKL	CPKL	+ <u>MEMW</u>	+ <u>MEMW</u>
37	- MEMW	- MEMW	MEMR	MEMR	MEMR	- <u>MEMW</u>	- <u>MEMW</u>
38	+ PESP	+ PESP	MEMW	MEMW	MEMW	+ ALE	+ ALE
39	- PESP	- PESP	PESP	PESP	PESP	- ALE	- ALE
40	+ BASP	+ BASP	ADB2	ADB 2	ADB 2	+ BASP	+ BASP
41	- BASP	- BASP	ADB5	ADB 5	ADB 5	- BASP	- BASP
42	+ DB 0	+ DB 0	DB0	DB 0	DB 0	+ AD0	+ AD0
43	- DB 0	- DB 0	DB2	DB 2	DB 2	- AD 0	- AD 0
44	+ DB 1	+ DB 1	DB5	DB 5	DB 5	+ AD 1	+ AD 1
45	- DB 1	- DB 1	DB7	DB 7	DB 7	- AD 1	- AD 1
46	+ DB 2	+ DB 2	RDY	RDY	RDY	+ AD 2	+ AD 2
47	- DB 2	- DB 2	BASP	BASP	BASP	- <u>AD 2</u>	- <u>AD 2</u>
48	+ RDY	+ RDY	-	-	-	+ <u>RDY</u>	+ <u>RDY</u>
49	- RDY	- RDY	0V	0V	0V	- <u>RDY</u>	- <u>RDY</u>
50	-	0V	0V	0V	0V	-	+5V

# Appendix

# 11

Given in the Appendix are the

- Ordering information on products mentioned in this manual
- References for further reading

## Ordering Information

Given in this section are the order numbers for the products mentioned and/or described in the System Manual. The order numbers are arranged according to the chapters in which the corresponding products are mentioned.

### Chapter 4

<b>Central Controllers</b>	
with power supply unit 6ES5 955-3LC41 6ES5 955-3LF41 6ES5 955-3NC41 6ES5 955-3NF41	6ES5 188-3UA11 6ES5 188-3UA21 6ES5 188-3UA31 6ES5 188-3UA51
with power supply unit 6ES5 955-3NA12	6ES5 135-3UA41
<b>Expansion Units</b>	
with power supply unit 6ES5 955-3LC41	6ES5 183-3UA13 6ES5 185-3UA12
with power supply unit 6ES5 955-3LF41	6ES5 185-3UA32
with power supply unit 6ES5 955-3NC41	6ES5 183-3UA22 6ES5 185-3UA22
with power supply unit 6ES5 955-3NF41	6ES5 185-3UA42
with fan module 230/120 V AC 24 V DC	6ES5 184-3UA11 6ES5 184-3UA21
without power supply or fan module	6ES5 187-5UA11
Baffle	6ES5 981-0DA11
Dummy front plates width 1 slot width 2 slots	6XF2 008-6KB00 6XF2 016-6KB00

<b>Power Supply Units</b>	
230/120 V AC, isolated, 5 V DC/18 A	6ES5 955-3LC41
230/120 V AC, isolated, 5 V DC/40 A	6ES5 955-3LF41
24 V DC, isolated, 5 V DC/18 A	6ES5 955-3NC41
24 V DC, isolated, 5 V DC/40 A	6ES5 955-3NF41
Lithium backup battery 3.6 V	6EW1 000-7AA (with EWK LZ S2)
Rechargeable battery with two screws	6ES5 980-0NC11 (with EWK LZ S2)
Fan subassembly with fan and terminals for rechargeable battery	6ES5 988-3NB41 (with WKF RZF)
Filter holder, guides, 10 filter mats	6ES5 981-0FA41 (with WKF RZF)
Filter mats (10)	6ES5 981-0EA41 (with WKF RZF)
Battery compartment	C98130-A1155-B21
Battery compartment holder	(with WKF RZF) C98130-A1155-B20 (with WKF RZF)
Battery compartment and battery compartment holder	C98130-A1155-A7 (with WKF RZF)
Fuses for 3LC41 4 A, slow, 250 V	C97327-Z1006-C130
Fuses for 3LF41 8 A, fast, 250 V	C98327-S1001-C23
Fuses for 3NC41 20 A, super-fast, 65 V	C98327-S1001-C19
Fuses for 3NF41 30 A, super-fast, 65 V	C98327-S1001-C24 (with WKF RZF)
Caps for terminals (4)	C98130-A1102-C49 (with WKF RZF)
951 load power supply module	
230/120 V AC, isolated, 24 V/4 A	6ES5 951-4LB11
Fuse, 1 A slow	W79054-L4011-T100
Fuse, 2 A slow	W79054-L4011-T200
Front connector, 20-way for crimp connection, 40 mm	6ES5 497-4UA42
Spring contacts	6XX3 070
Front connector, 20-way for screw connection, 40 mm	6ES5 497-4UB42
24 V DC, not isolated, 10 A	6ES5 955-3NA12
15 V auxiliary submodule	6ES5 956-0AA12
Battery module	6XG3 400-2CK00
Fan unit	6ES5 988-3NA11
Backup battery	6EW1 000-7AA



## Chapter 5

<b>CPUs</b>	
CPU 948-1 (640 Kbyte user memory)	6ES5 948-3UA11
CPU 948-2 (1664 Kbyte user memory)	6ES5 948-3UA21
CPU 928B	6ES5 928-3UB12
CPU 928	6ES5 928-3UA12
CPU 922	6ES5 922-3UA11
<b>374 Memory Cards</b>	
256 Kbytes	6ES5 374-2FH21
512 Kbytes	6ES5 374-2FJ21
1028 Kbytes	6ES5 374-2FK21
2048 Kbytes	6ES5 374-2FL21
4112 Kbytes	6ES5 374-2FM21
<b>376 Memory Cards</b>	
16 Kbytes	6ES5 376-0AA11
32 Kbytes	6ES5 376-0AA21
64 Kbytes	6ES5 376-0AA31
<b>377 Memory Cards</b>	
16 Kbytes	6ES5 377-0AA11
32 Kbytes	6ES5 377-0AA21
64 Kbytes	6ES5 377-0AA32
64 Kbytes (with backup battery)	6ES5 377-0BA31
Backup battery	6ES5 980-0DA11
<b>Interface Submodules</b>	
PG submodule	6ES5 752-0AA53
TTY submodule for 20 mA current loop	6ES5 752-0AA12
V.24 (RS-232C) submodule	6ES5 752-0AA22
RS422-A/485 submodule	6ES5 752-0AA42
SINEC L1 submodule	6ES5 752-0AA62
Cover for submodule receptacle	C79458-L957-B51
BT 777 bus terminal	6ES5 777-xxx00
Standard connecting cables	
CPU 948/928B - PG 7xx	6ES5 734-2xxx0
CPU 928B - CP 544/525/524 (RS422-A/485)	6ES5 725-7xxx0
CPU 928B - CP 544/525/524 (TTY)	6ES5 726-1xxx0
CPU 928B - CP 544/525/524 (V.24)	6ES5 726-8xxx0
CPU 928B - DR 210/DR 211 DR 230/DR 231 (TTY/V.24)	6ES5 726-5xxx0
(xxx = SIMATIC length code, see Catalog)	

**Chapter 6**

<b>Coordinators</b>	
923A coordinator	6ES5 923-3UA11
923C coordinator	6ES5 923-3UC11
Coding plug	C79334-A3011-B12
Front cover	C79451-A3079-C251
Connecting cable for CP 530, 143 and 5430	
0.9 m	6ES5 725-0AK00
2.5 m	6ES5 725-0BC50

**Chapter 7**

<b>Interface Modules</b>	
IM 300-3	6ES5 300-3AB11
IM 300-5C	6ES5 300-5CA11
IM 300-5L	6ES5 300-5LB11
IM 301-3	6ES5 301-3AB13
IM 301-5	6ES5 301-5CA12
IM 304	6ES5 304-3UB11
IM 310	6ES5 310-3AB11
IM 312-3 (0.5 m)	6ES5 312-3AB11
IM 312-5 (0.95 m)	6ES5 312-3AB31
IM 312-5 (0.5 m)	6ES5 312-5CA11
IM 312-5 (1.5 m)	6ES5 312-5CA21
IM 314	6ES5 314-3UA11
IM 314R	6ES5 314-3UR11
Connecting cable (xxx = SIMATIC length code, see Catalog)	6ES5-721-0xxx
Connecting cable for IM 300-5LB11	
Length 0.5 m	6ES5 705-0AF00
Length 1.5 m	6ES5 705-0BB0
Terminator	
for IM 314	6ES5 760-1AA11
for IM 312 and IM 301-3	6ES5 760-0AB11
for IM 301-3	6ES5 760-0AA11

## Chapter 8

<b>Digital Input/Output Modules</b>	
Modules	Adhesive Label
6ES5 420-4UA13	C79451-A3079-C751
6ES5 430-4UA13	C79451-A3079-C752
6ES5 431-4UA12	C79451-A3079-C732
6ES5 432-4UA12	C79451-A3079-C733
6ES5 434-4UA12	C79451-A3079-C734
6ES5 435-4UA12	C79451-A3079-C735
6ES5 436-4UA12	C79451-A3079-C736
6ES5 436-4UB12	C79451-A3079-C737
6ES5 441-4UA13	C79451-A3079-C753
6ES5 451-4UA13	C79451-A3079-C755
6ES5 453-4UA12	C79451-A3079-C740
6ES5 454-4UA13	C79451-A3079-C756
6ES5 455-4UA12	C79451-A3079-C742
6ES5 456-4UA12	C79451-A3079-C743
6ES5 456-4UB12	C79451-A3079-C744
6ES5 457-4UA12	C79451-A3079-C727
6ES5 458-4UA12	C79451-A3079-C745
6ES5 458-4UC11	E89100-B2749-C100
6ES5 482-4UA11	C79451-A3079-C749
<b>Front Connectors</b>	
Crimp terminals, single-width, 42-way	6ES5 497-4UA12
Crimp terminals, double-width, 42-way	6ES5 497-4UA22
Crimp terminals, double-width, 20-way	6ES5 497-4UA42
Screw terminals, single-width, 42-way	6ES5 497-4UB31
Screw terminals, double-width, 42-way	6ES5 497-4UB12
Screw terminals, double-width, 25-way	6ES5 497-4UB22
Screw terminals, double-width, 20-way	6ES5 497-4UB42

IP 257	6ES5 257-4UA11
Local bus for DI/DQ 482	6ES5 751-2AA11

Mini spring contacts (250 single contacts)	6XX3070
Crimping tool	6XX3071
Ferrules to DIN 46228	
Extraction (releasing) tool	6ES5 497-4UC11
Set of labels for addresses	6ES5 497-4UD11
Coding jumper (to change over the enable mode)	W79070-G2602-N2

Fuse for 6ES5 456-4UB12 3.5 A, fast/250 V UL/CSA	W79054-L1021-F350
Fuse for 6ES5 455-4UA12 and 6ES5 455-4UA12 6.3 A, fast/250 V	W79054-L1011-F630
Fuse for 6ES5 482-4UA11 6.3 A/125 V	W79054-M1041-T630
Light guide K for front connector with crimp terminal	6ES5 497-4UL11
Light guide S for front connector with screw terminal	6ES5 497-4UL21

## Chapter 9

<b>Analog Input/Output Modules</b>	
Modules	Adhesive Labels
6ES5 460-4UA13	C79451-A3079-C723
6ES5 463-4UA12	C79451-A3079-C746
6ES5 465-4UA12	C79451-A3079-C748
6ES5 470-4UA12	C79451-A3079-C724
6ES5 470-4UB12	C79451-A3079-C725
6ES5 470-4UC12	C79451-A3079-C726
<b>Front Connectors</b>	
Crimp terminals, single-width, 42-way	6ES5 497-4UA12
Crimp terminals, double-width, 42-way	6ES5 497-4UA22
Crimp terminals, double-width, 20-way	6ES5 497-4UA42
Screw terminals, single-width, 42-way	6ES5 497-4UB31
Screw terminals, double-width, 42-way	6ES5 497-4UB12
Screw terminals, double-width, 25-way	6ES5 497-4UB22
Screw terminals, double-width, 20-way	6ES5 497-4UB42

Mini spring contacts (250 single contacts)	6XX3070
Crimping tool	6XX3071
Ferrules to DIN 46228	
Extraction (releasing) tool	6ES5 497-4UC11
Set of labels for addresses	6ES5 497-4UD11

Range Cards		
Modules	Features	Range Card
6ES5 460-4UA13 6ES5 465-4UA12	± 12.5/50/500mV/Pt 100 ± 50/500mV/Pt 100 ± 1V ± 5V ± 10V ± 20mA 4 to 20 mA/2-wire transducer 4 to 20 mA/4-wire transducer	6ES5 498-1AA11 6ES5 498-1AA11 6ES5 498-1AA21 6ES5 498-1AA61 6ES5 498-1AA31 6ES5 498-1AA41 6ES5 498-1AA51  6ES5 498-1AA71

## Further Reading

Hans Berger:  
Automating with the SIMATIC S5-135U  
Siemens AG A19100-L531-F505-X-7600

Hans Berger:  
Automating with the SIMATIC S5-155U  
Siemens AG A19100-L531-F177-X-7600

Catalog ST 54.1 Programmable Controllers  
S5-135U, S5-155U and S5-155H

Catalog ST 50 SIMATIC S5  
Programmable Controllers

Catalog ST 59 SIMATIC S5  
Programmable Controllers

Catalogs ET 1.4 and ET 3 6ES7 Power Supply Units

Guidelines for Handling  
Electrostatically Sensitive Devices:  
at the end of this manual

S5-155U Programmable Controller  
CPU 948  
Programming Guide  
6ES5 998-3PR21

S5-135U Programmable Controller  
CPU 928B  
Programming Guide  
6ES5 988-2PR21

S5-135U Programmable Controller  
CPU 928B  
Communication  
6ES5 998-2UL22

S5-135U Programmable Controller  
CPU 928  
Programming Guide  
6ES5 998-1PR21

S5-135U Programmable Controller  
CPU 922  
Programming Guide  
6ES5 998-0PR21

STEP 5  
C79000-G8576-C140

IP 257  
6ES5 998-2EA21

# Index

# 12



## Index

### A

Address label .....	8-23
Addressing	
cyclic sampling .....	9-14, 9-109
selective sampling .....	9-14, 9-61, 9-109
Addressing switch	
analog input/output modules .....	9-6, 9-37, 9-53, 9-103
digital input/output modules .....	8-6
Air filter .....	4-76
Application	
COR 923A .....	6-17
COR 923C .....	6-20
CPU 922 .....	5-43
CPU 928 .....	5-33
CPU 928B .....	5-21
CPU 948 .....	5-6
Auxiliary submodule	
15 V auxiliary submodule .....	4-75

### B

Backup battery	
377 memory submodules .....	5-60
power supply units .....	4-34
PSU 6ES5 955-3NA12 .....	4-78
Base address .....	6-27
setting .....	6-24
Basic functions	
of the power supply units .....	4-22
BASP	
analog input modules .....	9-11, 9-58, 9-107
digital input module .....	8-5
digital output modules .....	8-5
BASP signal .....	6-16
Battery voltage .....	4-70
of the power supply units .....	4-24
of the PSU 6ES5 955-3NA12 .....	4-70
Broken wire monitoring	
extended Pt 100 measuring range .....	9-24, 9-69
Broken wire signal .....	9-10, 9-57
Bus arbitration .....	6-17 - 6-18, 6-20 - 6-21
Bus enable .....	6-18, 6-21
Bus enable assignment .....	6-18
sequence .....	6-22
Bus enable signal .....	6-18, 6-21
Bus lock signal .....	6-22
Bus PCB .....	4-5

**C**

Cabinet assembly	
for EMC .....	3-10
Cable duct.....	4-5
Cables	
of the power supply units .....	4-30
Central controller	
installing .....	4-8
Central grounding .....	3-26
Central programmer connection .....	6-20
Check list	
EMC measures.....	3-21
Communication flag area .....	6-9
Communication flag areas	
setting.....	6-8
Communication flag byte	
address .....	6-9
Communication flags .....	6-17, 6-19, 6-23
Communication memory .....	6-17, 6-19 - 6-20, 6-23
addressing .....	6-8
Compensating box	
connection.....	9-21, 9-66
Connecting loads.....	9-114 - 9-115
Connecting sensors .....	9-93
Connector assignment	
coordinator 923 A.....	10-17
coordinator 923 C.....	10-18
CPU 922 .....	10-15
CPU 928 .....	10-14
CPU 928B.....	10-13
CPU 948 .....	10-12
front connector of the CPUs (PG interface).....	10-16
front connectors of the coordinators.....	10-19
power supply units.....	10-10
PSU 6ES5 955-3NA12.....	10-11
Connector assignments .....	4-64
IMs .....	10-20
Connector assignments of the backplane	
EU 183U; EU 184U; EU 187U .....	10-6
EU 185U .....	10-7
S5-135U/155U CC .....	10-3
Controls and indicators	
24 V/ 4 A load power supply.....	4-63
COR 923C .....	6-25
CPU 922 .....	5-46
CPU 928 .....	5-36
CPU 928B.....	5-26
CPU 948 .....	5-10
IM 300 .....	7-6
IM 301 .....	7-12
IM 304 .....	7-16
power supply units.....	4-25
PSU 6ES5 955-3NA12.....	4-70

Coordinator	
location of jumper sockets .....	6-6
modes .....	6-15
normal operation .....	6-15
stop in the event of fault .....	6-15
test mode .....	6-16
COR 923A .....	6-8
application .....	6-17
design .....	6-17
mode switch .....	6-19
principle of operation .....	6-18
COR 923C .....	6-8, 6-14, 6-17
activating addresses .....	6-27
application .....	6-20
controls .....	6-25
design .....	6-21
indicators .....	6-25
principle of operation .....	6-21
setting the coordination section .....	6-26
setting the DIL switcher .....	6-26
setting the PG multiplexer .....	6-27
switching off the coordination signal .....	6-29
Coupling	
capacitive coupling .....	3-6
direct coupling .....	3-6
inductive coupling .....	3-6
mechanisms .....	3-5
radiated interference .....	3-6
Current limiting	
two-wire transducers .....	9-48
Current sensors	
connection .....	9-19
Current/voltage measurement .....	9-82
Cyclic program processing .....	6-15 - 6-16
Cyclic sampling .....	9-10, 9-57
<b>D</b>	
Data format	
setting .....	9-50, 9-85
Design	
COR 923A .....	6-17
COR 923C .....	6-21
CPU 922 .....	5-43
CPU 928 .....	5-33
CPU 928B .....	5-21
CPU 948 .....	5-7
Differential measurement .....	9-82, 9-93
Double addressing .....	6-8, 6-24

**E**

Electrical connection with process I/Os.....	3-25
Electromagnetic compatibility .....	3-4
EMC measures	
specific .....	3-19
EMC, basic rules .....	3-7
Enable circuit	
digital input/output modules .....	8-6
Enable input .....	9-7, 9-38, 9-54, 9-104
switching off .....	9-104
Enable inputs	
functioning .....	8-8
Enable switching off .....	9-7, 9-38, 9-54
Enable time.....	6-18, 6-21
Equipotential bonding conductor.....	3-16, 9-19
Example of an electrical installation.....	3-25

**F**

Fan .....	4-5
failure .....	4-53
Fan	
removing .....	4-36
replacing .....	4-45, 4-79
Fan lock, releasing .....	4-36
Fault indications	
load power supply.....	4-66
power supply units.....	4-39
PSU 6ES5 955-3NA12 .....	4-77
Fault register.....	6-29
FB 40 function block .....	9-11, 9-58
Filter mat	
replacing .....	4-49
Filter subdrawer	
fitting.....	4-37
Floating modules.....	3-29
Four-wire circuit.....	9-115
Front connector .....	4-11, 6-21
463 analog input module .....	9-51
466 analog input module .....	9-101
Front plate .....	6-21
CPU 922 .....	5-46
CPU 928 .....	5-36
CPU 928B.....	5-26
CPU 948 .....	5-10
power supply units.....	4-24
PSU 6ES5 955-3NA12.....	4-70
Front plate width .....	6-17, 6-21
Front strip	
24 V/4 A load power supply.....	4-64
Full duplex operation	
RS422-A/485 submodule .....	5-85

Function block.....	9-107
Fusing .....	3-23, 8-27

**G**

Global memory access .....	6-17
Grounding	
distributed arrangement of monitor and PLC.....	3-33
inactive metal parts.....	3-7, 3-9
PLCs .....	3-25

**I**

I/O byte	
changeover, DI/DQ 482.....	8-15
I/O modules.....	8-4
analog input/output modules .....	9-4
digital input/output modules.....	8-4
Individual locking .....	4-5
Inductive loads .....	8-28
Inputs/outputs	
24 V/4 A load power supply.....	4-62
power supply units.....	4-24
PSU 6ES5 955-3NA12.....	4-71
Interchange of data.....	6-17
Interface submodules	
installing .....	5-66
PG submodule .....	5-68
removing.....	5-67
RS422-A/485 submodule .....	5-85
SINEC L1 submodule .....	5-91
TTY submodule.....	5-79
use.....	5-65
V.24 submodule.....	5-72
Interfaces	
CPU 928B.....	5-22
CPU 948 .....	5-17
Interference.....	3-4
Interference source .....	3-6
Interference-free installation	
centralized interface circuits.....	3-30
distributed interface circuits .....	3-30

**J**

Jumper settings	
COR 923A .....	6-6
COR 923C .....	6-7, 6-29
CPU 928B.....	5-24
CPU 948 .....	5-8
IM 300-3 .....	7-7
IM 300-5 .....	7-8 - 7-9
IM 301 .....	7-13
IM 304 .....	7-17

IM 314 .....	7-19
PG submodule .....	5-70
power supply units .....	4-28
PSU 6ES5 955-3NA12 .....	4-72
RS422-A/485 submodule .....	5-87
SINEC L1 submodule .....	5-93
TTY submodule .....	5-81
V.24 submodule .....	5-74
<b>L</b>	
Labelling field .....	8-17, 9-12, 9-41, 9-59, 9-107
LEDs	
COR 923C .....	6-25
CPU 922 .....	5-49
CPU 928 .....	5-39
CPU 928B .....	5-28
CPU 948 .....	5-13
digital input/output modules .....	8-6
load power supply .....	4-63
power supply units .....	4-39
PSU 6ES5 955-3NA12 .....	4-77
LEDs for fault indication and signalling	
CPU 922 .....	5-49
CPU 928 .....	5-39
CPU 928B .....	5-28
CPU 948 .....	5-13
Lightning protection .....	3-15
Line groups .....	3-7
Lithium battery	
fitting in PSU .....	4-34
replacing .....	4-44
Load circuit	
disconnecting .....	8-29
Load power supply .....	3-22
application .....	4-61
design .....	4-61
Load voltage .....	9-48
Location of jumpers	
power supply units .....	4-32
PSU 6ES5 955-3NA12 .....	4-72
Locking bar .....	4-5
<b>M</b>	
Main switch .....	3-23
Measured-value representation	
current measuring range 4 to 20 mA .....	9-30, 9-74
different measuring ranges .....	9-95
output current/voltage .....	9-116
Pt 100 .....	9-28, 9-73
two's complement .....	9-26, 9-71
value and sign .....	9-27, 9-72
Measurement with respect to ground .....	9-82, 9-92

Measuring range	
466 analog input module .....	9-81
setting .....	9-84
Measuring range exceeded .....	9-10, 9-57
Memory cards 374 .....	5-53
erasing .....	5-53
inserting .....	5-53
programming .....	5-53
Memory page .....	6-23
Memory submodules 376 .....	5-55
erasing .....	5-56
inserting .....	5-56
programming .....	5-55
Memory submodules 377 .....	5-57
backup battery .....	5-60
inserting .....	5-61
programming .....	5-57
removing .....	5-62
with battery backup .....	5-58
Mode	
setting .....	9-33, 9-76
Mode switch .....	6-19, 6-25, 9-6, 9-37, 9-53
coordinator .....	6-15
COR 923A .....	6-19
COR 923C .....	6-25
CPU 922 .....	5-47
CPU 928 .....	5-37
CPU 928B .....	5-27
CPU 948 .....	5-11
Module	
mounting width .....	4-10
Momentary-contact mode switch	
CPU 922 .....	5-47
CPU 928 .....	5-37
CPU 928B .....	5-27
CPU 948 .....	5-11
Monitor connection .....	3-32 - 3-34
Monitoring for bus assignment .....	6-22
Monitoring function .....	4-22
Mounting in cabinets .....	3-10
Mounting on racks .....	3-12
Mounting on walls .....	3-12
Multiplex interface .....	6-24
Multiprocessor operation .....	1-1, 6-4, 6-17
starting .....	6-5
startup phase .....	6-14
<b>N</b>	
Non-floating modules .....	3-28

**O**

Operator functions.....	6-17
Outputs	
parallel connection.....	8-25
Overall reset	
CPU 922 .....	5-47, 5-50
CPU 928 .....	5-37, 5-40
CPU 928B.....	5-27, 5-30
CPU 948 .....	5-11, 5-15

**P**

Page memory.....	6-23
PG Interfaces	
CPU 928B.....	5-22
CPU 948 .....	5-17
PG multiplexer	
of COR 923C.....	6-24
PG MUX .....	6-29
PG submodule .....	5-68
Pin assignments	
PG submodule .....	5-69
RS422-A/485 submodule .....	5-86
SINEC L1 submodule .....	5-92
TTY submodule.....	5-80
V.24 submodule.....	5-73
Power dissipation	
in cabinets .....	3-38
Power supplies	
AC.....	3-24
centrally grounded.....	3-26
control circuits .....	3-22
grounded .....	3-25
load circuits.....	3-22
ungrounded .....	3-27
Power supply	
failure.....	4-52
Power supply	
for programmable controller .....	3-20
Power supply types .....	4-21
Power supply unit.....	4-5
connecting.....	4-26
fitting.....	4-33
removing.....	4-31
replacing .....	4-50
setting.....	4-26
Power supply unit	
switching on.....	4-38
Process inputs	
scanning .....	8-11, 8-13



Process interrupt processing	
CPU 922 .....	5-44
CPU 928 .....	5-34
CPU 928B.....	5-24
Processing levels	
CPU 922 .....	5-43
CPU 928 .....	5-33
CPU 928B.....	5-21
CPU 948 .....	5-6
Programmable controller	
power supply.....	3-20, 3-26
validity check.....	4-13
Pt 100 measuring range.....	9-28
<b>Q</b>	
Quenching circuitry.....	8-28
Quenching devices	
selection, connection .....	8-29
<b>R</b>	
Radiated interference .....	3-6
Rechargeable battery	
connecting.....	4-36
replacing .....	4-47
Reference potential.....	3-8
Removing and inserting	
CPU 922 .....	5-45
CPU 928 .....	5-35
CPU 928B.....	5-24
CPU 948 .....	5-9
modules.....	8-21, 9-15, 9-44, 9-62, 9-88, 9-110
Replacing the battery	
of the power supply units .....	4-44
of the PSU 6ES5 955-3NA12.....	4-78
Reset	
automatic.....	6-15
CPU 922 .....	5-47, 5-50
CPU 928 .....	5-37, 5-40
CPU 928B.....	5-27, 5-30
CPU 948 .....	5-11, 5-15
Resistance thermometer	
connection.....	9-22
Restart	
automatic.....	6-15
CPU 922 .....	5-47, 5-50
CPU 928 .....	5-37, 5-40
CPU 928B.....	5-27
CPU 948 .....	5-11
Routing of lines .....	3-7
RS422-A/485 submodule.....	5-85

**S**

S5 bus .....	6-18
Selective sampling .....	9-11, 9-57
Semaphores .....	6-19, 6-23
Sensors	
connection.....	9-50, 9-93
Serial interface .....	6-24
selection method.....	6-24
Setting the voltage selector switch.....	4-37, 4-65
Shielding .....	3-17
distributed arrangement of monitor and PLC.....	3-33
Shielding of cables/lines .....	3-17
Short-circuit protection .....	8-27
Signal lines	
connection.....	8-24, 9-18, 9-47, 9-65, 9-91, 9-113
Signal output .....	8-5
Signalling circuits	
of the power supply units .....	4-29
Signalling function	
of the power supply units .....	4-23
SINEC H1 LAN	
routing of cables .....	3-14
SINEC L1 LAN	
routing of cables .....	3-14
SINEC L1 submodule .....	5-91
SINEC L2 LAN	
routing of cables .....	3-14
Slot .....	6-24
setting the number of CPU slots.....	6-8
slots required by CPU.....	1-1, 6-4
Standard connecting cables	
PG submodule .....	5-71
RS422-A/485 submodule .....	5-90
TTY submodule.....	5-82
V.24 submodule.....	5-75
Start .....	6-15
manual.....	6-15
Start address .....	8-18
Start address, subaddress	
analog input/output modules .....	9-12, 9-41, 9-59, 9-108
Startup	
CPU 922 .....	5-50
CPU 928 .....	5-40
CPU 928B.....	5-30
CPU 948 .....	5-15
Startup of CC	
brief instructions .....	4-12
Startup of the programmable controller.....	4-12
Station number .....	6-24
Status indicators	
CPU 922 .....	5-48
CPU 928 .....	5-38
CPU 928B.....	5-28

CPU 948 .....	5-12
Stop state .....	6-15
Supply line L+ and L disconnecting .....	8-29
Systems installation to EMC requirements .....	3-4
<b>T</b>	
Technical specifications	
374 memory cards .....	5-54
376 memory submodules .....	5-56
377 memory submodules .....	5-63
420 digital input module .....	8-33
430 digital input module .....	8-35
431 digital input module .....	8-37
432 digital input module .....	8-39
434 digital input module .....	8-42
435 digital input module .....	8-45
436-4UA12 digital input module .....	8-47
436-4UB12 digital input module .....	8-49
441 digital output module .....	8-51
451 digital output module .....	8-53
453 digital output module .....	8-55
454 digital output module .....	8-57
455 digital output module .....	8-59
456 4UB12 digital output module .....	8-63
456-4UA12 digital output module .....	8-61
457 digital output module .....	8-65
458 4UA12 digital output module .....	8-67
458-4UC11 digital output module .....	8-70, 8-72
coordinators .....	6-30
CPU 922 .....	5-51
CPU 928 .....	5-41
CPU 928B .....	5-31
CPU 948 .....	5-18
expansion units .....	4-20
interface modules .....	7-22
interface submodules .....	5-95
load power supply .....	4-67
power supply units .....	4-54
PSU 6ES5 955-3NA12 .....	4-80
Time-controlled program processing .....	9-11, 9-58
Time-division multiplex operation .....	6-18, 6-21
Transducers connection .....	9-25, 9-70
Tripping current .....	9-10, 9-57
TTY submodule .....	5-79
Two-wire switches .....	8-30

## Index

---

### V

V.24 interface .....	5-72
V.24 submodule .....	5-72
Vector register .....	6-23
Voltage sensors connection .....	9-19

### W

Wall mounting .....	3-13
Wiring .....	8-22

**Siemens AG**  
**AUT 1282**  
**Östliche Rheinbrückenstr. 50**  
**D-76181 Karlsruhe**  
**Federal Republic of Germany**

**From:**

Your Name: .....

Your Title: .....

Company Name: .....

Street: .....

City, Zip Code: .....

Phone: .....

Please check any industry that applies to you:

- |  |   |
|--|---|
| <input type="checkbox"/> Automotive              | <input type="checkbox"/> Pharmaceutical |
| <input type="checkbox"/> Chemical                | <input type="checkbox"/> Plastic        |
| <input type="checkbox"/> Electrical Machinery    | <input type="checkbox"/> Pulp and Paper |
| <input type="checkbox"/> Food                    | <input type="checkbox"/> Textiles       |
| <input type="checkbox"/> Instrument and Control  | <input type="checkbox"/> Transportation |
| <input type="checkbox"/> Nonelectrical Machinery | <input type="checkbox"/> Other          |
| <input type="checkbox"/> Petrochemical           |   |



