

SM-UART-04L Laser Dust Sensor

Connector

Sensor Connector:

CJT A1276WVA-N-2x5P-H72

Equivalent Connector:

Harwin, Inc. M50-3000545; Amphenol FCI 20021311-00010T4LF

Pin #	Pin Name	Description
1	5V	Input Supply Voltage
2	5V	Input Supply Voltage
3	GND	Ground
4	GND	Ground
5	RESET	Reset Pin @3.3V TTL, Low level reset
6	NC	—
7	RXD	UART Receiver @ 3.3V TTL
8	NC	—
9	TXD	UART Transceiver @ 3.3V TTL
10	SET/SLEEP	Working Mode Pin @ 3.3V TTL Floating or high level for normal working condition. Low level for dormancy mode.

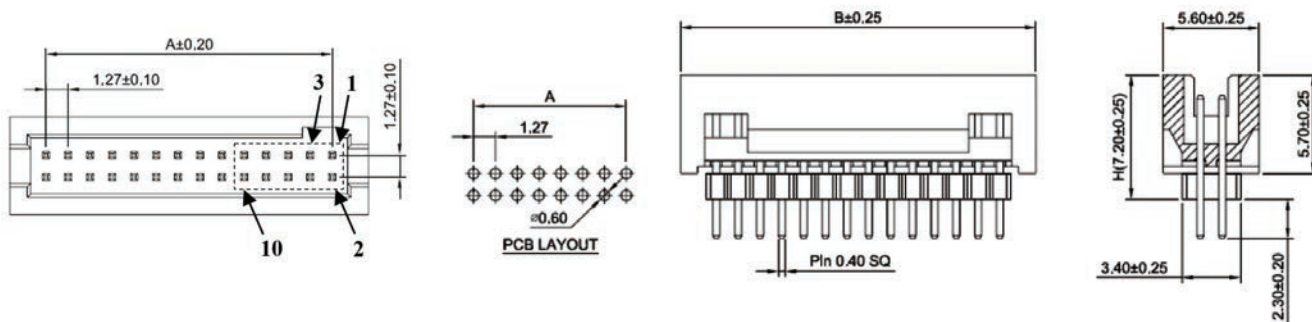

Application Circuit

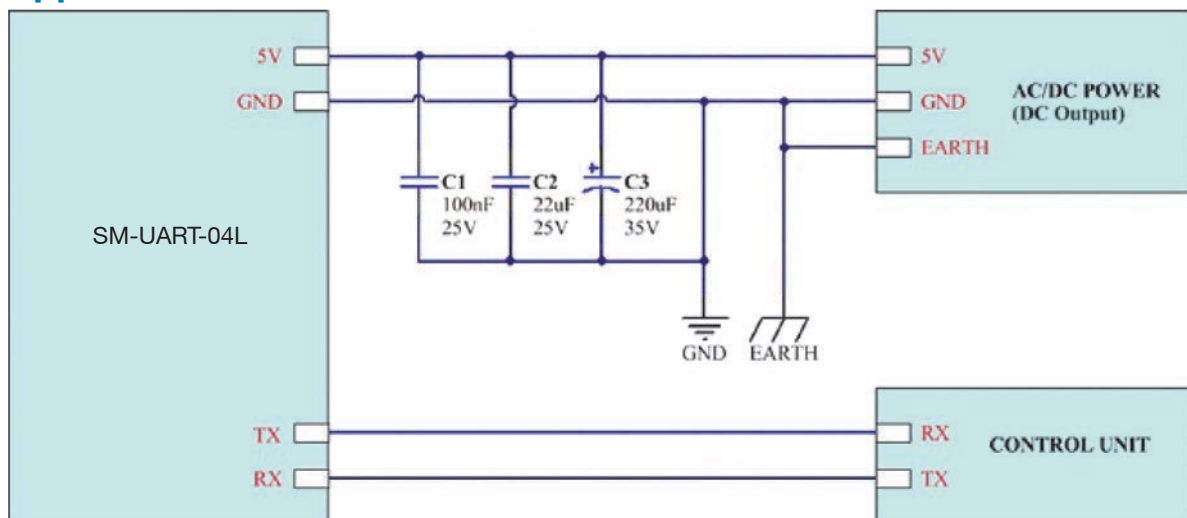

Application circuit

SM-UART-04L Laser Dust Sensor - Communication Protocol

UART

UART Serial Configuration	
Baud Rate	9600 bps
Data Bits	8
Parity	None
Stop Bits	1

Default Output UART Frame Format

Head 1	0x42	
Head 2	0x4D	
H_Length	...	Length = 2 * 13 + 2 (Data+CS)
L_Length	...	
H_D1	...	PM1 = H_D1 * 256 + L_D1 ug/m3 (Standard Smoke, Calculated Value)
L_D1	...	
H_D2	...	PM2.5 = H_D2 * 256 + L_D2 ug/m3 (Standard Smoke, Calculated Value)
L_D2	...	
H_D3	...	PM10 = H_D3 * 256 + L_D3 ug/m3 (Standard Smoke, Calculated Value)
L_D3	...	
H_D4	...	PM1 = H_D4 * 256 + L_D4 ug/m3 (Environment, Calculated Value)
L_D4	...	
H_D5	...	PM2.5 = H_D5 * 256 + L_D5 ug/m3 (Environment, Calculated Value)
L_D5	...	
H_D6	...	PM10 = H_D6 * 256 + L_D6 ug/m3 (Environment, Calculated Value)
L_D6	...	
H_D7	...	
L_D7	...	
H_D8	...	
L_D8	...	
H_D9	...	
L_D9	...	
H_D10	...	
L_D10	...	
H_D11	...	
L_D11	...	
H_D12	...	
L_D12	...	
H_D13	...	Version number
L_D13	...	Error code 0b0ABCDEFGG A = 1 Laser error B = 1 Laser alarm C = 1 High temperature alarm D = 1 Low temperature alarm E = 1 Fan error F = 1 Fan speed compensation start G = 1 Fan speed alarm
H_CS	...	CS = HEAD1 + HEAD2 + ... + L_D13
L_CS	...	

* We recommend the customers use PM values with the standard smoke.