

# L-force *Drives*

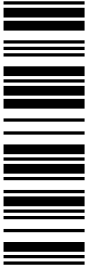

Translation **Hardware Manual**

## 8400 motec 0.37 ... 7.5 kW

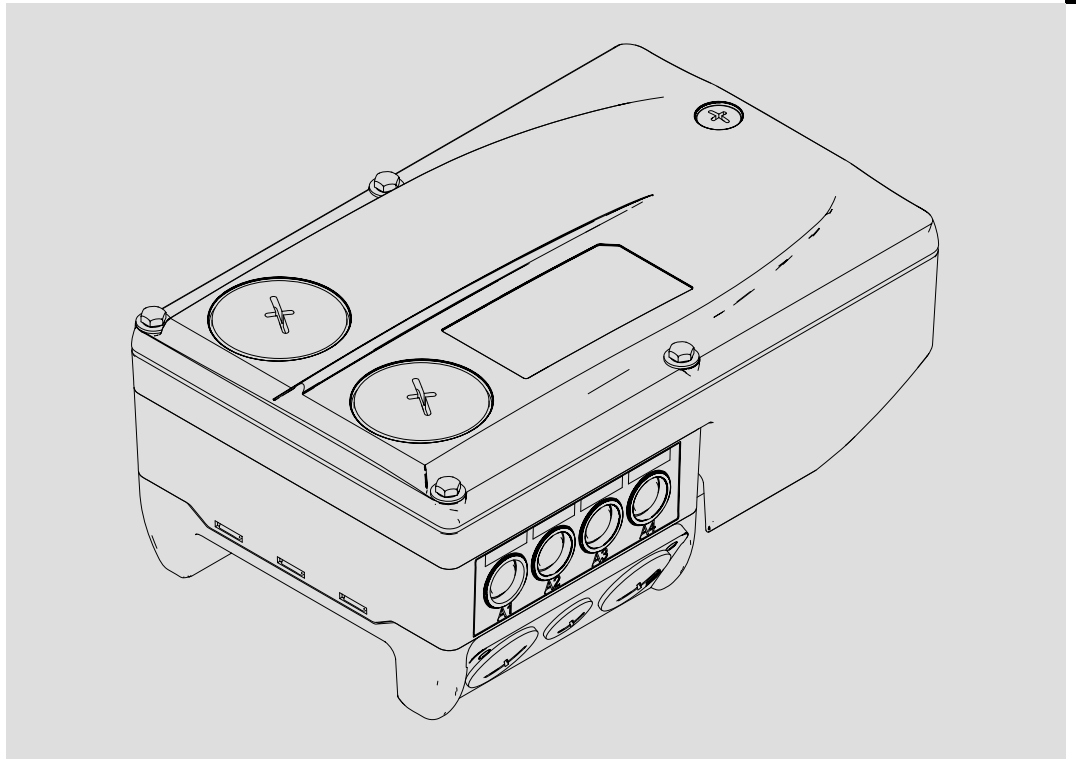

**E84DGxxxxxxxxx**

**Decentralised frequency inverter**



<b>1</b>	<b>About this documentation</b> .....	<b>7</b>
1.1	Validity information .....	7
1.2	Document history .....	8
1.3	Conventions used .....	9
1.4	Terms and abbreviations used .....	10
1.5	Notes used .....	11
<b>2</b>	<b>Safety instructions</b> .....	<b>12</b>
2.1	General safety and application notes for Lenze controllers .....	12
2.2	General safety and application instructions for Lenze motors .....	15
2.3	Residual hazards .....	18
<b>3</b>	<b>Product description</b> .....	<b>19</b>
3.1	System overview .....	19
3.2	Device features .....	20
3.3	Identification .....	21
3.4	Type code .....	22
3.4.1	Introducing information .....	22
3.4.2	The type codes .....	22
3.5	Overview of control terminals .....	25
<b>4</b>	<b>Technical data</b> .....	<b>26</b>
4.1	General data and operating conditions .....	26
4.2	Rated data .....	31
4.2.1	Overview .....	31
4.2.2	Operation at rated mains voltage 400 V .....	33
4.2.3	Operation at increased rated power at 400 V mains voltage .....	35
4.2.4	Operation with rated mains voltage 480 V .....	37
4.3	Switching frequency reduction .....	39
4.4	Overcurrent operation .....	40
4.5	Terminal description .....	42
4.5.1	Overview .....	42
4.6	Power terminals .....	44
4.6.1	Mains connection .....	45
4.6.2	Motor connection .....	45
4.6.3	Motor temperature monitoring .....	45
4.6.4	Motor holding brake connection .....	45
4.6.5	Connection of brake resistor .....	45

4.7	Control terminals .....	46
4.7.1	Digital inputs .....	48
4.7.2	Digital output .....	50
4.7.3	Analog input .....	50
4.7.4	Connection of relay output .....	50
4.7.5	Communication connection .....	51
4.8	Dimensions .....	52
4.8.1	Standard motor mounting .....	52
4.8.2	Wall mounting .....	53
<b>5</b>	<b>Installation .....</b>	<b>54</b>
5.1	Important notes .....	54
5.2	Installation according to EMC (installation of a CE-typical drive system) .....	56
5.2.1	Shielding .....	56
5.2.2	Motor cable .....	57
5.2.3	Control cables .....	58
5.2.4	Detecting and eliminating EMC interferences .....	59
5.3	Mechanical installation .....	60
5.4	Electrical installation .....	61
5.4.1	Power connections .....	61
5.4.2	Wiring of control connections .....	62
5.5	Installation of 8400 motec pre-assembled on the motor .....	64
5.5.1	Plug at the Wiring Unit .....	64
5.5.2	Attaching the cable gland .....	65
5.6	Retrofitting the 8400 motec controller .....	67
5.6.1	Preparing a motor for the 8400 motec installation .....	67
5.6.2	Mounting the Wiring Unit .....	68
5.6.3	Mounting of the Communication Unit .....	69
5.6.4	Settings at the Drive Unit .....	70
5.6.5	Mounting of the Drive Unit .....	70
5.7	Measures when drive is used in IT systems .....	72
5.8	Wall mounting of 8400 motec controller .....	73
<b>6</b>	<b>Commissioning .....</b>	<b>74</b>
6.1	Before switching on .....	74
6.2	Quick commissioning .....	76
6.2.1	General configuration settings .....	77
6.2.2	Commissioning steps .....	83
6.3	Handling of the keypad .....	84
6.4	Overview of the commissioning steps with keypad .....	87
6.4.1	Keypad control .....	87
6.4.2	Short overview of the parameters for quick commissioning .....	91

6.5	Setting with the diagnosis terminal (keypad) .....	92
6.6	Diagnostics .....	93
6.6.1	Drive diagnostics via the integrated display .....	93
6.6.2	Diagnostic codes .....	93
<b>7</b>	<b>Braking operation .....</b>	<b>94</b>
7.1	Braking operation without additional measures .....	94
7.2	Braking operation with brake resistor .....	95
7.2.1	Selection of the brake resistors .....	95
7.2.2	Wiring of brake resistor .....	96
7.3	Operation with spring-applied brake .....	99
7.3.1	Introduction .....	99
7.3.2	Wiring .....	99
<b>8</b>	<b>Safety engineering .....</b>	<b>100</b>
8.1	Introduction .....	100
8.2	Important notes .....	101
8.2.1	Hazard and risk analysis .....	102
8.2.2	Standards .....	102
8.3	Basics for safety sensors .....	103
8.4	Operating mode .....	104
8.4.1	Introduction .....	104
8.4.2	Disconnecting paths .....	104
8.4.3	Safety status .....	105
8.5	Technical data .....	106
8.6	Electrical installation .....	108
8.7	Certification .....	109
<b>9</b>	<b>Accessories (overview) .....</b>	<b>110</b>
9.1	Adapter plates (accessories) .....	110
9.2	Plug connectors .....	111
9.3	Internal brake resistors .....	112
9.4	External brake resistors .....	113
9.5	Communication modules .....	114
9.5.1	CANopen .....	114
9.5.2	PROFIBUS .....	114
9.5.3	AS interface .....	114
9.5.4	PROFINET .....	115
9.5.5	EtherCAT .....	115
9.5.6	EtherNet/IP .....	115
9.6	Keypad .....	116

9.7	Safety engineering .....	117
<b>10</b>	<b>Appendix .....</b>	<b>118</b>
10.1	Total index .....	118

# 1 About this documentation

## 1.1 Validity information

### Contents

This Hardware Manual informs you how to use the motec version of the 8400 controller series as directed.

### Validity

Type	Type designation	from hardware version	from software version
8400 motec	E84DGDVNxxxx2xS	VA	01.00
Accessories of 8400 motec	E84DG...	--	--

### Target group

This Hardware Manual is intended for all persons who design, install, commission, and adjust controllers of the 8400 Inverter Drives product range.



### Tip!

Information and auxiliary devices related to the Lenze products can be found in the download area at <http://www.Lenze.com>

# 1 About this documentation

## Document history

### 1.2 Document history

Material number	Version			Description
13410318	4.0	06/2012	TD15	General revision, supplements, and corrections
13394702	3.0	11/2011	TD15	Extension 4 ... 7.5 kW
13373547	2.0	04/2011	TD15	Extension 2.2 ... 3 kW, PROFINET, EtherCAT
13368432	1.1	01/2011	TD15	General revision, supplements, and corrections
13336684	1.0	09/2010	TD15	First edition



### 1.3 Conventions used

This documentation uses the following conventions to distinguish between different types of information:

#### Spelling of numbers

Decimal separator	Point	In general, the decimal point is used. For instance: 1234.56
-------------------	-------	---





#### Warnings

UL warnings		Are only given in English.
UR warnings		

#### Text

Program name	» «	PC software For example: »Engineer«, »Global Drive Control« (GDC)
--------------	-----	--

#### Icons

Page reference		Reference to another page with additional information For instance:  16 = see page 16
Documentation reference		Reference to another documentation with additional information For example:  EDKxxx = see documentation EDKxxx

# 1 About this documentation

## Terms and abbreviations used

### 1.4 Terms and abbreviations used

<b>Term</b>	<b>Meaning</b>
Device size	Used as generic term for a group of devices which have the same dimensions (depth, height and width) but different power ratings.
Standard device	Used as generic term when actions and features are described which are very similar or the same for different versions or device sizes, e.g. <ul style="list-style-type: none"><li>• mechanical installation or</li><li>• power terminals</li></ul>
DU	Drive unit 8400 motec controller
CU	Communication unit Optional interfaces per I/O, fieldbus, safety system
WU	Wiring unit Ready-made motor connection, replaces the motor terminal box

<b>Abbreviation</b>	<b>Meaning</b>
24O	24 V voltage supply for non-safe monitoring
Cat.	Category according to EN 954-1 (valid until 30 November 2009)
DO	Non-safe feedback output
F-PLC	Safety PLC
GSDML	File containing device-specific data to establish PROFINET communication
GSE	File containing device-specific data to establish PROFIBUS communication
OFF state	Signal status of the safety sensors when they are activated or respond
ON state	Signal status of the safety sensors during normal operation
Opto supply	Optocoupler supply for controlling the drivers
OSSD	Output Signal Switching Device, tested signal output
PELV	Protective Extra Low Voltage
PL	Performance Level according to EN ISO 13849-1
PM	P/N switching signal paths
PP	P/P switching signal paths
PS	PROFIsafe
PWM	Pulse Width Modulation
S-Bus	Safety bus
SD-In	Safe input (Safe Digital Input)
SD-Out	Safe output (Safe Digital Output)
SELV	Safety Extra Low Voltage
SIA, SIB	Safe Input, channel A or B, respectively
SIL	Safety Integrity Level according to IEC 61508
SO	Integrated safety option

n. c. Terminal not assigned

<b>Abbreviation</b>	<b>Safety function</b>
STO	Safe Torque Off Former designation: safe standstill

## 1.5 Notes used

The following pictographs and signal words are used in this documentation to indicate dangers and important information:

### Safety instructions

Structure of safety instructions:



#### Danger!

(characterises the type and severity of danger)

#### Note

(describes the danger and gives information about how to prevent dangerous situations)

Pictograph and signal word	Meaning
<b>Danger!</b>	<b>Danger of personal injury through dangerous electrical voltage.</b> Reference to an imminent danger that may result in death or serious personal injury if the corresponding measures are not taken.
<b>Danger!</b>	<b>Danger of personal injury through a general source of danger.</b> Reference to an imminent danger that may result in death or serious personal injury if the corresponding measures are not taken.
<b>Stop!</b>	<b>Danger of property damage.</b> Reference to a possible danger that may result in property damage if the corresponding measures are not taken.

### Application notes

Pictograph and signal word	Meaning
<b>Note!</b>	Important note to ensure troublefree operation
<b>Tip!</b>	Useful tip for simple handling
<b>Reference!</b>	Reference to another documentation

### Special safety instructions and application notes for UL and UR

Pictograph and signal word	Meaning
<b>Warnings!</b>	<b>Safety or application note for the operation of a UL-approved device in UL-approved systems.</b> Possibly the drive system is not operated in compliance with UL if the corresponding measures are not taken.
<b>Warnings!</b>	<b>Safety or application note for the operation of a UR-approved device in UL-approved systems.</b> Possibly the drive system is not operated in compliance with UL if the corresponding measures are not taken.

(in accordance with Low-Voltage Directive 2006/95/EC)

**For your personal safety**

Disregarding the following safety measures can lead to severe injury to persons and damage to material assets:

- ▶ Only use the product as directed.
- ▶ Never commission the product in the event of visible damage.
- ▶ Never commission the product before assembly has been completed.
- ▶ Do not carry out any technical changes on the product.
- ▶ Only use the accessories approved for the product.
- ▶ Only use original spare parts from Lenze.
- ▶ Observe all regulations for the prevention of accidents, directives and laws applicable on site.
- ▶ Transport, installation, commissioning and maintenance work must only be carried out by qualified personnel.
  - Observe IEC 364 and CENELEC HD 384 or DIN VDE 0100 and IEC report 664 or DIN VDE 0110 and all national regulations for the prevention of accidents.
  - According to this basic safety information, qualified, skilled personnel are persons who are familiar with the assembly, installation, commissioning, and operation of the product and who have the qualifications necessary for their occupation.
- ▶ Observe all specifications in this documentation.
  - This is the condition for safe and trouble-free operation and the achievement of the specified product features.
  - The procedural notes and circuit details described in this documentation are only proposals. It's up to the user to check whether they can be transferred to the particular applications. Lenze Drives GmbH does not accept any liability for the suitability of the procedures and circuit proposals described.
- ▶ Depending on their degree of protection, some parts of the Lenze controllers (frequency inverters, servo inverters, DC speed controllers) and their accessory components can be live, moving and rotating during operation. Surfaces can be hot.
  - Non-authorized removal of the required cover, inappropriate use, incorrect installation or operation, creates the risk of severe injury to persons or damage to material assets.
  - For more information, please see the documentation.
- ▶ High amounts of energy are produced in the controller. Therefore it is required to wear personal protective equipment (body protection, headgear, eye protection, ear protection, hand guard).

### Application as directed

Controllers are components which are designed for installation in electrical systems or machines. They are not to be used as domestic appliances, but only for industrial purposes according to EN 61000-3-2.

When controllers are installed into machines, commissioning (i.e. starting of the operation as directed) is prohibited until it is proven that the machine complies with the regulations of the EC Directive 2006/42/EC (Machinery Directive); EN 60204 must be observed.

Commissioning (i.e. starting of the operation as directed) is only allowed when there is compliance with the EMC Directive (2004/108/EC).

The controllers meet the requirements of the Low-Voltage Directive 2006/95/EC. The harmonised standard EN 61800-5-1 applies to the controllers.

The technical data and supply conditions can be obtained from the nameplate and the documentation. They must be strictly observed.

**Warning:** Controllers are products which can be installed in drive systems of category C2 according to EN 61800-3. These products can cause radio interferences in residential areas. In this case, special measures can be necessary.

### Transport, storage

Please observe the notes on transport, storage, and appropriate handling.

Observe the climatic conditions according to the technical data.

### Installation

The controllers must be installed and cooled according to the instructions given in the corresponding documentation.

The ambient air must not exceed degree of pollution 2 according to EN 61800-5-1.

Ensure proper handling and avoid excessive mechanical stress. Do not bend any components and do not change any insulation distances during transport or handling. Do not touch any electronic components and contacts.

Controllers contain electrostatic sensitive devices which can easily be damaged by inappropriate handling. Do not damage or destroy any electrical components since this might endanger your health!

### Electrical connection

When working on live controllers, observe the applicable national regulations for the prevention of accidents (e.g. VBG 4).

The electrical installation must be carried out according to the appropriate regulations (e.g. cable cross-sections, fuses, PE connection). Additional information can be obtained from the documentation.

The documentation provides notes on EMC-compliant installation (shielding, earthing, filter arrangement, and laying of cables). Please also observe these notes when installing CE-labelled controllers. The manufacturer of the machine or plant is responsible for the compliance with the required limit values associated with EMC legislation.

Lenze controllers may cause a DC current in the PE conductor. If a residual current device is used as a protective means in the case of direct or indirect contact with a three-phase controller, a residual current device of type B must be used on the current supply side of the controller. If the controller has a single-phase supply, it is also permissible to use a residual current device of type A. Apart from the use of a residual current device, other protective measures can also be taken, such as isolation from the environment by double or reinforced insulation, or separation from the supply system by means of a transformer.

### Operation

If necessary, systems including controllers must be equipped with additional monitoring and protection devices according to the valid safety regulations (e.g. law on technical equipment, regulations for the prevention of accidents). The controllers can be adapted to your application. Please observe the corresponding information given in the documentation.

After the controller has been disconnected from the supply voltage, all live components and power terminals must not be touched immediately because capacitors can still be charged. Please observe the corresponding stickers on the controller.

All protection covers and doors must be shut during operation.

**Notes for UL-approved systems with integrated controllers:** UL warnings are notes that only apply to UL systems. The documentation contains special UL notes.

### Safety functions

Certain controller versions support safety functions (e.g. "Safe torque off", formerly "Safe standstill") according to the requirements of the EC Directive "Machinery" 2006/42/EC. The notes provided in the documentation on drive-based safety must be strictly observed.

### Maintenance and servicing

The controllers do not require any maintenance if the prescribed operating conditions are observed.

### Disposal

Recycle metal and plastic materials. Ensure professional disposal of assembled PCBs.

**The product-specific safety and application notes given in these instructions must be observed!**

## 2.2 General safety and application instructions for Lenze motors

(According to: Low-Voltage Directive 2006/95/EC)

### General

Low-voltage machines have hazardous live and rotating parts and possibly also hot surfaces.

Synchronous machines induce voltages at open terminals during operation.

All operations concerning transport, connections, commissioning and maintenance must be carried out by qualified, skilled personnel (EN 50110-1 (VDE 0105-100) and IEC 60364 must be observed). Inappropriate use creates the risk of severe injury to persons and damage to material assets.

Low-voltage machines may only be operated under the conditions that are indicated in the section "Application as directed".

The conditions at the place of installation must comply with the data given on the nameplate and in the documentation.

### Application as directed

Low-voltage machines are intended for commercial installations. They comply with the harmonised standards of the series EN 60034 (VDE 0530). Their use in potentially explosive atmospheres is prohibited unless they are expressly intended for such use (follow additional instructions).

Low-voltage machines are components for installation into machines as defined in the Machinery Directive 2006/42/EC. Commissioning is prohibited until the conformity of the end product with this directive has been established (follow i.a. EN 60204-1)

Low-voltage machines with IP23 protection or less are only intended for outdoor use when applying special protective features.

The integrated brakes must not be used as safety brakes. It cannot be ruled out that factors which cannot be influenced, such as oil ingress due to a defective A-side shaft seal, cause a brake torque reduction.

### Transport, storage

Damages must be reported immediately upon receipt to the forwarder; if required, commissioning must be excluded. Tighten screwed-in ring bolts before transport. They are designed for the weight of the low-voltage machines, do not apply extra loads. If necessary, use suitable and adequately dimensioned means of transport (e. g. rope guides).

Remove transport locking devices before commissioning. Reuse them for further transport. When storing low-voltage machines, ensure a dry, dust-free and low-vibration ( $v_{\text{eff}} \leq 0.2 \text{ mm/s}$ ) environment (damages while being stored).

**Installation**

Ensure an even surface, solid foot and flange mounting and exact alignment if a direct clutch is connected. Avoid resonances with the rotational frequency and double mains frequency which may be caused by the assembly. Turn rotor by hand, listen for unusual slipping noises. Check the direction of rotation when the clutch is not active (observe section "Electrical connection").

Use appropriate means to mount or remove belt pulleys and clutches (heating) and cover them with a touch guard. Avoid impermissible belt tensions.

The machines are half-key balanced. The clutch must be half-key balanced, too. The visible jutting out part of the key must be removed.

If required, provide pipe connections. Designs with shaft end at bottom must be protected with a cover which prevents the ingress of foreign particles into the fan. Free circulation of the cooling air must be ensured. The exhaust air - also the exhaust air of other machines next to the drive system - must not be taken in immediately.

**Electrical connection**

All operations must only be carried out by qualified and skilled personnel on the low-voltage machine at standstill and deenergised and provided with a safe guard to prevent an unintentional restart. This also applies to auxiliary circuits (e. g. brake, encoder, blower).

Check safe isolation from supply!

If the tolerances specified in EN 60034-1; IEC 34 (VDE 0530-1) - voltage  $\pm 5\%$ , frequency  $\pm 2\%$ , waveform, symmetry - are exceeded, more heat will be generated and the electromagnetic compatibility will be affected.

Observe the data on the nameplate, operating notes, and the connection diagram in the terminal box.

The connection must ensure a continuous and safe electrical supply (no loose wire ends); use appropriate cable terminals. The connection to the PE conductor must be safe. The plug-in connector must be bolted tightly (to stop).

The clearances between blank, live parts and to earth must not fall below 8 mm at  $U_r \leq 550$  V, 10 mm at  $U_r \leq 725$  V, 14 mm at  $U_r \leq 1000$  V.

The terminal box must be free of foreign particles, dirt and moisture. All unused cable entries and the box itself must be sealed against dust and water.



### Commissioning and operation

Before commissioning after longer storage periods, measure the insulation resistance. In case of values  $\leq 1 \text{ k}\Omega$  per volt of rated voltage, dry winding.

For trial run without output elements, lock the featherkey. Do not deactivate the protective devices, not even in a trial run.

Check the correct operation of the brake before commissioning low-voltage machines with brakes.

Integrated thermal detectors do not provide full protection for the machine. If necessary, limit the maximum current. Parameterise the controller so that the motor will be switched off with  $I > I_r$  after a few seconds of operation. especially at the risk of blocking.

Vibrational severities  $v_{\text{eff}} \leq 3.5 \text{ mm/s}$  ( $P_r \leq 15 \text{ kW}$ ) or  $4.5 \text{ mm/s}$  ( $P_r > 15 \text{ kW}$ ) are acceptable if the clutch is activated.

If deviations from normal operation occur, e.g. increased temperatures, noises, vibrations, find the cause and, if required, contact the manufacturer. In case of doubt, switch off the low-voltage machine.

If the machine is exposed to dirt, clean the air channels regularly.

Shaft sealing rings and roller bearings have a limited service life.

Regrease bearings with relubricating devices while the low-voltage machine is running. Only use the grease recommended by the manufacturer. If the grease drain holes are sealed with a plug, (IP54 drive end; IP23 drive and non-drive end), remove plug before commissioning. Seal bore holes with grease. Replace prelubricated bearings (2Z bearing) after approx. 10,000 h - 20,000 h, at the latest however after 3 - 4 years.

**The product-specific safety and application notes given in these instructions must be observed!**

## 2.3

## Residual hazards

**Protection of persons**

- ▶ Switch off mains voltage before removing the controller (Drive Unit).
- ▶ Before working on the controller, check if no voltage is applied to the power terminals because
  - depending on the device - the power terminals U, V, W, Rb1, Rb2, T1 and T2 remain live for at least 3 minutes after disconnecting the mains.
  - the power terminals L1, L2, L3; U, V, W, Rb1, Rb2, T1 and T2 remain live when the motor is stopped.

**Device protection**

- ▶ Connect/disconnect all pluggable terminals only in deenergised condition!
- ▶ Detach the controllers from the installation, e.g. from the motor or mounting wall, only in deenergised condition!





**Motor protection**

- ▶ With some settings of the controller, the connected motor can be overheated.
  - E.g. longer operation of the DC injection brake.
  - Longer operation of self-ventilated motors at low speed.
  - Wrong frequency or voltage settings in the motor parameters (especially with 120 Hz motors).

**Protection of the machine/system**

- ▶ Drives can reach dangerous overspeeds (e.g. setting of high output frequencies in connection with motors and machines unsuitable for such conditions):
  - The controllers do not offer any protection against such operating conditions. Use additional components for this purpose.

**Warning by symbols**

Icon	Description
	<b>Long discharge time:</b> All power terminals remain live for up to 3 minutes after mains disconnection!
	<b>High leakage current:</b> Carry out fixed installation and PE connection in accordance with EN 61800-5-1!
	<b>Electrostatic sensitive devices:</b> Before working on the device, the staff must ensure to be free of electrostatic charge!
	<b>Hot surface:</b> Use personal protective equipment or wait until devices have cooled down!

### 3 Product description

#### 3.1 System overview

Overview of possible components of the 8400 motec system.

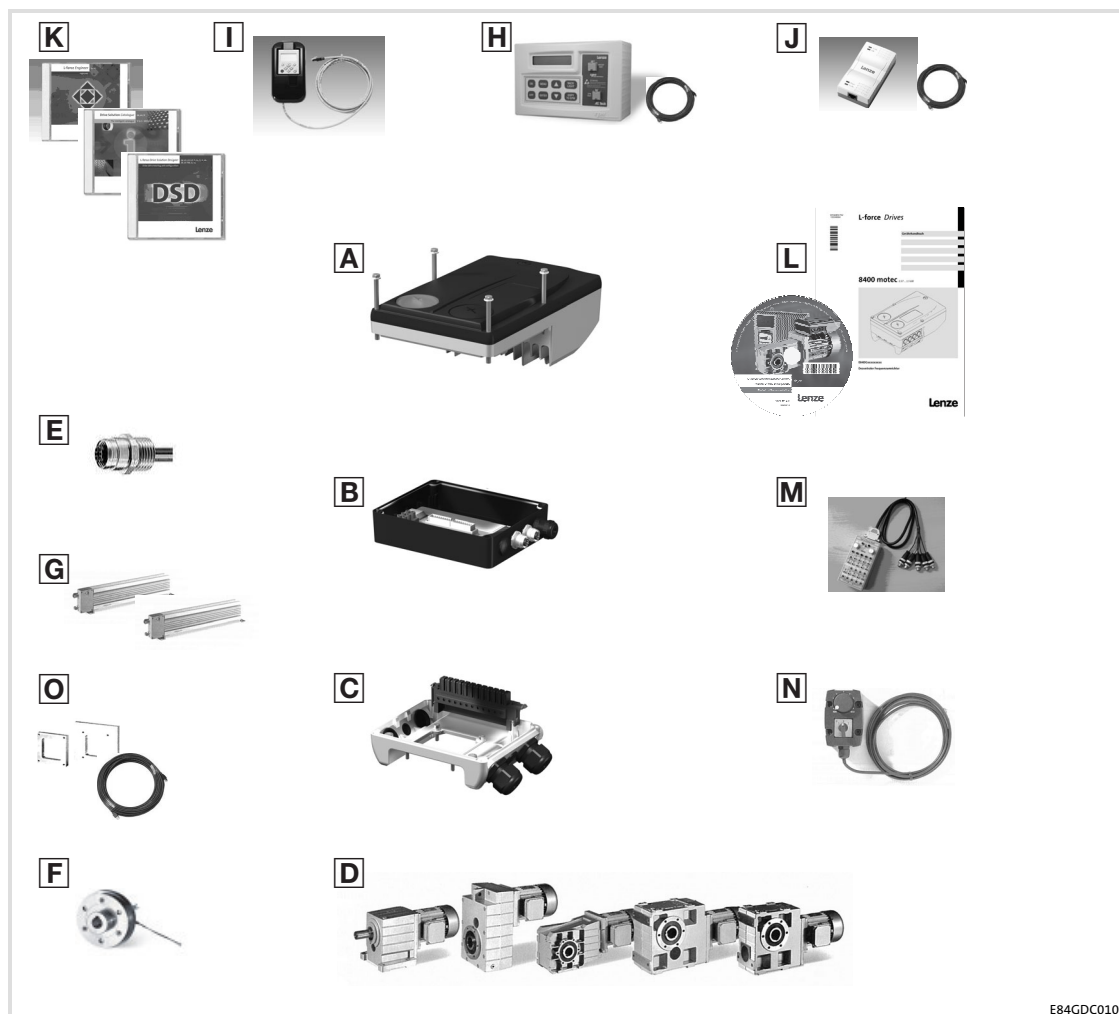

E84GDC010

- A** Drive Unit (decentralised 8400 motec frequency inverter)
- B** Communication Unit (fieldbus interfaces)
- C** Wiring Unit (motor connection adapter)
- D** Gearbox/geared motors
- E** Plugs
- F** Motor holding brakes (spring-applied brakes)
- G** Brake resistors
- H** Programming adapters
- I** Diagnosis terminals (keypads)
- J** Diagnostic adapters
- K** Software
- L** Product documentation
- M** Operating boxes
- N** Potentiometer units
- O** Mounting adapters and motor cables

## 3.2 Device features

## General features

- ▶ Compact motor inverter
- ▶ Modular design
- ▶ Part of the Inverter Drives 8400 product family
  - Identical product features
  - Identical operation
- ▶ Scalable fieldbus communication (optional)
- ▶ On site diagnostics per status LEDs
- ▶ Extensive accessories (optional)
- ▶ Pluggable memory module
- ▶ Quick commissioning via DIP switches

## Functional features

Features	Version
Power range	0.75 ... 7.5 kW
Fieldbus communication (optional)	<ul style="list-style-type: none"> <li>– CANopen</li> <li>– PROFIBUS</li> <li>– AS-i</li> <li>– EtherCAT</li> <li>– PROFINET</li> <li>– EtherNet/IP</li> </ul>
Integrated interference suppression according to EN 61800-3	✓
Flying restart circuit	✓
Integrated brake management	✓
Integrated brake chopper	✓
Integrated brake resistor	Optional
Drive-based safety	Optional: "Safe torque off (STO)"
Operating modes	<ul style="list-style-type: none"> <li>– VFCplus: V/f open loop, linear and square-law</li> <li>– SLVC: sensorless vector control (torque/speed)</li> <li>– VFC eco (energy-saving function)</li> </ul>
S-shaped ramps for smooth acceleration and deceleration	✓
Fixed frequencies	3
Overload current	200 % (3 s)
Usability on IT system	✓
Incremental encoder evaluation	Two-track, 10 kHz
Outputs	Optional: 1 digital output 1 potential-free relay contact, 2 A, NO contact
DC-injection braking	✓
Mounting	Motor mounting Optional: vertical wall mounting, cooling ribs on the top

### 3.3 Identification

Due to the modular design of the 8400 motec controllers, every unit has an own nameplate.

The nameplate shows the type designation of the respective unit. The type designation serves to exactly identify a unit.



① Type designation

#### Note

The type designation serves to identify detailed device properties with the following type code. The listing of the type code, features, and device properties does not consider any limitations of possible combinations.

### 3 Product description

Type code  
Introducing information

#### 3.4 Type code

##### 3.4.1 Introducing information

Due to the modular structure of the 8400 motec controller, every unit needs an own type key. Though, a type key is also defined for the 8400 motec controller as a set, it cannot be attached visibly to the set or single units due to practical and logistical reasons.

The following lists inform you about the type keys for:

- ▶ **Wiring Unit**  
Wiring level to the motor and mains connection
- ▶ **Communication Unit**  
Connection level for fieldbus communication and further inputs and outputs, partially optional
- ▶ **Drive unit**  
8400 motec controller
- ▶ **Accessories**  
Efficiency-improving and cost-reducing

##### 3.4.2 The type codes

###### Wiring Unit

	E84DGV			N	x	E
<b>Module part</b> Wiring Unit - 8400 motec						
<b>Version</b> N = not relevant						
<b>Size</b>						
1 = 063 / 071	(E84DGDVB3714 ... 1124)					
2 = 080 / 090 / 100	(E84DGDVB5514 ... 1524)					
3 = 080 / 090 / 100 / 112	(E84DGDVB2224 ... 3024)					
4 = 080 / 090 / 100 / 112	(E84DGDVB4024 ... 7524)					
5 = 132	(E84DGDVB5524 ... 7524)					
<b>Enclosure</b> E = IP66						

### Communication Unit

	① E84DGFC	x	x	x	x
<b>Module part</b> Communication Unit - 8400 motec					
<b>Communication (fieldbus)</b> N = NO BUS (without fieldbus) A = AS-i C = CANopen G = EtherNet/IP P = PROFIBUS R = PROFINET S = standard I/O T = EtherCAT					
<b>Connection system - communication and IO</b> N = NO BUS/standard IO: Terminal A = communication: M12, IO: Terminal 9 = communication: M12, IO: M12					
<b>Drive-based safety</b> N = none J = safety option 10 (STO - safe torque off)					
<b>Enclosure</b> P = IP65 E = IP66					

### Drive Unit

	① E84DGDV	B	xxx	4	2	x	S
<b>Module part</b> Drive Unit - 8400 motec							
<b>Version</b> B = not relevant							
<b>Power e.g.</b> 152 = $15 \times 10^2 \text{ W} = 1.5 \text{ kW}$							
<b>Voltage class</b> 4 = 400/480 V, 3/PE AC (also for IT systems)							
<b>Memory module</b> 2 = standard 8400 motec							
<b>Enclosure</b> P = IP65 E = IP66							
<b>Control element</b> S = standard (DIP switches/ potentiometer/X70)							

## 8400 motec Set

	E84DV	B	x	xxx	x	S	x	x	x	2	x	x
<b>Product range</b> Inverter Drives 8400 motec												
<b>Version</b> B = not relevant												
<b>Design</b> M = motor-mounted device W = wall-mounted device												
<b>Power e.g.</b> 152 = 15 x 10 <sup>2</sup> W = 1.5 kW												
<b>Voltage class</b> 4 = 400/480 V, 3/PE AC (also for IT systems)												
<b>Control element</b> S = standard (DIP switches/ potentiometer/X70)												
<b>Communication (fieldbus)</b> N = NO BUS (without fieldbus) A = AS-i C = CANopen G = EtherNet/IP P = PROFIBUS R = PROFINET S = standard I/O T = EtherCAT												
<b>Connection system - communication and IO</b> N = NO BUS/standard IO: Terminal A = communication: M12, IO: Terminal 9 = communication: M12, IO: M12												
<b>Drive-based safety</b> N = none J = safety option 10 (safe torque off) (incl. supplements IO)												
<b>Memory module</b> 2 = for motec												
<b>Enclosure</b> P = IP65 E = IP66												
<b>Size</b> 1 = 063 / 071 (E84DGDVB3714 ... 1124) 2 = 080 / 090 / 100 (E84DGDVB5514 ... 1524) 3 = 080 / 090 / 100 / 112 (E84DGDVB2224 ... 3024) 4 = 080 / 090 / 100 / 112 (E84DGDVB4024 ... 7524) 5 = 132 (E84DGDVB5524 ... 7524)												



### 3.5 Overview of control terminals

The control terminals of the 8400 motec controllers are available in the entire system in two versions:

- ▶ Extended or
- ▶ Standard.

The control terminals are always located in the Communication Unit.

The type of fieldbus version, power class of the inverter or motor frame size have no influence on the availability.

Connection options for Communication Unit								WU
Plugs Name	X3 Fieldbus	X61 Safety SIA/SIB	X4			Analog input AI/AU	Relay COM/NO	X1 Holding brake BD1/BD2
			Digital input/output					
Type			RFR	Dix	DO1			
E84DGFCNNNx	NO BUS (without fieldbus)	-	1 x	2 x	-	-	✓	✓
E84DGFCNNNx	Standard I/O (without fieldbus)	-	1 x	5 x	✓	✓	✓	✓
E84DGFCANxN	ASi	-	1 x	5 x	✓	-	-	✓
E84DGFCANxJ		✓				✓	✓	
E84DGFCANxN	CAN	-				-	-	
E84DGFCANxJ		✓				✓	✓	
E84DGFCANxN	EtherNet/IP	-				-	-	
E84DGFCANxJ		✓				✓	✓	
E84DGFCANxN	PROFIBUS	-				-	-	
E84DGFCANxJ		✓				✓	✓	
E84DGFCANxN	PROFINET	-				-	-	
E84DGFCANxJ		✓				✓	✓	
E84DGFCANxN	EtherCAT	-				-	-	
E84DGFCANxJ		✓				✓	✓	

- ✓ available
- not available

## 4 Technical data

General data and operating conditions

## 4 Technical data

### 4.1 General data and operating conditions

Conformity and approval			
Conformity			
CE	2006/95/EC	LowVoltage Directive	
Approval			
UR	UL 508C	Power Conversion Equipment, File No. E170350	
cUR	C22.2 No 14		

Protection of persons and equipment			
Enclosure	EN 60529	IP65 optional: IP66	in ready-for-use state: <ul style="list-style-type: none"> <li>Close unused bores for cable glands with blanking plugs!</li> <li>Close unused connectors with protection covers or blanking plugs!</li> </ul>
	NEMA 250	Protection according to <ul style="list-style-type: none"> <li>Type 4</li> </ul>	
(Earth) leakage current	EN 61800-5-1	> 3.5 mA AC, > 10 mA DC	Observe the regulations and safety instructions!
Total fault current		In TN systems the following earth-leakage circuit breakers can be used:	
Motor mounting		E84DGDVB3714 ... E84DGDVB1524	30 mA, type B
		E84DGDVB2224 ... E84DGDVB7524	300 mA, type B
Wall mounting		E84DGDVB3714 ... E84DGDVB7524	300 mA, type B
Additional equipotential bonding		M5 thread with terminal in the WU for connection of a 16mm <sup>2</sup> PE cable	
Protective insulation of control circuits	EN 61800-5-1	Safe isolation from mains by double (reinforced) insulation	
Insulation resistance	EN 61800-5-1	Site altitude	
		0 ... 2000 m	Overvoltage category III
		2000 ... 4000 m	Overvoltage category II
Short-circuit strength	EN 61800-5-1	Connection:	
		Motor	To a limited extent, the controller is inhibited, error acknowledgement required
		Motor holding brake, brake resistor	No
Earth-fault strength	EN 61800-5-1	Connection:	
		Motor (at controller enable)	To a limited extent, the controller is inhibited, error acknowledgement required
		Motor (during operation)	No
		Brake resistor, PTC	No
Protective measures against		<ul style="list-style-type: none"> <li>Short circuit on the motor side at switch-on and during operation</li> <li>Motor stalling</li> <li>Motor overtemperature                             <ul style="list-style-type: none"> <li>Input for PTC or thermal contact</li> <li>I<sup>2</sup>t monitoring</li> </ul> </li> </ul>	
Cyclic mains switching		Switchings/minute	3
		Switchings/hour	Max. 20
		Switching pause	After switching the mains 3 times in one minute, there must be a switching pause of 9 minutes.
Starting current		≤ 2 x I <sub>N</sub>	

Supply conditions			
Mains connection			
Power system			
TT, TN (with an earthed neutral)		Operation permitted without restrictions.	
IT		Implement the measure described for IT systems (remove IT screw). The machine/system manufacturer is responsible for compliance with EMC requirements for noise emission (EN 61800-3) for the machine/plant! Operation with an integrated safety system is <b>not</b> permissible.	
Motor connection			
Motors	EN 60034	Only use motors suitable for inverter operation. Insulation resistance: at least $\hat{u} \geq 1.5$ kV, at least $du/dt \geq 5$ kV/ $\mu$ s	
Length of the motor cable		< 20 m (Lenze system cable, shielded)	
Ambient conditions			
Climatic			
Storage	IEC/EN 60721-3-1	1K3 (-30 ... +60 °C)	
Transport	IEC/EN 60721-3-2	2K3 (-30 ... +75 °C)	
Operation	IEC/EN 60721-3-3	3K3 (-30 ... +55 °C) Operation at 4 kHz: > +45 °C: Reduce the rated output current by 2.5 %/°C. Operation at 8/16 kHz: > +40 °C: Reduce the rated output current by 2.5 %/°C.	
Site altitude		< 4000 m amsl Above 1000 m amsl reduce the rated output current by 5 %/ 1000 m.	
Pollution	IEC/EN 61800-5-1	Degree of pollution 2	
Mechanical			
Vibration resistance (9.81 m/s <sup>2</sup> = 1 g)			
Motor mounting	Germanischer Lloyd	General conditions: Acceleration resistant up to 2 g	
	IEC/EN 60721-3-3	3M6	
Wall mounting with E84DZMAWE1	Germanischer Lloyd	General conditions: Acceleration resistant up to 2 g	
	IEC/EN 60721-3-3	3M6	
Mounting conditions			
Mounting place			
Motor mounting		Standard	
Wall mounting		With optional wall adapter	Ensure convection cooling in the niches!
Mounting position			
Wall mounting			
E84DGDVB3714 ...		Vertical, cooling ribs at the top	Arrangement of several devices only to the sides, so that the convection cooling remains ensured!
E84DGDVB3024			
E84DGDVB4024 ...		Optional	
E84DGDVB7524			

EMC			
Noise emission (in TN and TT mains)			
Cable-guided	EN 61800-3		
Motor mounting		E84DVBM3714 ... 1524	Category C1
		E84DVBM2224 ... 3024 for switching frequency $\leq 4$ kHz	Category C1
		E84DVBM4024 ... 7524	Category C2
Wall mounting	EN 61800-3	E84DVBW3714 ... 7524 for switching frequency $\leq 4$ kHz and with Lenze system cable $\leq 20$ m	Category C2
		E84DVBW3714 ... 7524 for switching frequency $\leq 8$ kHz and with Lenze system cable $\leq 10$ m	Category C2
Radiation	EN 61800-3	E84DVBM3714 ... 1524 for switching frequency $\leq 8$ kHz	Category C1
		E84DVBM2224 ... 7524 for switching frequency $\leq 8$ kHz	Category C2
Noise immunity (according to requirements of EN 61800-3)			
Electrostatic discharge (ESD)	EN 61000-4-2	8 kV with air discharge, 4 kV with contact discharge against housing	
Radio frequency			
Conducted	EN 61000-4-6	150 kHz ... 80 MHz, 10 V/m 80 % AM (1kHz)	
Interference (housing)	EN 61000-4-3	80 MHz ... 1000 MHz, 10 V/m 80 % AM (1kHz)	
Burst			
Power terminals and interfaces	EN 61000-4-4	2 kV/5 kHz	
Signal interfaces	EN 61000-4-4	1 kV/5 kHz	
Control terminals	EN 61000-4-4	2 kV/5 kHz	
Surge			
Power terminals	EN 61000-4-5	1.2/50 $\mu$ s, 1 kV phase/phase, 2 kV phase/PE	
Control terminals	EN 61000-4-5	1.2/50 $\mu$ s, 1 kV	
Operation on public supply systems	EN 61000-3-2 EN 61000-3-12	The devices are intended for use in an industrial environment. When being used on public network, additional measures must be taken to limit the expected radio interference. The compliance with the requirements for the machine/plant is the responsibility of the manufacturer of the machine or system!	
Voltage deviations			
Voltage dips	EN 61800-3	Short mains voltage dips (comp. IEC 61000-2-1) can lead to a switch-off of the motor.	

Control		
<b>Control modes</b>		
	VFCplus: <ul style="list-style-type: none"> <li>• V/f control (linear or square-law)</li> </ul> SLVC: <ul style="list-style-type: none"> <li>• Sensorless vector control (speed)</li> </ul> VFCplus eco: <ul style="list-style-type: none"> <li>• Energy-efficient V/f control</li> </ul>	
<b>Switching frequency</b>		
	4 kHz, 8 kHz, 16 kHz,	
<b>Torque behaviour</b>		
Maximum torque	1.5 x $M_{rated}$ for 60 s 2.0 x $M_{rated}$ for 3 s	if rated motor power = rated controller power
Setting range	1 : 10	SLVC: In speed range 3 ... 50 Hz V/f: In speed range 10 ... 50 Hz
<b>Sensorless vector control (speed)</b>		
Minimum output frequency	0.5 Hz (0 ... $M_{rated}$ )	
Accuracy	±0.5 %	In the speed range 3 ... 50 Hz
Smooth running	±0.1 Hz	
<b>Output frequency</b>		
Range	-300 Hz ... +300 Hz	
Absolute resolution	0.2 Hz	
Standardised resolution	Parameter data: 0.01 %, process data: 0.006 % (= $2^{14}$ )	
<b>Digital setpoint selection</b>		
Accuracy	±0.01 %	
<b>Analog setpoint selection</b>		
Accuracy	±2 %	Relating to final value

## 4.2 Rated data

### 4.2.1 Overview

#### Input data

Basis of the data			
Mains	Voltage $U_{Lrated}$ [V]	Voltage range $U_{Lrated}$ [V]	Frequency range $f$ [Hz]
3/PE AC	400	320 - 0 % ... 440 + 0 %	45 - 0 % ... 65 + 0 %
3/PE AC	480	432 - 0 % ... 528 + 0 %	45 - 0 % ... 65 + 0 %

	Voltage [V]	Frequency [Hz]	Rated current [A]		Number of phases
			up to +45 °C ①	up to +55 °C ①	
E84DGDVB3714	400/480	50/60	1.3/1.1	1.0/0.8	3
E84DGDVB5514	400/480	50/60	1.8/1.5	1.4/1.1	3
E84DGDVB7514	400/480	50/60	2.4/2.0	1.8/1.5	3
E84DGDVB1124	400/480	50/60	3.2/2.7	2.4/2.0	3
E84DGDVB1524	400/480	50/60	3.8/3.1	2.9/2.3	3
E84DGDVB2224	400/480	50/60	5.6/4.6	4.2/3.5	3
E84DGDVB3024	400/480	50/60	7.2/5.9	5.4/4.4	3
E84DGDVB4024	400/480	50/60	9.3/7.7	7.0/5.8	3
E84DGDVB5524	400/480	50/60	12.8/10.6	9.6/8.0	3
E84DGDVB7524	400/480	50/60	16.3/13.5	12.3/10.1	3

① Ambient temperature, switching frequency 4 kHz

#### Output data

	Voltage [V]	Frequency [Hz]	Rated current [A]		Number of phases
			up to +45 °C ①	up to +55 °C ①	
E84DGDVB3714	0 ... 400/480	0 ... 300	1.3/1.1	1.0/0.8	3
E84DGDVB5514	0 ... 400/480	0 ... 300	1.8/1.5	1.4/1.1	3
E84DGDVB7514	0 ... 400/480	0 ... 300	2.4/2.0	1.8/1.5	3
E84DGDVB1124	0 ... 400/480	0 ... 300	3.2/2.7	2.4/2.0	3
E84DGDVB1524	0 ... 400/480	0 ... 300	3.9/3.2	2.9/2.4	3
E84DGDVB2224	0 ... 400/480	0 ... 300	5.6/4.7	4.2/3.5	3
E84DGDVB3024	0 ... 400/480	0 ... 300	7.3/6.0	5.4/4.5	3
E84DGDVB4024	0 ... 400/480	0 ... 300	9.5/7.9	7.1/5.9	3
E84DGDVB5524	0 ... 400/480	0 ... 300	13.0/10.8	9.8/8.1	3
E84DGDVB7524	0 ... 400/480	0 ... 300	16.5/13.7	12.4/10.3	3

① Ambient temperature, switching frequency 4 kHz



#### Note!

The maximally possible output voltage is approx. 94 % of the mains voltage.

## Power losses

Type	Power loss $P_V$ [W]	
	when operating with rated output current $I_{\text{rated}}$	when controller is inhibited
E84DGDVB3714	26	9
E84DGDVB5514	33	9
E84DGDVB7514	41	9
E84DGDVB1124	52	9
E84DGDVB1524	61	9
E84DGDVB2224	88	10
E84DGDVB3024	111	10
E84DGDVB4024	140	11
E84DGDVB5524	185	11
E84DGDVB7524	230	11



4.2.2 Operation at rated mains voltage 400 V

Basis of the data			
Mains	Voltage $U_{Lrated}$ [V]	Voltage range $U_{Lrated}$ [V]	Frequency range $f$ [Hz]
3/PE AC	400	320 - 0 % ... 440 + 0 %	45 - 0 % ... 65 + 0 %

Type	Mains current at $I_{arated}$ $I_{Lrated}$ [A]	Output power $U, V, W$ $S_{arated}$ [kVA]	Motor power 4 pol. ASM $P_{arated}$ [kW]
E84DGDVB3714	1.3	0.8	0.37
E84DGDVB5514	1.8	1.1	0.55
E84DGDVB7514	2.4	1.5	0.75
E84DGDVB1124	3.2	2.0	1.1
E84DGDVB1524	3.8	2.4	1.5
E84DGDVB2224	5.6	3.4	2.2
E84DGDVB3024	7.2	4.4	3.0
E84DGDVB4024	9.3	5.7	4.0
E84DGDVB5524	12.8	7.8	5.5
E84DGDVB7524	16.3	9.9	7.5

Type	Output currents [A] at switching frequency							
	2 kHz		4 kHz		8 kHz		16 kHz	
	$I_{arated2}$	$I_{aM2}$	$I_{arated4}$	$I_{aM4}$	$I_{arated8}$	$I_{aM8}$	$I_{arated16}$	$I_{aM16}$
E84DGDVB3714	-	-	1.3	2.6	1.3	2.6	0.9	1.6
E84DGDVB5514	-	-	1.8	3.6	1.8	3.6	1.2	2.2
E84DGDVB7514	-	-	2.4	4.8	2.4	4.8	1.6	2.9
E84DGDVB1124	-	-	3.2	6.4	3.2	6.4	2.1	3.8
E84DGDVB1524	-	-	3.9	7.8	3.9	7.8	2.6	4.7
E84DGDVB2224	-	-	5.6	11.2	5.6	11.2	3.7	6.7
E84DGDVB3024	-	-	7.3	14.6	7.3	14.6	4.9	8.8
E84DGDVB4024	-	-	9.5	19.0	9.5	19.0	6.3	11.4
E84DGDVB5524	-	-	13.0	26.0	13.0	26.0	8.7	15.6
E84DGDVB7524	-	-	16.5	33.0	16.5	33.0	11.0	19.8

$I_{aNx}$   
 $I_{aMx}$

Rated value of continuous output current  
Maximum output current (overload current)  

- Periodic load change of 3 s with  $I_{aMx}$  and recovery time of 12 s according to the tables under chapter 4.4
- Can be obtained in the setting "x kHz fixed/..." in C00018

Switching frequency

If the maximum heatsink temperature is reached, the switching frequency is reduced to 4 kHz.  
In the setting "x kHz var./..." in C00018 the switching frequency is reduced depending on the output current.  
Depending on the switching frequency and e.g. the ambient temperature, it may be required to reduce the output current (chapter 4.1, operating conditions).

## Fuses and cable cross-sections

## ► Point-to-point connection - direct wiring of the mains voltage - typical fusing

Operation								
Type	Installation according to EN 60204-1 <sup>1)</sup>					Installation according to UL <sup>2)</sup>		FI <sup>3)</sup> [mA]
	①	②	L1, L2, L3 - laying system			③	L1, L2, L3	
			B2	C	F			
	[A]	[A]	[mm <sup>2</sup> ]	[mm <sup>2</sup> ]	[mm <sup>2</sup> ]	[A]	[AWG]	[mA]
E84DGDVB3714	C 16	16	2.5	-	-	15	12	≥ 30
E84DGDVB5514	C 16	16	2.5	-	-	15	12	≥ 30
E84DGDVB7514	C 16	16	2.5	-	-	15	12	≥ 30
E84DGDVB1124	C 16	16	2.5	-	-	15	12	≥ 30
E84DGDVB1524	C 16	16	2.5	-	-	15	12	≥ 30
E84DGDVB2224	C 16	16	2.5	-	-	15	12	≥ 300
E84DGDVB3024	C 16	16	2.5	-	-	15	12	≥ 300
E84DGDVB4024	C 20	20	4.0	-	-	20	12	≥ 300
E84DGDVB5524	C 20	20	4.0	-	-	20	12	≥ 300
E84DGDVB7524	C 20	20	4.0	-	-	20	12	≥ 300

## ► Multiple connection - loop-through connection of the mains voltage - maximum fusing

Operation								
Type	Installation according to EN 60204-1 <sup>1)</sup>					Installation according to UL <sup>2)</sup>		FI <sup>3)</sup> [mA]
	①	②	L1, L2, L3 - laying system			③	L1, L2, L3	
			B2	C	F			
	[A]	[A]	[mm <sup>2</sup> ]	[mm <sup>2</sup> ]	[mm <sup>2</sup> ]	[A]	[AWG]	[mA]
E84DGDVB3714	C 32	32	6.0	-	-	15	12	≥ 30
E84DGDVB5514	C 32	32	6.0	-	-	15	12	≥ 30
E84DGDVB7514	C 32	32	6.0	-	-	15	12	≥ 30
E84DGDVB1124	C 32	32	6.0	-	-	15	12	≥ 30
E84DGDVB1524	C 32	32	6.0	-	-	15	12	≥ 30
E84DGDVB2224	C 32	32	6.0	-	-	25	10	≥ 300
E84DGDVB3024	C 32	32	6.0	-	-	25	10	≥ 300
E84DGDVB4024	C 50	50	16.0	-	-	50	6	≥ 300
E84DGDVB5524	C 50	50	16.0	-	-	50	6	≥ 300
E84DGDVB7524	C 50	50	16.0	-	-	50	6	≥ 300

1) These values are recommendations only. Other dimensioning values/laying systems are possible (e.g. according to VDE 0298-4). The cable cross-sections apply under the following conditions: Use of PVC-insulated copper cables, conductor temperature < 70 °C, ambient temperature < 45°C, no bundling of cables or cores, three loaded cores.

2) Only use UL-approved cables, fuses and fuse holders.

UL fuse: voltage ≥ 500 V, tripping characteristic e.g. "CC". The cable cross-sections apply under the following conditions: conductor temperature < 75 °C, ambient temperature < 45°C.

3) Universal-current sensitive earth-leakage circuit breaker, short-time delayed

① Circuit breaker

② Fuse of gG/gL utilisation category or semiconductor fuses of gRL utilisation category

③ Fuse

Observe national and regional regulations

### 4.2.3 Operation at increased rated power at 400 V mains voltage

In continuous operation, the controllers can be actuated with a more powerful motor. The overload capacity is limited to 120 %. Typical applications are pumps with a quadratic load characteristic, or fans.



**Note!**

Operation with an increased rated power is only permitted ...

- ▶ with the rated data specified for the controller.
- ▶ within the mains voltage range specified.
- ▶ with the switching frequency 4 kHz.
- ▶ at a max. ambient temperature of 40 °C
- ▶ with the fuses and cable cross-sections specified for this operation.
- ▶ after parameterisation according to the specifications (cf. EDS84DM... software manual)

Basis of the data			
Mains	Voltage $U_{Lrated}$ [V]	Voltage range $U_{Lrated}$ [V]	Frequency range $f$ [Hz]
3/PE AC	400	320 - 0 % ... 440 + 0 %	45 - 0 % ... 65 + 0 %

Type	Mains current at $I_{Lrated}$ $I_{Lrated}$ [A]	Output power U, V, W $S_{rated}$ [kVA]	Motor power 4 pol. ASM $P_{rated}$ [kW]
E84DGDVB3714	1.6	1.0	0.55
E84DGDVB5514	2.2	1.3	0.75
E84DGDVB7514	2.9	1.8	1.1
E84DGDVB1124	3.8	2.4	1.5
E84DGDVB1524 <sup>1)</sup>	4.5	3.0	1.8
E84DGDVB2224	6.7	4.1	2.2
E84DGDVB3024 <sup>1)</sup>	8.6	5.3	4.0
E84DGDVB4024	11.1	6.8	5.5
E84DGDVB5524	15.3	9.4	7.5
E84DGDVB7524	19.5	11.9	9.2

1) Operation with an increased rated power only for motor mounting.

## Switching frequency-dependent output currents

Type	Output currents [A] at switching frequency							
	2 kHz		4 kHz		8 kHz		16 kHz	
	$I_{arated2}$	$I_{aM2}$	$I_{arated4}$	$I_{aM4}$	$I_{arated8}$	$I_{aM8}$	$I_{arated16}$	$I_{aM16}$
E84DGDVB3714	-	-	1.6	2.6	-	-	-	-
E84DGDVB5514	-	-	2.2	3.6	-	-	-	-
E84DGDVB7514	-	-	2.9	4.8	-	-	-	-
E84DGDVB1124	-	-	3.8	6.4	-	-	-	-
E84DGDVB1524 <sup>1)</sup>	-	-	4.7	7.8	-	-	-	-
E84DGDVB2224	-	-	6.7	11.2	-	-	-	-
E84DGDVB3024 <sup>1)</sup>	-	-	8.7	14.6	-	-	-	-
E84DGDVB4024	-	-	11.4	19.0	-	-	-	-
E84DGDVB5524	-	-	15.6	26.0	-	-	-	-
E84DGDVB7524	-	-	19.8	33.0	-	-	-	-

$I_{aNx}$   
 $I_{aMx}$

Rated value of continuous output current

Maximum output current (overload current)

- Periodic load change of 3 s with  $I_{aMx}$  and recovery time of 12 s according to the tables under chapter  4.4

1) Operation with an increased rated power only for motor mounting.

## Fuses and cable cross-sections

The data/recommendations for operation on a rated mains voltage 400 V can be applied.

 34)

4.2.4 Operation with rated mains voltage 480 V

Basis of the data			
Mains	Voltage $U_{Lrated}$ [V]	Voltage range $U_{Lrated}$ [V]	Frequency range $f$ [Hz]
3/PE AC	480	432 - 0 % ... 528 + 0 %	45 - 0 % ... 65 + 0 %

Type	Mains current at $I_{arated}$ $I_{Lrated}$ [A]	Output power $U, V, W$ $S_{arated}$ [kVA]	Motor power 4 pol. ASM $P_{arated}$ [kW]
E84DGDVB3714	1.1	0.8	0.37
E84DGDVB5514	1.5	1.1	0.55
E84DGDVB7514	2.0	1.5	0.75
E84DGDVB1124	2.7	2.1	1.1
E84DGDVB1524	3.1	2.4	1.5
E84DGDVB2224	4.6	3.5	2.2
E84DGDVB3024	5.9	4.5	3.0
E84DGDVB4024	7.7	5.7	4.0
E84DGDVB5524	10.6	7.9	5.5
E84DGDVB7524	13.5	10.0	7.5

Type	Output currents [A] at switching frequency							
	2 kHz		4 kHz		8 kHz		16 kHz	
	$I_{arated2}$	$I_{aM2}$	$I_{arated4}$	$I_{aM4}$	$I_{arated8}$	$I_{aM8}$	$I_{arated16}$	$I_{aM16}$
E84DGDVB3714	-	-	1.1	2.2	1.1	2.2	0.7	1.3
E84DGDVB5514	-	-	1.5	3.0	1.5	3.0	1.0	1.8
E84DGDVB7514	-	-	2.0	4.0	2.0	4.0	1.3	2.4
E84DGDVB1124	-	-	2.7	5.4	2.7	5.4	1.8	3.2
E84DGDVB1524	-	-	3.2	6.4	3.2	6.4	2.1	3.8
E84DGDVB2224	-	-	4.7	9.4	4.7	9.4	3.1	5.6
E84DGDVB3024	-	-	6.0	12.0	6.0	12.0	4.0	7.2
E84DGDVB4024	-	-	7.9	15.8	7.9	15.8	5.3	9.5
E84DGDVB5524	-	-	10.8	21.6	10.8	21.6	7.2	13.0
E84DGDVB7524	-	-	13.7	27.4	13.7	27.4	9.1	16.4

$I_{aNx}$   
 $I_{aMx}$

Rated value of continuous output current  
Maximum output current (overload current)  

- Periodic load change of 3 s with  $I_{aMx}$  and recovery time of 12 s according to the tables under chapter 4.4
- Can be obtained in the setting "x kHz fixed/..." in C00018

Switching frequency

If the maximum heatsink temperature is reached, the switching frequency is reduced to 4 kHz.  
In the setting "x kHz var./..." in C00018 the switching frequency is reduced depending on the output current.  
Depending on the switching frequency and e.g. the ambient temperature, it may be required to reduce the output current (chapter 4.1, operating conditions).

## Fuses and cable cross-sections

## ► Point-to-point connection - direct wiring of the mains voltage - typical fusing

Operation								
Type	Installation according to EN 60204-1 <sup>1)</sup>					Installation according to UL <sup>2)</sup>		FI <sup>3)</sup> [mA]
	① [A]	② [A]	L1, L2, L3 - laying system			③ [A]	L1, L2, L3 [AWG]	
			B2 [mm <sup>2</sup> ]	C [mm <sup>2</sup> ]	F [mm <sup>2</sup> ]			
E84DGDVB3714	C 16	16	2.5	-	-	15	12	≥ 30
E84DGDVB5514	C 16	16	2.5	-	-	15	12	≥ 30
E84DGDVB7514	C 16	16	2.5	-	-	15	12	≥ 30
E84DGDVB1124	C 16	16	2.5	-	-	15	12	≥ 30
E84DGDVB1524	C 16	16	2.5	-	-	15	12	≥ 30
E84DGDVB2224	C 16	16	2.5	-	-	15	12	≥ 300
E84DGDVB3024	C 16	16	2.5	-	-	15	12	≥ 300
E84DGDVB4024	C 20	20	4.0	-	-	20	12	≥ 300
E84DGDVB5524	C 20	20	4.0	-	-	20	12	≥ 300
E84DGDVB7524	C 20	20	4.0	-	-	20	12	≥ 300

## ► Multiple connection - loop-through connection of the mains voltage - maximum fusing

Operation								
Type	Installation according to EN 60204-1 <sup>1)</sup>					Installation according to UL <sup>2)</sup>		FI <sup>3)</sup> [mA]
	① [A]	② [A]	L1, L2, L3 - laying system			③ [A]	L1, L2, L3 [AWG]	
			B2 [mm <sup>2</sup> ]	C [mm <sup>2</sup> ]	F [mm <sup>2</sup> ]			
E84DGDVB3714	C 32	32	6.0	-	-	15	12	≥ 30
E84DGDVB5514	C 32	32	6.0	-	-	15	12	≥ 30
E84DGDVB7514	C 32	32	6.0	-	-	15	12	≥ 30
E84DGDVB1124	C 32	32	6.0	-	-	15	12	≥ 30
E84DGDVB1524	C 32	32	6.0	-	-	15	12	≥ 30
E84DGDVB2224	C 32	32	6.0	-	-	25	10	≥ 300
E84DGDVB3024	C 32	32	6.0	-	-	25	10	≥ 300
E84DGDVB4024	C 50	50	16.0	-	-	50	6	≥ 300
E84DGDVB5524	C 50	50	16.0	-	-	50	6	≥ 300
E84DGDVB7524	C 50	50	16.0	-	-	50	6	≥ 300

1) These values are recommendations only. Other dimensioning values/laying systems are possible (e.g. according to VDE 0298-4). The cable cross-sections apply under the following conditions: Use of PVC-insulated copper cables, conductor temperature < 70 °C, ambient temperature < 45°C, no bundling of cables or cores, three loaded cores.

2) Only use UL-approved cables, fuses and fuse holders.

UL fuse: voltage ≥ 500 V, tripping characteristic e.g. "CC". The cable cross-sections apply under the following conditions: conductor temperature < 75 °C, ambient temperature < 45°C.

3) Universal-current sensitive earth-leakage circuit breaker, short-time delayed

① Circuit breaker

② Fuse of gG/gL utilisation category or semiconductor fuses of gRL utilisation category

③ Fuse

Observe national and regional regulations

### 4.3 Switching frequency reduction

Under certain operating conditions, the maximum output current is limited for all devices:

- ▶ When the maximum heatsink temperature is exceeded, the controller switches from 16 kHz to 8 kHz and from 8 kHz to 4 kHz, irrespective of the switching frequency mode. This function can be deactivated via C00144.

If the heatsink temperature increases above 105 °C, the controller is inhibited and the error message "OH1: Heatsink overtemperature" is output.

The error response is also triggered when the switching frequency reduction is deactivated.

**4.4 Overcurrent operation**

If the device utilisation  $I_{xt}$  exceeds the threshold set (C00064/1, Lenze setting = 100 %), the monitoring function triggers an error response and sets the controller to the "Fault" device status. To exit the device status, the error must be reset ("acknowledged") explicitly.

The curves of typical load functions and the simulation of the "Ixt" function are shown in the following illustration:

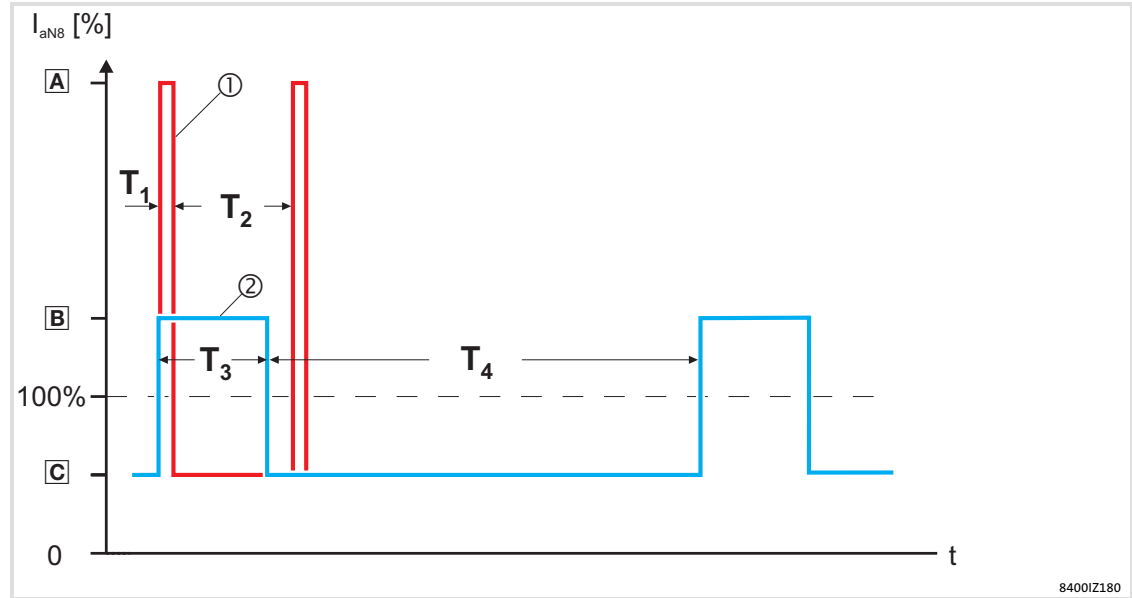

Fig. 4-1 Overcurrent capacity at 45° C

- ① Pulse load (15 s cycle)
- Ⓐ Peak current
- Ⓒ Unloading current
- T<sub>1</sub> Peak current period
- T<sub>2</sub> Unloading current period

Calculation equation:

$$\frac{A \cdot T_1 + C \cdot T_2}{T_1 + T_2} \leq 100\%$$

- ② Permanent load (180 s cycle)
- Ⓑ Peak current
- Ⓒ Unloading current
- T<sub>3</sub> Peak current period
- T<sub>4</sub> Unloading current period
- I<sub>aNx</sub> Rated value of continuous output current

Calculation equation:

$$\frac{B \cdot T_3 + C \cdot T_4}{T_3 + T_4} \leq 100\%$$



Type	$I_{amax}/I_{aN8}$ [%] in 15-s cycle ①							
	f = 2 kHz		f = 4 kHz		f = 8 kHz		f = 16 kHz	
	A	B	A	B	A	B	A	B
E84DGDVB3714								
E84DGDVB5514								
E84DGDVB7514								
E84DGDVB1124								
E84DGDVB1524			200	75	200	75	120	50
E84DGDVB2224	-	-						
E84DGDVB3024								
E84DGDVB4024								
E84DGDVB5524								
E84DGDVB7524								

Type	$I_{amax}/I_{aN8}$ [%] in 180-s cycle ②							
	f = 2 kHz		f = 4 kHz		f = 8 kHz		f = 16 kHz	
	C	D	C	D	C	D	C	D
E84DGDVB3714								
E84DGDVB5514								
E84DGDVB7514								
E84DGDVB1124								
E84DGDVB1524			150	75	150	75	100	50
E84DGDVB2224	-	-						
E84DGDVB3024								
E84DGDVB4024								
E84DGDVB5524								
E84DGDVB7524								



**Tip!**

For calculations of application-specific cycles please contact your Lenze contact person.

## 4.5 Terminal description

## 4.5.1 Overview

## 0.37 ... 3 kW

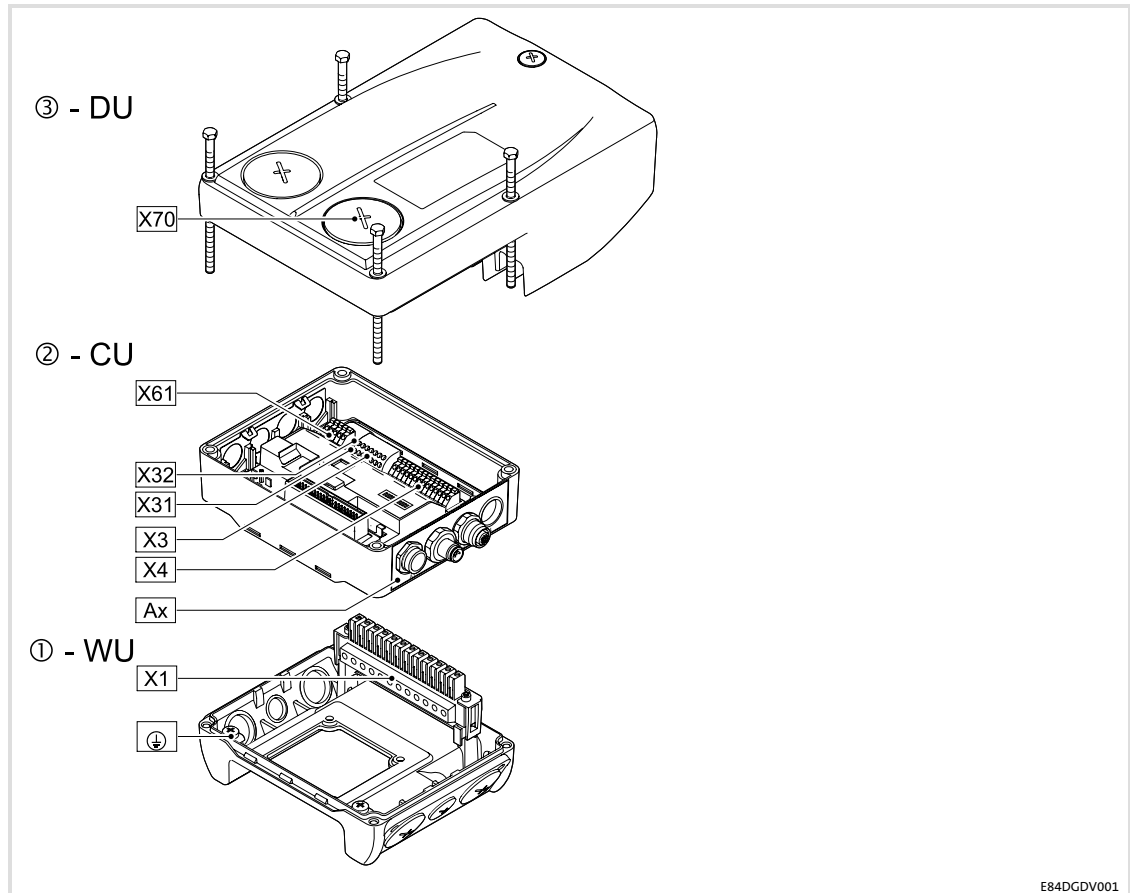

E84DGDV001

**WU - Wiring Unit**

X1/L1, L2, L3	Mains
X1/U, V, W	Motor
X1/Rb1, Rb2	Brake resistor
X1/BD1, BD2	Motor holding brake
X1/T1, T2	Motor temperature monitoring
⊕	Protective earth

**CU - Communication Unit**

The connection opportunities depend on the communication module option.

X4/COM, NO	Switching contact, potential-free
X4/Ax, GND	Analog input
X4/RFR, Dix, DO1	Digital inputs and outputs
X4/240,GND	24-V supply voltage for external sensors
X3/X31/X32	Fieldbus
X61/...	Safety
Ax	Position of LED display, connector or cable gland

**DU - Drive Unit**

X70	Diagnostics
-----	-------------

4 ... 7.5 kW

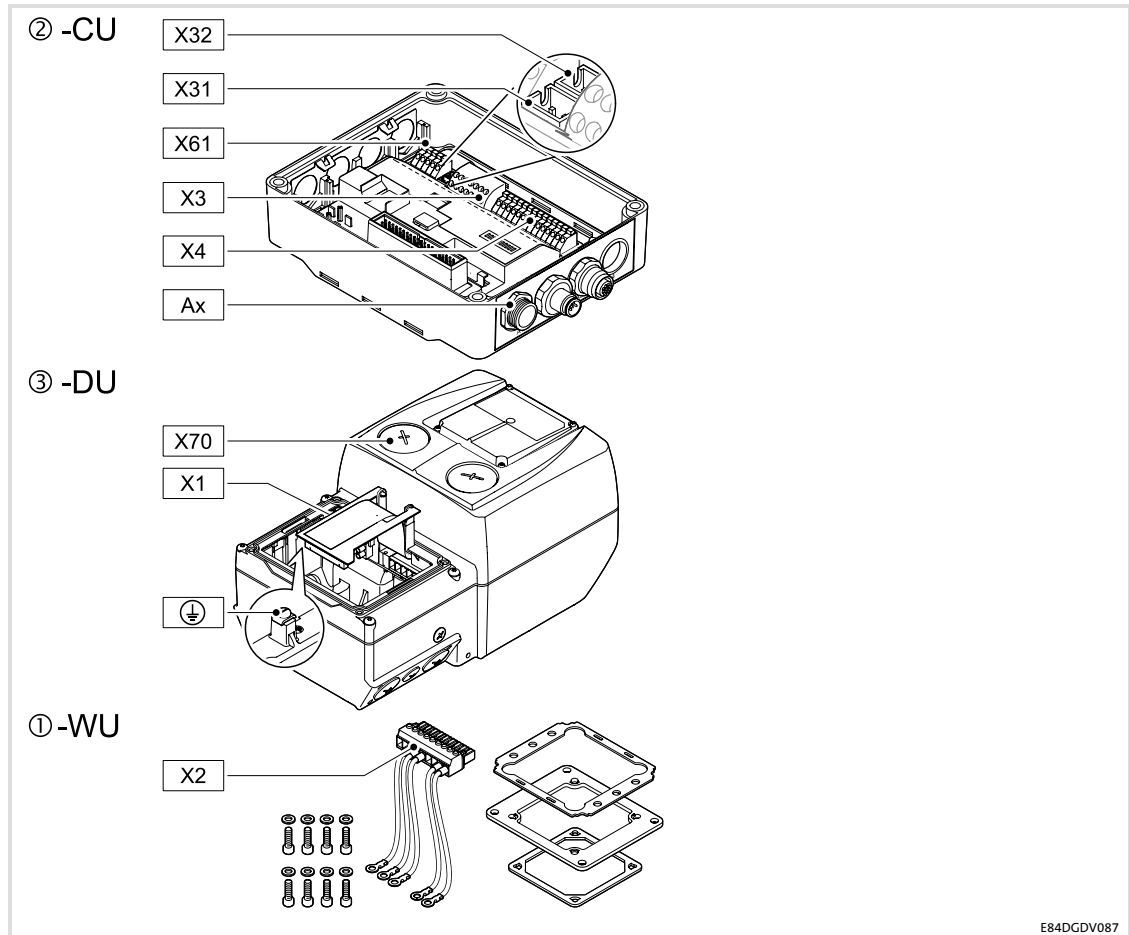

**WU - Wiring Unit**

X2/U, V, W	Motor
X2/Rb1, Rb2	Brake resistor
X2/BD1, BD2	Motor holding brake
X2/T1, T2	Motor temperature monitoring

**CU - Communication Unit**

The connection opportunities depend on the communication module option.

X4/COM, NO	Switching contact, potential-free
X4/Ax, GND	Analog input
X4/RFR, DIx, DO1	Digital inputs and outputs
X4/240,GND	24-V supply voltage for external sensors
X3/X31/X32	Fieldbus
X61/...	Safety
Ax	Position of LED display, connector or cable gland

**DU - Drive Unit**

X1/L1, L2, L3	Mains
X70	Diagnostics
⊕	Protective earth

## 4.6

## Power terminals

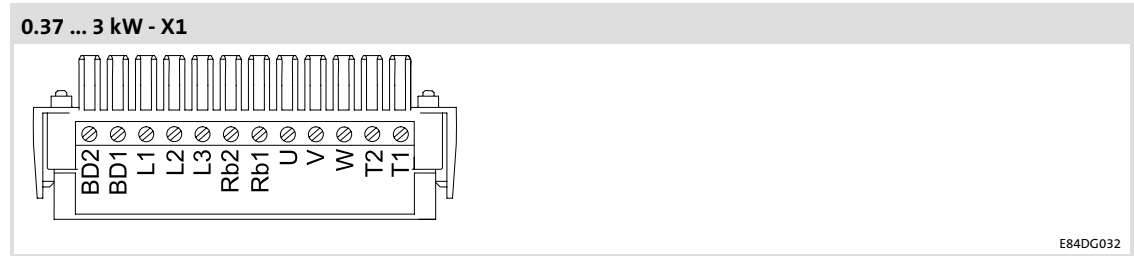

Terminal data						
		Conductor cross-section		Tightening torque		
		[mm <sup>2</sup> ]	[AWG]	[Nm]	[lb-in]	
X1	E84DGDVB3714	1 ... 4	18 ... 10	0.5	4.4	3.5 x 0.6
	...	2 x 0.5 ... 2 x 2.5				
	E84DGDVB1524	1) <sup>1)</sup>				
X1	E84DGDVB2224	1 ... 6	18 ... 8	0.8	7.0	3.5 x 0.6
	...	2 x 0.5 ... 2 x 2.5				
	E84DGDVB3024	1) <sup>1)</sup>				

1) For looping-through connections (daisy chain) => two conductors with TWIN wire end ferrule

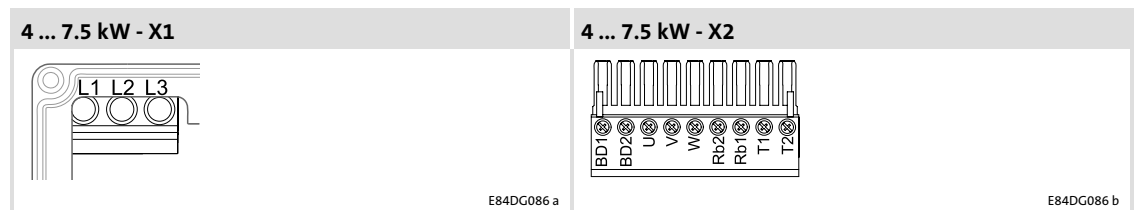

Terminal data						
		Conductor cross-section		Tightening torque		
		[mm <sup>2</sup> ]	[AWG]	[Nm]	[lb-in]	
X1		1 ... 16	18 ... 6	1.4	12	PZ 2 5.5 x 1.0
		2 x 1 ... 2 x 6 <sup>1)</sup>				
X2		1 ... 6	18 ... 8	0.8	7	PH 1 3.5 x 0.6

1) For looping-through connections (daisy chain) => two conductors with TWIN wire end ferrule

#### 4.6.1 Mains connection

Pin / name	Features	Rated value
L1, L2, L3	Mains phases	according to rated data
assigned X1:		
⊕	Earthing, 2 x in the Wu	-

#### 4.6.2 Motor connection

Pin / name	Features	Rated value
U, V, W	Motor phases	according to rated data
assigned X1:		
⊕	Earthing, 2 x in the Wu	-

#### 4.6.3 Motor temperature monitoring

Pin / name	Features	Rated value
T1, T2	Motor temperature monitoring	according to rated data

#### 4.6.4 Motor holding brake connection

Pin / name	Feature	Rated value
BD1 (+)	Connection of a motor holding brake	
BD2 (-)	Output voltage (depending on mains voltage)	AC 400 V
		AC 480 V
	Max. output current	0.3 A
	Max. output power	55 VA
	Time-dependent behaviour	See software manual, chapter "Holding brake control/parameter setting"
	Short-circuit strength	No
	Reset and switch-on behaviour	Outputs are switched off
	Operating frequency	Max. 30/min

#### 4.6.5 Connection of brake resistor

Pin / name	Features	Rated value
Rb1, Rb2	Brake resistor	according to rated data

## 4 Technical data

### Control terminals

#### 4.7 Control terminals

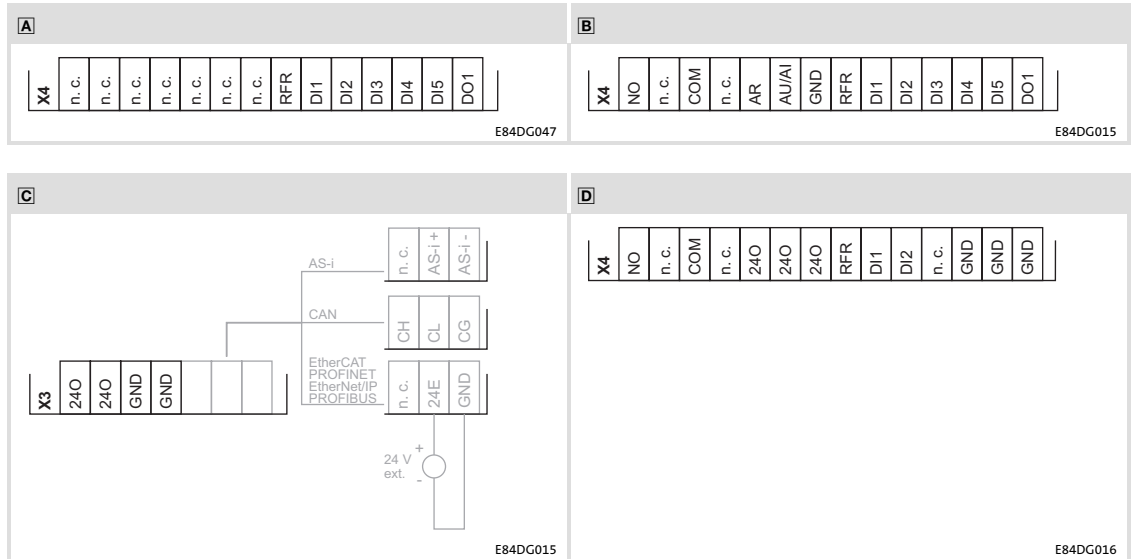

- A** Assignment X4 with CANopen, PROFIBUS, AS interface, PROFINET, EtherNet/IP, EtherCAT **without** safety (standard)
- B** Assignment X4 with CANopen, PROFIBUS, AS interface, PROFINET, EtherNet/IP, EtherCAT **with** safety (extended)
- B** Assignment X4 with standard I/O
- C** Assignment X3 with 24V/GND, additional assignment with CANopen, AS interface PROFIBUS, PROFINET, EtherNet/IP and EtherCAT
- D** Assignment X4 with NO BUS

Connection options for Communication Unit								WU
Plugs Name	X3 Fieldbus	X61 Safety	X4			Analog input	Relay	X1 Holding brake
			Digital input/output					
Type		SIA/SIB	RFR	Dix	DO1			
E84DGFCNNNx	NO BUS (without fieldbus)	-	1 x	2 x	-	-	✓	✓
E84DGFCNNNx	Standard I/O (without fieldbus)	-	1 x	5 x	✓	✓	✓	✓
E84DGFCANxN	ASi	-	1 x	5 x	✓	-	-	✓
E84DGFCANxJ		✓				✓	✓	
E84DGFCANxN	CAN	-				-	-	
E84DGFCANxJ		✓				✓	✓	
E84DGFCANxN	EtherNet/IP	-				-	-	
E84DGFCANxJ		✓				✓	✓	
E84DGFCANxN	PROFIBUS	-				-	-	
E84DGFCANxJ		✓				✓	✓	
E84DGFCANxN	PROFINET	-				-	-	
E84DGFCANxJ		✓				✓	✓	
E84DGFCANxN	EtherCAT	-				-	-	
E84DGFCANxJ		✓				✓	✓	

✓ available  
- not available

## 4.7.1



## Digital inputs

X4		
Pin / name	Features	Rated value
RFR	Controller enable	according to IEC 61131-2, type 1 or DI1/DI2: Two-track frequency input for HTL encoder 0 ... 10 kHz (parameterisable)
DI1	Digital inputs	
DI2		
DI3		
DI4		
DI5	DI3 ... DI5 not available for NO BUS	

X3		
Pin / name	Features	Rated value
240	24-V supply of external sensors or potential-free contacts	according to IEC 61131-2
GND		

In the E84DGFCx9xx version, max. four digital inputs are assigned to the M12 plugs. The plugs are mounted to the connection positions Ax, depending on the fieldbus.



## CANopen

A1	DI - E84DGFC9xx	A4	DI - E84DGFC9xx
 M12 female socket A-Coding	1 240	 M12 female socket A-Coding	1 240
	2 DI2		2 DI4
	3 GND		3 GND
	4 DI1		4 DI3
	5 n. c.		5 n. c.

## PROFIBUS

A4	DI - E84DGFC9xx
 M12 female socket A-Coding	1 240
	2 DI2
	3 GND
	4 DI1
	5 n. c.

## AS-i

A3	DI - E84DGFA9xx	A4	DI - E84DGFA9xx
 M12 female socket A-Coding	1 240	 M12 female socket A-Coding	1 240
	2 DI2		2 DI4
	3 GND		3 GND
	4 DI1		4 DI3
	5 n. c.		5 n. c.

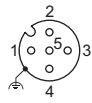

### PROFINET

A4	DI - E84DGFCR9xx
 <p>M12 female socket A-Coding</p>	1 240
	2 DI2
	3 GND
	4 DI1
	5 n. c.

### EtherCAT

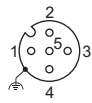
A4	DI - E84DGFACT9xx
 <p>M12 female socket A-Coding</p>	1 240
	2 DI2
	3 GND
	4 DI1
	5 n. c.

### EtherNet/IP

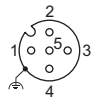
A4	DI - E84DGFCG9xx
 <p>M12 female socket A-Coding</p>	1 240
	2 DI2
	3 GND
	4 DI1
	5 n. c.

## 4 Technical data

### Control terminals

### Digital output

#### 4.7.2 Digital output

X4		
Pin / name	Features	Rated value
DO1	Digital output	24 V DC 50 mA

#### 4.7.3 Analog input

The analog input is only available with the modules

- ▶ Communication in the "Advanced" version or
- ▶ Standard I/O.

X4		
Pin / Name	Feature	Rated value
AU GND	Voltage input	0 ... 10 V
	Input resistance	> 80 kΩ
	Sampling frequency	80 Hz (12 ms)
	Accuracy	± 0.1 V
	Electric strength of external voltage	-7 ... +30 V
	A/D converter	10 bit resolution
AI GND	Current input, parameterisable	0.6 ... +20 mA (I < 0.6mA $\triangle$ "0") 4 ... +20 mA, fail-safe
	Input resistance	250 Ω
	Input current in case of open circuit	Display "0" (I < 0.6 mA)
	Sampling frequency	80 Hz (12 ms)
	Accuracy	± 0.2 mA
	Electric strength of external voltage	-7 ... +7 V
	A/D converter	10 bit resolution

#### 4.7.4 Connection of relay output

X4			
Pin / name	Features	Rated value	
COM NO	Switching contact, NO contact, potential-free	24 V DC, 2 A	not inductive
		250 V AC, 2 A	

#### **4.7.5 Communication connection**

8400 motec enables communication via the fieldbuses

- ▶ CANopen,
- ▶ PROFIBUS,
- ▶ AS interface,
- ▶ EtherNet/IP,
- ▶ PROFINET and
- ▶ EtherCat.

The connections of the fieldbuses are always assigned to M12 plugs. The plugs are mounted to the connection positions Ax, depending on the fieldbus.

With PROFIBUS, AS interface, PROFINET and EtherCat, the LED display at connection position A1 indicates the bus status.

Detailed information can be found in the corresponding communication manual.

## 4 Technical data

### Dimensions

#### Standard motor mounting

### 4.8 Dimensions

#### 4.8.1 Standard motor mounting

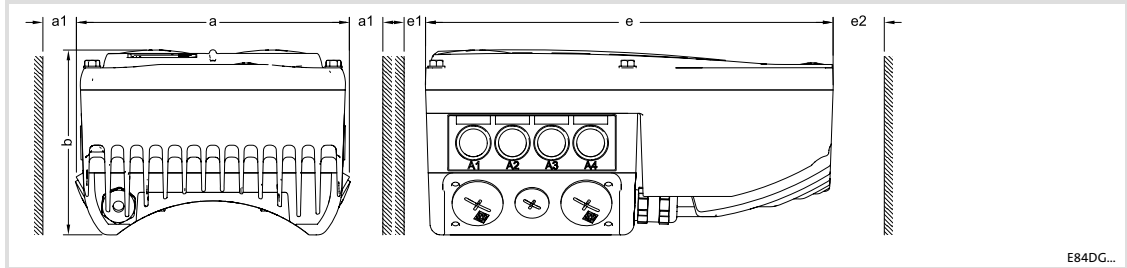

Dimensions - standard motor mounting [mm]

Type	a	b	e	a1	e1	e2	m [kg] <sup>2)</sup>
E84DGDVB371T	161	109	241	75 (20 <sup>1)</sup> )	50	100	2.6
E84DGDVB551T							
E84DGDVB751T							
E84DGDVB112T							
E84DGDVB152T	176	135	261	75 (20 <sup>1)</sup> )	50	100	3.5
E84DGDVB222T							
E84DGDVB302T							
E84DGDVB402T	195	176	325	70 (15 <sup>1)</sup> )	50	100	5.3
E84DGDVB552T							
E84DGDVB752T							

<sup>1)</sup> Reduction possible if no free space for plugs or cables/cable glands is required.

<sup>2)</sup> For the NO BUS version, without cable glands

4.8.2 Wall mounting

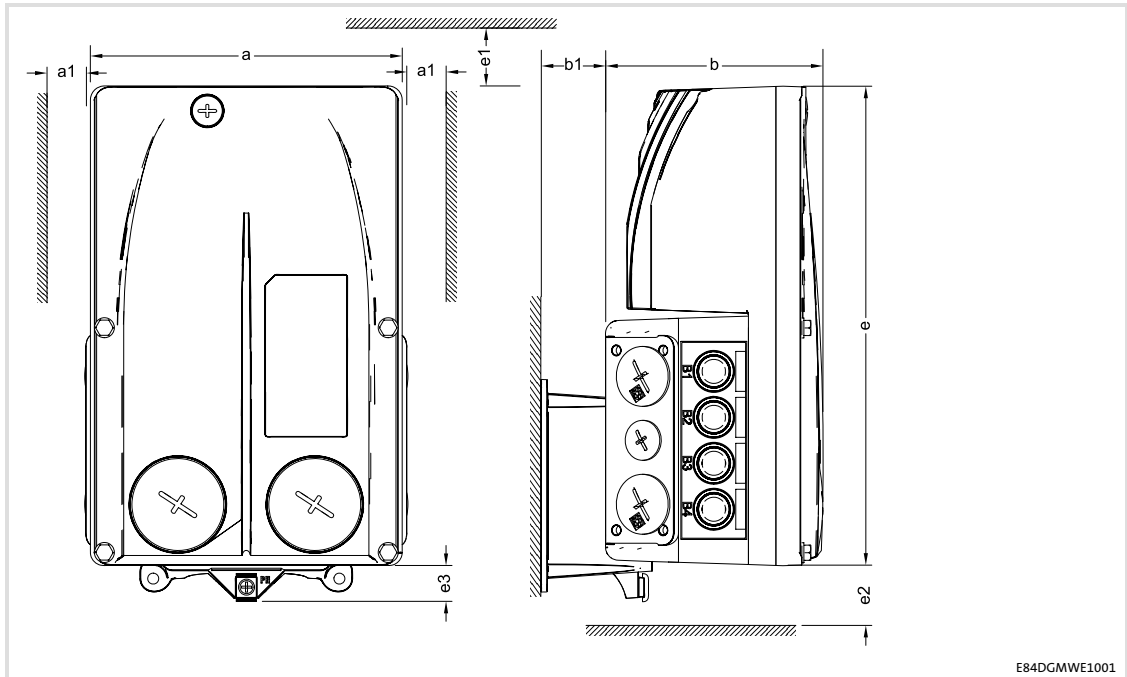

E84DGMWE1001

Dimensions - wall mounting [mm]

Type	a	b	e	b1	a1	e1	e2	e3	m [kg]
E84DGDVB371T	161	109	241	34	75 (20 <sup>1)</sup> )	50	50	16 <sup>2)</sup> 10 <sup>3)</sup>	2.8
E84DGDVB551T									
E84DGDVB751T									
E84DGDVB112T									
E84DGDVB152T	176	135	261	38	75 (20 <sup>1)</sup> )	50	50	10 <sup>3)</sup>	3.7
E84DGDVB222T									
E84DGDVB302T									

- 1) Reduction possible if no free space for plugs or cables/cable glands is required. Arrangement of several devices only to the sides, so that the convection cooling remains ensured.
- 2) With E84DGVN1E or E84DVBWxxxxxxxxx1
- 3) With E84DGVN2E or E84DVBWxxxxxxxxx2

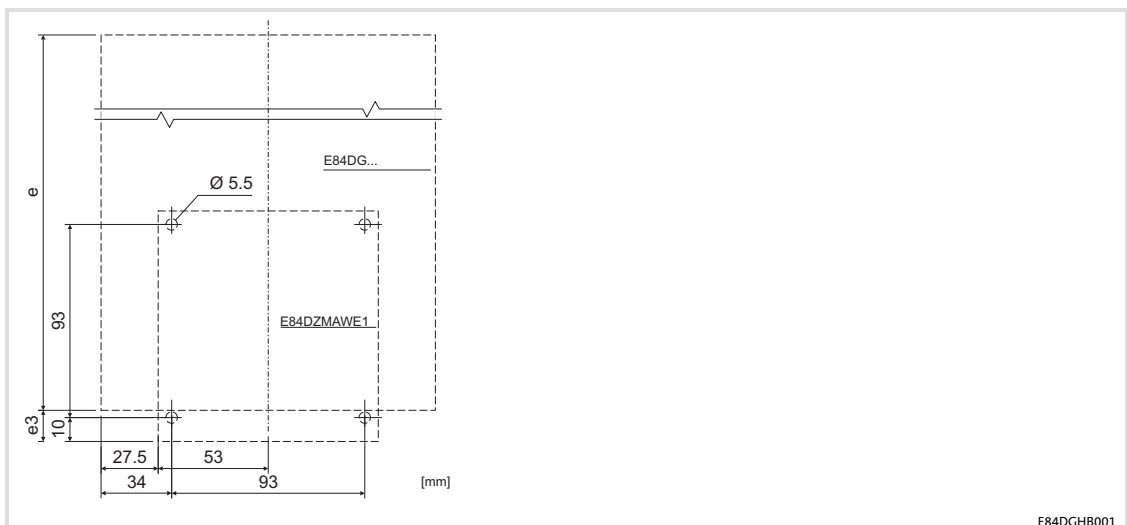

E84DGH001



#### **Danger!**

##### **Dangerous electrical voltage**

All power terminals remain live for up to three minutes after mains disconnection.

##### **Possible consequences:**

- ▶ Death or severe injuries when touching the power terminals.

##### **Protective measures:**

- ▶ Switch off the power supply and wait for at least three minutes before working on the power terminals.
- ▶ Make sure that all power terminals are deenergised.



#### **Danger!**

##### **Dangerous voltage**

The leakage current to earth (PE) is  $> 3.5$  mA AC or  $> 10$  mA DC.

##### **Possible consequences:**

- ▶ Death or severe injuries when the device is touched in the event of a fault.

##### **Protective measures:**

- ▶ Implement the actions required in the EN 61800-5-1. Especially:
  - Fixed installation
  - PE connection must conform to standards (PE conductor diameter  $\geq 10$  mm<sup>2</sup> or PE conductor must be connected twice)



#### **Stop!**

##### **No device protection if the mains voltage is too high**

The mains input is not internally fused.

##### **Possible consequences:**

- ▶ Destruction of the device if the mains voltage is too high.

##### **Protective measures:**

- ▶ Observe the maximally permissible mains voltage.
- ▶ Fuse the device correctly on the supply side against mains fluctuations and voltage peaks.



### Stop!

The device contains components that can be destroyed by electrostatic discharge!

Before working on the device, the personnel must ensure that they are free of electrostatic charge by using appropriate measures.



### Stop!

#### Damage of the device

Mounting or dismounting of the controller, especially the Drive Unit can damage or destroy the device.

#### Possible consequences:

- ▶ The drive may respond in an uncontrolled manner and cause further damages.

#### Protective measures:

- ▶ Only mount or dismount the controller in deenergised status.



### Stop!

#### Pluggable terminal strips or plug connections

Plugging or removing the terminal strips or plug connections during operation may cause high voltages and arcing.

#### Possible consequences:

- ▶ Damage of the devices

#### Protective measures:

- ▶ Switch off device.
- ▶ Only plug or remove the terminal strips or plug connections in deenergised status.



### Stop!

#### Overvoltage at components:

In case of an earth fault in IT systems, intolerable overvoltages may occur in the plant.

#### Possible consequences:

Destruction of the device.

#### Protective measures:

Before using the controller in the IT system, remove the contact screws on the supply side and the motor side. (📖 5.7).

**5.2 Installation according to EMC (installation of a CE-typical drive system)****Design of the cables**

- ▶ It is imperative to comply with the regulations concerning minimum cross-sections of PE conductors. The cross-section of the PE conductor must be at least as large as the cross-section of the power connections.
- ▶ The cables used must comply with the approvals required for the location (e.g. UL).

**5.2.1 Shielding****Requirements**

- ▶ The effectiveness of a shielded cable is reached by:
  - Providing a good shield connection through large-surface shield contact.
  - Using only braided shields with low shield resistance made of tin-plated or nickel-plated copper braid.
  - Using braided shields with an overlap rate > 70 % and an overlap angle of 90 °.
  - Keeping unshielded cable ends as short as possible.

Use system cables or shielded cables for these connections:

- ▶ Motor
- ▶ External brake resistor (Ⓜ Mounting Instructions of the brake resistor)
- ▶ Motor holding brake (shielding is required when being integrated into the motor cable; connection to optional motor brake control)
- ▶ Motor temperature monitoring
- ▶ Analog signals (inputs and outputs; single-sided shield connection to the controller)
- ▶ Fieldbus communication (e.g. CANopen, PROFIBUS, ...)
- ▶ Safety system

The following connections need not be shielded:

- ▶ Mains
- ▶ 24-V supply
- ▶ Digital signals (inputs and outputs).
  - We recommend to use shielded cables for a cable length from approximately 5 m on or in environments with strong interferences.

**Connection system**

- ▶ Extensively apply shielding directly in the plugs.
- ▶ Apply shielding above EMC cable glands.



### 5.2.2 Motor cable

- ▶ Only use shielded motor cables with braids made of tinned or nickel-plated copper. Shields made of steel braids are not suitable.
  - The overlap rate of the braid must be at least 70 % with an overlap angle of 90 °.
- ▶ The cables used must correspond to the requirements at the location (e.g. EN 60204-1).
- ▶ Use Lenze system cables.
- ▶ Extensively apply the shielding in the plug and attach it in a way which ensures electrical conductivity.
- ▶ The motor cable is optimally installed if
  - it is separated from mains cables and control cables,
  - it only crosses mains cables and control cables at right angles,
  - it is not interrupted.
- ▶ If the motor cable must be opened all the same (e.g. due to chokes, contactors, or terminals):
  - The unshielded cable ends may not be longer than 100 mm (depending on the cable cross-section).
  - Install chokes, contactors, terminals etc. spatially separated from other components (with a min. distance of 100 mm).
  - Install the shield of the motor cable directly before and behind the point of separation to the mounting plate with a large surface.
- ▶ Connect the shield with a large surface to PE in the terminal box of the motor at the motor housing.
  - Metal EMC cable glands at the motor terminal box ensure a large surface connection of the shield with the motor housing.

## Wiring on the motor side

**Stop!**

The motor cable is highly susceptible to interference. Therefore you will achieve an optimum wiring on the motor side if you

- ▶ exclusively use shielded and low-capacitance motor cables.
- ▶ do **not** integrate any further cable into the motor cable (e.g. for blowers etc.).
- ▶ shield the supply cable for temperature monitoring of the motor (PTC or thermostat) and install it separately from the motor cable.

Special conditions allow you to integrate the supply cable for temperature monitoring of the motor into the motor cable: (📖 57)

**Danger!****Uncontrolled motor movements can occur**

If the motor cable is damaged, a short circuit between the brake control cables and the motor cables can cause motor movements with low torque.

**Possible consequences:**

- ▶ Personnel in the vicinity of the motor can be injured.

**Protective measures:**

- ▶ Install motor cable in a protected way (e.g. in a cable duct).

## 5.2.3

## Control cables

- ▶ Control cables must be shielded to minimise interference injections.
- ▶ Connect the shield correctly:
  - Connect the shield of digital input and output cables at both ends.
  - Connect the shield of analog input and output cables at one end (at the drive controller).
- ▶ To achieve an optimum shielding effect (in case of very long cables, with high interference) one shield end of analog input and output cables can be connected to PE potential via a capacitor (e.g. 10 nF/250 V) (see sketch).

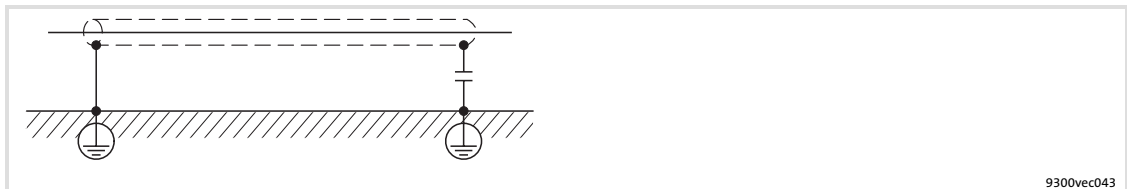

Fig. 5-1 Shielding of long, analog control cables

Installation according to EMC (installation of a CE-typical drive system)  
 Detecting and eliminating EMC interferences

### 5.2.4 Detecting and eliminating EMC interferences

Fault	Cause	Remedy
Interferences of analog setpoints of your own or other devices and measuring systems	Unshielded motor cable	Use shielded motor cable
	Shield contact is not extensive enough	Carry out optimal shielding as specified
	Shield of the motor cable is interrupted by terminal strips, switched, etc.	<ul style="list-style-type: none"> <li>● Separate components from other component part with a minimum distance of 100 mm</li> <li>● Use motor choke/motor filter</li> </ul>
	Install additional unshielded cables inside the motor cable (e.g. for motor temperature monitoring)	Install and shield additional cables separately
	Too long and unshielded cable ends of the motor cable	Shorten unshielded cable ends to maximally 40 mm

**5.3****Mechanical installation**

- ▶ If the cooling air is polluted (fluff, (conductive) dust, soot, aggressive gases), take adequate countermeasures, as e.g.:
  - Regular cleaning of the cooling ribs at the controller
  - Separate air guide
- ▶ Possible mounting position:
  - Observe information on mounting conditions in the chapter "Technical data".
- ▶ Maintain the specified free spaces above and below the controller to other installations!
- ▶ Ensure untroubled cooling and exhaust air flow.
  - Arrangement of several devices only to the sides

For mounting, use the screws of the motor terminal box. The installation material must ensure a durable mechanical connection.

If screws must be replaced, we recommend the following, depending on the motor frame size:

- ▶ M4/M5/M6 cheese head screw, hexagon socket, according to DIN 912/ISO 4762
- ▶ M4/M5/M6 cheese head screw, torx, according to ISO 14579

5.4 Electrical installation

5.4.1 Power connections

Principle circuit diagram

0.37 ... 3 kW

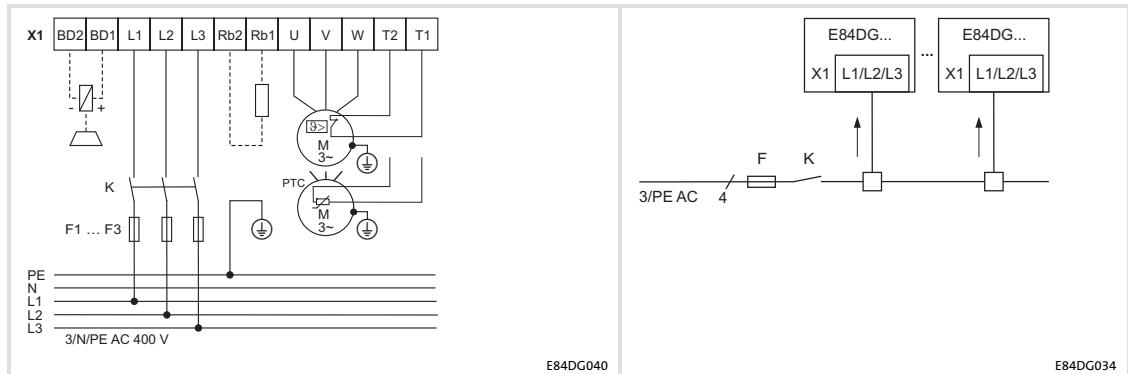

4 ... 7.5 kW

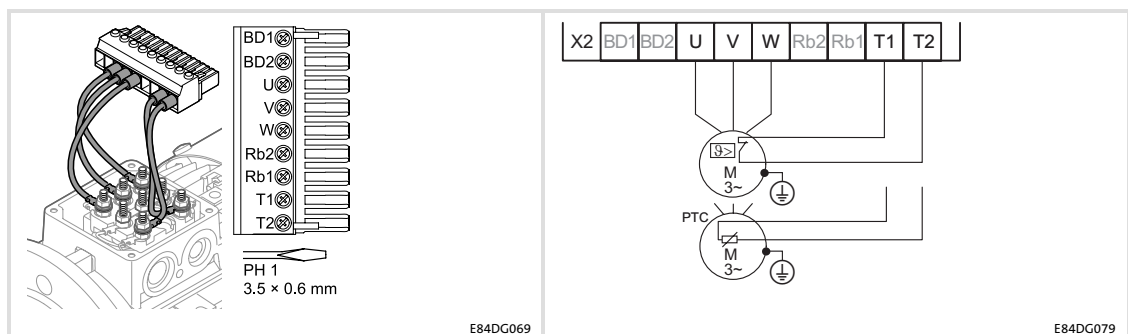

5.4.2

Wiring of control connections

Principle circuit diagram

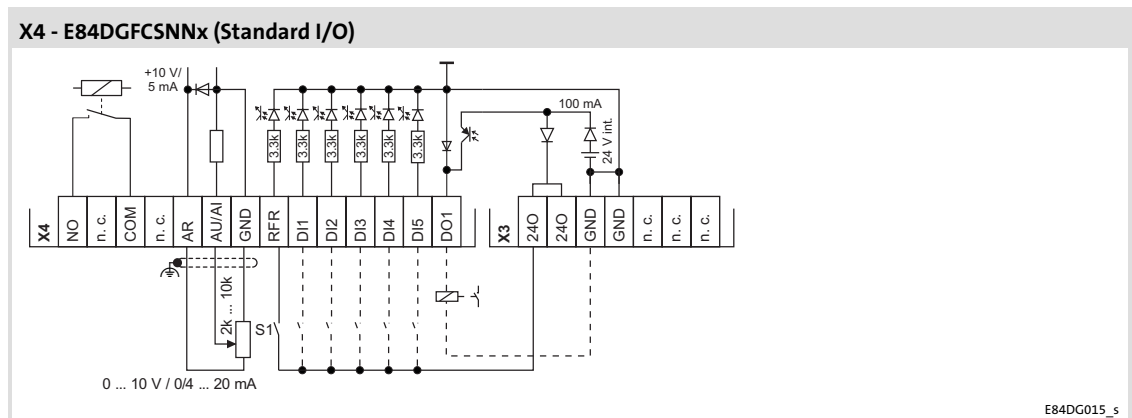
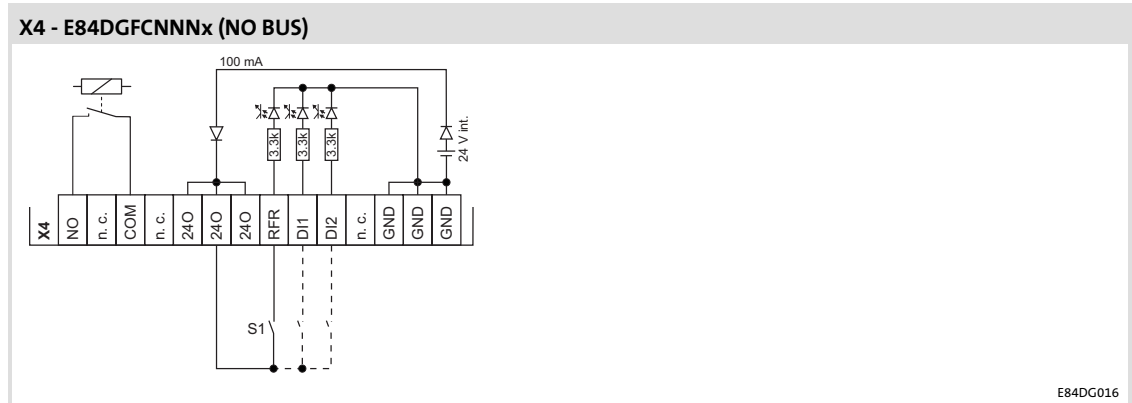

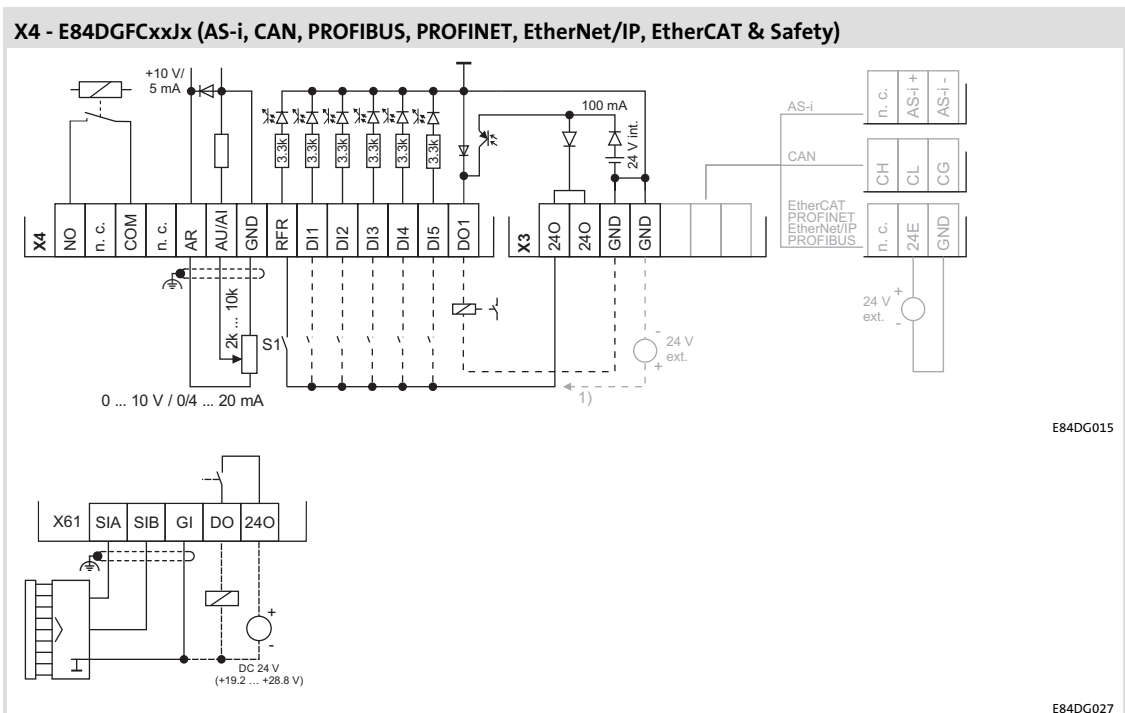
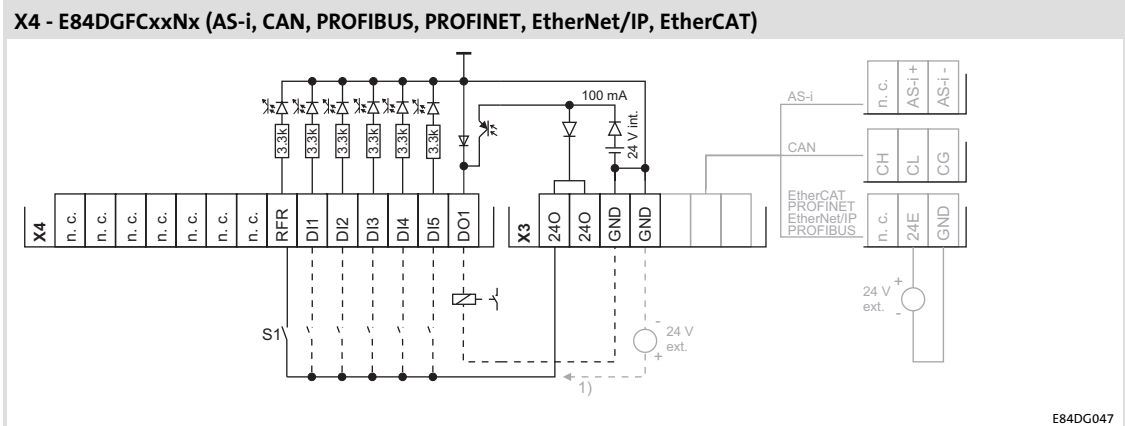

## 5

### Installation

Installation of 8400 motec pre-assembled on the motor  
Plug at the Wiring Unit

#### 5.5

##### Installation of 8400 motec pre-assembled on the motor

The worksteps to be done during the installation of pre-assembled 8400 motec controllers depend on the selected connection type of the Wiring Unit:

- ▶ Plugs
- ▶ Cable gland (M25)

#### 5.5.1

##### Plug at the Wiring Unit

The motor has already been wired with the Wiring Unit by the manufacturer. Make sure that the plug assignment of the mains cable complies with the plug at the Wiring Unit. You must plug on and lock the mains cable with the suitable plug.



## 5.5.2 Attaching the cable gland

### 0.37 ... 3 kW

In order to be able to screw the cable glands in the Wiring Unit and connect the mains cable, you must first dismount the Drive Unit and the Communication Unit as follows:

1. Loosen the four (captive) fixing screws of the motor inverter.
2. Remove the Drive Unit from the Communication Unit without twisting it.
3. Remove the already wired Communication Unit from plug-in connections or provide for sufficient free moving space of an available cable harness.
4. Unlock the Communication Unit (see fig. below). Remove the Communication Unit and position it such that the Wiring Unit can be freely accessed for wiring.
5. Unscrew screw-type blank cap and replace by cable gland. Restore the sealing requirements.
6. Insert mains cable and wire with L1 ... L3 and the earth connection  $\oplus$ .
  - The same procedure applies to a subsequent connection of another mains cable for loop-through or a cable for an external brake resistor.
  - For an installation of the controller conforming to standards, the second earth connection  $\oplus$  can be used for an additional equipotential bonding.
7. Mount the Communication Unit and the Drive Unit in reversed order of the described steps.

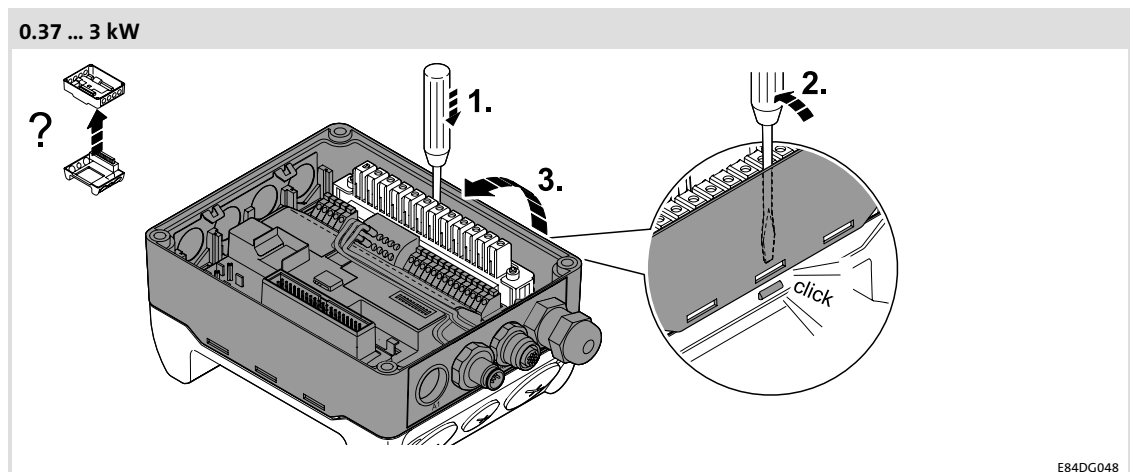

**4 ... 7.5 kW**

In order to be able to screw the cable glands into the Drive Unit and connect the mains cable, you must first dismount the Communication Unit as follows:

1. Remove the already wired Communication Unit from plug-in connections or provide for sufficient free moving space of an available cable harness.
2. Loosen the four (captive) screws of the cover of the Communication Unit completely and remove the cover.
3. Pull the hinged socket connector carefully from the counter plug and turn it into an upright position. Remove the Communication Unit abziehen and position it in such a way that the Drive Unit is sufficiently freely accessible for wiring.
4. Unscrew screw-type blank cap and replace by cable gland. Restore the sealing requirements.
5. Insert mains cable and wire with L1 ... L3 and the earth connection  $\oplus$ .  
– The same procedure applies to a subsequent connection of another mains cable for loop-through or a cable for an external brake resistor.
6. Re-assemble the frequency inverter in reversed order of the described steps.

## 5.6 Retrofitting the 8400 motec controller

8400 motec motor inverters for retrofitting existing drives and motors are supplied as set so that they can be mounted directly without previous dismounting. A set consists of components which are packaged and marked separately:

- ▶ Wiring Unit, marked with ① - WU
- ▶ Communication Unit, marked with ② - CU
- ▶ Drive Unit, marked with ③ - DU
- ▶ Accessories (optional), marked with ④ - opt x

Before working on an existing drive, make sure that the system is isolated from supply and protected against restart.

### 5.6.1 Preparing a motor for the 8400 motec installation

In order to install the 8400 motec, you must first remove the terminal box housing. In case of a standard motor, proceed as follows:

1. After loosening the screws, remove the terminal box cover.
2. Loosening the screws of the terminal box housing. Keep the screws for later fastening of the WU.
3. Remove the terminal box housing and make sure that the seal for the terminal box flange is kept for further use with the WU.
4. Usually, no measures have to be taken at the motor terminal block to mount the WU.

**5.6.2 Mounting the Wiring Unit****0.37 ... 3 kW**

Before being mounted, the WU can be extended with accessories. If there is sufficient space, accessories can also be mounted subsequently if required. The plug connector in the WU should be removed for easier handling and later wiring.

Proceed as follows:

1. Remove the plug connector.
2. Remove the blanking plugs from the WU that are to be replaced by cable glands or accessories for plug connection.
3. Mount the cable glands or the accessories for plug connection considering the sealing requirements.
4. Mount the WU onto the terminal box flange with the existing seal and screws. Earthing is achieved by forced contacting.
5. Install the mains connection cable and, if required, additional cables for the external brake resistor and/or motor holding brake.
6. Wire the mains connection, the brake resistor and/or motor holding brake (if required) to the plug connector. The PE conductor of the mains cable must be connected to one of the earthing connectors  $\oplus$  in the WU.
  - For an installation of the controller conforming to standards, the second earth connection  $\oplus$  can be used for an additional equipotential bonding.
7. Let the plug connector of the WU snap into place at the defined position.

The mounting of the WU is now completed mechanically and electrically.

#### 4 ... 7.5 kW

The Wiring Unit is mounted to the Drive Unit by means of the four supplied screws and the seal. In the case of this device size, accessories are mounted to the Drive Unit. If there is sufficient space, it is also possible to mount accessories subsequently. The plug connectors of the Wiring Unit are enclosed loosely.

Proceed as follows:

1. Mount the Wiring Unit to the Drive Unit.
2. Mount the Wiring Unit (with mounted Drive Unit) to the terminal box flange with the supplied seal and the original screws. Earthing is achieved by means of forced contact.
3. Install the mains connection cable and, if required, additional cables for the external brake resistor and/or motor holding brake.
4. Wire the mains connection, the brake resistor and/or motor holding brake (if required) to the plug connector. The PE conductor of the mains cable must be connected to one of the earthing connectors (⏚) in the Drive Unit.
  - For an installation of the controller conforming to standards, the second earth connection (⏚) can be used for an additional equipotential bonding.
5. Plug the plug connectors of the Wiring Unit onto the Drive Unit.

The mounting of the Wiring Unit and the Drive Unit is now completed mechanically and electrically.

### 5.6.3 Mounting of the Communication Unit

#### 0.37 ... 3 kW

The CU can be extended with accessories before being mounted. Additional cable glands or M12 connectors for further input and output signals can be mounted.

How to proceed:

1. In order to protect the CU electronics from damage, it must be unhooked and separated from the CU frame.
2. Open the prepared bushings as required. Use a suitable tool, e.g. a big screwdriver or step drill, to remove the areas from inside out. If required, plane rough edges.
3. Insert a connector M12 or cable gland with seal and screw down.
4. Position the CU frame onto the WU. The CU can be rotated by 180° in order that the position of the cable outlets meets the requirements of the local conditions.
5. Insert the CU electronics and let it snap into place.
6. Wire the additional signals.
7. If a fieldbus is used, where address and transmission speed can be set, they must be set right now since later settings are only possible after dismantling the DU.

The mounting of the CU is now completed mechanically and electrically.

**4 ... 7.5 kW**

The CU can be extended with accessories before being mounted. Additional cable glands or M12 connectors for further input and output signals can be mounted.

How to proceed:

1. Turn the hinged socket connector into an upright position.
2. In order to protect the CU electronics from damage, it must be unhooked and separated from the CU frame.
3. Open the prepared bushings as required. Use a suitable tool, e.g. a big screwdriver or step drill, to remove the areas from inside out. If required, plane rough edges.
4. Insert a connector M12 or cable gland with seal and screw down.
5. Position the CU frame onto the DU aufsetzen. The CU can be rotated by 180° in order that the position of the cable outlets meets the local requirements in an optimal way.
6. Insert the CU electronics and let it snap into place.
7. Wire the additional signals.
8. Turn the hinged socket connector towards the CU and carefully insert it into the counter plug.
9. If a fieldbus is used, where address and transmission speed can be set, they must be set right now since later settings are only possible after dismantling the cover.
10. Mount the cover of the Drive Unit to the CU with four screws (5.0 Nm/44 lb-in).

The mounting of the CU is now completed mechanically and electrically.

**5.6.4 Settings at the Drive Unit**

Besides parameter setting of the DU via diagnosis terminal (keypad with cable connection) or parameter setting using the »Engineer«, some features can be set directly (📖 76).

**5.6.5 Mounting of the Drive Unit****0.37 ... 3 kW**

If all previous steps have been executed and completed, the DU can be mounted.

How to proceed:

1. Position the DU in parallel to the WU and CU without twisting it. The four fixing screws show the correct position if they are put through the locating holes of the CU into the threads of the WU.
2. The connectors are contacted with light pressure and the DU has reached the final position.
3. Tighten the four fixing screws (5.0 Nm/44 lb-in)

The installation is completed.

**4 ... 7.5 kW**

The DU has already been mounted with the WU and is completed by attaching the cover to the CU.

Measures when drive is used in IT systems

### 5.7 Measures when drive is used in IT systems

If the drive is mounted within an IT system, internal filters must be separated from the PE conductor.

How to proceed:

1. If the controller has already been mounted: switch off mains voltage!
2. Make IT screw accessible.
  - Devices up to 3 kW: unscrew small cap on the top.
  - Devices from 4 kW: remove small cover on the top.
3. Unscrew and remove the screw(s).
4. Screw the cap on or fit the cover.

#### IT system

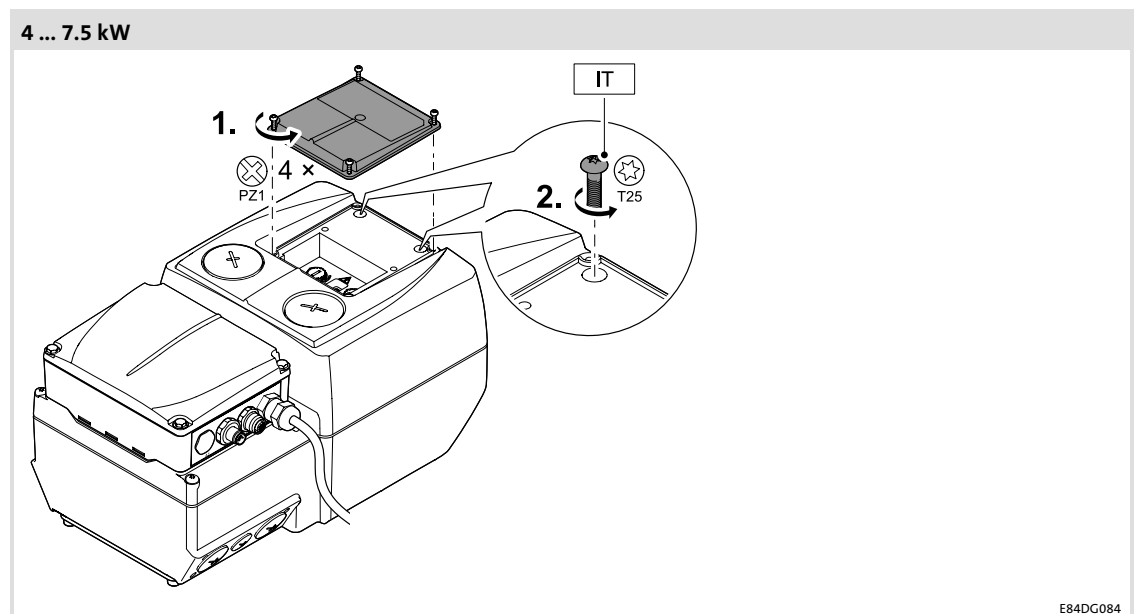
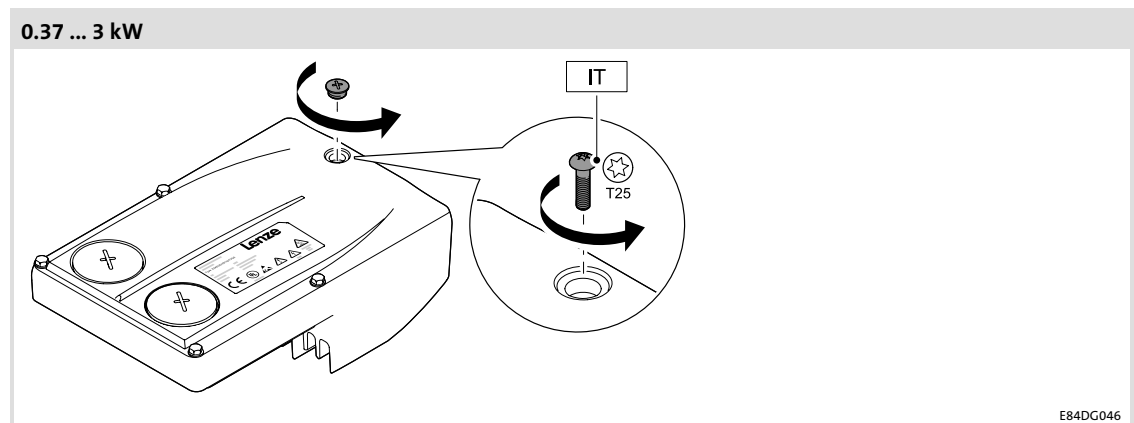



## 5.8 Wall mounting of 8400 motec controller

Wall mounting requires optional accessories:

- ▶ 0.37 ... 3.0 kW: E84DZMAWE1

Before working on an existing drive, make sure that the system is isolated from supply and protected against restart.

First attach the wall adapter to a suitable position.

For an installation of the controller conforming to standards, the PE conductor connector can be used for an additional equipotential bonding.

The following mounting steps of the 8400 motec motor inverter corresponds to the retrofitting procedure.

Additional workstep when the Wiring Unit is wired:

- ▶ Laying and connection of the motor cable, with temperature monitoring if required.

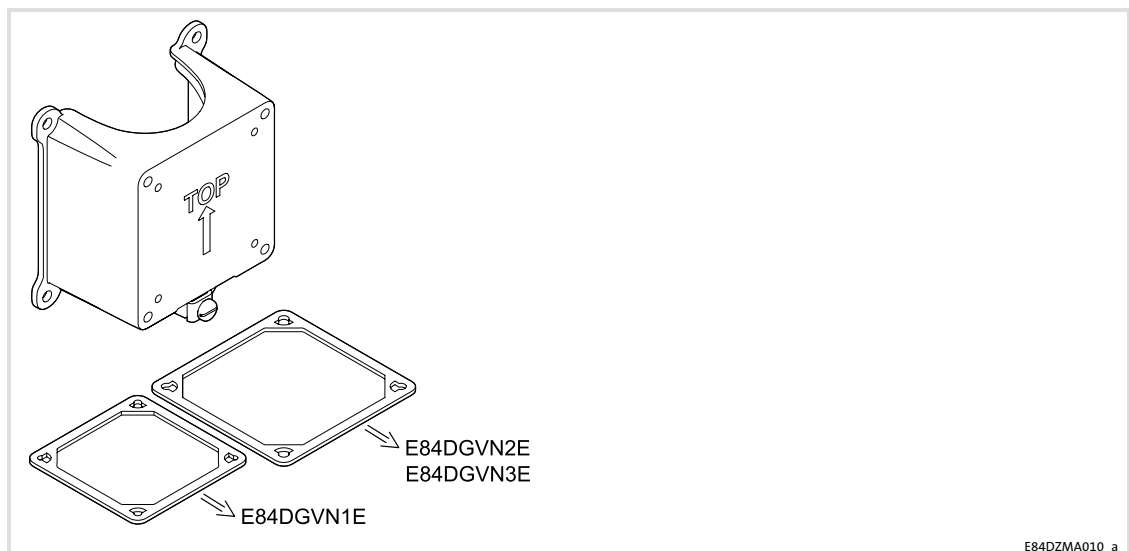

## 6 Commissioning

Before switching on

## 6 Commissioning



### Note!

- ▶ Please observe the general safety instructions (📖 12).
- ▶ Please observe the notes regarding residual hazards (📖 18).

### 6.1 Before switching on

#### Selection of the appropriate commissioning tool



### Tip!

Use the »Engineer« to carry out extensive parameter setting and configuration. The online help which is available for each device and the accompanying software documentation will assist you.

The 8400 motec keypad (diagnosis terminal version) can be used for quick commissioning and checking individual parameters on the controller.

## Notes for motor operation



### Danger!

- ▶ For thermal reasons, continuous operation of self-ventilated motors at low field frequency and rated motor current is not permissible. If required, activate a motor temperature monitoring with C00585
  - motor temperature monitoring with  $I^2xt$  (see software manual)
  - motor temperature monitoring with motor PTC (see software manual).
- ▶ When setting the V/f base frequency (C00015), please observe the following difference to the 8400 StateLine/HighLine/TopLine controllers:  
For the 8400 motec drive, the reference voltage for the V/F base frequency is the rated motor voltage (C00090) according to the motor nameplate (independently of the line-side supply voltage).



### Tip!

In the Lenze setting, the "linear V/f characteristic" operating mode is set as motor control. The parameter settings are preset so that if the frequency inverter and the 50 Hz asynchronous machine match in terms of power, the controller is ready for operation without any further need for parameterisation and the motor operates satisfactorily.

Recommendations for the following application cases

- ▶ If the frequency inverter and the motor differ strongly in terms of power
  - Set code C00022 ( $I_{max}$  limit in motor mode) to  $2.0 I_{N(motor)}$ .
- ▶ If a high starting torque is required
  - When the motor is idling, set the code C00016 ( $V_{min}$  boost) so that a rated motor current flows with a field frequency  $f = 3$  Hz (C00058).
- ▶ For noise reduction
  - Set code C00018 to the value "3" (switching frequency  $16 \text{ kHz}_{sin var}$ ).
- ▶ If a high torque without feedback is to be available at low speeds, we recommend the "vector control" mode.

### 6.2 Quick commissioning



#### Stop!

##### Automatic motor start

In "Local mode" The auto-start option "Inhibit at power-on" is not set. When the mains is connected, the motor starts if the controller enable RFR is bridged or set.

("Local mode" => DIP1/1 = ON and DIP2/5-7 = OFF)

##### Possible consequences:

- ▶ Danger or damages through unexpected motor start.

##### Protective measures:

- ▶ Decouple the motor from the drive train during commissioning phase.
- ▶ Replace the factory-set bridge at RFR by an NO contact.
- ▶ Do not set controller enable.

### 6.2.1 General configuration settings

For initial commissioning, settings can be made via DIP switch and potentiometer. The settings must be made before mounting the drive unit since the setting elements cannot be accessed from the outside.

#### Setting elements 0.37 ... 3 kW

The setting elements are located on the inner side of the drive unit.

Settings carried out via DIP1, DIP2, P2, P3, and P1 must be activated with DIP1/1. The settings are accepted again at every mains connection. Thus, changes on parameters made in the meantime may be overwritten.

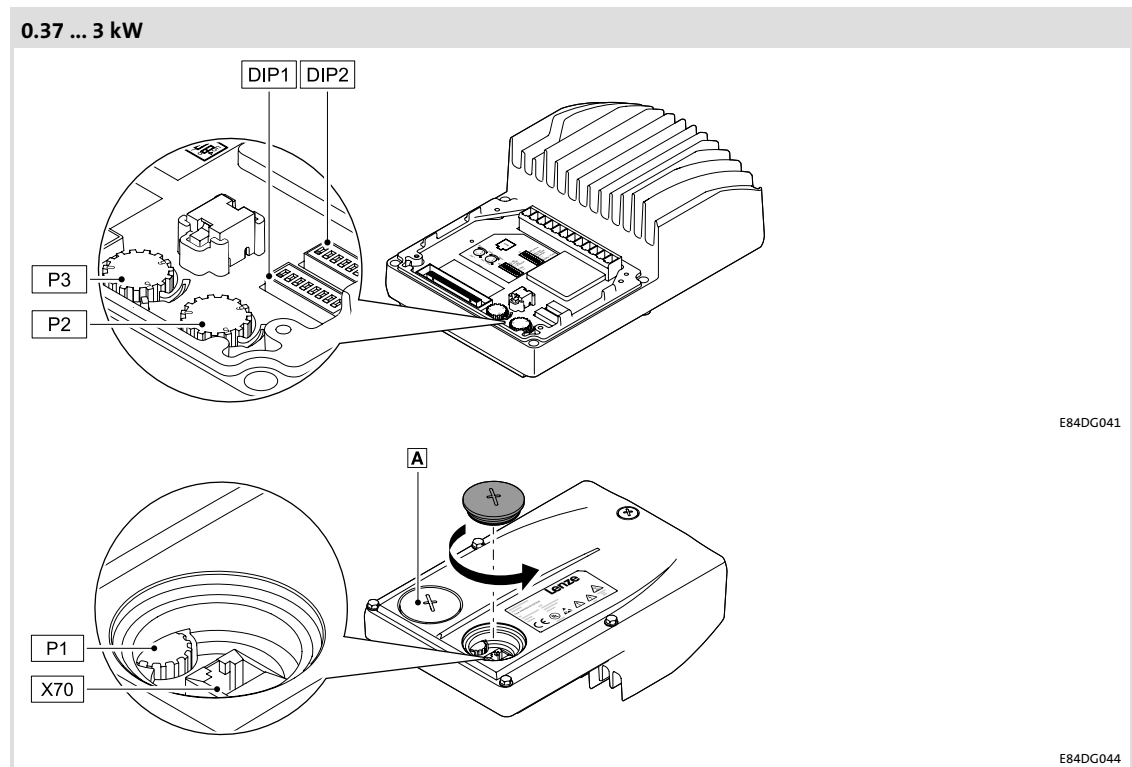

	Name
DIP1	Switch for basic setting of quick commissioning
DIP2	
P1	Setting "Top Cover: Speed ... %"
P2	Setting "Speed ... %", (speed)
P3	Setting "Ramp ... s", (acceleration/deceleration time)
X70	Connection for USB diagnostic adapter E94AZCUS or diagnosis terminal
A	LED status display

## Commissioning

Quick commissioning

General configuration settings

### Setting elements 4 ... 7.5 kW

The setting elements are located on the top of the drive unit.

- ▶ Provide for isolation from supply and secure to prevent a restart.
- ▶ Remove small cover on the top.

Settings carried out via DIP1, DIP2, P2, P3, and P1 must be activated with DIP1/1. The settings are accepted again at every mains connection. Thus, changes on parameters made in the meantime may be overwritten.

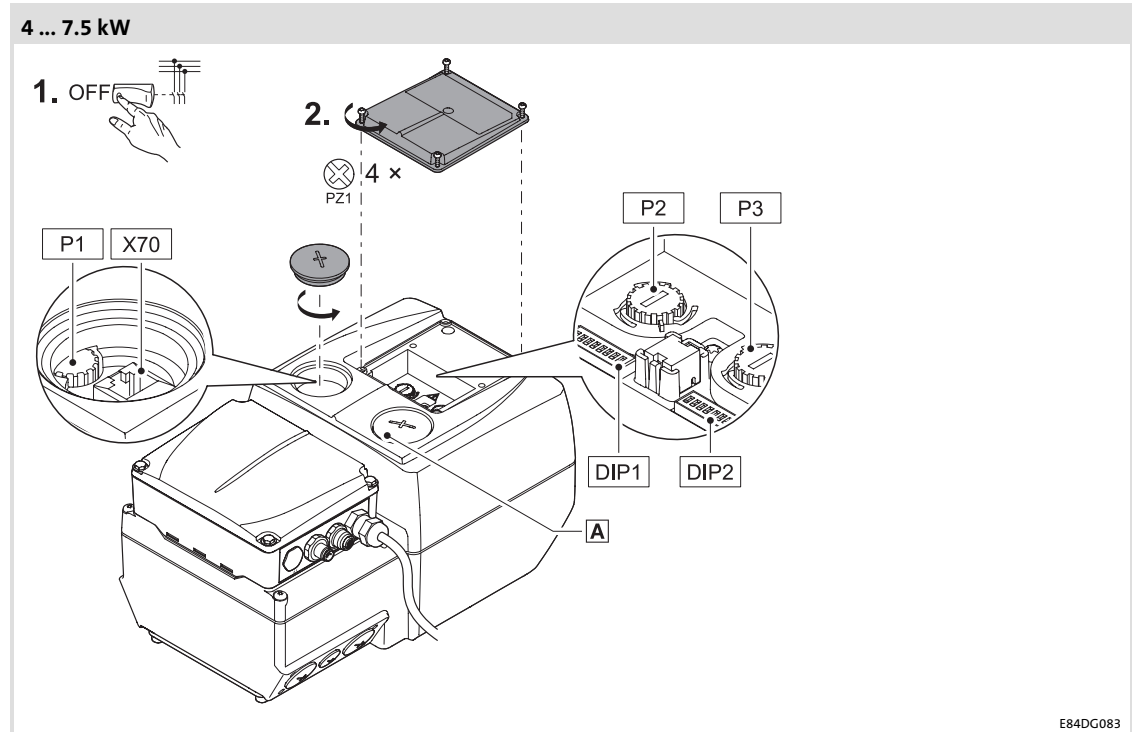

	Name
DIP1	Switch for basic setting of quick commissioning
DIP2	
P1	Setting "Top Cover: Speed ... %"
P2	Setting "Speed ... %", (speed)
P3	Setting "Ramp ... s", (acceleration/deceleration time)
X70	Connection for USB diagnostic adapter E94AZCUS or diagnosis terminal
A	LED status display

Possible settings with DIP1 (Lenze setting **bold**)

<b>DIP1</b>		<b>Switch</b>							
<b>Description</b>		<b>1</b>	<b>2</b>	<b>3</b>	<b>4</b>	<b>5</b>	<b>6</b>	<b>7</b>	<b>8</b>
Settings after DIP1, DIP2, P1, P2, and P3 active	on (1)	ON							
	<b>off (0)</b>	<b>OFF</b>							
Direction of rotation	left		ON						
	<b>right</b>		<b>OFF</b>						
Control	quadratic			ON					
	<b>linear</b>			<b>OFF</b>					
Flying restart circuit	on (1)				ON				
	<b>off (0)</b>				<b>OFF</b>				
<i>Reserved</i>	-					OFF	OFF	OFF	
Message type -> on (only optional with Communication Unit "+ Safety")	fail -> DO								ON
	ready -> NO (relay)								
	<b>ready -&gt; DO</b>								<b>OFF</b>
	<b>fail -&gt; NO (relay)</b>								

Possible settings with DIP2

<b>DIP2</b>		<b>Switch</b>							
<b>Description</b>		<b>1</b>	<b>2</b>	<b>3</b>	<b>4</b>	<b>5</b>	<b>6</b>	<b>7</b>	<b>8</b>
Rated motor frequency	<b>50 Hz</b>	<b>OFF</b>	<b>OFF</b>						
	60 Hz	ON	OFF						
	87 Hz	OFF	ON						
	120 Hz	ON	ON						
Mode of the analog input (only optional with Communication Unit "+ Safety")	<b>0 ... 10 V</b>			<b>OFF</b>	<b>OFF</b>				
	0 ... 20 mA			ON	OFF				
	4 ... 20 mA			OFF	ON				
	not permissible			ON	ON				
Control mode of technology application (cf. selection C00007)	<b>9 (local mode)</b>					<b>OFF</b>	<b>OFF</b>	<b>OFF</b>	
	10 (terminals 0)					ON	OFF	OFF	
	12 (terminals 2)					OFF	ON	OFF	
	14 (terminals 11)					ON	ON	OFF	
	16 (terminals 16)					OFF	OFF	ON	
	Reserved					ON	OFF	ON	
	Reserved					OFF	ON	ON	
	40 (MCI)					ON	ON	ON	
<i>Reserved</i>	-								<b>OFF</b>

Control modes DIP2/5-7	Description (Dlx → High)															
9 (local mode)	<p>The technology application is controlled locally via elements on the controller and the digital input terminals:</p> <p><b>⚠ At mains connection the motor starts up automatically if RFR is bridged or set!</b></p> <table border="1"> <tr> <td>DI1</td> <td>Setpoint of P2 (speed)</td> <td>Fixed setpoint 3</td> </tr> <tr> <td>DI2</td> <td>Fixed setpoint 2</td> <td></td> </tr> <tr> <td>DI3</td> <td>Activate DC injection brake</td> <td></td> </tr> <tr> <td>DI4</td> <td>Change of direction of rotation (not possible if DIP1/2 = on (set to the left))</td> <td></td> </tr> <tr> <td>DI5</td> <td>Release holding brake manually (operating mode after setting C02580)</td> <td></td> </tr> </table>	DI1	Setpoint of P2 (speed)	Fixed setpoint 3	DI2	Fixed setpoint 2		DI3	Activate DC injection brake		DI4	Change of direction of rotation (not possible if DIP1/2 = on (set to the left))		DI5	Release holding brake manually (operating mode after setting C02580)	
DI1	Setpoint of P2 (speed)	Fixed setpoint 3														
DI2	Fixed setpoint 2															
DI3	Activate DC injection brake															
DI4	Change of direction of rotation (not possible if DIP1/2 = on (set to the left))															
DI5	Release holding brake manually (operating mode after setting C02580)															
10 (terminals 0)	<p>The technology application is controlled via the digital input terminals of the controller:</p> <table border="1"> <tr> <td>DI1</td> <td>Fixed setpoint 1</td> <td>Fixed setpoint 3</td> </tr> <tr> <td>DI2</td> <td>Fixed setpoint 2</td> <td></td> </tr> <tr> <td>DI3</td> <td>Activate DC injection brake</td> <td></td> </tr> <tr> <td>DI4</td> <td>Change of direction of rotation</td> <td></td> </tr> <tr> <td>DI5</td> <td>Release holding brake manually (operating mode after setting C02580)</td> <td></td> </tr> </table>	DI1	Fixed setpoint 1	Fixed setpoint 3	DI2	Fixed setpoint 2		DI3	Activate DC injection brake		DI4	Change of direction of rotation		DI5	Release holding brake manually (operating mode after setting C02580)	
DI1	Fixed setpoint 1	Fixed setpoint 3														
DI2	Fixed setpoint 2															
DI3	Activate DC injection brake															
DI4	Change of direction of rotation															
DI5	Release holding brake manually (operating mode after setting C02580)															
12 (terminals 2)	<p>The technology application is controlled via the digital input terminals of the controller:</p> <table border="1"> <tr> <td>DI1</td> <td>Fixed setpoint 1</td> <td>Fixed setpoint 3</td> </tr> <tr> <td>DI2</td> <td>Fixed setpoint 2</td> <td></td> </tr> <tr> <td>DI3</td> <td>Quick stop</td> <td></td> </tr> <tr> <td>DI4</td> <td>Change of direction of rotation</td> <td></td> </tr> <tr> <td>DI5</td> <td>Release holding brake manually (operating mode after setting C02580)</td> <td></td> </tr> </table>	DI1	Fixed setpoint 1	Fixed setpoint 3	DI2	Fixed setpoint 2		DI3	Quick stop		DI4	Change of direction of rotation		DI5	Release holding brake manually (operating mode after setting C02580)	
DI1	Fixed setpoint 1	Fixed setpoint 3														
DI2	Fixed setpoint 2															
DI3	Quick stop															
DI4	Change of direction of rotation															
DI5	Release holding brake manually (operating mode after setting C02580)															
14 (terminals 11)	<p>The technology application is controlled via the digital input terminals of the controller:</p> <table border="1"> <tr> <td>DI1</td> <td>Change of direction of rotation</td> <td></td> </tr> <tr> <td>DI2</td> <td>Activate DC injection brake</td> <td></td> </tr> <tr> <td>DI3</td> <td>Motor potentiometer: speed higher</td> <td></td> </tr> <tr> <td>DI4</td> <td>Motor potentiometer: speed lower</td> <td></td> </tr> <tr> <td>DI5</td> <td>Release holding brake manually (operating mode after setting C02580)</td> <td></td> </tr> </table>	DI1	Change of direction of rotation		DI2	Activate DC injection brake		DI3	Motor potentiometer: speed higher		DI4	Motor potentiometer: speed lower		DI5	Release holding brake manually (operating mode after setting C02580)	
DI1	Change of direction of rotation															
DI2	Activate DC injection brake															
DI3	Motor potentiometer: speed higher															
DI4	Motor potentiometer: speed lower															
DI5	Release holding brake manually (operating mode after setting C02580)															
16 (terminals 16)	<p>The technology application is controlled via the digital input terminals of the controller:</p> <table border="1"> <tr> <td>DI1</td> <td>Fixed setpoint 1</td> <td>Fixed setpoint 3</td> </tr> <tr> <td>DI2</td> <td>Fixed setpoint 2</td> <td></td> </tr> <tr> <td>DI3</td> <td>CW rotation/quick stop</td> <td></td> </tr> <tr> <td>DI4</td> <td>CCW rotation/quick stop</td> <td></td> </tr> <tr> <td>DI5</td> <td>Release holding brake manually (operating mode after setting C02580)</td> <td></td> </tr> </table>	DI1	Fixed setpoint 1	Fixed setpoint 3	DI2	Fixed setpoint 2		DI3	CW rotation/quick stop		DI4	CCW rotation/quick stop		DI5	Release holding brake manually (operating mode after setting C02580)	
DI1	Fixed setpoint 1	Fixed setpoint 3														
DI2	Fixed setpoint 2															
DI3	CW rotation/quick stop															
DI4	CCW rotation/quick stop															
DI5	Release holding brake manually (operating mode after setting C02580)															
40 (MCI)	<p>The technology application is controlled via fieldbus communication.</p> <p>Depending on the Communication Unit available</p>															



Possible settings with P2 "Speed"

With P2, a motor speed setpoint in percent of the rated speed in C00011 can be preset in 10 steps (JOG fixed setpoint). The JOG setpoint is only activated if input DI1 is set in "Local mode".

P2	Setting									
Description	0	1	2	3	4	5	6	7	8	9
Motor speed in percent of the rated speed setting [%] C00011	0	11	22	33	44	55	66	77	88	100

Possible settings with P3 "Ramp"

P3	Setting									
Description	0	1	2	3	4	5	6	7	8	9
Acceleration or deceleration time of the motor in seconds [s]	0.1	0.5	1	2	5	10	20	30	60	120

Possible settings with P1

Potentiometer P1 can be accessed after the cover has been removed. In order to ensure the degree of protection of the controller, the cover has to be screwed in again after the settings have been made.

During operation, P1 can be used to steplessly set the motor speed in percent of the rated speed in C00011 if no JOG fixed setpoint P2 is active via DI1.

P1	Setting		
Description	0	...	9
Motor speed in percent of the rated speed C00011 [%]	0	...	100

**Preconditions for initial switch-on**

- ▶ The wiring unit is mounted and wired according to the instructions,
  - directly on a motor clamping flange or
  - with the wall adapter on a suitable surface near the motor.
- ▶ Connections with the mains, motor, holding brakes, etc. have been established.
- ▶ The communication unit has been mounted and wired according to the scheduled application.
  - Input and output signals
  - Safe input
  - Fieldbus
 (depending on the version, only available optionally)
- ▶ If required, the basic settings for "local mode" have been carried out.
  - DIP switches
  - Potentiometer
- ▶ The drive unit has been mounted and screwed together.
- ▶ Use available control functions reasonably, e.g.
  - Inhibit controller enable
  - Set speed adjustment to the minimum setting
  - Activate safety system
- ▶ The use of a brake resistor has been checked.
  - In the case of dynamic loads or difficult control conditions, the use of the internal brake resistor E84DZEW47R0 is always recommended for the devices E84DGDVB4024 ... 7524 (4 ... 7.5 kW).

**Danger!****High hazard potential during commissioning**

Incorrect settings may cause unexpected and dangerous motor and system movements.

**Possible consequences:**

- ▶ Damage to material assets
- ▶ Injury to persons

**Protective measures:**

- ▶ Clear hazardous area
- ▶ Observe safety instructions and safety clearances

## 6.2.2 Commissioning steps

### Commissioning

Proceed step by step:

- ▶ Switch on the mains
- ▶ Observe status display
  - After a short initialisation time, the display must be blinking green.
- ▶ Deactivate requirements of the safety function
- ▶ Set controller enable
  - After the set starting time, the motor must rotate with the set speed.
- ▶ First check of the expected behaviour:
  - Direction of rotation?
  - Starting time?
  - Speed?
  - Speed control?
- ▶ Check of optional control functions:
  - Does the analog setpoint selection work?
  - Do the digital control signals, e.g. limit switches, work?
  - Does the connected motor holding brake work?
  - Does the change of direction of rotation work?
  - Does the requirement of the safety function work?
  - Do the control signals over fieldbus work?
- ▶ Switch off drive
  - Reduce speed
  - Inhibit controller enable
  - Switch off mains



#### **Note!**

##### **Save parameter settings safe against mains failure**

In order to prevent parameter settings carried out in the device from being lost by mains switching, you have to explicitly save the parameter set with mains failure protection in the device.

#### 6.3 Handling of the keypad

The keypad X401 serves to quickly and easily set parameters and display current actual values and device states by means of the corresponding display parameters. For this purpose, the keypad must be plugged onto the diagnostic interface on the top of the device.



#### Danger!

##### Uncontrolled motor movement possible

In general, changing a parameter causes an immediate response in the controller.

##### Possible consequences:

- ▶ This may lead to undesirable behaviour on the motor shaft if the controller has been enabled.

##### Protective measures:

- ▶ Make changes in small steps and wait for response.
- ▶ Certain device commands or settings which may cause critical states of drive behaviour constitute exceptions. Such parameter changes are only possible if the controller is inhibited. Otherwise, a corresponding error message will be issued.



#### Note!

The keypad can also be inserted/removed during operation.



#### Further information ....

Further information on the keypad can be found in the operating instructions supplied with the keypad!

#### Menu structure

The main menu of the keypad contains the following entries:

Menu item	Function
User menu	Display of a selection of frequently required parameters.
Code list	Display of the parameter list with all parameters.
Go to parameter	Directly calls a certain parameter.
Local operation	Control of the controller via the keypad keys.
Status	Status display (current speed, motor current, device status).

### User menu

The user menu can be freely configured in C00517 and contains the following parameters in the Lenze setting:

Parameter	Name	Info	Lenze setting	
			Value	Unit
C00002/19	Device command: Reset error	After resetting the current error, further errors may be pending which must be reset as well. Details of the current error are displayed in C00166.	0	-
C00007	Control mode	Selection of how the application is to be controlled.	10	-
C00011	Appl.: Reference speed	Setting the reference speed	1500	rpm
C00012	Accel. time - main setpoint	FB L_NSet_1: Acceleration time of the ramp generator for the main speed setpoint	2.0	s
C00013	Decel. time - main setpoint	FB L_NSet_1: Deceleration time of the ramp generator for the main speed setpoint	2.0	s
C00015	VFC: V/f base frequency	V/f base frequency for VFCplus motor control	50	Hz
C00016	VFC: Vmin boost	Boost of the V/f voltage characteristic within the range of low speed or frequency values for the VFCplus motor control.	2.6	%
C00022	I <sub>max</sub> in motor mode	Maximum current in motor mode for all motor control modes	5.8	A
C00039/1	Fixed setpoint 1 (L_NSet_1 n-Fix)	FB L_NSet_1: Fixed speed setpoints (JOG values) for the setpoint generator Fixed setpoint 1	40.0	%
C00039/2	Fixed setpoint 2	Fixed setpoint 2	60.0	%
C00039/3	Fixed setpoint 3	Fixed setpoint 3	80.0	%
C00087	Rated motor speed	This value can be obtained from the motor nameplate. After the motor to be used has been selected from the motor catalogue, the suitable value can be entered automatically.	1320	rpm
C00089	Rated motor frequency	This value can be obtained from the motor nameplate. After the motor to be used has been selected from the motor catalogue, the suitable value can be entered automatically.	50	Hz
C00105	Deceleration time - quick stop	The set deceleration time determines the ramp slope at quick stop	5.0	s
C00120	Motor overload threshold (I <sup>2</sup> xt)	Operating threshold for the error message "OC6: Motor overload (I <sup>2</sup> xt)"	100	%
C00129	Value brake resistor	Resistance value of the connected brake resistor	220	Ω
C00165	Error information	Display of the error numbers divided into sectors in the case of an error	-	-
C00173	Mains voltage	Selection of the mains voltage for operating the device.	0: 400 V	-
C02580	Holding brake: Operating mode	Selection of the operating mode for holding brake control	0: Off	-

### General operation

1. Select the desired menu using the navigation key  $\diamond/\diamond$ .
  - The navigation keys  $\diamond/\diamond$  serve to get one menu level higher/lower.
  - The function key  $\text{ESC}$  serves to get back to the main menu.
2. Select the parameter you want to set within a submenu using the navigation keys  $\diamond/\diamond$ .
3. Press the function key  $\text{EDIT}$  to change to the editing mode.
4. Set the desired value by means of the navigation keys.
  - Use the navigation keys  $\diamond/\diamond$  to move the cursor to the left/right.
  - Use the navigation keys  $\diamond/\diamond$  to change the marked digits.
5. Press the function key  $\text{OK}$  to accept the change carried out and quit the editing mode.
  - Use the function key  $\text{ESC}$  to quit the editing mode without accepting the changes.



### Tip!

Information on how to set parameters with the »Engineer« can be found in the »Engineer« online help.

## 6.4 Overview of the commissioning steps with keypad



### Note!

The following can be used at the diagnostic interface X70:

- ▶ Diagnosis terminal X401 (EZAEBK2003)
  - The described settings with the keypad X401 can also be carried out with the diagnosis terminal X401.
- ▶ USB diagnostic adapter (E94AZCUS)

### 6.4.1 Keypad control

Only some parameters must be adapted for the drive. Then the drive application can be controlled immediately in the preset control mode "Terminals 0" via the digital and analog inputs at the controller. Alternatively, the keypad can be used for defining the required setpoints and control signals in the "Keypad" control mode.

#### Commissioning steps

1. Wiring of power terminals
  - Make use of the mounting instructions supplied with the controller to wire the power terminals according to the requirements of your device.
2. Wiring of control terminals.
  - The preconfigured I/O connection can be changed via configuration parameters. See chapter "User-defined terminal assignment".
  - Assignment in the preset control mode "Terminals 0":

Terminal	Function	Info
A1U	Setpoint selection	10 V ≙ 1500 rpm (with 4-pole motor) general: 10 V ≙ 100 % reference speed (C00011)
DI1	JOG 1	Selection of fixed setpoints 1 ... 3 ● If both inputs are on LOW level, the setpoint selection via the analog input A1U is active.
DI2	JOG 2	
	JOG 3	
DI3	DCB	Manual DC-injection braking (DCB) ● For HIGH-active inputs, DC-injection braking is active as long as DI3 is at HIGH level. ● After the hold time (C00107) has expired, the controller sets the pulse inhibit (CINH). DC-injection braking (▶ 110)
DI4	R/L	LOW level: CW rotation HIGH level: CCW rotation
DI5	Holding brake	Open/close holding brake ● Braking modes C02580

## Commissioning

Overview of the commissioning steps with keypad  
Keypad control

3. Check switch at the bottom of the drive unit:  
DIP1/1 must be "OFF" (Lenze setting) in order that the parameters can be overwritten via »Engineer«, keypad, or fieldbus.
4. If required, carry out communication settings via the DIP switch on the Communication Unit for fieldbus communication.  
The communication settings depend on the fieldbus used.
5. Fasten the controller by means of the 4 screws.
6. Switch on voltage supply of the controller.
7. Connect keypad.
  - Remove the cover of the diagnostic interface on the top of the device and connect the keypad to the diagnostic interface.
  - After attaching the keypad or switching on the controller with keypad attached, the connection between keypad and controller is established. The process is completed when the code C00051 appears in the display.







Keypad display	Action
MCTRL: Act speed val. C00051  0 rpm	Use left function key  to change to main menu.

8. Load Lenze setting to controller.
  - For this purpose, the device command "Load Lenze setting" is available which can be executed via code C00002/1 with the keypad:



### Note!

If the Lenze settings are loaded, changed values are overwritten. Default settings for a specific motor, e.g. for a Drive Package, would be reset with "Load Lenze settings".

Keypad display	Action
Par1 8400 motec User menu ... Logbook Quick commissioning	A Use navigation key  to select the "Quick commissioning" menu in the main menu. B Use navigation key  to change to the "Quick commissioning" menu.
Par1 Quick commissioning Terminals Keypad	Use navigation key  to change to the "Terminals" menu.
Load Lenze setting C00002/1	A Use the left function key  to change to the editing mode for C00002/1. B Use navigation key  to select the "1: On/Start" entry in the selection list. C Use the right function key  to accept the executed change and quit the editing mode. – The load process may take a couple of seconds.



9. Enable controller: Set RFR to HIGH potential.

10. Select speed:

- In the "Terminals 0" by selecting a voltage at the analog input or by selecting a fixed setpoint via the digital inputs DI1/DI2.
- In the "Keypad" control mode, the main speed setpoint and the control signals are selected via the following parameters which are available in the "Quick commissioning → Keypad" menu level:

Parameter	Name	Info	Lenze setting	
			Value	Unit
C00728/3	nMainSetValue_a	Main setpoint for the application 100 % ≙ reference speed (C00011)	0.00	%
C00727/3	bSetSpeedCcw	Change of direction of rotation "0": CW rotation "1": CCW rotation	0	
C00727/4	bJogSpeed1	Selection of fixed setpoint 1 "0": Main setpoint (C00728/3) active. "1": Fixed setpoint 1 (C00039/1) active.	0	

11. If required, adapt further parameters.

- Short overview of the parameters for quick commissioning (📖 91)

12. Save parameter settings with function key **SAVE** safe against mains failure in the memory module.

**Note!**

In the Lenze setting, the V/f characteristic control (VFCplus) with linear characteristic is set in C00006 as motor control.

- ▶ The V/f characteristic control (VFCplus) is an operating mode for standard frequency inverter applications based on a simple and robust control process which is suitable for the operation of machines with linear or square-law load torque characteristic (e.g. fans).
- ▶ The parameter settings have been set in advance in such a way that, if the drive controller and 50 Hz asynchronous machine match each other in terms of performance, the drive controller is immediately ready for operation without any further parameter setting work and the motor works satisfactorily.

**Tip!****Recommendations for the following application cases:**

- ▶ If the controller and motor differ greatly from each other in terms of performance: Set the I<sub>max</sub> limit (in motor mode) in C00022 to double the rated motor current.
- ▶ If a higher starting torque is required: In idle state of the motor, set the V<sub>min</sub> boost in C00016 in such a way that the rated motor current flows at a field frequency of  $f = 3$  Hz (display in C00058).
- ▶ For noise optimisation: As switching frequency in C00018, set the selection "3: 16 kHz var./drive-optimised".
- ▶ If a high torque is to be available at low speed and without a feedback: Select the "vector control (SLVC)" mode in C00006 as motor control.

### 6.4.2 Short overview of the parameters for quick commissioning

The keypad menu "Quick commissioning" provides access to all essential parameters to commission the drive/application "Speed actuating – drive" quickly and easily. When these parameters are set to suitable and sensible values, an error-free operation of the controller is possible.

- ▶ The "Terminals" submenu contains the parameters for a control via terminals.
- ▶ The "Keypad" submenu contains the parameters for a control via keypad.

Parameter	Keypad display	Info	Lenze setting		Available in the submenu	
			Value	Unit	"Terminals"	"Keypad"
C00002/1	Load Lenze setting	Load Lenze setting	0: Off / ready		✓	✓
C00007	Select control mode	Select control mode	10: Terminals 0		✓	✓
C00728/3	nMainSetValue_a	Main setpoint	0.00	%	-	✓
C00011	Appl.: Reference speed	Reference speed	1500	rpm	✓	✓
C00012	Accel. time - main setpoint	Acceleration time - main setpoint	2,000	s	✓	✓
C00013	Decel. time - main setpoint	Deceleration time - main setpoint	2,000	s	✓	✓
C00015	VFC: V/f base frequency	V/f base frequency	50.0	Hz	✓	✓
C00016	VFC: Vmin boost	Vmin boost	2.60	%	✓	✓
C00022	Imax (motor mode)	Current limit (in motor mode)	5.8	A	✓	✓
C00087	Rated motor speed	Rated motor speed	1320	rpm	✓	✓
C00089	Rated motor freq.	Rated motor frequency	50	Hz	✓	✓
C00039/1	Fixed setpoint 1	Fixed setpoint 1	40.00	%	✓	✓
C00039/2	Fixed setpoint 2	Fixed setpoint 2	60.00	%	✓	-
C00039/3	Fixed setpoint 3	Fixed setpoint 3	80.00	%	✓	-
C00727/3	bSetSpeedCcw	Change of direction of rotation	0		-	✓
C00727/4	bJogSpeed1	Selection of fixed setpoint 1	0		-	✓
<i>C00051</i>	<i>MCTRL: Act. speed val.</i>	Actual speed value	-	rpm	✓	✓
<i>C00054</i>	<i>Motor curr.</i>	Current motor current	-	A	✓	✓

Display codes are shown in *italics*.

## 6.5 Setting with the diagnosis terminal (keypad)

The controller can also be set and controlled with the diagnosis terminal. The diagnosis terminal consists of a molded recess, connecting cable and the keypad which cannot be directly plugged onto the controller. Descriptions for the keypad can be done with the diagnosis terminal.

When the diagnosis terminal is connected, a preselected parameter is displayed after initialisation. In the Lenze setting, the actual speed value (C00051) is displayed. The preselected parameter can be changed (C00466).

**"SET" mode**

The right softkey "SET" serves to change from the display mode to the SET mode. In the SET mode, the speed setpoint can be changed and the controller can be enabled/inhibited (RFR/run). The SET mode can be quit with the right softkey "DISP". The change of the modes must always be confirmed with the right softkey "OK".

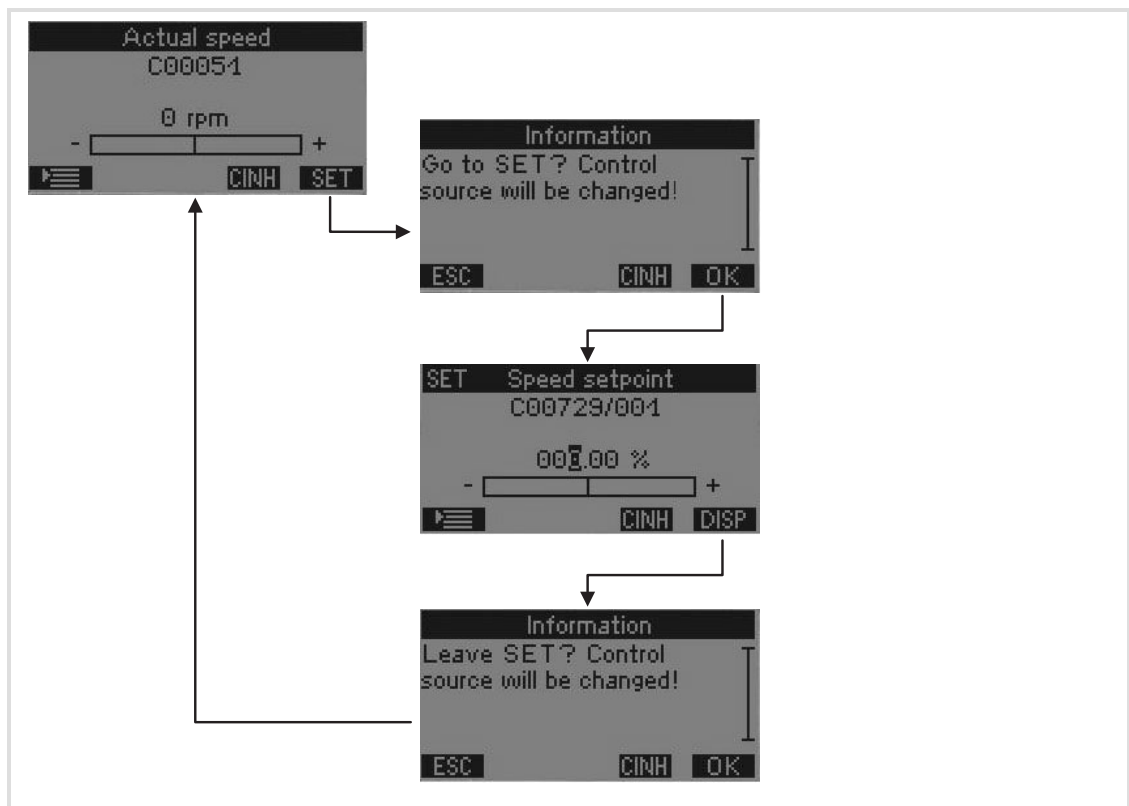

## 6.6 Diagnostics

### 6.6.1 Drive diagnostics via the integrated display

On the top side of the Drive Unit, a green/red LED display indicates the respective operating status of the controller. The LED shines brightly through the transparent cap.

LED status display		
Description	green	red
Mains off	off	off
Switch-on phase (initialisation) (shining yellow)	on	on
Operation or motor data identification	on	off
Controller inhibited (RFR)	blinking	
Safety function active (Safe torque off)	flashing	
Controller is ready (initialisation completed)	flashing twice	flashes every 3 s
Operation with warning active	on blinking flashing twice	
Quick switch-off active	on	flashing
System error	off	on
Error		blinking
Message is active		flashing

	LED flashes once approx. every 3 seconds (slow flash)
	LED flashes once approx. every 1.25 seconds (flash)
	LED flashes twice approx. every 1.25 seconds (double flash)
	LED blinks every second
	LED is permanently on

### 6.6.2 Diagnostic codes

Important codes for diagnostics

In addition to the keypad, also use the LEDs on the front of the controller for drive diagnostics:

- ▶ Two LEDs indicate the device status (DRIVE READY and DRIVE ERROR)
- ▶ Two LEDs indicate the bus status (CAN-RUN and CAN-ERROR)

The LEDs for the bus status are less important during quick commissioning.



#### Tip!

The handling of the keypad X401 or the diagnosis terminal X401 is described in the operating instructions. The instructions are supplied with the keypad and are also included in electronic form on the product CD "L-force Inverter Drives 8400".

**DC injection brake DCB**

To decelerate small masses, the "DC injection brake DCB" function can be parameterised. DC-injection braking enables a quick deceleration of the drive to standstill without the need for an external brake resistor.

- ▶ Code C00036 can be used to select the braking current.
- ▶ The maximum braking torque to be realised by the DC braking current amounts to approx. 20 ... 30 % of the rated motor torque. It is lower compared to braking action in generator mode with external brake resistor.
- ▶ Automatic DC-injection braking (Auto-DCB) improves the starting performance of the motor when the operation mode without speed feedback is used.

Further information on the relevant parameters can be obtained from the software manual.

## 7.2 Braking operation with brake resistor

To decelerate greater moments of inertia or with a longer operation in generator mode, a brake resistor is required. It converts braking energy into heat.

The brake resistor is connected if the DC-bus voltage exceeds the switching threshold. This prevents the controller from setting pulse inhibit through the "Overvoltage" fault and the drive from coasting. The brake resistor serves to control the braking process at any time.

Options with 8400 motec:

1. There is no internal brake resistor integrated in the device. Braking energy cannot be converted into heat.
2. An internal brake resistor can optionally be attached from the corresponding accessories (📖 112). This enables the conversion of small amounts of braking energy into heat, according to the technical data.
3. An external brake resistor can optionally be attached from the accessories (📖 113). This enables the conversion of braking energy into heat, according to the technical data.

### 7.2.1 Selection of the brake resistors

The recommended Lenze brake resistors are adapted to the corresponding controller (with regard to 150 % of regenerative power). They are suitable for most of the applications.

For special applications, e.g. centrifuges, the brake resistor must meet the following criteria:

Brake resistor Criterion	Application	
	With active load	With passive load
Continuous braking power [W]	$\geq P_{\max} \cdot \eta_e \cdot \eta_m \cdot \frac{t_1}{t_{\text{zykl}}}$	$\geq \frac{P_{\max} \cdot \eta_e \cdot \eta_m}{2} \cdot \frac{t_1}{t_{\text{zykl}}}$
Heat quantity [Ws]	$\geq P_{\max} \cdot \eta_e \cdot \eta_m \cdot t_1$	$\geq \frac{P_{\max} \cdot \eta_e \cdot \eta_m}{2} \cdot t_1$
Resistance [ $\Omega$ ]	$R_{\min} \leq R \leq \frac{U_{\text{DC}}^2}{P_{\max} \cdot \eta_e \cdot \eta_m}$	

Active load	Can start to move independent of the drive (e.g. unwinder)
Passive load	Can stop independent of the drive (e.g. horizontal travelling drives, centrifuges, fans)
$V_{\text{DC}}$ [V]	Switching threshold of brake chopper (8400 motec = 783 V)
$P_{\max}$ [W]	Maximum occurring braking power determined by the application
$\eta_e$	Electrical efficiency (controller + motor) Guide value: 0.54 (0.25 kW) ... 0.85 (11 kW)
$\eta_m$	Mechanical efficiency (gearbox, machine)
$t_1$ [s]	Braking time
$t_{\text{cycl}}$ [s]	Cycle time = time between two successive braking processes (= $t_1$ + dead time)
$R_{\min}$ [ $\Omega$ ]	Minimum permissible brake resistance (see rated data of the integrated brake chopper)

**7.2.2 Wiring of brake resistor****Danger!****Hazardous electrical voltage**

During operation of the standard device and **up to 3 minutes after power-off** hazardous electrical voltages may occur at the terminals of the brake resistor.

**Possible consequences:**

- ▶ Death or severe injuries when touching the terminals.

**Protective measures:**

- ▶ Disconnect the standard device from the mains before working on the brake resistor.
- ▶ Check all power terminals for isolation from supply.
- ▶ Select the mounting location so that the operating conditions mentioned in the mounting instructions for the brake resistor are permanently guaranteed.

**Danger!****Hot surface**

The brake resistor may get very hot. (For temperatures see the mounting instructions for the brake resistor.)

**Possible consequences:**

- ▶ Severe burns when touching the brake resistor.
- ▶ Fire or smouldering fire if flammable material is placed near the brake resistor or may get to it.

**Protective measures:**

- ▶ Before working on the brake resistor, check its surface temperature.
- ▶ Select the mounting location so that the operating conditions mentioned in the mounting instructions for the brake resistor are permanently guaranteed.
- ▶ Protect the mounting location through fire prevention.

Protect the brake resistor and controller against destruction caused by overload:

- ▶ Establish a safety shutdown using the thermostat of the brake resistor to disconnect the controller from the mains.

Connecting cable version

- ▶ up to 0.5 m: twisted and unshielded
- ▶ from 0.5 to 5 m: shielded
  - Use shielded cables to meet the EMC requirements.



## Wiring principle

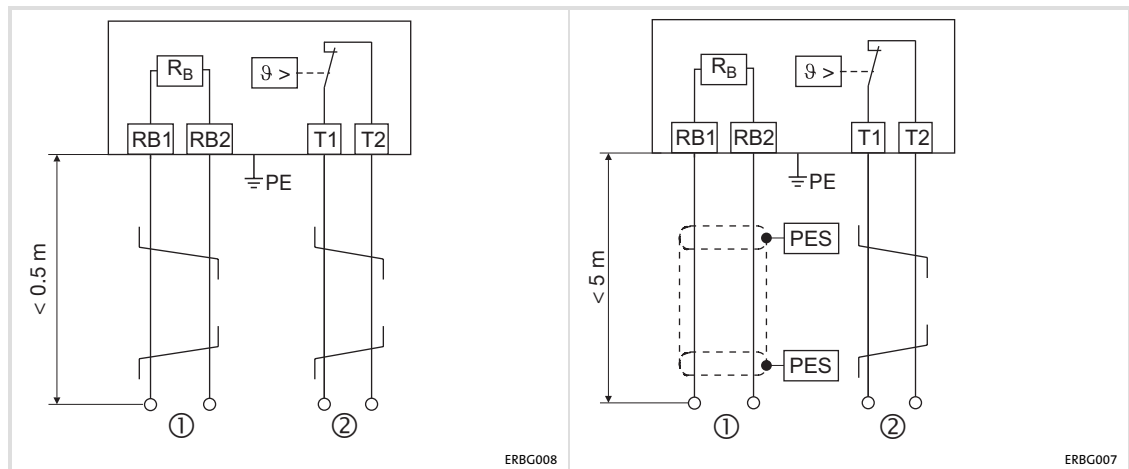

Fig. 7-1 Wiring of a brake resistor to the controller

PES	HF-shield termination by PE connection via shield clamp
Rb1, Rb2	Terminals of the brake resistor
①	Supply cable to the controller
T1, T2	Terminals temperature monitoring of the brake resistor (thermal contact/NC contact)
②	Supply cable for evaluation of temperature monitoring (to be integrated e.g. into the latch circuit of the mains contactor of the supply)

The brake resistor is thermally stressed due to converted braking power and may be thermally destroyed as a consequence of excessive braking power.

To avoid thermal overload of the brake resistor:

- ▶ set additional parameters in the »Engineer«

or

- ▶ implement external wiring using a temperature contact on the brake resistor (e.g. interrupted supply and activation of the mechanical brakes).

To protect the brake resistor:

- ▶ use the monitoring of the  $I^2 \cdot t$  utilisation of the controller which is proportional to the converted braking power.

## Braking operation

Braking operation with brake resistor  
Wiring of brake resistor

### Evaluation of the thermal contact via digital input

The integration of the thermal contact for monitoring the brake resistor can be implemented via digital input. Use a Lenze system cable. The response to the input signal must be parameterised using the »Engineer«.

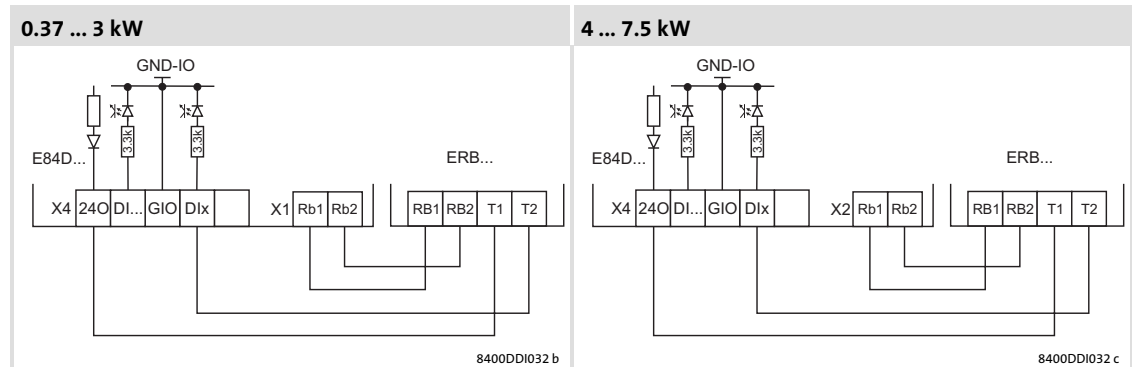

E84D...  
X4/DIx  
X1/Rb1,Rb2  
X2/Rb1,Rb2  
ERB...

8400 motec  
free digital input  
Connection of the brake resistor for devices 0.37 ... 3 kW  
Connection of the brake resistor for devices 4 ... 7.5 kW  
Brake resistor

## 7.3 Operation with spring-applied brake

### 7.3.1 Introduction

Lenze three-phase AC motors and G-motion geared motors can be equipped with spring-applied brakes (motor holding brakes). 8400 motec controllers are provided with an integrated motor brake control.

#### Switching the brake

The voltage required for controlling the motor brake is generated in the controller, depending on the mains voltage value. The following motor brakes can be connected:

- ▶ With 400-V mains: Coil voltage 180 V DC
- ▶ With 480-V mains: Coil voltage 215 V DC

Optionally, the switching of the brake can be controlled in addition:

- ▶ Via an external control contact (e.g. PLC)
- ▶ Via a brake switch which is connected to one of the digital outputs of the controller. The digital output must be parameterised accordingly.

The software manual provides further information on the parameterisation and integrated brake management.

### 7.3.2 Wiring

The cable of the motor holding brake can be routed directly by means of a cable gland in parallel to the motor axis.

The motor holding brake is connected to BD1 (+) and BD2 (-).

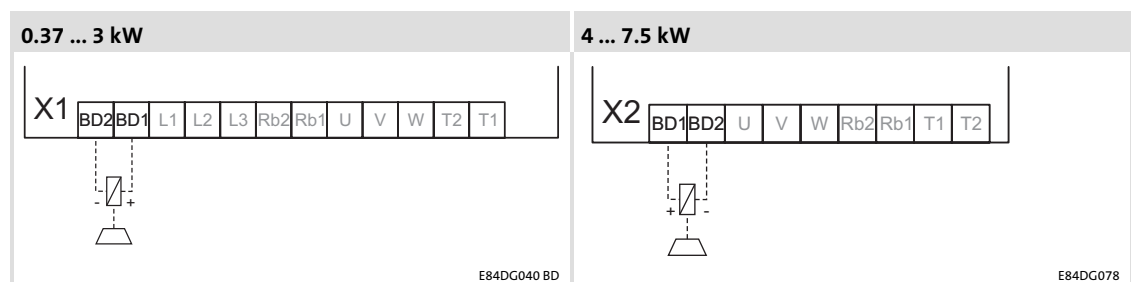

- |     |  |
|-----|--|
| X1  | Terminal in the Wiring Unit for devices 0.37 ... 3 kW    |
| X2  | Terminal in the Wiring Unit for devices 4 ... 7.5 kW     |
| BD1 | Connection of spring-applied brake +                     |
| BD2 | Connection of spring-applied brake -                     |
| ⊕   | HF-shield termination by large surface connection to PE. |
| ⊕   | Earthing (PE)  |

**8**      **Safety engineering**

**8.1**      **Introduction**

With increasing automation, protection of persons against hazardous movements is becoming more important. Functional safety describes the measures needed by means of electrical or electronic equipment to reduce or remove danger caused by failures.

During normal operation, safety equipment prevents people accessing hazardous areas. In certain operating modes, e.g. set-up mode, work needs to be carried out in hazardous areas. In these situations the machine operator must be protected by integrated drive and control measures.

Drive-based safety provides the conditions in the controls and drives to optimise the safety functions. Planning and installation expenditure is reduced. In comparison to the use of standard safety engineering, drive-based safety increases machine functionality and availability.

**Drive-based safety with Inverter Drives 8400**

Decentralised drives are frequency inverters that are not mounted locally like control cabinet devices but are directly attached to the application in the field. This product-specific feature results in high demands regarding robustness and class of protection.

The 8400 motec controllers are optionally available with an integrated safety system.

”Integrated safety” stands for application-oriented safety functions that are applicable on machines for the protection of persons.

The motion functions continue to be executed by the controller. The integrated safety system monitors the safe compliance with the limit values and provides the safe inputs and outputs. If limit values are exceeded, the integrated safety system starts control functions according to EN 60204-1 directly in the controller for the case of an error.

The safety functions are suitable for applications according to IEC 61508 to SIL 3 and achieve the performance level (PL)e according to EN ISO 13849-1. The requirements of the standard EN 954-1 valid until 30 November 2009 are met until control category 4.

## 8.2 Important notes

### Application as directed

The controllers that are equipped with safety engineering must not be modified by the user. This concerns the unauthorised exchange or removal of the safety engineering.



#### **Danger!**

##### **Danger to life through improper installation**

Improper installation of safety engineering systems can cause an uncontrolled starting action of the drives.

##### **Possible consequences:**

- ▶ Death or severe injuries

##### **Protective measures:**

- ▶ Safety engineering systems may only be installed and commissioned by qualified and skilled personnel.
- ▶ All control components (switches, relays, PLC, ...) and the control cabinet must comply with the requirements of ISO 138491 and ISO 13849-2. This includes i.a.:
  - Switches, relays with at least IP54 enclosure.
  - Control cabinet with at least IP54 enclosure.
  - Please refer to ISO 138491 and ISO 13849-2 for all further requirements.
- ▶ Wiring must be shielded.
- ▶ All safety relevant cables outside the control cabinet must be protected, e.g. by means of a cable duct:
  - Ensure that no short circuits can occur.
  - For further measures see EN ISO 13849-2.
- ▶ If an external force acts upon the drive axes, additional brakes are required. Please observe that hanging loads are subject to the force of gravity!



#### **Danger!**

When the "safe torque off" (STO) function is used, an "emergency switching-off" according to EN 60204 is not possible without additional measures. There is no electrical isolation, no service switch or repair switch between motor and controller!

"Emergency switching-off" requires an electrical isolation, e.g. by a central mains contactor!

**During operation**

After the installation is completed, the operator must check the wiring of the safety function.

The functional test must be repeated at regular intervals. The time intervals to be selected depend on the application, the entire system and the corresponding risk analysis. The inspection interval should not exceed one year.

**Residual hazards**

In case of a short-circuit of two power transistors a residual movement of the motor of up to  $180^\circ$ /number of pole pairs may occur! (Example: 4-pole motor  $\Rightarrow$  residual movement max.  $180^\circ/2 = 90^\circ$ )

This residual movement must be considered in the risk analysis, e.g. safe torque off for main spindle drives.

**8.2.1 Hazard and risk analysis**

This documentation can only accentuate the need for hazard analysis. The user of the integrated safety system must read up on standards and the legal situation:

Before the launch of a machine, the manufacturer of the machine must conduct a hazard analysis according to Machinery Directive 2006/42/EC to determine the hazards associated with the application of the machine. The Machinery Directive refers to three basic principles for the highest possible level of safety:

- ▶ Hazard elimination / minimisation by the construction itself.
- ▶ Required protective measures must be taken against hazards which cannot be eliminated.
- ▶ Existing residual hazards must be documented and the user must be informed of them.

Detailed information on the hazard analysis procedure is provided in the EN 1050, risk assessment principles. The results of the hazard analysis determine the category for safety-related control systems according to EN ISO 13849-1. Safety-oriented parts of the machine control must be compliant.

**8.2.2 Standards**

Safety regulations are confirmed by laws and other governmental guidelines and measures and the prevailing opinion among experts, e.g. by technical regulations.

The regulations and rules to be applied must be observed in accordance with the application.

### 8.3 Basics for safety sensors

#### Passive sensors

Passive sensors are two-channel switching elements with contacts. The connecting cables and the sensor function must be monitored.

The contacts must switch simultaneously (equivalently). Nevertheless, safety functions will be activated as soon as at least one channel is switched.

The switches must be wired according to the closed-circuit principle.

Examples of passive sensors:

- ▶ Door contact switch
- ▶ Emergency-off control units

#### Active sensors

Active sensors are units with 2-channel semiconductor outputs (OSSD outputs). With the integrated safety system of this device series, test pulses  $< 1$  ms for monitoring the outputs and cables are permissible. The maximally permissible connection capacity of the outputs is to be observed.

P/M-switching sensors switch the positive and negative cable or the signal and ground wire of a sensor signal.

The outputs have to switch simultaneously. Nevertheless, safety functions are triggered as soon as at least one channel is switched.

Examples of active sensors:

- ▶ Lightgrid
- ▶ Laser scanner
- ▶ Control systems

# 8 Safety engineering

Operating mode  
Introduction

## 8.4 Operating mode

### 8.4.1 Introduction

Due to safety option 10, the following safety functions can be used:

- ▶ Safe torque off (STO),  
formerly: safe standstill

If requested, the safe disconnection of the drive is achieved through:

- ▶ Directly connected active sensors
- ▶ Passive sensors connected to a safety switching device

The safety functions are suitable for applications according to IEC 61508 to SIL 3 and achieve a performance level (PL) e and the control category 4 according to EN ISO 13849-1.



### Danger!

If the request for the safety function is cancelled, the drive will restart automatically.

You must provide external measures which ensure that the drive only restarts after a confirmation (EN 60204).

### 8.4.2 Disconnecting paths

The transmission of the pulse width modulation is safely switched (off) by the safety unit. After this, the power drivers do not generate a rotating field. The motor is safely switched to torqueless operation (STO).

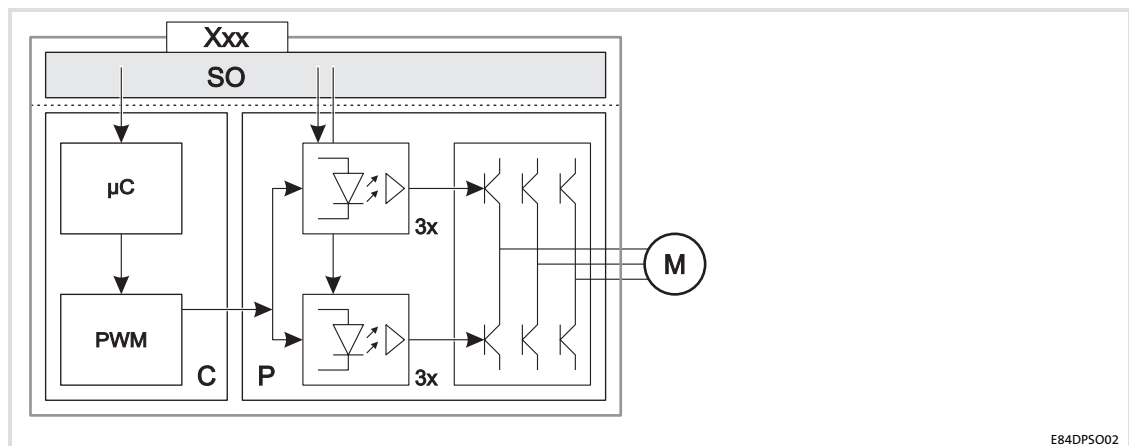

Fig. 8-1 Operating principle of safety unit

SO	Safety option 10
xxx	Control terminals of the safety system or safety bus
C	Control section
μC	Microcontroller
PWM	Pulse width modulation
P	Power section
M	Motor



### **8.4.3 Safety status**

When the controller is disconnected from the safety unit, the "Safe torque off" (STO) status is set (C00155 bit 10 = 1).

## 8.5

## Technical data

## Supply

The safe input and the output are isolated and designed for a low-voltage supply through a safely separated power supply unit (SELV/PELV) of 24 V DC. PM-switching input signals and test pulses  $\leq 1$  ms are permissible.

Active sensors are directly connected to X61.

Passive sensors are connected to X61 via a switching device. The switching device must comply with the required performance level of the application.

There is no monitoring for short circuits.

## Detailed features of the inputs and outputs of the safety unit

Terminal	Specification	[Unit]	min.	typ.	max.
SIA, SIB	Low signal	V	-3	0	5
	High signal	V	18	24	30
	Input capacitance at switch-off	nF		3	
	Input delay (tolerated test pulse)	ms			1
	Switch-off time (depending on the controller)	ms	2.5	4	
	Running time	ms		3	
	Input current SIA	mA		35	50
	Input current SIB	mA		25	50
	Input capacitance at switch-on	$\mu$ F		6	
GI	GND potential for SIA / SIB and for the unsafe signalling output				
240	Supply voltage through safely separated power supply unit (SELV/PELV)	V	18	24	30
DO	Low signal	V		0	0.8
	High signal	V	18	24	30
240, DO	Output current	A			0.2

## Truth table

Safe input / channel		Signalling output	Controller	
SIA	SIB		Description of the device status	Enable
0	0	1	"SafeTorqueOff" activated (safe torque off)	0
0	1	0	Fault scenario or impermissible status	0
1	0	0		0
1	1	0	Drive active or "ReadyToSwitchOn"	1

**Note!**

Safe inputs are designed with 2 channels (...A/...B). The channels must be controlled separately and simultaneously (in an equivalent manner).

The active control of only one channel indicates a faulty sensor system or an impermissible interconnection.

**Restriction of use**

The operation of an integrated safety system is **not** permissible in earthed phase mains.

## 8.6

### Electrical installation

X61 - connection of safety system "Safety Option 10"		
Pin	Connection	Description
<p style="text-align: right;">E84DG027</p>		Terminal strip, 5-pole
	SIA	Safe input, channel A
	SIB	Safe input, channel B
	GI	GND potential for SIA/SIB GND potential for the unsafe signalling output
	240	24 V voltage supply for the unsafe signalling output
	DO	Unsafe signalling output: "SafeTorqueOff" with a 2-channel request by SIA and SIB

#### X61

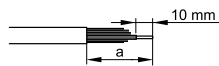

E84DG025

X61	a [mm]		[mm <sup>2</sup> ] [AWG]
Safety	55		0.5 ... 1.5 20 ... 16
			0.5 ... 1.0 20 ... 18
			0.5 20



#### Note!

The wiring connected for test purposes to the connections of the safety system must be removed (e.g. bridges SIA/SIB at 240).

## 8.7 Certification



### Tip!

The "TÜV Rheinland Group" certificate is available on the Internet under:  
<http://www.Lenze.com>

## 9 Accessories (overview)

### Adapter plates (accessories)

## 9 Accessories (overview)

### 9.1 Adapter plates (accessories)

For the mounting of the 8400 motec separated from the motor, a wall adapter is available.

► Wall adapter E84DZMAWE1

The wall adapter can be used in small spaces. Increased expenditure for installation (📖 73) due to a suitable motor cable must be considered. In addition, an installation according to EMC (structure of the C-typical drive system(📖 56)) must be considered.

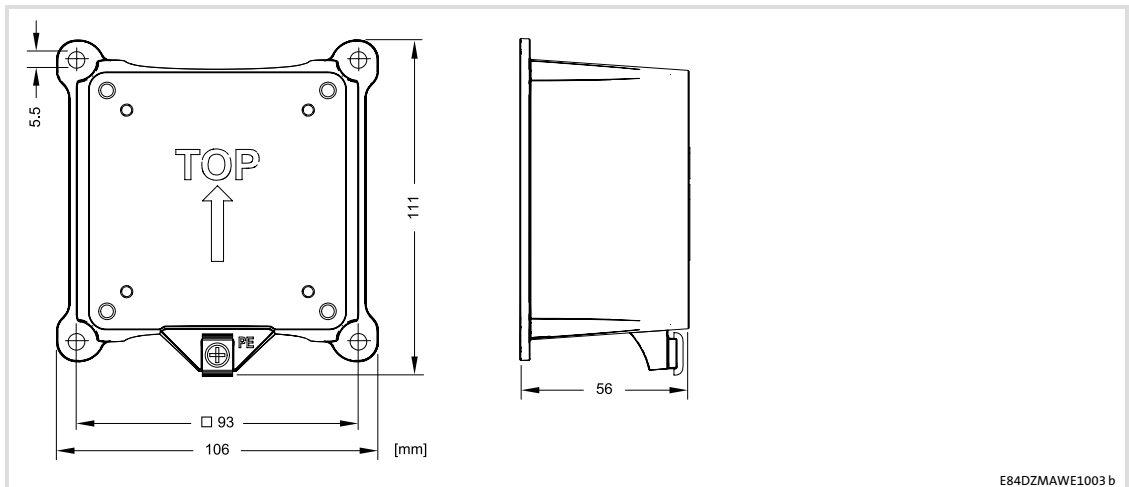
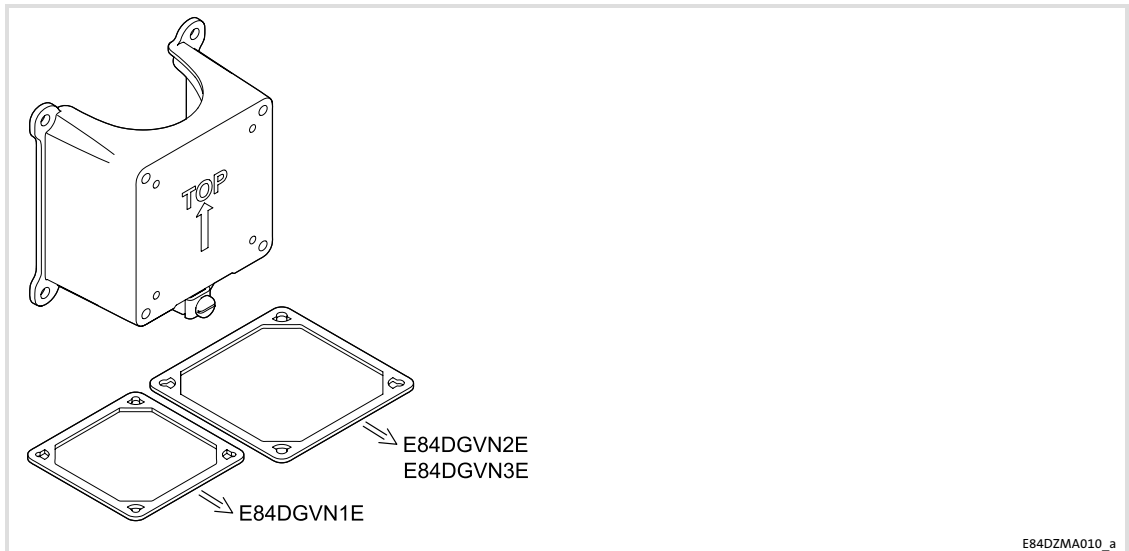

## 9.2 Plug connectors







By default, cables for the connection of the mains and the motor are led into the WU by means of cable glands. Alternatively, plug-in modules with prewired Q-plugs can be supplied for mounting on the right or the left.

For plug-in modules with a Q-plug, an M16 bore for an additional cable gland is available.

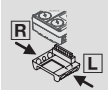
Plug-in modules with two Q-plugs are designed for a looping-through connection (daisy-chain). Like this it is possible to use a supply bus for the machine design.

In the case of wall mounting, the plug-in modules with a Q8-plug enable the motor connection as a plug&drive drive, in particular with Lenze system cables.

In the table the retrofittable plug-in modules are listed.

		X...	U <sub>max</sub> [V]	I <sub>max</sub> [A]		IP
E84DZEVBANP	L	X10: Q5	400 ~	16 ~	 ≤ E84DGDVB3024...	IP65
E84DZEVBANP	R					
E84DZEVBALFP	L	X10: Q5 X11: Q5	400 ~	16 ~	 ≤ E84DGDVB3024...	
E84DZEVBRFP	R					
E84DZEVBLPNP	L	X10: Q4/2	480 ~	32 ~		
E84DZEVBRPNP	R					
E84DZEVBLPRP	L	X10: Q4/2 X11: Q4/2	24 =	10 =		
E84DZEVBRPRP	R					
E84DZEVBLGNP	L	X21: Q8	480 ~	-		
E84DZEVBRGNP	R					

# 9 Accessories (overview)

## Internal brake resistors

### 9.3 Internal brake resistors

Product key		Rated data - brake resistor		
Controller	Brake resistor	Resistor R [ $\Omega$ ]	Continuous power P [W]	Heat quantity Q <sub>B</sub> [kW <sub>s</sub> ]
E84DGDVB3714 E84DGDVB5514 E84DGDVB7514 E84DGDVB1124 E84DGDVB1524	E84DZEW220R	220	15	0.6
E84DGDVB2224 E84DGDVB3024	E84DZEW100R	100	15	0.6
E84DGDVB4024 E84DGDVB5524 E84DGDVB7524	E84DZEW47R0	47	15	0.6

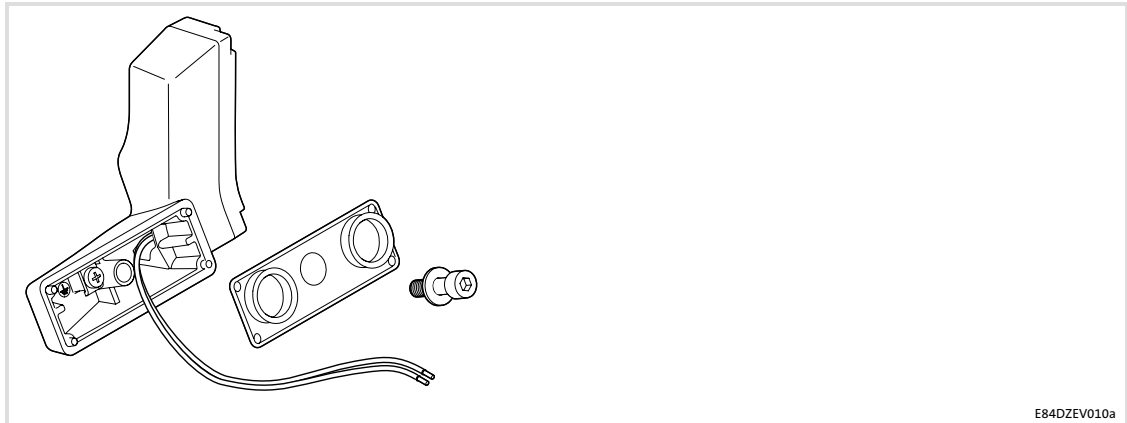



9.4 External brake resistors

Product key		Rated data - brake resistor		
Controller	Brake resistor	Resistor R [ $\Omega$ ]	Continuous power P [W]	Heat quantity Q <sub>B</sub> [kW <sub>s</sub> ]
E84DGDVB3714	- (  MA ERBS470R)	$\geq 180$	600	-
E84DGDVB5514			800	-
E84DGDVB7514			1050	-
E84DGDVB1124			1400	-
E84DGDVB1524			1800	-
E84DGDVB2224	-	$\geq 100$	2600	-
E84DGDVB3024			3600	-
E84DGDVB4024	-	$\geq 47$	4800	-
E84DGDVB5524			6600	-
E84DGDVB7524			9000	-

## 9 Accessories (overview)

Communication modules

CANopen

### 9.5 Communication modules

”Communication Units” are the communication modules for the 8400 motec controller.

The controller must at least be provided with the CU ”NO BUS”, E84DGFCNNNx. This module offers a minimum control via two digital inputs.

In order to enable a fieldbus communication, one of the following CU variants must be used.

#### 9.5.1 CANopen

For fieldbus communication via CANopen, the Communication Unit is available in two versions:

- ▶ E84DGFCxNX (without safety system)
- ▶ E84DGFCxJX (with safety system, additional analog input, and switching contact)

Detailed information on the 8400 motec with CANopen can be found in the EDS84DMOTCAN communication manual.

#### 9.5.2 PROFIBUS

For fieldbus communication via PROFIBUS, the Communication Unit is available in two versions:

- ▶ E84DGFCPxNX (without safety system)
- ▶ E84DGFCPxJX (with safety system, additional analog input, and switching contact)

Detailed information on the 8400 motec with PROFIBUS can be found in the EDS84DMOTPBUS communication manual.

#### 9.5.3 AS interface

For fieldbus communication via AS interface, the Communication Unit is available in two versions:

- ▶ E84DGFCAxNX (without safety system)
- ▶ E84DGFCAxJX (with safety system, additional analog input, and switching contact)

Detailed information on the 8400 motec with AS interface can be found in the EDS84DMOTASI communication manual.

#### 9.5.4 PROFINET

For fieldbus communication via PROFINET, the Communication Unit is available in two versions:

- ▶ E84DGFCRxNX (without safety system)
- ▶ E84DGFCRxJX (with safety system, additional analog input and switching contact)

Detailed information on the 8400 motec with PROFINET can be found in the EDS84DMOTPNET communication manual.

#### 9.5.5 EtherCAT

For fieldbus communication via EtherCAT, the Communication Unit is available in two versions:

- ▶ E84DGFACTxNX (without safety system)
- ▶ E84DGFACTxJX (with safety system, additional analog input and switching contact)

Detailed information on the 8400 motec with EtherCAT can be found in the EDS84DMOTECAT communication manual.

#### 9.5.6 EtherNet/IP

For fieldbus communication via EtherNet/IP, the Communication Unit is available in two versions:

- ▶ E84DGFCGxNX (without safety system)
- ▶ E84DGFCGxJX (with safety system, additional analog input and switching contact)

Detailed information on the 8400 motec with EtherNet/IP can be found in the EDS84AYCEO communication manual.

#### 9.6 Keypad

Checking or changing parameters by experienced users can be executed by means of a keypad X401, diagnosis terminal version.

- ▶ Diagnosis terminal X401, EZAEBK2003

The diagnosis terminal can be connected to the diagnostics interface X70 on the top of the 8400 motec.

Chapters 6.3 - 6.5 describe the handling and setting using a keypad for 8400 motec.

Further information on the keypad can be found in the instructions supplied with the device.

## 9.7 Safety engineering

8400 motec controllers can optionally be provided with integrated safety engineering. This requires an extended Communication Unit.

The version provided with safety engineering is clearly designated in the E84DGFCxxJx type key.

Detailed information on integrated safety can be found in the chapter "Safety engineering" ( 100).

**10**      **Appendix**

**10.1**      **Total index**

**0 ... 9**

**8400 motec Set, motec Set, 24**

**A**

**Accessories, 110**

- Brake resistor, 95

**Ambient conditions**

- climatic, 28

- mechanical, 28

**Analog input, 50**

**B**

**Brake resistor**

- Selection, 95

- Wiring, 96

**Braking, 94**

**Braking operation, 94**

- DC injection brake DCB, 94

- with brake resistor, 95

- without additional measures, 94

**C**

**Cable**

- For control connections, 58

- for the motor connection, 57

**Cables**

- cross-sections, 34, 36, 38

- fuses, 34, 36, 38

**CANopen, 114**

**Commissioning, 74**

- per keypad, overview, 87

**Communication connection, 51**

**Communication modules, 114**

**Communication Unit, 23**

**Communication, connection, 51**

**Control cable, 58**

**Control terminals, 46**

**D**

**Definition of notes used, 11**

**Definitions, Terms, 10**

**Device protection, 18, 55**

**Diagnostic codes, 93**

**Digital inputs, 48**

**Digital output, 50**

**Dimensions for wall mounting, 53**

**Disconnecting paths, 104**

**Disposal, 14**

**Drive Unit, 23**

- settings, 70

**E**

**Electrical installation, 61, 108**

- communication connection, 51

- wiring of control connections, 62

**EMC, what to do in case of interferences, 59**

**EN 61000-3-2, 29**

**Enclosure, 27**

**F**

**Fuses, 34, 36, 38**

- operation with rated power, 400 V (UL), 34, 38

**G**

**General configuration, 77**

**H**

**Harmonic currents, limitation according to EN 61000-3-2, 29**

**Hazard analysis, 102**

**I**

**Identification, 21**

**Installation, 54**

- electrical, 61, 108

- mechanical, 60

**Interferences, eliminating EMC interferences, 59**

**Introduction, 104**

**IT system, 72**

- measures, 72

## K

Keypad, 116

## M

Mains current, 33 , 35 , 37

Mechanical installation, 60

Monitoring, Of the motor temperature, 45

Motor, connection, 45

Motor cable, 57

- length, 28

Motor power, typical, 33 , 35 , 37

Motor protection, 18

Motor temperature, monitoring, 45

Mounting place, 28

Mounting position, 28

## N

Nameplate, 21

Noise emission, 29

Noise immunity, 29

Notes, definition, 11

## O

Operating conditions, ambient conditions

- climatic, 28

- mechanical, 28

Operation, Overcurrent, 40

Output currents, Switching frequency-dependent, 36

Output power, 33 , 35 , 37

Output voltage, maximum, 31

Output voltage , 31

Overspeeds, 18

Overview

- Accessories, 110

- control terminals, 25

- terminals, 42

## P

Pollution, 28

Power system, 28

Power terminals, 44

Product description, 19

Protection of persons, 18

Protective insulation of control circuits, 27

Protective measures, 27

## Q

Quick commissioning, with keypad control, 87

## R

Rated data, Operation at increased rated power, 400 V mains, 35

Residual hazards, 18 , 102

Risk analysis, 102

## S

Safety, safety engineering, 100

Safety engineering, 100

- application as directed, 101

- Certification, 109

Safety functions, safety instructions, during operation, 102

Safety instructions, 12

- definition, 11

- during operation, 102

- layout, 11

Safety status, 105

Sensors, basics, 103

Site altitude, 28

Supply conditions, 28

- mains, 28

- motor, 28

Switching frequency reduction, 39

## T

Technical data, 26 , 106

- Operation at increased rated power, 400 V mains, 35

Terminals, 42

Terms, definitions, 10

Total index, 118

Type code, finding, 21

## U

Use in IT systems, 72

**V**

Validity, documentation, 7

**W**

Wall mounting, 73

Wiring, Brake resistor, 96

Wiring of control connections, 62

Wiring Unit, 22





© 06/2012



Lenze Drives GmbH  
Postfach 10 13 52  
D-31763 Hameln  
Germany



+49 (0)51 54 / 82-0



+49 (0)51 54 / 82-28 00



Lenze@Lenze.de



www.Lenze.com

Service

Lenze Service GmbH  
Breslauer Straße 3  
D-32699 Extertal  
Germany



00 80 00 / 24 4 68 77 (24 h helpline)



+49 (0)51 54 / 82-11 12



Service@Lenze.de

EDS84DG752 ■ 13410318 ■ EN ■ 4.0 ■ TD15

10 9 8 7 6 5 4 3 2 1