

SIEMENS

SIMATIC

ET 200S
Positioning

Operating Instructions

Preface

1

1STEP 5V

2

1PosUniversal

3

Legal information

Warning notice system

This manual contains notices you have to observe in order to ensure your personal safety, as well as to prevent damage to property. The notices referring to your personal safety are highlighted in the manual by a safety alert symbol, notices referring only to property damage have no safety alert symbol. These notices shown below are graded according to the degree of danger.

⚠ DANGER
indicates that death or severe personal injury will result if proper precautions are not taken.
⚠ WARNING
indicates that death or severe personal injury may result if proper precautions are not taken.
⚠ CAUTION
with a safety alert symbol, indicates that minor personal injury can result if proper precautions are not taken.
CAUTION
without a safety alert symbol, indicates that property damage can result if proper precautions are not taken.
NOTICE
indicates that an unintended result or situation can occur if the corresponding information is not taken into account.

If more than one degree of danger is present, the warning notice representing the highest degree of danger will be used. A notice warning of injury to persons with a safety alert symbol may also include a warning relating to property damage.

Qualified Personnel

The product/system described in this documentation may be operated only by **personnel qualified** for the specific task in accordance with the relevant documentation for the specific task, in particular its warning notices and safety instructions. Qualified personnel are those who, based on their training and experience, are capable of identifying risks and avoiding potential hazards when working with these products/systems.

Proper use of Siemens products

Note the following:

⚠ WARNING
Siemens products may only be used for the applications described in the catalog and in the relevant technical documentation. If products and components from other manufacturers are used, these must be recommended or approved by Siemens. Proper transport, storage, installation, assembly, commissioning, operation and maintenance are required to ensure that the products operate safely and without any problems. The permissible ambient conditions must be adhered to. The information in the relevant documentation must be observed.

Trademarks

All names identified by ® are registered trademarks of the Siemens AG. The remaining trademarks in this publication may be trademarks whose use by third parties for their own purposes could violate the rights of the owner.

Disclaimer of Liability

We have reviewed the contents of this publication to ensure consistency with the hardware and software described. Since variance cannot be precluded entirely, we cannot guarantee full consistency. However, the information in this publication is reviewed regularly and any necessary corrections are included in subsequent editions.

Table of contents

1	Preface	5
2	1STEP 5V	7
2.1	Product overview	7
2.2	Isochronous mode	9
2.3	Safety concept	10
2.4	Brief description of how to commission the 1STEP 5V	11
2.5	Terminal Assignment Diagram.....	16
2.6	Fundamentals of Positioning.....	18
2.6.1	Overview	18
2.6.2	Parameters and Settings	19
2.6.3	Traversal curve of the 1STEP 5V	20
2.6.4	Setting the Base Frequency.....	23
2.7	Functions of the 1STEP 5V.....	25
2.7.1	Overview	25
2.7.2	Search for Reference.....	26
2.7.3	Sequence of Execution of the Search for Reference	28
2.7.4	Set home position	31
2.7.5	Relative incremental mode (relative positioning)	32
2.7.6	Absolute incremental mode (absolute positioning)	33
2.7.7	Speed-control mode.....	34
2.7.8	Hold traversing job	36
2.7.9	Axis type and traversing range	38
2.7.10	Pulse Enable	40
2.7.11	Changing Parameters during Operation	41
2.7.12	Behavior of the Digital Inputs.....	42
2.7.13	Behavior at CPU-Master-STOP	44
2.8	Parameter assignment.....	45
2.9	Diagnostics.....	47
2.9.1	Diagnostics using the LED display	47
2.9.2	Error types.....	48
2.10	Feedback and Control Interface	49
2.10.1	Assignment of the Feedback and Control Interfaces.....	49
2.10.2	Traversing job, changing parameters and troubleshooting	56
2.11	Technical Specifications	59

3	1PosUniversal	61
3.1	Product overview.....	61
3.2	Safety concept	63
3.3	Brief Instructions on Commissioning the 1PosU.....	64
3.4	Terminal Assignment Diagram.....	70
3.5	Fundamentals of Controlled Positioning Using Rapid/Creep Feed	72
3.6	Functions of the 1PosU.....	75
3.6.1	Overview of the Functions.....	75
3.6.2	Axis, Drive and Encoder.....	79
3.6.3	Effect of the Directional Enables.....	82
3.6.4	Stop (MODE 0).....	83
3.6.5	Inching (MODE 1)	84
3.6.6	Reference Point Run (MODE 3)	86
3.6.7	Relative Positioning (MODE 4)	93
3.6.8	Absolute Positioning (MODE 5)	96
3.6.9	Canceling JOB Processing (JOB 0).....	99
3.6.10	Setting the Actual Value (JOB 1)	100
3.6.11	Moving the Encoder Range (JOB 2)	102
3.6.12	Changing the Switch-Off Difference (JOB 3)	104
3.6.13	Changing the Switchover Difference (JOB 4)	105
3.6.14	Evaluating the Reference Signal (JOB 9)	106
3.6.15	Latch Function (JOB 10)	108
3.6.16	Setting the Monitoring of the Direction of Rotation (JOB 11).....	110
3.6.17	Displaying Current Values (JOB 15).....	112
3.6.18	Error Detection/Diagnostics	114
3.7	CPU/Master Stop and RESET State.....	121
3.8	Parameter List.....	122
3.9	Diagnostics.....	129
3.9.1	Diagnostics using the LED display.....	129
3.9.2	Error Types of Channel-Specific Diagnostics	130
3.10	Control and Feedback Signals.....	131
3.11	Technical Specifications.....	134
	Index.....	139

Preface

How the Manual is Structured

This manual is supplementary to the *ET 200S Distributed I/O System* operating instructions.

The ET 200S Distributed I/O System

(<http://support.automation.siemens.com/WW/view/en/1144348>) operating instructions provide comprehensive information pertaining to the hardware configuration, installation, wiring, commissioning, diagnostics and technical specifications of the ET 200S distributed I/O system.

This manual provides a description of functions and the technical specifications of the ET 200S modules for positioning tasks: 1STEP 5V and 1PosUniversal.

How to Find Your Way Around

At the beginning of each section you will find a **Product Overview**, which lists the features and applications of the module described. You will also find the order number of the module and the name and release of the software required. For the current GSD file, go to:

- <http://www.automation.siemens.com/csi/gsd>

In each section you will then find a section with the heading **Brief Instructions on Commissioning** followed by the name of the relevant module. These brief instructions tell you in a series of short steps how to install and configure the module, how to integrate it in your use program, and how to test it in your user program.

Index

The index contains keywords that come up in the manual.

Standards and approvals

For information about standards and approvals, refer to the section "General technical specifications" in the ET 200S Distributed I/O System (<http://support.automation.siemens.com/WW/view/en/1144348>) operating instructions.

Recycling and disposal

The ET 200S 1STEP 5V and ET 200S 1PosUniversal modules can be recycled due to the non-toxic materials from which they are assembled. For environmentally sustainable recycling and disposal of your old device, contact a certified disposal service for electronic scrap.

Additional support

If you have any further questions about the use of products described in this manual and do not find the right answers here, contact your local Siemens representative (<http://www.siemens.com/automation/partner>):

A guide to the technical documentation for the various products and systems is available on the Internet:

- SIMATIC Guide manuals (<http://www.siemens.com/simatic-tech-doku-portal>)

The online catalog and online ordering systems are also available on the Internet:

- A&D Mall (<http://www.siemens.com/automation/mall>)

Training center

To help you get started with automation technology and systems, we offer a variety of courses. Contact your regional Training Center or the central Training Center in D-90327 Nuremberg, Germany.

- Internet: SITRAIN homepage (<http://www.sitrain.com>)

Technical Support

You can access technical support for all A&D projects via the following:

- Online support request form: (<http://www.siemens.com/automation/support-request>)

Service & Support on the Internet

In addition to our documentation, we offer a comprehensive online knowledge base on the Internet at:

Industry Automation and Drive Technologies - Homepage
(<http://www.siemens.com/automation/service&support>)

There you will find the following information, for example:

- The newsletter that provides up-to-date information on your products.
- The documents you need via our Search function in Service & Support.
- A forum for global information exchange by users and specialists.
- Your local partner for Automation and Drives.
- Information about on-site service, repairs, and spare parts. Much more can be found under "Services".

1STEP 5V

2.1 Product overview

Order number

6ES7 138-4DC01-0AB0

Description

The 1STEP 5V generates pulses for the power units of stepping motors. The number of pulses emitted determines the distance traversed. The pulse frequency determines the velocity. The change in the pulse frequency per time unit (second) is a measure for the acceleration or deceleration.

A stepping motor shaft turns by a certain angle with every pulse. During rapid pulse sequences, this stepping movement becomes a continuous turning motion.

Compatibility

The 1STEP 5V with the order number 6ES7 138-4DC01-0AB0 replaces the 1STEP 5V/204kHz with the order number 6ES7 138-4DC00-0AB0 compatibly.

Features

The 1STEP 5V has the following characteristic features:

- Modes:
 - Reference point approach
 - Relative incremental mode (relative positioning)
 - Absolute incremental mode (absolute positioning)
 - Speed-control mode
 - Set home position
- Can be used with STEP 7 Version V5.4 SP4 and later in non-isochronous and isochronous modes.
- Interface to commonly available stepping motor power units with differential signals for pulses and direction to RS 422
- Maximum output frequency 510 kHz
- Distance up to 16 777 215 (= $2^{24} - 1$) pulses
- Support of linear and modulo axes (rotary axes)
- Function and active level of the digital inputs can be configured

- Type of the feedback value can be set in the feedback interface (residual distance, position or frequency)
- Firmware update ¹⁾
- Identification data ¹⁾

¹⁾ The function is only available if the used interface module supports the required system services.

Configuration

In order to configure the 1STEP 5V use one of the following options

- STEP 7 as of Version V5.4 SP4 with the HSP 2068 (Hardware Support Package from the Internet)
- A GSD file (<http://www.automation.siemens.com/csi/gsd>)

Firmware update

In order to extend the functionality and eliminate errors, firmware updates can be downloaded to the 1STEP 5V using STEP 7 HW Config.

Note

When you launch the firmware update, the old firmware is deleted. If the firmware update is interrupted or canceled for any reason, the 1STEP 5V will no longer function correctly as a result. Restart the firmware update and wait until it has completed successfully.

Identification data

The following identification data are stored on the 1STEP 5V:

- Hardware version
- Firmware product version
- Serial number

For additional information, refer to the "Identification data" section in the ET 200S Distributed I/O System (<http://support.automation.siemens.com/WW/view/en/1144348>) operating instructions.

2.2 Isochronous mode

Note

For basic information on isochronous mode, refer to the Isochronous mode (<http://support.automation.siemens.com/WW/view/en/15218045>) function manual.

Hardware requirements

You will require the following for the 1STEP 5V in isochronous mode:

- A CPU that supports isochronous mode
- PROFIBUS master or PROFINET controller that supports the constant bus cycle time
- IM 151 that supports isochronous mode

Response of the 1STEP 5V

Depending on the system parameter assignment, the 1STEP 5V works in either non-isochronous or isochronous mode.

In isochronous mode

- Motion commands are started or stopped isochronously.
- The feedback interface is updated isochronously.
- All 8 bytes of the user data interface are consistent.

If a parameter assignment error occurs, the 1STEP 5V does not go into isochronous mode.

If isochronous mode fails due to faults or failure/delay of global control (GC), the 1STEP 5V returns to isochronous mode during the next cycle without an error response.

If isochronous mode fails, the user data interface is no longer updated synchronously.

2.3 Safety concept

Safety Measures

The following measures are vital to the safety of the system. Carry out the safety measures with particular care and adapt them to meet the requirements of the system.

 WARNING
<p>To prevent personal injury and damage to equipment please observe the following points:</p> <ul style="list-style-type: none"> • Install an emergency stop system in keeping with current technical standards (for example, European norms EN 60204, EN 418, etc.). • Make sure that no one has access to areas of the system with moving parts. • Install, for example, hardware limit switches for the end positions of the axes that switch off the power control system directly. • Install devices and take steps to protect motors and power electronics.

Setting up a positioning control

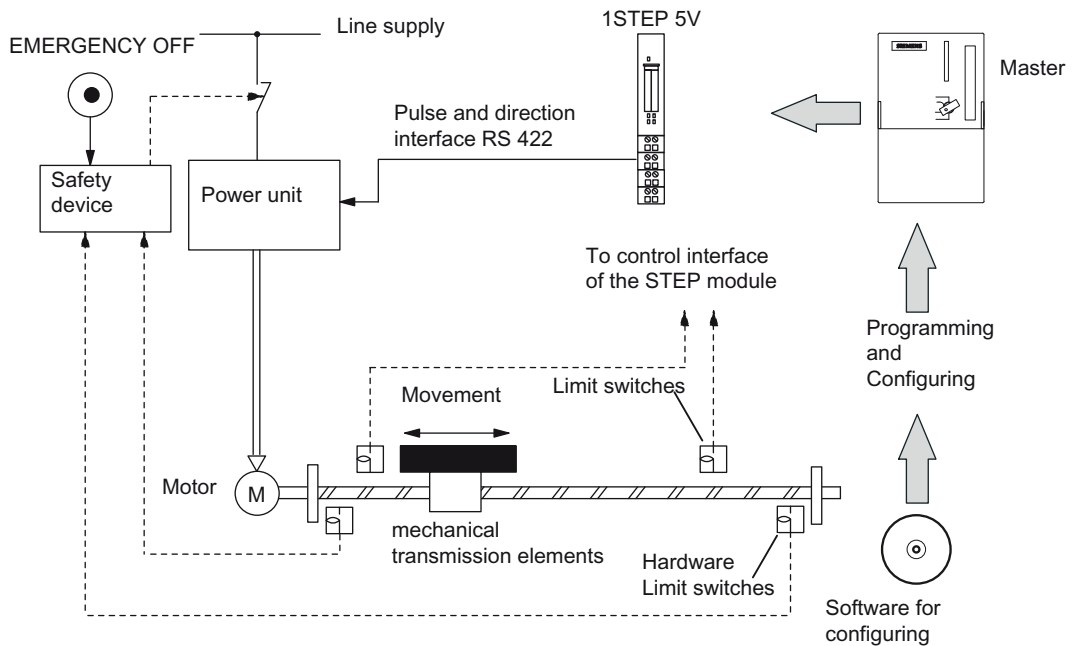

Figure 2-1 Design of a Positioning System with a Stepping Motor (Example)

1STEP 5V generates the control frequency and the directional signal for the power unit. The power unit processes the control signals and supplies the motor with power. The motor is connected directly or by means of mechanical transmission elements to the machine part that is to be moved.

2.4 Brief description of how to commission the 1STEP 5V

Introduction

The task of 1STEP 5V is to position a drive at certain predefined targets.

Using the example of an incremental run, it guides you to a functioning application in which you get to know and check a traversing job (both hardware and software) of your 1STEP 5V.

Note

Note that the power unit must process signals for pulses and direction in accordance with RS 422. Make sure you also adapt the wiring to the products you have chosen.

Prerequisites for the Example

The following prerequisites must be fulfilled:

- You must have put an ET 200S station on an S7 station with a DP master into operation.
- You must have the following:
 - A terminal module TM-E15x24-01 or TM-E15x26-A1
(order number 6ES7 193-4CBx0-0AA0 or 6ES7 193-4CAx0-0AA0)
 - A 1STEP 5V
(order number 6ES7 138-4DC01-0AB0)
 - A stepping motor with the corresponding power unit
 - The necessary wiring material

Installation, Wiring, and Fitting

1. Install and wire the TM-E15S24-01 terminal module (see the figure below).
2. Plug the 1STEP 5V into the terminal module. Detailed instructions are provided in the ET 200S Distributed I/O Device (<http://support.automation.siemens.com/WW/view/en/1144348>) operating instructions.

You can find out how to wire the power unit and the stepping motor in the relevant product manuals.

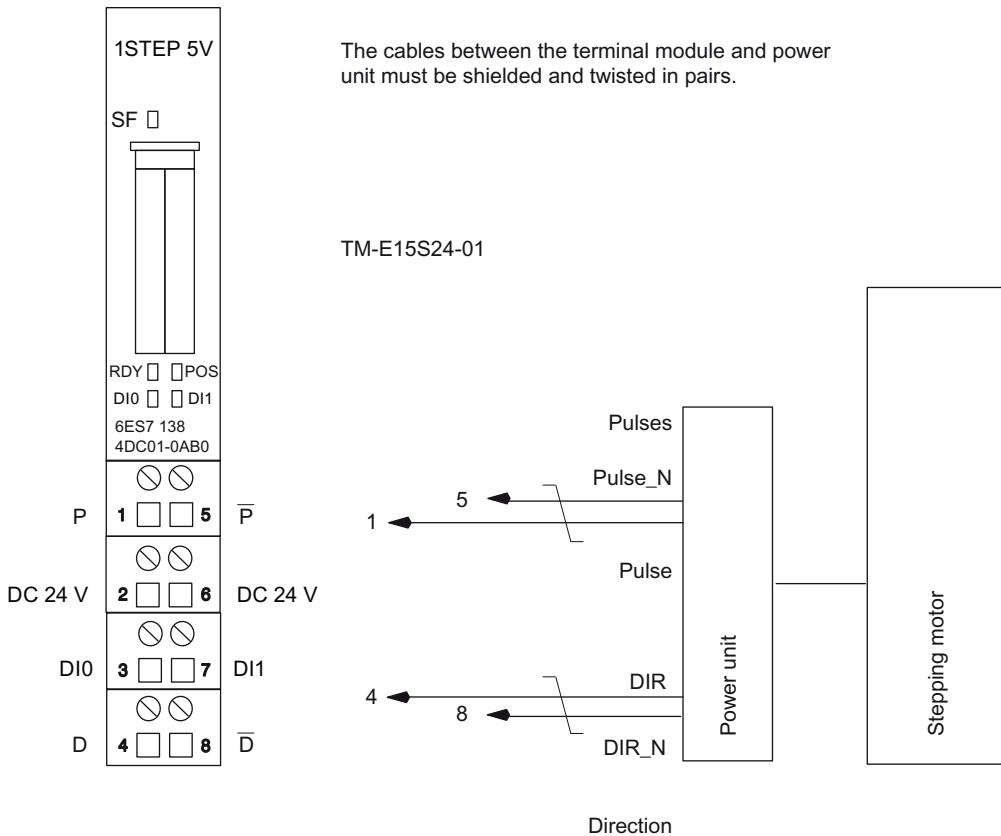

Figure 2-2 Terminal Assignment for the Example

Using HW Config to configure with STEP 7

You begin by adapting the hardware configuration to your existing ET 200S station.

1. Open the relevant project in SIMATIC Manager.
2. Open the HW Config configuration table in your project.
3. Select 1STEP in the hardware catalog. The number 6ES7 138-4DC01-0AB0 is displayed in the infotext. Drag the entry to the slot at which you have mounted your 1STEP 5V.
4. Double-click this number to open the DP Slave Properties dialog box.
5. On the Addresses tab, you will find the addresses of the slot to which you have dragged the 1STEP 5V. Make a note of these addresses for subsequent programming.
6. The Parameters tab contains the default settings for the 1STEP 5V. Set the "DI0 function" as an "external STOP". The "Input DI0" has to be set as a "NO contact".
7. Save and compile your configuration, and download the configuration in STOP mode of the CPU by choosing "PLC -> Download to Module".

Integrating the FC 101 Block into the User Program

Integrate the block FC101 in your user program, for example, in OB 1.

This block requires the DB1 data block with a length of 16 bytes. In the following example, the start is triggered by setting the memory bit 30.0 with the programming device.

WARNING

You may damage your system at the start of a run (4800 pulses forward). It may therefore be necessary to adjust the distance.

STL	Explanation
Block: FC101	
	//Initialize control interface
L L#4800	//Distance 4800 pulses
T DB1.DBD0	
L 1	//Multiplier 1 for output frequency
T DB1.DBB0	
L 0	//Delete limit switch etc.
T DB1.DBB5	
T DB1.DBW6	
SET	
S DB1.DBX5.2	//Set pulse enable DRV_EN
R DB1.DBX4.0	//Set relative incremental mode
R DB1.DBX4.1	//Set relative incremental mode

1STEP 5V

2.4 Brief description of how to commission the 1STEP 5V

STL	Explanation
R DB1.DBX4.2	//Set relative incremental mode
R DB1.DBX4.3	//Reserve bit = 0
R DB1.DBX4.5	//Delete backward start DIR_M
R DB1.DBX4.6	//Delete STOP
R DB1.DBX4.7	//Delete reduction factor R
L DB1.DBD0	//Write 8 bytes to the 1STEP 5V
T PQD 256	
L DB1.DBD4	
T PQD 260	
L PED 256	//Read 8 bytes from 1STEP 5V
T DB1.DBD8	
L PED 260	
T DB1.DBD12	
U M30.0	//Detect the edge on start initiation and set start DIR_P
UN DB1.DBX12.0	//if STS_JOB is deleted.
S DB1.DBX4.4	
U DB1.DBX12.0	//Wait for STS_JOB and
R DB1.DBX4.4	//Reset start DIR_P; the run begins
R M30.0	//Delete start initiation

Testing the Configuration

Start a "relative incremental mode" and monitor the associated feedback.

1. Using "Monitor/Modify Variables", check the residual distance and the status bits POS (positioning in operation) and STS_DRV_EN (pulse enable).
2. Select the "Block" folder in your project. Choose the "Insert > S7 Block > Variable Table" menu command to insert the VAT 1 variable table, and then confirm with OK.
3. Open the VAT 1 variable table, and enter the following variables in the "Address" column:
 - DB1.DBD8 (residual distance)
 - DB1.DBX13.7 (POS, positioning in operation)
 - DB1.DBX13.0 (STS_DRV_EN, pulse enable)
 - M30.0 Start by means of the programming device
4. Choose "PLC > File Connect To > Configured CPU" to switch to online.
5. Choose "Variable > Monitor" to switch to monitoring.
6. Switch the CPU to RUN mode.

Result

When you switch the CPU to RUN, the following results are obtained:

- The RDY LED lights up
- The POS status bit is deleted
- The STS_DRV_EN status bit is set

Start the run by setting memory bit 30.0 ("Variable > Modify >").

The following result is obtained during the run:

- The POS status bit is set (you can see this by monitoring the variable); that is, the POS LED lights up.
- The residual distance is continuously updated.
- The STS_DRV_EN status bit (pulse enable) is set.

The following result is obtained after the run has been completed:

- The POS status bit is deleted (you can see this by monitoring the variable); that is, the POS LED is no longer illuminated
- The residual distance is 0.
- The STS_DRV_EN status bit (pulse enable) is set.

2.5 Terminal Assignment Diagram

Wiring rules

The cables (terminals 1 and 5 and terminals 4 and 8) to the power unit must be shielded, twisted-pair cables. The shield must be supported at both ends. You use the shield contact element (Order Number: 6ES7 390-5AA00-0AA0).

Terminal assignment

You will find the terminal assignment for the 1STEP 5V in the table below.

Table 2- 1 Terminal assignment of the 1STEP 5V

View	Terminal assignment	Remarks
	<p>TM-E15S24-01 and 1STEP 5V</p>	<p>The cables between the terminal module and power unit must be shielded and twisted in pairs. P, /P and D, /D are signals to RS 422.</p>
	<p>TM-E15S26-A1 and 1STEP 5V</p>	<p>The cables between the terminal module and power unit must be shielded and twisted in pairs. P, /P and D, /D are signals to RS 422.</p>

2.6 Fundamentals of Positioning

2.6.1 Overview

Introduction

The following informs about how the individual components - the electronic module, the power unit, and the motor - affect each other.

Stepping motors

Stepping motors are used to position axes. They represent the simple and cost-effective solution for precision positioning tasks in wide performance ranges.

A stepping motor shaft turns by a certain angle with every pulse. During rapid pulse sequences, this stepping movement becomes a continuous turning motion.

Power unit for stepping motors

The power unit is the link between the 1STEP 5V and the stepping motor. The 1STEP 5V sends RS 422 differential signals for frequency and direction. These signals are converted in the power unit into motor currents that control the movements of the motor with a very high degree of precision.

1STEP 5V

The 1STEP 5V generates pulses and a directional signal for the power units of stepping motors. The number of pulses emitted determines the distance traversed. The pulse frequency determines the velocity. The change in the pulse frequency per time unit (second) is a measure for the acceleration or deceleration. 1STEP 5V is influenced by its parameters and settings.

2.6.2 Parameters and Settings

Required Information

To ensure optimum interplay between the individual components, you must provide the 1STEP 5V with information:

- **One time: during parameter configuration using your configuration software**
 - Base Frequency F_b (see section "Setting the Base Frequency (Page 25)")
 - Multiplier n for setting the start-stop frequency F_{ss} (see section "Traversal curve of the 1STEP 5V (Page 22)")
 - Multiplier i for setting the acceleration/delay (see section "Traversal curve of the 1STEP 5V (Page 22)")
 - Function and behavior of the digital inputs (see section "Behavior of the Digital Inputs (Page 42)")
 - Traversing range (see section "Axis type and traversing range (Page 38)")
- **In operation: movement of the motor by means of a traversing job in your user program**
 - Multiplier G for the velocity/output frequency F_a (see section "Traversal curve of the 1STEP 5V (Page 22)")
 - Reduction factor R (see section "Setting the Base Frequency (Page 25)")
 - Distance, position or frequency
 - Operating mode
 - Direction specification (traversing job) to the start
- **In operation: to adjust to different load conditions as a parameter assignment request in your user program**
 - Base Frequency F_b (see section "Setting the Base Frequency (Page 25)")
 - Multiplier n for setting the start-stop frequency F_{ss} (see section "Traversal curve of the 1STEP 5V (Page 22)")
 - Multiplier i for setting the acceleration/delay (see section "Traversal curve of the 1STEP 5V (Page 22)")

2.6.3 Traversal curve of the 1STEP 5V

Introduction

An incremental mode is carried out by the 1STEP 5V in accordance with the following traversal curve. The 1STEP 5V forms the fundamental parameters (start-stop frequency, output frequency, and acceleration/delay) of the traversal curve with a base frequency that you select (see section "Setting the Base Frequency (Page 25)").

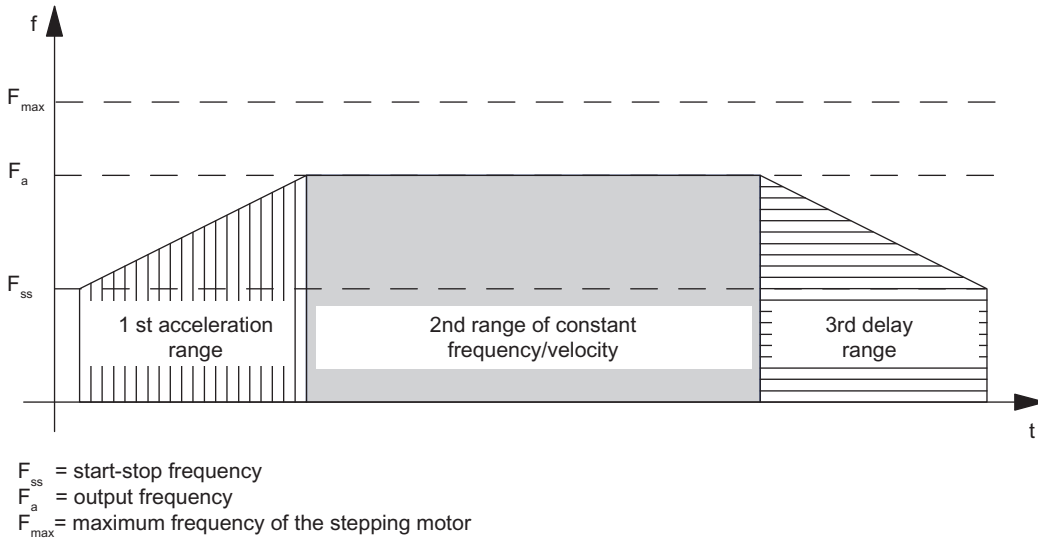

Figure 2-3 Traversal curve of the 1STEP 5V at incremental mode

Start-Stop Frequency F_{ss}

The start-stop frequency F_{ss} is the frequency to which the motor can be accelerated under load from a standstill.

The size of F_{ss} depends on the load inertia. The best way to work out the load inertia is by trial and error.

The start-stop frequency F_{ss} is simultaneously the minimum output frequency F_a needed to move the stepping motor.

Setting the Start-Stop Frequency F_{ss}

Through parameter assignment, the 1STEP 5V permits the start-stop frequency F_{ss} to be set in steps. To do so, select the multiplier n between 1 and 255, which is multiplied with the base frequency F_b . You can lower the start-stop frequency F_{ss} again with the reduction factor R (1 or 0.1) in the traversing job.

The start-stop frequency is calculated according to equation:

$$F_{ss} = F_b \times n \times R$$

Further information is available in the following table "Areas for start-stop frequency, starting frequency and acceleration".

Maximum frequency / velocity of the Axis F_{max}

When you choose a stepping motor, remember the following:

The maximum frequency/velocity is determined by your application. At this frequency, the motor must reach a torque high enough to move its load.

Note this does not mean the highest possible frequency that the motor or the power unit can tolerate.

You can work out the maximum frequency F_{max} with the corresponding characteristic curve.

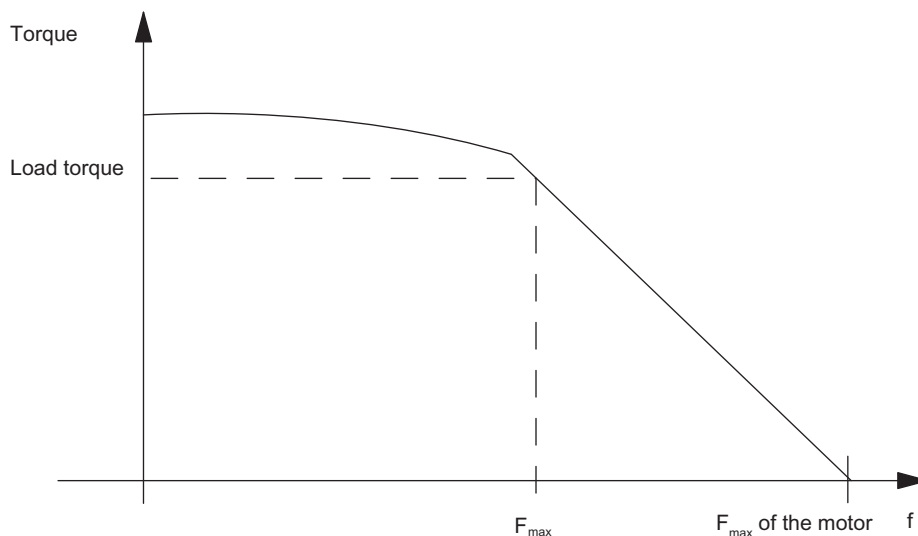

Figure 2-4 Torque Characteristic Curve of a Stepping Motor

Output frequency / velocity F_a

The output frequency can be set differently for each run.

When you select the output frequency, take the minimum pulse duration of your power unit into consideration (see the following table).

If the selected output frequency is lower than the set start-stop frequency F_{ss} , the 1STEP 5V output frequency is set to the start-stop frequency F_{ss} .

F_a must always be smaller than F_{max} .

Setting of the output frequency / Velocity F_a

The 1STEP 5V permits the output frequency F_a to be set in steps. To do so, select the multiplier G between 1 and 255, which is multiplied with the base frequency F_b . You can lower the output frequency F_a again with the reduction factor R (1 or 0.1) in the traversing job.

The output frequency is calculated according to the equation:

$$F_a = F_b \times G \times R$$

Further information is available in the following table "Areas for start-stop frequency, starting frequency and acceleration".

Acceleration / delay a

The maximum permitted acceleration / delay depends on the load to be moved.

The motor must reach a torque high enough to accelerate or delay the load without loss of step.

Depending on the application, you must also take into account additional criteria for setting the acceleration/delay, such as smooth starting and stopping.

Setting the acceleration / delay a

Through parameter assignment, the 1STEP 5V permits the acceleration / delay to be set in steps by means of the multiplier i .

During the acceleration phase, the frequency is increased continuously starting from the start-stop frequency F_{ss} until the output frequency F_a has been reached.

The time interval for the continuous increase in frequency can be set in steps. To do so you select a multiplier i between 1 and 255.

In the delay phase, the output frequency is reduced in the same way.

You can lower the acceleration / delay a again with the reduction factor R (1 or 0.1) in the traversing job.

The acceleration / deceleration is calculated according to the equation:

$$a = F_b \times R / (i \times 0.128 \text{ ms})$$

Further information is available in the following table "Areas for start-stop frequency, starting frequency and acceleration".

2.6.4 Setting the Base Frequency

Introduction

Through parameter assignment, the 1STEP 5V permits the base frequency to be set in steps.

The base frequency sets the range for the start-stop frequency, the output frequency, and the acceleration.

Procedure

1. Depending on the priority of your requirements select a suitable range either of the start-stop frequency F_{ss} and of the starting frequency F_a or of the acceleration a from the following table in accordance with the following criteria:
 - Range for the start-stop frequency F_{ss} ,
for example, for starting and stopping as soon as possible
 - Range for the output frequency F_a ,
for example, for a velocity setting that is as precise as possible
 - Range for the acceleration a ,
for example, for the fastest possible positioning operations
2. Use the table to determine the base frequency F_b .
To optimize the base frequency F_b , proceed as follows:
3. Check whether the other corresponding values meet your requirements. If necessary, select another base frequency F_b , which meets your requirements better.
4. Define the multipliers required to set the output frequency F_a , the acceleration/delay a , and the start-stop frequency F_{ss} .
5. Determine the corresponding reduction factor R from the table.

Table 2- 2 Ranges for the Start-Stop Frequency, Output Frequency, and Acceleration

Base frequency F_b : in Hz	Reduction factor R	Range Start-stop frequency F_{ss} Starting frequency F_a in Hz	Range Acceleration a in Hz/ms
		Equation: $F_{ss} = F_b \times n \times R$ $F_a = F_b \times G \times R$	Equation: $a = F_b \times R / (i \times 0.128 \text{ ms})$
4	0.1	0.4 ... 102	0.01 ... 3.13
8	0.1	0.8 ... 204	0.02 ... 6.25
20	0.1	2 ... 510	0.06 ... 15.6
4	1	4 ... 1020	0.12 ... 31.3
8	1	8 ... 2040	0.25 ... 62.5
20	1	20 ... 5100	0.61 ... 156
40	1	40 ... 10200	1.23 ... 313
80	1	80 ... 20400	2.45 ... 625
200	1	200 ... 51000	6.13 ... 1563
400	1	400 ... 102000	12.25 ... 3125
800	1	800 ... 204000	24.51 ... 6250
2000	1	2000 ... 510000	61.27 ... 15625

F_b = Base frequency
 F_{ss} = Start-Stop frequency
 F_a = Output frequency
a = Acceleration / delay
R = Reduction factor
n = Multiplier for setting the start-stop frequency in steps
G = Multiplier for setting the output frequency in steps
i = Multiplier for setting the acceleration / delay in steps

The minimum pulse duration results from the set starting frequency F_a and is calculated using the equation $T_{Pulse} = 1 / (2 \times F_a)$.

2.7 Functions of the 1STEP 5V

2.7.1 Overview

Introduction

The task of the 1STEP 5V is to position a drive on certain predefined targets (incremental modes) and to travel continuously with specifiable frequencies (speed-control mode).

The following functions are available to you to this purpose:

- Reference point approach: The axis is synchronized to a reference point
- Set home position: A value is assigned to the current position.
- Relative incremental mode (relative positioning): The axis is moved by a predefined distance.
- Absolute incremental mode (absolute positioning): The axis is traveled to a predefined position.
- Speed-control mode: The drive is moved with a speed that can be specified flexibly (pulse frequency).
- Hold traversing job
- Changing Parameters during Operation

For information on the functions, refer to the section Assignment of the Feedback and Control Interfaces (Page 49)

2.7.2 Search for Reference

Description of the function

The home position marks the point of reference of your drive system (reference cam) for the following traversing jobs. You can determine the home position by, for example, installing an initiator on the reference cam and connecting it to the DI1 digital input.

The 1STEP 5V ensures the reference point can be reproduced accurately in that it is always approached from the same direction. You can specify this direction by always starting the search for reference in the same direction.

Traversing job for reference point approach

The traversing job contains the following information:

- Multiplier G for the velocity/output frequency F_a
- Reduction factor R for the assigned parameters base frequency F_b
- Reference point position
- Mode = 1 for reference point approach
- Stop at reference cam (see section "Hold traversing job (Page 36)")
- Direction selection as Start (see section Assignment of the Feedback and Control Interfaces (Page 49))

Note

The 1STEP 5V checks the set position for limits (minimum 0 and maximum 16777215). The full-scale value can be configured.

Note

If you have configured the behavior of the digital input DI1 (7) as a "Reference switch and limit switch" (see section "Behavior of the Digital Inputs (Page 42)"), the 1STEP 5V automatically selects the starting direction toward the limit switch, irrespective of the direction specified in the traversing job.

Status bit SYNC

The SYNC status bit informs you that the axis has been synchronized, that is, after the correct reference point approach, this status bit is set and deleted during the run.

The SYNC status bit is deleted

- After parameter assignment of your ET 200S station
- After deletion of the pulse enable
- After a CPU-/Master-STOP

In these cases it is advisable to carry out a search for reference.

POS and POS_RCD status bits

While reference point approach is active, it is indicated by the set POS feedback bit.

On completion of a reference point approach, the set POS_RCD feedback bit indicates that the position has been reached.

If the reference point approach is interrupted, the POS_RCD feedback bit remains reset.

Residual distance, position, frequency

The residual distance reported is irrelevant during the reference point approach (see section "Assignment of the Feedback and Control Interfaces (Page 49)").

Note

In order for the 1STEP 5V to approach the home position with repeated precision, the period duration of the start-stop frequency has to be greater than the runtime of a single step from the 1STEP 5V to the stepping motor and via the reference cam back to 1STEP 5V. See also "Input delay of the digital inputs" in the section "Technical Specifications (Page 59)".

When stopping at the reference cam or at one of the limit switches during the acceleration phase, the 1STEP 5V continues to send pulses for a maximum of 50 ms at the frequency already reached before it starts braking. This avoids abrupt changes in frequency, which can lead to step losses.

2.7.3 Sequence of Execution of the Search for Reference

Steps of the Search for Reference

A search for reference consists of a maximum of three sections.

In the **first section** (1) and **second section** (2), the system ensures that the reference cam is found.

Both these sections are traversed at the defined output frequency F_a .

In the **third section** (3), the reference cam is approached with start-stop frequency F_{ss} in the selected direction up to the reference point \oplus with reproducible accuracy.

Note

The maximum number of output pulses of a section is the configured length of the traversing range minus 1.

Different Execution Sequences

Depending on the position \oplus at the start of the reference point approach, there are different execution patterns for the run (REF is the reference cam, which is wired to the DI1 digital input). The illustration applies to the forward starting direction (DIR_P).

Start before REF or at limit switch LIMIT_M

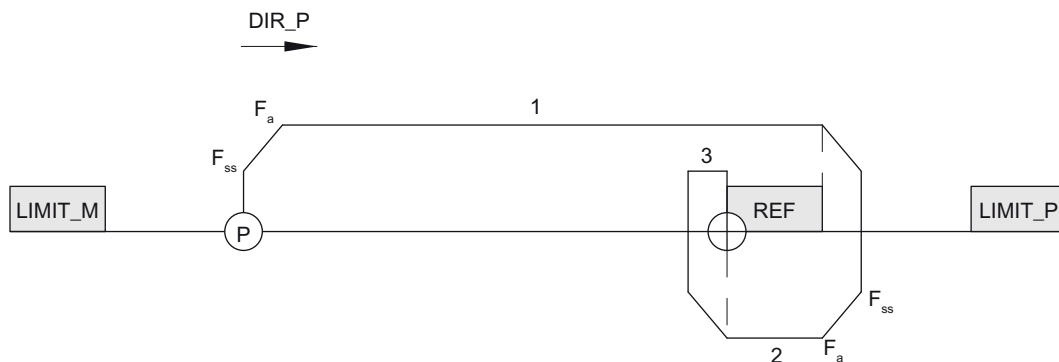

Figure 2-5 Reference point approach, start before REF

Start after REF

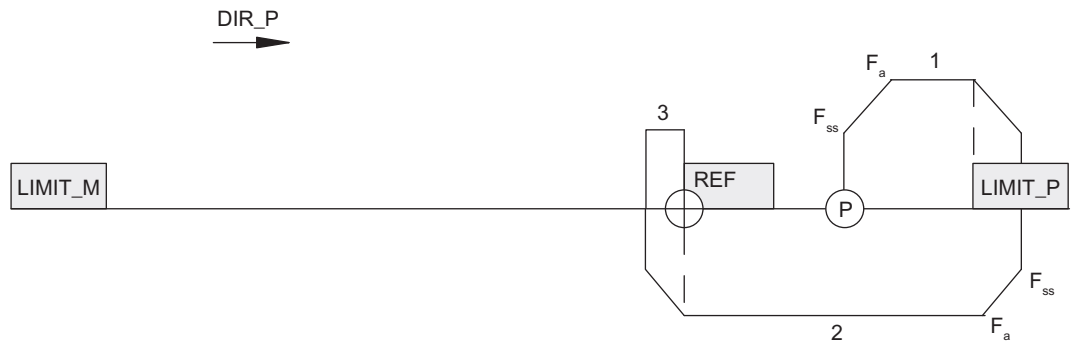

Figure 2-6 Reference point approach, start after REF

Start at REF

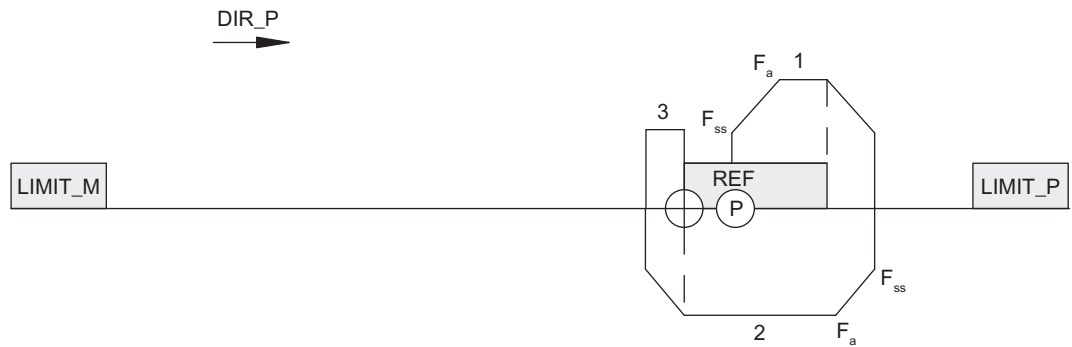

Figure 2-7 Reference point approach, start at REF

Start at the limit switch in start direction

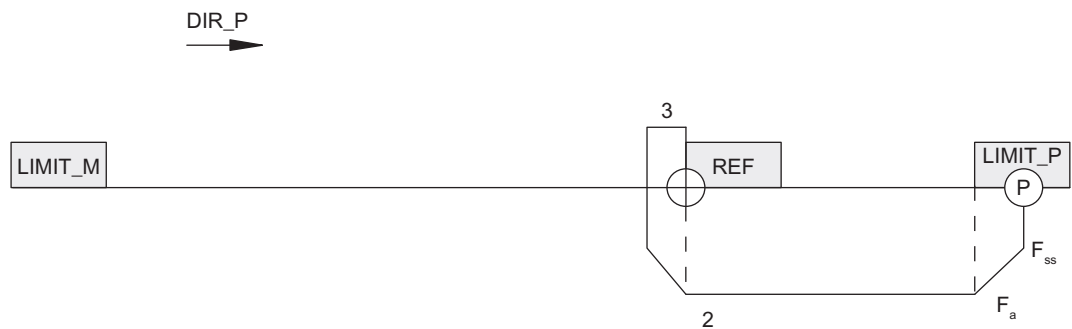

Figure 2-8 Reference point approach, start at limit switch in start direction

Response to defective reference cam with limit switch (interruption of traversing)

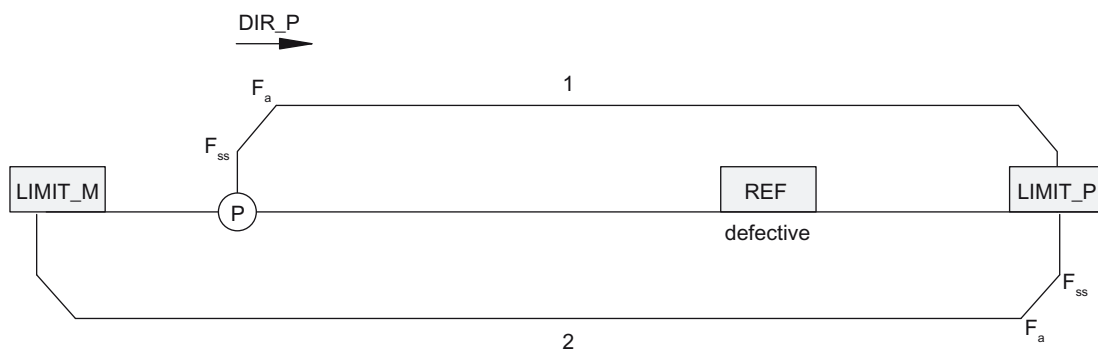

Figure 2-9 Defective reference cam, start before REF

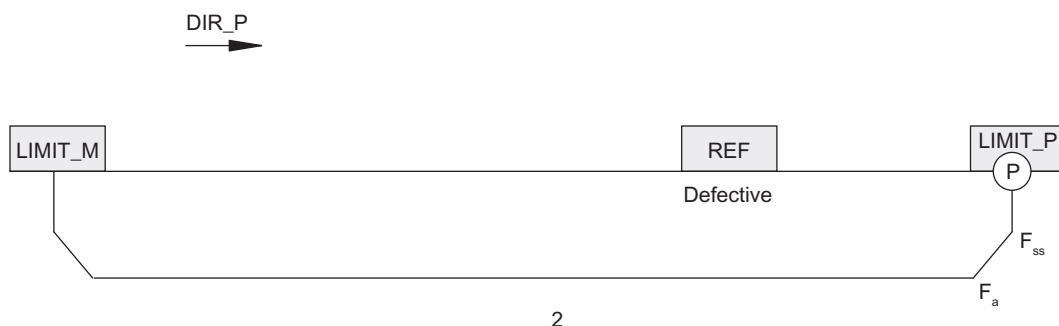

Figure 2-10 Defective reference cam, start at LIMIT_P

Behavior in the case of a constantly set reference cam without limit switch

At the end of the first section, after 16777215 pulses have been output, traversing is terminated with cleared SYNC and POS_RCD status bits.

Response to failure of the reference cam without limit switch

All three sections of traversing are executed, each with output of 16777215 pulses. Afterwards, the search is interrupted with cleared SYNC and POS_RCD status bits.

2.7.4 Set home position

Description of the function

The home position marks the reference point of your drive system which the subsequent absolute incremental modes and the position value in the feedback interface reference. You define the home position by specifying the absolute position value for the current position of the stepping motor.

Job for setting the home position

A job for setting the home position is a virtual job without traversing movement. It contains the following information:

- Position of the home position
- Mode = 4 for setting home position
- Any direction specification as start (see section "Assignment of the Feedback and Control Interfaces (Page 49)")

Note

The 1STEP 5V checks the set position for limits (minimum 0 and maximum 16777215). The full-scale value can be configured.

Feedback messages

Correct execution of the job is indicated by the set SYNC and POS_RCD feedback bits.

2.7.5 Relative incremental mode (relative positioning)

Description of the function

You can use the relative incremental mode to move the stepping motor a defined distance and thus approach a specified position.

You can determine the direction of traversing and the velocity at the start.

Traversing job for relative incremental mode

The traversing job contains the following information:

- Distance (number of pulses to be emitted)
- Multiplier G for the velocity/output frequency F_a
- Reduction factor R for the assigned parameters base frequency F_b
- Mode = 0 for incremental mode, relative
- Stop at reference cam (see section "Hold traversing job (Page 36)")
- Direction selection as start (see section "Assignment of the Feedback and Control Interfaces (Page 49)")

Note

The 1STEP 5V checks the specified distance for limits (minimum 1 and maximum 16777215 pulses). The distance to the limit switch is not checked by the 1STEP 5V. Traversing is stopped at the latest when the limit switch is reached.

Feedback messages

The POS_RCD feedback bit is reset at the beginning of incremental mode.

While the incremental mode is active, it is indicated by the set POS feedback bit.

After incremental mode has been correctly executed, the set POS_RCD feedback bit indicates that the position has been reached.

If the incremental mode is interrupted, the POS_RCD feedback bit remains reset. After incremental mode has been stopped, the distance still to be traversed is displayed if the feedback value is set to "Residual distance (see section "Assignment of the Feedback and Control Interfaces (Page 49)").

2.7.6 Absolute incremental mode (absolute positioning)

Description of the function

You can use the absolute mode to move the stepping motor to a defined position and thus approach a specified position.

The velocity is specified at the start. The direction and the distance of traversing are determined automatically by the 1STEP 5V on the basis of the starting position (actual position value). You can also specify the direction for a modulo axis.

Note

If you set Forward start and Backward start (DIR_P and DIR_M) simultaneously at a modulo axis, the 1STEP 5V then automatically selects the shortest distance to reach the target position (see section "Axis type and traversing range (Page 38)").

Traversing job for absolute incremental mode

The traversing job contains the following information:

- Target position
- Multiplier G for the velocity/output frequency F_a
- Reduction factor R for the assigned parameters base frequency F_b
- Mode = 2 for incremental mode
- Any direction specification as start (see section "Assignment of the Feedback and Control Interfaces (Page 49)")

Note

The 1STEP 5V checks the set position for limits (minimum 0 and maximum 16777215). The full-scale value can be configured.

The traversing job is only executed if you have determined or specified the position of the home position beforehand (the SYNC bit has to be set, see section "Search for Reference (Page 28)" or "Set home position (Page 31)").

The control signal "Hold at reference cam" is not taken into consideration (see section "Assignment of the Feedback and Control Interfaces (Page 49)").

Feedback messages

The POS_RCD feedback bit is reset at the beginning of incremental mode.

While the incremental mode is active, it is indicated by the set POS feedback bit.

After incremental mode has been correctly executed, the set POS_RCD feedback bit indicates that the position has been reached.

If the incremental mode is interrupted, the POS_RCD feedback bit remains reset. After incremental mode has been stopped, the distance still to be traversed is displayed if the feedback value is set to "Residual distance (see section "Assignment of the Feedback and Control Interfaces (Page 49)").

2.7.7 Speed-control mode

Description of the function

In this operating mode you specify the frequency with which the pulses (steps) are output. When you change the frequency, the pulses are output with the new frequency after an acceleration or deceleration phase. The output is carried out continuously until you stop the traversing job or a traversing range is reached at a linear axis.

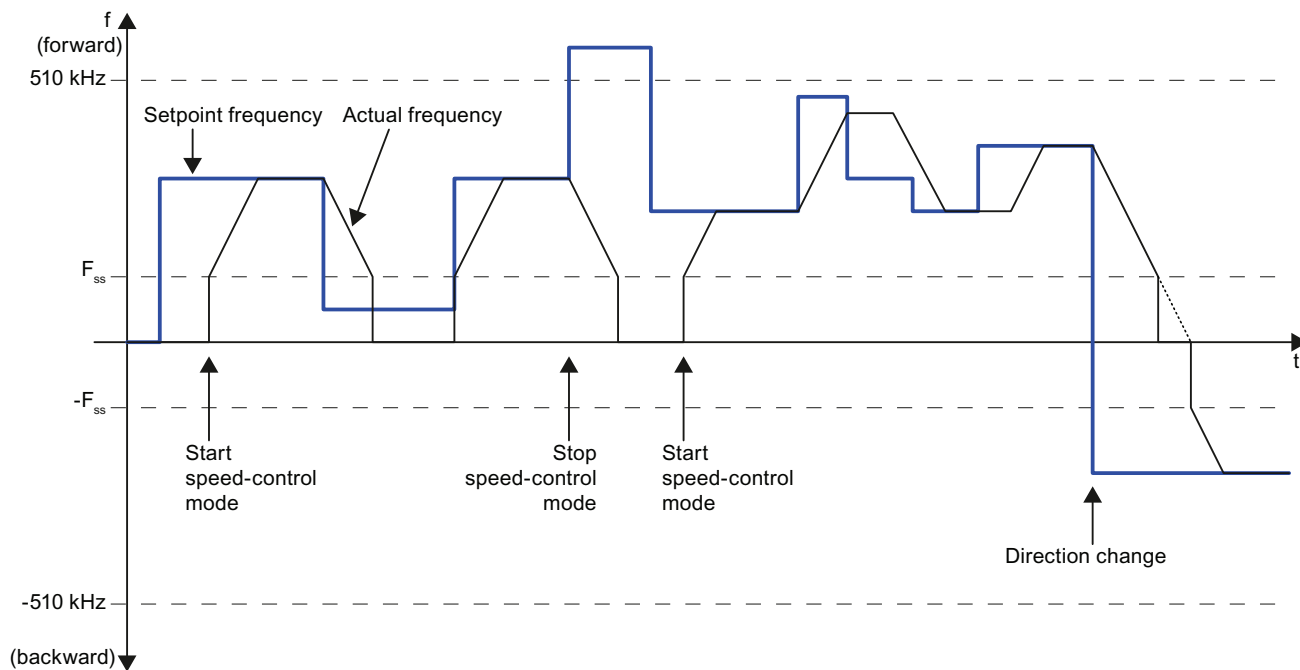

Figure 2-11 Speed-control mode with modulo axis

Traversing job for speed-control mode

The traversing job contains the following information:

- Setpoint frequency as 32-bit value (STEP 7 data type REAL)
- Direction specification by the sign of the setpoint frequency (positive: forward)
- Mode = 3 for speed-control mode
- Any direction specification as start (see section "Assignment of the Feedback and Control Interfaces (Page 49)")

Note

The 1STEP 5V checks the set position for limits (minimum -510,0 kHz and maximum +510,0 kHz).

The specified frequency is approached with the configured acceleration a under consideration of the start-stop frequency F_{ss} . No pulse output is emitted at frequencies that are less than F_{ss} .

The continuous output of the frequency is terminated at the following events:

- Reaching of the limits of the configured traversing range (0 in the direction backward) unless a modulo axis is configured
 - Other aborting conditions for traversing jobs (see section "Hold traversing job (Page 36)").
-

Feedback messages

While the traversing job is active, it is indicated by the set POS feedback bit.

When a new frequency is specified, the POS_RCD feedback bit is cleared. When the new frequency has been reached after the acceleration or deceleration phase, POS_RCD is set again.

The current frequency is displayed in the feedback interface as a 32-bit value (STEP 7 data type REAL) if the feedback value is set to "Frequency" (see section "Assignment of the Feedback and Control Interfaces (Page 49)").

2.7.8 Hold traversing job

Specific holding of the traversing job

- Caused by	Displayed by Feedback Bit
STOP by control bit	-
External STOP at digital input	STOP_EXT
Limit switch in the forward direction reached (LIMIT_P or digital input)	STOP_LIMIT_P
Limit switch in the backward direction reached (LIMIT_M or digital input)	STOP_LIMIT_M
STOP at the reference cam	STOP_REF

Note

Remember that the limit switches are used in the reference point approach mode also to search for the reference cam.

If a drive job was stopped at LIMIT_P, you can move the axis away from the limit switch with a new drive job DIR_M. With a stop at LIMIT_M you can move the axis away from the limit switch with DIR_P.

Stop at the reference cam

If the "Hold at reference cam" function is selected (the control bit STOP_REF_EN is set) at the start of traversing and the reference cam is detected during traversing, the stepping motor is halted and traversing is terminated.

Holding the traversing job in exceptional circumstances

In the following cases the traversing job is halted with loss of the synchronization:

- Incorrect operation in the control interface during an active traversing job
- External error ERR_24V through overload of the encoder supply (e.g. short circuit)
- CPU/master STOP
- At linear axis: Reaching of the limit of the traversing range

Effects

If one of the above reasons for holding the current positioning operation occurs, it is terminated by a deceleration ramp.

The return value continues to be updated even when the traversing job is halted in exceptional cases. This enables you to traverse the residual distance after holding by means of a new traversing job in the "Relative incremental mode".

Limit Switches and External STOP

By assigning parameters, you can choose to wire normally open or normally closed contacts for the external STOP and the limit switches.

- **Normally closed contact means:** The external STOP and the effect of the limit switches are triggered by a 0 signal. When the limit switches are reached, delete the associated control bit.
- **Normally open contact means:** The external STOP and the effect of the limit switches are triggered by a 1 signal. When the limit switches are reached, set the associated control bit.

Note

In case of holding during the acceleration phase the 1STEP 5V continues to send pulses for a maximum of 50 ms at the frequency already reached before it starts braking. This avoids abrupt changes in frequency, which can lead to step losses.

2.7.9 Axis type and traversing range

Overview

During configuration you specify the axis type to be controlled by the stepping motor controlled by 1STEP 5V. You have the choice of the following axis types:

- Linear axis
- Modulo axis

Description of the function

Linear axis

The traversing range of a linear axis can be set. The low limit is always 0, the high limit is configured and has a value range of 1 to 16777215.

The traversing range can be limited further by limit switches (working range).

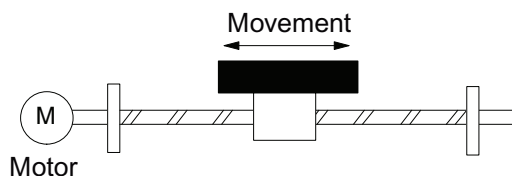

Figure 2-12 Linear axis

Modulo axis

A modulo axis is a particular form of the rotary axis.

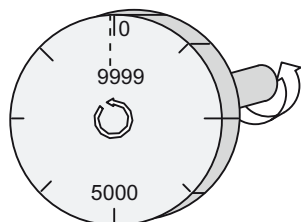

Figure 2-13 Modulo axis

End of the modulo axis

The "Traversing range" parameter is used to specify the end of the modulo axis.

The actual position value cannot reach the traversing range value, because this highest value lies physically at the same position as the start of the modulo axis (0).

Example:

You specify the value 10000 as the traversing range, see figure above.

During a forward movement the position value jumps in the feedback interface from 9999 to 0, during a backward movement from 0 to 9999.

Reference point approach

If you have selected the modulo axis during the configuration and have assigned a reference cam to your drive system, you can carry out a reference point approach (see section "Search for Reference (Page 28)").

Traversing is aborted unsuccessfully if the reference cam is not found after the output of a number of pulses that corresponds to the configured traversing range. The SYNC and POS_RCD status bits then remain deleted.

Set home position

You may only specify values from 0 to the end of the configured end of the traversing range – 1 for the position of the home position.

Relative positioning

The end of the traversing range (end of the modulo axis) may be exceeded in both directions.

Absolute positioning

If you have selected the modulo axis during the configuration, you may only specify values from 0 to the configured end of the traversing range – 1 for the target position.

In contrast to the linear axis you specify by means of the direction specification when the traversing job is started by which path the target position is to be reached (see section "Assignment of the Feedback and Control Interfaces (Page 49)"):

- Backward start (DIR_M): The 1STEP 5V approaches the target position in the direction of lower actual position values (Option 1 in the following figure).
- Forward start (DIR_P): The 1STEP 5V approaches the target position in the direction of higher actual position values (Option 2 in the following figure).
- Forward start and backward start simultaneously (DIR_P and DIR_M): The 1STEP 5V automatically selects the shortest path for reaching the target position (Option 1 in the following figure).

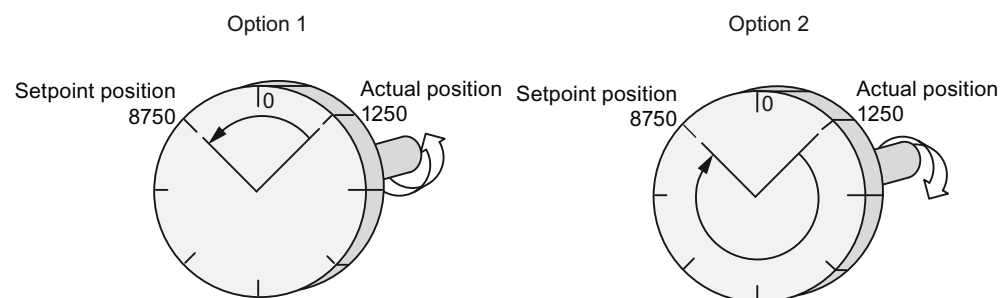

Figure 2-14 Absolute incremental mode with modulo axis

2.7.10 Pulse Enable

Description of the function

Pulse enable permits the output of pulses from the 1STEP 5V to the power unit. A run is not possible without pulse enable.

Activating Pulse Enable

You can activate pulse enable by one of the following methods:

- Through the digital input DI0 when "Function DI0" is configured as an external pulse enable (see section "Behavior of the Digital Inputs (Page 42)")

or

- Through the control bit DRV_EN when the "Function DI0" is configured as an external STOP or limit switch forward or backward (see section "Behavior of the Digital Inputs (Page 42)")

You can recognize the assigned pulse enable through the fact that

- The RDY LED at the 1STEP 5V light up in case of correct configuration.
- The STS_DRV_EN feedback bit is set.

Deleting the Pulse Enable

Deleting the pulse enable during a run terminates the run immediately because no more pulses are emitted to the power unit. The residual distance and actual position value are no longer valid. The synchronization of the axis by means of the reference point is lost. The SYNC feedback bit and the RDY LED are deleted.

Deleting the pulse enable when the motor is at standstill deletes the SYNC feedback bit and the RDY LED.

In this case it may be necessary to carry out a reference point approach.

2.7.11 Changing Parameters during Operation

Introduction

You can change several of the 1STEP 5V parameters during operation without having to reassign the parameters of the whole ET 200S station.

Parameters That Can Be Changed

The following parameters can be changed:

- Base Frequency F_b :
- Multiplier n for start-stop frequency F_{ss}
- Multiplier i for acceleration / delay
- Feedback value in the feedback interface

When you start changing parameters by means of the C_PAR control bit, the parameters are checked for permitted values (see section "Parameter assignment (Page 45)"). If you have set invalid values, the ERR_JOB feedback bit is set.

Only the feedback bits for the ERR_JOB and STS_JOB job processing are affected by the configuration job.

2.7.12 Behavior of the Digital Inputs

Introduction

You can configure the function and the behavior (active level) of the digital inputs DI0 (3) and DI1 (7). These parameters cannot be changed using the user program.

Digital input DI0 (3)

You can configure the function of the digital input DI0 (3) as:

- An external pulse enable
- An external STOP
- Limit switch in the forward direction
- Limit switch in the backward direction

You can also configure the behavior of the digital input DI0 (3) as:

- Normally closed contact
- Normally open contact

Digital input DI0 (3) as an external pulse enable

The input must be put into operation (activated). If the input is set and the configuration correct, the 1STEP 5V is ready for operation (see section "Pulse Enable (Page 40)").

Digital input DI0 (3) as an external STOP

With this input function, you can halt a current transverse job by means of an external signal (see section "Hold traversing job (Page 36)").

Digital input DI0 (3) as a limit switch in the direction forward or backward

With these input functions, you limit the traversing range in the forward or backward direction through an external signal. The signal has the same effect as one of the two control bits LIMIT_P or LIMIT_M in the control interface (see section "Assignment of the Feedback and Control Interfaces (Page 49)").

Digital input DI1 (7)

You can configure the function of the digital input DI1 (7) as:

- A reference switch (reference cam)
- Reference switch and limit switch in the forward direction
This parameter selection is only possible if "Function DI0" is not configured as a "Limit switch forward".
- Reference switch and limit switch in the backward direction
This parameter selection is only possible if "Function DI0" is not configured as a "Limit switch backward".

You can also configure the behavior of the digital input DI1 (7) as:

- Normally closed contact
- Normally open contact

Digital input DI1 (7) as a reference switch

You can wire a switch to this input for the reference cam.

You need a reference cam for the following:

- For a reference point approach
- For an incremental mode with hold on the reference cam.

Digital input DI1 (7) as a reference switch and limit switch in the direction forward or backward

With these input functions, you additionally limit the traversing range in the forward or backward direction through the reference cam. The signal additionally has the same effect as one of the two control bits LIMIT_P or LIMIT_M in the control interface (see section "Assignment of the Feedback and Control Interfaces (Page 49)").

If you have configured the behavior of the digital input DI1 (7) as a "Reference switch and limit switch", the 1STEP 5V automatically selects the starting direction toward the limit switch, irrespective of the direction specified in the traversing job.

2.7.13 Behavior at CPU-Master-STOP

Introduction

The 1STEP 5V detects the CPU/master STOP. It reacts to this by stopping the active traversing job (see section "Hold traversing job (Page 36)").

Exiting the CPU-Master-STOP Status

ET 200S station	1STEP 5V
Without reconfiguration of the ET 200S station	<ul style="list-style-type: none"> The feedback interface of the 1STEP 5V remains current. The values changed by means of parameter assignment job are maintained. If a control bit was set (DIR_P, DIR_M, C_PAR) when the CPU/master STOP occurred, the bits STS_JOB and ERR_JOB are set when the CPU/master STOP status is exited. Delete the control bit. Traversing / the parameter assignment job is not executed. You can then start a new traversing by means of the control bit. After the delay ramp, the pulse enable, the RDY LED, and the SYNC status bit are deleted.
With reconfiguration of the ET 200S station	<ul style="list-style-type: none"> Information on previous searches and parameter assignment jobs is reset. If pulse enable was activated by means of the control bit DRV_EN at the time of the CPU/master STOP, the pulse enable, the RDY LED, and the SYNC status bit are deleted after the delay ramp.

Reconfiguration of the ET 200S station

Reconfiguration of the ET 200S station is carried out by your CPU/ DP master at:

- POWER ON of the CPU / DP master
- POWER ON of the IM 151 / IM 151 FO
- After failure of the DP transmission
- Upon loading changed parameters or configuration of the ET 200S station into the CPU / DP master
- When the 1STEP 5V is plugged
- Upon power on or inserting of the appropriate power module

See also

Pulse Enable (Page 40)

2.8 Parameter assignment

Setting the Parameters

You set the parameters for the 1STEP 5V by means of the GSD file for the ET 200S using the STEP 7 parameter assignment software.

Parameter List

You can enter the following parameters (default **bold**):

Parameter	Value range	Explanation
Enable		
Group diagnostics	Disable /enable	If you have enabled group diagnostics, the "Sensor supply short circuit" error or "Parameter assignment error" results in a channel-specific diagnostics.
Traversal Frequency		
Base Frequency F_b : in Hz	2000 / 800 / 400 / 200 / 80 / 40 / 20 / 8 / 4	This is the base value for setting the start-stop frequency, the output frequency, and the acceleration / deceleration.
Multiplier n: $F_{ss} = F_b \times n$	1 ... 255	Using the multiplier n, you can set the start-stop frequency in steps.
Acceleration/Delay		
Time interval i: $a = F_b / (i \times 0.128 \text{ ms})$	1 ... 255	Using the multiplier i, you can set the acceleration / deceleration in steps.
Digital Inputs		
Function DI0	External pulse enable / external STOP / Limit switch forward / Limit switch backward	-
Function DI1	Reference switch / Reference switch and limit switch forward / Reference switch and limit switch backward	-
Input DI0	Normally closed contact / normally open contact	-
Input DI1	Normally closed contact / normally open contact	-
Limit switch in the control interface	Normally closed contact / normally open contact	-
Feedback interface		
Feedback value	Residual distance / position / frequency	-
Axis type and traversing range		
Modulo axis	No / Yes	-
Travel range	1 ... 16777216	-

Causes of Parameter Assignment Errors

- Invalid base frequency
- Multiplier n = 0
- Multiplier i = 0
- Invalid combination of the functions of the digital inputs (both as limit switch forward or both as limit switch backward)
- Invalid feedback value for the feedback interface
- Traversing range out of range of values

2.9 Diagnostics

2.9.1 Diagnostics using the LED display

LED display on the 1STEP 5V

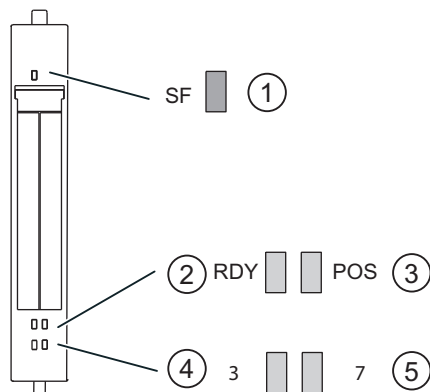

- ① Group error (red)
- ② Ready for traversing job (green)
- ③ Positioning underway (green)
- ④ Status display for Digital input 0 (green)
- ⑤ Status display for Digital input 1 (green)

Status and error displays by means of LEDs on the 1STEP 5V

The table below shows the status and error displays on the 1STEP 5V.

Event (LEDs)					Cause	Remedy
SF	RDY	POS	3	7		
On					No configuration or incorrect module plugged in. There is a diagnostic message.	Check the parameter assignment. Evaluate the diagnostics data.
	On				If parameters were assigned to the module correctly and pulse enable has been activated	
		On			When traversing job is running	
			On		DI 0 is activated.	
				On	DI 1 is activated.	

2.9.2 Error types

For information on the structure of the channel-related diagnostics, refer to the manual on the interface module used in your ET 200S station.

1STEP 5V error types

The following table shows the error types on the 1STEP 5V.

Error type		Meaning	Remedy
1D	00001: Short circuit	Short circuit of the sensor supply.	Check the connection to the switches. Correct the process wiring.
9D	01001: Error	Internal module error occurred.	Replace the module.
16D	10000: Parameter assignment error	Parameters have not been assigned to the module.	Correct the parameter assignment.

2.10 Feedback and Control Interface

2.10.1 Assignment of the Feedback and Control Interfaces

Interface Assignment

Note

For the 1STEP 5V, the following data of the control and feedback interface are consistent:

- Bytes 0 to 3
- Bytes 4 to 7

Use the access or addressing mode for data consistency over the entire control and feedback interface on your DP master (only for configuration using the GSD file).

You can see the assignment of the inputs and outputs in the following tables:

Table 2-3 Assignment of the Inputs (I): Feedback interface

Address	Assignment		
Bytes 0 to 3	Residual distance (Bits 23 to Bit 0 of 32 bits) / Position (Bits 23 to Bit 0 of 32 bits) / Frequency (32 bits, STEP 7 data type REAL)		
Byte 4	Bit 7	Short circuit of the encoder supply	ERR_24V
	Bit 6	Reserve = 0	
	Bit 5	Parameter assignment error	ERR_PARA
	Bit 4	Determining the home position	SYNC
	Bit 3	Reserve = 0	
	Bit 2	Position reached	POS_RCD
	Bit 1	Error during job transfer	ERR_JOB
	Bit 0	Job transfer running	STS_JOB
Byte 5	Bit 7	Traversing job running	POS
	Bit 6	Limit switch forward is cause for stop	STOP_LIMIT_P
	Bit 5	Limit switch backward is cause for stop	STOP_LIMIT_M
	Bit 4	External STOP is cause for stop	STOP_EXT
	Bit 3	Reference cam is cause for stop	STOP_REF
	Bit 2	Status DI0	STS_DI0
	Bit 1	Status DI1	STS_DI1
	Bit 0	Status pulse enable active	STS_DRV_EN
Byte 6	Error number at an error during job transfer		
Byte 7	Reserve = 0		

Table 2- 4 Assignment of the Outputs (O): Control interface

Address	Assignment
Bytes 0 to 3	Relative incremental mode, absolute incremental mode
	Byte 0 Multiplier G: $F_a = F_b \times R \times G$ (value range 1 to 255)
	Byte 1 Distance or position Bit 23 to Bit 16
	Byte 2 Distance or position Bit 15 to Bit 8
	Byte 3 Distance or position Bit 7 to Bit 0
	Reference point approach
	Byte 0 Multiplier G: $F_a = F_b \times R \times G$ (value range 1 to 255)
	Byte 1 Position Bit 23 to Bit 16
	Byte 2 Position Bit 15 to Bit 8
	Byte 3 Position Bit 7 to Bit 0
	Set home position
	Byte 0 Reserve = 0
	Byte 1 Position Bit 23 to Bit 16
	Byte 2 Position Bit 15 to Bit 8
	Byte 3 Position Bit 7 to Bit 0
	Speed-control mode
	Bytes 0 to 3 Frequency as STEP 7 data type REAL
	Parameter Assignment Request
	Byte 0 Reserve = 0
	Byte 1 Multiplier i: $a = F_b \times R / (i \times 0.128 \text{ ms})$ (value range 1 to 255)
	Byte 2 Multiplier n: $F_{ss} = F_b \times n \times R$ (value range 1 to 255)
	Byte 3 Base frequency F_b : <ul style="list-style-type: none"> • 0 = 800 Hz • 1 = 400 Hz • 2 = 200 Hz • 3 = 80 Hz • 4 = 40 Hz • 5 = 20 Hz • 6 = 8 Hz • 7 = 4 Hz • 8 = 2000 Hz

Address	Assignment		
Byte 4	Bit 7	Reduction factor <ul style="list-style-type: none"> • 0 = Factor 1.0 (no reduction) • 1 = Factor 0.1 	R
	Bit 6	Hold traversing job	STOP
	Bit 5	Backward start	DIR_M
	Bit 4	Forward start	DIR_P
	Bit 3	Reserve = 0	
	Bit 2 to Bit 0	Mode <ul style="list-style-type: none"> • 0 = Relative incremental mode (relative positioning) • 1 = Reference point approach • 2 = Absolute incremental mode (absolute positioning) • 3 = Speed-control mode • 4 = Set home position 	MODE
Byte 5	Bit 7	Diagnostics error acknowledgment	EXTF_ACK
	Bit 6	Change parameter	C_PAR
	Bit 5 to Bit 4	Feedback value in the feedback interface <ul style="list-style-type: none"> • 00 = Residual distance • 01 = Position • 10 = Frequency • 11 = Reserved 	FEEDBACK
	Bit 3	Stop at the reference cam	STOP_REF_EN
	Bit 2	Pulse enable	DRV_EN
	Bit 1	Limit switch in the forward direction	LIMIT_P
	Bit 0	Limit switch in the backward direction	LIMIT_M
	Reserve = 0		
Byte 6	Reserve = 0		
Byte 7	Reserve = 0		

Notes on the Feedback Bits

Table 2- 5 Feedback bits

Feedback Bits	Notes
Frequency	A 32-bit value (STEP 7 data type REAL) that contains the current pulse frequency. The pulse frequency can assume positive (forward direction) and negative (backward direction) values.
ERR_JOB	This bit is set if the job is not clear or not possible. The error cause is specified in more detail by the returned error number (see the following table "Error number in the feedback interface").
ERR_PARA	Incorrect parameter assignment for the ET 200S station. The error cause is specified in more detail by the returned error number (see the following table "Error number in the feedback interface"). The parameter error bit is deleted when a correct parameter assignment is transmitted.
ERR_24V	The encoder supply has been overloaded (e.g. by a short circuit) and is now switched off. ERR_24V is reset if it has been acknowledged with the EXTF_ACK control bit. After the overload has been eliminated, the encoder supply is switched on again and ERR_24V remains cleared.
Error number	Specifies the error cause if ERR_JOB or ERR_PARA is set (see table below "Error numbers in the feedback interface").
POS	Traversing: This bit is set as long as the traversing job is running.
POS_RCD	POS_RCD is cleared at the start of an incremental mode or at specification of a new setpoint frequency in speed-control mode. POS_RCD is set after a correctly executed incremental mode or when the setpoint frequency has been reached in speed-control mode. If traversing was interrupted (if the traversing job has stopped or the pulse enable is deleted), POS_RCD remains cleared (see section "Hold traversing job (Page 36)" and "Pulse Enable (Page 40)").
Position	A 24-bit value that contains the current absolute position (without signs). Byte 0 of the feedback interface is 0.
Residual distance	A 24-bit value that contains the number of pulses that still have to be traversed (without signs). Byte 0 of the feedback interface is 0.
STOP_EXT	Cause for stop: This bit is set if the traversing job has been stopped by an external STOP.
STOP_LIMIT_M	Cause for stop: This bit is set if the traversing job has been stopped by reaching of the limit switch backward.
STOP_LIMIT_P	Cause for stop: This bit is set if the traversing job has been stopped by reaching of the limit switch forward.
STOP_REF	Cause for stop: This bit is set if the traversing job has been stopped by reaching of the reference cam.
STS_DI0	The bit displays the status of the DI0 (3) digital input.
STS_DI1	The bit displays the status of the DI1 (7) digital input.
STS_DRV_EN	This bit is set when one of the following occurs, depending on the assigned parameter function of the digital input DI0: <ul style="list-style-type: none"> • The external pulse enable is set. or <ul style="list-style-type: none"> • The DRV_EN control bit is set for the pulse enable.
STS_JOB	This bit is set as feedback when a job request for a traversing or parameter assignment job is detected and then reset when the job has been executed.
SYNC	This bit is set after a correct reference point approach or after manual specification of the home position has been set. The SYNC bit is cleared after parameter assignment with new ET 200S station parameters or after deletion of the pulse enable.

Error number

If an error with the job transfer (ERR_JOB is set) or an error in the basic parameter assignment (ERR_PARA is set) is displayed in the feedback interface, the error cause is specified in more detail by means of an error number.

Table 2- 6 Error numbers in the feedback interface

Error number	Meaning
General error causes	
0	No error (then ERR_JOB or ERR_PARA is also not set)
1	Combination of the control bits (DIR_P, DIR_M, C_PAR) is invalid
2	Another job is still running.
Causes of errors with a traversing job	
16	Start forward (DIR_P) at limit switch forward (LIMIT_P) active
17	Start backward (DIR_M) at limit switch backward (LIMIT_M) active
18	Start with set control bit STOP
19	Start at external STOP active
20	Start at a missing pulse enable (internal or external)
21	Start with set STOP_REF_EN with active reference cam
22	Start without reference (at absolute incremental mode)
23	Start with diagnostic error present
24	Start was interrupted by CPU/master STOP
25	Start with incorrect operating mode (not identical with requirement)
26	Distance or position specification is invalid
27	Multiplier G for the velocity is zero
28	Frequency is invalid at speed-control mode
Error causes at a parameter assignment job or for the basic parameter assignment	
32	Specification for the basic frequency is invalid
33	Multiplier n for start-stop frequency is zero
34	Multiplier i for acceleration / delay is zero
35	Feedback value for the feedback interface is invalid
36	Combination of the functions of DI0 and DI1 is invalid (limit switches)
37	Specification for the end of the traversing range is invalid

Notes on the Control Bits

Table 2-7 Control bits

Control Bits	Notes
Base frequency F_b :	Coding for setting the base frequency in steps: <ul style="list-style-type: none"> • 0 = 800 Hz • 1 = 400 Hz • 2 = 200 Hz • 3 = 80 Hz • 4 = 40 Hz • 5 = 20 Hz • 6 = 8 Hz • 7 = 4 Hz • 8 = 2000 Hz
Operating mode	Coding for operating mode: <ul style="list-style-type: none"> • 0 = Relative incremental mode (relative positioning) • 1 = Reference point approach • 2 = Absolute incremental mode (absolute positioning) • 3 = Speed-control mode • 4 = Set home position
C_PAR	A parameter change is requested with this bit.
DIR_M	This bit requests and starts a traversing job in the backward direction.
DIR_P	This bit requests and starts a traversing job in the forward direction.
Frequency	A 32-bit value (STEP 7 data type REAL) that contains the pulse frequency to be output.
DRV_EN	If you use the DI0 (3) digital input as an external STOP, this bit is interpreted as a pulse enable.
Limit switch LIMIT_M	This limit switch limits the travel range in the backward direction. You set or delete this bit in your user program.
Limit switch LIMIT_P	This limit switch limits the travel range in the forward direction. You set or delete this bit in your user program.
EXTF_ACK	Acknowledgment bit for diagnostic message
Multiplier G	Factor for setting the velocity / output frequency in steps
Multiplier i	Factor for setting the acceleration / deceleration in steps
Multiplier n	Factor for setting the start-stop frequency in steps
Position	24-bit value that contains the target position to be approached
Reduction factor R	The base frequency F_b is multiplied by 0.1 if the bit is set. This reduces the output frequency F_a , the start-stop frequency F_{ss} , and the acceleration / deceleration a by the same amount.
STOP	With this bit, you can stop a traversing job with a delay ramp at any time (see section "Hold traversing job (Page 36)").
STOP_REF_EN	When the bit is set, the "Stop at the reference cam" function is active. When the reference cam is recognized, the traversing job is stopped with a delay ramp (see section "Hold traversing job (Page 36)").

Control Bits	Notes
FEEDBACK	Coding for the feedback value in the feedback interface: <ul style="list-style-type: none"> • 00 = Residual distance • 01 = Position • 10 = Frequency • 11 = Reserved
Distance	A 24-bit value that contains (without signs) the number of pulses that have to be traversed.

Access to Control and Feedback Interface in STEP 7 Programming

	Configuring with STEP 7 via GSD file ¹⁾ (hardware catalog\PROFIBUS-DP\Other Field Devices\ET 200S)	Configuring with STEP 7 using HW Config (hardware catalog\PROFIBUS DP\ET 200S)
Feedback interface	Read with SFC 14 "DPRD_DAT"	Load command, e.g. L PED
Control interface	Write with SFC 15 "DPWR_DAT"	Transfer command, e.g. T PAD
¹⁾ Load and transfer commands are also possible with CPU 3xxC, CPU 318-2 (as of V3.0), CPU 4xx (as of V3.0)		

2.10.2 Traversing job, changing parameters and troubleshooting

Starting the traversing job

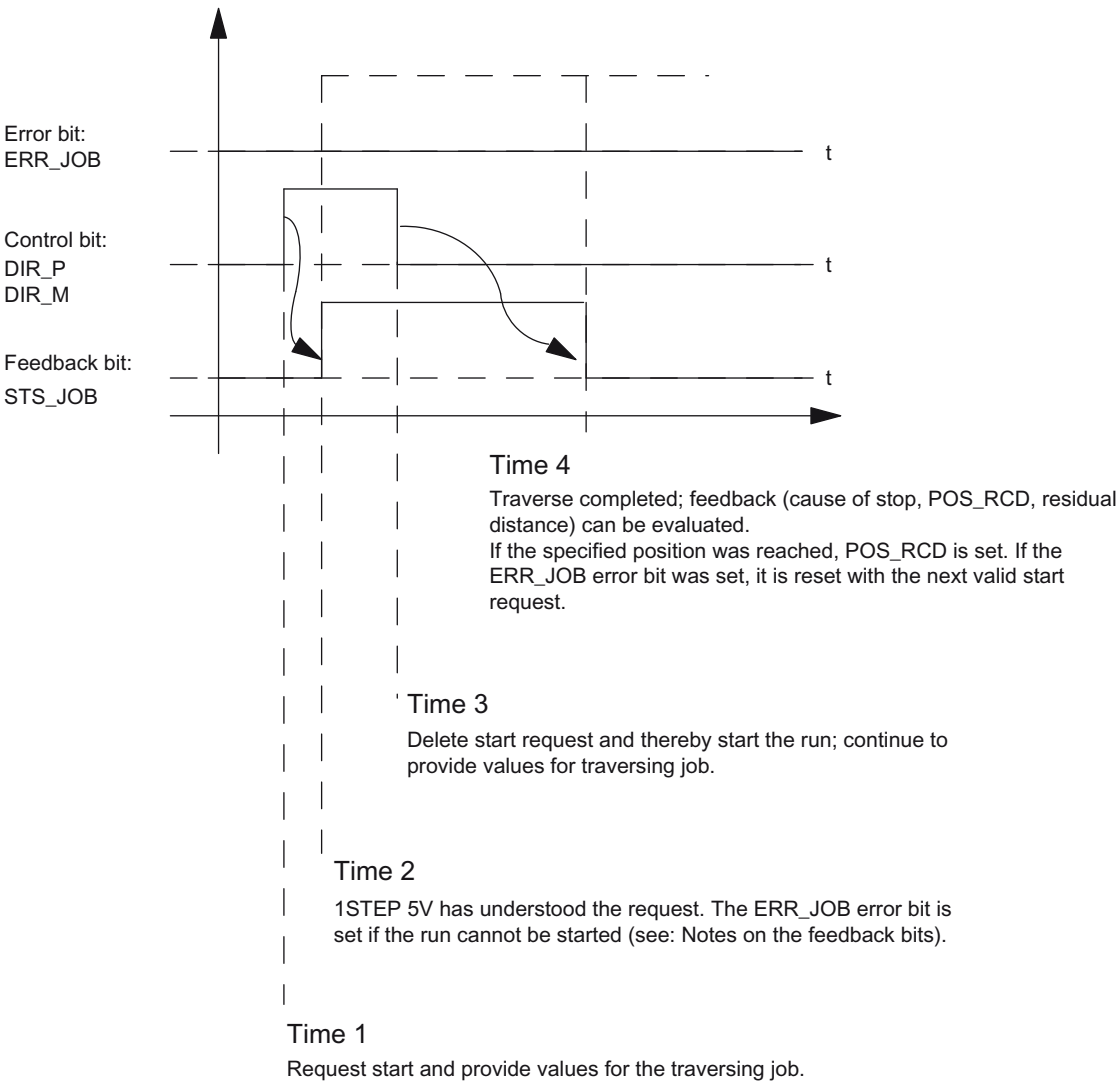

Figure 2-15 Starting the traversing job

Evaluating the ERR_JOB error bit

As soon as the STS_JOB feedback bit is cleared at time stamp 4, evaluate the ERR_JOB error bit. Note that the STS_JOB feedback bit is only cleared if the DIR_P, DIR_M, and C_PAR control bits are cleared.

Carrying Out a Parameter Change

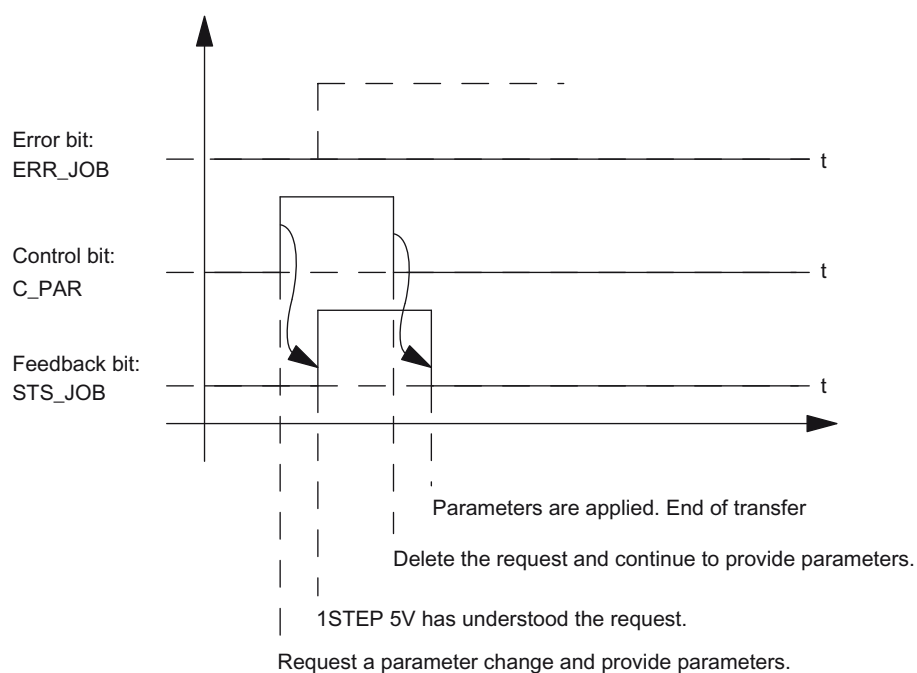

Figure 2-16 Carrying Out a Parameter Change

Note

Only one of the following control bits can be set at a particular time:

DIR_Por DIR_Mor C_PAR.

Otherwise, the ERR_JOB error is reported. The job error message is deleted by the start of the next job.

Error detection

The "Encoder supply short circuit" error has to be acknowledged. It has been detected by the 1STEP 5V and indicated in the feedback interface. Channel-specific diagnostics are executed if you enabled group diagnostics when you assigned parameters.

The parameter assignment error bit is acknowledged by means of correct parameter assignment.

An error occurs, the 1STEP 5V sets an error bit, a diagnostic message may appear.

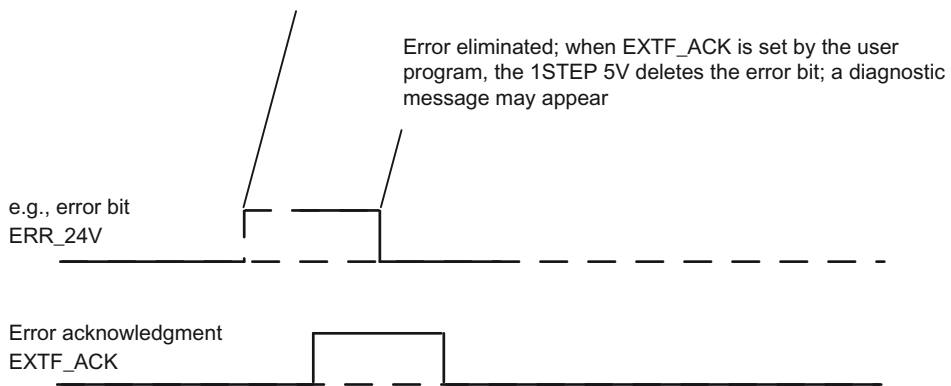

Figure 2-17 Error Acknowledgment

In the case of constant error acknowledgment (EXTF_ACK = 1) or in CPU/master STOP mode, the 1STEP 5V reports the error as soon as it is detected and clears the error as soon as it is eliminated.

2.11 Technical Specifications

Technical Specifications

Technical specifications 1STEP 5V	
Dimensions and weight	
Dimensions W × H × D (mm)	15 × 81 × 52
Weight	Approx. 40 g
Data for specific modules	
Number of channels	1
Voltages, currents, potentials	
Rated load voltage L+	24 VDC
• Reverse polarity protection	Yes
Isolation	
• Between the backplane bus and the positioning function	Yes
• Between the positioning function and load voltage	No
Encoder supply	
• Output voltage	L+ (-0.8 V)
• Output current	Maximum 500 mA (total current at terminals 2 and 6), short circuit proof
Current consumption	
• From the backplane bus	Max. 10 mA
• From the load voltage L+ (no load)	Typ. 40 mA
Power loss of the 1STEP 5V	Typ. 1.5 W
Data for the digital inputs	
Isolation	No, only from shield and backplane bus
Input voltage	
• Rated value	24 VDC
• 0 signal	-30 ... 5 V
• 1 signal	11 ... 30 V
Input current	
• 0 signal	Max. 2 mA (standby current)
• 1 signal	9 mA (typically)
Input delay	4 ms
Connection of a two-wire BERO Type 2	Possible
Input characteristic curve	To IEC 1131, Part 2, Type 2
Length of cable	
• Shielded	Max. 1000 m
• Unshielded	Max. 600 m

Technical specifications 1STEP 5V	
Connection to the power unit (data to the outputs)	
The cables to the power unit must be twisted in pairs and shielded.	Max. 100 m
Differential signals for pulses and direction	To RS 422
Status, interrupts, diagnostics	
Status display digital input DI0	LED 3 (green)
Status display digital input DI1	LED 7 (green)
Status display ready for operation	LED RDY (green)
Status display positioning in operation	LED POS (green)
Fault display at the 1STEP 5V	LED SF (red)
Diagnostic information	Yes
Response Times	
Update rate of the feedback interface	2 ms
Deletion of the start request until pulse output	Response time DP master + response time ET 200S + 2 ms + 1 / (2 × F _{ss})

1PosUniversal

3.1 Product overview

Order number

6ES7 138-4DL00-0AB0

Features

- **Positioning module 1PosUniversal (1PosU) for controlled positioning by means of rapid / creep speed**
 - Switchover and switch-off difference can be set using your control program
- **An incremental encoder with 5 V differential signals or 24 V signals**
 - With or without zero mark
 - Quadruple evaluation of the encoder signals
 - Dosing operation (1-fold evaluation only of the encoder signal A)
- **SSI encoder with Gray code**
 - 13-bit Singleturn
 - 25-bit Multiturn
- **Usable axis types**
 - Linear axis
 - Rotary axis
- **Operating range: 0 - 16 777 215 increments**
- **The drive can be controlled via 3 digital outputs:**
 - Travel minus / rapid speed
 - Travel plus / creep speed
 - Rapid/creep speed or travel plus/minus
- **3 digital inputs can be used for the following:**
 - Hardware limit switch minus
 - Hardware limit switch plus
 - Reducing cam/latch input
- **Diagnostics**
 - Encoder monitoring
 - Load voltage monitoring

- **Firmware update¹⁾**
 - In order to extend the functionality and eliminate errors, firmware updates can be downloaded to the operating system memory of the 1PosU by means of the STEP 7 HW Config software.

Note

When you start the firmware update, the old firmware is deleted. If the firmware update is interrupted or canceled for any reason, 1PosU will no longer function correctly as a result. Restart the firmware update and wait until it has completed successfully.

- **Information function ¹⁾**
 - Hardware version
 - Firmware product version
 - Serial number

¹⁾ The function is only available if the used interface module supports the required system services

Configuration

In order to configure the 1PosU use one of the following

- A GSD file (<http://www.automation.siemens.com/csi/gsd>)
- STEP 7 as of Version V5.3 SP2 or with the HSP (hardware support package, available online) as of STEP 7 Version V.5.2 SP1

3.2 Safety concept

Principle

The following measures are vital to the safety of the system. Install them with particular care, and adapt them to meet the requirements of the system.

Check the measures are effective before the first run.

<p>⚠ WARNING</p> <p>To avoid injury and damage to property, make sure you adhere to the following:</p> <ul style="list-style-type: none"> • Install an emergency stop system in keeping with current technical standards (for example, EN 60204, EN 418, etc.). • Make sure that no one has access to areas of the system with moving parts. • Install, for example, safety limit switches for the end positions of the axes that switch off the power control system directly. • Install devices and take steps to protect motors and power electronics.
--

Setting up a positioning control

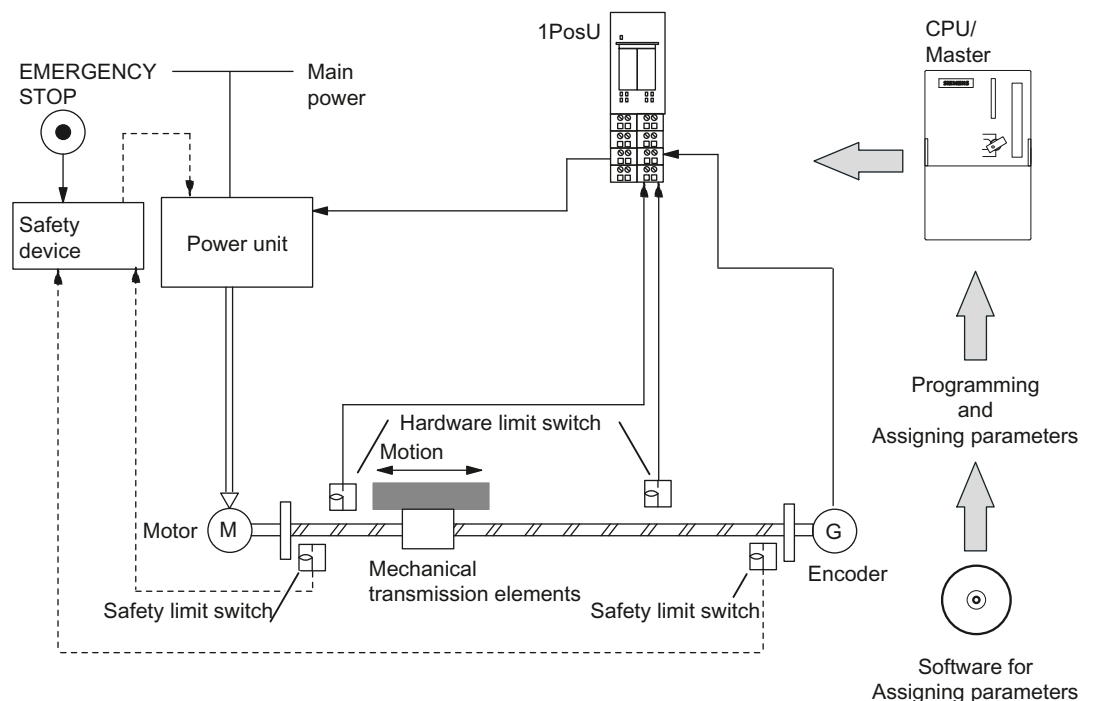

Figure 3-1 Design of a Positioning Control System (Example)

3.3 Brief Instructions on Commissioning the 1PosU

Introduction

These brief instructions guide you to a functioning application that will enable you to become familiar and check the basic hardware and software involved in a positioning operation of your 1PosU. The inching mode used in this example.

Prerequisites for the Example

The following prerequisites must be fulfilled:

- You must have put an ET 200S station on an S7 station with a DP master into operation.
- You must have:
 - A terminal module TM-E30x44-01
(order number 6ES7 193-4CGx0-0AA0)
 - A 1PosU
(order number 6ES7 138-4DL00-0AB0)
 - A position encoder (incremental encoder with 5 V differential signals, incremental encoder with 24 V signals or SSI encoder)
 - A drive with power control (e.g. a pole-changing motor with contactor switching)
 - A 24 VDC power supply
 - The necessary wiring material

Installation, Wiring, and Fitting

Install and wire the TM-E30x44-01 terminal module. Insert the 1PosU in the terminal module (you can find detailed instructions in the *ET 200S Distributed I/O System* operating instructions).

Table 3- 1 Terminal assignment of the 1PosU

Terminal assignment	View	Remarks																	
<div style="border: 1px solid black; padding: 5px;"> <p>1 POS Universal Digital</p> <p>SF □</p> <p>1 □ □ 5 UP □ □ DN</p> <p>2 □ □ □ POS</p> <p>6ES7 138-4DL00-0AB0</p> <table border="1" style="width: 100%; text-align: center;"> <tr> <td>9</td><td>A/D</td> <td>13</td><td>\bar{A}/\bar{D}</td> </tr> <tr> <td>10</td><td>DC24V</td> <td>14</td><td>M</td> </tr> <tr> <td>11</td><td>B</td> <td>15</td><td>\bar{B}</td> </tr> <tr> <td>12</td><td>N/C</td> <td>16</td><td>\bar{N}/\bar{C}</td> </tr> </table> </div>	9	A/D	13	\bar{A}/\bar{D}	10	DC24V	14	M	11	B	15	\bar{B}	12	N/C	16	\bar{N}/\bar{C}		<p>Connection of the Switches and the Drive: Terminals 1-8</p>	<p>Connection of the Position Encoder with 5 V Differential Signals or 24 V Signals: Terminals 9-16</p>
9	A/D	13	\bar{A}/\bar{D}																
10	DC24V	14	M																
11	B	15	\bar{B}																
12	N/C	16	\bar{N}/\bar{C}																
		1: IN0	Minus limit switch	9: A / D	Track A / Data from the SSI encoder														
		5: IN1	Plus limit switch	13: /A / /D															
		2: IN2	Reducing cam; latch signal	10: 24 V DC	Power supply for the position encoder														
		6: 24 V DC	Supply for the switches	14: M															
		3: OUT0	Travel minus or rapid speed	11: B	Track B														
		7: 2L+	Load voltage infeed for OUT0, OUT1 and OUT2	15: /B															
		4: OUT1	Travel plus or creep speed	12: N / C	Track N / SSI clock (clock line)														
		8: OUT2	Rapid/creep speed and travel plus/minus	16: /N / /C															

Configuring with STEP 7 using HW Config

You begin by adapting the hardware configuration to your existing ET 200S station.

1. Open the relevant project in SIMATIC Manager.
2. Open the HW Config configuration table in your project.
3. Select 1PosUniversal (1PosU) in the hardware catalog in accordance with the position encoder (incremental encoder with 5 V differential signals, incremental encoder with 24 V signals or SSI encoder) that you use. The number 6ES7 138-4DL00-0AB0 appears in the info text. Drag the entry to the slot at which you have installed your 1PosU.
4. Double-click this number to open the "Properties for the 1PosU" dialog box.

On the Addresses tab, you will find the addresses of the slot to which you have dragged the 1PosU. Make a note of these addresses for subsequent programming.

On the Parameters tab, you will find the default settings for the 1PosU in accordance with the position encoder type selected by you. If you are not connecting any limit switches to the 1PosU, set the DI0 limit switch minus and DI1 limit switch plus parameters to "NO contact".

5. Save and compile your configuration, and download the configuration in STOP mode of the CPU by choosing "PLC -> Download to Module".

Note

Ensure that the configured position encoder type agrees with the position encoder really wired to your module and that it has been wired in accordance with the previous figure.

If this is not observed, the module can be damaged.

Integrating the FC 101 block into the user program

Integrate the following FC 101 block in your user program (in OB 1, for example). This block requires the DB1 data block with a length of 16 bytes. In the example below, the start is initiated by setting memory bit 30.0 (in the plus direction) or 30.1 (in the minus direction) with the programming device. You select rapid or creep speed using memory bit 30.2.

STL	Explanation
Block: FC101	
L PED 256	//Load feedback values from the 1PosU
T DB1.DBD8	
L PED 260	
T DB1.DBD12	
L DB1.DBB8	//Display status bits
T MB8	
L DB1.DBB12	
T MB9	

STL	Explanation
L DB1.DBD8	//Display actual value
UD DW#16#FFFFFF	
T MD12	
UN M30.0	
SPB DIRM	
L B#16#13	//Travel in plus direction
T DB1.DBB0	//(START=1, DIR_P=1, DIR_M=0, SPEED=0, TIPPEN=1)
SPA CTRL	
DIRM: UN M30.1	
SPB STOP	
L B#16#15	//Travel in minus direction
T DB1.DBB0	//(START=1, DIR_P=1, DIR_M=0, SPEED=0, TIPPEN=1)
SPA CTRL	
STOP: L B#16#0	//Stop
T DB1.DBB0	
U DB1.DBX8.2	
SPB CTRL	
UN DB1.DBX8.0	//Set/delete START depending on POS_ACK
= DB1.DBX0.0	
CTRL: U M30.2	//Set SPEED
= DB1.DBX0.3	
L DB1.DBD0	//Transfer control values to the 1PosU
T PAD256	
L DB1.DBD4	
T PAD260	

Test

Start inching mode, and monitor the associated feedback.

1. Using "Monitor/Modify Variables", check the actual value and the status bits POS_ACK, POS_ERR, POS_DONE, ERR_ENCODER and ERR_2L+.
2. Select the "Block" folder in your project. Choose the "Insert > S7 Block > Variable Table" menu command to insert the VAT 1 variable table, and then confirm with OK.
3. Open the VAT 1 variable table, and enter the following variables in the "Address" column:
 - MD12 (actual value)
 - M8.0 (POS_ACK)
 - M8.1 (POS_ERR)
 - M8.2 (POS_DONE)
 - M8.7 (ERR_ENCODER)
 - M9.7 (ERR_2L+)
 - M30.0 (inching in plus direction)
 - M30.1 (inching in minus direction)
 - M30.2 (SPEED; 0 = creep speed; 1 = rapid speed)
4. Choose "PLC > File Connect To > Configured CPU" to switch to online.
5. Choose "Variable > Monitor" to switch to monitoring.
6. Switch the CPU to RUN mode.

Result

The following table shows you which activity triggers which result.

Activity	Result
Switch the CPU to RUN mode.	<ul style="list-style-type: none"> The POS_ACK status bit is deleted The POS_ERR status bit is deleted The POS_DONE status bit is set
Check the wiring of the load voltage 2L+	
Check the feedback bit ERR_2L+	<ul style="list-style-type: none"> If ERR_2L+ = 1, correct the wiring of the load voltage 2L+
Check the encoder wiring	
Check the feedback bit ERR_ENCODER	<ul style="list-style-type: none"> If ERR_ENCODER = 1, correct the wiring of the encoder
Inching in the plus direction:	
Start inching mode in the plus direction by setting memory marker 30.0 ("Variable > Modify >")	<p>The status bit POS_ERR = 0, the UP LED lights up</p> <ul style="list-style-type: none"> The POS_ACK status bit is set The POS_DONE status bit is deleted The actual value is continuously updated The POS LED lights up The reversal of the direction of rotation you have configured and the wiring of the encoder and drive are correct <p>The status bit POS_ERR = 1, the DN LED lights up Check the reversal of the direction of rotation you have configured and the wiring of the encoder and the drive</p>
Check the speed of the drive in the plus direction	
Control the speed using memory marker 30.2 ("Variable > Modify >")	<ul style="list-style-type: none"> If the drive moves at the correct speed, your wiring is correct
Inching in the minus direction:	
Start inching mode in the plus direction by setting memory marker 30.1 ("Variable > Modify >")	<p>The status bit POS_ERR = 0, the DN LED lights up</p> <ul style="list-style-type: none"> The POS_ACK status bit is set The POS_ERR status bit is deleted The POS_DONE status bit is deleted The actual value is continuously updated The POS LED lights up The reversal of the direction of rotation you have configured and the wiring of the encoder and drive are correct <p>The status bit POS_ERR = 1, the UP LED lights up Check the reversal of the direction of rotation you have configured and the wiring of the encoder and the drive</p>
Check the speed of the drive in the minus direction	
Control the speed using memory marker 30.2 ("Variable > Modify >")	<ul style="list-style-type: none"> If the drive moves at the correct speed, your wiring is correct

3.4 Terminal Assignment Diagram

Wiring Rules

If a position encoder with 5 V differential signals is used, the wires to the terminals 9 and 13, the terminals 12 and 16, as well as at incremental encoders the wires to the terminals 11 and 15 have to be in twisted pairs and shielded.

If an incremental encoder with 24 V signal is used, the wires to the terminals 9, 11 and 12 have to be shielded.

The shield must be supported at both ends. You use the shield contact element (Order Number: 6ES7 390-5AA00-0AA0) as a shield support.

Terminal Assignment

The following table shows you the terminal assignment for the 1PosU:

Table 3- 2 Terminal Assignment of the 1PosU

Terminal Assignment	View	Remarks									
<div style="border: 1px solid black; padding: 5px;"> <p>1 POS Universal Digital</p> <p>SF □</p> <p>1 □ □ 5 UP □ □ DN 2 □ □ □ POS</p> <p>6ES7 138-4DL00-0AB0</p> <table border="0"> <tr> <td>9 A/D</td> <td>13 \bar{A}/\bar{D}</td> </tr> <tr> <td>10 DC24V</td> <td>14 M</td> </tr> <tr> <td>11 B</td> <td>15 \bar{B}</td> </tr> <tr> <td>12 N/C</td> <td>16 \bar{N}/\bar{C}</td> </tr> </table> </div>	9 A/D	13 \bar{A}/\bar{D}	10 DC24V	14 M	11 B	15 \bar{B}	12 N/C	16 \bar{N}/\bar{C}		Connection of the Switches and the Drive: Terminals 1-8	Connection of the Position Encoder with 5 V Differential Signals or 24 V Signals: Terminals 9-16
	9 A/D	13 \bar{A}/\bar{D}									
	10 DC24V	14 M									
	11 B	15 \bar{B}									
	12 N/C	16 \bar{N}/\bar{C}									
	1: IN0	Minus limit switch	9: A / D	Track A / Data from the SSI encoder							
	5: IN1	Limit switch plus	13: /A / /D								
	2: IN2	Reducing cam; latch signal	10: 24 V DC	Power supply for the position encoder							
	6: 24 V DC	Supply for the switches	14: M								
	3: OUT0	Travel minus or rapid feed	11: B	Track B							
7: 2L+	Load voltage infeed for OUT0, OUT1 and OUT2	15: /B									
4: OUT1	Travel plus or creep feed	12: N / C	Track N / SSI clock (clock line)								
8: OUT2	Rapid/creep feed and travel plus/minus	16: /N / /C									

Connection of Relays and Contactors to the Digital Outputs

Note

Direct connection of inductivities (such as relays and contactors) is possible without external circuiting. If SIMATIC output circuits can be deactivated by additionally installed contacts (for example relay contacts), you have to provide additional overvoltage protection devices at inductivities (see the following example for overvoltage protection).

Overvoltage Protection Example

The following figure shows an output circuit that requires additional overvoltage protection devices. Direct-current coils are wired with diodes or Zener diodes.

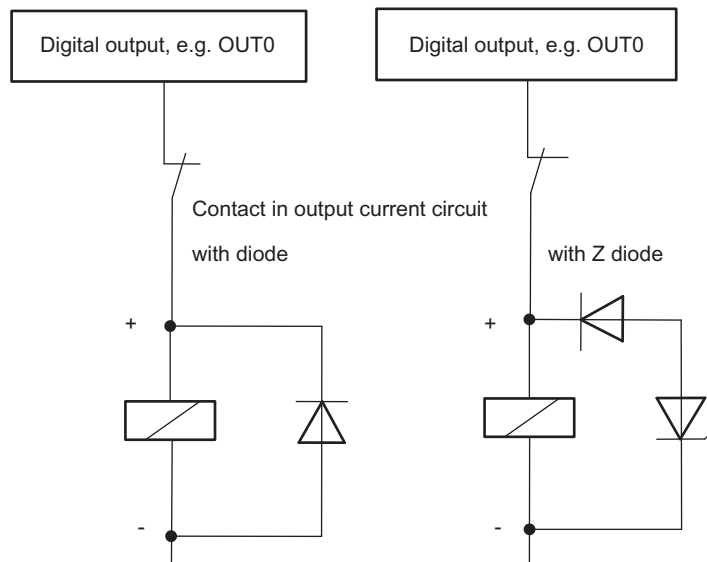

Figure 3-2 Relay Contact in the Output Circuit

3.5 Fundamentals of Controlled Positioning Using Rapid/Creep Feed

Positioning Operation

From the start position, the target is approached at high speed (rapid feed). At a preset distance from the target (switchover point), there is a change to a lower speed (creep feed). Shortly before the axis reaches the target, again at a preset distance from the target, the drive is switched off (switch-off point).

The drive is controlled via digital outputs for rapid feed or creep feed and the appropriate direction.

To facilitate understanding, the change in speed is illustrated over the path traversed.

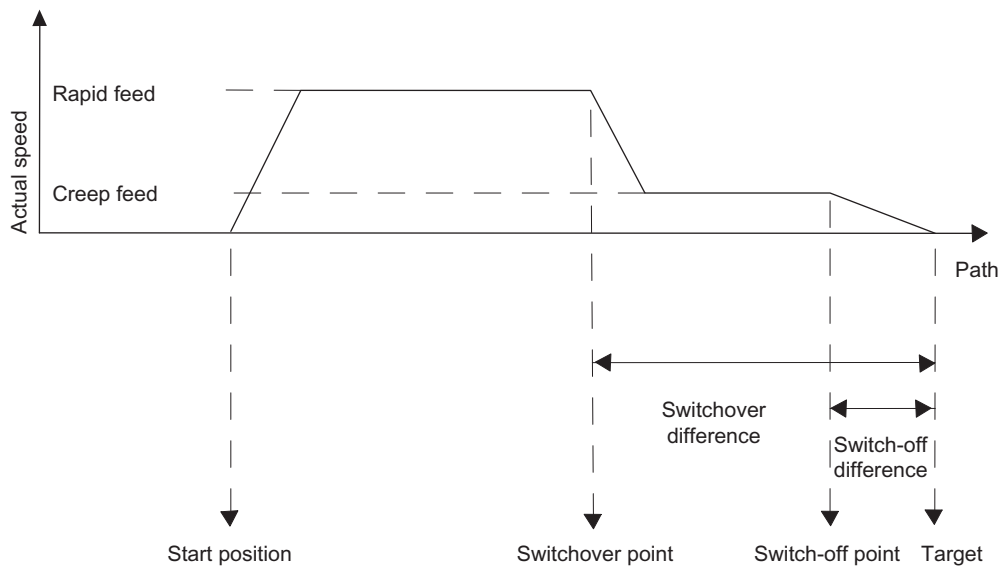

Figure 3-3 Switching points and switching differences

Definitions

Term	Explanation
Operating range	<p>Defines the range, which you set for a particular task by means of the hardware limit switches.</p> <p>At an SSI encoder the operating range is limited additionally by the range covered by the SSI encoder.</p> <p>You enter the encoder range in the parameters for:</p> <ul style="list-style-type: none"> • Number of increments • Number of rotations <p>Encoder range = Number of rotations * Number of increments</p> <p>Maximum operating range:</p> <ul style="list-style-type: none"> • Linear axis - max. 0 to (encoder range-1) • Rotary axis from 0 to (encoder range - 1) <p>At an incremental encoder the operating range is limited to:</p> <ul style="list-style-type: none"> • Max. 0 to 16,777,215 increments at a linear axis • 0 to the assigned parameter end of a rotary axis at a rotary axis
Switchover difference	Defines the distance from the destination at which the drive is switched over from rapid feed to creep feed.
Switchover point	Defines the position at which the drive is switched over from rapid feed to creep feed.
Switch-off difference	<p>Defines the distance from the destination at which the drive is switched off.</p> <p>If the switch-off difference \geq the switchover difference, there is no switchover point. There is no change from rapid feed to creep feed.</p>
Switch-off point	<p>Defines the position at which the drive is switched off.</p> <p>The 1PosU reports the end of the run at this point.</p>
Start position	<p>Defines the position of the drive within the operating range from which the run is started.</p> <p>If the start position is within the switch-off difference, the drive is not triggered. The 1PosU reports the end of the run at this point.</p> <p>If the start position is within the switchover difference, the run is only executed in creep feed mode.</p>
Target	<p>Defines the absolute or relative position of the axis approached during positioning.</p> <p>The destination is the position to be reached on an axis during a run.</p> <p>In the case of an absolute run, you specify the destination directly by means of your control program.</p> <p>In the case of a relative run, the destination is calculated from the start position and the path specified in the control program.</p> <p>If you want to find out how accurately you have reached the destination, you have to compare the actual value with the position specified.</p>
Linear axis	<p>Defines the axis type with a limited operating range.</p> <p>It is limited by the following:</p> <ul style="list-style-type: none"> • The encoder range • The numeric range that can be represented (0 to 16 777 215 increments) • The hardware limit switch

Term	Explanation
Rotary axis	Defines the axis type with an infinite operating range. This includes resetting the axis position to 0 after one rotation (assigned parameter end of a rotary axis at an incremental encoder or parameterized encoder range at an SSI encoder).
Minus direction	If the drive moves in the minus direction, the actual value displayed is decreased.
Plus direction	If the drive moves in the plus direction, the actual value displayed is increased.

3.6 Functions of the 1PosU

3.6.1 Overview of the Functions

Overview

The 1PosU offers you the following functions for moving your axis:

- Stop
- Search for Reference
- Inching
- Absolute Positioning
- Relative Positioning

In addition to the different types of motion, the 1PosU also offers functions for:

- Setting of Actual Value
- Move Encoder Range
- Change Switch-Off Difference
- Change Switchover Difference
- Reference Signal Evaluation
- Latch Function
- Setting the Monitoring of the Direction of Rotation
- Display Current Values
- Error Detection/Diagnostics
- Behavior at CPU-Master-STOP

Parameters:

Define the variables that depend on the drive, axis, and encoder uniquely in the parameters.

You can find a complete list of parameters for the 1PosU in the section "Parameter List (Page 122)".

Dosing operation:

If incremental encoders are used, the 1PosU can be used for dosing. Dosing operation is set once in the parameters. In dosing operation the 1PosU only evaluates the encoder signal A (/A). The actual value is incremented at each rising edge.

In dosing operation only the functions inching and relative positioning are available for controlling the digital outputs.

The dosing function itself is triggered by means of the relative positioning function. The dosing quantity is specified during starting by means of the control signals (distance).

At every start the actual value is set to 0 and the digital outputs are controlled as a function of the switchover and switch-off difference.

You use the parameters to select the function of the digital outputs.

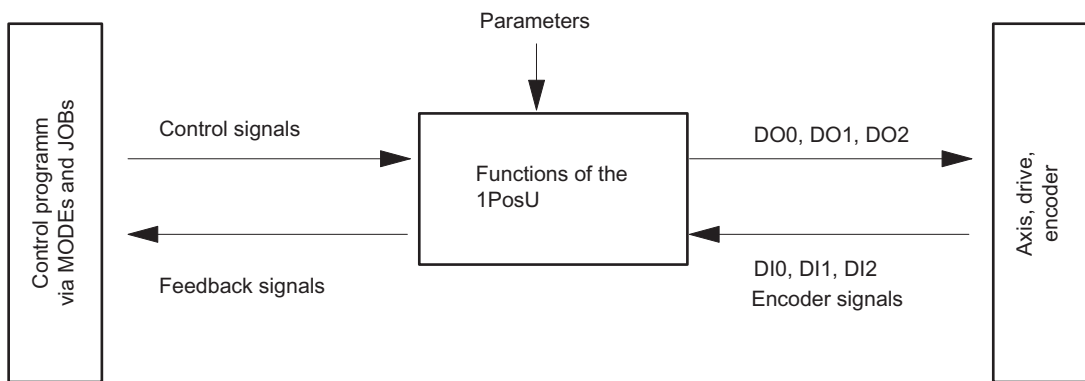

Figure 3-4 How the 1PosU Works

Interfaces to the Control Program and the Axis

To execute the function, the 1PosU has digital inputs as an interface to the axis, encoder signals for the connection to an encoder and digital outputs to control the drive.

You can modify and monitor the types of motion (MODES) and functions (JOBs) with your control program using control signals and feedback signals.

Starting MODEs

What You Do	Response of the 1PosU
Provide the control interface with data depending on the MODE. Check the POS_ACK feedback bit is at 0	
Switch the START control bit from 0 to 1	The 1PosU sets the feedback bits POS_ACK = 1 and POS_DONE = 0. You can tell by this that the start has been detected by 1PosU and when POS_ERR = 0, the MODE is executed. The MODE is not executed when POS_ERR = 1.
Switch the START control bit from 1 to 0	The 1PosU sets the feedback bit POS_ACK = 0
	In the case of stopping, the reference point run, absolute and relative positioning, the 1PosU sets the feedback bit POS_DONE = 1 when the MODE is terminated without errors. When POS_ERR = 1 the MODE is terminated with an error.
You can start a new MODE only if POS_ACK=0. If you start when a MODE is running, the 1PosU takes on the new motion and executes a change of direction, if necessary.	

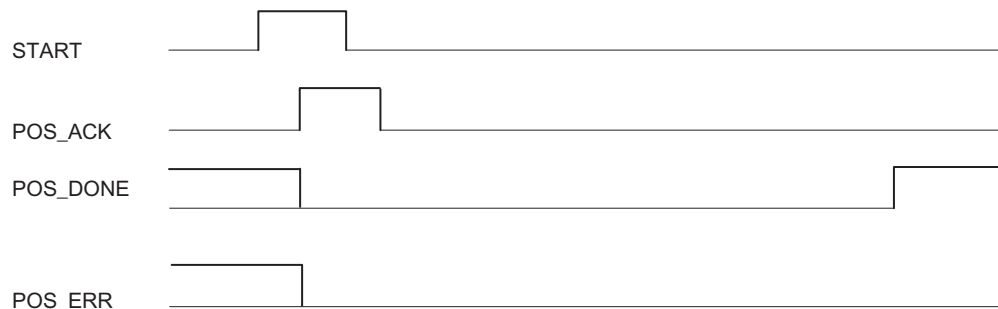

Figure 3-5 Control and Feedback Signals with MODEs

Activating JOBs

What You Do	Response of the 1PosU
Provide the control interface with data corresponding to the JOB. Check the JOB_ACK feedback bit is at 0	
Switch the JOB_REQ control bit from 0 to 1	The 1PosU sets the feedback bit JOB_ACK = 1 This indicates that the initiation of the 1PosU has been detected and that the JOB will be executed when JOB_ERR = 0. <ul style="list-style-type: none"> • In the case of the function for evaluating a reference signal, the 1PosU sets the SYNC = 0 feedback bit at the same time. • In the case of the latch function, the 1PosU sets the feedback bit LATCH_DONE = 0 at the same time. • All the other JOBs are then executed. The JOB is not executed when JOB_ERR = 1.
Switch the JOB_REQ control bit from 1 to 0	The 1PosU sets the feedback bit JOB_ACK = 0
	When a reference signal is evaluated, the 1PosU sets the feedback bit SYNC = 1 when the function has been executed. In the case of the latch function, the 1PosU sets the feedback bit LATCH_DONE = 1 when the function has been executed.
Only when JOB_ACK = 0 can you activate a new JOB again.	

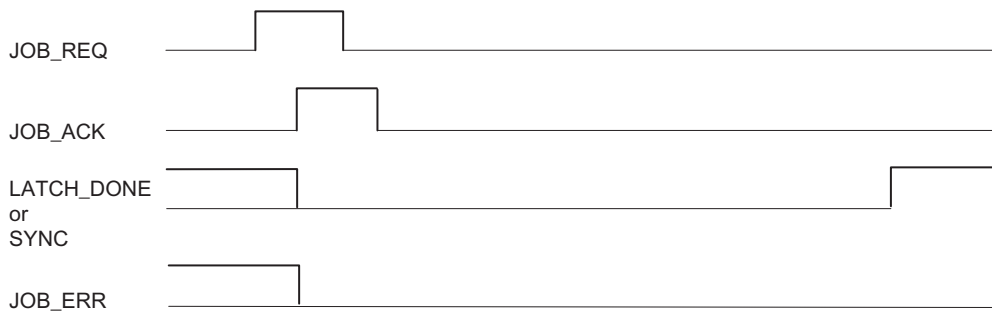

Figure 3-6 Control and Feedback Signals with JOBs

3.6.2 Axis, Drive and Encoder

Evaluation of the Encoder Signals

The 1PosU evaluates the signals supplied by the position encoder differently depending on the position encoder type:

SSI encoder:

The 1PosU evaluates the encoder value supplied by the SSI encoder directly in increments and forms the actual value in increments (actual value = encoder value).

The actual value lies in the encoder range from 0-(number of rotations * number of increments)-1. The 1PosU generates an overrun or underrun of the actual value at the limits of the operating range.

Incremental encoder:

The 1PosU evaluates the pulses supplied by the position encoder four times and adds them up direction-specifically to form the actual value. You must take the quadruple evaluation into account when you make settings for paths in the parameters and in the control and feedback interfaces:

1 pulse of the incremental encoder corresponds to 4 increments of the 1PosU.

The current value is in the operating range 0 - 16 777 215 increments. The 1PosU generates an overrun or underrun of the actual value at the limits of the operating range.

Incremental encoder at dosing operation:

The 1PosU only evaluates the rising edges of the "Track A" signal and adds them up to form the actual value.

The current value is in the operating range 0 - 16 777 215 increments. The 1PosU creates an overflow of the actual value at the upper limit of the operating range.

Reversal of the direction of rotation

You can use the parameter for the reversal of the direction of rotation to adapt the direction of rotation of the encoder to that of the drive and the axis.

In dosing operation reversal of the direction of rotation is not possible.

Controlling the Drive

The drive is controlled using the 3 digital outputs of the 1PosU.

You can select the speed with the SPEED control bit (SPEED=0 is creep feed; SPEED=1 is rapid feed). You can also change the speed during the run.

You can bring about a change in direction with the T_{min} direction change parameter.

You can read the status of each output from the feedback interface (DO0, DO1 and DO2).

The function of the digital outputs depends on the control mode.

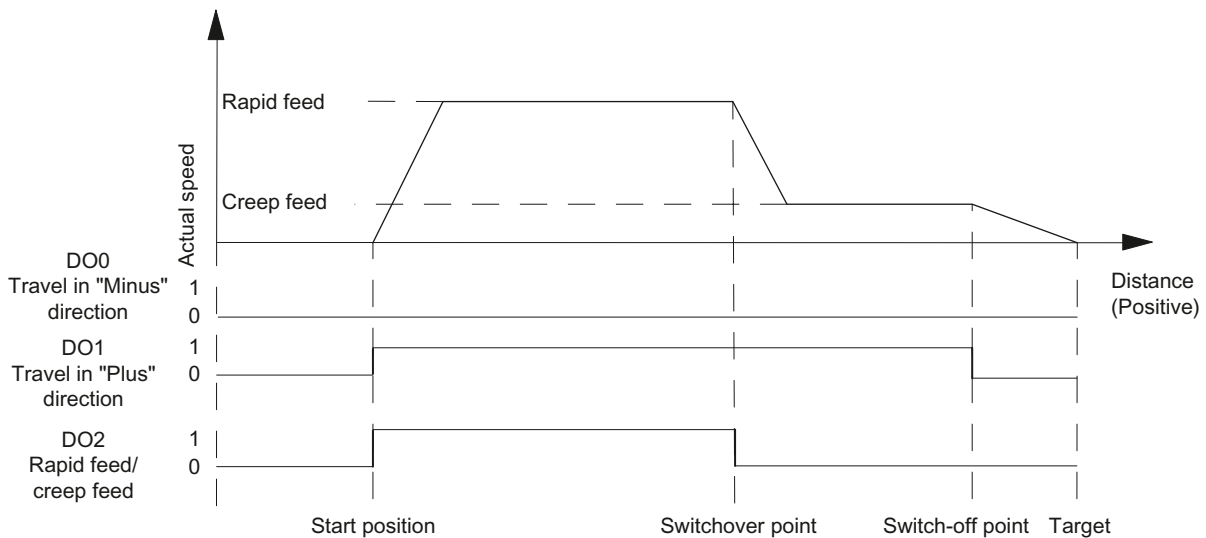

Figure 3-7 Digital Outputs with Control Mode 0

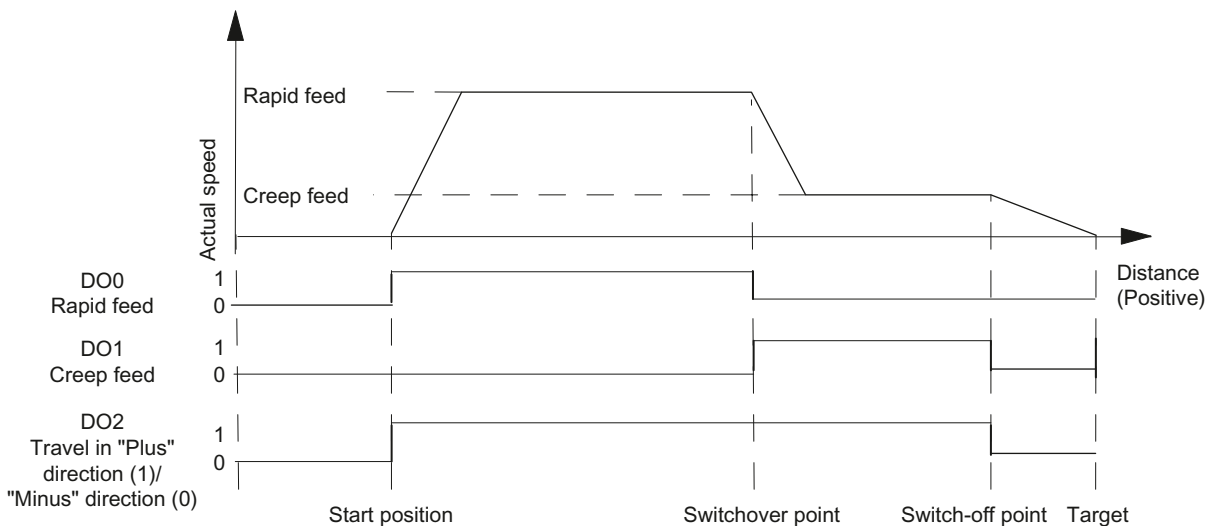

Figure 3-8 Digital Outputs with Control Mode 1

Parameters	Meaning	Value range	Default setting
Drive			
Control mode	Type 0 means: <ul style="list-style-type: none"> • DO0 travel minus • DO1 travel plus • DO2 rapid/creep feed Type 1 means: <ul style="list-style-type: none"> • DO0 rapid feed • DO1 creep feed (rapid feed is 0) • DO2 travel plus (1)/minus (0) 	<ul style="list-style-type: none"> • 0 • 1 	0
T _{min} direction change	The digital outputs are switched off, and a change of direction by T _{min} is executed with a delay. T _{min} is effective at each change of direction during a run. T _{min} is not effective at startup after POS_DONE = 1 or POS_ERR = 1. Your input value is multiplied by 10. You thus specify T _{min} in increments of 10 ms (for example, 0 ms, 10 ms or 2550 ms)	0 - 255	0

Effect of the Hardware Limit Switches

The two digital inputs (DI0 and DI1) are evaluated by the 1PosU as limit switches:

- DI0 is the minus limit switch and limits the operating range in the minus direction.
- DI1 is the plus limit switch and limits the operating range in the plus direction.

You can assign parameters to the hardware limit switches separately as break contacts or make contacts.

The hardware limit switches are evaluated with linear axes and rotary axes.

Only the hardware limit switch that lies in the direction in which the drive is being moved is evaluated.

This enables you to move away from a hardware limit switch without additional error acknowledgment by moving in the other direction if you reach or overrun a hardware limit switch.

The current signal level of the digital inputs is displayed in the feedback interface, delayed by the update rate.

You can see from the following table what effect the hardware limit switches have in the individual MODEs:

MODE	Effect of the Hardware Limit Switches
Search for Reference	The 1PosU executes an automatic reversal of direction on the hardware limit switch.
Inching	The motion of the axis is halted on the hardware limit switch, all 3 digital outputs are set to 0, and the POS_ERR feedback bit is reported.
Absolute Positioning	
Relative Positioning	

Starting on the hardware limit switch

Direction	Response of the 1PosU
Starting into the operating range	The 1PosU starts the specified MODE.
Starting away from the operating range	The POS_ERR=1 feedback bit is set.

3.6.3 Effect of the Directional Enables

Description

You enable the digital outputs directionally using the DIR_M and DIR_P control bits.

- With DIR_M = 1 you can move in the minus direction.
- With DIR_P = 1 you can move in the plus direction.

Interrupting and Continuing the Run

If you reset the relevant directional enable during a run, the motion of the axis is halted, all 3 digital outputs are set to 0, and the run is interrupted.

If you set the relevant directional enable again, the run is continued.

3.6.4 Stop (MODE 0)

Definition

If you activate MODE 0, the 1PosU stops the current run, all 3 digital outputs are set to 0, and the run is terminated (POS_ERR = 0, POS_DONE = 1).

A run terminated with MODE 0 cannot be continued. To put the axis into motion again, you start a new MODE.

Control Signals: Stop

Address	Assignment					
Byte 0	Bits 0.7 to 0.4:					
	Bit	7	6	5	4	MODE 0 = Stop
		0	0	0	0	
	Bit 0: START					

Feedback Signals: Stop

Address	Assignment
Byte 0	Bit 2: POS_DONE
	Bit 1: POS_ERR
	Bit 0: POS_ACK

3.6.5 Inching (MODE 1)

Definition

You use inching mode to control the drive directly in a particular direction using the DIR_M or DIR_P control bits.

If you start MODE 1, the 1PosU moves the drive at the preset speed (SPEED control bit) in the specified direction (control bit DIR_M or DIR_P).

You stop the drive by setting the control bits DIR_P = 0 and DIR_M = 0.

A change of direction is executed after the time T_{min} elapses.

You can also activate inching on an unsynchronized axis (feedback bit SYNC = 0) or when there is a pending encoder error (feedback bit ERR_ENCODER = 1) or without an encoder connected.

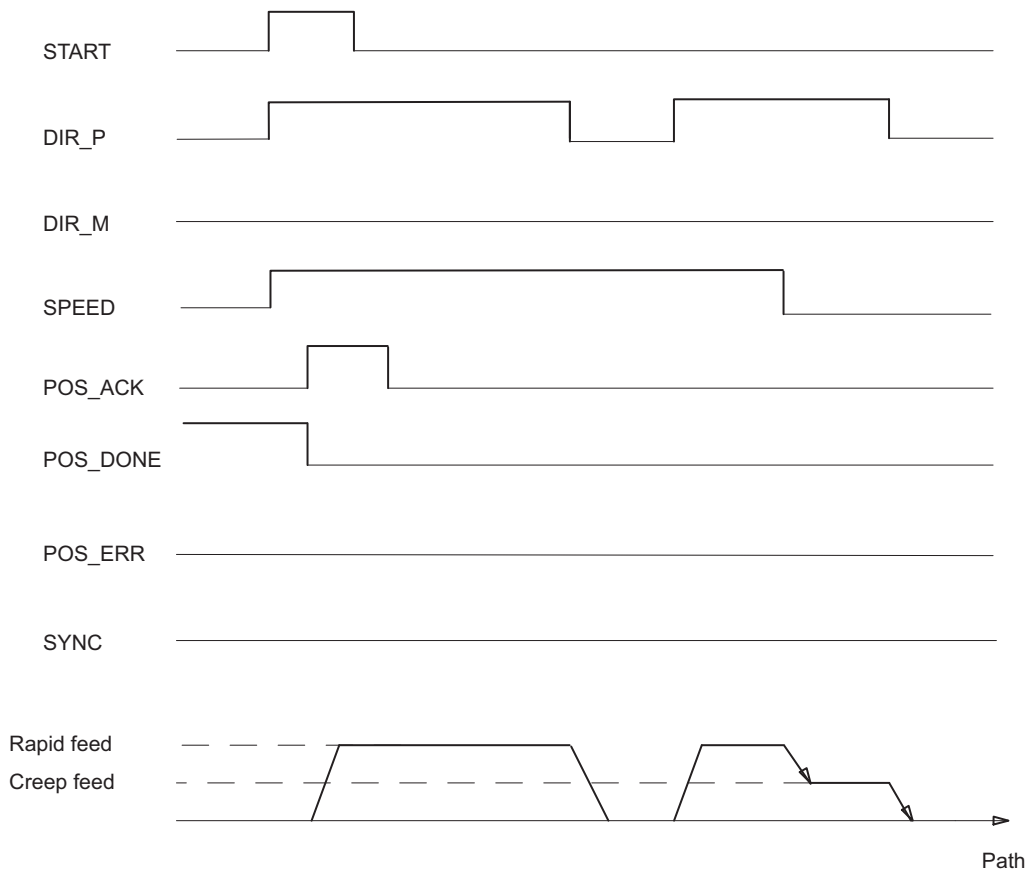

Figure 3-9 Execution of Inching

Control Signals: Inching

Address	Assignment											
Byte 0	Bits 0.7 to 0.4:											
	<table border="1"> <tr> <td>Bit</td> <td>7</td> <td>6</td> <td>5</td> <td>4</td> <td rowspan="2">MODE 1 = Inching</td> </tr> <tr> <td></td> <td>0</td> <td>0</td> <td>0</td> <td>1</td> </tr> </table>	Bit	7	6	5	4	MODE 1 = Inching		0	0	0	1
	Bit	7	6	5	4	MODE 1 = Inching						
	0	0	0	1								
Bit 3: SPEED (SPEED = 0 is creep feed; SPEED = 1 is rapid feed) Bit 2: DIR_M Bit 1: DIR_P Bit 0: START												

Feedback Signals: Inching

Address	Assignment
Byte 0	Bit 2: POS_DONE Bit 1: POS_ERR Bit 0: POS_ACK
Bytes 1 to 3	Actual value at incremental encoder (linear axis: 0 to 16 777 215; rotary axis: 0 to end of rotary axis-1) at SSI encoder (0 to encoder range - 1)

Inching: Causes of Errors for POS_ERR

You must find out the causes of errors with JOB 15 (displays current values).

Error Number	Cause	What to Do
2	ERR_2L+ is displayed	Check the load voltage (2L+) at terminal 7
5	The limit switch that lies in the direction in which the drive is moved is active	Check your switches and the wiring as well as the DI0 limit switch minus and DI1 limit switch plus parameters
7	Inching: DIR_P and DIR_M = 1	
13	Direction of rotation of the drive and the encoder varies	Check the wiring of the drive and the encoder as well as the reversal of the direction of rotation parameter
15	In dosing operation DIR_M = 1	

3.6.6 Reference Point Run (MODE 3)

Definition

A reference point run can only be started at incremental encoders and non-activated dosing operation.

You can use the reference point run to synchronize the axis on the basis of an external reference signal. You can use either the 3 digital inputs or the zero mark as a reference signal.

You can assign parameters to the digital inputs DI0 (minus limit switch) and DI1 (plus limit switch) and DI2 (reducing cam) as break or make contacts.

Provide the control interface with the reference point coordinates, and start MODE 3. The 1PosInc/Digital sets the SYNC = 0 feedback signal and moves the drive at the preset speed (SPEED control bit) in the assigned parameter start direction and searches for the reference signal. The 1PosU automatically executes the required change of direction at the limit switches and the reducing cam.

Set the necessary directional enables (DIR_M, DIR_P) to ensure that the drive is controlled.

If the 1PosU detects the assigned parameter reference signal, it controls the drive in creep feed mode in the referencing direction. This is controlled by the reference signal and reference switch parameters.

	Reference switch: Reduction cam towards minus	Reference switch: Reduction cam towards plus	Reference switch: Limit switch minus	Reference switch: Limit switch plus
Reference signal: Reference switch and zero mark	Minus referencing direction	Plus referencing direction	Plus referencing direction	Minus referencing direction
Reference signal: Reference switch				
Reference signal: Zero mark	The referencing direction is not defined. The axis is synchronized at the next zero mark.			

After the reference signal has been traversed, the axis is synchronized. The 1PosU sets the feedback signal SYNC = 1 and assigns the reference point coordinates to the actual value.

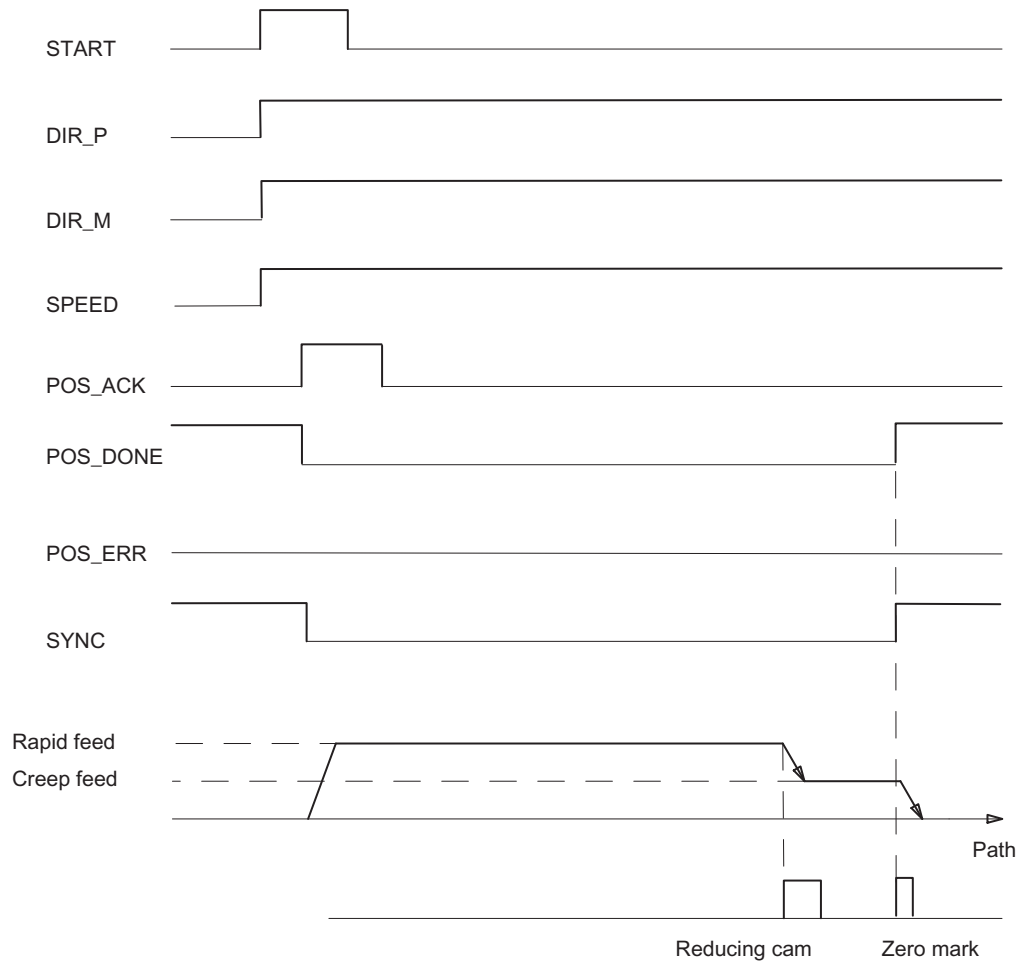

Figure 3-10 Sequence of Execution of the Search for Reference

Control Signals: Search for Reference

Address	Assignment											
Byte 0	Bits 0.7 to 0.4:											
	<table border="1"> <tr> <td>Bit</td> <td>7</td> <td>6</td> <td>5</td> <td>4</td> <td rowspan="2">MODE 3 = Reference Point Run</td> </tr> <tr> <td></td> <td>0</td> <td>0</td> <td>1</td> <td>1</td> </tr> </table>	Bit	7	6	5	4	MODE 3 = Reference Point Run		0	0	1	1
	Bit	7	6	5	4	MODE 3 = Reference Point Run						
	0	0	1	1								
Bit 3: SPEED (SPEED = 0 is creep feed; SPEED = 1 is rapid feed) Bit 2: DIR_M Bit 1: DIR_P Bit 0: START												
Bytes 1 to 3	Reference point coordinates (linear axis: 0 to 16 777 215; rotary axis: 0 to end of rotary axis - 1)											

Feedback Signals: Search for Reference

Address	Assignment
Byte 0	Bit 3: SYNC Bit 2: POS_DONE Bit 1: POS_ERR Bit 0: POS_ACK
Bytes 1 to 3	Actual value (linear axis: 0 to 16 777 215; rotary axis: 0 to end of rotary axis - 1)

Parameters: Search for Reference

Parameters	Meaning	Value range	Default setting
Reference point run and evaluation of the reference signal			
Reference signal	This parameter defines the relevant switch or the combination of switch and zero mark.	<ul style="list-style-type: none"> Reference switch and zero mark Reference switch Zero mark 	Reference switch and zero mark
Reference switch	Relevant in the case of reference signal: <ul style="list-style-type: none"> Reference switch and zero mark Reference switch This parameter defines the referencing direction in which the relevant switch must be traversed.	<ul style="list-style-type: none"> Reduction cam towards minus Reduction cam towards plus Minus limit switch Plus limit switch 	Reduction cam towards minus
Start direction of the reference point run		<ul style="list-style-type: none"> Plus Minus 	Plus

Execution of a Reference Point Run Depending on Parameterization and Start Position

In a reference point run, you have to distinguish between different cases that depend on the following:

- The start position of the drive at the start of the reference point run
- The assigned parameter start direction
- The assigned parameter reference signal
- The assigned parameter reference switch.

Example 1: Search for Reference Point Run with Reducing Cam and Zero Mark

- Start position: between the minus limit switch and the reducing cam
- Start direction: Plus
- Reference signal: Reference switch and zero mark
- Reference switch: Reduction cam towards plus

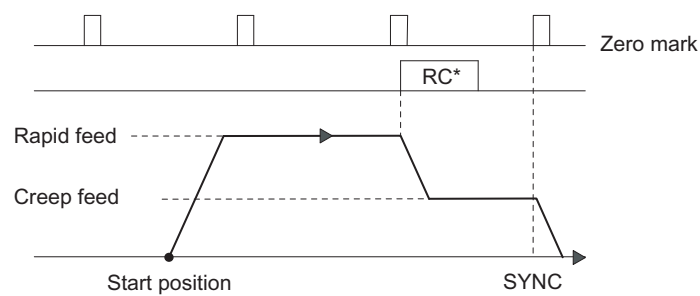

*RC = reducing cam

Figure 3-11 Search for Reference Point Run with Reducing Cam and Zero Mark

You can also carry out synchronization using the reducing cam without a zero mark.

If the start position is on the reducing cam, the 1PosU controls the drive directly in creep feed mode in the referencing direction.

Example 2: Reference Point Run with Minus Limit Switch

- Start position: between the minus limit switch and the plus limit switch
- Start direction: Minus
- Reference signal: Reference switch
- Reference switch: Minus limit switch

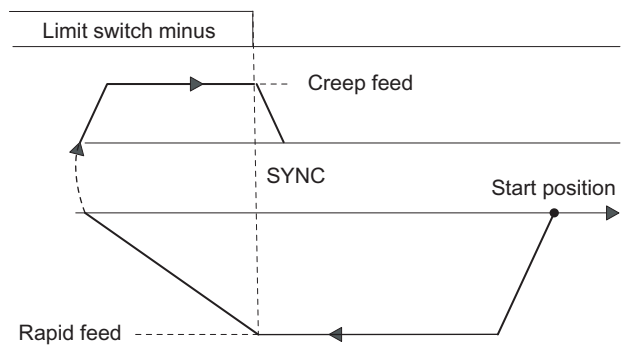

Figure 3-12 Reference Point Run with Minus Limit Switch

You can also carry out synchronization at the limit switch with the following zero mark.

If the start position is on the limit switch, the 1PosU controls the drive directly in creep feed mode in the referencing direction.

Example 3: Reference Point Run with Reversal of Direction at the Plus Limit Switch

- Start position: between the minus limit switch and the reducing cam
- Start direction: Plus
- Reference signal: Reference switch and zero mark
- Reference switch: Reduction cam towards plus

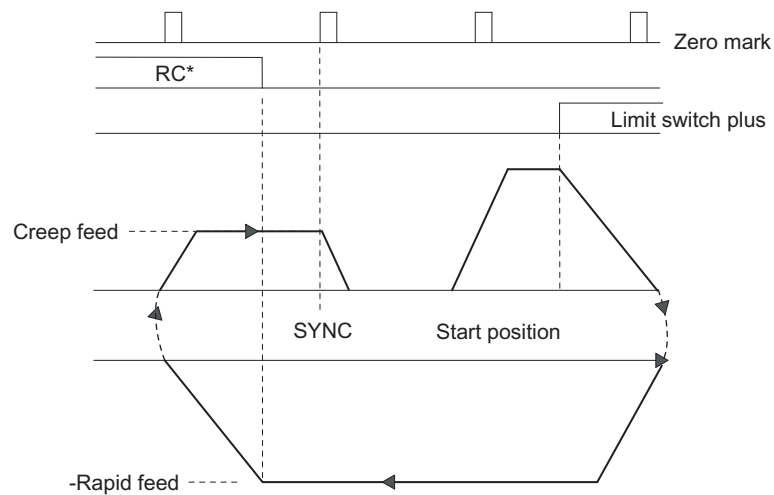

*RC = Reducing cam

Figure 3-13 Reference Point Run with Reversal of Direction at the Plus Limit Switch

If the start position is at the plus limit switch, the 1PosInc/Digital controls directly the drive in rapid feed in the opposite direction to the assigned parameter start direction.

Example 4: Reference Point Run Only with Zero Mark

- Start position: between the minus limit switch and the plus limit switch
- Start direction: Minus
- Reference signal: Zero mark
- Reference switch: irrelevant

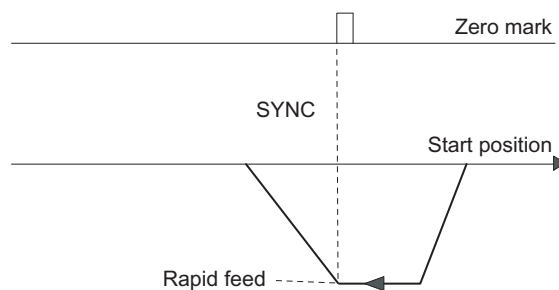

Figure 3-14 Reference Point Run Only with Zero Mark

Search for reference: Causes of Errors for POS_ERR

You must find out the causes of errors with JOB 15 (displays current values).

Error Number	Cause	What to Do
1	Impermissible MODE in dosing operation	
2	ERR_2L+ is displayed	Check the load voltage (2L+) at terminal 7
3	ERR_ENCODER is displayed	Check the encoder wiring
10	Search for reference: Reference point coordinates ≥ end of rotary axis	
11	No reference signal found up to the limit switch or between the limit switches	Check your switches, the encoder and the wiring
13	Direction of rotation of the drive and the encoder varies	Check the wiring of the drive and the encoder as well as the reversal of the direction of rotation parameter

3.6.7 Relative Positioning (MODE 4)

Definition

In relative positioning the 1PosU moves the drive from the start position in a specified direction for a certain preset distance.

Supply the control interface with the distance to be traveled, and start MODE 4, specifying the direction (DIR_M or DIR_P). The 1PosU moves the drive at the preset speed (SPEED control bit) for that distance. At the switchover point the 1PosU switches from rapid feed to creep feed, and at the switch-off it terminates the run.

If you start during an active run, the 1PosU executes the necessary change in direction after the time T_{min} has elapsed.

The preset distance is not checked by the 1PosU. This means that more than one revolution may be involved with rotary axes.

In dosing operation relative positioning is only possible in the plus direction. The actual value is set to 0 at every start.

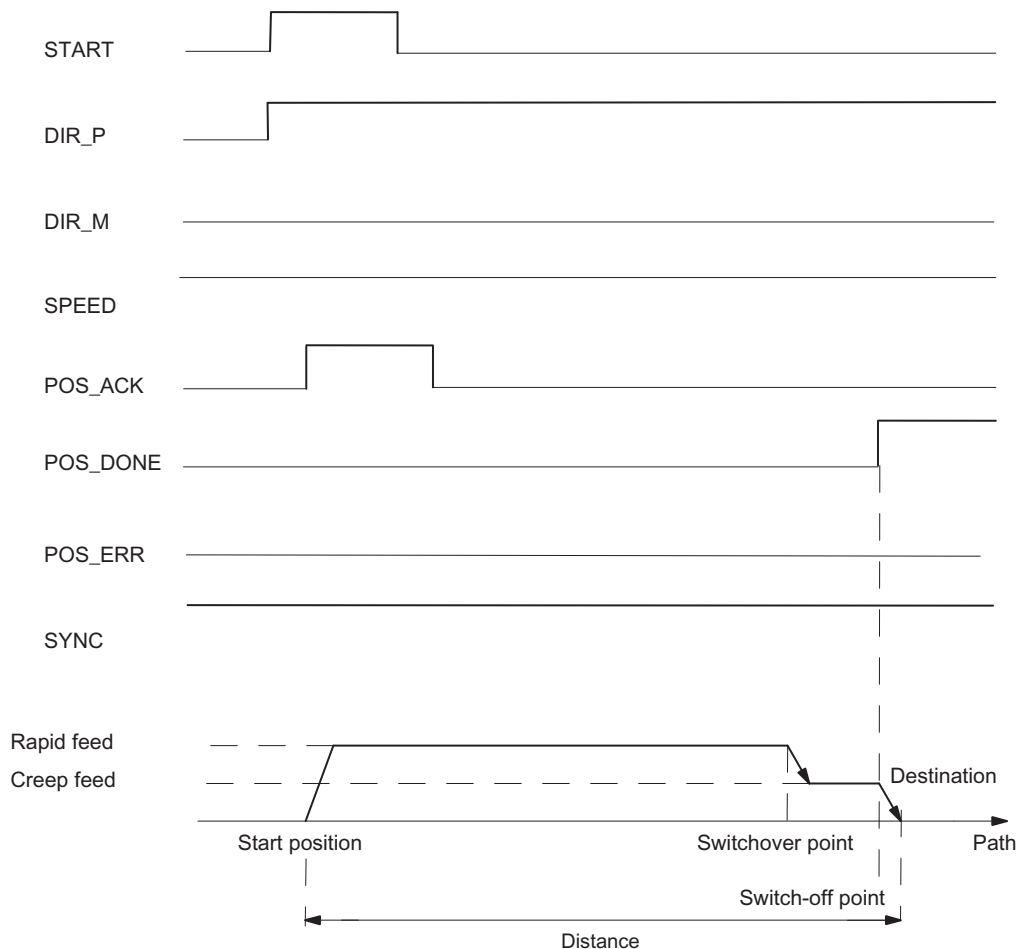

Figure 3-15 Execution of Relative Positioning

Control Signals: Relative Positioning

Address	Assignment											
Byte 0	Bits 0.7 to 0.4:											
	<table border="1"> <tr> <td>Bit</td> <td>7</td> <td>6</td> <td>5</td> <td>4</td> <td rowspan="2">MODE 4 = Relative Positioning</td> </tr> <tr> <td></td> <td>0</td> <td>1</td> <td>0</td> <td>0</td> </tr> </table>	Bit	7	6	5	4	MODE 4 = Relative Positioning		0	1	0	0
	Bit	7	6	5	4	MODE 4 = Relative Positioning						
	0	1	0	0								
Bit 3: SPEED (SPEED=0 is creep feed; SPEED=1 is rapid feed) Bit 2: DIR_M Bit 1: DIR_P Bit 0: START												
Bytes 1 to 3	Distance (linear axis: 0 to 16 777 215; rotary axis: 0...16 777 215)											

Feedback Signals: Relative Positioning

Address	Assignment
Byte 0	Bit 3: SYNC Bit 2: POS_DONE Bit 1: POS_ERR Bit 0: POS_ACK
Bytes 1 to 3	Actual value at incremental encoder (linear axis: 0 to 16 777 215; rotary axis: 0 to end of rotary axis-1), at SSI encoder (0 to encoder range - 1)

Parameters: Relative Positioning

Parameters	Meaning	Value range	Default setting
Drive			
Switch-off difference	You can change the switch-off difference with JOB 3.	0 - 65 535	100
Switchover difference	You can change the switchover difference with JOB 4.	0 - 65 535	1000

Relative Positioning: Causes of Errors for POS_ERR

You must find out the causes of errors with JOB 15 (displays current values).

Error Number	Cause	What to Do
2	ERR_2L+ is displayed	Check the load voltage (2L+) at terminal 7
3	ERR_ENCODER is displayed	Check the encoder wiring
5	The limit switch that lies in the direction in which the drive is moved is active	Check your switches and the wiring as well as the DI0 limit switch minus and DI1 limit switch plus parameters
7	Relative positioning: Start with DIR_P and DIR_M = 0 or DIR_P and DIR_M = 1	
13	Direction of rotation of the drive and the encoder varies	Check the wiring of the drive and the encoder as well as the reversal of the direction of rotation parameter
15	In dosing operation DIR_M = 1	

3.6.8 Absolute Positioning (MODE 5)

Definition

With absolute positioning, the 1PosU moves the drive toward absolute destinations. To do this, the axis must be synchronized.

Absolute positioning is not possible at activated dosing operation.

Supply the control interface with the destination, and start MODE 5 with the necessary directional enable (DIR_M, DIR_P). The 1PosU moves the drive at the preset speed (control bit SPEED) toward the destination. At the switchover point the 1PosU switches from rapid feed to creep feed, and at the switch-off it terminates the run.

If you start during an active run, the 1PosU executes the necessary change in direction after the time T_{min} has elapsed.

Linear axis

The 1PosU determines the direction the destination is to be approached from. You must set the necessary directional enable (DIR_M, DIR_P) to start. You can also set both enables.

Rotary axis

You determine the direction in which the destination is approached by selecting the directional enable (DIR_M, DIR_P):

Control bits DIR_P and DIR_M	Direction
DIR_P = 1 DIR_M = 0	The destination is approached in the plus direction.
DIR_P = 0 DIR_M = 1	The destination is approached in the minus direction.
DIR_P = 1 DIR_M = 1	The destination is approached by the shortest route. The 1PosU determines the direction the destination is to be approached from. If the resulting distance to be traveled is smaller than the switch-off difference, no run is started (POS_DONE = 1).

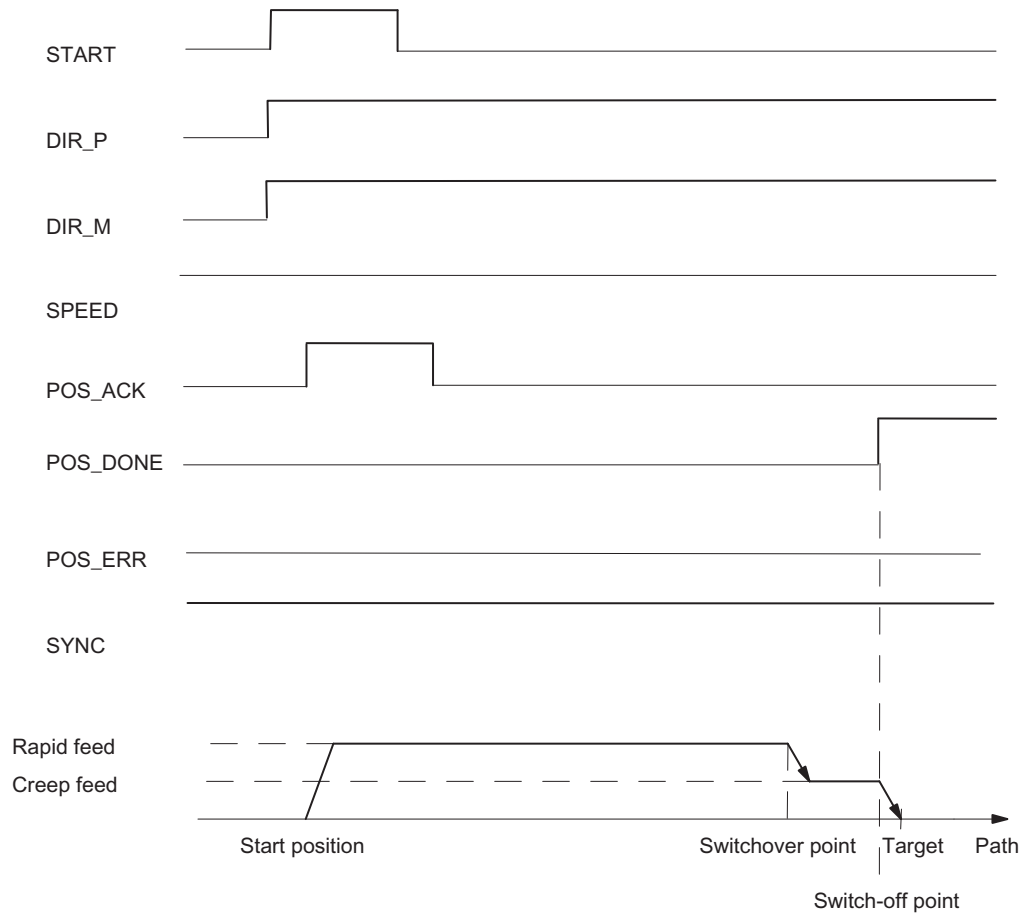

Figure 3-16 Execution of Absolute Positioning

Control Signals: Absolute Positioning

Address	Assignment											
Byte 0	Bits 0.7 to 0.4:											
	<table border="1"> <tr> <td>Bit</td> <td>7</td> <td>6</td> <td>5</td> <td>4</td> <td rowspan="2">MODE 5 = Absolute Positioning</td> </tr> <tr> <td></td> <td>0</td> <td>1</td> <td>0</td> <td>1</td> </tr> </table>	Bit	7	6	5	4	MODE 5 = Absolute Positioning		0	1	0	1
	Bit	7	6	5	4	MODE 5 = Absolute Positioning						
	0	1	0	1								
Bit 3: SPEED (SPEED = 0 is creep feed; SPEED = 1 is rapid feed) Bit 2: DIR_M Bit 1: DIR_P Bit 0: START												
Bytes 1 to 3	target at incremental encoder (linear axis: 0 to 16 777 215; rotary axis: 0 to end of rotary axis-1), at SSI encoder (0 to encoder range - 1)											

Feedback Signals: Absolute Positioning

Address	Assignment
Byte 0	Bit 3: SYNC Bit 2: POS_DONE Bit 1: POS_ERR Bit 0: POS_ACK
Bytes 1 to 3	Actual value at incremental encoder (linear axis: 0 to 16 777 215; rotary axis: 0 to end of rotary axis-1), at SSI encoder (0 to encoder range - 1)

Parameters: Absolute Positioning

Parameters	Meaning	Value range	Default setting
Drive			
Switch-off difference	You can change the switch-off difference with JOB 3.	0 - 65 535	100
Switchover difference	You can change the switchover difference with JOB 4.	0 - 65 535	1000

Absolute positioning: Causes of Errors for POS_ERR

You must find out the causes of errors with JOB 15 (displays current values).

Error Number	Cause	What to Do
1	Impermissible MODE in dosing operation	
2	ERR_2L+ is displayed	Check the load voltage (2L+) at terminal 7
3	ERR_ENCODER is displayed	Check the encoder wiring
4	The axis is not synchronized (SYNC=0)	You can synchronize the axis with: <ul style="list-style-type: none"> • Reference point run • Reference Signal Evaluation • Setting of Actual Value
5	The limit switch that lies in the direction in which the drive is moved is active	Check your switches and the wiring as well as the DI0 limit switch minus and DI1 limit switch plus parameters
7	Start with DIR_P and DIR_M = 0 or relevant control bit DIR_P or DIR_M = 0	
8	Destination \geq end of rotary axis (at incremental encoders) or destination \geq encoder range (at SSI encoders)	

Error Number	Cause	What to Do
9	Absolute positioning was terminated because JOB 9 was initiated (only at incremental encoders)	
13	Direction of rotation of the drive and the encoder varies	Check the wiring of the drive and the encoder as well as the reversal of the direction of rotation parameter

3.6.9 Canceling JOB Processing (JOB 0)

Definition

If you activate JOB 0, the 1PosU responds as follows:

- It cancels the current JOB 9 (reference signal evaluation)
- It cancels the current JOB 10 (latch function)
- It sets a pending JOB_ERR = 0.

You can activate JOB 0 whatever the state of the axis.

Effect on the MODEs

MODEs are not affected by JOB 0.

Control Signals: Canceling JOB processing

Address	Assignment												
Byte 4	Bits 4.7 to 4.4 :												
	<table border="1"> <thead> <tr> <th>Bit</th> <th>7</th> <th>6</th> <th>5</th> <th>4</th> <th></th> </tr> </thead> <tbody> <tr> <td></td> <td>0</td> <td>0</td> <td>0</td> <td>0</td> <td>JOB 0 = Cancel JOB processing</td> </tr> </tbody> </table>	Bit	7	6	5	4			0	0	0	0	JOB 0 = Cancel JOB processing
	Bit	7	6	5	4								
	0	0	0	0	JOB 0 = Cancel JOB processing								
Bit 0: JOB_REQ													

Feedback Signals: Canceling JOB processing

Address	Assignment
Byte 4	Bit 1: JOB_ERR
	Bit 0: JOB_ACK

3.6.10 Setting the Actual Value (JOB 1)

Definition

Setting an actual value assigns new coordinates to the actual value displayed. This moves the operating range to another part of the axis.

The axis is synchronized at incremental encoders and non-activated dosing operation.

Assign new actual value coordinates to the interface and activate JOB 1.

The 1PosU sets the preset actual value coordinates to the actual value displayed in the feedback interface and sets the feedback bit SYNC = 1.

Effect on the MODEs

MODE	What happens ...
Reference point approach	At incremental encoders and non-activated dosing operation ensure when the reference point run is evaluated that the feedback bit SYNC = 1 is set immediately. The reference point run still continues to run.
Inching	-
Absolute Positioning	The following responses are possible: <ul style="list-style-type: none"> Distance to the destination \leq switch-off difference The switch-off point is reached or overshoot; positioning is switched off immediately, and the run is terminated with POS_DONE = 1. In this case, the destination is sometimes overshoot. Distance to the destination \leq the switchover difference The switchover point is reached or overshoot; there is an immediate reduction from rapid feed to creep feed. In this case the distance covered in creep feed is less than (switchover difference - switch-off difference). Distance to the destination $>$ the switchover difference The drive is moved using rapid feed, even if it was switched over to creep feed beforehand.
Relative Positioning	The preset distance continues to be traversed.

Control Signals: Setting of Actual Value

Address	Assignment											
Byte 4	Bit 4.7 to 4.4:											
	<table border="1"> <tr> <td>Bit</td> <td>7</td> <td>6</td> <td>5</td> <td>4</td> <td rowspan="2">JOB 1 = Set the actual value</td> </tr> <tr> <td></td> <td>0</td> <td>0</td> <td>0</td> <td>1</td> </tr> </table>	Bit	7	6	5	4	JOB 1 = Set the actual value		0	0	0	1
	Bit	7	6	5	4	JOB 1 = Set the actual value						
	0	0	0	1								
Bit 0: JOB_REQ												
Bytes 5 to 7	Actual value coordinates at incremental encoder (linear axis: 0 to 16 777 215; rotary axis: 0 to end of rotary axis-1), at SSI encoder (0 to encoder range - 1)											

Feedback Signals: Setting of Actual Value

Address	Assignment
Byte 0	Bit 3: SYNC
Bytes 1 to 3	Actual value at incremental encoder (linear axis: 0 to 16 777 215; rotary axis: 0 to end of rotary axis-1), at SSI encoder (0 to encoder range - 1)
Byte 4	Bit 1: JOB_ERR Bit 0: JOB_ACK

Setting an Actual Value: Causes of Errors for JOB_ERR

Error Number	Meaning	What to Do
23	ERR_ENCODER is displayed	Check the encoder wiring
34	Actual-value coordinates \geq end of rotary axis (at incremental encoders) or actual-value coordinates \geq encoder range (at SSI encoders)	

3.6.11 Moving the Encoder Range (JOB 2)

Definition

The move encoder range function can only be executed at SSI encoders.

When the encoder range is moved, the encoder value is adjusted so that the actual value displayed corresponds to the real actual value. Before this can be done, any active run must be terminated.

Supply the control interface with the offset, and activate JOB 2.

You calculate the offset as follows:

- Offset = displayed actual value – real actual value

If the offset is negative, proceed as follows:

- Offset = displayed actual value - real actual value + (number of rotations * number of increments)

The 1PosU accepts the preset offset and displays the real actual value coordinates at the feedback interface.

Effect on the MODEs

MODEs are not affected by JOB 2.

Control Signals: Move Encoder Range

Address	Assignment											
Byte 4	Bits 4.7 to 4.4 :											
	<table border="1"> <tr> <td>Bit</td> <td>7</td> <td>6</td> <td>5</td> <td>4</td> <td rowspan="2">JOB 2 = Move encoder range</td> </tr> <tr> <td></td> <td>0</td> <td>0</td> <td>1</td> <td>0</td> </tr> </table>	Bit	7	6	5	4	JOB 2 = Move encoder range		0	0	1	0
	Bit	7	6	5	4	JOB 2 = Move encoder range						
	0	0	1	0								
Bit 0: JOB_REQ												
Bytes 5 to 7	Offset (0 to encoder range)											

Feedback Signals: Move Encoder Range

Address	Assignment
Bytes 1 to 3	Actual value (0 to encoder range - 1)
Byte 4	Bit 1: JOB_ERR
	Bit 0: JOB_ACK

Move Encoder Range: Causes of Errors for JOB_ERR

Error Number	Meaning	What to Do
21	Invalid JOB at incremental encoder	
23	ERR_ENCODER is displayed	Check the encoder wiring
26	JOB 2 (move encoder range) cannot be initiated because there is an active run	
33	With JOB 2: Offset not in encoder range	

3.6.12 Changing the Switch-Off Difference (JOB 3)

Definition

Changing the switch-off difference allows you to adjust the drive control to adapt to any changes in the load and mechanical conditions.

Supply the control interface with the new switch-off difference, and activate JOB 3.

The 1PosU accepts the specified switch-off difference.

The switch-off difference remains valid until the parameter assignment of the 1PosU is changed (see section "CPU/Master Stop and RESET State (Page 121)").

Effect on the MODEs

MODE	What happens ...
Search for Reference	-
Inching	
Absolute Positioning	Distance to the destination \leq switch-off difference The switch-off point is reached or overshot; positioning is switched off immediately, and the run is terminated with POS_DONE = 1. In this case, the destination is sometimes overshot.
Relative Positioning	

Control Signals: Change Switch-Off Difference

Address	Assignment											
Byte 4	Bit 4.7 to 4.4:											
	<table border="1"> <tr> <td>Bit</td> <td>7</td> <td>6</td> <td>5</td> <td>4</td> <td rowspan="2">JOB 3 = Change the switch-off difference</td> </tr> <tr> <td></td> <td>0</td> <td>0</td> <td>1</td> <td>1</td> </tr> </table>	Bit	7	6	5	4	JOB 3 = Change the switch-off difference		0	0	1	1
	Bit	7	6	5	4	JOB 3 = Change the switch-off difference						
	0	0	1	1								
Bit 0: JOB_REQ												
Bytes 5 to 7	Switch-off difference (linear axis: 0 to 16 777 215; rotary axis: 0...16 777 215)											

Feedback Signals: Change Switch-Off Difference

Address	Assignment
Byte 4	Bit 0: JOB_ACK

3.6.13 Changing the Switchover Difference (JOB 4)

Definition

Changing the switchover difference allows you to adjust the drive control to adapt to any changes in the load and mechanical conditions.

Supply the control interface with the new switchover difference, and activate JOB 4.

The 1PosU accepts the specified switchover difference.

The switchover difference remains valid until the parameter assignment (see section "CPU/Master Stop and RESET State (Page 121)") of the 1PosU is changed.

Effect on the MODEs

MODE	What happens ...
Search for Reference	-
Inching	
Absolute Positioning	The following responses are possible: <ul style="list-style-type: none"> Distance to the destination \leq the switchover difference. The switchover point is reached or overshoot; there is an immediate reduction from rapid feed to creep feed. In this case the distance covered in creep feed is less than (switchover difference - switch-off difference). Distance to the destination $>$ the switchover difference The drive is moved using rapid feed, even if it was switched over to creep feed beforehand.
Relative Positioning	

Control Signals: Change Switchover Difference

Address	Assignment												
Byte 4	Bit 4.7 to 4.4:												
	<table border="1"> <thead> <tr> <th>Bit</th> <th>7</th> <th>6</th> <th>5</th> <th>4</th> <th></th> </tr> </thead> <tbody> <tr> <td></td> <td>0</td> <td>1</td> <td>0</td> <td>0</td> <td>JOB 4 = Change the switchover difference</td> </tr> </tbody> </table>	Bit	7	6	5	4			0	1	0	0	JOB 4 = Change the switchover difference
	Bit	7	6	5	4								
	0	1	0	0	JOB 4 = Change the switchover difference								
Bit 0: JOB_REQ													
Bytes 5 to 7	Switchover difference (linear axis: 0 to 16 777 215; rotary axis: 0...16 777 215)												

Feedback Signals: Change Switchover Difference

Address	Assignment
Byte 4	Bit 0: JOB_ACK

3.6.14 Evaluating the Reference Signal (JOB 9)

Definition

The evaluate reference signal function is only available at incremental encoders and non-active dosing operation.

By evaluating the reference signal you can synchronize the axis using an external reference signal during a current run in inching or relative positioning mode. You can use either the 3 digital inputs or the zero mark as a reference signal.

You can assign parameters to the digital inputs DI0 (minus limit switch) and DI1 (plus limit switch) and DI2 (reducing cam) as break or make contacts.

Supply the control interface with the reference point coordinates, and activate JOB 9. The 1PosU sets the feedback signal SYNC = 0.

If the 1PosInc/Digital detects the overrunning of the assigned parameter reference signal in the referencing direction, the axis is synchronized. The 1PosU sets the feedback signal SYNC = 1 and assigns the reference point coordinates to the actual value.

The referencing direction is determined by the reference signal and reference switch parameters.

	Reference switch: Reduction cam towards minus	Reference switch: Reduction cam towards plus	Reference switch: Limit switch minus	Reference switch: Limit switch plus
Reference signal: Reference switch and zero mark	Minus referencing direction	Plus referencing direction	Plus referencing direction	Minus referencing direction
Reference signal: Reference switch				
Reference signal: Zero mark	The referencing direction is not defined. The axis is synchronized at the next zero mark.			

Effect on the MODEs

MODE	What Happens
Search for Reference	The reference coordinates transferred with JOB 9 are valid
Inching	-
Absolute Positioning	Run canceled with POS_ERR = 1 because SYNC is deleted
Relative Positioning	-

Control Signals: Reference Signal Evaluation

Address	Assignment											
Byte 4	Bits 4.7 to 4.4 :											
	<table border="1" style="display: inline-table; vertical-align: middle;"> <tr> <td>Bit</td> <td>7</td> <td>6</td> <td>5</td> <td>4</td> <td rowspan="2">JOB 9 = Evaluate the reference signal</td> </tr> <tr> <td></td> <td>1</td> <td>0</td> <td>0</td> <td>1</td> </tr> </table>	Bit	7	6	5	4	JOB 9 = Evaluate the reference signal		1	0	0	1
	Bit	7	6	5	4	JOB 9 = Evaluate the reference signal						
	1	0	0	1								
Bit 0: JOB_REQ												
Bytes 5 to 7	Reference point coordinates (linear axis: 0 to 16 777 215; rotary axis: 0 to end of rotary axis - 1)											

Feedback Signals: Reference Signal Evaluation

Address	Assignment
Byte 0	Bit 3: SYNC
Bytes 1 to 3	Actual value (linear axis: 0 to 16 777 215; rotary axis: 0 to end of rotary axis - 1)
Byte 4	Bit 1: JOB_ERR
	Bit 0: JOB_ACK

Parameters: Reference Signal Evaluation

Parameters	Meaning	Value range	Default setting
Reference point run and evaluation of the reference signal			
Reference signal	This parameter defines the relevant switch or the combination of switch and zero mark.	<ul style="list-style-type: none"> • Reference switch and zero mark • Reference switch • Zero mark 	Reference switch and zero mark
Reference switch	Relevant in the case of reference signal: <ul style="list-style-type: none"> • Reference switch and zero mark • Reference switch This parameter defines the referencing direction in which the switch must be traversed.	<ul style="list-style-type: none"> • Reduction cam towards minus • Reduction cam towards plus • Minus limit switch • Plus limit switch 	Reduction cam towards minus

Evaluating the Reference Signal: Causes of Errors for JOB_ERR

Error Number	Meaning	What to Do
21	Impermissible JOB at SSI encoders or in dosing operation	
23	ERR_ENCODER is displayed	Check the encoder wiring
30	Reference point coordinates \geq end of rotary axis	

3.6.15 Latch Function (JOB 10)

Definition

The latch function allows you to store the actual value at an edge at the DI2 digital input. You can use this function, for example, to detect edges or measure lengths.

Supply the control interface with the desired edge, and activate JOB 10.

If the 1PosU detects the preset edge at the DI2 digital input, it stores the associated actual value, displays it as a feedback value and sets the feedback bit LATCH_DONE = 1.

You can then activate the latch function again.

Latch Function and Reference Point Run or Reference Signal

If the 1PosU synchronizes at the same edge, it stores the actual value before it assigns the reference point coordinates.

Effect on the MODEs

MODEs are not affected by JOB 10.

Control Signals: Latch Function

Address	Assignment											
Byte 4	Bits 4.7 to 4.4 :											
	<table border="1"> <tr> <td>Bit</td> <td>7</td> <td>6</td> <td>5</td> <td>4</td> <td rowspan="2">JOB 10 = Latch function</td> </tr> <tr> <td></td> <td>1</td> <td>0</td> <td>1</td> <td>0</td> </tr> </table>	Bit	7	6	5	4	JOB 10 = Latch function		1	0	1	0
	Bit	7	6	5	4	JOB 10 = Latch function						
	1	0	1	0								
Bit 0: JOB_REQ												
Byte 5	Bit 1: Latch at negative edge at DI2											
	Bit 0: Latch at positive edge at DI2											

Feedback Signals: Latch Function

Address	Assignment
Byte 4	Bit 2: LATCH_DONE
	Bit 1: JOB_ERR
	Bit 0: JOB_ACK
Bytes 5 to 7	Feedback value: Actual value at the edge at DI2 for incremental encoder (linear axis: 0 to 16 777 215; rotary axis: 0 to end of rotary axis-1), at SSI encoder (0 to encoder range - 1)

Latch Function: Causes of Errors for JOB_ERR

Error Number	Meaning	What to Do
23	ERR_ENCODER is displayed	Check the encoder wiring
36	Edge selection unknown	

3.6.16 Setting the Monitoring of the Direction of Rotation (JOB 11)

Definition

The monitoring of the direction of rotation function is not available in dosing operation.

By setting monitoring of the direction of rotation you can adjust the monitoring of the direction of rotation of the 1PosU to suit your load and mechanical conditions.

Monitoring of the direction of rotation is always active. The 1PosU detects whether the direction of rotation of the drive and the encoder is the same. Direction of rotation monitoring will tolerate different directions for the drive and the encoder up to the preset path difference. If the preset path difference is exceeded, the 1PosU reports POS_ERR =1 (see section "Displaying Current Values (JOB 15) (Page 112)").

Unless you have activated JOB 11, double the switch-off difference is used from the parameters as the path difference. JOB 3 (which changes the switch-off difference) does not affect the path difference for the purpose of monitoring of the direction of rotation.

Supply the control interface with the new path difference, and activate JOB 11.

The 1PosU accepts the preset path difference for the monitoring of the direction of rotation.

The path difference for the direction-of-rotation monitoring remains valid until the parameter assignment (see section "CPU/Master Stop and RESET State (Page 121)") of the 1PosU is changed.

Disabling the Monitoring of the Direction of Rotation

Monitoring of the direction of rotation is disabled when the path difference is 0.

Effect on the MODEs

MODEs are not affected by JOB 11.

Control Signals: Setting the Monitoring of the Direction of Rotation

Address	Assignment					
Byte 4	Bit 4.7 to 4.4:					
	Bit	7	6	5	4	JOB 11 = Set the monitoring of the direction of rotation
		1	0	1	1	
	Bit 0: JOB_REQ					
Byte 5	0					
Bytes 6, 7	Path difference for monitoring of the direction of rotation (0 to 65 535)					

Feedback Signals: Setting the Monitoring of the Direction of Rotation

Address	Assignment
Byte 4	Bit 1: JOB_ERR Bit 0: JOB_ACK

Setting the Monitoring of the Direction of Rotation: Causes of Errors for JOB_ERR

Error Number	Meaning	What to Do
21	Impermissible JOB in dosing operation	
38	Monitoring of the direction of rotation path difference > 65 535	

3.6.17 Displaying Current Values (JOB 15)

Definition

You can display the following values in the feedback interface as feedback values:

- Residual distance
- Actual speed
- Causes of errors for POS_ERR and JOB_ERR

The residual distance is set by the 1PosU as the default for the feedback value.

The 1PosU continuously displays the actual value in the feedback interface irrespective of the selected feedback value.

Supply the control interface with the desired feedback value and activate JOB 15.

The selected feedback value remains valid until the parameter assignment (see section "CPU/Master Stop and RESET State (Page 121)") of the 1PosU is changed.

Displaying Current Values and the Latch Function

If you activate the latch function, the 1PosU sets a feedback value of 0 and displays the actual value at the edge at the DI2 digital input.

You can only activate JOB 15 again after the latch function has terminated.

Residual distance

The 1PosU calculates the distance to the destination as the residual distance in the absolute positioning and relative positioning MODEs. As long as the actual value is before the destination, the residual distance remains positive. It becomes negative once the destination is overshoot. The residual distance is 0 in the other MODEs.

The 1PosU displays the residual distance with a sign between -8 388 608 and 8 388 607 increments. Negative values are displayed in twos complement. If the actual residual distance is beyond these limits, the limit value is displayed.

Actual speed

The 1PosU calculates the actual speed as an encoder value change in increments per 10 ms. It displays these between 0 and 16 777 215.

Causes of errors for POS_ERR and JOB_ERR

The 1PosU displays the causes of errors for POS_ERR and JOB_ERR as well as the MODE and JOB entered in the control interface.

Effect on the MODEs

MODEs are not affected by JOB 15.

Control Signals: Display Current Values

Address	Assignment											
Byte 4	Bit 4.7 to 4.4:											
	<table border="1"> <tr> <td>Bit</td> <td>7</td> <td>6</td> <td>5</td> <td>4</td> <td rowspan="2">JOB 15 = Display current values</td> </tr> <tr> <td></td> <td>1</td> <td>1</td> <td>1</td> <td>1</td> </tr> </table>	Bit	7	6	5	4	JOB 15 = Display current values		1	1	1	1
	Bit	7	6	5	4	JOB 15 = Display current values						
	1	1	1	1								
Bit 0: JOB_REQ												
Byte 5	0: Residual distance 1: Actual speed 2: Causes of errors for POS_ERR and JOB_ERR											

Feedback Signals: Display Current Values

Address	Assignment
Byte 4	Bit 1: JOB_ERR Bit 0: JOB_ACK
Bytes 5 to 7	In accordance with the selected feedback value: <ul style="list-style-type: none"> • With a residual distance of: - 8 388 608...8 388 607 • With an actual speed of: 0...16 777 215 • With causes of errors for POS_ERR and JOB_ERR <ul style="list-style-type: none"> – Byte 5: Causes of error for POS_ERR (see section "Error Detection/Diagnostics (Page 114)") – Byte 6: Causes of error for JOB_ERR (see section "Error Detection/Diagnostics (Page 114)") – Bit 7.3 to 7.0: MODE (= bits 0.7 to 0.4 from the control signals) – Bit 7.7 to 7.4: JOB (= bits 4.7 to 4.4 from the control signals)

Display current values: Causes of Errors for JOB_ERR

Error Number	Meaning	What to Do
35	Display current values: Selection unknown	
37	Display current values: JOB 15 cannot be activated with the latch function running.	

3.6.18 Error Detection/Diagnostics

Parameter assignment error

Parameter assignment error	Response of the 1PosU
<p>Causes:</p> <ul style="list-style-type: none"> • The 1PosU cannot identify existing parameters as its own. • The slot of the 1PosU you have configured does not match the setup. <p>Only at SSI encoder:</p> <ul style="list-style-type: none"> • Impermissible value for parameter for number of increments. • Impermissible value for parameter for number of rotations. • Number of increments * number of rotations is greater than 4096x4096. <p>Only for dosing operation:</p> <ul style="list-style-type: none"> • Activated "Encoder signal" diagnostics • Activated "Reversal of the direction of rotation" <p>What to Do:</p> <ul style="list-style-type: none"> • Check the configuration and setup 	<ul style="list-style-type: none"> • The 1PosU is not assigned parameters and cannot execute its functions. • Generating channel-specific diagnostics

External Errors

Load Voltage 2L+ Missing	Response of the 1PosU
<p>Causes:</p> <ul style="list-style-type: none"> • Load voltage 2L+ not present or too low at terminal 7 <p>What to Do:</p> <ul style="list-style-type: none"> • Check the wiring and correct the short circuit. • Acknowledge the error with the EXTf_ACK control bit. 	<ul style="list-style-type: none"> • The current run is halted; it is not possible to start a new run. <ul style="list-style-type: none"> – All 3 digital outputs are set to 0. – Feedback bit POS_ERR = 1 – Feedback bit POS_DONE = 0 • Feedback bit ERR_2L+ = 1 • Generating channel-specific diagnostics • Waits for error acknowledgment EXTf_ACK
Short circuit of the encoder supply	Response of the 1PosU
<p>Causes:</p> <ul style="list-style-type: none"> • Short circuit of the encoder supply made available at terminals 6 and 10 <p>What to Do:</p> <ul style="list-style-type: none"> • Check the wiring and correct the short circuit. • Acknowledge the error with the EXTf_ACK control bit. 	<ul style="list-style-type: none"> • The current reference point run, relative positioning, and absolute positioning modes are stopped; it is not possible to start a new run in these modes. <ul style="list-style-type: none"> – All 3 digital outputs are set to 0. – Feedback bit POS_ERR = 1 – Feedback bit POS_DONE = 0 • Feedback bit ERR_ENCODER=1 • Feedback bit SYNC = 0 • Generating channel-specific diagnostics • Waits for error acknowledgment EXTf_ACK • Inching MODE is not affected by this error. • The current JOB (reference signal evaluation) is canceled.

Wire Break/Short Circuit of the Encoder Signals	Response of the 1PosU
<p>If an SSI encoder is used:</p> <p>Prerequisite:</p> <ul style="list-style-type: none"> To detect errors of the encoder signals, you must enable the "Encoder signal diagnostics" parameter. <p>Causes:</p> <ul style="list-style-type: none"> Wire break or short circuit of the encoder signals at terminals 9 and 13 or 12 and 16. The parameters for the SSI encoder do not correspond to the encoder connected. <p>What to Do:</p> <ul style="list-style-type: none"> Check the wiring and correct the short circuit. Compare the parameter assignment with the technical specifications of the encoder. Acknowledge the error with the EXTF_ACK control bit. <p>If an incremental encoder is used:</p> <p>Prerequisite:</p> <ul style="list-style-type: none"> The encoder signal diagnostics parameter must be enabled in order to allow error recognition for the signals A, /A and B, /B at 5 V differential signals or for the signals A and B at 24 V signals. The zero marker diagnostics parameter must be enabled in order to allow error recognition for the signals N, /N at 5 V differential signals. If you use an encoder without a zero mark, switch off error detection. If dosing operation is activated, zero marker signal diagnostics is not possible. <p>Causes:</p> <ul style="list-style-type: none"> For 5V differential signals only: Wire break or short circuit of the encoder signals at terminals 9 and 13 or 11 and 15 or 12 and 16. Edge error of the encoder signals recognized so that 1PosU cannot carry out clear direction recognition. <p>What to Do:</p> <ul style="list-style-type: none"> Check the wiring and correct the short circuit. Acknowledge the error with the EXTF_ACK control bit. 	<ul style="list-style-type: none"> The current MODEs relative positioning and absolute positioning are stopped; it is not possible to start a new run in these MODEs. <ul style="list-style-type: none"> All 3 digital outputs are set to 0. Feedback bit POS_ERR = 1 Feedback bit POS_DONE = 0 Feedback bit ERR_ENCODER=1 Feedback bit SYNC = 0 Generating channel-specific diagnostics Waits for error acknowledgment EXTF_ACK Inching MODE is not affected by this error. The current JOB (reference signal evaluation) is canceled.

Errors in the Control of MODEs and JOBs

POS_ERR	Response of the 1PosU
Causes: <ul style="list-style-type: none"> Certain requirements or conditions have not been met at the start of a MODE 	<ul style="list-style-type: none"> The MODE started is not executed. The current run is stopped. <ul style="list-style-type: none"> All 3 digital outputs are set to 0. Feedback bit POS_ERR = 1 Feedback bit POS_DONE = 0
JOB_ERR	Response of the 1PosU
Causes: <ul style="list-style-type: none"> Certain requirements or conditions have not been met at the activation of a JOB 	<ul style="list-style-type: none"> The activated JOB is not executed. <ul style="list-style-type: none"> Feedback bit JOB_ERR = 1

Generating Channel-Specific Diagnostics

In the event of a parameter assignment error, the absence of 2L+ load voltage, a short circuit of the encoder supply or a wire break/short circuit of the encoder signals, the 1PosU generates a channel-specific diagnostics on the connected CPU/master. To do this, you need to enable the group diagnostics parameter (see the device manual of the interface module used).

Error Acknowledgment EXTF_ACK

You must acknowledge the corrected errors (load voltage missing, short circuit of the encoder supply and wire break/short circuit of the encoder signals).

What You Do	Response of the 1PosU
	Feedback bit ERR_2L+ = 1 and/or feedback bit ERR_ENCODER = 1
Your control program detects the set feedback bit ERR_2L+ or ERR_ENCODER. Execute your application-specific error response. Eliminate the cause of the error.	
Switch the EXTF_ACK control bit from 0 to 1	The 1PosU sets the feedback bits ERR_2L+ = 0 and ERR_ENCODER = 0. This tells you that the cause has been eliminated and acknowledged. If ERR_2L+ is still 1 and/or ERR_ENCODER = 1, the cause of the error is not yet eliminated.
Switch the EXTF_ACK control bit from 1 to 0	
In the case of constant error acknowledgment (EXTF_ACK = 1) or at CPU/Master Stop, the 1PosU reports the errors as soon as they are detected and deletes them as soon as they have been eliminated.	

Parameters

Parameters	Meaning	Value range	Default setting
Enables			
Group diagnostics	When group diagnostics is enabled, an encoder error (ERR_ENCODER), no load voltage (ERR_2L+) or a parameter assignment error will result in a channel-specific diagnostics.	<ul style="list-style-type: none"> • Disable • Enable 	Disable
Encoder signal diagnostics	Encoder signals A, /A and B, /B or D, /D are monitored for short circuit and wire break at 5 V differential signals. At incremental position encoders and non-activated dosing operation monitoring of the signal sequence is also carried out. A simultaneous edge change at Signals A and B causes an error. At an SSI encoder monitoring of the frame is carried out additionally (start bit and stop bit)	<ul style="list-style-type: none"> • On • Off 	On
Zero marker diagnostics	At incremental encoders with 5 V differential signals the zero marker signals N, /N are monitored for short circuit and wire break.	<ul style="list-style-type: none"> • On • Off 	On

Feedback Messages

Address	Assignment
Byte 0	Bit 7: ERR_ENCODER Bit 3: SYNC Bit 2: POS_DONE Bit 1: POS_ERR Bit 0: POS_ACK
Byte 4	Bit 7: ERR_2L+ Bit 1: JOB_ERR Bit 0: JOB_ACK

Causes of Errors for POS_ERR

Table 3- 3 Causes of Errors for POS_ERR

Error number	Cause	Remedy
1	JOB unknown or invalid	Permissible MODEs are: <ul style="list-style-type: none"> • MODE 0 • MODE 1 • MODE 3 (not possible at SSI encoders or in dosing operation) • MODE 4 • MODE 5 (not possible in dosing operation)
2	ERR_2L+ is displayed	Check the load voltage (2L+) at terminal 7
3	ERR_ENCODER is displayed	Check the encoder wiring
4	The axis is not synchronized (SYNC=0)	SSI encoder: <ul style="list-style-type: none"> • Eliminate the encoder error. <p>The axis can be synchronized at incremental encoders and non-activated dosing operation with:</p> <ul style="list-style-type: none"> • Search for Reference • Reference Signal Evaluation • Setting of Actual Value
5	The limit switch that lies in the direction in which the drive is moved is active	Check your switches and the wiring as well as the D10 limit switch minus and D11 limit switch plus parameters
7	Inching: DIR_P and DIR_M = 1 Absolute positioning: Start with DIR_P and DIR_M = 0 or relevant control bit DIR_P or DIR_M = 0 Relative positioning: Start with DIR_P and DIR_M = 0 or DIR_P and DIR_M = 1	
8	Absolute positioning : Destination \geq end of rotary axis at incremental encoders or destination \geq encoder range at SSI encoders	
9	Absolute positioning was terminated because JOB 9 was initiated	
10	Search for reference: Reference point coordinates \geq end of rotary axis	
11	Reference point approach: No reference signal found up to the limit switch or between the limit switches	Check your switches, the encoder and the wiring
13	Direction of rotation of the drive and the encoder varies	Check the wiring of the drive and the encoder as well as the reversal of the direction of rotation parameter
15	Inching, relative positioning: In dosing operation DIR_M = 1	

Causes of Errors for JOB_ERR

Table 3- 4 Causes of Errors for JOB_ERR

Error number	Meaning	Remedy
21	JOB unknown or impermissible	Permissible JOBS are: <ul style="list-style-type: none"> • JOB 0 • JOB 1 • JOB 2 (only possible at SSI encoders) • JOB 3 • JOB 4 • JOB 9 (not possible at SSI encoders or in dosing operation) • JOB 10 • JOB 11 (not possible in dosing operation) • JOB 15
23	ERR_ENCODER is displayed	Check the encoder wiring
26	JOB 2 (move encoder range) cannot be initiated because there is an active run	
29	Evaluating the Reference Signal: Reference point coordinate \geq end of rotary axis	
34	Setting an Actual Value: Actual value coordinates \geq encoder range	
35	Display current values: Selection unknown	
36	Latch Function: Edge selection unknown	
37	Display current values: JOB 15 cannot be activated with the latch function running.	
38	Monitoring of the direction of rotation Path difference > 65 535	

3.7 CPU/Master Stop and RESET State

Response to CPU/master STOP

Response to CPU/master STOP	Response of the 1PosU
<ul style="list-style-type: none"> • Due to power-off of the CPU/DP master or • Due to power-off of the IM 151/ IM 151 FO or • Due to failure of DP transmission or • Due to change from RUN to STOP 	<ul style="list-style-type: none"> • The current run is stopped. • All 3 digital outputs are set to 0. • Feedback bit POS_ERR = 0 • Feedback bit POS_DONE = 1

Exiting the CPU-Master-STOP Status

Exiting the CPU/master STOP status	Response of the 1PosU
<ul style="list-style-type: none"> • At power-on of the CPU/DP master or • At power-on of the IM 151/ IM 151 FO or • After failure of the DP transmission or • After a change from STOP to RUN 	<ul style="list-style-type: none"> • The feedback interface of the 1PosU remains current. • The axis remains synchronized, and the actual value is current. • The moved encoder range remains valid. • The changed switch-off and switchover differences and the path difference for the monitoring of the direction of rotation remain valid. • An initiated JOB 9: Evaluating the Reference Signal and JOB 10: Latch function remains active. • The feedback bit selected with JOB 15 is current.

RESET State of the 1PosU

RESET State of the 1PosU and Changing the Parameters of the 1PosU	Response of the 1PosU
<ul style="list-style-type: none"> • Changing the parameters of the 1PosU and downloading the parameter assignment and configuration of the ET 200S station to the CPU/DP master or • Power-on at the power module of the 1PosU or • Inserting the 1PosU in an energized state 	<ul style="list-style-type: none"> • The axis is synchronized, and the actual value corresponds to the current encoder value. • The encoder range has not been moved. • The switch-off and switchover difference is accepted from the parameters. • The path difference for the monitoring of the direction of rotation is set at double the switch-off difference. • JOB 9: Evaluating the Reference Signal and JOB 10: Latch function are not active. • The residual distance is displayed as a feedback value.

3.8 Parameter List

Overview

Parameter List at Incremental Encoders with 5 V Differential Signals

Parameter	Meaning	Value range	Default setting
Enables			
Group diagnostics	When group diagnostics is enabled, an encoder error (ERR_ENCODER), no load voltage (ERR_2L+) or a parameter assignment error will result in a channel-specific diagnostics.	<ul style="list-style-type: none"> • Disable • Enable 	Disable
Encoder signal diagnostics	Encoder signals A, /A and B, /B are monitored for short circuit and wire break. In addition the signal sequence is monitored. A simultaneous edge change at Signals A and B causes an error.	<ul style="list-style-type: none"> • On • Off 	On
Zero marker diagnostics	Zero marker signals N, /N are monitored for short circuit and wire break.	<ul style="list-style-type: none"> • On • Off 	On
Axis			
Dosing operation	Only the encoder signals A and /A are evaluated. This means that only a path change in the positive direction is possible.	<ul style="list-style-type: none"> • Off • On 	Off
Reversal of the direction of rotation	Adjustment of the direction of rotation of the encoder A reversal of the direction of rotation is only possible if no dosing operation is set.	<ul style="list-style-type: none"> • Off • On 	Off
Axis type	Selection of linear axis without limits or rotary axis with overrun/underrun with encoder range	<ul style="list-style-type: none"> • Linear • Rotary 	Linear
End of rotary axis	Only relevant for rotary axis type: Underrun: 0 to end of rotary axis - 1 End of rotary axis - 1 to 0	1 - 16 777 215	36 000
Digital Inputs			
DI0 limit switch minus	Switch on the DI0 digital input is a NC or NO contact	<ul style="list-style-type: none"> • NC contact • NO contact 	NC contact
DI1 limit switch plus	Switch on the DI1 digital input is a NC or NO contact	<ul style="list-style-type: none"> • NC contact • NO contact 	NC contact
DI2 reducing cam	Switch on the DI2 digital input is a NC or NO contact	<ul style="list-style-type: none"> • NC contact • NO contact 	NO contact

Parameter	Meaning	Value range	Default setting
Reference point run and evaluation of the reference signal			
Reference signal	This parameter defines the relevant switch or the combination of switch and zero mark.	<ul style="list-style-type: none"> Reference switch and zero mark Reference switch Zero mark 	Reference switch and zero mark
Reference switch	Relevant in the case of reference signal: <ul style="list-style-type: none"> Reference switch and zero mark Reference switch This parameter defines the referencing direction in which the switch must be traversed.	<ul style="list-style-type: none"> Reduction cam towards minus Reduction cam towards plus Minus limit switch Plus limit switch 	Reduction cam towards minus
Start direction of the reference point run		<ul style="list-style-type: none"> Plus Minus 	Plus
Drive			
Control mode	Type 0 means: <ul style="list-style-type: none"> DO0 travel minus DO1 travel plus DO2 rapid/creep speed Type 1 means: <ul style="list-style-type: none"> DO0 rapid speed DO1 creep speed (rapid speed is 0) DO2 travel plus (1)/minus (0) 	<ul style="list-style-type: none"> 0 1 	0
Switch-off difference	Defines the distance from the destination at which the drive is slowed down from creep speed to 0. If the switch-off difference \geq the switchover difference, there is no switchover point. There is no deceleration from rapid to creep speed, instead the response is executed directly at the switch-off point. You can change the switch-off difference with JOB 3.	0 - 65 535	100
Switchover difference	Defines the distance from the destination at which the drive is slowed down from rapid speed to creep speed. You can change the switchover difference with JOB 4.	0 - 65 535	1000
T _{min} direction change	The digital outputs are switched off, and a change of direction by T _{min} is executed with a delay. T _{min} is effective at each change of direction during a run. T _{min} is not effective at startup after POS_DONE = 1 or POS_ERR = 1. Your input value is multiplied by 10. You thus specify T _{min} in increments of 10 ms (for example, 0 ms, 10 ms or 2550 ms)	0 - 255	0

Parameter List at Incremental Encoders with 24 V Signals

Parameter	Meaning	Value range	Default
Enables			
Group diagnostics	When group diagnostics is enabled, an encoder error (ERR_ENCODER), no load voltage (ERR_2L+) or a parameter assignment error will result in a channel-specific diagnostics.	<ul style="list-style-type: none"> • Disable • Enable 	Disable
Encoder signal diagnostics	A simultaneous edge change at Signals A and B causes an error.	<ul style="list-style-type: none"> • On • Off 	On
Axis			
Dosing operation	Only the encoder signal A is evaluated. This means that only a path change in the positive direction is possible.	<ul style="list-style-type: none"> • Off • On 	Off
Sensor	Selection of the output circuit of the encoder for the signals A, B and N	<ul style="list-style-type: none"> • Current-sourcing switch, push-pull • Mono-switch 	Current-sourcing switch, push-pull
Direction reversal	Adjustment of the direction of rotation of the encoder A reversal of the direction of rotation is only possible if no dosing operation is set.	<ul style="list-style-type: none"> • Off • On 	Off
Axis type	Selection of linear axis without limits or rotary axis with overrun/underrun with encoder range	<ul style="list-style-type: none"> • Linear • Rotary 	Linear
End of rotary axis	Only relevant for rotary axis type: Underrun: 0 to end of rotary axis - 1 Overflow: End of rotary axis - 1 to 0 Parameter assignment error at 0	1 - 16 777 215	36 000
Digital inputs			
DI0 limit switch minus	Switch on the DI0 digital input is an NC or NO contact	<ul style="list-style-type: none"> • NC contact • NO contact 	NC contact
DI1 limit switch plus	Switch on the DI1 digital input is an NC or NO contact	<ul style="list-style-type: none"> • NC contact • NO contact 	NC contact
DI2 reducing cam	Switch on the DI2 digital input is an NC or NO contact	<ul style="list-style-type: none"> • NC contact • NO contact 	NO contact

Parameter	Meaning	Value range	Default
Reference point run and evaluation of the reference signal			
Reference signal	This parameter defines the relevant switch or the combination of switch and zero mark.	<ul style="list-style-type: none"> Reference switch and zero mark Reference switch Zero mark 	Reference switch and zero mark
Reference switch	Relevant in the case of reference signal: <ul style="list-style-type: none"> Reference switch and zero mark Reference switch This parameter defines the referencing direction in which the switch must be traversed.	<ul style="list-style-type: none"> Reduction cam towards minus Reduction cam towards plus Minus limit switch Plus limit switch 	Reduction cam towards minus
Start direction of the reference point run		<ul style="list-style-type: none"> Plus Minus 	Plus
Drive			
Control mode	Type 0 means: <ul style="list-style-type: none"> DO0 travel minus DO1 travel plus DO2 rapid/creep speed Type 1 means: <ul style="list-style-type: none"> DO0 rapid speed DO1 creep speed (rapid speed is then 0) DO2 travel plus (1)/minus (0) 	<ul style="list-style-type: none"> 0 1 	0
Switch-off difference	Defines the distance from the target at which the drive is slowed down from creep speed to 0. If the switch-off difference \geq the switchover difference, there is no switchover point. There is no deceleration from rapid to creep speed, instead the response is executed directly at the switch-off point. You can change the switch-off difference with JOB 3.	0 - 65 535	100

3.8 Parameter List

Parameter	Meaning	Value range	Default
Switchover difference	Defines the distance from the target at which the drive is slowed down from rapid speed to creep speed. You can change the switchover difference with JOB 4.	0 - 65 535	1000
T _{min} direction change	The digital outputs are switched off, and a change of direction by T _{min} is executed with a delay. T _{min} is effective at each change of direction during a run. T _{min} has no effect at startup after POS_DONE = 1 or POS_ERR = 1. Your input value is multiplied by 10. You thus specify T _{min} in increments of 10 ms (for example, 0 ms, 10 ms or 2550 ms)	0 - 255	0

Parameter List at SSI Encoder:

Parameter	Meaning	Value range	Default
Enables			
Group diagnostics	When group diagnostics is enabled, an encoder error (ERR_ENCODER), no load voltage (ERR_2L+) or a parameter assignment error will result in a channel-specific diagnostics.	<ul style="list-style-type: none"> • Disable • Enable 	Disable
Encoder signal diagnostics	Encoder signals D, /D are checked for short circuit and wire break. Monitoring of the frame is carried out additionally (start bit and stop bit)	<ul style="list-style-type: none"> • On • Off 	On
Encoder and Axis			
Encoder	Selection of single-turn encoder (SSI 13 bit) or multiturn encoder (SSI 25 bit)	<ul style="list-style-type: none"> • SSI-13Bit • SSI-25Bit 	SSI-13Bit
Transmission rate		<ul style="list-style-type: none"> • 125 kHz • 250 kHz • 500 kHz • 1 MHz 	125 kHz
Number of increments		4, 8, 16, 32, 64, 128, 256, 512, 1024, 2048, 4096, 8192	4096
Number of rotations	Only relevant in the case of multiturn encoders. In the case of single-turn encoders, the 1PosU sets the number of rotations to 1.	4, 8, 16, 32, 64, 128, 256, 512, 1024, 2048, 4096,	4096
Direction reversal	Adjustment of the direction of rotation of the encoder	<ul style="list-style-type: none"> • Off • On 	Off
Axis type	Selection of linear axis without limits or rotary axis with overrun/underrun with encoder range	<ul style="list-style-type: none"> • Linear • Rotary 	Linear
Digital inputs			
DI0 limit switch minus	Switch on the DI0 digital input is an NC or NO contact	<ul style="list-style-type: none"> • NC contact • NO contact 	NC contact
DI1 limit switch plus	Switch on the DI1 digital input is an NC or NO contact	<ul style="list-style-type: none"> • NC contact • NO contact 	NC contact
DI2 latch signal	Switch on the DI2 digital input is an NC or NO contact	<ul style="list-style-type: none"> • NC contact • NO contact 	NO contact

3.8 Parameter List

Parameter	Meaning	Value range	Default
Drive			
Control mode	<p>Type 0 means:</p> <ul style="list-style-type: none"> • DO0 travel minus • DO1 travel plus • DO2 rapid/creep speed <p>Type 1 means:</p> <ul style="list-style-type: none"> • DO0 rapid speed • DO1 creep speed (rapid speed is 0) • DO2 travel plus (1)/minus (0) 	<ul style="list-style-type: none"> • 0 • 1 	0
Switch-off difference	<p>Defines the distance from the target at which the drive is slowed down from creep speed to 0.</p> <p>If the switch-off difference \geq the switchover difference, there is no switchover point. There is no deceleration from rapid to creep speed, instead the response is executed directly at the switch-off point.</p> <p>You can change the switch-off difference with JOB 3.</p>	0 - 65 535	100
Switchover difference	<p>Defines the distance from the target at which the drive is slowed down from rapid speed to creep speed.</p> <p>You can change the switchover difference with JOB 4.</p>	0 - 65 535	1000
T _{min} direction change	<p>The digital outputs are switched off, and a change of direction by T_{min} is executed with a delay.</p> <p>T_{min} is effective at each change of direction during a run.</p> <p>T_{min} has no effect at startup after POS_DONE = 1 or POS_ERR = 1.</p> <p>Your input value is multiplied by 10. You thus specify T_{min} in increments of 10 ms (for example, 0 ms, 10 ms or 2550 ms)</p>	0 - 255	0

3.9 Diagnostics

3.9.1 Diagnostics using the LED display

LED display on the 1PosUniversal

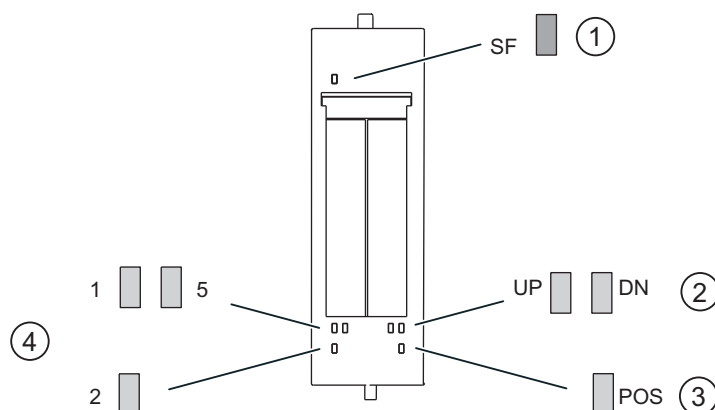

- ① Group error (red)
- ② Status display for a change in an actual value (green)
- ③ Positioning underway (green)
- ④ Status displays for digital inputs (green)

Status and error displays by means of LEDs on the 1PosUniversal

The table below shows the status and error displays on the 1PosUniversal.

Event (LEDs)							Cause	Remedy
SF	1	5	2	UP	DN	POS		
On							No parameter assignment. There is a diagnostic message.	Check the parameter assignment. Evaluate the diagnostics data.
	On						DI 0 is activated.	
		On					DI 1 is activated.	
			On				DI 2 is activated.	
				On			In the case of actual value change from lower to higher values	
					On		In the case of actual value change from higher to lower values	
						On	Positioning is running and one of the 3 digital outputs is set.	

3.9.2 Error Types of Channel-Specific Diagnostics

For information on the structure of the channel-related diagnostics, refer to the manual on the interface module used in your ET 200S station.

1PosUniversal error types

The following table shows the error types on the 1PosUniversal.

Error class		Meaning	Remedy
1D	00001: Short circuit	Short circuit of the sensor supply.	Check the wiring to the sensor. Correct the process wiring.
16D	10000: Parameter assignment error	Parameters have not been assigned to the module.	Correct the parameter assignment.
17D	10001: Load voltage 2L + missing	Power supply voltage not present or too low.	Correct the process wiring. Check the supply voltage.
26D	11010: External error	Wire break/short circuit of the sensor signals. Wire break in the sensor cable, or sensor cable is not connected. Sensor is defective or there are faults. Sensor type, transmission rate, and monoflop time do not correspond to the sensor connected; programmable sensors do not correspond to the settings on the module.	Correct the process wiring. Correct the parameter assignment. Replace the sensor.

3.10 Control and Feedback Signals

Assignment of the Control Interface

Address	Assignment					
Byte 0	Bits 0.7 to 0.4 stand for the MODEs					
	Bit	7	6	5	4	
		0	0	0	0	MODE 0 = Stop
		0	0	0	1	MODE 1 = Inching
		0	0	1	1	MODE 3 = Reference Point Run
		0	1	0	0	MODE 4 = Relative Positioning
		0	1	0	1	MODE 5 = Absolute Positioning
	Bit 3: SPEED (SPEED = 0 is creep feed; SPEED = 1 is rapid feed)					
	Bit 2: DIR_M					
	Bit 1: DIR_P					
	Bit 0: START					
Bytes 1 to 3	With MODE 3 = reference point run: reference point coordinates					
	at MODE 4 = Relative positioning: distance					
	at MODE 5 = Absolute positioning: target					
Byte 4	Bits 4.7 to 4.4 stand for the JOBs					
	Bit	7	6	5	4	
		0	0	0	0	JOB 0 = Cancel JOB processing
		0	0	0	1	JOB 1 = Set the actual value
		0	0	1	0	JOB 2 = Move encoder range (only at SSI encoders)
		0	0	1	1	JOB 3 = Change the switch-off difference
		0	1	0	0	JOB 4 = Change the switchover difference
		1	0	0	1	JOB 9 = Evaluate the reference signal
		1	0	1	0	JOB 10 = Latch function
		1	0	1	1	JOB 11 = Set the monitoring of the direction of rotation
	1	1	1	1	JOB 15 = Display current values	
	Bit 3: EXTF_ACK					
	Bit 2: Reserve = 0					
	Bit 1: Reserve = 0					
	Bit 0: JOB_REQ					

3.10 Control and Feedback Signals

Address	Assignment
Bytes 5 to 7	Corresponding to the selected JOB: <ul style="list-style-type: none"> • With JOB 1= actual value coordinates • With JOB 3 = switch-off difference • With JOB 4 = switchover difference • With JOB 9 = reference point coordinates • With JOB 10 <ul style="list-style-type: none"> – Byte 5: Bit 0 = latch at positive edge at DI2 – Byte 5: Bit 1 = latch at negative edge at DI2 • With JOB 11 = path difference for direction of rotation monitoring • With JOB 15 <ul style="list-style-type: none"> – Byte 5: 0 = Residual distance – Byte 5: 1 = Actual speed – Byte 5: 2 = error information

Assignment of the Feedback Interface

Address	Assignment
Byte 0	Bit 7: ERR_ENCODER Bit 6: STATUS DO 2 Bit 5: STATUS DO 1 Bit 4: STATUS DO 0 Bit 3: SYNC Bit 2: POS_DONE Bit 1: POS_ERR Bit 0: POS_ACK
Bytes 1 to 3	Actual value
Byte 4	Bit 7: ERR_2L+ Bit 6: STATUS DI 2 reduction cams Bit 5: STATUS DI 1 limit switch plus Bit 4: STATUS DI 0 limit switch minus Bit 3: Reserve Bit 2: LATCH_DONE Bit 1: JOB_ERR Bit 0: JOB_ACK
Bytes 5 to 7	Feedback value

Access to Control and Feedback Interface in STEP 7 Programming

	Configured with STEP 7 via GSD file ¹⁾ (hardware catalog\PROFIBUS DP\ other field devices\ET 200S)	Configured with STEP 7 via HW Config (hardware catalog\PROFIBUS DP\ET 200S)
Feedback interface	Read with SFC 14 "DPRD_DAT"	Load command e.g. L PED
Control interface	Write with SFC 15 "DPWR_DAT"	Transfer command e.g. T PAD
¹⁾ Load and transfer commands are also possible with CPU 3xxC, CPU 318-2 (as of V3.0), CPU 4xx (as of V3.0)		

3.11 Technical Specifications

Overview

Technical specifications 1PosU	
Dimensions and weight	
Dimension W x H x D (mm)	30 x 81 x 52
Weight	Approx. 65 g
Data for specific modules	
Number of channels	1
Voltages, currents, potentials	
Rated load voltage L+ • Reverse polarity protection	24 VDC Yes
Isolation • Between the backplane bus and the I/O	Yes
Encoder supply • Output voltage • Output current	L+ -0.8 V Maximum 500 mA (total current at terminals 6 and 10), short circuit proof
Current consumption • From the backplane bus • From the load voltage L+ (no load)	Max. 10 mA Max. 50 mA
Power dissipation	Typ. 2 W
Data for the digital inputs	
Input voltage • Rated value • 0 signal • 1 signal	24 VDC -30 V to 5 V 11 V to 30 V
Input current • 0 signal • 1 signal	≤ 2 signal (permissible leakage current) 9 mA (typically)
Minimum pulse width	500 μs
Connection of a two-wire BERO Type 2	Possible
Input characteristic curve	To IEC 1131, Part 2, Type 2
Length of cable	50 m

Technical specifications 1PosU	
Data for the Digital Outputs	
Output voltage • Rated value • 0 signal • 1 signal	24 VDC $\leq 3V$ $\geq L+ (-1V)$
Output current • 0 signal (leakage current) • 1 signal – Rated value – Permitted range	$\leq 0.3 \text{ mA}$ 0.5 A 7 mA to 0.6 A
Switch rate • Resistive load • Inductive load • Lamp load	100 Hz 2 Hz $\leq 10 \text{ Hz}$
Lamp load	$\leq 5 \text{ W}$
Output delay (resistive load, output current 0.5 A) • At 0 to 1 • At 1 to 0	Typ. 150 μs Typ. 150 μs
Short circuit protection of the output	Yes
Threshold on	0.7 A to 1.8 A
Inductive extinction	Yes; L+ -(55 to 60 V)
Digital input control	Yes
Cable lengths • Unshielded • Shielded	600 m 1000 m
Encoder Connection at Incremental Encoders with 5 V Differential Signals	
Level	To RS 422
Terminating resistance	330 Ω
Differential input voltage	Min. 1 V
Max. frequency	500 kHz
Galvanic isolation from ET200S bus	Yes
Length of cable: • Shielded	Max. 50 m

3.11 Technical Specifications

Technical specifications 1PosU		
Encoder Connection at Incremental Encoders with 24 V Signals		
Galvanic isolation from ET200S bus	Yes	
Max. frequency	100 kHz	
Length of cable shielded	Max. 50 m	
Input voltage	<ul style="list-style-type: none"> • Rated value • 0 signal • 1 signal 	
	24 V DC -30 V to 5 V 11 V to 30 V	
Input current	<ul style="list-style-type: none"> • 0 signal • 1 signal 	
	≤ 2mA (standby current) 9mA (typically)	
Connection of a two-wire BERO Type 2	Yes	
Input characteristic curve	To IEC 1131, Part 2, Type 2	
Encoder connection SSI		
Position detection	Absolute	
Differential signals for SSI data and SSI clock	According to RS422	
Data transmission rate and line length with absolute encoders (twisted pair and shielded)	<ul style="list-style-type: none"> • 125 kHz max. 320 m • 250 kHz max. 160 m • 500 kHz max. 60 m • 1 MHz max. 20 m • 2 MHz max. 8 m 	
Age of the encoder value	<ul style="list-style-type: none"> • Max. (2 * frame runtime) + 64 µs • Min. frame runtime 	
Frame runtime	13 Bit	25 Bit
• 125 kHz	112 µs	208 µs
• 250 kHz	56 µs	104 µs
• 500 kHz	28 µs	52 µs
• 1 MHz	14 µs	26 µs
• 2 MHz	7 µs	13 µs
Monoflop time ¹	64 µs	
Status, Diagnostics		
Change in actual value (up)	UP LED (green)	
Change in actual value (down)	DN LED (green)	
Status display positioning in operation	LED POS (green)	
Status display DI0 (minus hardware limit switch)	LED 1 (green)	
Status display DI1 (plus hardware limit switch)	LED 5 (green)	
Status display DI2 (reducing cam)	LED 2 (green)	
Group error on the 1PosU	SF LED (red)	
Diagnostic information	Yes	

Technical specifications 1PosU	
Response Times	
Update rate for feedback messages	2 ms
Response time at the switchover or switch-off point	At incremental encoder: Output delay + 30 μ s For SSI encoder: Output delay + Frame runtime + 30 μ s
Latch response time	For incremental encoder: Typ. 400 μ s For SSI encoder: Typ. 400 μ s + age of encoder value
¹ Encoders with a monoflop time greater than 64 μ s cannot be used with the 1PosU.	

Index

1

- 1PosU
 - Technical specifications, 134
 - Terminal assignment diagram, 70
- 1STEP 5V
 - Technical Specifications, 59
 - Terminal diagram, 16

A

- Absolute incremental mode (function of the 1STEP 5V), 33
- Absolute Positioning (MODE 5), 96
- Acceleration / delay a, 22
- Activating JOBS, 78
- Axis, 79
- Axis type (function of the 1STEP 5V), 38
- Axis types, 61

B

- Base frequency, 23
- Brief instructions on commissioning
 - 1STEP 5V, 11

C

- Canceling JOB 10, 99
- Canceling JOB 9, 99
- Canceling JOB processing, 99
- Causes of Errors for JOB_ERR, 101, 103, 107, 109, 111, 113, 120
- Causes of Errors for POS_ERR, 85, 92, 95, 98, 119
- Changing
 - Parameters during operation, 41
- Changing the Switch-Off Difference (JOB 3), 104
- Changing the Switchover Difference (JOB 4), 105
- Control and feedback interface
 - Accessing with STEP 7 programming, 55, 133
- Control and feedback signals of the 1PosU, 131
- Control interface, 50, 131
- Control mode, 80
- Control program
 - Interface to, 76

- CPU/master STOP
 - Response of the 1PosU, 121
 - Response of the 1STEP 5V, 44

D

- Diagnostics, 61, 114, 136
- Digital input DI0 (3), 42
- Digital input DI1 (7), 43
- Displaying Current Values (JOB 15), 112
- Drive, 79
 - controlling, 80

E

- Effect of the Directional Enables, 82
- Encoder, 79
- Encoder range, 73
- Encoder signals
 - Evaluate, 79
- Error acknowledgment EXTF_ACK, 117
- Error detection, 58, 114
- Evaluating the Reference Signal (JOB 9), 106
- Evaluation of the Encoder Signals, 79
- Example for commissioning
 - 1PosU, 64
- External Errors, 115

F

- Feedback interface, 49, 132
- Frequency, 27
- Functions of the 1PosU, 75
 - Absolute Positioning, 75
 - Behavior at CPU-Master-STOP, 75
 - Change switch-off difference, 75
 - Change Switchover Difference, 75
 - Display Current Values, 75
 - Error Detection/Diagnostics, 75
 - Inching, 75
 - Latch Function, 75
 - Move Encoder Range, 75
 - Reference Signal Evaluation, 75
 - Relative Positioning, 75
 - Search for Reference, 75
 - Setting of Actual Value, 75

- Setting the Monitoring of the Direction of Rotation, 75
- Stop, 75
- Functions of the 1STEP 5V
 - Absolute incremental mode, 33
 - Axis type, 38
 - Hold traversing job, 36
 - Pulse Enable, 40
 - Reference point approach, 26
 - Relative incremental mode, 32
 - Set home position, 31
 - Speed-control mode, 34
- Fundamentals of controlled positioning, 72
- Fundamentals of Positioning, 18

G

- Group error, 136

H

- Hardware limit switch, 81
- Holding the traversing job (function of the 1STEP 5V), 36

I

- Inching (MODE 1), 84

L

- Linear axis, 73

M

- Maximum frequency/velocity of the axis F_{max} , 21
- Minus direction, 74
- Modulo axis, 38
- Moving the Encoder Range (JOB 2), 102

O

- Operating range, 61, 73
- Output frequency/velocity F_a , 21

P

- Parameter
 - 1STEP 5V, 45

- Parameter assignment error, 46, 114
- Parameters
 - 1PosU, 122
 - during operation, 41
- Plus direction, 74
- Position, 96
- Power unit for stepping motors, 18
- Product overview
 - 1PosU, 61
 - 1STEP 5V, 7
- Pulse enable (function of the 1STEP 5V), 40

R

- Reference cam, 36
- Reference point approach
 - Function of the 1STEP 5V, 26
- Reference point approach of the 1STEP 5V
 - Execution, 28
- Reference Point Run (MODE 3), 86
- Relative incremental mode (function of the 1STEP 5V), 32
- Relative Positioning (MODE 4), 93
- RESET state, 121
- Residual distance, 27
- Response to CPU/master STOP
 - 1PosU, 121
 - 1STEP 5V, 44
- Reversal of the direction of rotation, 79
- Rotary axis, 74

S

- Safety concept, 10, 63
- Sequence of execution of the search for reference, 28
- Set home position (function of the 1STEP 5V), 31
- Setting the Actual Value (JOB 1), 100
- Setting the Monitoring of the Direction of Rotation (JOB 11), 110
- Setting up a positioning control, 10, 63
- Speed-control mode (function of the 1STEP 5V), 34
- Start position, 73
- Start position of the reference point run, 89
- Starting
 - Traversing job, 56
- Starting MODEs, 77
- Starting on the hardware limit switch, 82
- Starting the traversing job
 - Execution, 56
- Start-stop frequency F_{ss} , 20
- Status, 136

Status display DI0, 136
Status display DI1, 136
Status display DI2, 136
Stepping motors, 18
Stop (MODE 0), 83
Switch-off difference, 73
Switch-off point, 73
Switchover difference, 73
Switchover point, 73

T

Target, 73
Technical specifications
 1PosU, 134
Technical Specifications
 1STEP 5V, 59
Terminal assignment diagram
 1PosU, 70
Terminal diagram
 1STEP 5V, 16
Traversal curve of the 1STEP 5V, 20

