

44-527



SIMODRIVE 610

Transistor PWM Inverter for Three-Phase Feed Drives with Analog Control

Instruction Manual Edition 08.91

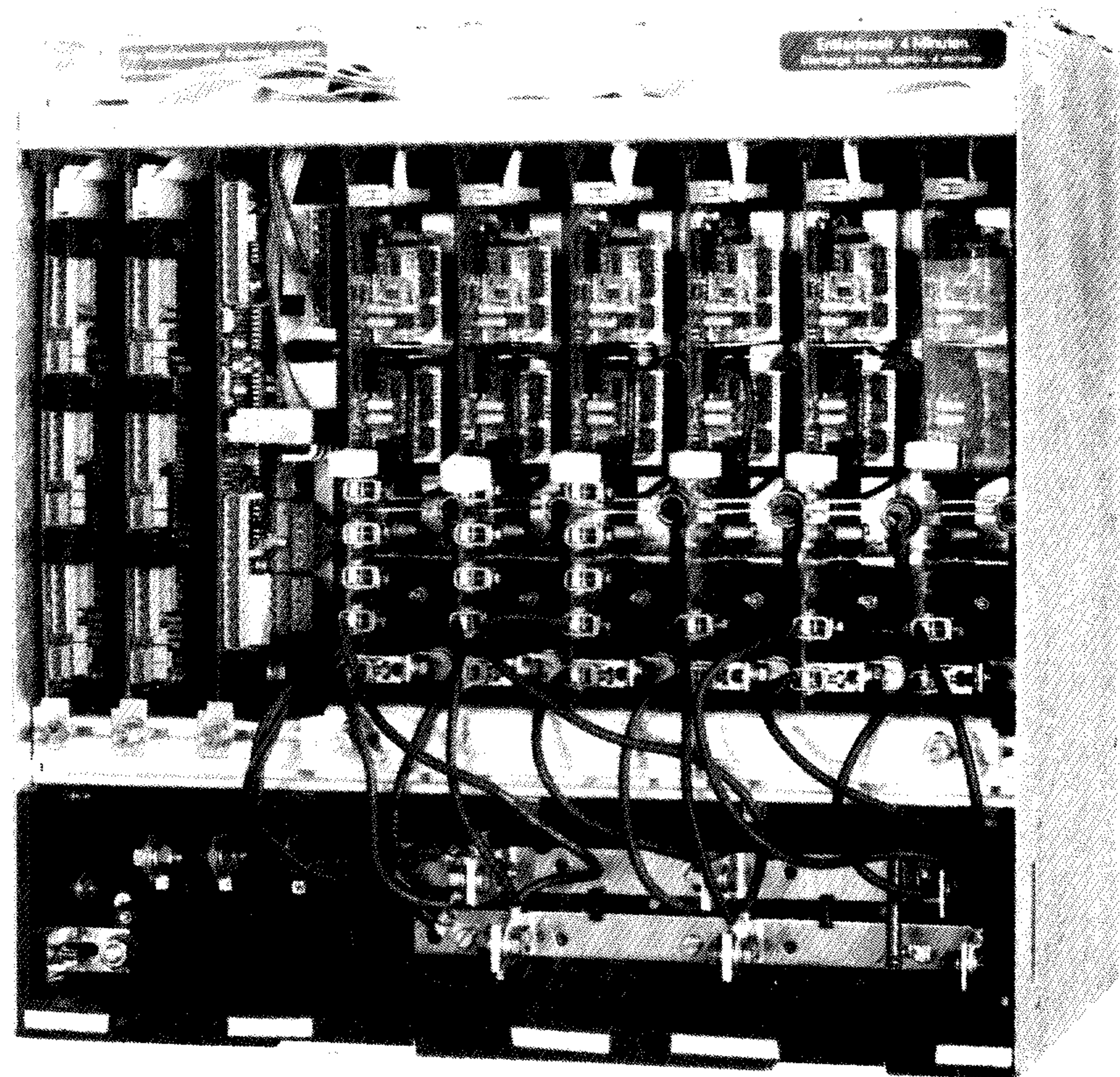

Manufacturer Documentation

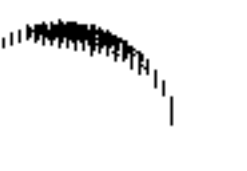

SIMODRIVE 610

Transistor PWM Inverter for Three-Phase Feed Drives with Analog Control

Instruction Manual

Manufacturer-Documentation

Edition 08.91

SIMODRIVE® Documentation

Printing history

Brief details of this edition and previous editions are listed below.

The status of each edition is shown by the code in the "Remarks" column.

Status code in "Remarks" column:

A . . . New documentation.

B . . . Unrevised reprint with new Order-No.

C . . . Revised edition with new status.

If factual changes have been made on the page since the last edition, this is indicated by a new edition coding in the header on that page.

Edition	Order-No.	Remarks
08.91	6SC6101-0AA76 (GWE 462 012.9600.76 Jb-101)	C

Other functions not described in this documentation might be executable in the control. This does not, however, represent an obligation to supply such functions with a new control or when servicing.

This publication was produced on the Siemens 5800 Office System.
Subject to change without prior notice

The reproduction, transmission or use of this document or its contents is not permitted without express written authority. Offenders will be liable for damages. All rights, including rights created by patent grant or registration of a utility model or design, are reserved.

© Siemens AG 1987 All Rights Reserved

Preliminary Remarks

These instructions do not apply to units with controller modules

**6SC6100-0NA00
6SC6100-0NA10
6SC6100-0NA20**

The SIMODRIVE unit may not be connected to a supply system with ELCBs (permitted under DIN VDE 0160, Section 6.5).

In the operational state, protection against direct contact is afforded in a form to render the units suitable for installation in general operating areas (DIN VDE 0558 Part 1, Section 5.4.3.2.4).

In compliance with DIN VDE 0160/05.88, all SIMODRIVE units are subjected to a high-voltage test at the time of routine testing. If the electrical equipment of machine tools undergoes high-voltage testing, all connectors must be separated or terminals opened (permissible under DIN VDE 0113, Part 1, Section 13.2). Damage to sensitive electronic components can thus be prevented.

Pertinent wiring manual:

Order No.: 6SC6101-0BA00

This Instruction Manual is also available in the following other languages:

German
French
Spanish
Italian
Russian

Order No.: 6SC6101-0AA00
6SC6101-0AA77
6SC6101-0AA78
6SC6101-0AA72
6SC6101-0AA56

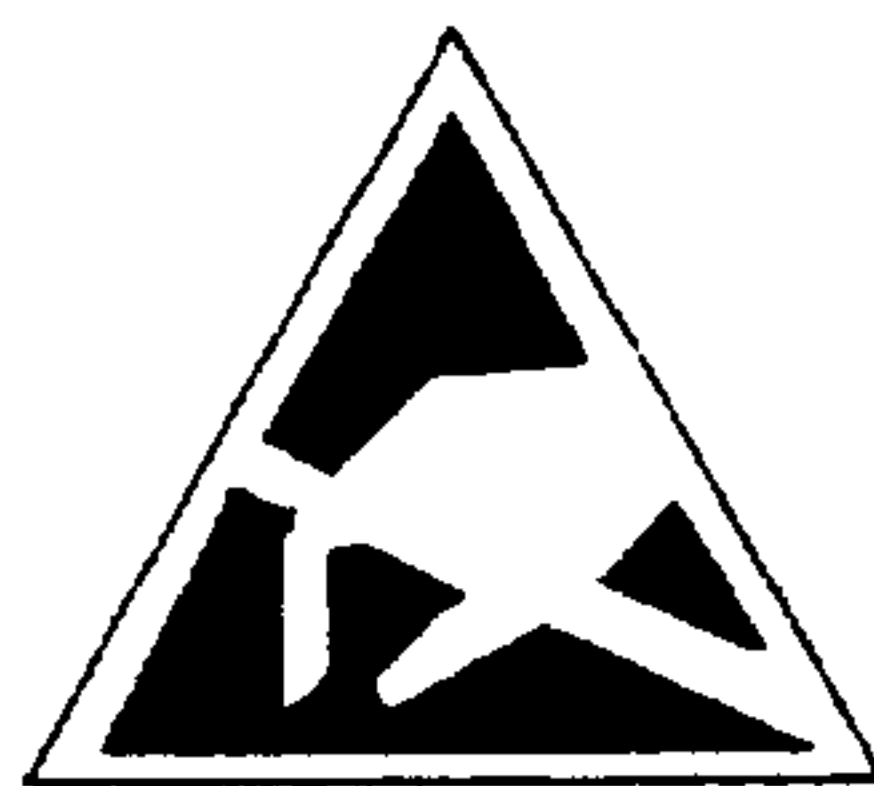

CAUTION

The modules include electrostatically sensitive devices. Before touching a PCB the person carrying out the work must himself be electrostatically discharged. The simplest way of accomplishing this is to touch an electrically conducting earthed object (e.g. a bare metal part of a switchboard or the PE contact of a socket outlet).

These instructions do not purport to cover all details or variations in equipment, nor to provide for every possible contingency to be met in connection with installation, operation or maintenance.

Should further information be desired or should particular problems arise which are not covered sufficiently for the Purchaser's purposes, the matter should be referred to the local Siemens Sales Office.

The contents of this instruction manual shall not become part of or modify any prior or existing agreement, commitment or relationship. The Sales Contract contains the entire obligations of Siemens. The warranty contained in the contract between the parties is the sole warranty of Siemens. Any statements contained herein do not create new warranties of modify the existing warrenty.

Safety instructions

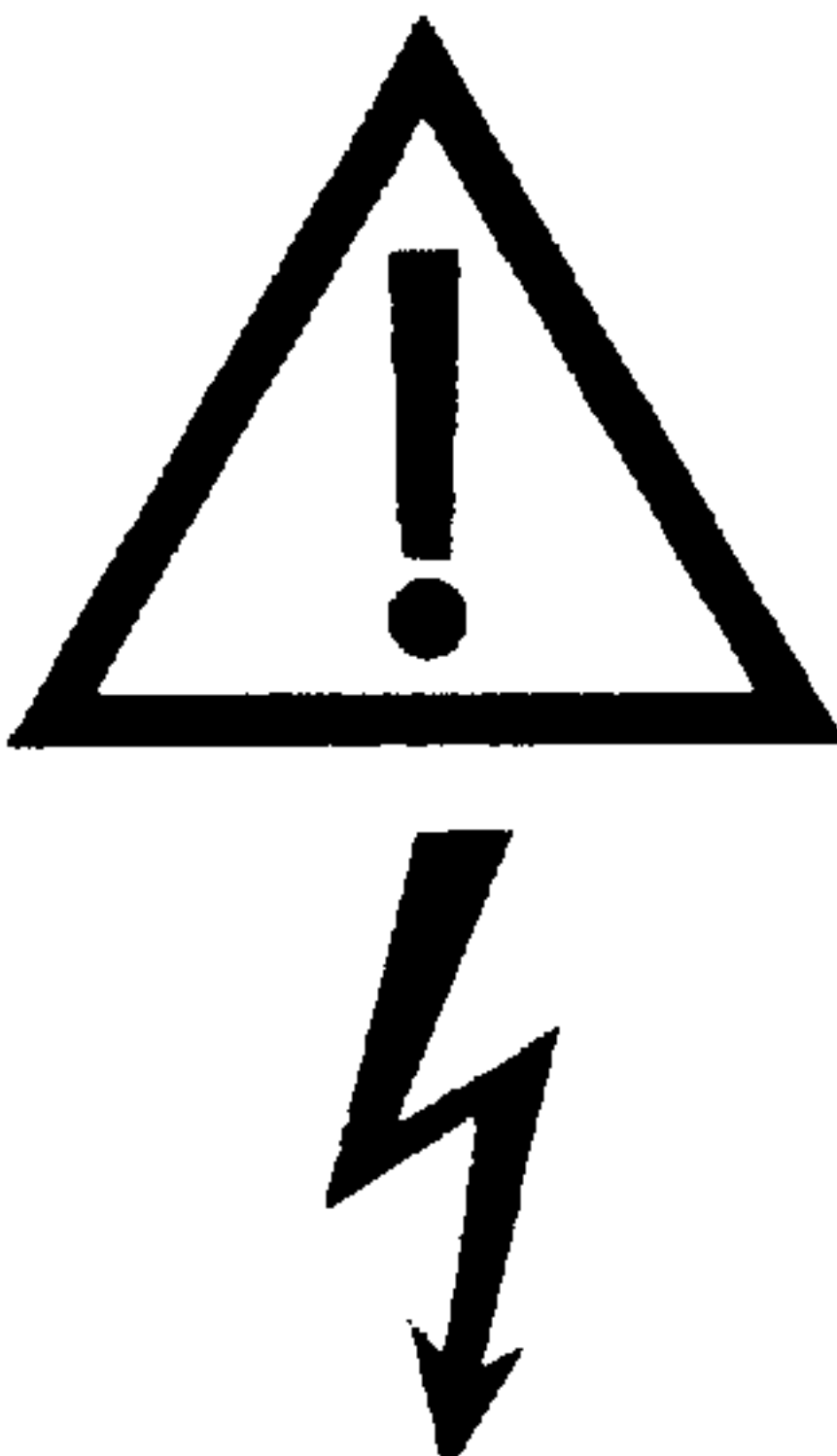
	WARNING
	<p>Hazardous voltages are present in this electrical equipment during operation.</p> <p>Non-observance of the safety instructions can result in severe personal injury or property damage.</p> <p>Only qualified personnel should work on or around this equipment after becoming thoroughly familiar with all warnings, safety notices, and maintenance procedures contained herein.</p> <p>The successful and safe operation of this equipment is dependent on proper handling, installation, operation and maintenance.</p>

Definitions

- **QUALIFIED PERSON**

For the purpose of this instruction manual and product labels, a "qualified person" is one who is familiar with the installation, construction and operation of the equipment and the hazards involved. In addition, he has the following qualifications:

1. Is trained and authorized to energize, de-energize, clear, ground and tag circuits and equipment in accordance with established safety practices.
2. Is trained in the proper care and use of protective equipment in accordance with established safety practices.
3. Is trained in rendering first aid.

- **DANGER**

For the purpose of this instruction manual and product labels, "Danger" indicates death, severe personal injury or substantial property damage **will** result if proper precautions are not taken.

- **WARNING**

For the purpose of this instruction manual and product labels, "Warning" indicates death, severe personal injury or substantial property damage **can** result if proper precautions are not taken.

- **CAUTION**

For the purpose of this instruction manual and product labels, "Caution" indicates minor personal injury or property damage can result if proper precautions are not taken.

- **NOTE**

For the purpose of this instruction manual, "Note" indicates information about the product or the respective part of the instruction manual which is essential to highlight.

Description of the unit

1

Installation

2

Commissioning

3

Maintenance

4

Block diagram

5

Terminal connection diagram

6

Circuit diagram

7

Wiring of different power module variants

8

Dimension drawings

9

Setting elements

10

Contents

	Page
1	Description of the unit 1-1
1.1	Application 1-1
1.2	Mode of operation 1-1
1.3	Technical data 1-2
1.3.1	Ordering data overview 6SC6101-.A-Z 1-2
1.3.1.1	Casing 1-2
1.3.1.2	Power modules 1-2
1.3.1.3	Options 1-3
1.3.2	Ordering data overview 6SC6101-.B-Z 1-3
1.3.2.1	Casing 1-3
1.3.2.2	Power modules 1-4
1.3.2.3	Controls 1-4
1.3.2.4	Link circuit 1-4
1.3.2.5	Options 1-5
1.3.3	Rated data 1-5
2	Installation 2-1
2.1	Installation of units 2-1
2.2	Connecting instructions 2-1
2.3	Inrush current limitation 2-2
2.4	Connecting cable between the motor and the PWM inverter (sensor cable) 2-3
2.5	Screen connection and strain relief of cables 2-4
2.6	Terminals 2-6
3	Commissioning 3-1
3.1	Matching the control system 3-1
3.1.1	Matching the tacho voltage 3-1
3.1.2	Matching tables for motor/pulse-width-modulated inverter 3-3
3.1.3	Current setpoint limitation, "Hold against mechanical stop" function ... 3-20
3.1.4	Speed controller adaptation 3-21
3.1.5	Reversal 3-22
3.1.6	Electrical weight compensation 3-22
3.1.7	Current-controlled operation 3-23
3.1.8	Current setpoint for parallel operation 3-24
3.1.9	External power supply for controller enabling 3-25
3.1.10	External voltage input for storage of fault memory signals 3-25
3.1.11	Changing of variable components in the speed setpoint channel 3-26
3.1.12	Monitoring circuit "Speed controller at stop" 3-26
3.1.13	Operation of control axes without power circuit module 3-27
3.1.14	Testing the load cycle 3-28

3.2	Signals	3-29
3.2.1	Ready/fault signals	3-29
3.2.2	Resetting the fault memories	3-29
3.2.3	I ² t and motor overtemperature signals	3-29
3.3	Test sockets, display elements	3-30
3.4	Start-up	3-31
4	Maintenance	4-1
4.1	Maintenance instructions	4-1
4.2	Faults	4-1
4.3	Spare parts	4-3
4.4	Connectors	4-4
5	Block diagram	5-1
6	Terminal connection diagram	6-1
7	Circuit diagram	7-1
8	Wiring of different power module variants	8-1
9	Dimension drawings	9-1
10	Setting elements	10-1
	Notes on electrostatic charges	10-2
	Addresses	10-3
	Standards and specifications	10-3
	Setting data	10-4

1 Description of the unit

1.1 Application

Type SIMODRIVE 610 transistor pulse-width-modulated inverters are used together with brushless three-phase servo motors of the 1FT5 series for driving the feed axes of machine tools. The inverters control the speed of the drive in four-quadrant operation and satisfy highest demands on the dynamic control response.

1.2 Mode of operation

The control circuit of the three-phase brushless feed drive includes a speed and a current control circuit in cascaded arrangement. The output signal of the current controller is applied to a pulse-width modulator which converts the continuous analog value into a binary signal. The pulse-duty factor of this signal is proportional to the amplitude of the input signal. This pulse-width-modulated setpoint signal controls the power controller which produces a voltage proportional to the setpoint, the mean value of which is determined by the pulse-duty factor.

In three-phase brushless feed drives the function of the electro-mechanical commutator is taken over by an electronic commutating system. This commutator, i.e. the transistor pulse-width-modulated inverter, is controlled by the rotor position transmitter signals.

The actual speed value is derived from a brushless AC tachogenerator.

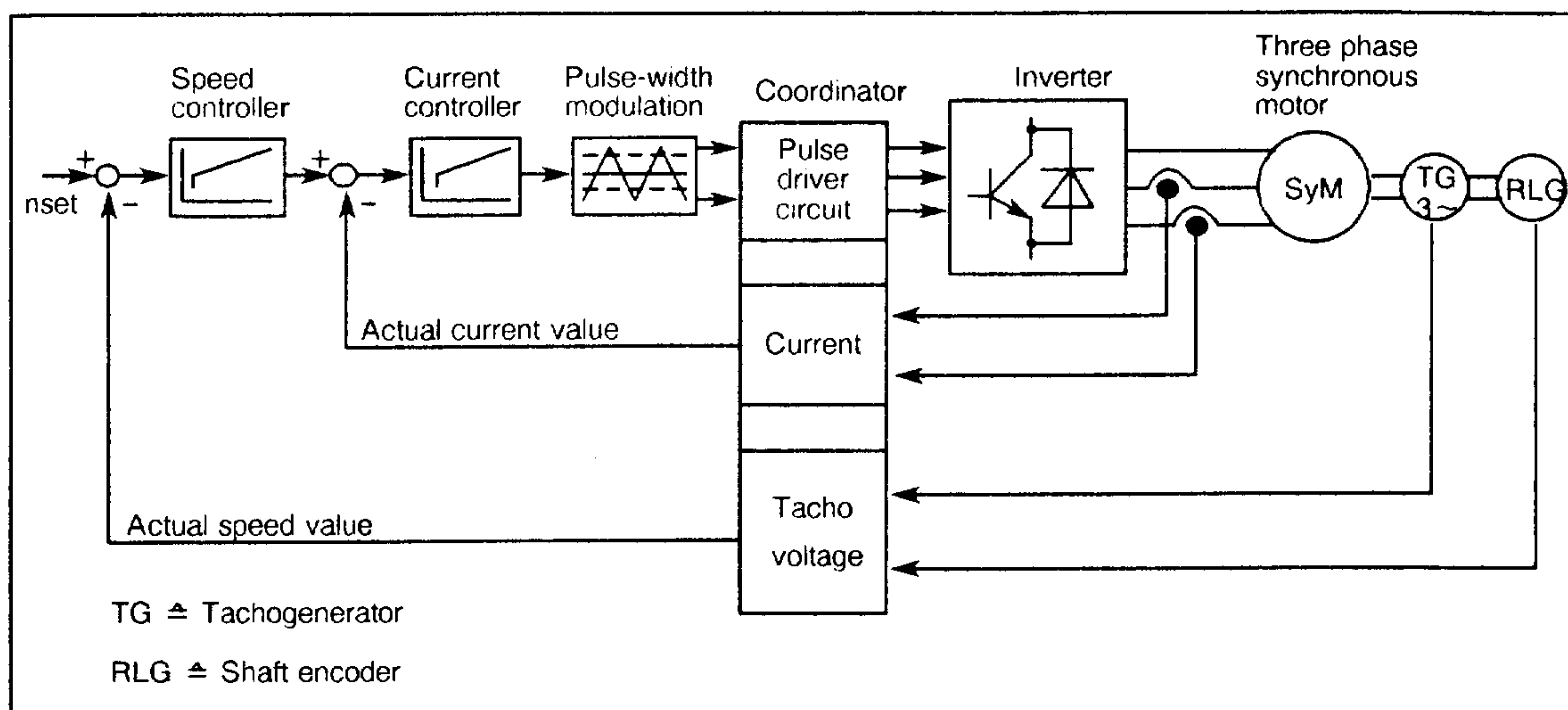

Fig. 1.1 Block diagram of an AC feed drive

1.3 Technical data

1.3.1 Ordering data overview 6SC6101-.A-Z

1.3.1.1 Casing

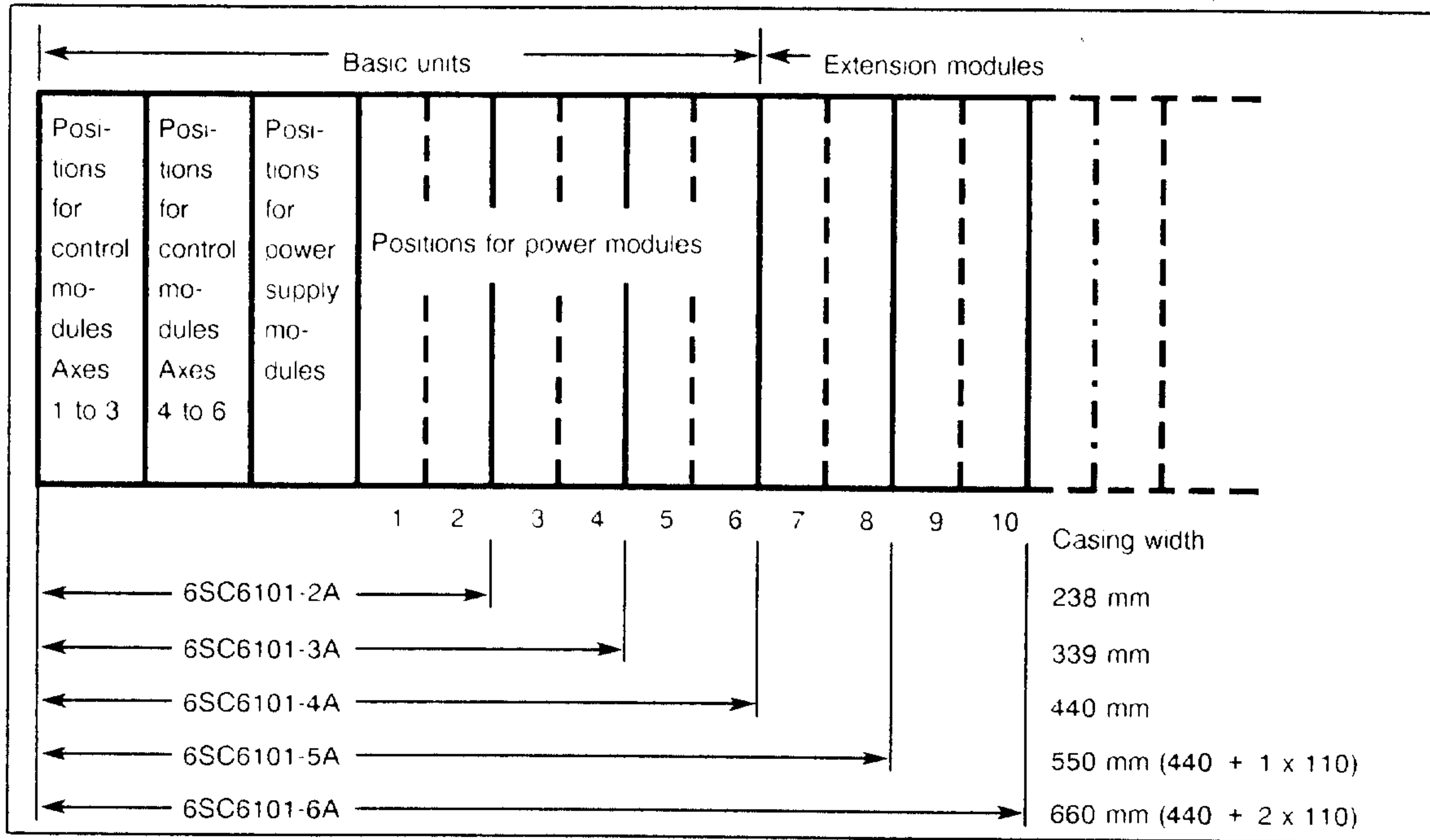

Fig. 1.2 Casing

1.3.1.2 Power modules

Designation*)	Number of axes	Current I_N/I_{max}	Notes	Expansion set
A13, E13, H13, F13 A23, E23, H23, F23 A33, E33, H33, F33	1 2 3	3/6 A	1 axis on one module 2 axes on one module 3 axes on one module	6SC6103-0SE80 6SC6103-0SG80 6SC6103-0SN80
A18, E18, H18, F18 A28, E28, H28, F28 A38, E38, H38, F38	1 2 3	8/16 A	1 axis on one module 2 axes on one module 3 axes on one module	6SC6108-0SE80 6SC6108-0SG80 6SC6108-0SN80
A20, E20, H20, F20	1	20/40 A	1 module per axis	6SC6120-0FE80
A30, E30, H30, F30	1	30/60 A	1 module per axis	6SC6130-0FE80
A40, E40, H40, F40	1	40/80 A	1 module per axis	6SC6140-0FE80
A70, E70, H70, F70	1	70/140 A	2 modules per axis	6SC6170-0FC80
A90, E90, H90, F90	1	90/180 A	3 modules per axis	6SC6190-0FB80
A92, E92, H92, F92	1	120/240 A	3 modules per axis**)	6SC6190-0FB86

*) A ≙ Installed H ≙ Design for main spindle operation (installed)
 E ≙ Installation prepared F ≙ Prepared for main spindle operation
 **) only available in the 440 mm casing

1.3.1.3 Options

Designation	Notes	Expansion set
G10*)	Link-circuit voltage limitation 0.3/30 kW (continuous/short-time rating)	6SC6100-0AA81
G20*)	Link-circuit voltage limitation 0.9/90 kW (continuous/short-time rating)	6SC6100-0AB80
B11 B12 B13 B14 B15 B16	Terminal strip for connecting power cables with cross-sections exceeding those laid down by DIN VDE 0100 (depending on casing width)	6SC6101-0SA20
D01	Standstill monitoring	6SC6100-0DA80
D02	Axis-specific individual fault indications	6SC6100-0NC80 6SC6100-0NC81 6SC6100-0NC82

1.3.2 Ordering data overview 6SC6101-.B-Z

1.3.2.1 Casing

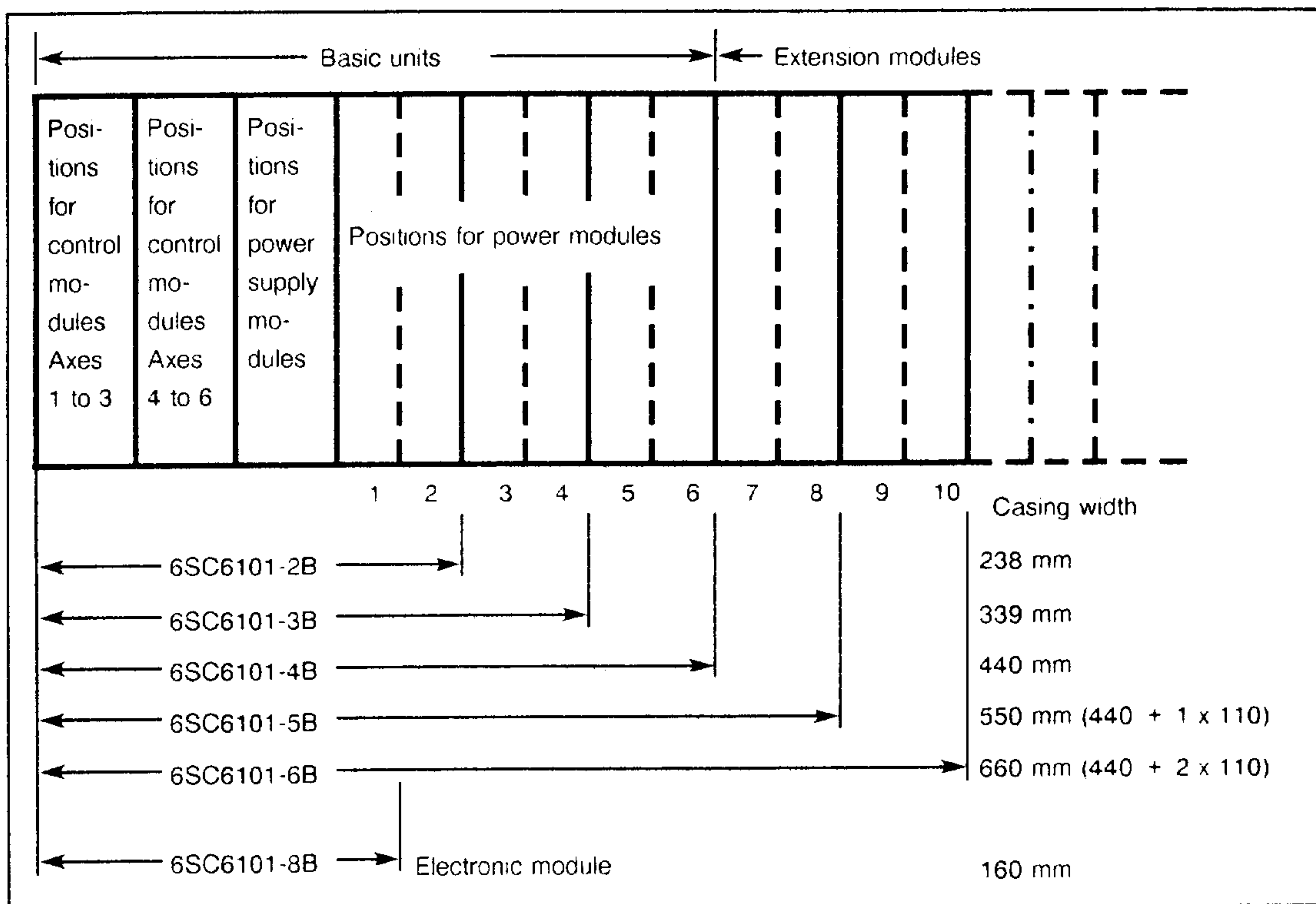

Fig. 1.3 Casing

*) G10 and G20 may not be operated in parallel

1.3.2.2 Power modules

Designation	Number of axes	Current I_N/I_{max}	Notes	Expansion set
A13 A23 A33	1 2 3	3/6 A	1 axis on one module 2 axes on one module 3 axes on one module	6SC6103-0SE80 6SC6103-0SG80 6SC6103-0SN80
A18 A28 A38	1 2 3	8/16 A	1 axis on one module 2 axes on one module 3 axes on one module	6SC6108-0SE80 6SC6108-0SG80 6SC6108-0SN80
A20	1	20/40 A	1 module per axis	6SC6120-0FE80
A30	1	30/60 A	1 module per axis	6SC6130-0FE80
A40	1	40/80 A	1 module per axis	6SC6140-0FE80
A70	1	70/140 A	2 modules per axis	6SC6170-0FC80
A90	1	90/180 A	3 modules per axis	6SC6190-0FB80
A92	1	120/240 A	3 modules per axis*)	6SC6190-0FB86
A99	1	200/400A	6 modules per axis*)	Cannot be retrofitted

1.3.2.3 Controls

Designation	Number of axes	Notes	Expansion set
N11, N21 N12, N22 N13, N23	1 2 3	Analog control 1 axis on one module 2 axes on one module 3 axes on one module	6SC6100-0NA80 6SC6100-0NA81 6SC6100-0NA82
M11, M21 M12, M22 M13, M23	1 2 3	Analog control with individual fault indication 1 axis on one module 2 axes on one module 3 axes on one module	6SC6100-0NC80 6SC6100-0NC81 6SC6100-0NC82
K11 K12 K13	1 2 3	Analog control with resolver evaluation with SSI interface 2 modules 2 modules 2 modules	6SC6100-0NB80 6SC6100-0NB81 6SC6100-0NB82

1.3.2.4 Link circuit

Designation	Link-circuit voltage	Power	Notes
V00	DC 300 V	–	Unit prepared for operation with controlled input/feedback
V12	DC 210 V	15 kW	Rectifier
V15	DC 210 V	20 kW	Rectifier
V25	DC 210 V	40 kW	Rectifier

*) only available in 440 mm casing

1.3.2.5 Options

Designation	Notes	Expansion set
G10 ^{*)}	Link-circuit voltage limitation 0.3/30 kW (continuous/short-time rating)	6SC6100-0AA81
G20 ^{*)}	Link-circuit voltage limitation 0.9/90 kW (continuous/short-time rating)	6SC6100-0AB80
A00	Adapter 2 × 16-way to 1 × 34-way	6SC6101-0LA13
B11	Terminal strip for connecting power cables with cross-sections greater than laid down in DIN VDE 0100 (depending on casing width)	6SC6101-0SA20
B12		
B13		
B14		
B15		
B16		

1.3.3 Rated data

Rated supply voltage	3 AC 50/60 Hz 165 V or DC 220 V ^{**)} + 10 %, - 15 % DC 300 V regulated by SIMODRIVE 290
Rated output voltage	3 AC 210 V 3 AC, 300 V with SIMODRIVE 290
Short-time limit current	2 × I _N (200 ms)
Efficiency	Approx. 95 %
Number of feed axes	1 to 6
Power loss P _V	P _V ≈ 0.05 × P
Permissible ambient temperatures	
• Inlet air temperature	0 °C to +60 °C (also refer to Fig. 1.5)
• Storage temperature	- 25 °C to +85

P ≙ Power supplied to a load under
typical feed drive conditions
I_N ≙ Rated current

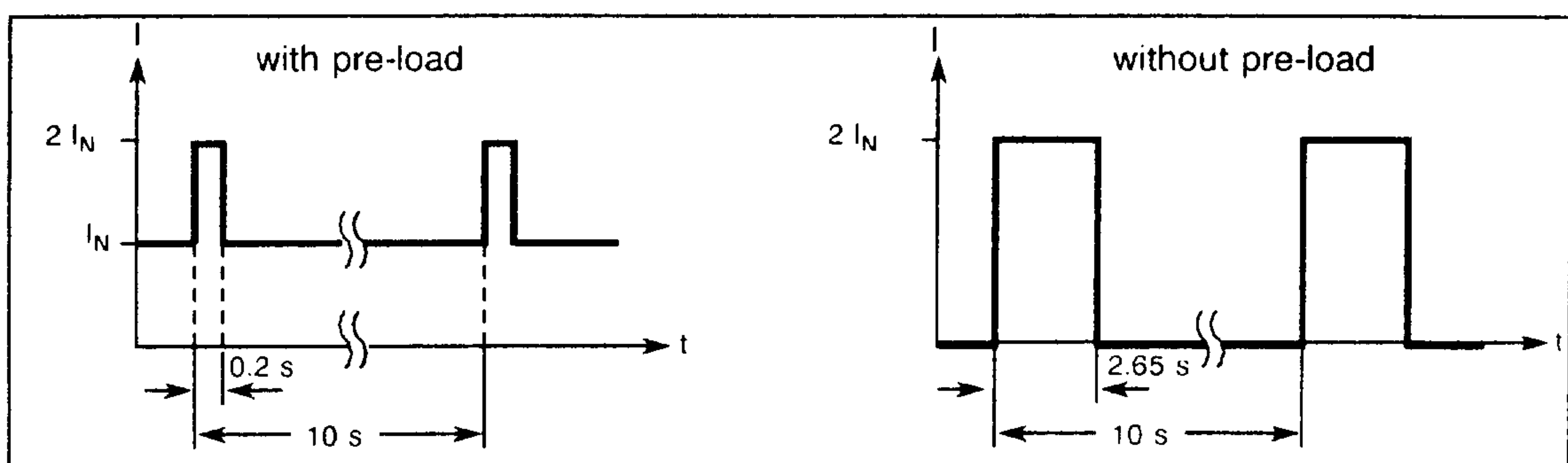

Fig. 1.4 Rated load cycles for power module in operation with short-time limit current

^{*)} G10 und G20 may not be operated in parallel

^{**)} With direct supply via P200 and M200

1.3.3 Rated data

In operation without short-time limit current, a continuous current of 1.1 times the rated current is permissible (also see Section 3.1.14).

Having checked the capacity of the power modules listed above, the maximum permissible open circuit currents during drive stand-still for the power modules are listed below:

Power module	3 A	max. open circuit current	100 %	=	3 A
Power module	8 A	max. open circuit current	100 %	=	8 A
Power module	20 A	max. open circuit current	100 %	=	20 A
Power module	30 A	max. open circuit current	80 %	=	24 A
Power module	40 A	max. open circuit current	80 %	=	32 A
Power module	70 A	max. open circuit current	80 %	=	56 A
Power module	90 A	max. open circuit current	85 %	=	76,5 A
Power module	120 A	max. open circuit current	65 %	=	78 A
Power module	200 A	max. open circuit current	75 %	=	150 A

max. permissible open circuit currents for SIMODRIVE-power modules, 6SC61

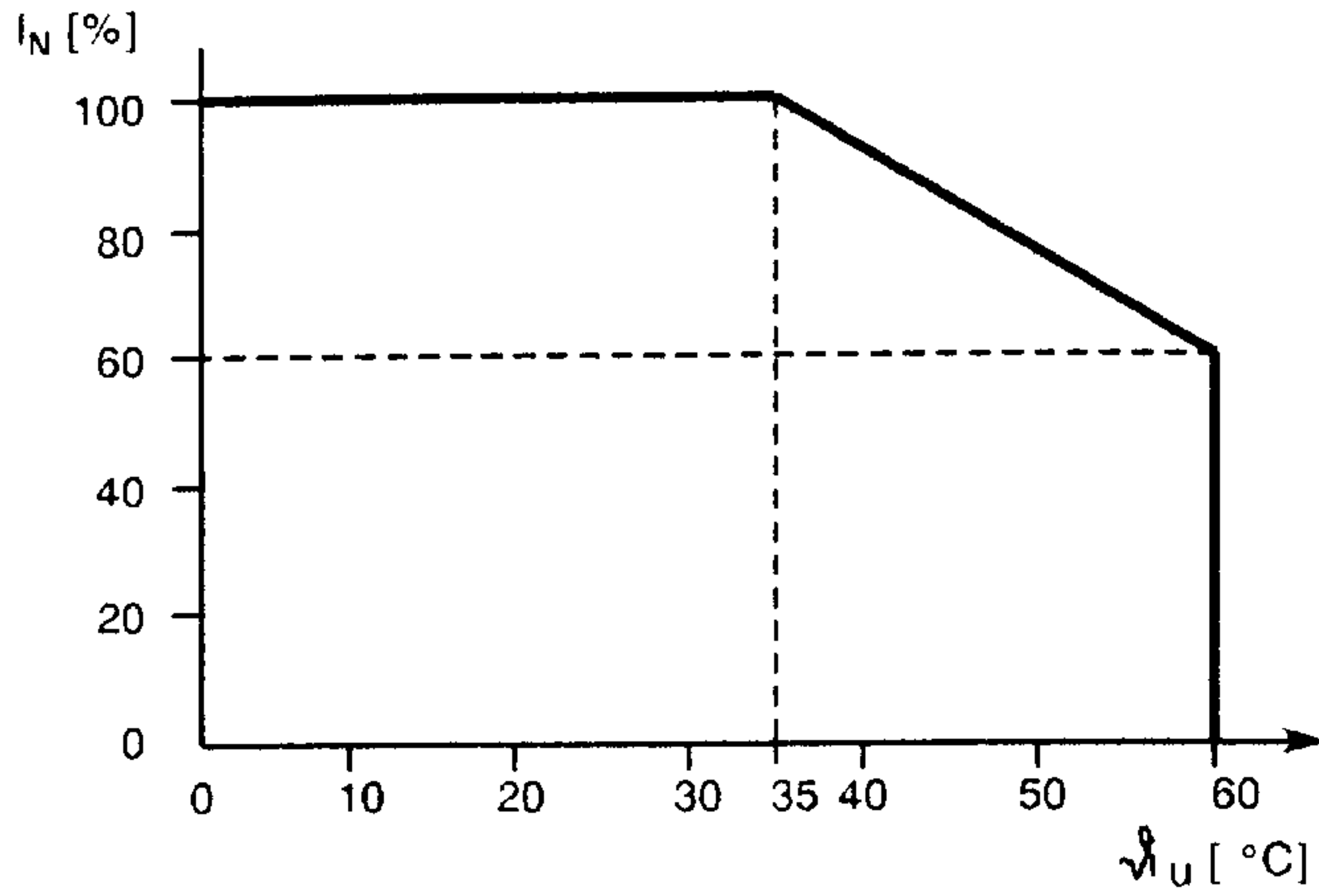

Fig. 1.5 Power reduction with raised inlet air temperature

Site altitude: The load values indicated are valid for site altitudes up to 1000 m a.s.l. Derating according to the curve below is necessary for site altitudes beyond 1000 m.

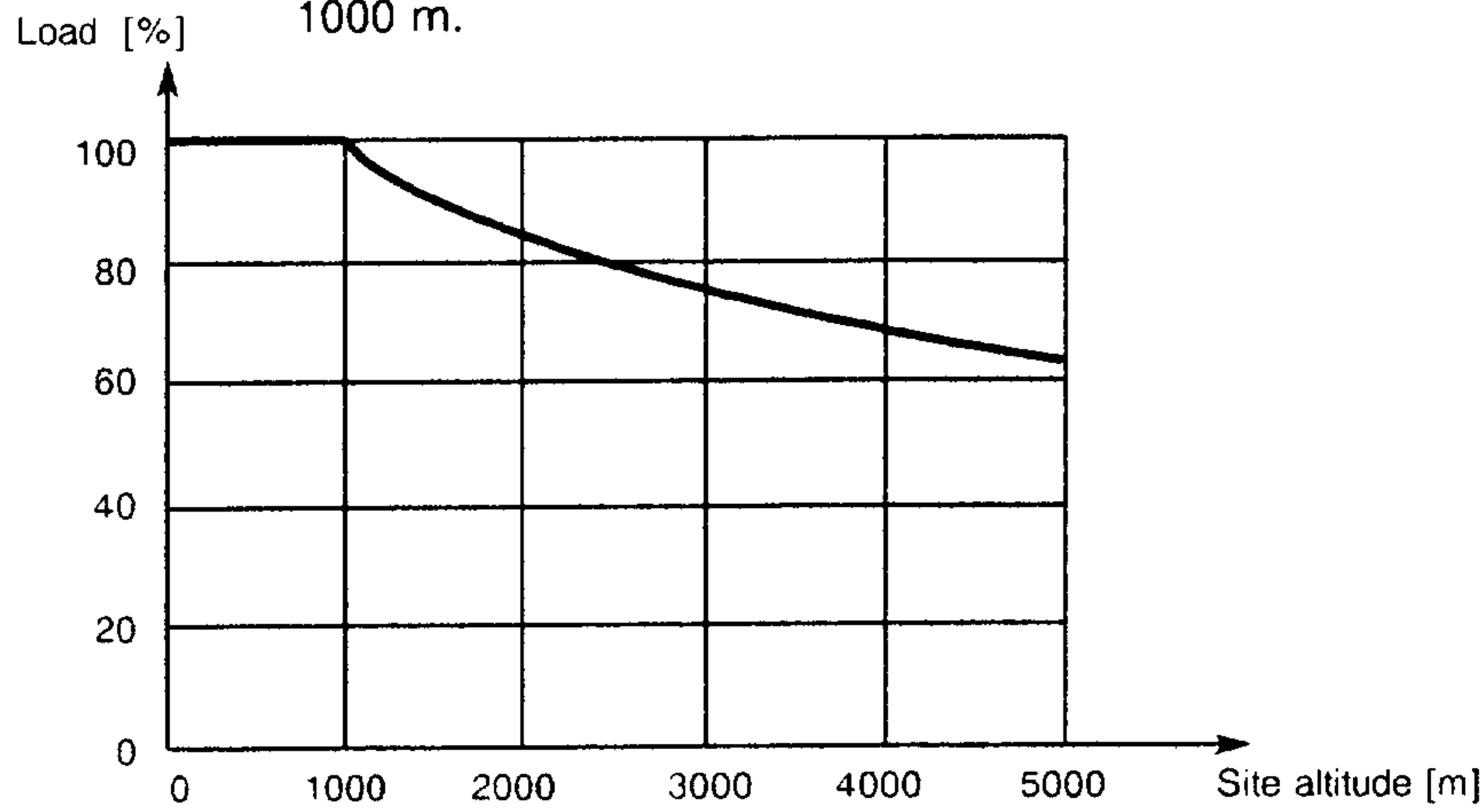

Fig. 1.6 Power reduction with side altitudes > 1000 m a.s.l.

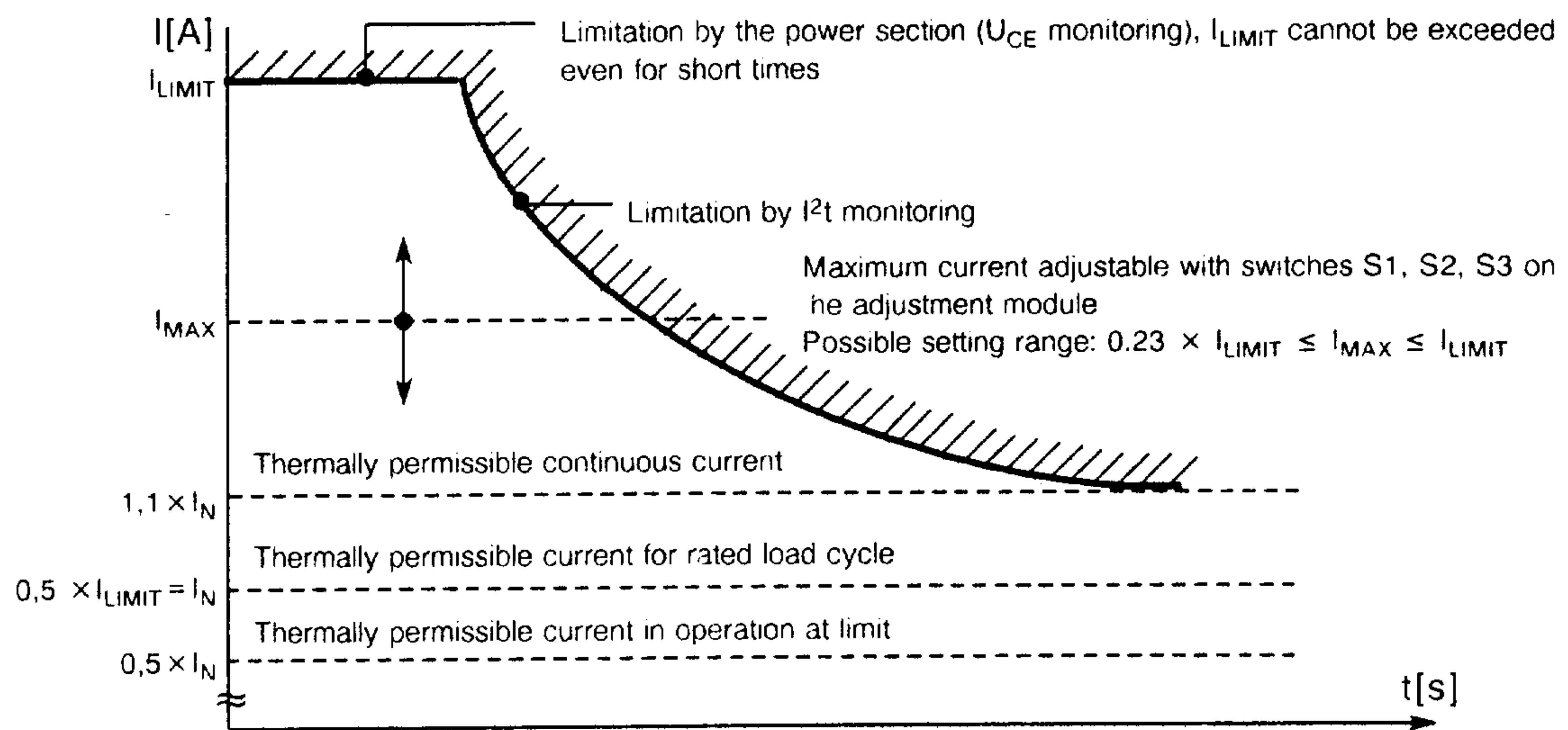

Fig. 1.7 Effective current limits

2 Installation

2.1 Installation of units

A minimum clearance of 100 mm must be available above and below the units to ensure unobstructed air supply.

The equipments must be mounted such that they are protected from in flammable and conducting dust and steam (degree of protection DIN 40050-IP00).

For mounting dimensions and location of the fixing points refer to the dimension drawings.

NOTE

- The front cover provides protection against contact with live parts according to DIN VDE 0106, Part 7.
- The unit's internal power supply for the fans is not isolated from the mains supply.

2.2 Connecting instructions

The units are connected to the mains via an autotransformer or an isolating transformer. When an isolating transformer is used, M200 on the power module must be earthed. Depending on the transformer and unit size, an inrush current limiting circuit must be provided if necessary (see Section 2.3 "Inrush current limitation").

	Rating of mains fuse	Line protection	Fuse characteristic
Operation without inrush current limitation	6-times transformer rated current	Not obtained	Time-lag
Operation with inrush current limitation	1.3-times transformer rated current	Obtained	Time-lag

Table 2.1

Connect the units as recommended by manufacturer and in accordance with the circuit diagram supplied by the customer. The current limiting circuit, the tacho input and the current controller gain of the unit must be matched to the type of motor used. For details refer to Section 3.1 "Matching the control system".

NOTE

- The reference and actual value cables must be shielded and installed separately from the power cables.
- Twisted leads are recommended for the motor conductors.
- The control cables for the controller enabling circuits must be installed separate from the contactor control cables.

The chassis earth connection between the NC and the PWM drive should be kept as short as possible using minimum conductor cross-sections of 4 mm². Connect terminal +G0-X131 to the NC earthing point or, in systems without an NC, to earth.

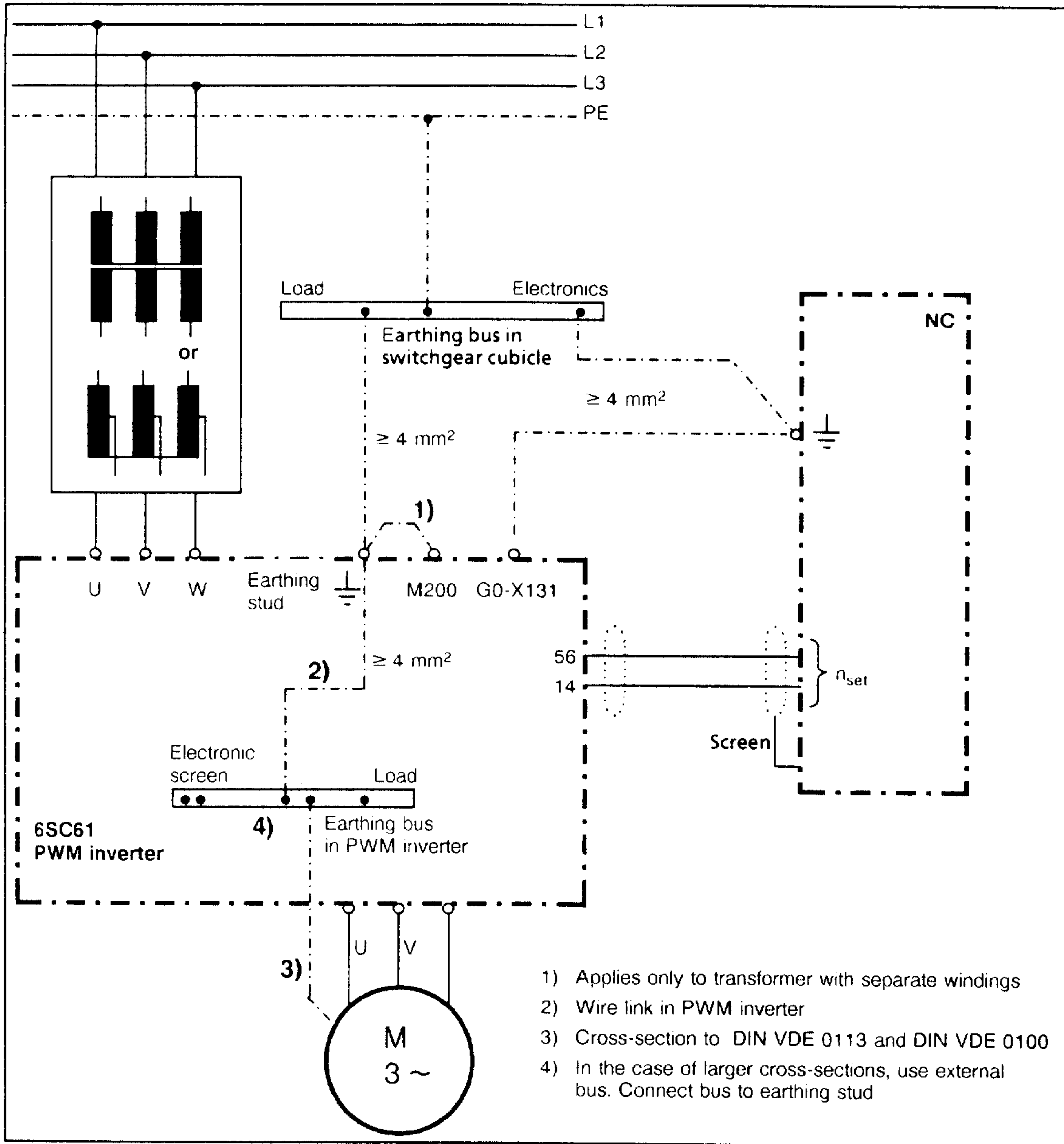

Fig. 2.1 Earthing concept

2.3 Inrush current limitation

Depending on the necessary power or the matching transformer and the size of the rectifier (see table 2.2), an inrush current limiting circuit with resistors is to be set up.

If inrush current limitation is required, this should be installed as shown in connection diagram 462 012.9600.00 KL Sheet 2 (Section 6).

Rectifier	V12	V15	V25
Auto-transformer	2,5 kVA	5 kVA	5 kVA
Isolating transformer	5 kVA	10 kVA	10 kVA

Table 2.2 Maximum power of matching transformer without inrush current limiting as a function of the rectifier size

2.4 Connecting cable between motor and PWM inverter (sensor cable)

Maximum cable length about 50 m. Cable lengths of up to 100 m are possible, but may adversely affect the dynamic response and the smoothness of running at very low speeds.

Connector at 1FT5 motor end

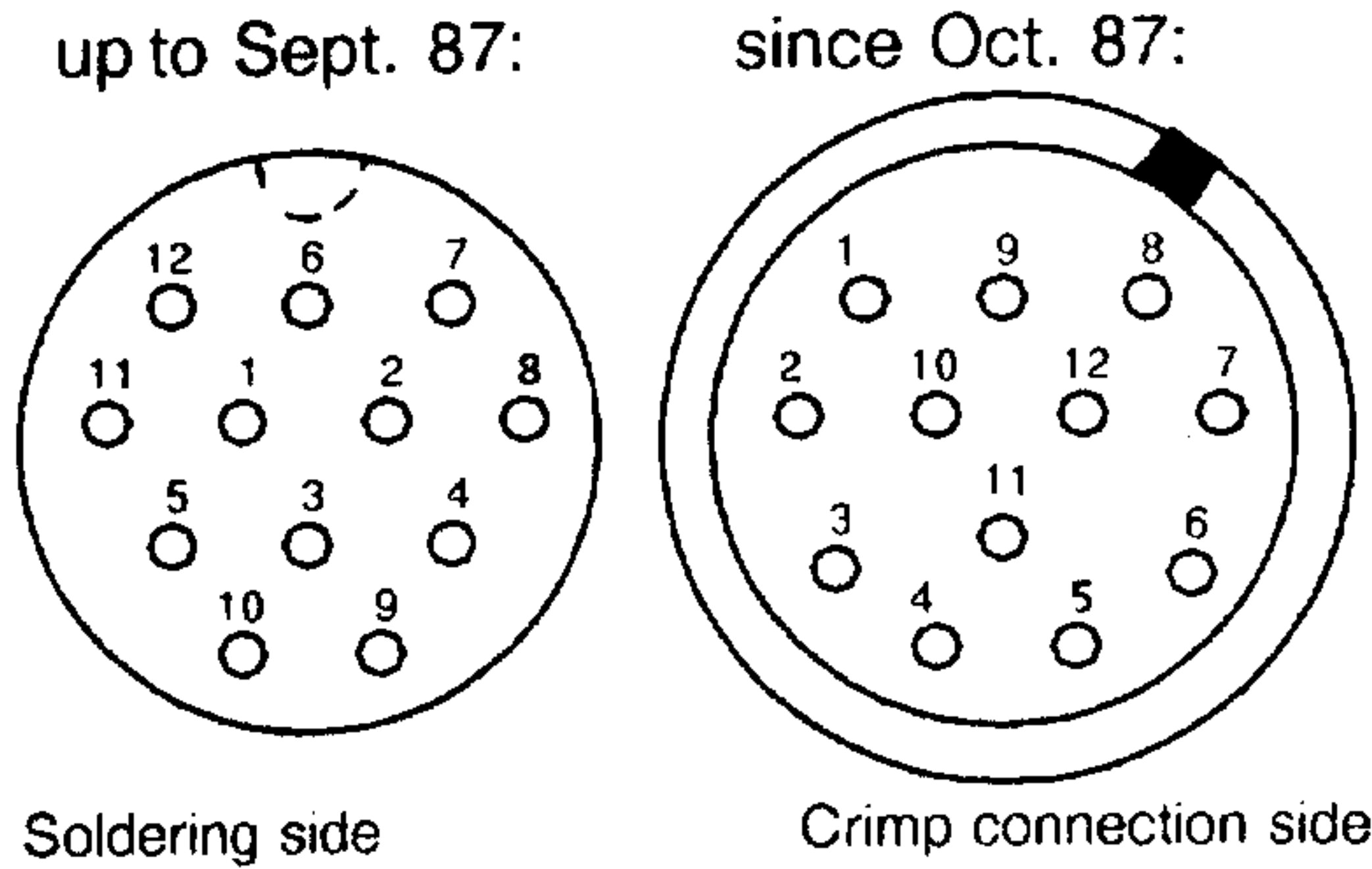

Soldering side

Crimp connection side

Connector: BS 12 K
Messrs. Euchner
Order No.: 6FC 9348-7AC

Connector:
Messrs. Siemens
Order No.: 6FC 9348-7AD

Connector at 6SC61 inverter end
+ N₀ - X311/- X321/- X331

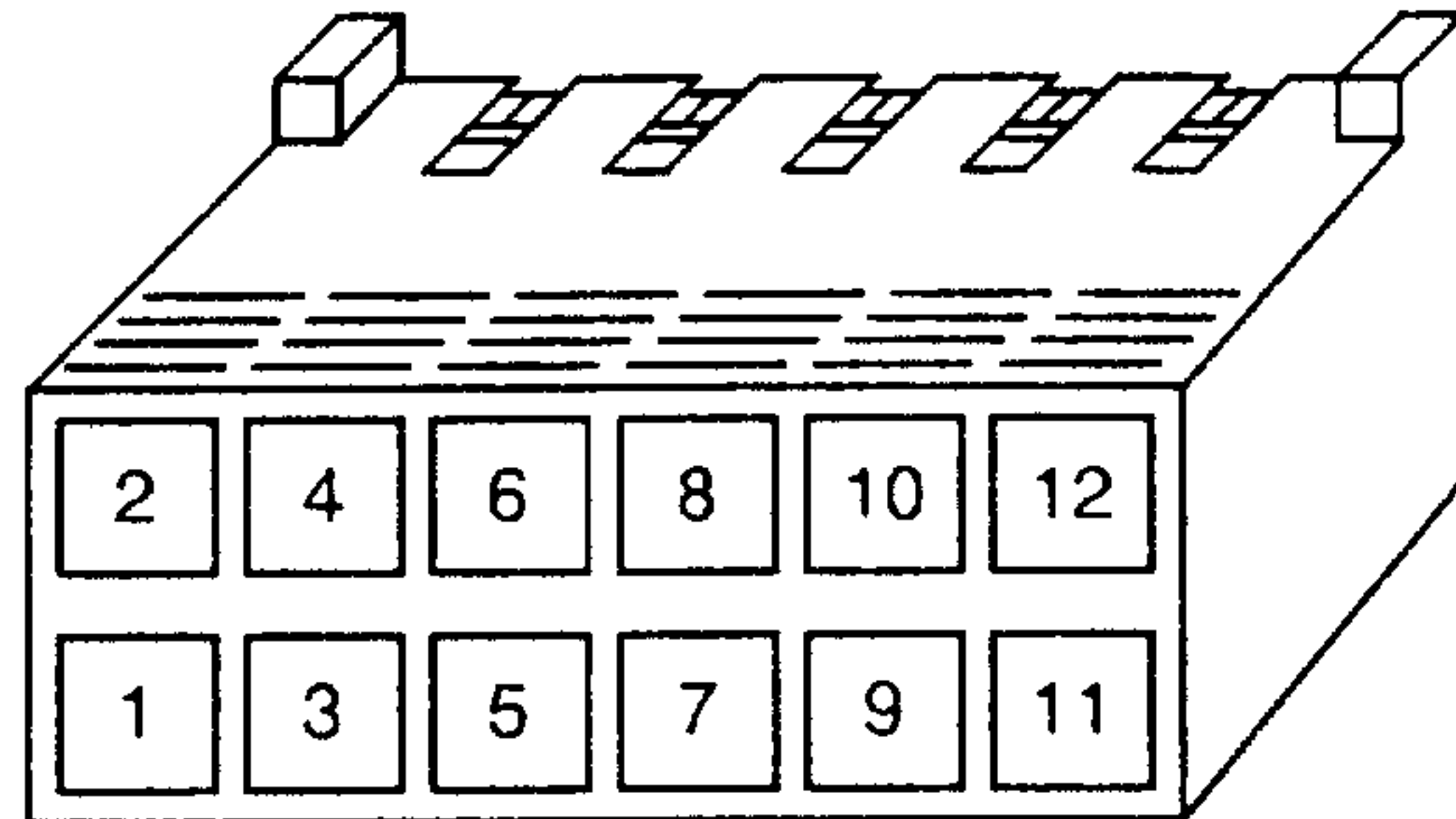

Crimp connection side

Connector casing:
DUBOX 65239-006 Messrs. Du Pont
Order No.: 6FC 9348-7AB (with 12 crimp contacts)

Crimp tools:
HT234 hand tool for contacts supplied loose
Messrs. Du Pont
Order No.: 6FC 9348-8AA
HT250/HT251 hand tool for contacts supplied on tape
Messrs. Du Pont
Order No.: 6FC 9348-8AB

Crimp contacts:
76357-401 (contacts supplied loose) Messrs. Du Pont
Order No.: 6ZY1074-0AA00
76347-403 (contacts supplied on tape) Messrs. Du Pont
76347-403 (contacts supplied on tape) can also be handled with the crimping pliers for HT234 contacts (supplied loose), once the crimp contacts have been taken off the tape.

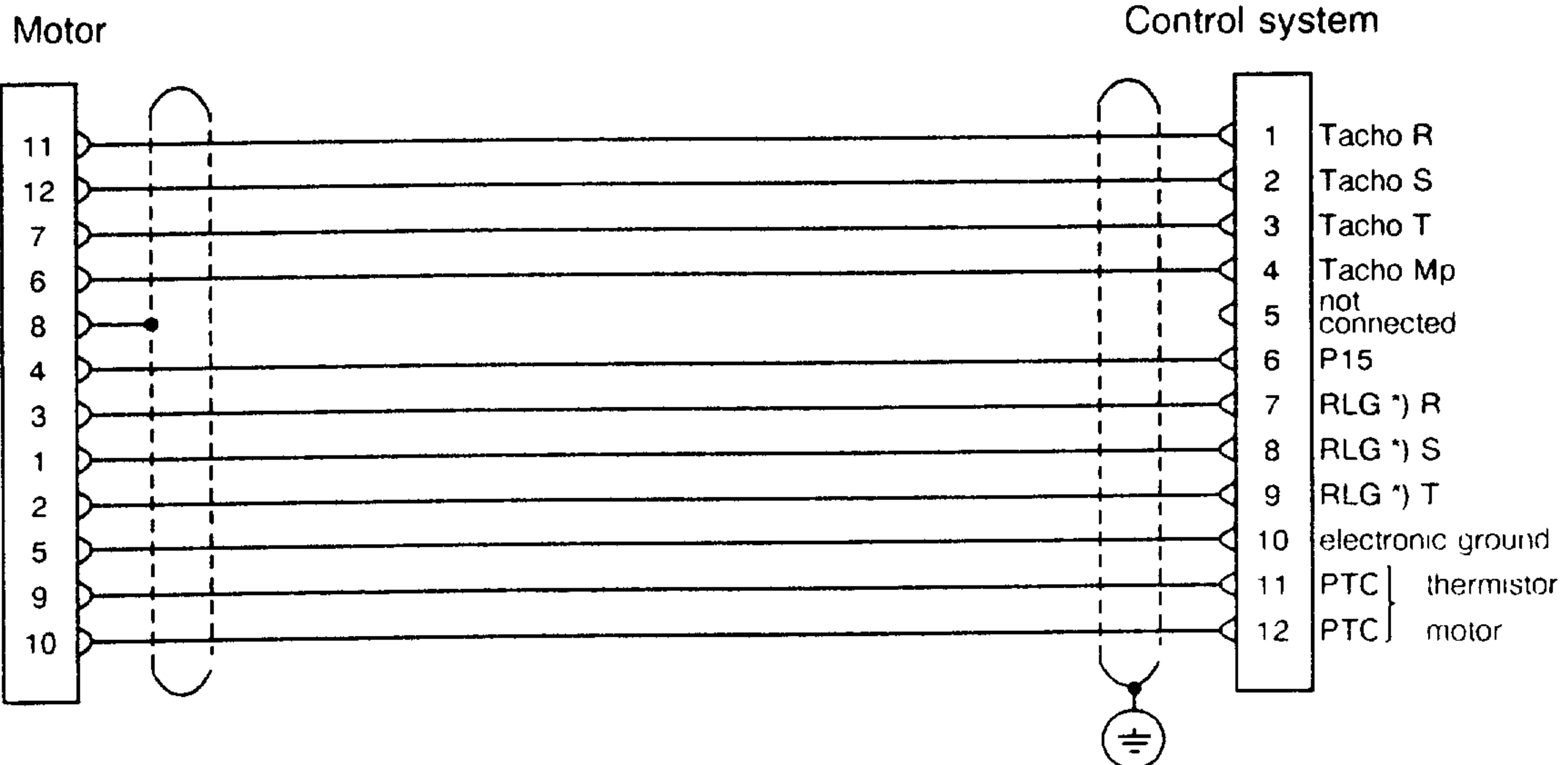

For screen connection and strain relief, see Section 2.5

Sensor cable 12 x 0.23 mm², screened, with connectors
Cable by the metre without connectors

Order No.: 6FC9348-5B.
Order No.: 6FC9348-6AA

*) RLG = shaft-position encoder

2.5 Screen connection and strain relief of cables

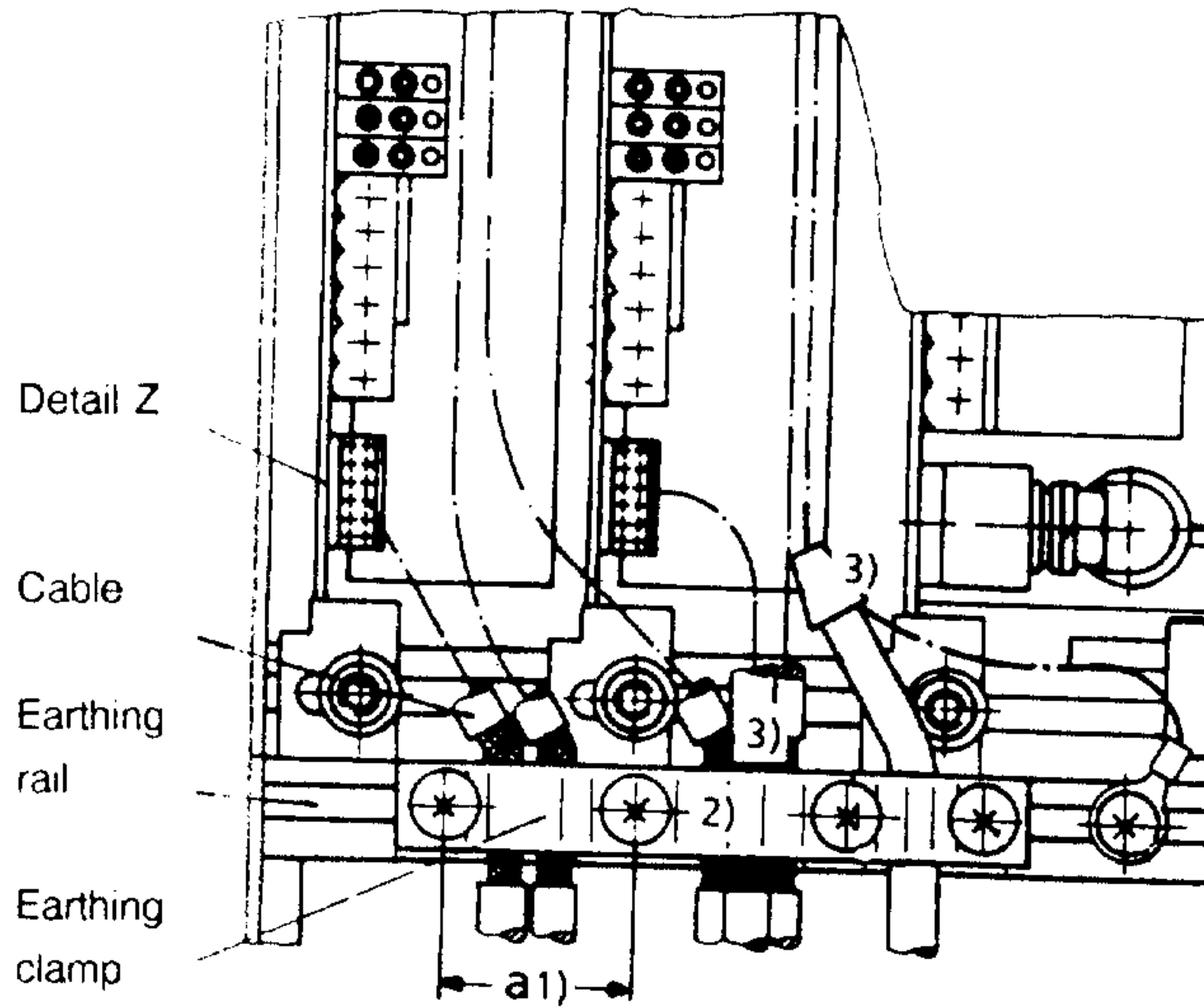

- 1) One to three cable screens can be connected, depending on distance a between screws
- 2) **Important!** Screen of setpoint cables from NC must not be connected to chassis earth
- 3) Alternative method of connecting the cable screens

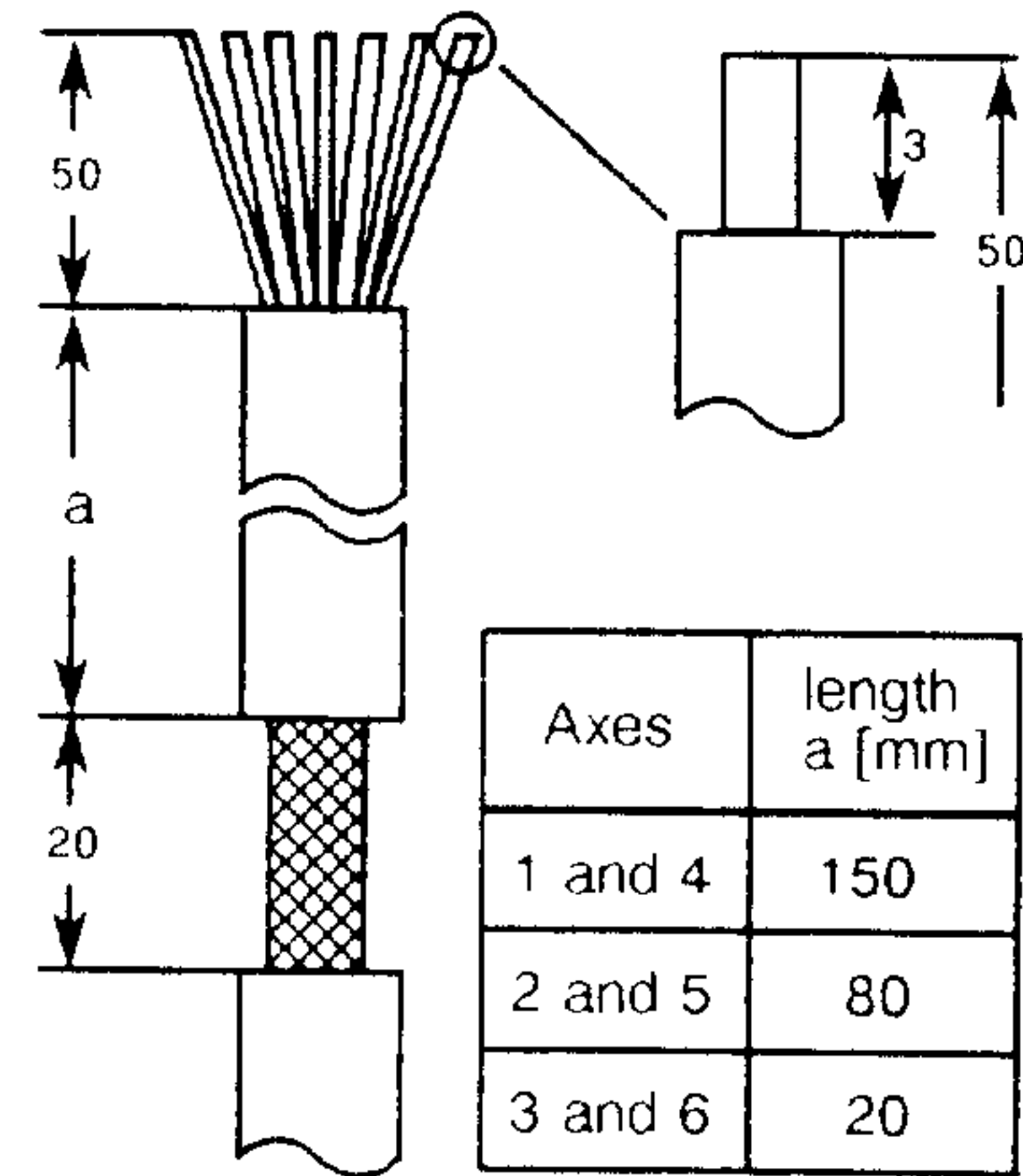

Insulation stripped for earthing of cable screen and strain relief

Detail Z

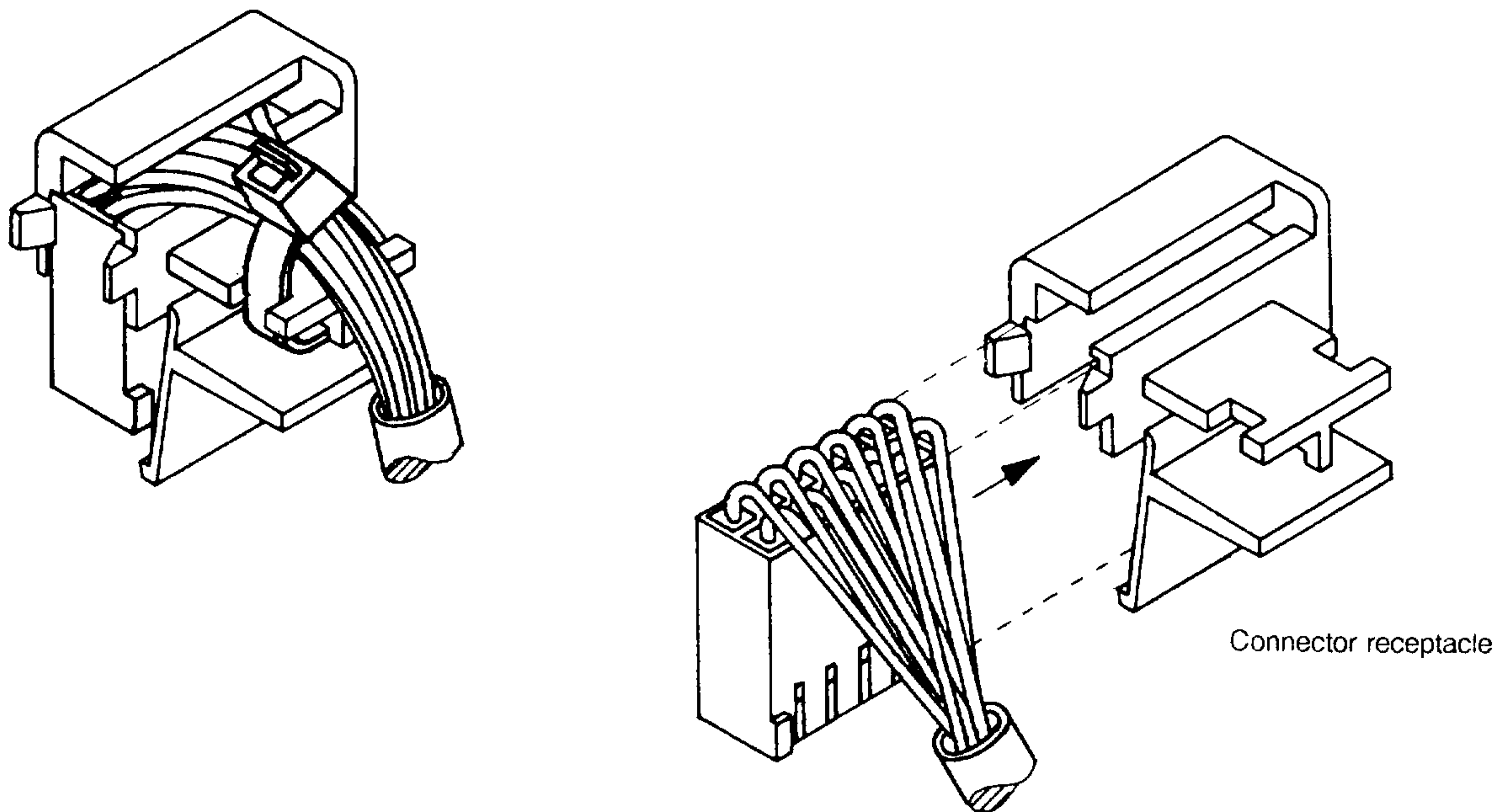

Set of screen earthing parts, Order No.: 6SC6101-0SB01

The connector receptacle is included in the set of connection parts supplied with the control electronics for 1 axis.

2.6 Terminals

Terminal	Location	Function	Type (***)	Typical voltage	Maximum permissible conductor cross-section
----------	----------	----------	---------------	-----------------	---------------------------------------------

Power section

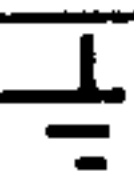
U, V, W	-	Mains connection	E	165 V 3 CA	Terminal for M8 **)
	-	PE conductor	E	0 V	Terminal for M8 **)
M200 busbar	-	With isolating transformer only Connection to frame	E	0 V	Terminal for M6 **)
		Motor connections 3/6 A, 8/16 A 20/40 A, 30/60 A, 40/80 A 70/140 A, 90/180 A, 120/240 A, 200/400 A	A	210 V 3 CA	1.5 mm ² 16 mm ² 25 mm ² Terminal for M6 **)

Supply voltages

7	+G0-X111	Auxiliary voltage (+ 18 - 30 V)	A	+ 24 V, 50 mA max.	1.5 mm ²
10	+G0-X111	Auxiliary voltage (- 18 - - 30 V)	A	- 24 V, 50 mA max.	1.5 mm ²
45	+G0-X111	Electronics voltage	A	+ 15 V, 10 mA max.	1.5 mm ²
44	+G0-X111	Electronics voltage	A	- 15 V, 10 mA max.	1.5 mm ²
9, 19	+G0-X121	Enabling voltage	E/A	± 24 V, 0 V	1.5 mm ²
11	+G0-X111	External auxiliary voltage	E	± 24 V, 1 A (***)	1.5 mm ²
15	+G0-X111 +G0-X131	Elec. ground } internally Ref. earth } connected	A E/A	0 V 0 V	1.5 mm ² Terminal for M6 **)

Electronic signals

R	+G0-X111	Fault latch reset	E	0 V	1.5 mm ²
56, 14	+N ₀ -X1 ₀ ,1	Speed setpoint I	E	± 10 V	1.5 mm ²
24, 8	+N ₀ -X4 ₀ ,1	Speed setpoint II	E	± 10 V	1.5 mm ²
6	+N ₀ -X1 ₀ ,1	Integrator blocking	E	+ 15 V	1.5 mm ²
96	+N ₀ -X1 ₀ ,1	External current limit reduction	E	- 15 V	1.5 mm ²
63	+G0-X121	Pulse enabling	E	+ 12 V ã + 30 V	1.5 mm ²
64	+G0-X121	Drive enabling	E	+ 12 V ã + 30 V	1.5 mm ²
65	+N ₀ -X1 ₀ ,1	Speed controller enabling	E	+ 12 V ã + 30 V	1.5 mm ²
16	+N ₀ -X4 ₀ ,1	Actual current value	A	± 10 V (R _i = 2 kΩ)	1.5 mm ²
58	+N ₀ -X4 ₀ ,1	Current setpoint	E	± 10 V	1.5 mm ²

Messages

5	+G0-X111	$I^2t \geq$ and/or V_{Motor}	A	0 V, 50 mA	1.5 mm ²
74, 73.1*) (NC) 72, 73.2*) (NO)	+G0-X121	Relay contact, drive fault/ready signals	A	250 V CA, 5 A 30 V CC, 5 A	1.5 mm ²

Table 2.3

N₀ ã N1, N2 X1₀,1 ã X111, X121, X131 X4₀,1 ã X411, X421, X431

*) Terminals 73.1 and 73.2 are electrically interconnected via a 0 Ω resistor

***) For cable lugs to DIN 46234

****) Tolerance : + 19 V to 30 V (see Chapter 3.1.9)

****) E ã Input A ã Output

3 Commissioning

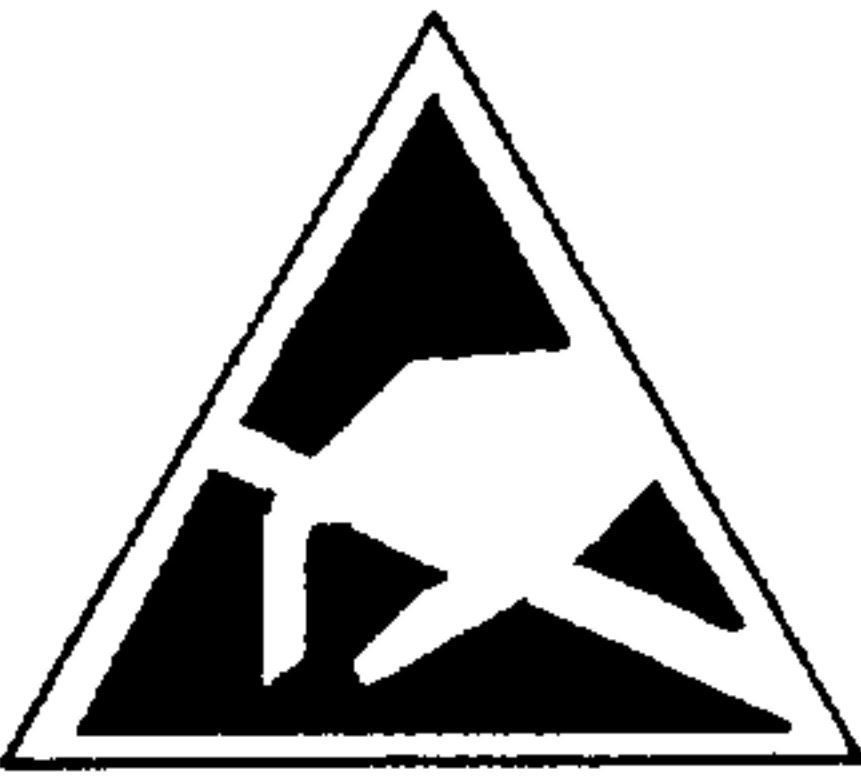
 	WARNING
	<p>The successful and safe operation of this equipment is dependent on proper handling, installation, operation and maintenance.</p> <p>Non-observance of the safety instructions can result in severe personal injury or property damage.</p> <p>The modules include electrostatically sensitive devices. Before touching a PCB, the person carrying out the work must himself be electrostatically discharged. The simplest way of accomplishing this is to touch an electrically conducting earthed object (e.g. a bare metal part of a switchboard or the PE contact of a socket outlet).</p>

3.1 Matching the control system

3.1.1 Matching the tacho voltage

The tacho input circuit of the unit is designed for a tacho voltage of 30 to 40 V at rated motor speed. Short-circuit jumpers must therefore be inserted on the controller module for motors with a lower tacho voltage (11 V, 16.5 V). The jumpers are supplied as part of the connection accessories for the control electronics for 1 axis.

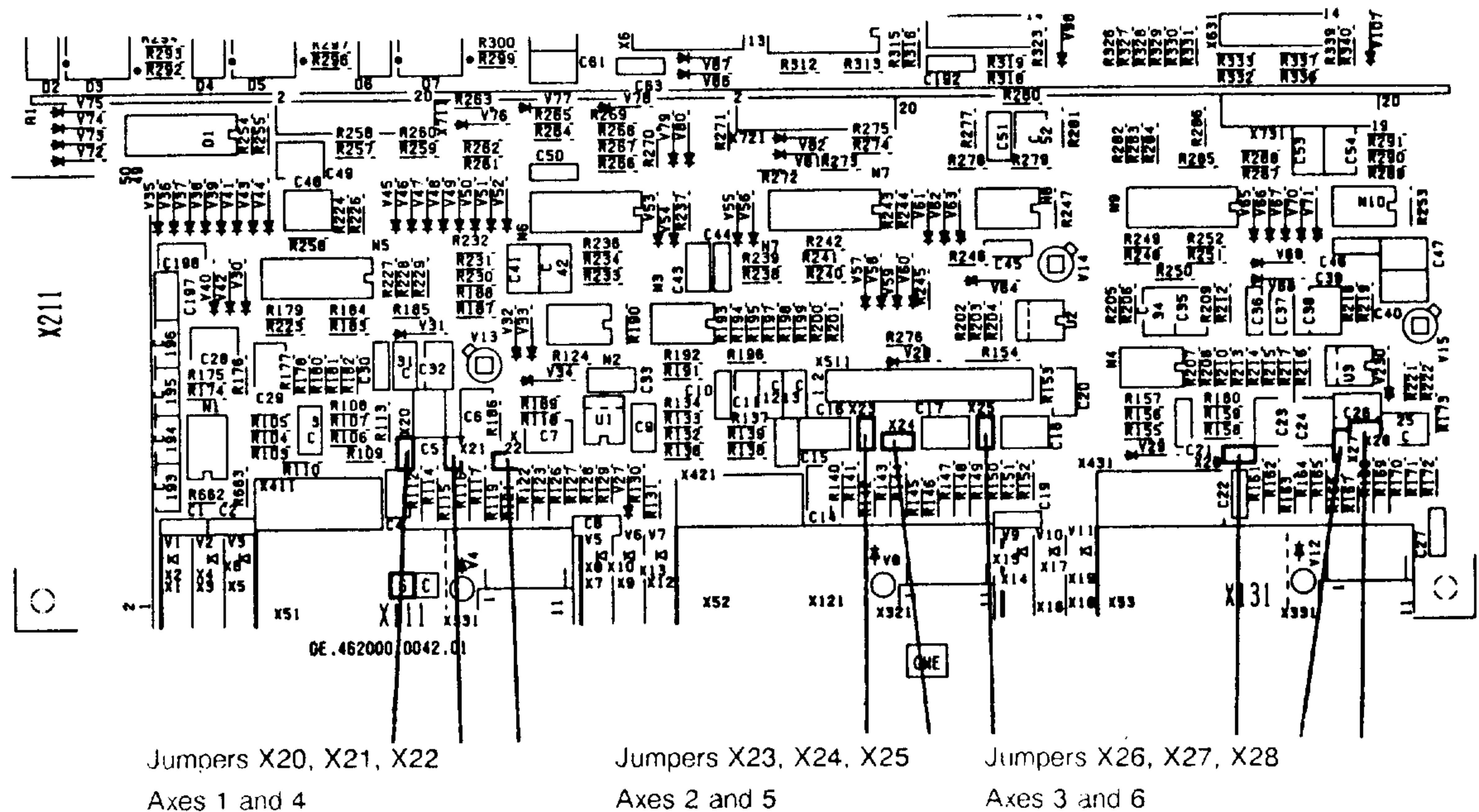

Fig. 3.1 Position of short-circuit jumpers on the controller module

3.1.1 Matching the tacho voltage

Motor type	Rated speed in rev/min	Tacho voltage at rated speed	Insert short-circuit jumpers			Actual-speed value at rated speed Test socket X
			Axes 1 and 4	Axes 2 and 5	Axes 3 and 6	
1FT502. -0AC01	2000	11 V	X20, X21, X22	X23, X24, X25	X26, X27, X28	7.33 V
to -0AF01	3000	16.5 V	X20, X21, X22	X23, X24, X25	X26, X27, X28	11 V
1FT504. -0AH01	4500	30 V	-	-	-	7.5 V
-0AK01	6000	40 V	-	-	-	10 V
1FT506. -0AA01	1200	40 V	-	-	-	10 V
to -0AC01	2000	40 V	-	-	-	10 V
1FT513. -0AF01	3000	40 V	-	-	-	10 V
-0AG01	4000	40 V	-	-	-	10 V
-0AK01	6000	40 V	-	-	-	10 V

Table 3.1

3.1.2 Matching tables for motor/pulse-width-modulated inverter

Matching table for SIMODRIVE power modules **6SC6103-...** (3/6A)

Short designation A13, A23, A33, H13, H23, H33

Settings by means of switches S1, S2 and S3 on the adjustment module.

Servo motor				Current limit					Current controller				
1FT	M _o [Nm]	I _o [A]	n _{rated} [rev/min]	Contacts				I _{max} [A]	Contacts				Kp (l)
				2	3	4	5		6	7	8	9	
5020-0AC01	0.15	0.56	2000	o	o	o	x	2.2	o	x	o	o	2.0
5020-0AF01	0.15	0.63	3000	o	x	x	o	2.5	x	o	o	o	1.0
5020-0AH01	0.15	0.68	4500	x	o	x	o	2.8	x	o	o	o	1.0
5020-0AK01	0.15	0.71	6000	x	o	x	o	2.8	x	o	o	o	1.0
5022-0AC01	0.27	0.9	2000	x	x	o	o	3.6	o	x	o	o	2.0
5022-0AF01	0.27	1.05	3000	o	x	o	o	4.0	o	x	o	o	2.0
5022-0AH01	0.27	1.2	4500	o	x	o	o	4.0	x	o	o	o	1.0
5022-0AK01	0.27	1.3	6000	x	o	o	o	5.2	x	o	o	o	1.0
5024-0AC01	0.4	1.2	2000	o	x	o	o	4.0	o	x	o	o	2.0
5024-0AF01	0.4	1.45	3000	o	o	o	o	6.0	o	x	o	o	2.0
5024-0AH01	0.4	1.6	4500	o	o	o	o	6.0	x	o	o	o	1.0
5024-0AK01	0.4	1.8	6000	o	o	o	o	6.0	x	o	o	o	1.0
5032-0AC01	0.25	0.75	2000	x	o	x	o	2.8	o	x	o	o	2.0
5032-0AF01	0.25	0.95	3000	x	x	o	o	3.6	o	x	o	o	2.0
5032-0AH01	0.25	1.1	4500	o	x	o	o	4.0	o	x	o	o	2.0
5032-0AK01	0.25	1.2	6000	o	x	o	o	4.0	o	x	o	o	2.0
5034-0AC01	0.5	1.3	2000	x	o	o	o	5.2	o	o	x	o	4.0
5034-0AF01	0.5	1.7	3000	o	o	o	o	6.0	o	x	o	o	2.0
5034-0AH01	0.5	2.1	4500	o	o	o	o	6.0	o	x	o	o	2.0
5034-0AK01	0.5	2.4	6000	o	o	o	o	6.0	x	o	o	o	1.0
5036-0AC01	0.75	1.8	2000	o	o	o	o	6.0	o	o	x	o	4.0
5036-0AF01	0.75	2.4	3000	o	o	o	o	6.0	o	x	o	o	2.0
5036-0AH01	0.75	3.1	4500	o	o	o	o	6.0	x	o	o	o	1.0
5036-0AK01	0.75	3.6	6000	o	o	o	o	6.0	x	o	o	o	1.0
5042-0AC01	0.6	1.4	2000	x	o	o	o	5.2	o	o	x	o	4.0
5042-0AF01	0.6	1.9	3000	o	o	o	o	6.0	o	x	o	o	2.0
5042-0AH01	0.6	2.5	4500	o	o	o	o	6.0	o	x	o	o	2.0
5042-0AK01	0.6	3.0	6000	o	o	o	o	6.0	x	o	o	o	1.0
5044-0AC01	1.2	2.5	2000	o	o	o	o	6.0	o	x	o	o	2.0
5044-0AF01	1.2	3.5	3000	o	o	o	o	6.0	x	o	o	o	1.0
5046-0AC01	2.0	3.3	2000	o	o	o	o	6.0	o	x	o	o	2.0
5061-0AC01	1.2	3.3	2000	o	o	o	o	6.0	o	o	x	o	4.0
5061-0AF01	1.2	4.6	3000	o	o	o	o	6.0	o	x	o	o	2.0
5062-0AC01	2.2	3.5	2000	o	o	o	o	6.0	o	o	x	o	4.0

Table 3.2

o ≙ Contact in initial position (OFF)

x ≙ Contact in ON position

Contacts S1.1, S2.1, S3.1: Reversal

Contact S1.10/resistor R200: Contact S1.10 in ON position/R200 provided in the form of a jumper:
The three axes are operated in current loop

Separately-ventilated motors can be used instead of the non-ventilated motors.

- 0A.01 ≙ non-ventilated motor
- 0S.01 ≙ separately-ventilated motor

Matching table for SIMODRIVE power modules **6SC6108-...** (8/16A)

Short designation A18, A28, A38, H18, H28, H38

Settings by means of switches S1, S2 and S3 on the adjustment module.

Servo motor				Current limit					Current controller				
1FT	M _o [Nm]	I _o [A]	n _{rated} [rev/min]	Contacts				I _{max} [A]	Contacts				Kp (l)
				2	3	4	5		6	7	8	9	
5022-0AC01	0.27	0.9	2000	x	x	x	x	3.6	o	x	o	o	2.0
5022-0AF01	0.27	1.05	3000	o	o	x	x	4.2	o	x	o	o	2.0
5022-0AH01	0.27	1.2	4500	o	x	o	x	4.8	x	o	o	o	1.0
5022-0AK01	0.27	1.3	6000	x	o	o	x	5.4	x	o	o	o	1.0
5024-0AC01	0.4	1.2	2000	o	x	o	x	4.8	o	x	o	o	2.0
5024-0AF01	0.4	1.45	3000	o	o	o	x	5.8	o	x	o	o	2.0
5024-0AH01	0.4	1.6	4500	o	x	x	o	6.6	x	o	o	o	1.0
5024-0AK01	0.4	1.8	6000	x	o	x	o	7.4	x	o	o	o	1.0
5032-0AC01	0.25	0.75	2000	x	x	x	x	3.6	o	o	x	o	4.0
5032-0AF01	0.25	0.95	3000	o	x	x	x	3.8	o	x	o	o	2.0
5032-0AH01	0.25	1.1	4500	x	x	o	x	4.6	o	x	o	o	2.0
5032-0AK01	0.25	1.2	6000	o	x	o	x	4.8	o	x	o	o	2.0
5034-0AC01	0.5	1.3	2000	x	o	o	x	5.4	o	o	x	o	4.0
5034-0AF01	0.5	1.7	3000	o	x	x	o	6.6	o	x	o	o	2.0
5034-0AH01	0.5	2.1	4500	o	o	x	o	8.0	o	x	o	o	2.0
5034-0AK01	0.5	2.4	6000	x	x	o	o	9.8	o	x	o	o	2.0
5036-0AC01	0.75	1.8	2000	x	o	x	o	7.4	o	o	x	o	4.0
5036-0AF01	0.75	2.4	3000	x	x	o	o	9.8	o	x	o	o	2.0
5036-0AH01	0.75	3.1	4500	o	x	o	o	10.8	o	x	o	o	2.0
5036-0AK01	0.75	3.6	6000	x	o	o	o	13.6	o	x	o	o	2.0

Table 3.3a

For continuation, see Table 3.3b

Servo motor				Current limit					Current controller				
1FT	M _o [Nm]	I _o [A]	n _{rated} [rev/min]	Contacts				I _{max} [A]	Contacts				Kp (l)
				2	3	4	5		6	7	8	9	
5042-0AC01	0.6	1.4	2000	o	o	o	x	5.8	x	o	x	o	4.5
5042-0AF01	0.6	1.9	3000	x	o	x	o	7.4	o	o	x	o	4.0
5042-0AH01	0.6	2.5	4500	x	x	o	o	9.8	o	x	o	o	2.0
5042-0AK01	0.6	3.0	6000	o	x	o	o	10.8	o	x	o	o	2.0
5044-0AC01	1.2	2.5	2000	x	x	o	o	9.8	o	o	x	o	4.0
5044-0AF01	1.2	3.5	3000	x	o	o	o	13.6	o	o	x	o	4.0
5044-0AH01	1.2	4.8	4500	o	o	o	o	16.0	o	x	o	o	2.0
5044-0AK01	1.2	5.7	6000	o	o	o	o	16.0	x	o	o	o	1.0
5045-0AH01	1.6	5.9	4500	o	o	o	o	16.0	o	x	o	o	2.0
5046-0AC01	2.0	3.3	2000	x	o	o	o	13.6	o	o	x	o	4.0
5046-0AF01	2.0	4.9	3000	o	o	o	o	16.0	o	x	o	o	2.0
5046-0AH01	2.0	6.7	4500	o	o	o	o	16.0	x	o	o	o	1.0
5046-0AK01	2.0	8.3	6000	o	o	o	o	16.0	o	o	o	o	0.5
5061-0AC01	1.2	3.3	2000	x	o	o	o	13.6	x	x	o	x	8.0
5061-0AF01	1.2	4.6	3000	o	o	o	o	16.0	x	o	x	o	4.5
5062-0AC01	2.2	3.5	2000	x	o	o	o	13.6	x	x	o	x	8.0
5062-0AF01	2.2	5.2	3000	o	o	o	o	16.0	o	o	x	o	4.0
5062-0AG01	2.2	6.5	4000	o	o	o	o	16.0	x	x	o	o	2.5
5062-0AK01	2.2	9.6	6000	o	o	o	o	16.0	x	o	o	o	1.0
5064-0AC01	4.5	7.2	2000	o	o	o	o	16.0	x	o	x	o	4.5
5064-0AF01	4.5	10.7	3000	o	o	o	o	16.0	o	x	o	o	2.0
5070-0AC01	3.0	6.3	2000	o	o	o	o	16.0	x	o	x	o	4.5

Table 3.3b

o ≙ Contact in initial position (OFF)

x ≙ Contact in ON position

Contacts S1.1, S2.1, S3.1: Reversal

Contact S1.10/resistor R200: Contact S1.10 in ON position/R200 provided in the form of a jumper:

The three axes are operated in current loop

Separately-ventilated motors can be used instead of the non-ventilated motors.

- 0A.01 ≙ non-ventilated motor
- 0S.01 ≙ separately-ventilated motor

3.1.2 Matching tables for motor/pulse-width-modulated inverter

Matching table for SIMODRIVE power modules **6SC6120-...** (20/40A)

Short designation A20, H20

Settings by means of switches S1, S2 and S3 on the adjustment module.

Servo motor				Current limit					Current controller				
1FT	M ₀ [Nm]	I ₀ [A]	n _{rated} [rev/min]	Contacts				I _{max} [A]	Contacts				Kp (l)
				2	3	4	5		6	7	8	9	
5034-0AH01	0.5	2.1	4500	x	x	x	x	9.2	0	x	0	0	2.0
5034-0AK01	0.5	2.4	6000	x	x	x	x	9.2	0	x	0	0	2.0
5036-0AF01	0.75	2.4	3000	x	x	x	x	9.2	0	x	0	0	2.0
5036-0AH01	0.75	3.1	4500	x	0	0	x	13.6	0	x	0	0	2.0
5036-0AK01	0.75	3.6	6000	0	0	0	x	14.4	0	x	0	0	2.0
5042-0AH01	0.6	2.5	4500	0	0	x	x	0.4	0	x	0	0	2.0
5042-0AK01	0.6	3.0	6000	0	x	0	x	12.0	0	x	0	0	2.0
5044-0AC01	1.2	2.5	2000	0	0	x	x	10.4	0	0	x	0	4.0
5044-0AF01	1.2	3.5	3000	0	0	0	x	14.4	0	0	x	0	4.0
5044-0AH01	1.2	4.8	4500	0	0	x	0	20.0	0	x	0	0	2.0
5044-0AK01	1.2	5.7	6000	x	x	0	0	24.4	0	x	0	0	2.0
5045-0AH01	1.6	5.9	4500	x	x	0	0	24.4	0	x	0	0	2.0
5046-0AC01	2.0	3.3	2000	x	0	0	x	13.6	0	0	x	0	4.0
5046-0AF01	2.0	4.9	3000	0	0	x	0	20.0	0	x	0	0	2.0
5046-0AH01	2.0	6.7	4500	0	x	0	0	27.2	0	x	0	0	2.0
5046-0AK01	2.0	8.3	6000	x	0	0	0	34.0	0	x	0	0	2.0

Table 3.4a

For continuation, see Table 3.4b

Servo motor				Current limit					Current controller				
1FT	M _o [Nm]	I _o [A]	n _{rated} [rev/min]	Contacts				I _{max} [A]	Contacts				Kp (l)
				2	3	4	5		6	7	8	9	
5061-0AC01	1.2	3.3	2000	x	o	o	x	13.6	x	x	o	x	8.0
5061-0AF01	1.2	4.6	3000	x	o	x	o	18.4	x	o	x	o	4.5
5062-0AC01	2.2	3.5	2000	o	o	o	x	14.4	x	x	o	x	8.0
5062-0AF01	2.2	5.2	3000	o	o	x	o	20.0	x	o	x	o	4.5
5062-0AG01	2.2	6.5	4000	o	x	o	o	27.2	o	o	x	o	4.0
5062-0AK01	2.2	9.6	6000	o	o	o	o	40.0	x	x	o	o	2.5
5064-0AC01	4.5	7.2	2000	o	x	o	o	27.2	x	x	o	x	8.0
5064-0AF01	4.5	10.7	3000	o	o	o	o	40.0	x	o	x	o	4.5
5064-0AG01	4.5	14.1	4000	o	o	o	o	40.0	x	x	o	o	2.5
5064-0AK01	4.5	21.4	6000	o	o	o	o	40.0	x	o	o	o	1.0
5066-0AC01	6.5	10.3	2000	o	o	o	o	40.0	x	x	o	x	8.0
5066-0AF01	6.5	16.3	3000	o	o	o	o	40.0	o	o	x	o	4.0
5066-0AG01	6.5	20.3	4000	o	o	o	o	40.0	o	x	o	o	2.0
5070-0AC01	3.0	6.3	2000	x	x	o	o	24.4	x	x	o	x	8.0
5070-0AF01	3.0	9.1	3000	x	o	o	o	34.0	x	o	x	o	4.5
5070-0AG01	3.0	12.5	4000	o	o	o	o	40.0	x	x	o	o	2.5
5070-0AK01	3.0	18.8	6000	o	o	o	o	40.0	x	o	o	o	1.0
5071-0AC01	4.5	9.0	2000	x	o	o	o	34.0	x	x	o	x	8.0
5071-0AF01	4.5	12.9	3000	o	o	o	o	40.0	o	o	x	o	4.0
5071-0AG01	4.5	18.0	4000	o	o	o	o	40.0	o	x	o	o	2.0
5072-0AC01	10.0	15.6	2000	o	o	o	o	40.0	x	x	o	x	8.0
5073-0AC01	7.0	13.5	2000	o	o	o	o	40.0	x	o	x	o	4.5
5073-0AF01	7.0	18.9	3000	o	o	o	o	40.0	o	x	o	o	2.0

Table 3.4b

o ≙ Contact in initial position (OFF)

x ≙ Contact in ON position

Contacts S1.1, S2.1, S3.1: Reversal

Contact S1.10/resistor R200: Contact S1.10 in ON position/R200 provided in the form of a jumper:

The three axes are operated in current loop

Separately-ventilated motors can be used instead of the non-ventilated motors.

- 0A.01 ≙ non-ventilated motor
- 0S.01 ≙ separately-ventilated motor

Matching table for SIMODRIVE power modules **6SC6130-...** (30/60A)

Short designation A30, H30

Settings by means of switches S1, S2 and S3 on the adjustment module.

Servo motor				Current limit					Current controller				
1FT	M _o [Nm]	I _o [A]	n _{rated} [rev/min]	Contacts				I _{max} [A]	Contacts				Kp (l)
				2	3	4	5		6	7	8	9	
5044-0AF01	1.2	3.5	3000	x	x	x	x	13.8	x	x	o	o	2.5
5044-0AH01	1.2	4.8	4500	o	x	o	x	18.0	o	x	o	o	2.0
5044-0AK01	1.2	5.7	6000	o	o	o	x	21.6	x	o	o	o	1.0
5045-0AH01	1.6	5.9	4500	x	x	x	o	23.4	o	x	o	o	2.0
5046-0AF01	2.0	4.9	3000	x	o	o	x	20.4	x	x	o	o	2.5
5046-0AH01	2.0	6.7	4500	x	o	x	o	27.6	o	x	o	o	2.0
5046-0AK01	2.0	8.3	6000	o	o	x	o	33.2	x	o	o	o	1.0
5061-0AC01	1.2	3.3	2000	x	x	x	x	13.8	x	x	o	x	8.0
5061-0AF01	1.2	4.6	3000	o	x	o	x	18.0	x	o	x	o	4.5
5062-0AC01	2.2	3.5	2000	x	x	x	x	13.8	x	x	o	x	8.0
5062-0AF01	2.2	5.2	3000	x	o	o	x	20.4	x	o	x	o	4.5
5062-0AG01	2.2	6.5	4000	o	o	x	o	30.0	o	o	x	o	4.0
5062-0AK01	2.2	9.6	6000	o	x	o	o	40.8	x	x	o	o	2.5
5064-0AC01	4.5	7.2	2000	x	o	x	o	27.6	x	x	o	x	8.0
5064-0AF01	4.5	10.7	3000	o	x	o	o	40.8	x	o	x	o	4.5
5064-0AG01	4.5	14.1	4000	o	o	o	o	60.0	o	o	x	o	4.0
5064-0AK01	4.5	21.4	6000	o	o	o	o	60.0	o	x	o	o	2.0
5066-0AC01	6.5	10.3	2000	o	x	o	o	40.8	x	x	o	x	8.0
5066-0AF01	6.5	16.3	3000	o	o	o	o	60.0	x	o	x	o	4.5
5066-0AG01	6.5	20.3	4000	o	o	o	o	60.0	x	x	o	o	2.5
5066-0AK01	6.5	31.0	6000	o	o	o	o	60.0	x	o	o	o	1.0
5070-0AC01	3.0	6.3	2000	o	x	x	o	24.6	x	x	o	x	8.0
5070-0AF01	3.0	9.1	3000	x	x	o	o	36.6	x	o	x	o	4.5
5070-0AG01	3.0	12.5	4000	x	o	o	o	51.0	o	o	x	o	4.0
5070-0AK01	3.0	18.8	6000	o	o	o	o	60.0	o	x	o	o	2.0

Table 3.5a

For continuation, see Table 3.5b

Servo motor				Current limit					Current controller				
1FT	M _o [Nm]	I _o [A]	n _{rated} [rev/min]	Contacts				I _{max} [A]	Contacts				Kp (l)
				2	3	4	5		6	7	8	9	
5071-0AC01	4.5	9.0	2000	x	x	o	o	36.6	x	x	o	x	8.0
5071-0AF01	4.5	12.9	3000	x	o	o	o	51.0	x	o	x	o	4.5
5071-0AG01	4.5	18.0	4000	o	o	o	o	60.0	x	x	o	o	2.5
5071-0AK01	4.5	26.5	6000	o	o	o	o	60.0	x	o	o	o	1.0
5072-0AC01	10.0	15.6	2000	o	o	o	o	60.0	o	x	x	x	11.0
5072-0AF01	10.0	22.7	3000	o	o	o	o	60.0	x	o	x	o	4.5
5072-0AG01	10.0	32.3	4000	o	o	o	o	60.0	x	x	o	o	2.5
5073-0AC01	7.0	13.5	2000	o	o	o	o	60.0	x	x	o	x	8.0
5073-0AF01	7.0	18.9	3000	o	o	o	o	60.0	o	o	x	o	4.0
5073-0AG01	7.0	25.0	4000	o	o	o	o	60.0	o	x	o	o	2.0
5074-0AC01	14.0	21.9	2000	o	o	o	o	60.0	x	o	x	o	4.5
5074-0AF01	14.0	31.8	3000	o	o	o	o	60.0	o	x	o	o	2.0
5076-0AC01	18.0	26.5	2000	o	o	o	o	60.0	x	o	x	o	4.5
5100-0AC01	10.0	18.5	2000	o	o	o	o	60.0	x	o	x	o	4.5
5100-0AF01	10.0	27.8	3000	o	o	o	o	60.0	x	x	o	o	2.5
5101-0AC01	15.0	30.8	2000	o	o	o	o	60.0	o	o	x	o	4.0
5102-0AA01	27.0	25.0	1200	o	o	o	o	60.0	o	x	x	x	11.0

Table 3.5b

o ≙ Contact in initial position (OFF)

x ≙ Contact in ON position

Contacts S1.1, S2.1, S3.1: Reversal

Contact S1.10/resistor R200: Contact S1.10 in ON position/R200 provided in the form of a jumper:

The three axes are operated in current loop

Separately-ventilated motors can be used instead of the non-ventilated motors.

- 0A.01 ≙ non-ventilated motor
- 0S.01 ≙ separately-ventilated motor

3.1.2 Matching tables for motor/pulse-width-modulated inverter

Matching table for SIMODRIVE power modules **6SC6140-...** (40/80A)

Short designation A40, H40

Settings by means of switches S1, S2 and S3 on the adjustment module.

Servo motor				Current limit					Current controller				
1FT	M ₀ [Nm]	I ₀ [A]	n _{rated} [rev/min]	Contacts				I _{max} [A]	Contacts				Kp (l)
				2	3	4	5		6	7	8	9	
5044-0AH01	1.2	4.8	4500	0	x	x	x	19.2	0	x	0	0	2.0
5044-0AK01	1.2	5.7	6000	x	x	0	x	23.2	0	x	0	0	2.0
5045-0AH01	1.6	5.9	4500	0	x	0	x	24.0	0	x	0	0	2.0
5046-0AF01	2.0	4.9	3000	0	x	x	x	19.2	x	x	0	0	2.5
5046-0AH01	2.0	6.7	4500	x	0	0	x	27.2	0	x	0	0	2.0
5046-0AK01	2.0	8.3	6000	0	x	x	0	32.8	x	0	0	0	1.0
5061-0AF01	1.2	4.6	3000	x	x	x	x	18.4	x	0	x	0	4.5
5062-0AF01	2.2	5.2	3000	0	0	x	x	20.8	x	0	x	0	4.5
5062-0AG01	2.2	6.5	4000	0	0	0	x	28.8	0	0	x	0	4.0
5062-0AK01	2.2	9.6	6000	0	0	x	0	40.0	x	x	0	0	2.5
5064-0AC01	4.5	7.2	2000	x	0	0	x	27.2	x	x	0	x	8.0
5064-0AF01	4.5	10.7	3000	0	0	x	0	40.0	x	0	x	0	4.5
5064-0AG01	4.5	14.1	4000	x	0	0	0	68.0	0	0	x	0	4.0
5064-0AK01	4.5	21.4	6000	0	0	0	0	80.0	x	x	0	0	2.5
5066-0AC01	6.5	10.3	2000	0	0	x	0	40.0	x	x	0	x	8.0
5066-0AF01	6.5	16.3	3000	x	0	0	0	68.0	x	0	x	0	4.5
5066-0AG01	6.5	20.3	4000	0	0	0	0	80.0	x	x	0	0	2.5
5066-0AK01	6.5	31.0	6000	0	0	0	0	80.0	x	0	0	0	1.0
5070-0AC01	3.0	6.3	2000	0	x	0	x	24.0	0	0	x	0	4.0
5070-0AF01	3.0	9.1	3000	x	0	x	0	36.8	0	x	0	0	2.0
5070-0AG01	3.0	12.5	4000	0	x	0	0	54.4	0	0	x	0	4.0
5070-0AK01	3.0	18.8	6000	0	0	0	0	80.0	x	x	0	0	2.5
5071-0AC01	4.5	9.0	2000	x	0	x	0	36.8	x	x	0	x	8.0
5071-0AF01	4.5	12.9	3000	x	x	0	0	48.8	x	0	x	0	4.5
5071-0AG01	4.5	18.0	4000	0	0	0	0	80.0	0	0	x	0	4.0
5071-0AK01	4.5	26.5	6000	0	0	0	0	80.0	0	x	0	0	2.0

Table 3.6a

For continuation, see Table 3.6b

3.1.2 Matching tables for motor/pulse-width-modulated inverter

Servo motor				Current limit					Current controller				
1FT	M _o [Nm]	I _o [A]	n _{rated} [rev/min]	Contacts				I _{max} [A]	Contacts				Kp (l)
				2	3	4	5		6	7	8	9	
5072-0AC01	10.0	15.6	2000	o	x	o	o	54.4	o	x	x	x	11.0
5072-0AF01	10.0	22.7	3000	o	o	o	o	80.0	x	x	o	x	8.0
5072-0AG01	10.0	32.3	4000	o	o	o	o	80.0	x	x	o	o	2.5
5073-0AC01	7.0	13.5	2000	o	x	o	o	54.4	x	x	o	x	8.0
5073-0AF01	7.0	18.9	3000	o	o	o	o	80.0	x	o	x	o	4.5
5073-0AG01	7.0	25.0	4000	o	o	o	o	80.0	x	x	o	o	2.5
5073-0AK01	7.0	38.9	6000	o	o	o	o	80.0	x	o	o	o	1.0
5074-0AC01	14.0	21.9	2000	o	o	o	o	80.0	x	x	o	x	8.0
5074-0AF01	14.0	31.8	3000	o	o	o	o	80.0	o	o	x	o	4.0
5076-0AC01	18.0	26.5	2000	o	o	o	o	80.0	x	o	x	o	4.5
5076-0AF01	18.0	40.0	3000	o	o	o	o	80.0	x	x	o	o	2.5
5100-0AC01	10.0	18.5	2000	o	o	o	o	80.0	x	x	o	x	8.0
5100-0AF01	10.0	27.8	3000	o	o	o	o	80.0	o	o	x	o	4.0
5100-0AG01	10.0	34.5	4000	o	o	o	o	80.0	o	x	o	o	2.0
5101-0AC01	15.0	26.8	2000	o	o	o	o	80.0	x	o	x	o	4.5
5101-0AF01	15.0	39.5	3000	o	o	o	o	80.0	x	x	o	o	2.5
5102-0AA01	27.0	25.0	1200	o	o	o	o	80.0	x	x	x	x	11.5
5102-0AC01	27.0	40.0	2000	o	o	o	o	80.0	x	o	x	o	4.5
5103-0AC01	19.0	33.9	2000	o	o	o	o	80.0	o	o	x	o	4.0
5104-0AA01	37.0	33.6	1200	o	o	o	o	80.0	o	x	x	x	11.0
5106-0AA01	45.0	40.9	1200	o	o	o	o	80.0	x	x	o	x	8.0

Table 3.6b

o ≙ Contact in initial position (OFF)

x ≙ Contact in ON position

Contacts S1.1, S2.1, S3.1: Reversal

Contact S1.10/resistor R200: Contact S1.10 in ON position/R200 provided in the form of a jumper:

The three axes are operated in current loop

Separately-ventilated motors can be used instead of the non-ventilated motors.

- 0A.01 ≙ non-ventilated motor
- 0S.01 ≙ separately-ventilated motor

Matching table for SIMODRIVE power modules **6SC6170-...** (70/140A)

Short designation A70, H70

Settings by means of switches S1, S2 and S3 on the adjustment module.

Servo motor				Current limit					Current controller				
1FT	M ₀ [Nm]	I ₀ [A]	n _{rated} [rev/min]	Contacts				I _{max} [A]	Contacts				K _p (l)
				2	3	4	5		6	7	8	9	
5046-0AK01	2.0	8.3	6000	0	x	x	x	33.6	x	0	0	0	1.0
5062-0AK01	2.2	9.6	6000	0	x	0	x	2.0	x	x	0	0	2.5
5064-0AF01	4.5	10.7	3000	0	x	0	x	42.0	x	0	x	0	4.5
5064-0AG01	4.5	14.1	4000	x	0	x	0	64.4	0	0	x	0	4.0
5064-0AK01	4.5	21.4	6000	0	x	0	0	95.2	x	x	0	0	2.5
5066-0AC01	6.5	10.3	2000	0	x	0	x	42.0	x	x	0	x	8.0
5066-0AF01	6.5	16.3	3000	0	0	x	0	70.0	x	0	x	0	4.5
5066-0AG01	6.5	20.3	4000	0	x	0	0	95.2	0	0	x	0	4.0
5066-0AK01	6.5	31.0	6000	0	0	0	0	140.0	x	x	0	0	2.5
5070-0AF01	3.0	9.1	3000	0	x	x	x	33.6	x	0	x	0	4.5
5070-0AG01	3.0	12.5	4000	0	x	x	0	57.4	0	0	x	0	4.0
5070-0AK01	3.0	18.8	6000	x	x	0	0	85.4	0	0	x	0	4.0
5071-0AC01	4.5	9.0	2000	0	0	x	x	36.4	x	x	0	x	8.0
5071-0AF01	4.5	12.9	3000	0	0	0	x	50.4	x	0	x	0	4.5
5071-0AG01	4.5	18.0	4000	x	x	0	0	85.4	0	0	x	0	4.0
5071-0AK01	4.5	26.5	6000	x	0	0	0	119.0	x	0	x	0	4.5
5072-0AC01	10.0	15.6	2000	0	x	x	0	57.4	0	x	x	x	11.0
5072-0AF01	10.0	22.7	3000	x	x	0	0	85.4	x	x	0	x	8.0
5072-0AG01	10.0	32.3	4000	0	0	0	0	140.0	0	x	x	0	5.5
5072-0AK01	10.0	50.0	6000	0	0	0	0	140.0	0	x	0	0	2.0
5073-0AC01	7.0	13.5	2000	x	x	x	0	54.6	x	x	0	x	8.0
5073-0AF01	7.0	18.9	3000	x	x	0	0	85.4	x	0	x	0	4.5
5073-0AG01	7.0	25.0	4000	x	0	0	0	119.0	x	0	x	0	4.5
5073-0AK01	7.0	38.9	6000	0	0	0	0	140.0	0	x	0	0	2.0
5074-0AC01	14.0	21.9	2000	x	x	0	0	85.4	x	x	0	x	8.0
5074-0AF01	14.0	31.8	3000	x	0	0	0	119.0	x	0	x	0	4.5
5074-0AG01	14.0	45.2	4000	0	0	0	0	140.0	x	x	0	0	2.5
5074-0AK01	14.0	66.7	6000	0	0	0	0	140.0	x	0	0	0	1.0
5076-0AC01	18.0	26.5	2000	x	0	0	0	119.0	x	x	0	x	8.0
5076-0AF01	18.0	40.0	3000	0	0	0	0	140.0	x	0	x	0	4.5
5076-0AG01	18.0	60.0	4000	0	0	0	0	140.0	0	x	0	0	2.0
5076-0AK01	18.0	85.7	6000	0	0	0	0	140.0	x	0	0	0	1.0

Table 3.7a

For continuation, see Table 3.7b

Servo motor				Current limit					Current controller				
1FT	M _o [Nm]	I _o [A]	n _{rated} [rev/min]	Contacts				I _{max} [A]	Contacts				K _p (l)
				2	3	4	5		6	7	8	9	
5100-0AC01	10.0	18.5	2000	x	x	o	o	85.4	x	x	o	x	8.0
5100-0AF01	10.0	27.8	3000	o	o	o	o	140.0	x	o	x	o	4.5
5100-0AG01	10.0	34.5	4000	o	o	o	o	140.0	x	x	o	o	2.5
5100-0AK01	10.0	50.0	6000	o	o	o	o	140.0	x	o	o	o	1.0
5101-0AC01	15.0	26.8	2000	x	o	o	o	119.0	x	x	o	x	8.0
5101-0AF01	15.0	39.5	3000	o	o	o	o	140.0	o	o	x	o	4.0
5101-0AG01	15.0	51.7	4000	o	o	o	o	140.0	o	x	o	o	2.0
5101-0AK01	15.0	75.0	6000	o	o	o	o	140.0	x	o	o	o	1.0
5102-0AA01	27.0	25.0	1200	o	x	o	o	95.2	x	x	x	x	11.5
5102-0AC01	27.0	40.0	2000	o	o	o	o	140.0	o	x	x	x	11.0
5102-0AF01	27.0	60.0	3000	o	o	o	o	140.0	x	o	x	o	4.5
5103-0AC01	19.0	33.9	2000	o	o	o	o	140.0	x	o	x	o	4.5
5103-0AF01	19.0	51.4	3000	o	o	o	o	140.0	o	x	o	o	2.0
5103-0AG01	19.0	61.3	4000	o	o	o	o	140.0	o	x	o	o	2.0
5104-0AA01	37.0	33.6	1200	o	o	o	o	140.0	x	x	x	x	11.5
5104-0AC01	37.0	55.2	2000	o	o	o	o	140.0	x	x	o	x	8.0
5106-0AA01	45.0	40.9	1200	o	o	o	o	140.0	x	x	x	x	11.5
5106-0AC01	45.0	67.2	2000	o	o	o	o	140.0	x	o	x	o	4.5
5108-0AA01	55.0	50.0	1200	o	o	o	o	140.0	x	x	x	x	11.5
5132-0AA01	60.0	55.0	1200	o	o	o	o	140.0	o	x	x	o	5.5
5134-0AA01	75.0	68.0	1200	o	o	o	o	140.0	x	o	x	o	4.5

Table 3.7b

o ≙ Contact in initial position (OFF)

x ≙ Contact in ON position

Contacts S1.1, S2.1, S3.1: Reversal

Contact S1.10/resistor R200: Contact S1.10 in ON position/R200 provided in the form of a jumper:

The three axes are operated in current loop

Separately-ventilated motors can be used instead of the non-ventilated motors.

- 0A.01 ≙ non-ventilated motor
- 0S.01 ≙ separately-ventilated motor

3.1.2 Matching tables for motor/pulse-width-modulated inverter

Matching table for SIMODRIVE power modules **6SC6190-...** **(90/180A)**

Short designation A90, H90

Settings by means of switches S1, S2 and S3 on the adjustment module.

Servo motor				Current limit					Current controller				
1FT	M _o [Nm]	I _o [A]	n _{rated} [rev/min]	Contacts				I _{max} [A]	Contacts				K _p (l)
				2	3	4	5		6	7	8	9	
5064-0AF01	4.5	10.7	3000	x	x	x	x	41.4	x	o	x	o	4.5
5064-0AG01	4.5	14.1	4000	o	x	o	x	54.0	o	o	x	o	4.0
5064-0AK01	4.5	21.4	6000	x	o	x	o	82.8	x	x	o	o	2.5
5066-0AC01	6.5	10.3	2000	o	x	x	x	43.2	x	o	x	o	4.5
5066-0AF01	6.5	16.3	3000	x	x	x	o	70.2	x	o	x	o	4.5
5066-0AG01	6.5	20.3	4000	x	o	x	o	82.8	o	o	x	o	4.0
5066-0AK01	6.5	31.0	6000	o	x	o	o	122.4	o	x	o	o	2.0
5070-0AG01	3.0	12.5	4000	x	x	o	x	52.2	o	o	x	o	4.0
5070-0AK01	3.0	18.8	6000	o	x	x	o	73.8	x	x	o	o	2.5
5071-0AF01	4.5	12.9	3000	x	x	o	x	52.5	x	o	x	o	4.5
5071-0AG01	4.5	18.0	4000	o	x	x	o	73.8	o	o	x	o	4.0
5071-0AK01	4.5	26.5	6000	x	x	o	o	109.8	x	x	o	o	2.5
5072-0AC01	10.0	15.6	2000	o	x	o	x	54.0	x	x	o	x	8.0
5072-0AF01	10.0	22.7	3000	x	o	x	o	82.8	x	x	o	x	8.0
5072-0AG01	10.0	32.3	4000	o	x	o	o	122.4	o	x	x	o	5.5
5072-0AK01	10.0	50.0	6000	o	o	o	o	180.0	x	x	o	o	2.5
5073-0AC01	7.0	13.5	2000	o	x	o	x	54.0	x	x	o	x	8.0
5073-0AF01	7.0	18.9	3000	x	o	x	o	82.8	x	o	x	o	4.5
5073-0AG01	7.0	25.0	4000	x	x	o	o	109.8	x	o	x	o	4.5
5073-0AK01	7.0	38.9	6000	o	o	o	o	180.0	x	x	o	o	2.5
5074-0AC01	14.0	21.9	2000	x	o	x	o	82.8	x	x	o	x	8.0
5074-0AF01	14.0	31.8	3000	o	x	o	o	122.4	x	o	x	o	4.5
5074-0AG01	14.0	45.2	4000	o	o	o	o	180.0	o	o	x	o	4.0
5074-0AK01	14.0	66.7	6000	o	o	o	o	180.0	x	o	o	o	1.0
5076-0AC01	18.0	26.5	2000	x	x	o	o	109.8	x	x	o	x	8.0
5076-0AF01	18.0	40.0	3000	o	o	o	o	180.0	x	o	x	o	4.5
5076-0AG01	18.0	60.0	4000	o	o	o	o	180.0	x	x	o	o	2.5
5076-0AK01	18.0	85.7	6000	o	o	o	o	180.0	x	o	o	o	1.0
5100-0AC01	10.0	18.5	2000	o	o	x	o	90.0	x	x	o	x	8.0
5100-0AF01	10.0	27.8	3000	o	x	o	o	122.4	x	o	x	o	4.5
5100-0AG01	10.0	34.5	4000	o	o	o	o	180.0	o	o	x	o	4.0
5100-0AK01	10.0	50.0	6000	o	o	o	o	180.0	o	x	o	o	2.0

Table 3.8a

For continuation, see Table 3.8b

Servo motor				Current limit					Current controller				
1FT	M _o [Nm]	I _o [A]	n _{rated} [rev/min]	Contacts				I _{max} [A]	Contacts				Kp (l)
				2	3	4	5		6	7	8	9	
5101-0AC01	15.0	26.8	2000	o	x	o	o	122.4	x	x	o	x	8.0
5101-0AF01	15.0	39.5	3000	o	o	o	o	180.0	x	o	x	o	4.5
5101-0AG01	15.0	51.7	4000	o	o	o	o	180.0	x	x	o	o	2.5
5101-0AK01	15.0	75.0	6000	o	o	o	o	180.0	x	o	o	o	1.0
5102-0AA01	27.0	25.0	1200	o	o	x	o	90.0	x	x	x	x	11.5
5102-0AC01	27.0	40.0	2000	x	o	o	o	153.0	x	x	x	x	11.5
5102-0AF01	27.0	60.0	3000	o	o	o	o	180.0	x	o	x	o	4.5
5102-0AG01	27.0	79.4	4000	o	o	o	o	180.0	o	x	o	o	2.0
5103-0AC01	19.0	33.9	2000	x	o	o	o	153.0	x	x	o	x	8.0
5103-0AF01	19.0	51.4	3000	o	o	o	o	180.0	o	o	x	o	4.0
5103-0AG01	19.0	61.3	4000	o	o	o	o	180.0	o	x	o	o	2.0
5104-0AA01	37.0	33.6	1200	x	o	o	o	153.0	x	x	x	x	11.5
5104-0AC01	37.0	55.2	2000	o	o	o	o	180.0	x	x	o	x	8.0
5104-0AF01	37.0	84.0	3000	o	o	o	o	180.0	x	x	o	o	2.5
5106-0AA01	45.0	40.9	1200	x	o	o	o	153.0	x	x	x	x	11.5
5106-0AC01	45.0	67.2	2000	o	o	o	o	180.0	x	x	o	x	8.0
5108-0AA01	55.0	50.0	1200	o	o	o	o	180.0	x	x	x	x	11.5
5108-0AC01	55.0	82.1	2000	o	o	o	o	180.0	x	x	o	x	8.0
5132-0AA01	60.0	55.0	1200	o	o	o	o	180.0	x	o	o	x	6.5
5132-0AC01	60.0	86.0	2000	o	o	o	o	180.0	x	x	o	o	2.5
5134-0AA01	75.0	68.0	1200	o	o	o	o	180.0	o	x	x	o	5.5
5136-0AA01	85.0	78.0	1200	o	o	o	o	180.0	x	o	x	o	4.5
5138-0AA01	105.0	96.0	1200	o	o	o	o	180.0	o	o	x	o	4.0

Table 3.8b

o ≙ Contact in initial position (OFF)

x ≙ Contact in ON position

Contacts S1.1, S2.1, S3.1: Reversal

Contact S1.10/resistor R200: Contact S1.10 in ON position/R200 provided in the form of a jumper:

The three axes are operated in current loop

Separately-ventilated motors can be used instead of the non-ventilated motors.

- 0A.01 ≙ non-ventilated motor
- 0S.01 ≙ separately-ventilated motor

Matching table for SIMODRIVE power modules **6SC6190-...** (120/240 A)

Short designation A92, H92

Setting by means of switches S1, S2 and S3 on the adjustment module.

Servo motor				Current limit					Current controller				
1FT	M _o [Nm]	I _o [A]	n _{rated} [rev/min]	Contacts				I _{max} [A]	Contacts				Kp (l)
				2	3	4	5		6	7	8	9	
5064-0AK01	4.5	21.4	6000	0	0	0	x	86.0	x	x	0	0	2.5
5066-0AF01	6.5	16.3	3000	0	0	x	x	62.0	x	0	x	0	4.5
5066-0AG01	6.5	20.3	4000	x	0	0	x	82.0	0	0	x	0	4.0
5066-0AK01	6.5	31.0	6000	0	0	x	0	120.0	0	x	0	0	2.0
5070-0AK01	3.0	18.8	6000	0	x	0	x	72.0	x	x	0	0	2.5
5071-0AG01	4.5	18.0	4000	0	x	0	x	72.0	0	0	x	0	4.0
5071-0AK01	4.5	26.5	6000	x	0	x	0	110.0	x	x	0	0	2.5
5072-0AC01	10.0	15.6	2000	0	0	x	x	62.0	x	x	x	x	11.5
5072-0AF01	10.0	22.7	3000	0	0	0	x	86.0	0	x	0	x	7.5
5072-0AG01	10.0	32.3	4000	0	0	x	0	120.0	0	x	x	0	5.5
5072-0AK01	10.0	50.0	6000	x	0	0	0	204.0	x	x	0	0	2.5
5073-0AF01	7.0	18.9	3000	0	x	0	x	72.0	x	0	x	0	4.5
5073-0AG01	7.0	25.0	4000	0	x	x	0	98.0	0	0	x	0	4.0
5073-0AK01	7.0	38.9	6000	x	x	0	0	146.0	x	x	0	0	2.5
5074-0AC01	14.0	21.9	2000	0	0	0	x	86.0	x	x	x	x	11.5
5074-0AF01	14.0	31.8	3000	0	0	x	0	120.0	0	0	0	x	6.0
5074-0AG01	14.0	45.2	4000	0	x	0	0	163.0	0	0	x	0	4.0
5074-0AK01	14.0	66.7	6000	0	0	0	0	240.0	x	x	0	0	2.5
5076-0AC01	18.0	26.5	2000	x	0	x	0	110.0	x	x	0	x	8.0
5076-0AF01	18.0	40.0	3000	0	x	0	0	163.0	x	0	0	x	6.5
5076-0AG01	18.0	60.0	4000	0	0	0	0	240.0	x	0	x	0	4.5
5076-0AK01	18.0	85.7	6000	0	0	0	0	240.0	0	x	0	0	2.0
5100-0AC01	10.0	18.5	2000	0	x	0	x	72.0	x	0	0	x	6.5
5100-0AF01	10.0	27.8	3000	x	0	x	0	110.0	x	0	x	0	4.5
5100-0AG01	10.0	34.5	4000	x	x	0	0	146.0	x	x	0	0	2.5
5100-0AK01	10.0	50.0	6000	x	0	0	0	204.0	0	x	0	0	2.0

Table 3.9a

For continuation, see Table 3.9b

Servo motor				Current limit					Current controller				
1FT	M _o [Nm]	I _o [A]	n _{rated} [rev/min]	Contacts				I _{max} [A]	Contacts				Kp (l)
				2	3	4	5		6	7	8	9	
5101-0AC01	15.0	26.8	2000	x	o	x	o	110.0	x	o	o	x	6.5
5101-0AF01	15.0	39.5	3000	o	x	o	o	163.0	x	o	x	o	4.5
5101-0AG01	15.0	51.7	4000	x	o	o	o	204.0	x	x	o	o	2.5
5101-0AK01	15.0	75.0	6000	o	o	o	o	240.0	o	x	o	o	2.0
5102-0AA01	27.0	25.0	1200	o	x	x	o	98.0	x	x	x	x	11.5
5102-0AC01	27.0	40.0	2000	o	x	o	o	163.0	x	x	o	x	8.0
5102-0AF01	27.0	60.0	3000	o	o	o	o	240.0	o	o	o	x	6.0
5102-0AG01	27.0	79.4	4000	o	o	o	o	240.0	x	x	o	o	2.5
5103-0AC01	19.0	33.9	2000	x	x	o	o	146.0	o	x	o	x	7.5
5103-0AF01	19.0	51.4	3000	x	o	o	o	204.0	x	o	x	o	4.5
5103-0AG01	19.0	61.3	4000	o	o	o	o	240.0	x	x	o	o	2.5
5104-0AA01	37.0	33.6	1200	x	x	o	o	146.0	x	x	x	x	11.5
5104-0AC01	37.0	55.2	2000	x	o	o	o	204.0	x	x	x	x	11.5
5104-0AF01	37.0	84.0	3000	o	o	o	o	240.0	o	o	x	o	4.0
5106-0AA01	45.0	40.9	1200	o	x	o	o	163.0	x	x	x	x	11.5
5106-0AC01	45.0	67.2	2000	o	o	o	o	240.0	o	o	x	x	9.5
5106-0AF01	45.0	93.8	3000	o	o	o	o	240.0	o	o	x	o	4.0
5108-0AA01	55.0	50.0	1200	x	o	o	o	204.0	x	x	x	x	11.5
5108-0AC01	55.0	82.1	2000	o	o	o	o	240.0	o	o	o	x	6.0
5132-0AA01	60.0	55.0	1200	x	o	o	o	204.0	o	o	x	x	9.5
5132-0AC01	60.0	86.0	2000	o	o	o	o	240.0	x	o	x	o	4.5
5134-0AA01	75.0	68.0	1200	o	o	o	o	240.0	o	o	x	x	9.5
5134-0AC01	75.0	107.0	2000	o	o	o	o	240.0	o	o	x	o	4.0
5136-0AA01	85.0	78.0	1200	o	o	o	o	240.0	x	x	o	x	8.0
5138-0AA01	105.0	96.0	1200	o	o	o	o	240.0	o	o	o	x	6.0

Table 3.9b

o ≙ Contact in initial position (OFF)

x ≙ Contact in ON position

Contacts S1.1, S2.1, S3.1: Reversal

Contact S1.10/resistor R200: Contact S1.10 in ON position/R200 provided in the form of a jumper:

The three axes are operated in current loop

Separately-ventilated motors can be used instead of the non-ventilated motors.

- 0A.01 ≙ non-ventilated motor
- 0S.01 ≙ separately-ventilated motor

Matching table for SIMODRIVE power modules **6SC6190-...** (200/400 A)

Short designation A99

Setting by means of switches S1, S2 and S3 on the adjustment module.

Servo motor				Current limit					Current controller				
1FT	M _o [Nm]	I _o [A]	n _{rated} [rev/min]	Contacts				I _{max} [A]	Contacts				Kp (l)
				2	3	4	5		6	7	8	9	
5064-0AK01	4,5	21,4	6000	x	x	x	x	92,0	x	x	o	o	2,5
5066-0AG01	6,5	20,3	4000	x	x	x	x	92,0	o	o	x	o	4,0
5066-0AK01	6,5	31,0	6000	o	x	o	x	120,0	o	x	o	o	2,0
5072-0AF01	10,0	22,7	3000	x	x	x	x	92,0	x	x	o	x	8,0
5072-0AG01	10,0	32,3	4000	o	x	o	x	120,0	o	x	x	o	5,5
5072-0AK01	10,0	50,0	6000	x	o	x	o	184,0	x	x	o	o	2,5
5074-0AC01	14,0	21,9	2000	x	x	x	x	92,0	o	x	x	x	11,0
5074-0AF01	14,0	31,8	3000	x	o	o	x	136,0	o	o	o	x	6,0
5074-0AG01	14,0	45,2	4000	x	o	x	o	184,0	o	o	x	o	4,0
5074-0AK01	14,0	66,7	6000	o	x	o	o	272,0	x	x	o	o	2,5
5076-0AC01	18,0	26,5	2000	o	o	x	x	104,0	o	x	o	x	7,5
5076-0AF01	18,0	40,0	3000	x	x	x	o	156,0	x	o	o	x	6,5
5076-0AG01	18,0	60,0	4000	x	x	o	o	244,0	o	o	x	o	4,0
5076-0AK01	18,0	85,7	6000	x	o	o	o	340,0	x	x	o	o	2,5
5102-0AA01	27,0	25,0	1200	o	x	x	x	96,0	x	x	x	x	11,5
5102-0AC01	27,0	40,0	2000	o	x	x	o	164,0	x	x	o	x	8,0
5102-0AF01	27,0	60,0	3000	x	x	o	o	244,0	o	o	x	x	5,5
5102-0AG01	27,0	79,4	4000	o	x	o	o	272,0	x	x	o	o	2,5
5104-0AA01	37,0	33,6	1200	x	o	o	x	136,0	x	x	x	x	11,5
5104-0AC01	37,0	55,2	2000	o	o	x	o	200,0	o	o	x	x	9,5
5106-0AA01	45,0	40,9	1200	o	x	x	o	164,0	x	x	x	x	11,5
5106-0AC01	45,0	67,2	2000	o	x	o	o	272,0	o	o	x	x	9,5

Table 3.10a

For continuation, see Table 3.10b

Servo motor				Current limit					Current controller				
1FT	M _o [Nm]	I _o [A]	n _{rated} [rev/mi]	Contacts				I _{max} [A]	Contacts				Kp (l)
				2	3	4	5		6	7	8	9	
5108-0AA01	55,0	50,0	1200	o	o	x	o	200,0	x	x	x	x	11,5
5108-0AC01	55,0	82,1	2000	x	o	o	o	340,0	x	x	o	x	8,0
5132-0AA01	60,0	55,0	1200	o	o	x	o	200,0	o	o	x	x	9,5
5132-0AC01	60,0	86,0	2000	x	o	o	o	340,0	o	o	o	x	6,0
5134-0AA01	75,0	68,0	1200	o	x	o	o	272,0	o	o	x	x	9,5
5134-0AC01	75,0	107,0	1200	o	o	o	o	400,0	o	x	x	o	5,5
5136-0AA01	85,0	78,0	6000	x	o	o	o	340,0	o	x	x	x	11,0
5138-0AA01	105,0	96,0	4000	o	o	o	o	400,0	o	o	x	x	9,5
5071-0AU01	4,5	26,5	6000	o	o	x	x	104,0	x	x	o	o	2,5
5073-0AG01	7,0	25,0	4000	o	o	x	x	104,0	o	o	x	o	4,0
5073-0AU01	7,0	38,9	6000	o	x	x	o	164,0	x	x	o	o	2,5
5100-0AF01	10,0	27,8	3000	x	x	o	x	116,0	x	o	x	o	4,5
5100-0AG01	10,0	34,5	4000	o	o	o	x	144,0	x	x	o	o	2,5
5100-0AK01	10,0	50,0	6000	o	o	x	o	200,0	o	x	o	o	2,0
5101-0AC01	15,0	26,8	2000	x	x	o	x	116,0	x	o	o	x	6,5
5101-0AF01	15,0	39,5	3000	o	x	x	o	164,0	o	x	x	o	5,5
5101-0AG01	15,0	51,7	4000	o	o	x	o	200,0	x	x	o	o	2,5
5101-0AK01	15,0	75,0	6000	o	x	o	o	272,0	o	x	o	o	2,0
5103-0AC01	19,0	33,9	2000	o	o	o	x	144,0	x	o	o	x	6,5
5103-0AF01	19,0	51,4	3000	o	o	x	o	200,0	o	o	x	o	4,0
5103-0AG01	19,0	61,3	4000	o	x	o	o	272,0	x	x	o	o	2,5
5102-0SZ01	34,0	113,0	5000	o	o	o	o	400,0	o	x	x	o	5,5
5102-0SK01	34,0	130,0	6000	o	o	o	o	400,0	o	o	x	o	4,0
5102-0SG01	34,0	100,0	4000	o	o	o	o	400,0	x	x	o	o	2,5

Table 3.10b

o ≙ Contact in initial position (OFF)

x ≙ Contact in ON position

Contacts S1.1, S2.1, S3.1: Reversal

Contact S1.10/resistor R200: Contact S1.10 in ON position/R200 provided in the form of a jumper:

The three axes are operated in current loop

Separately-ventilated motors can be used instead of the non-ventilated motors.

- 0A.01 ≙ non-ventilated motor
- 0S.01 ≙ separately-ventilated motor

3.1.3 Current setpoint limitation, "Hold against mechanical stop" function

3.1.3 Current setpoint limitation, "Hold against mechanical stop" function

When voltage is supplied to terminal 96 (Figs. 3.2 and 3.3.), the "speed controller at maximum" monitoring circuit is made inoperative.

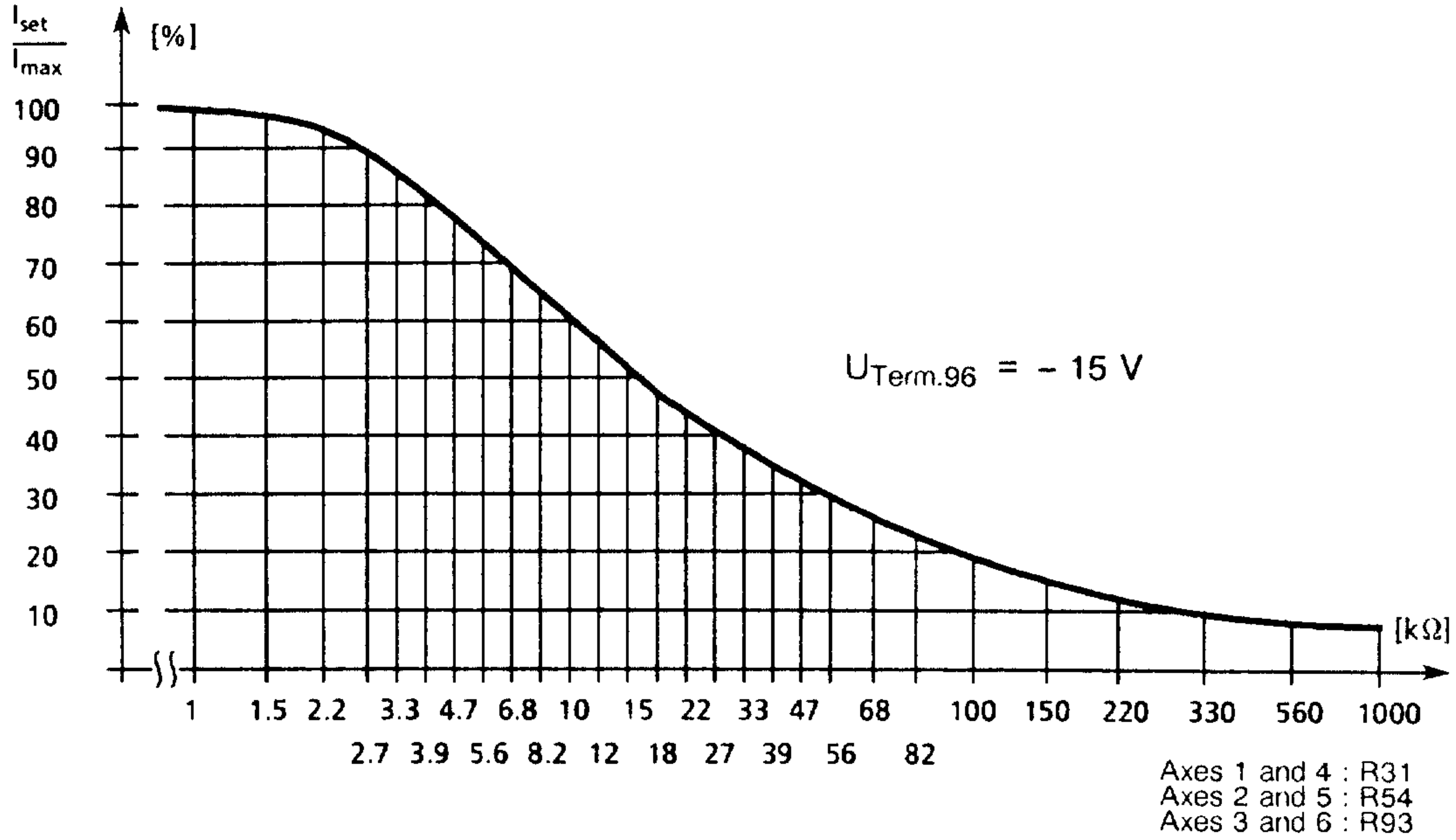

Fig. 3.2 Current setpoint limitation as a function of R31, R54, R93 on the adjustment module

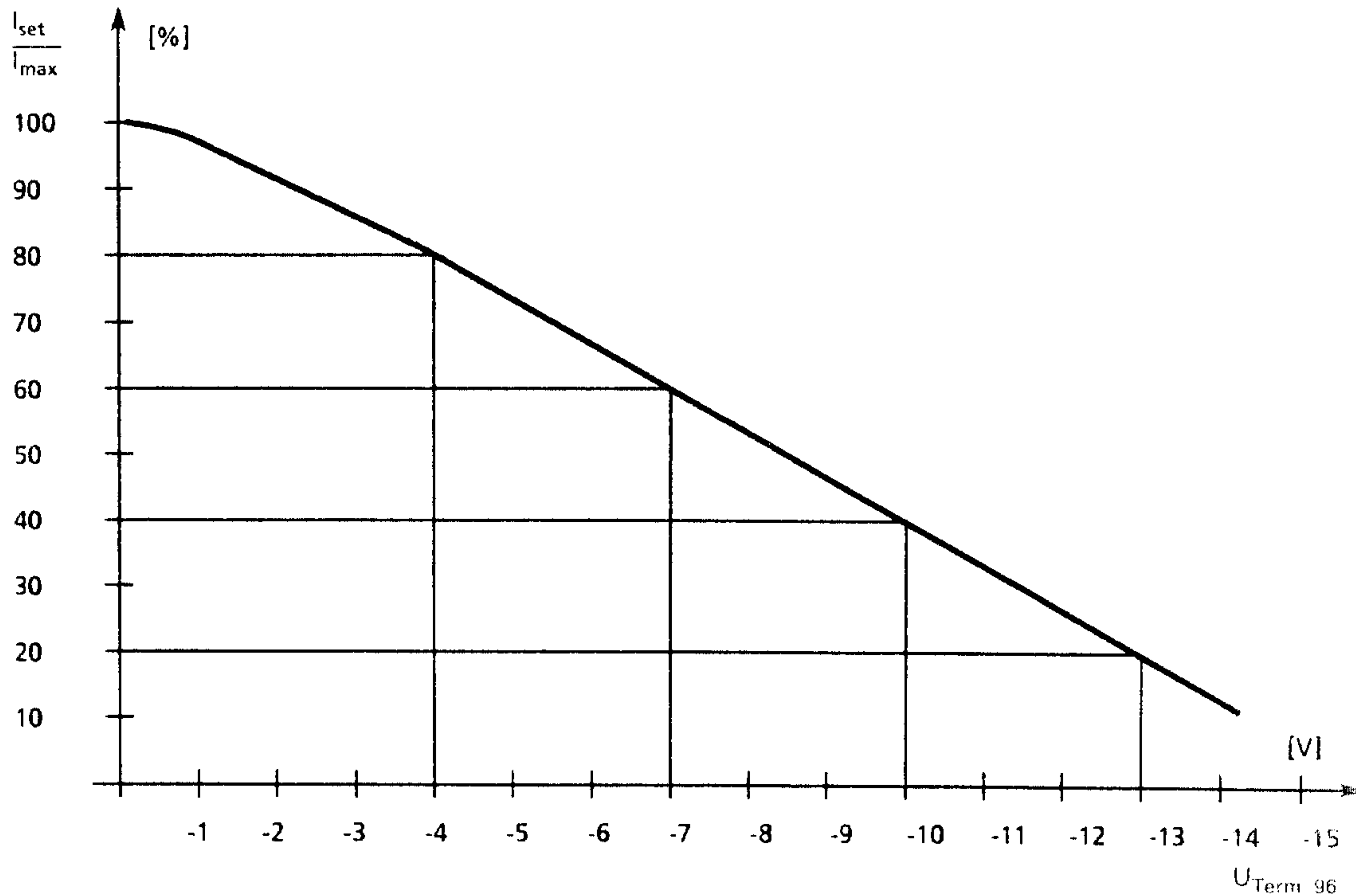

Fig. 3.3 Current setpoint limitation as a function of the voltage applied at terminal 96
(The input resistance of terminal 96 amounts to 12 kΩ)

3.1.4 Speed controller adaptation

The nominal reset time T_{Nrated} of the speed controller can be set by means of potentiometers R135 (axes 1 and 4), R235 (axes 2 and 5) and R335 (axes 3 and 6). If the reset time T_N of the speed controller must be reduced adaptively at lowest speeds, the adjustment module must be fitted with resistor R15 (axes 1 and 4), R46 (axes 2 and 5) and R77 (axes 3 and 6). The reset time can be reduced to T_{Nadapt} with the following resistance values:

With 0.1 k Ω to 5 % of T_{Nrated}
 With 1.2 k Ω to 25 % of T_{Nrated}
 With 1.8 k Ω to 33 % of T_{Nrated}
 With 3.9 k Ω to 50 % of T_{Nrated}

With 10 k Ω to 72 % of T_{Nrated}
 With 20 k Ω to 84 % of T_{Nrated}
 With 39 k Ω to 91 % of T_{Nrated}

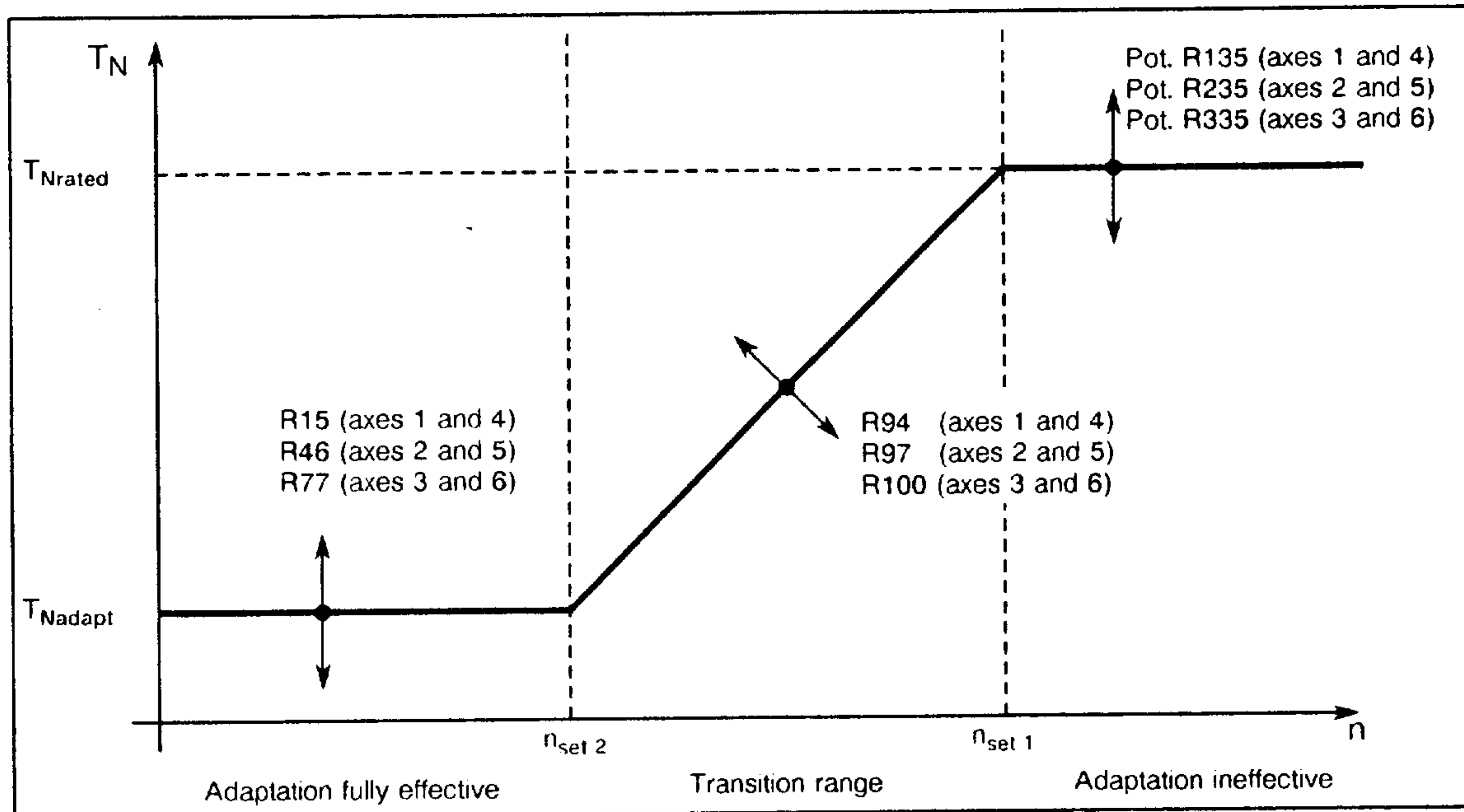

Fig. 3.4 Relationship between reset time and speed

With the speed controller module as supplied, i.e. no resistors fitted in positions R94 (axes 1 and 4), R97 (axes 2 and 5) and R100 (axes 3 and 6), the reduction of the reset time begins at $n_{set 1} \hat{=} \text{approx. } 200 \text{ mV}$ and the preset minimum is reached at $n_{set 2} \hat{=} \text{approx. } 33 \text{ mV}$.

The point at which the reset time adaptation becomes effective can be adjusted with resistors R94, R97 and R100 as indicated in the following table (values apply to versions from K onwards).

R in k Ω	$n_{set 1}$ in mV	$n_{set 2}$ in mV
0.1	20	4
1.0	50	10
1.5	60	12
2.2	80	15
4.7	110	20
10.0	140	30
open	200	33

Table 3.10

3.1.5 Reversal

The direction of rotation of the motor can be reversed by contact 1 of DIL switches S1 (axes 1 and 4), S2 (axes 2 and 5) and S3 (axes 3 and 6) on the adjustment module.

3.1.6 Electrical weight compensation

Resistors R3, R5 (axes 1 and 4), R32, R36 (axes 2 and 5) and R63, R67 (axes 3 and 6) are soldered into the adjustment module in order to achieve weight compensation with mechanically preloaded axes. When setting the resistance values, note that $I_{\text{weight compensation}}$ must not be allowed to exceed I_{rated} . At the same time, the internal current limit ($I_{\text{max}}/I_{\text{lim}}$) at switch S2 (contacts 2 to 5) must be reduced by the same percentage.

Example: Precondition: $I_{\text{max}}/I_{\text{lim}} = 100\%$ (S2.2 bis S2.5 to OFF)
 Required: $I_{\text{weight comp.}}/I_{\text{max}} = 30\%$
 → Correction: $I_{\text{max}}/I_{\text{lim}} = 100\% - 30\% \approx 68\%$ (S2.3 to ON)

If this is not done, monitors may operate in the power section.

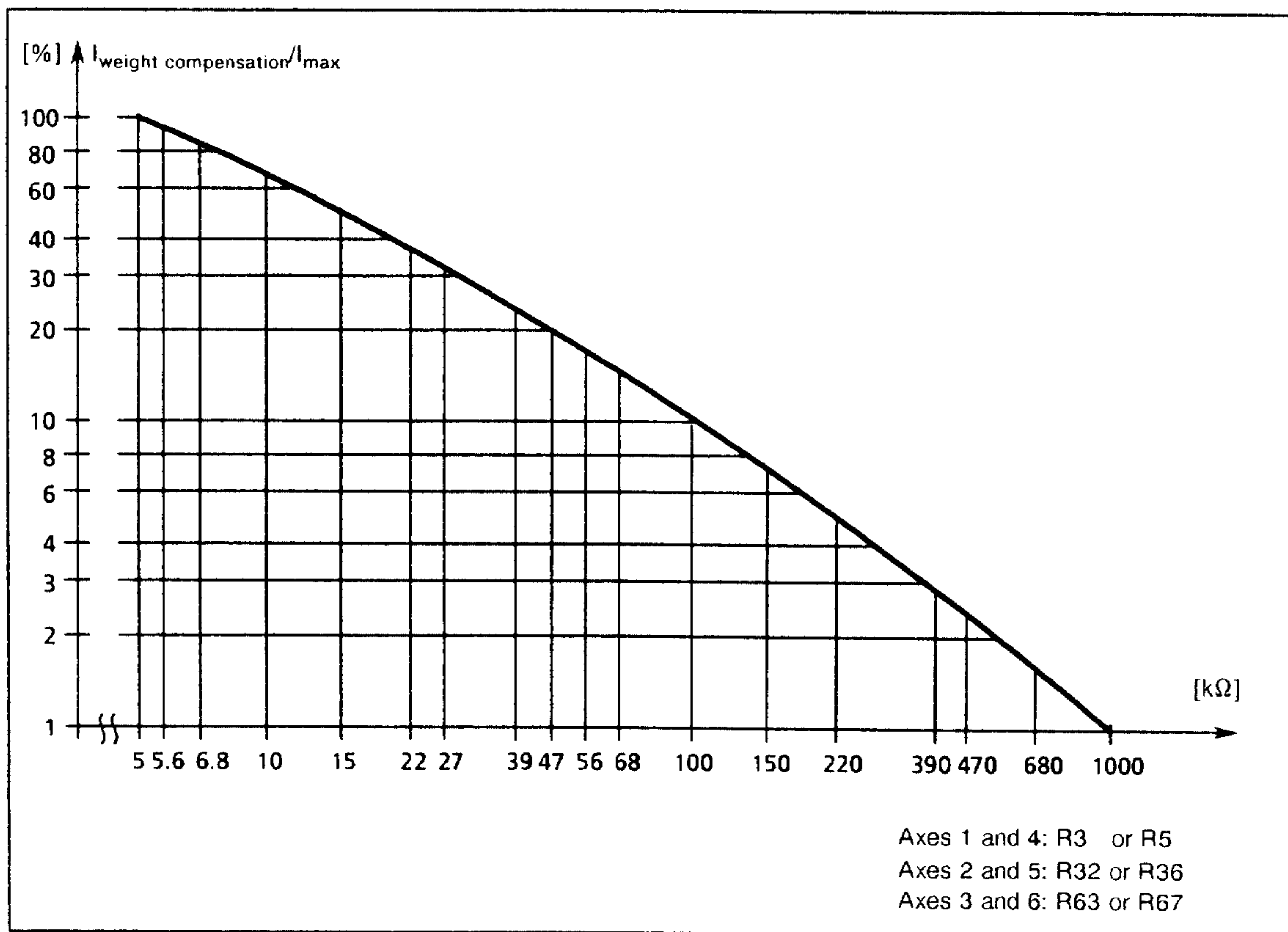

Fig. 3.5 Supplementary current setpoint for electrical weight compensation

A positive current setpoint on test sockets T1 (axes 1 and 4), T2 (axes 2 and 5), T3 (axes 3 and 6) indicates that resistors R5, R36 and R67 have been fitted in the adjustment module. A negative current setpoint is obtained by fitting resistors R3, R32 and R63 in the adjustment module.

3.1.7 Current-controlled operation

Apply the current setpoint (I_{set}) to the following terminals:

- X411:58 and X411:8 (axes 1 and 4)
- X421:58 and X421:8 (axes 2 and 5)
- X431:58 and X431:8 (axes 3 and 6)

Then implement the central pulse and controller enabling (connect terminal X121:63 and X121:64 to terminal X121:9 on the power supply).

The procedure subsequently adopted depends on the type of adjustment module and whether the current of the 3 (6) axes is to be controlled in common or individually.

Operate all 3 (6) axes on current control (with P component only)

a) 9-pole switch S1

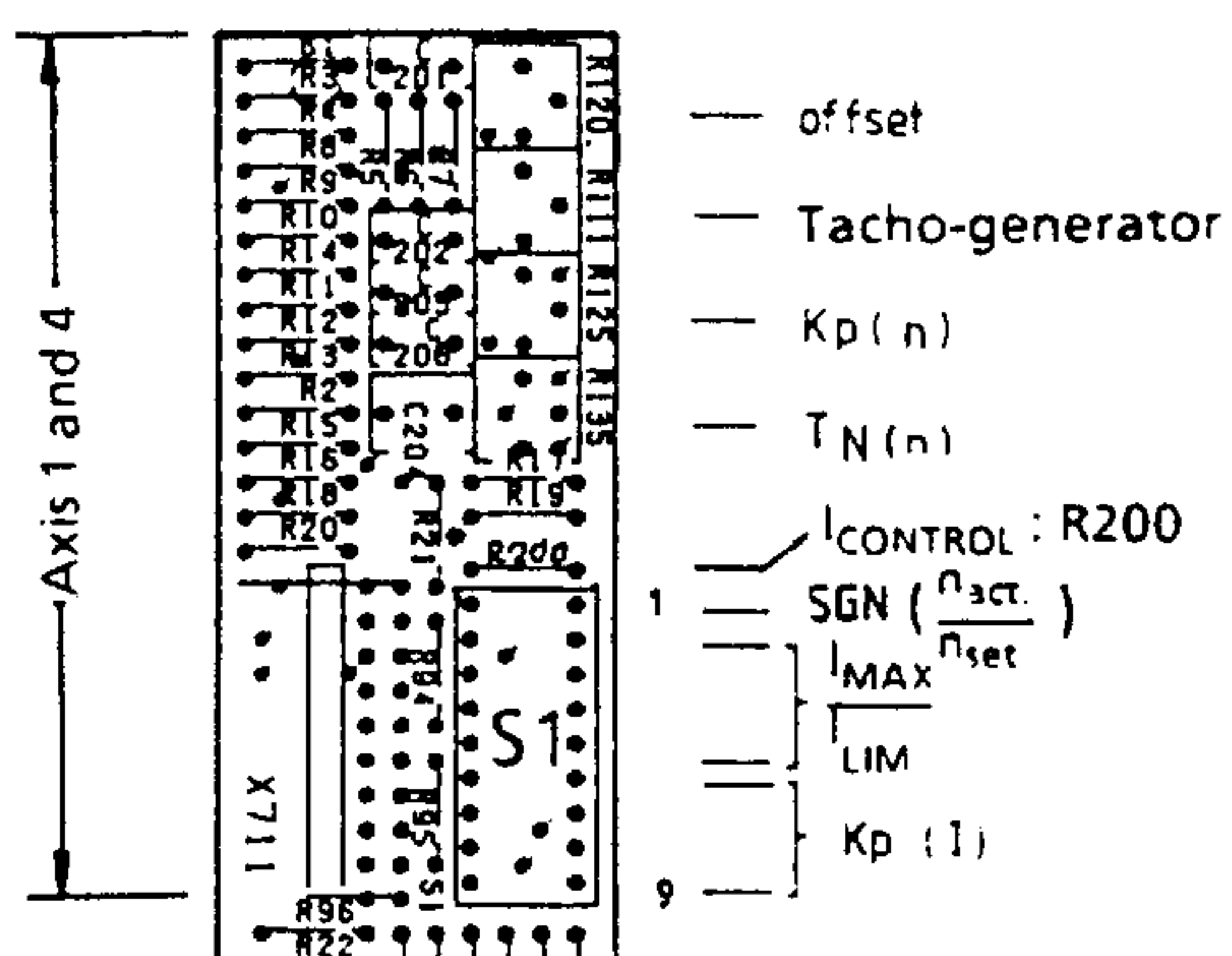

- Insert link R200 in the adjustment module
- Implement axis-specific controller enabling:

- Link X111:65 and X111:9 (axes 1 and 4)
- Link X121:65 and X121:9 (axes 2 and 5)
- Link X131:65 and X131:9 (axes 3 and 6)

Fig. 3.6a

b) 10-pole switch S1

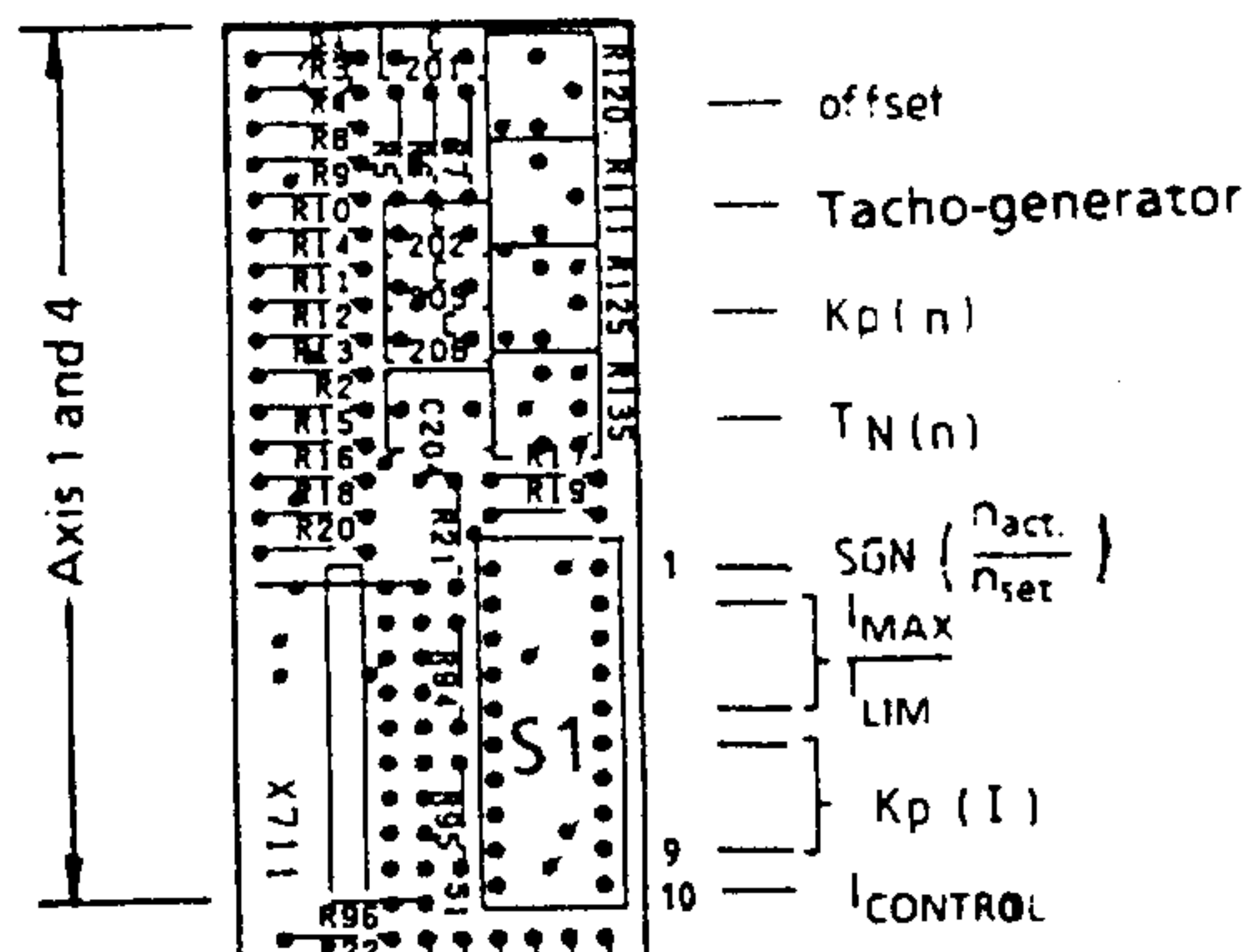

- Set switch S1.10 on adjustment module to ON
- Implement axis-specific controller enabling:

- Link X111:65 and X111:9 (axes 1 and 4)
- Link X121:65 and X121:9 (axes 2 and 5)
- Link X131:65 and X131:9 (axes 3 and 6)

Fig. 3.6b

Operate individual axes on current control (with P component only)

- a) 9-pole switch S1 - Link R200 removed
- b) 10-pole switch S1
 - Set switch S1.10 on the adjustment module to OFF
 - Remove the following resistors from the control module:
 - R263 (axes 1 and 4)
 - R369 (axes 2 and 5)
 - R327 (axes 3 and 6)
 - Implement axis-specific control lock-out:
 - Open X111:65 and X111:9 (axes 1 and 4)
 - Open X121:65 and X121:9 (axes 2 and 5)
 - Open X131:65 and X131:9 (axes 3 and 6)

Current-controlled operation with PI current controller

The P controller alone is not a sufficiently accurate current-control mechanism for special applications which employ pure torque control and do not permit a steady-state deviation. Furthermore, the feedback of the actual speed value to the current setpoint across the short-circuited speed controller (0.5 k Ω in feedback circuit) with max. 600 mV causes an additional control error.

Torque-controlled operation with PI-current controller in which the actual speed value is not influenced can be implemented as follows:

- Activate terminal 6 on the controller module with + 15 V, thus disabling the integral-action component of the speed controller.
- Remove (using pinchers) resistor R9 (1st axis) on the adjustment module. The actual speed value is now decoupled.
- To eliminate the effect of the speed controller offset, the potentiometers for K_p and T_N should be turned as far as possible to the left (minimum gain). The drift should also be compensated ($I^* = 0$ V, test socket T = 0 V).
- The current setpoint is input via terminal 58-8.
- Terminal 56 must be connected to terminal 14.

All other terminals and switches must be set as for speed-controlled operation, i.e. terminals 63, 64, 65 enabled and switch S 1.10 to OFF.

The current limits remain effective in current-controlled operation.

3.1.8 Current setpoint for parallel operation

Variable-speed axis 1 or 4 of the controller module can act as master and feed its current setpoint to current-controlled slave axis 2 and/or 3 (or 5 and/or 6). The following modifications are required on the control module for this purpose:

- Axis 2 or 5 operates as slave:
 - Open link R431
 - Insert link R430
 - Feed -15 V to X121:96 ("Speed control at maximum" deactivated)
- Axis 3 or 6 operates as slave:
 - Open link R449
 - Insert link R448
 - Feed -15 V to X131:96 ("Speed control at maximum" deactivated)

3.1.9 External power supply for controller enabling

The internal power supply for control enabling can be deactivated by removing resistors R20 and R21 from module G0. An external isolated power supply (+24 V) can then be connected via terminal X121:19 (reference potential) and terminal X121:9 of the power supply.

3.1.10 External voltage input for storage of fault memory signals

In order to be able to store fault indications even when the unit is switched off, a non-stabilized voltage of +24 V DC can be applied to terminals X111:11 and X111:15 of the power supply module. The tolerance range for this external voltage is 19 V to 30 V including ripple (see Fig. 3.7)

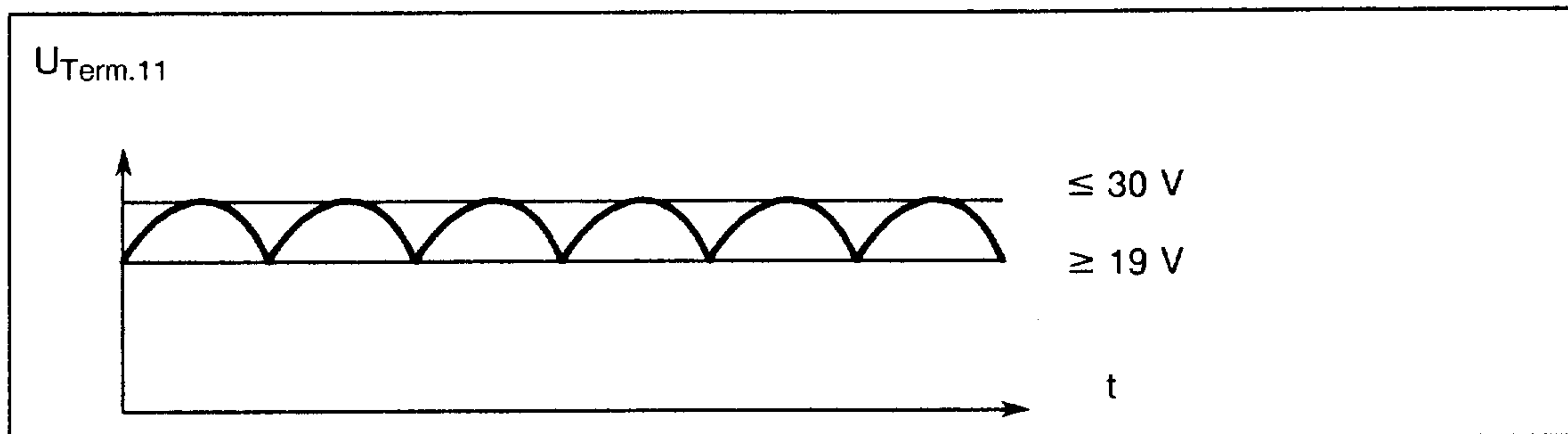

Fig. 3.7

The following description covers the power supplies as shown:

6SC6 100-0GA00	6SC6 100-0GB00
6SC6 100-0GA01	6SC6 100-0GB01
6SC6 100-0GA11	6SC6 100-0GB11

If this function is utilized, it should be noted that **each time** the unit is switched off, the $\pm 15 \text{ V}$ monitoring and the group fault memory will operate and produce a fault indication via the relay contact at terminals 72, 73.1, 73.2 and 74, owing to non-availability of the negative electronics voltage. A distinction must therefore be made between the following cases:

1) The unit is switched off in the absence of a fault signal.

Consequence: The $\pm 15 \text{ V}$ monitoring and the group fault memory operate and cause LEDs +G0-V2 and +G0-V1 to light up. The "Ready" signal at terminals 72, 73.1, 73.2 and 74 disappears and a fault signal is output (see Chapter 3.2.1).

2) The unit is switched off in consequence of a fault signal.

Consequence a: When the unit has been switched off, the $\pm 15 \text{ V}$ fault indication lights up in addition to the original fault lamp. In this case, the $\pm 15 \text{ V}$ fault indication should be ignored.

Consequence b: Only the $\pm 15 \text{ V}$ fault lamp and the group fault memory lamp light up when the unit has been tripped. In this case, the cause of the fault lies in the $\pm 15 \text{ V}$ electronics voltage.

The following description covers the power supplies as shown:

6SC6 100-0GA02	6SC6 100-0GB02
6SC6 100-0GA12	6SC6 100-0GB12

3.1.10 External voltage input for storage of fault memory signals

The ± 15 V-monitor comes into action only when there is a faulty ± 15 V (also when switching off the equipment)

If this is the case, then the resistance R900 should be removed from the board "Power supply and monitor". The board then exactly corresponds to:

6SC6 100-0GA00/01/11

6SC6 100-0GB00/01/11

3.1.11 Changing of variable components in the speed setpoint channel

The smoothing time constant in the speed setpoint channel can be increased by the addition of capacitors C301 (axes 1 and 4), C302 (axes 2 and 5) and C303 (axes 3 and 6) on the controller module (see Fig. 3.8).

The input resistance of the speed setpoint channel can be adjusted by the addition of R450 (axes 1 and 4), R461 (axes 2 and 5) and R471 (axes 3 and 6)

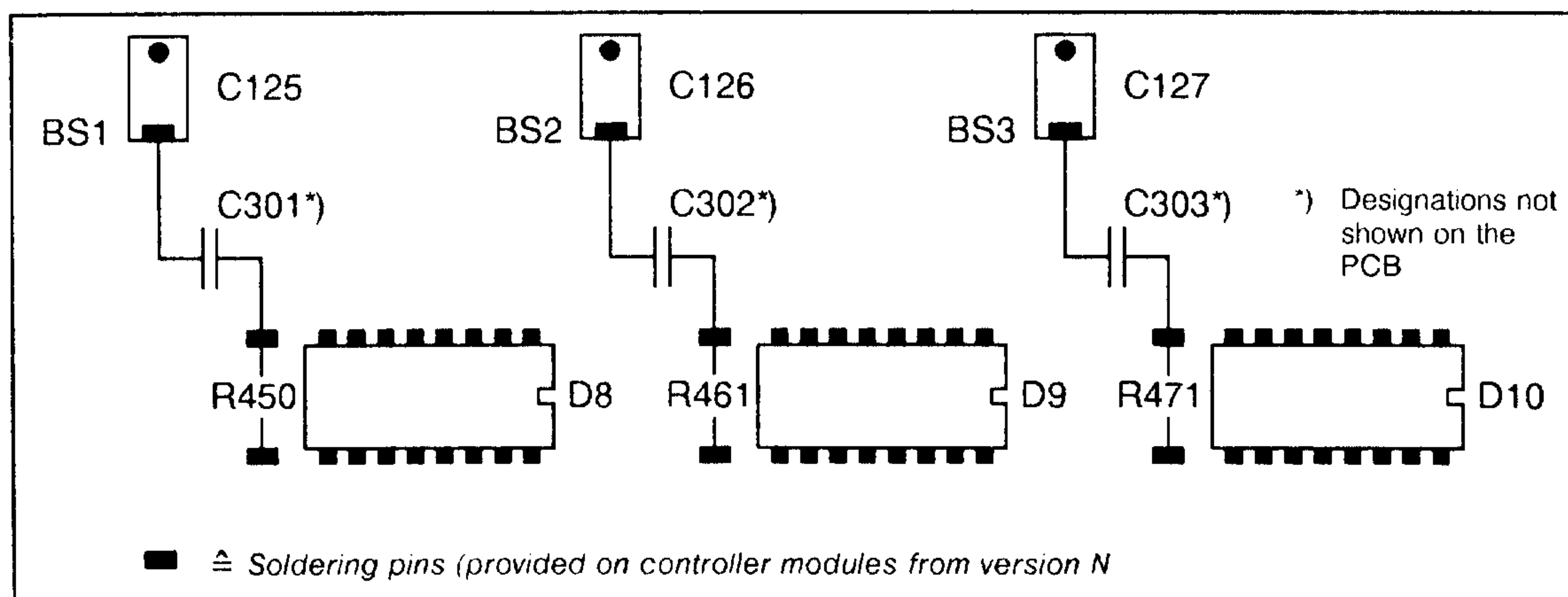

Fig.3.8

3.1.12 Monitoring circuit "Speed controller at stop"

If the speed controller is at the stop for more than approx. 200 ms, pulse enabling and controller inhibition will be initiated.

If necessary, this monitoring time can be extended by increasing the resistance value of R605 (axes 1 and 4), R646 (axes 2 and 5) and R656 (axes 3 and 6) on the controller module (as of version N on soldering pins).

Monitoring time for axis 1 (example):

$$\frac{t}{s} \approx \frac{R605}{M\Omega} \times 0.55$$

3.1.13 Operation of control axes without power circuit module

If no motor is connected to an axis, pins 11 and 12 of connector X311 (for axes 1 and 4), X321 (for axes 2 and 5) or X331 (for axes 3 and 6) on the controller module (DUBOX connectors) must be short-circuited (see Fig. 3.9)

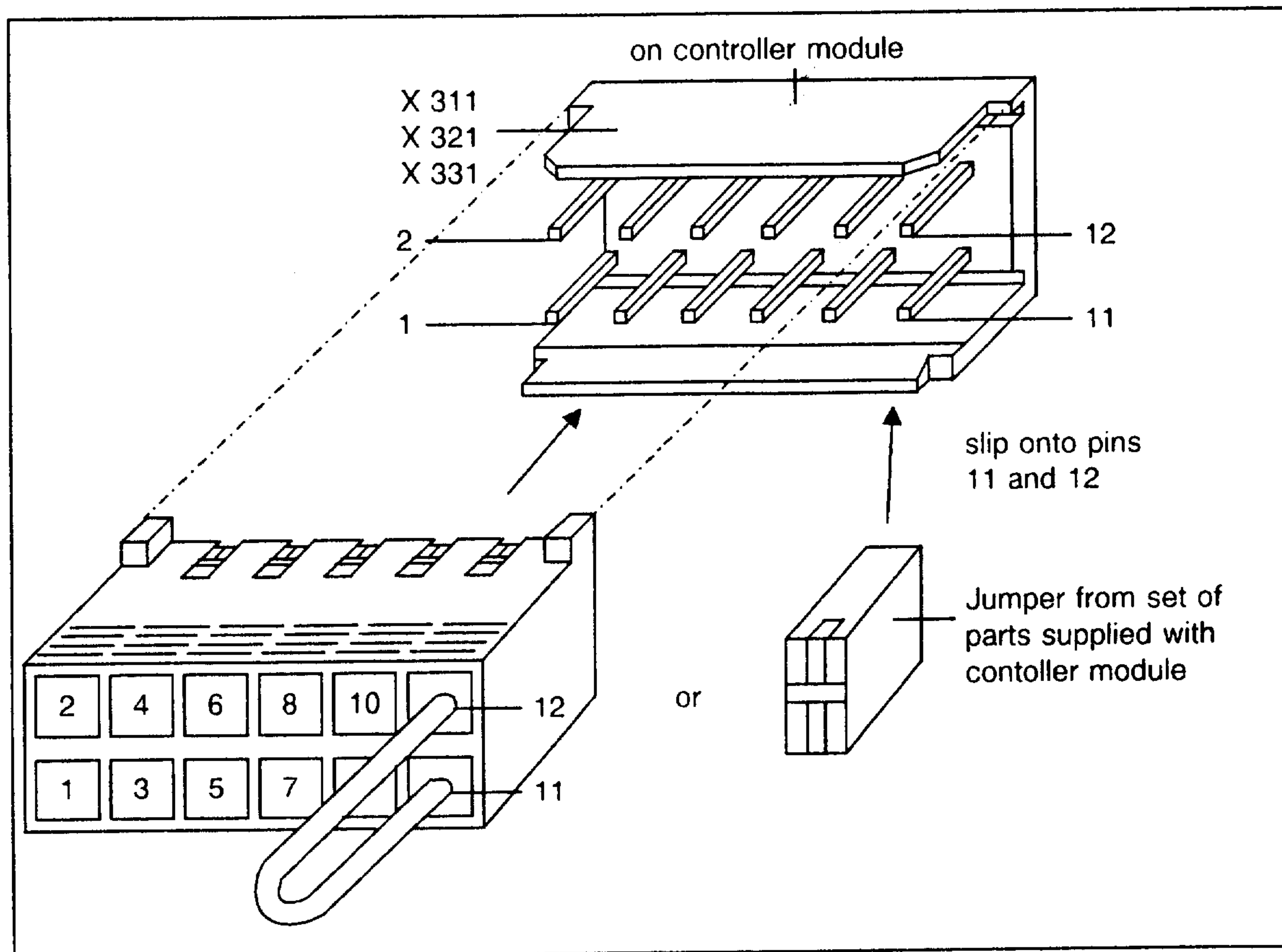

Fig. 3.9 Terminating connector

The pulse cables must be provided with a terminating connector in order to prevent disturbances during operation without power circuit module.

For all control modules:

Order No.: 6SC6101-0XB10 (16-way)
6SC6101-0XB12 (34-way)

Adapter 1 × 34-way to 2 × 16-way
Order No.: 6SC6101-0LA17

3.1.14 Testing the load cycle

The I^2t curve (Fig. 3.10) describes the following monitoring function:

The actual current value is approximately squared and the result subsequently integrated. If the actual current value is larger than 1.1 times the rated current, the voltage excursion of the integrator is negative, otherwise it is positive.

If the integrator, starting from rest (start-up of the unit or reset command), has a negative total voltage excursion of about -15 V , the current setpoint limitation takes effect.

To calculate the total voltage excursion for a given load cycle, proceed as follows:

- 1) Divide the load cycle into time sections Δt_i ($i = 1, \dots, n$) with constant current I .
- 2) Use the following formula to calculate the part voltage excursion ΔU_i ($i = 1, \dots, n$) for each time section depending on the sign:

$$\frac{\Delta U_i}{\text{V}} = \frac{\Delta t_i}{\text{s}} \cdot \left[2,2 - 2 \cdot \left(\frac{I}{I_{\text{rated}}} \right)^2 \right]$$

- 3) Add the part voltage excursions according to sign.
- 4) Total voltage excursion
 - $< -15\text{ V} \rightarrow$ Load cycle impermissible
 - $> -15\text{ V} \rightarrow$ Load cycle permissible

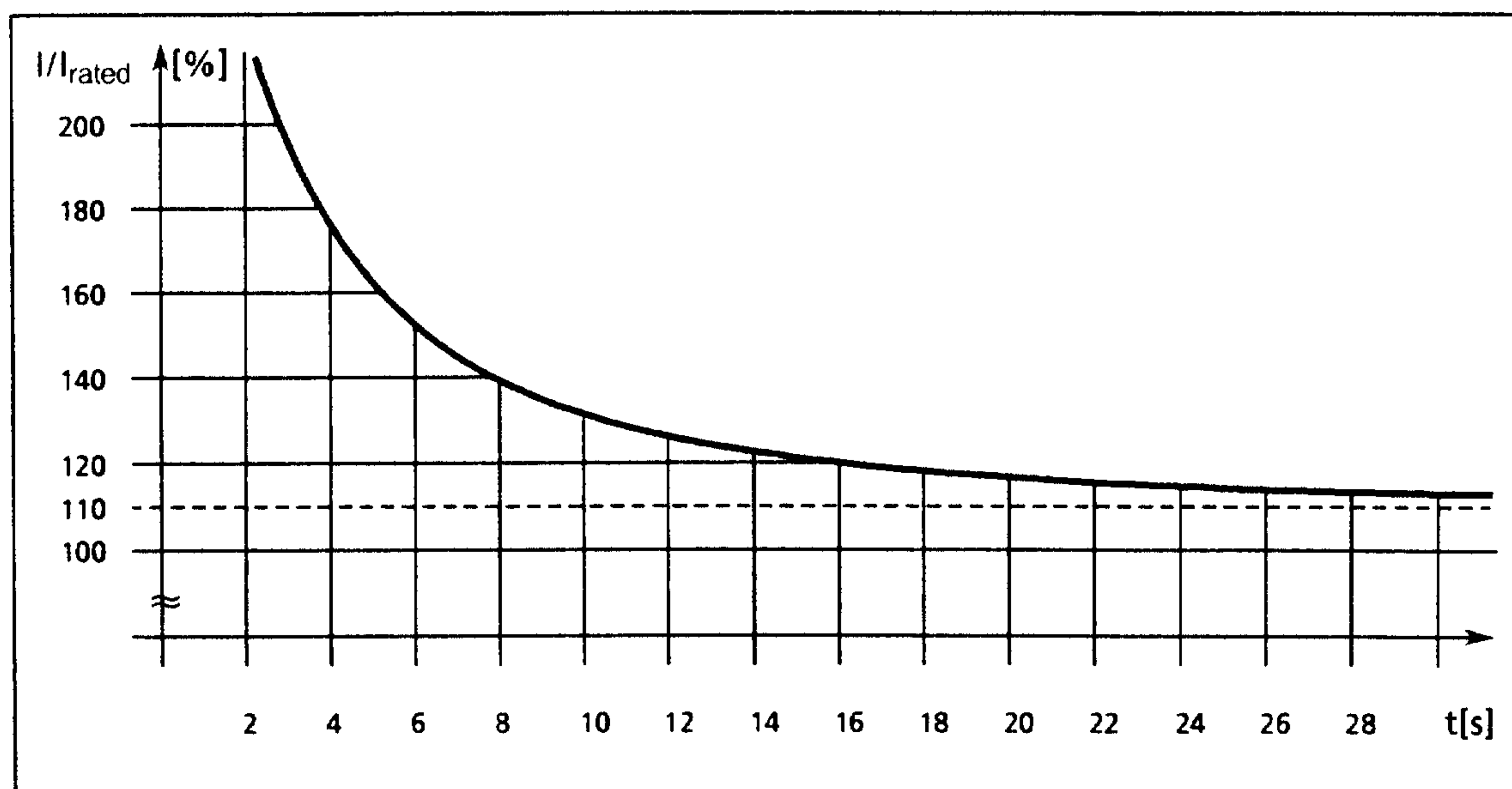

Fig. 3.10 I^2t -curve $\hat{=}$ thermally permissible time duration of overcurrent

3.2 Signals

No fault indication will appear any earlier than about 1 s after power-up.

3.2.1 Ready/fault signal

The ready signal can be converted into a fault signal by removing diode V13 on power supply module G0.

A fault indication occurs if the ± 15 V monitoring, the DC link voltage monitoring ($U_{ZK} \gg$) or if the "Speed controller at maximum" monitoring operate.

The ready indication occurs if none of the aforementioned fault conditions applies and if the enable signal is present at terminals 63 and 64.

3.2.2 Resetting the fault memories

The internal fault memories can be reset by applying an M signal (0 V reference) to terminal R of connector X111 on the power supply module or by switching the unit off and on again.

NOTE

Before switching the unit on again, allow the DC link voltage to drop to at least 25 V to ensure generation of an internal resetting signal. The delay is dependent upon the inverter design and is approximately 10 s.

3.2.3 I²t and motor overtemperature signals

For this signal, terminal 5 with location code +G0-X111 provides an open collector output which is common for all axes. A relay can be connected to this output and to terminal 7 or some other power supply (connect freewheeling diode in parallel!) (Fig. 3.11). The relay is picked up when the signal is active.

Relay data: $U_N = 12$ V or 15 V, $I_N \leq 50$ mA when using the internal voltage at terminal 7.
When using an external voltage of 24 V, a 24 V relay can be used ($U_N = 24$ V, $I_N \leq 50$ mA).

If terminal 5 is direct-connected to the programmable logic controller (PLC), a pull-up resistor of 1.0 k Ω (1.0 W) must be connected to terminals 5 and 7 or some other power supply (indication active $\hat{=}$ L signal) (Fig. 3.12).

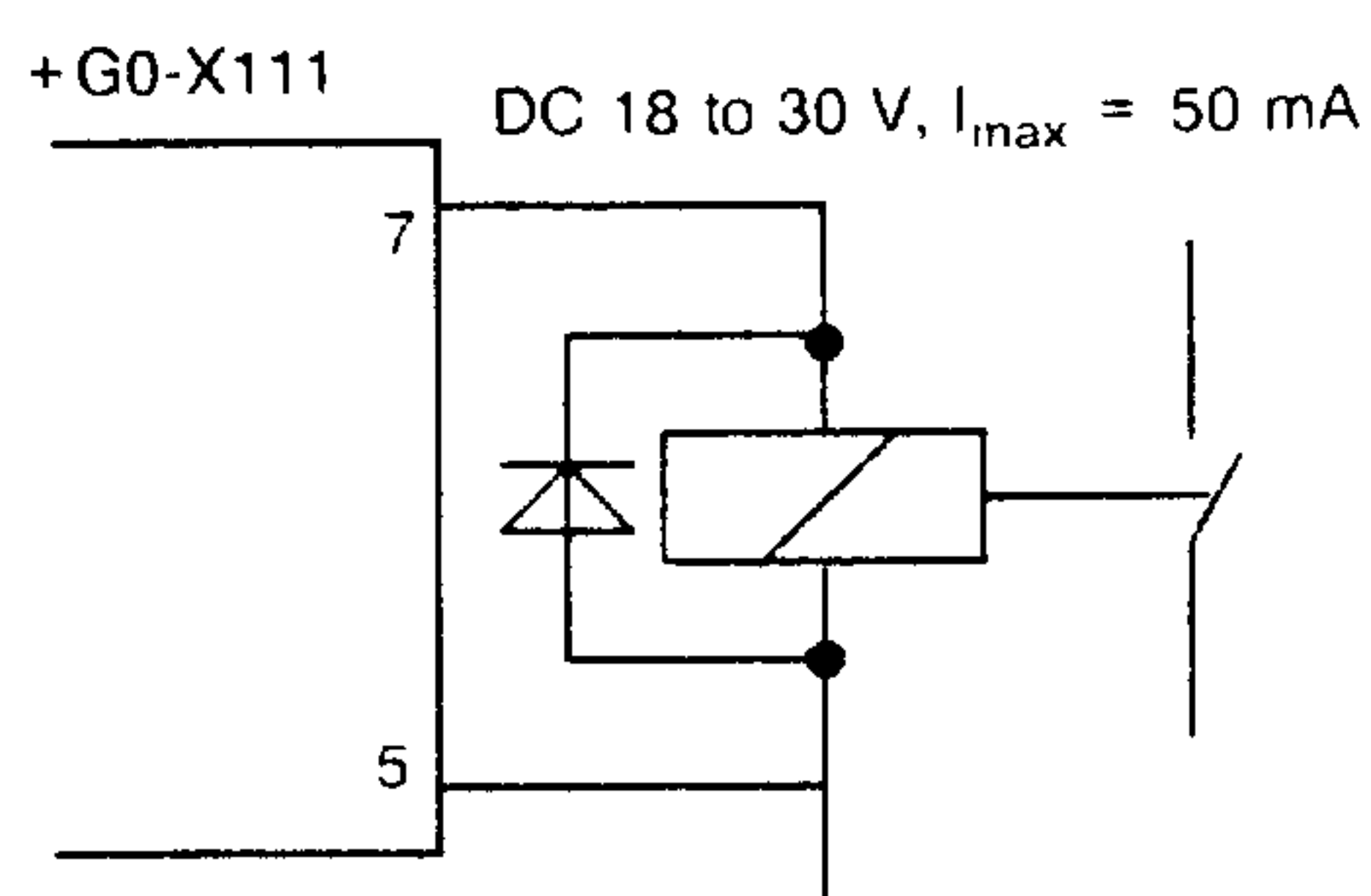

Fig. 3.11 Connection of a relay

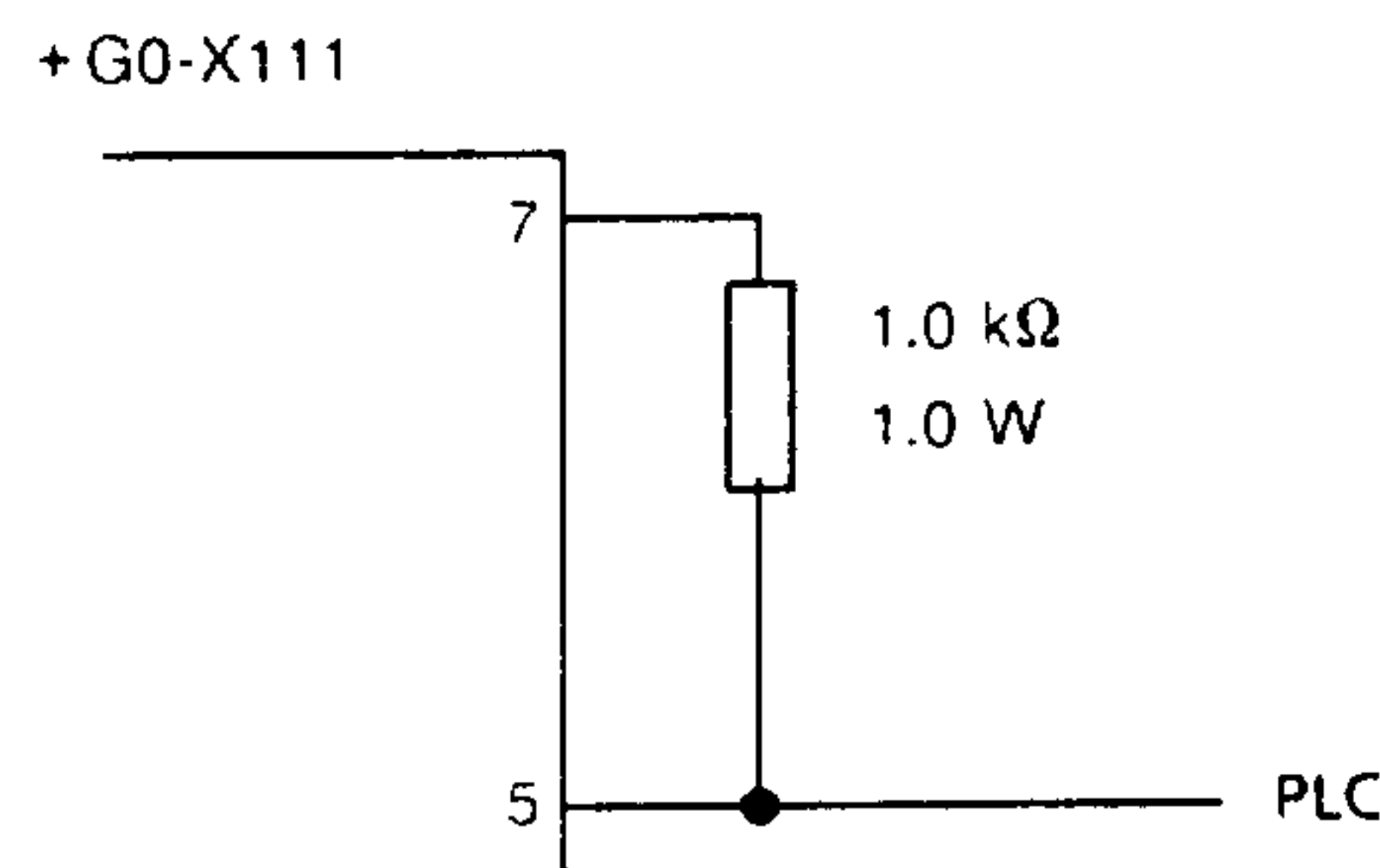

Fig. 3.12 Connection to the PLC resistor only necessary with power supplies 6SC6100-0GA00 and -0GB00

3.2.3 I²t and motor overtemperature signals

Note: The motor overtemperature indication has no effects in the unit.

The I²t indication is followed with a delay by a current reduction to the thermally permissible continuous current of the power section.

The unit does not cut out. To clear the fault indication, the unit must either be switched off or reset.

3.3 Test sockets, display elements

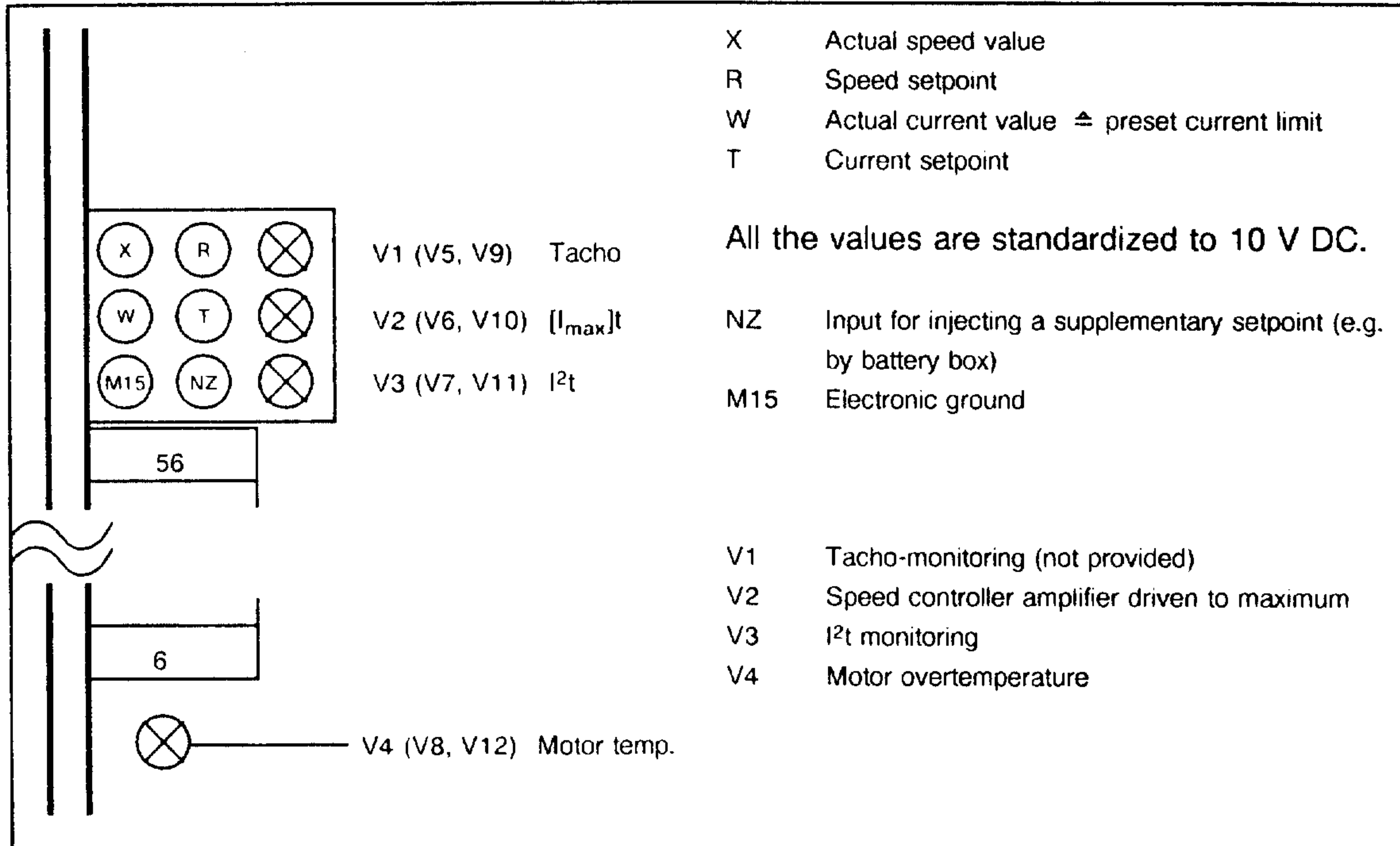

Fig. 3.14 Test sockets and display elements on controller modules N1 and N2

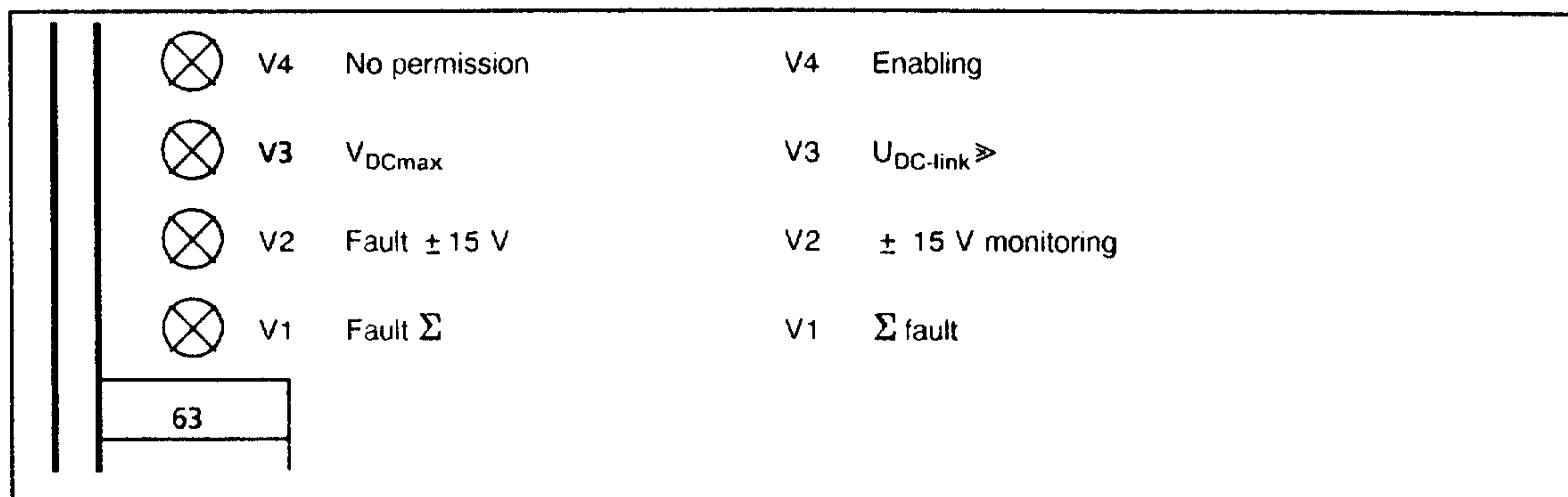
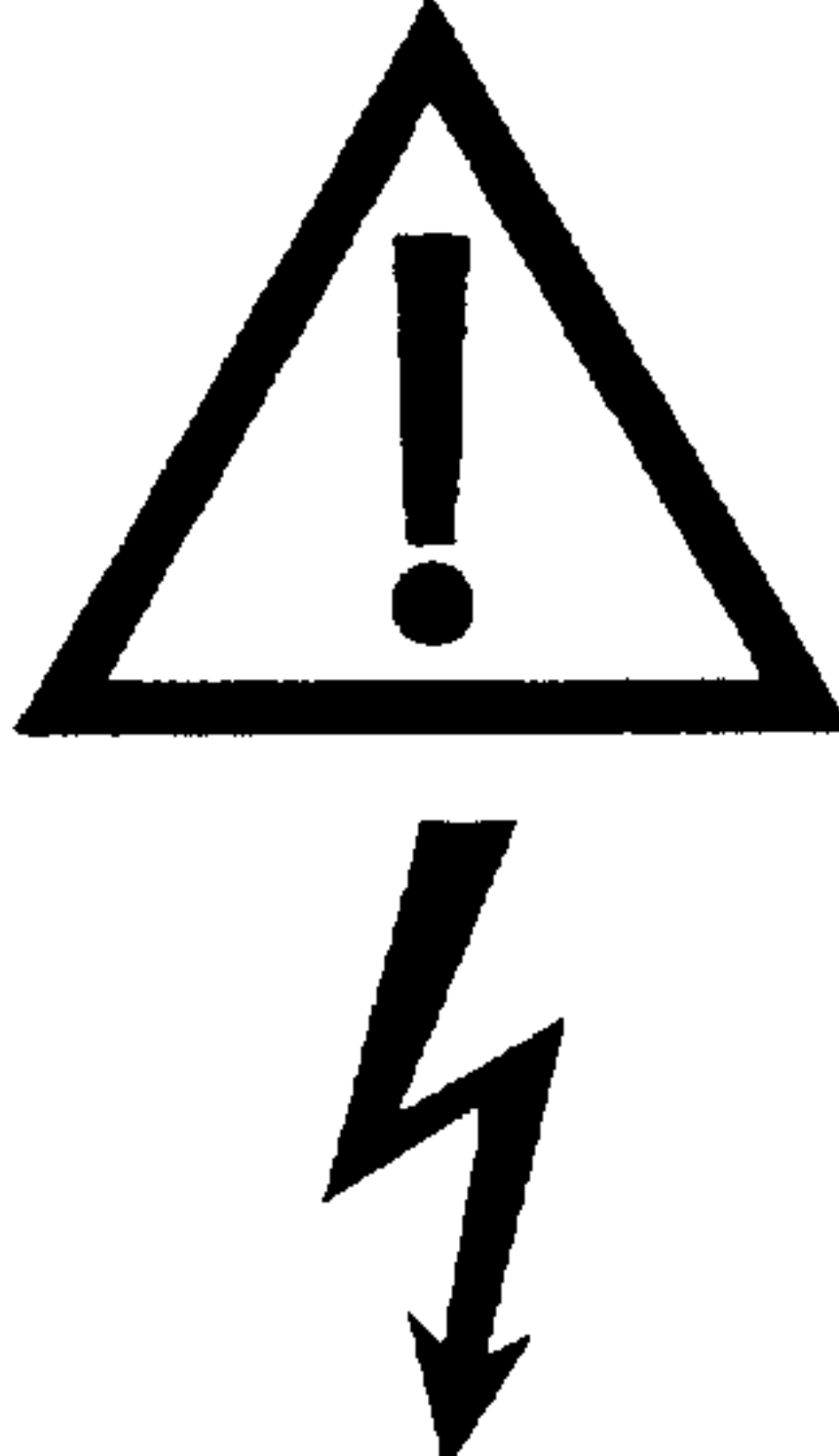
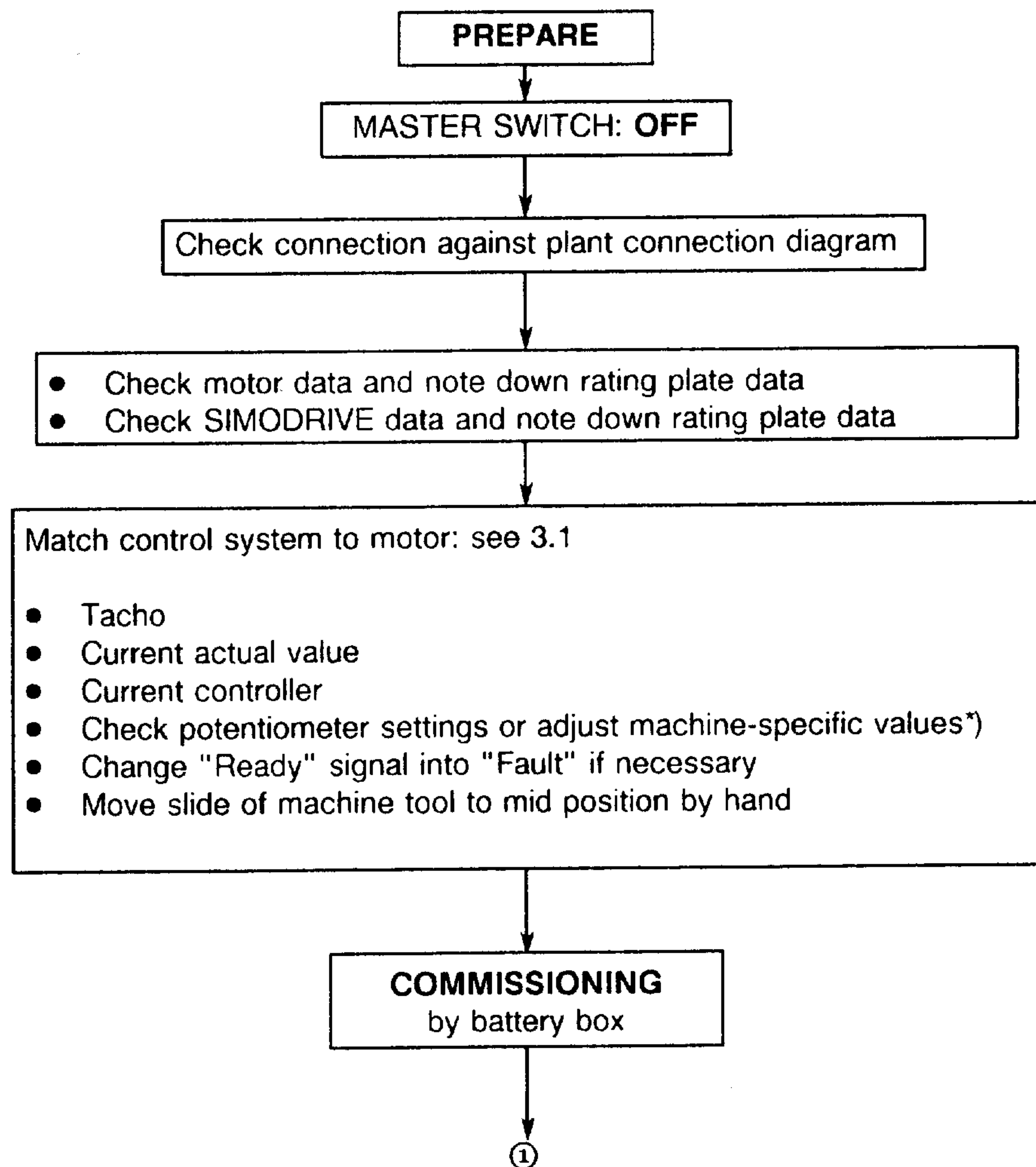

Fig. 3.15 Display elements on power supply module G0

3.4 Start-up

	WARNING
	<p>Safe operation is dependent upon proper handling and installation by qualified personnel under observance of all warnings contained in this instruction manual.</p> <p>The DC link capacitors cause high voltage to persist for approx. 4 minutes after disconnection from the supply.</p> <p>When operating on the open unit, please note that live parts are exposed.</p> <p>Parts of the equipment may be live even when the motor is stationary.</p> <p>Work on the unit must only be performed by qualified personnel.</p> <p>Non-observance can result in death, severe personal injury or substantial property damage.</p>



*) If the values of the speed controller parameters are not known, they must be determined by optimization by skilled personnel.

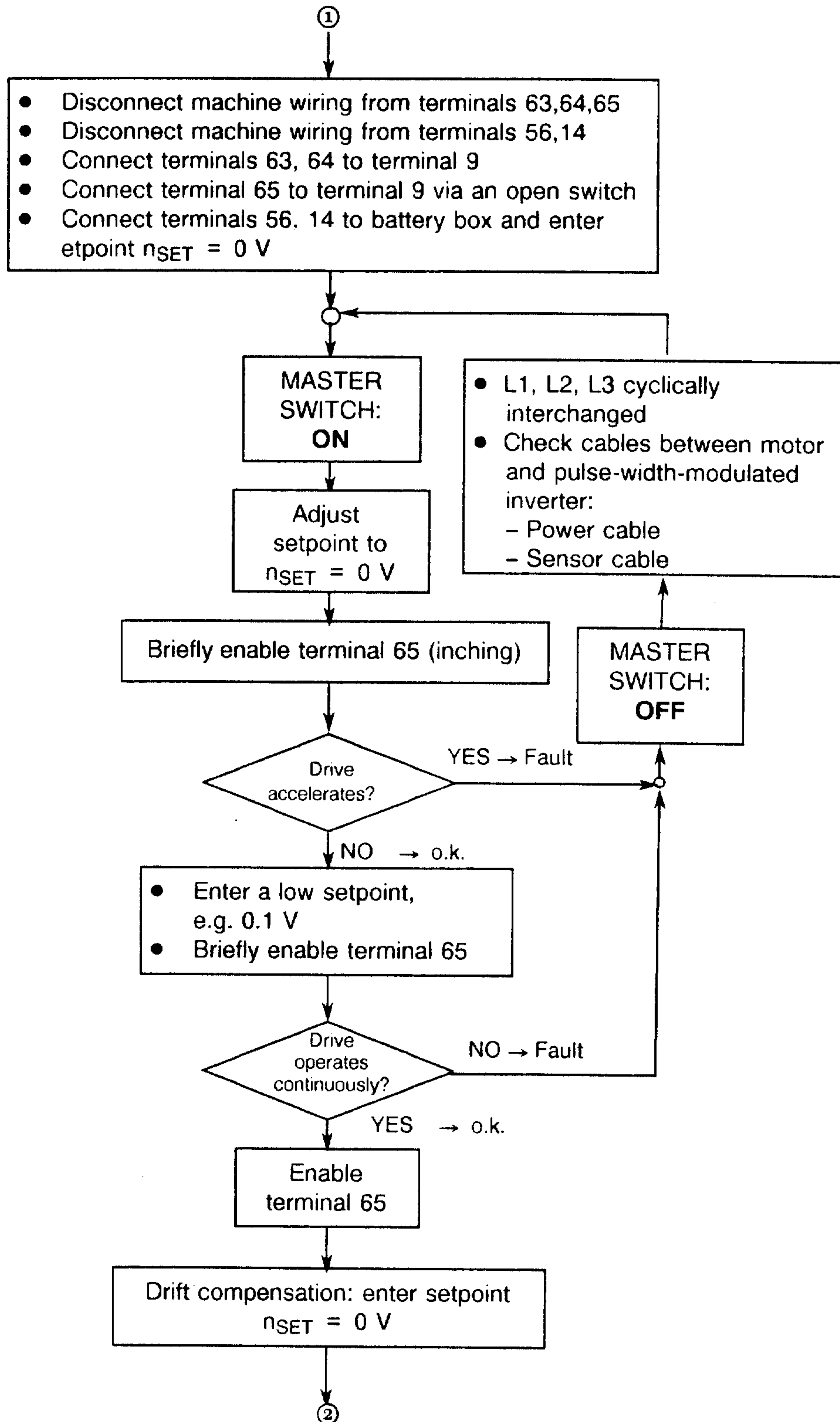

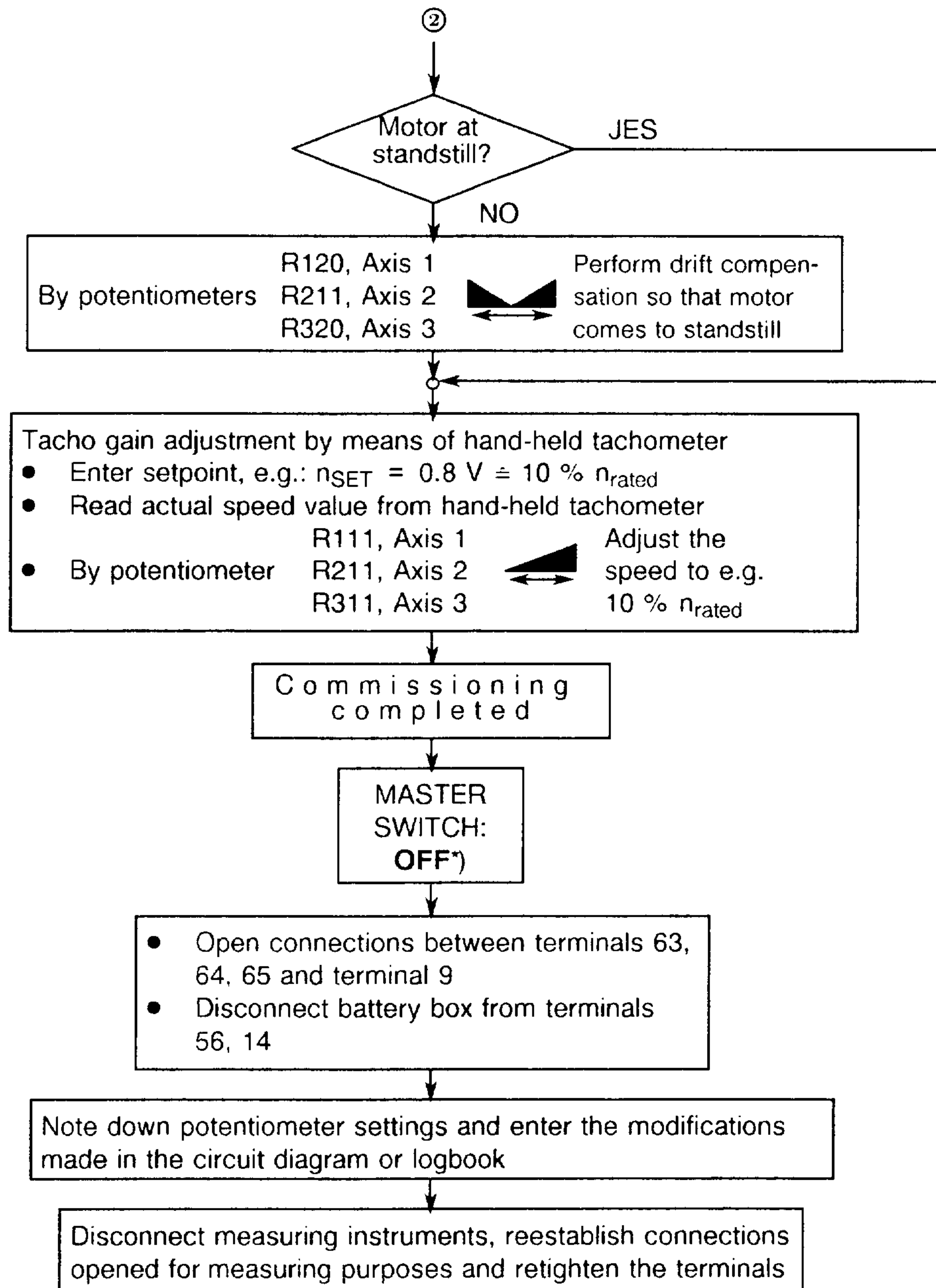

*)

	CAUTION
	<p>In the event of faults, the DC-link circuit will be live for approx. 4 minutes after disconnection of the unit. Before carrying out any manual work on the unit with the cover removed, the master switch must be opened and the DC-link circuit discharged</p>

4 Maintenance

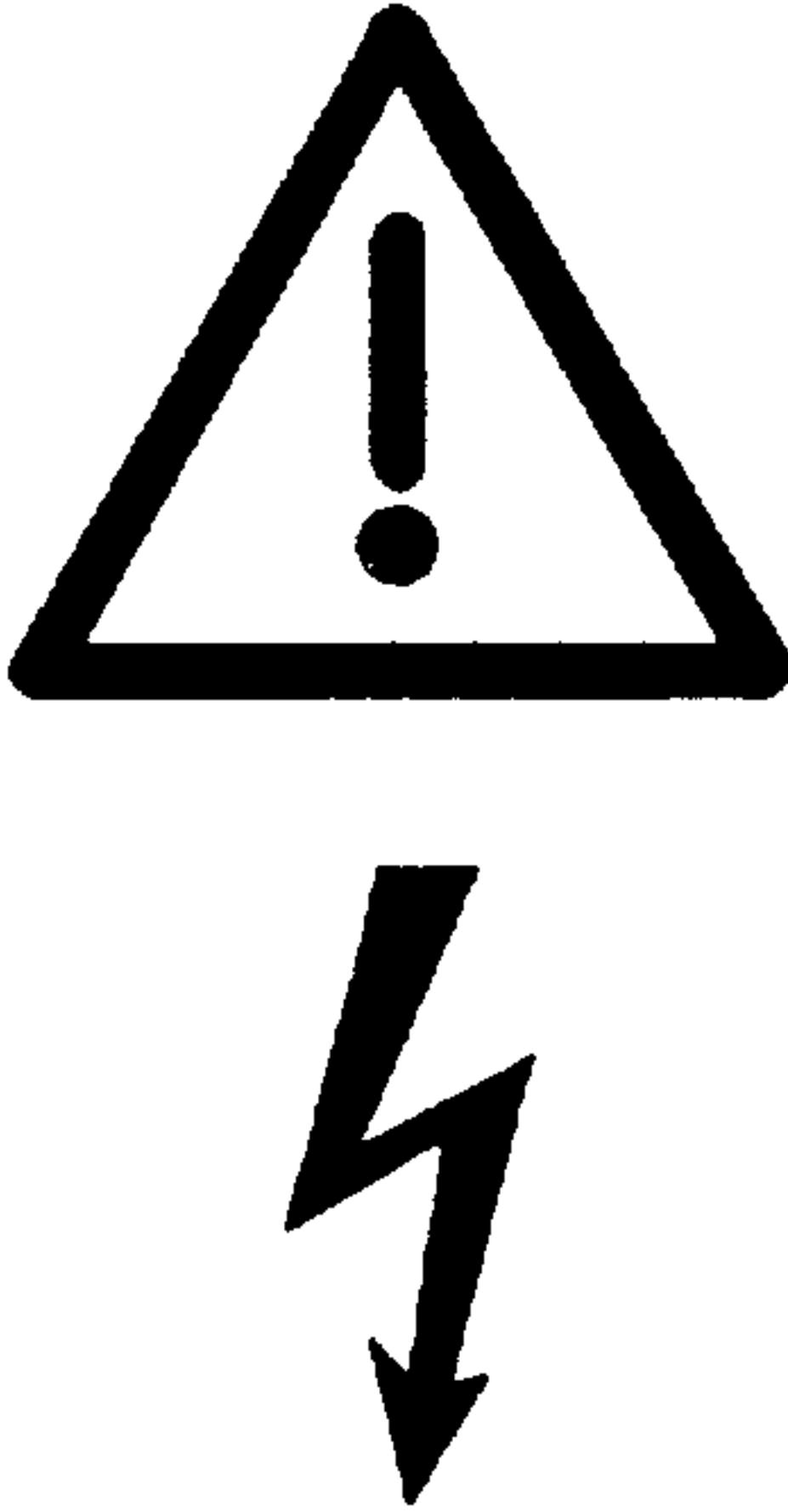
	WARNING
	<p>Hazardous voltages are present in this electrical equipment during operation. Failure to properly maintain the equipment can result in death, severe personal injury or substantial property damage.</p> <p>The instructions contained in this chapter and product labels have to be followed.</p> <ul style="list-style-type: none"> • Maintenance shall be performed only by qualified personnel. • Always de-energize and ground the equipment before maintenance. The DC link capacitors cause high voltage to persist for approx. 4 minutes after disconnection from the supply. Parts of the equipment may be live even when the motor is stationary. • Use only authorized spare parts in the repair of the equipment.

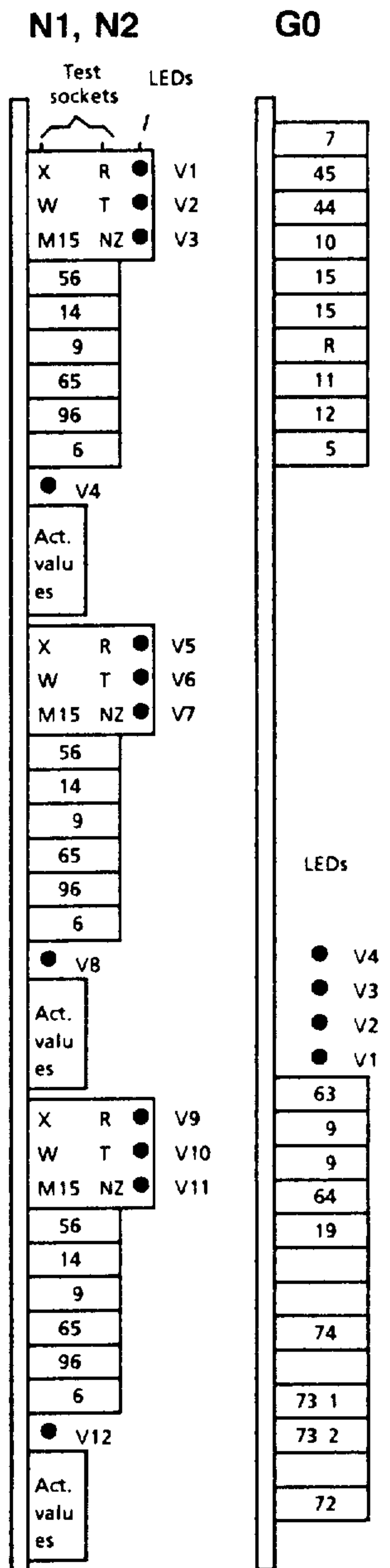

Modules for module slots N1, N2 and G0

4.1 Maintenance instructions

The transistor pulse-width-modulated inverter does not require any maintenance.

The bearings of the unit fans are permanently lubricated.

4.2 Faults

Type of fault	Displays	Meaning	Possible causes
Surface finish is poor or inaccurate positioning			Motor defective (e.g. does not run smooth with low setpoints). P amplifier of speed controller set too low (potentiometer R125, R225, R325); mutual interference of axes (due to wrong shielding or wrong installation of earth wire)
Fuses blow	F10, F110 or F310 blow		Fault in power section, check motor Remedial action: Replace module
	F247 blows		Fault in power supply and monitoring system or in the DC link voltage monitoring circuit 0.3/30 kW (G10) Remedial action: Replace both modules

Table 4.1 a

Type of fault	Displays	Meaning	Possible causes
Axis does not move even though the reference value is applied to terminal 56	Green LED + G0-V4 lights up, red LEDs do not light up	No enabling signal at terminals 63 and/or 64	Customer's interlocking circuit activated R20, R21 disconnected
	No LED lights up		External main fuse blown or not inserted or power supply defective
	LED + G0-V1 lights up, red LEDs (N ₀) do not light up + G0-V2 lights up + G0-V3 lights up	 ± 15 V out of tolerance or not available Voltage of DC-link circuit too high	 Supply voltage too high, load inertia too high, current limit mismatched
	Red LED + G0-V1 lights up Red LED + N ₀ -V1* lights up	Tacho monitoring circuit responded	Tacho or tacho cable defective
	Red LED + G0-V1 lights up Red LED + N ₀ -V2* lights up	Controller monitoring circuit responded (speed controller amplifier driven to maximum)	Motor line interrupted, mechanical system blocked, cable between motor and inverter defective, power section (A1 to A6) defective, ribbon cable between control and power section defective, motor winding connected in the wrong order
Axis moves, but unit is de-energized again	Red LED + G0-V1 lights up Red LED + G0-V3 lights up	Overvoltage in DC-link circuit during braking	Load inertia too high, current limit not matched to motor, motor speed exceeds rated speed, resistor for voltage limitation overloaded, no loading by frictional forces, vertical axis without weight balance.
	Red LED + G0-V1 lights up Red LED + N ₀ -V2* lights up	Accelerating or reversing too long (< 200 ms)	Current limitation set too low or load inertia too high
	Red LED + N ₀ -V3* lights up or Red LED + N ₀ -V4* lights up	I ² t-monitoring circuit responded Motor overtemperature circuit responded	Effective torque too high, ACC/DEC too often, machining forces too high, motor defective

Table 4.1 b

N₀ = N1, N2



+ N₀-V1* ≙ + N₀-V1/-V5/-V9 ≙ Tacho monitoring + G0 - V1 ≙ Σ-fault
+ N₀-V2* ≙ + N₀-V2/-V6/-V10 ≙ Speed controller amplifier + G0 - V2 ≙ ± 15 V
+ N₀-V3* ≙ + N₀-V3/-V7/-V11 ≙ I²t-monitoring + G0 - V3 ≙ U_{DC-link} ≧
+ N₀-V4* ≙ + N₀-V4/-V8/-V12 ≙ Motor overtemperature + G0 - V4 ≙ Enablings

4.3 Spare parts

Function	Designation	Order No.
Power supply and monitoring	G0	6SC6100-0GA11
Power supply and monitoring including voltage limitation G10 (0.3/30 kW)	G0	6SC6100-0GB11
DC-link voltage limitation G20 (0.9/90 kW)	A0.2	6SC6100-0AB00
Resistor for G10, G20	-	6SY9058
Controller, analog with adjustment module	1 axis 2 axes 3 axes	N1, N2 6SC6100-0NA01 6SC6100-0NA11 6SC6100-0NA21
Adjustment module separately	1 axis 2 axes 3 axes	- 6SC6100-0SA01 6SC6100-0SA11 6SC6100-0SA21
Power modules	3 / 6 A 3 / 6 A 3 / 6 A 8 / 16 A 8 / 16 A 8 / 16 A 20/40 A 30/60 A 40/80 A 70/140 A 70/140 A 90/180 A 120/240 A 200/400 A 200/400 A	1 axis 2 axes 3 axes 1 axis 2 axes 3 axes 1 axis 1 axis 1 axis 1/2 axis (L1 + L3) 1/2 axis (L2 + L3) 1/3 axis 1/3 axis 1/6 axis L + 1/6 axis L-
	A1 to A 10	6SC6103-0SE30 6SC6103-0SG30 6SC6103-0SN30 6SC6108-0SE01 6SC6108-0SG01 6SC6108-0SN00 6SC6120-0FE00 6SC6130-0FE00 6SC6140-0FE00 6SC6170-0FC00 6SC6170-0FC50 6SC6190-0FB00 6SC6190-0FB60 6SC6190-0FA01 6SC6190-0FA51
Pulse distributor for power section 200/400 A	-	6SC6190-0FU00
Rectifier	90 A, 180 A	V0 6SY9056
Capacitor	6000 μ F / 350 V	C0.1 to C0.5 6ZY1073-0AA00
Fan	Typ 3314 / 24 V DC 92 x 92 mm 120 x 120 mm	E0.1 to E0.5 6SY9057 6ZY1073-1AA00
Wiring material	(assembly)	- 6SC6101-0SA00
Wiring accessories	Control for 1 axis	- 6SC6101-0SA03
Ribbon cable (only for 6SC6101-2. to 6SC6101-4.)		
	50-pole to 3 x 16-pole	- 6SC6101-0LA00
	50-pole to 1 x 34-pole + 1 x 16-pole	- 6SC6101-0LA01
	50-pole to 1 x 16-pole + 1 x 34-pole	- 6SC6101-0LA04

Table 4.2 Spare parts

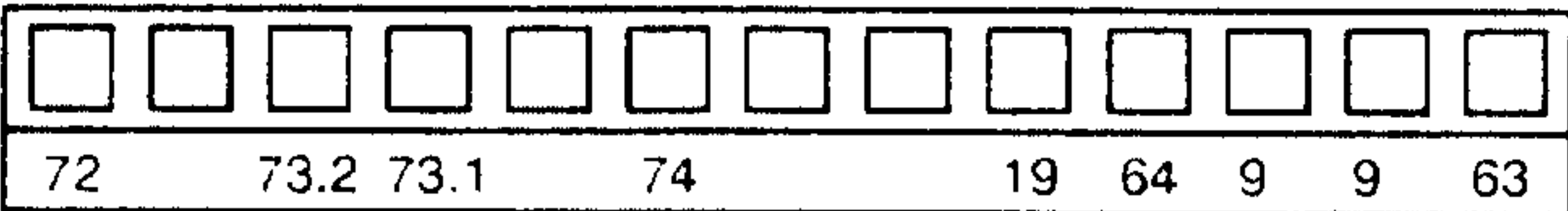
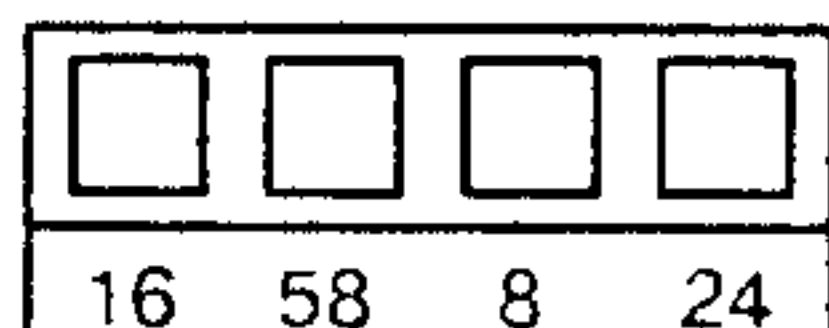
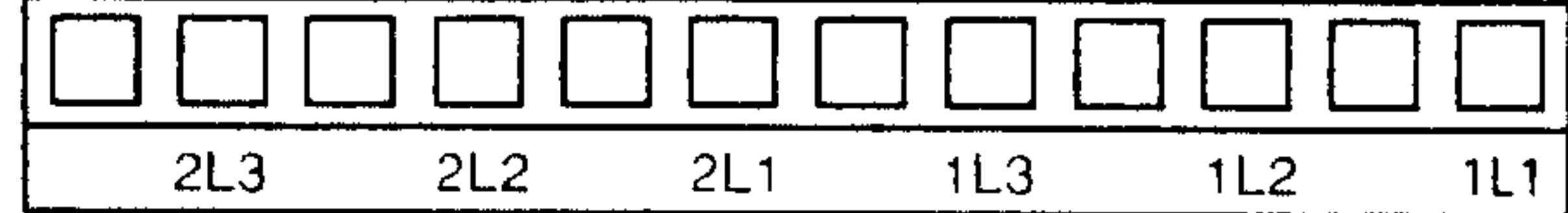
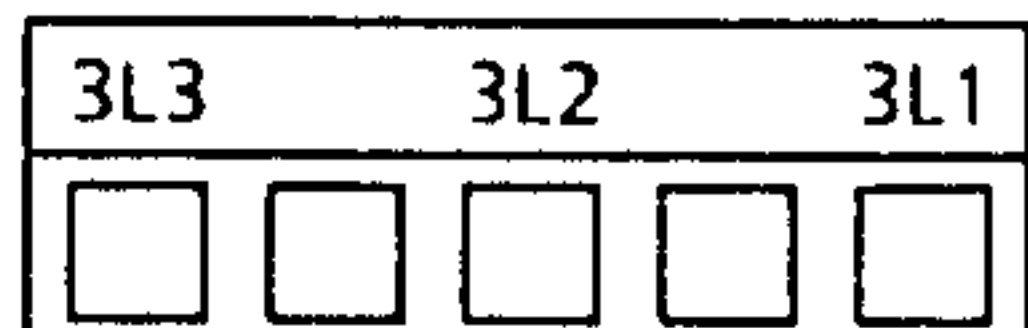
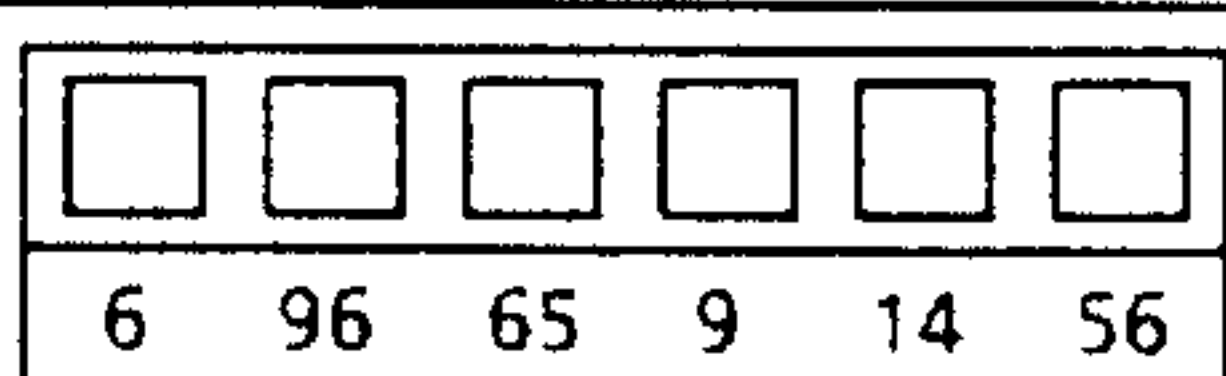
4.4 Connectors

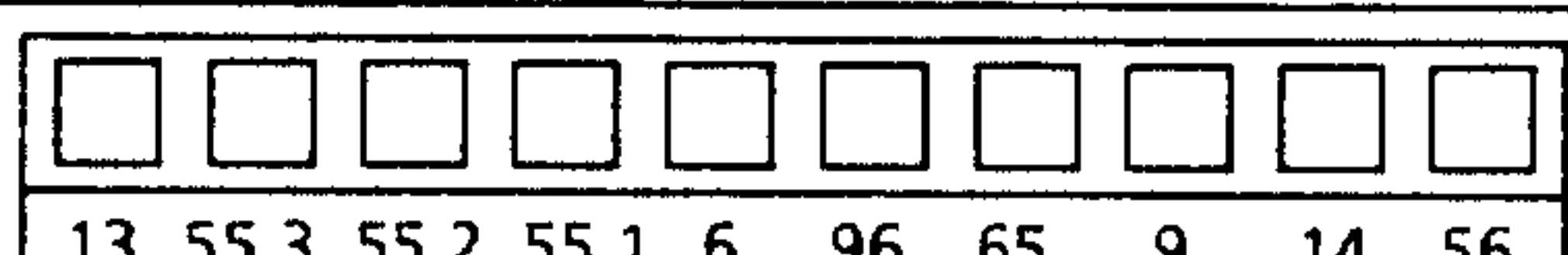
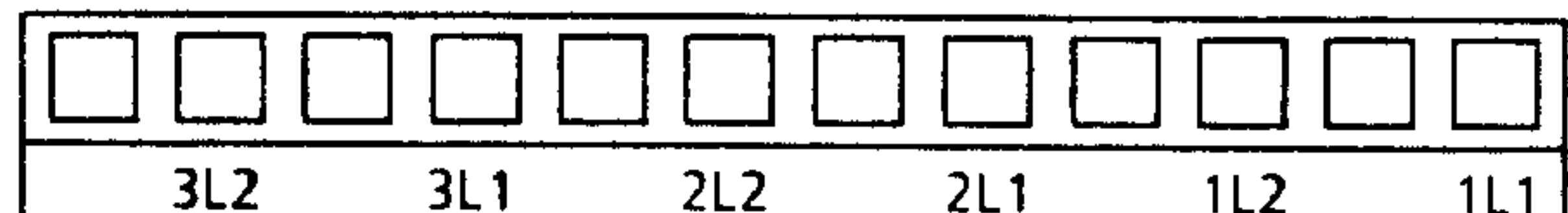
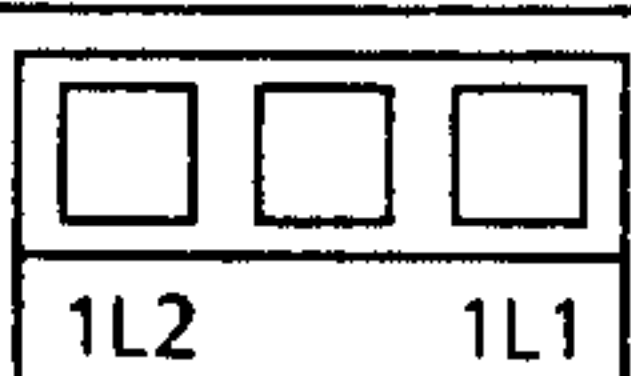
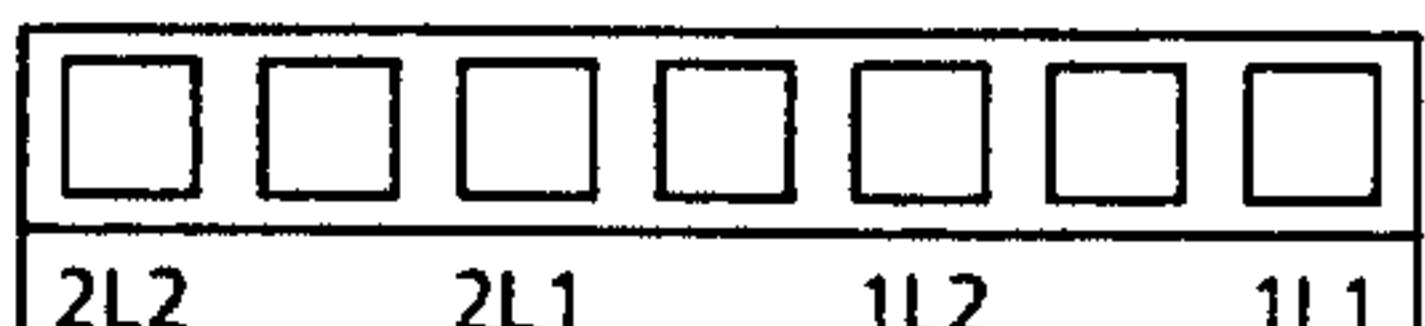
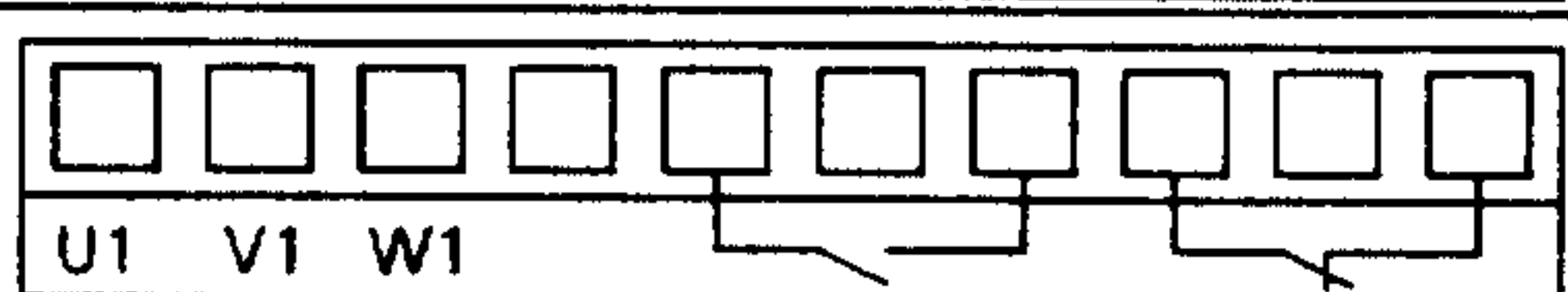
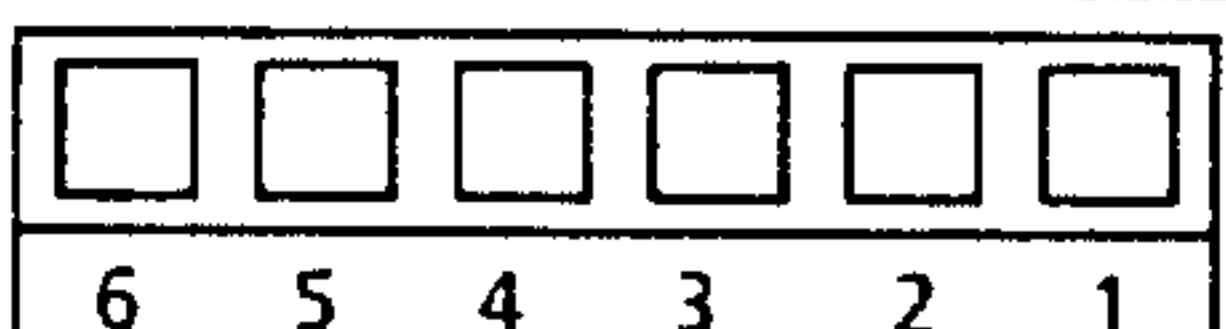
Version Order No.	Connectors	Location	Cont. in:
462 000.0109.01 6SC6101-0XC01		G0 X 121	6SC61 6RB21
462 000.0109.02 6SC6101-0XC02		N1/N2 X 411 X 421 X 431	6SC61 6RB21
462 000.0109.03 6SC6101-0XC03		A. X 231	6SC61
462 000.0109.04 6SC6101-0XC04		A. X 232	6SC61
462 000.0109.05 6SC6101-0XC05		N1/N2 X 111 X 121 X 131	6SC61
462 000.0109.06 6SC6101-0XC06		G0 X 111	6SC61 6RB21
462 000.0109.07 6SC6101-0XC07		N1/N2 X 111 X 121 X 131	6RB21
462 000.0109.08 6SC6101-0XC08		A. X 231	6RB21
462 000.0109.09 6SC6101-0XC78		A. X 231	6RB21
462 000.0109.10 6SC6101-0XC10		A. X 231	6RB21
462 000.0109.11 6SC6101-0XC11		A 0.3 X 126	6SC61 6RB21
462 000.0109.12 6SC6101-0XC12		A 0.2 X 501	6SC61 6RB21

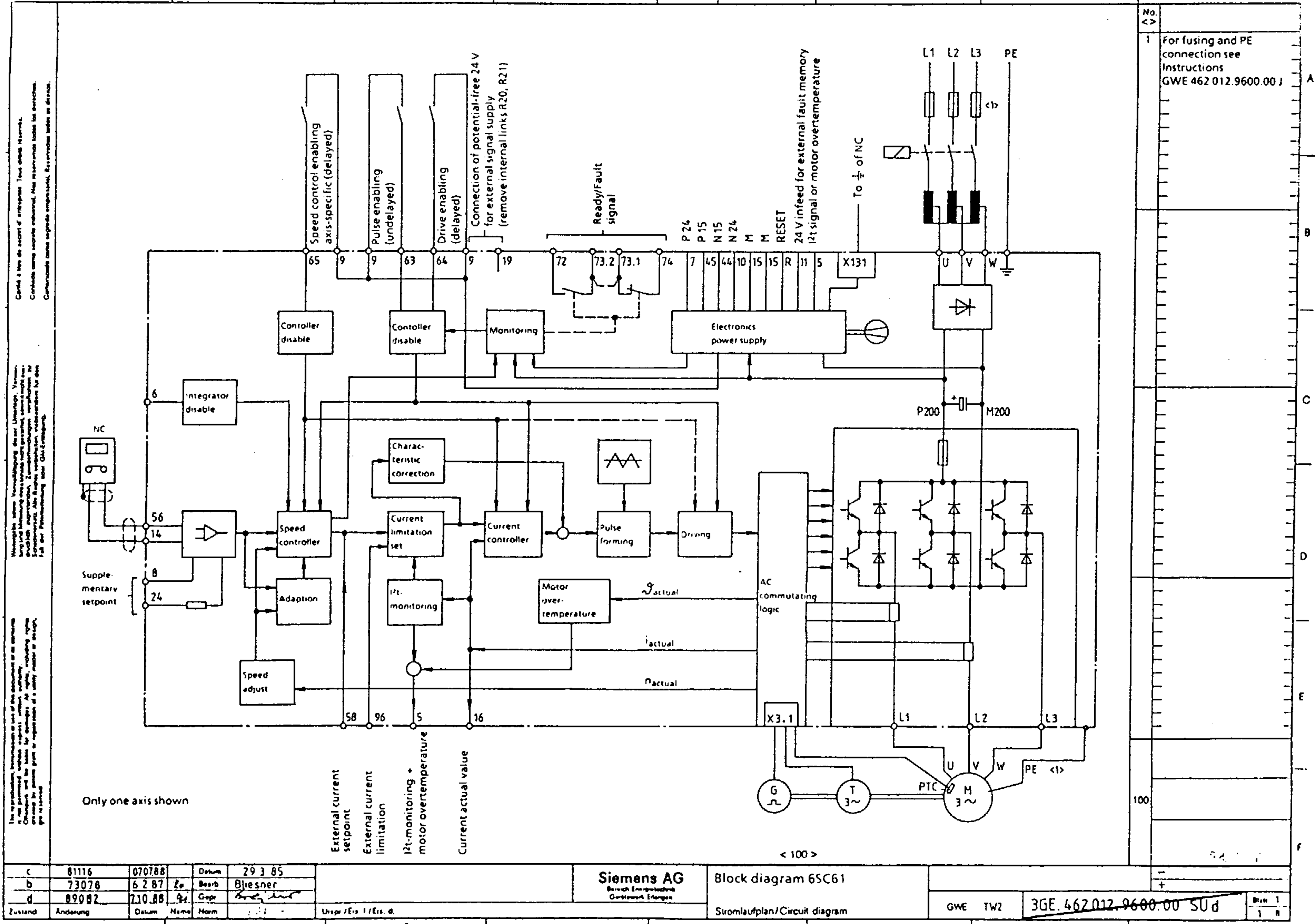

c	81116	070788		Datum	29.3.85	Siemens AG Siemens Energy Services Güterstraße 107 9000 Regensburg	Block diagram 6SC61 Stromlaufplan/Circuit diagram	GWE TWZ 3GE.462.012.9600.00	Blatt 1 1/1
b	73078	6.2.87	Zo	Beerb	Bjesner				
d	89082	7.10.88	Gr	Gepr					
Zustand	Änderung	Datum	Name	Norm		Urspr / Ers 1 / Ers. d.			

5 Block diagram

6 Terminal connection diagram

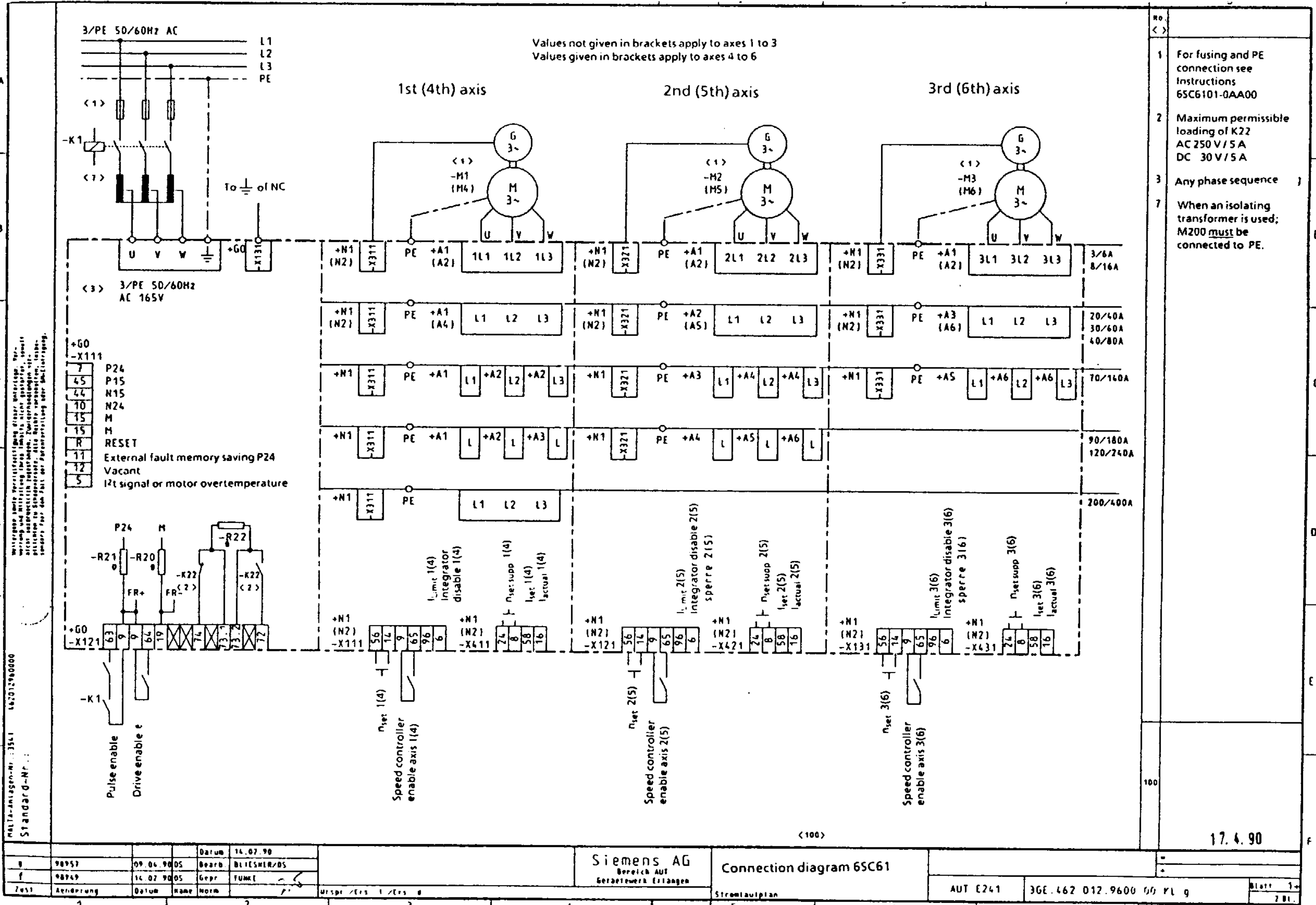

No.	<>
1	For fusing and PE connection see Instructions 6SC6101-0AA00
2	Maximum permissible loading of K22 AC 250 V / 5 A DC 30 V / 5 A
3	Any phase sequence
7	When an isolating transformer is used; M200 must be connected to PE.

Siemens AG		Connection diagram 6SC61		AUT E241		3GE.462 012.9600 60 PL g		Blatt 1-	
Bereich AUT		Gerätewerk Erlangen		Strömungsplan				2 Bl.	

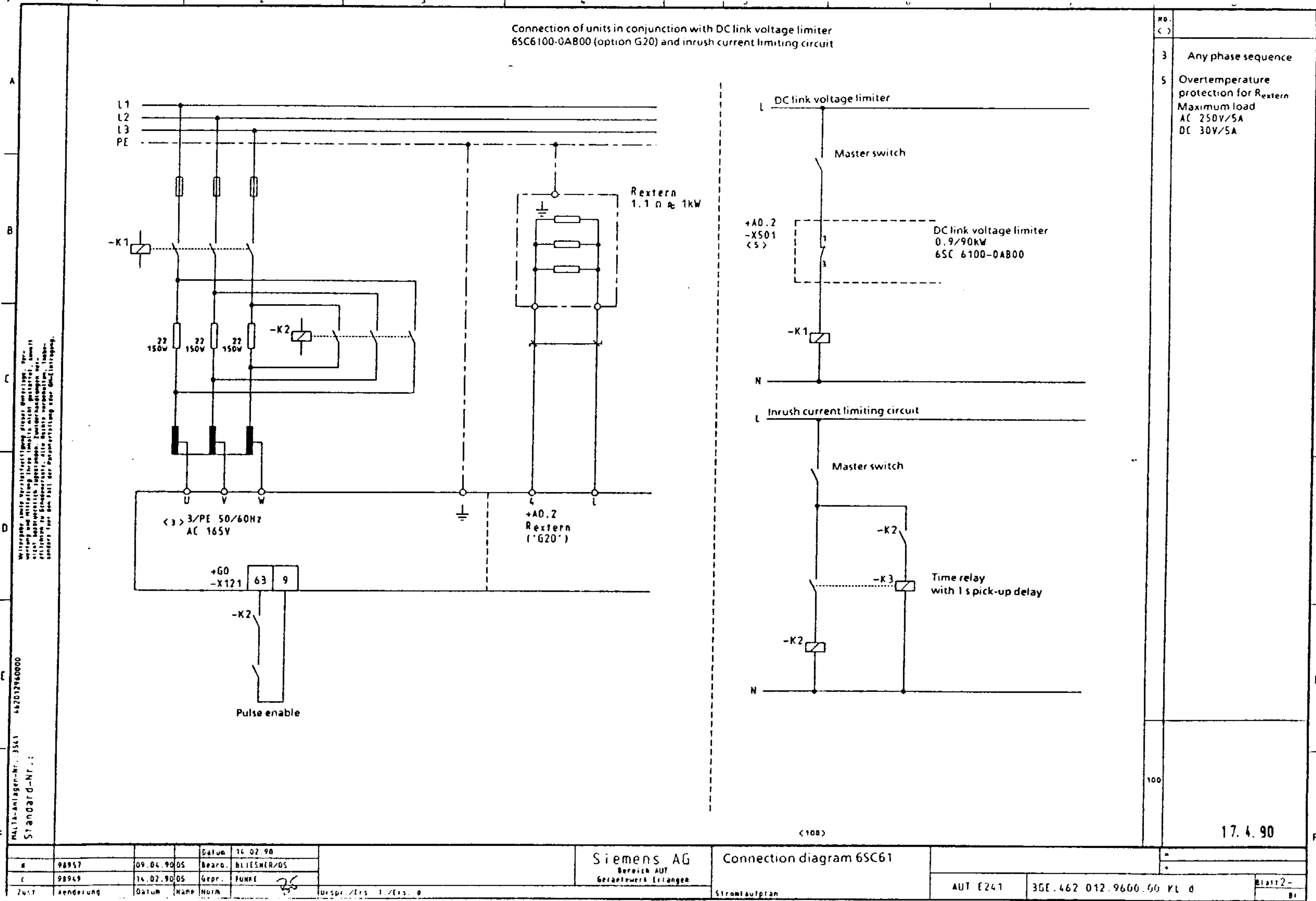

7 Circuit diagram

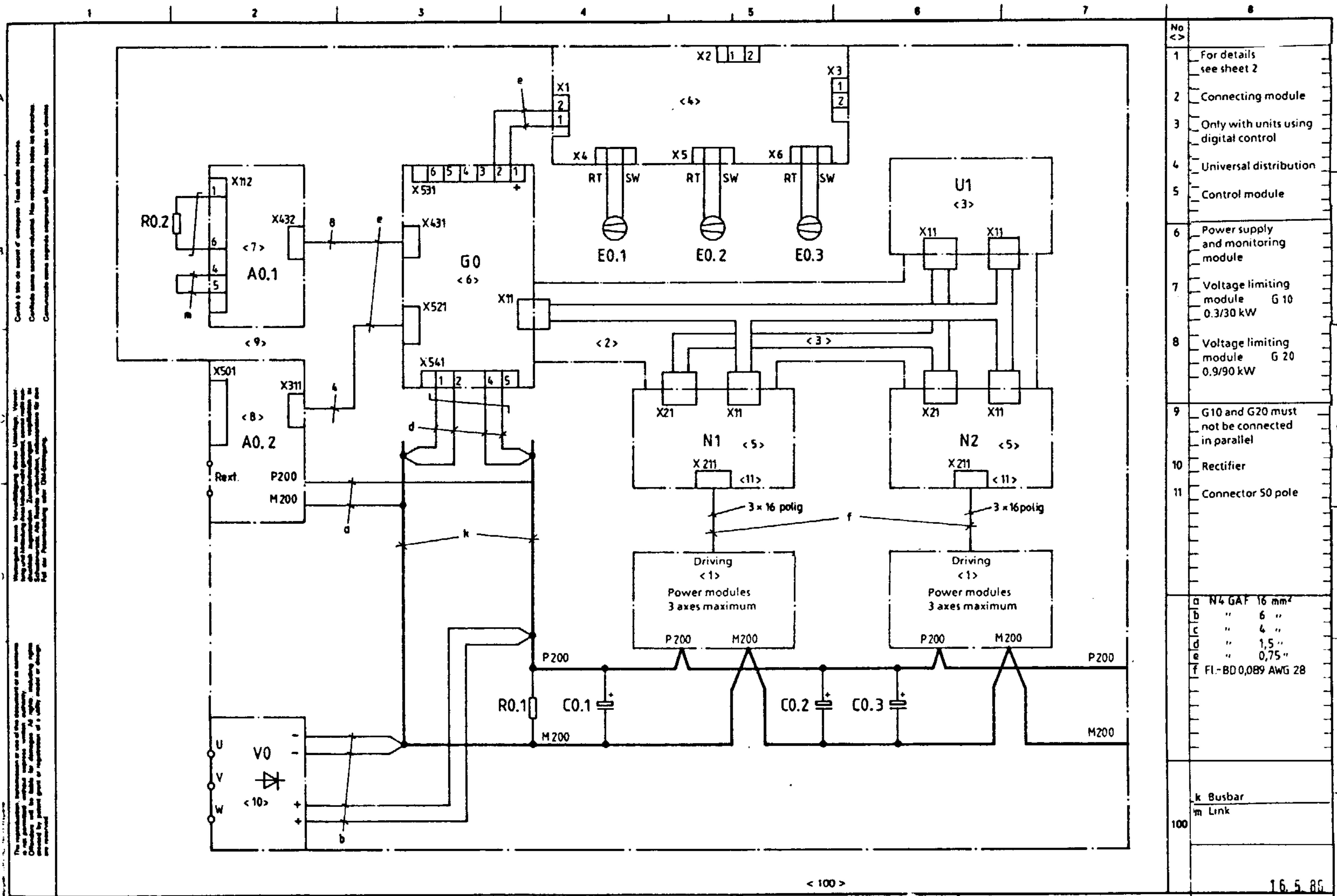

No	<>	
1		For details see sheet 2
2		Connecting module
3		Only with units using digital control
4		Universal distribution
5		Control module
6		Power supply and monitoring module
7		Voltage limiting module G 10 0.3/30 kW
8		Voltage limiting module G 20 0.9/90 kW
9		G10 and G20 must not be connected in parallel
10		Rectifier
11		Connector 50 pole
a		N4 GAF 16 mm ²
b		" 6 "
c		" 4 "
d		" 1,5 "
e		" 0,75 "
f		Fl-BD 0,089 AWG 28
k		Busbar
m		Link
100		
		16.5.86

Datum 3.3.86		Siemens AG		Circuit diagram 6SC61		E 241		3GE.462.012.9600.00 SPd	
Bearb. Bliesner		Siemens AG		Stromlaufplan/Circuit diagram		E 241		3GE.462.012.9600.00 SPd	
Zustand 98950		Ers. 1 462 019 96 00 00 SP				E 241		3GE.462.012.9600.00 SPd	
Änderung						E 241		3GE.462.012.9600.00 SPd	

© Siemens AG 1987 All Rights Reserved 6SC6 101-0AA76
SIMODRIVE 610 (BE)

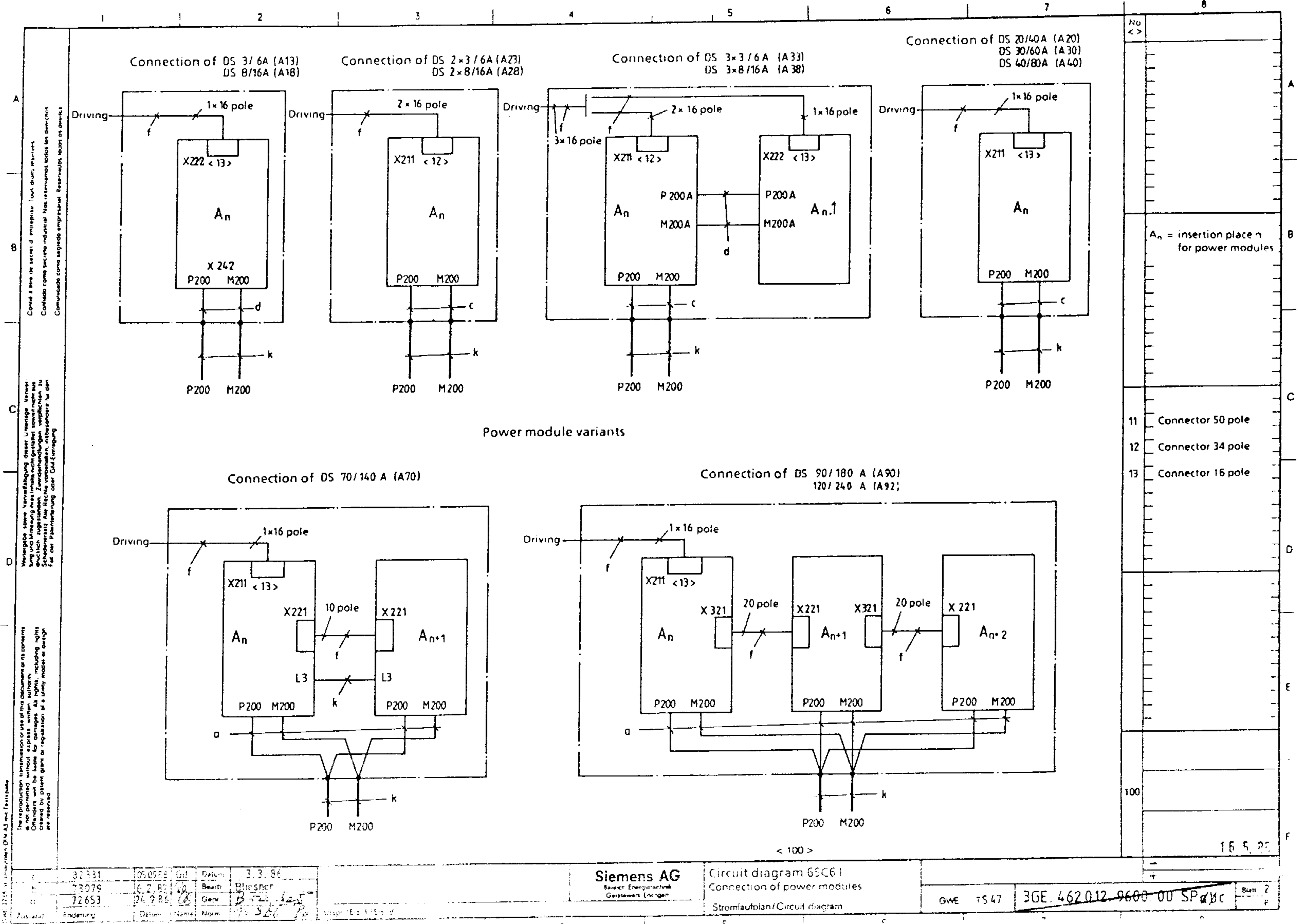

32331	06.09.88	Ed	Datum	3.3.86
33079	16.2.88	Ed	Beard	Blihsner
72653	24.9.85	Ed	Gepr	...
		Datum	Name	Norm

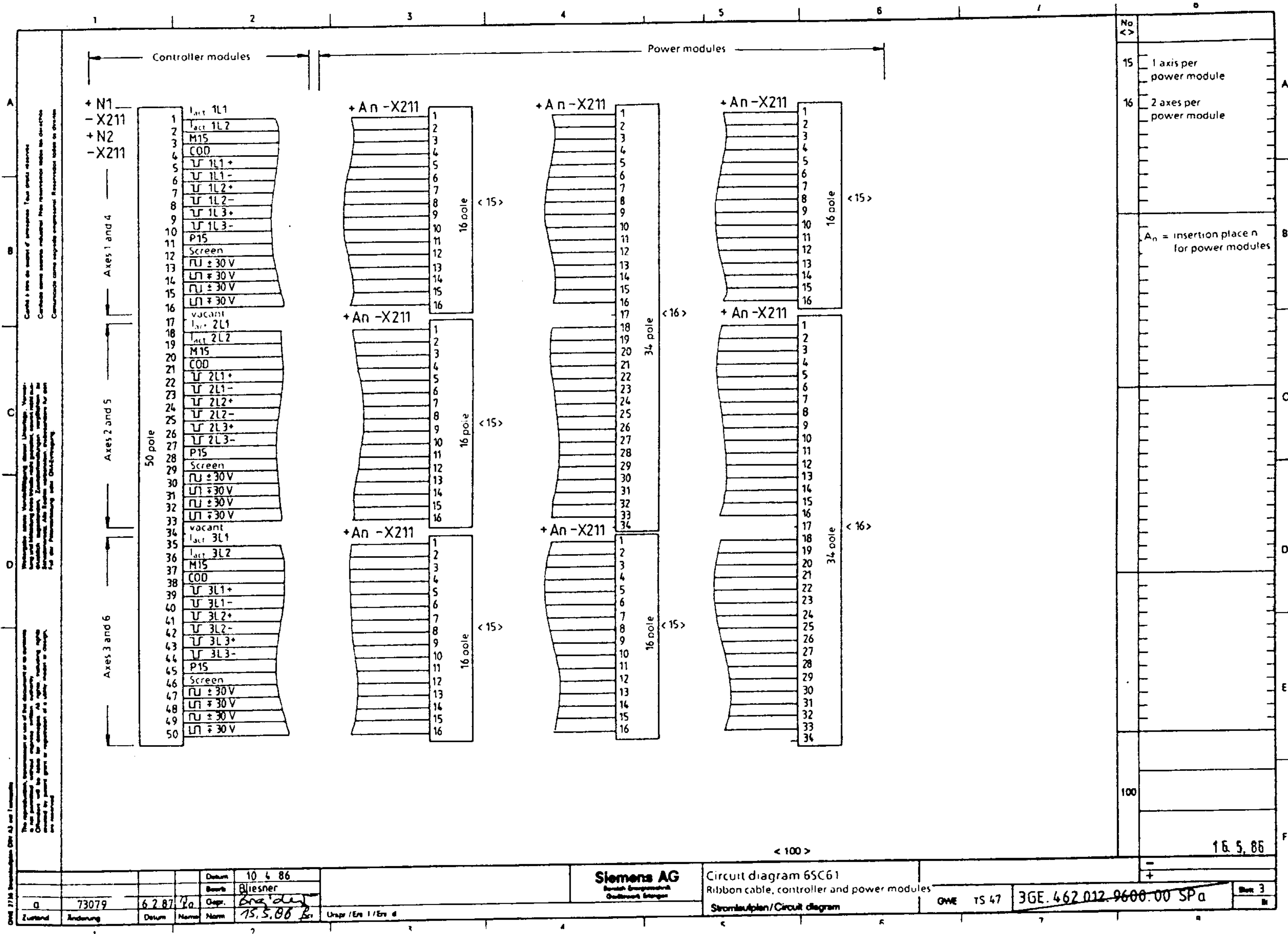

7-3

Zustand		Änderung		Datum		Name		Name		Date		Umspr / Ers 1 / Ers 2		Siemens AG Siemens Energiebereich Quadrant Anlagen		Circuit diagram 6SC61 Ribbon cable, controller and power modules Stromlaufplan/Circuit diagram		GWE 15 47		3GE.462.012-9600.00 SPa		Blatt 3 II	
73079		6.2.87		Ja		Bliesner		Bliesner		75.5.86													

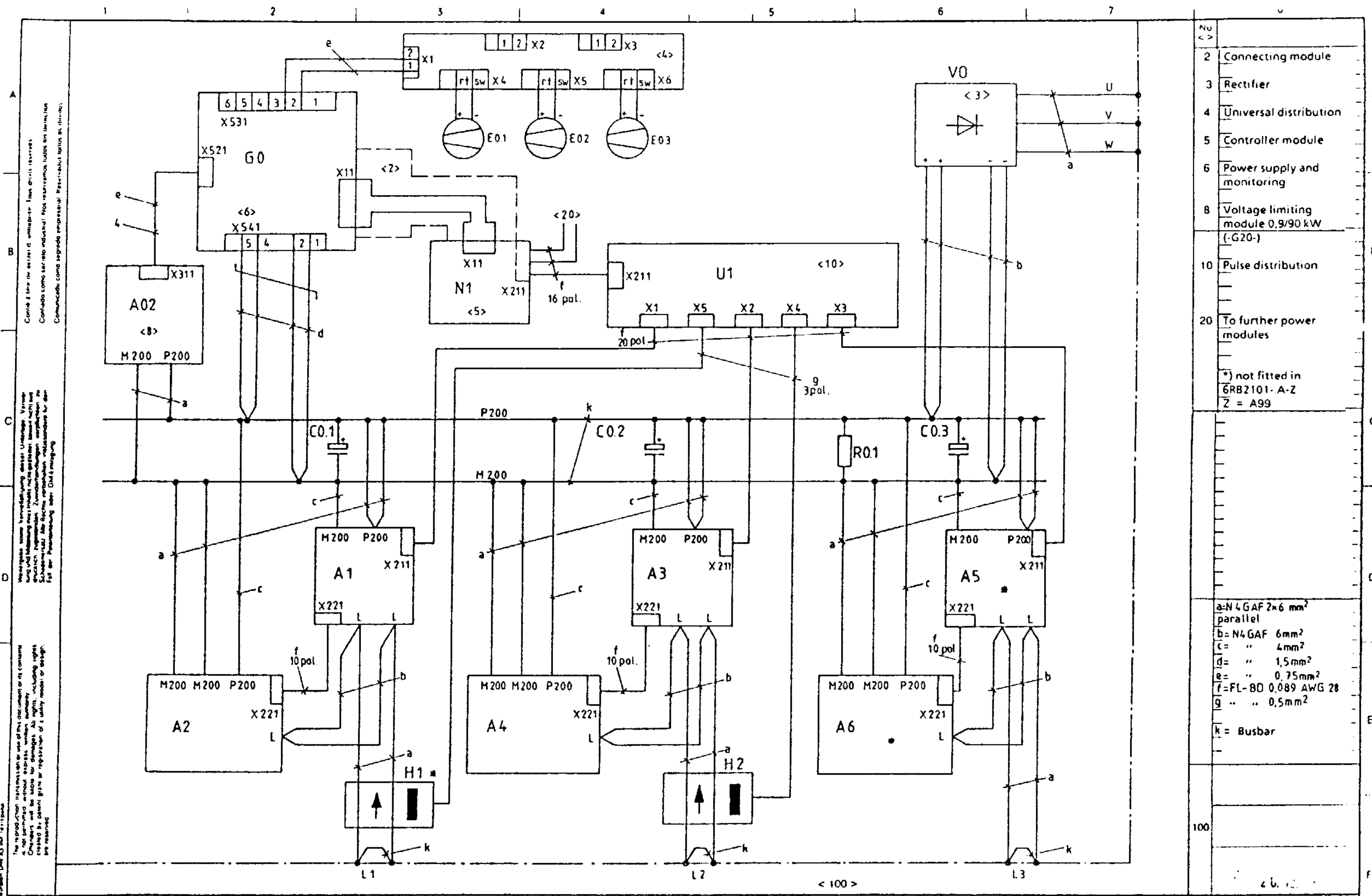

No	<>	
2	<3>	Connecting module
3	<4>	Rectifier
4	<5>	Universal distribution
5	<6>	Controller module
6	<7>	Power supply and monitoring
8	<8>	Voltage limiting module 0,9/90 kW (-G20-)
10	<9>	Pulse distribution
20	<10>	To further power modules

*) not fitted in 6RB2101-A-Z
Z = A99

a	= N 4 GAF 2x6 mm ² parallel
b	= N 4 GAF 6mm ²
c	= " 4mm ²
d	= " 1,5mm ²
e	= " 0,75mm ²
f	= FL-BD 0,089 AWG 28
g	= " 0,5mm ²
k	= Busbar

b 95734 31190 Bi		Datum 07.12.88		Siemens AG		6 SC 6101-, B-Z AC 200/400A		GWE TW 2		3 GE. 4.62 019 9050.80 SP p/b	
a 99221 21289 Ru		Bearb Bliesner/Ru		Siemens AG		6 RB 2101-, A-Z DC 150/300A		Z = A99		Hann	
Zustand		Anderung		Datum		Name		Norm		Urspr / Ers I / Ers d	
										Stromlaufplan/Circuit diagram	

7-4

© Siemens AG 1987 All Rights Reserved 6SC6 101-0AA76 SIMODRIVE 610 (BE)

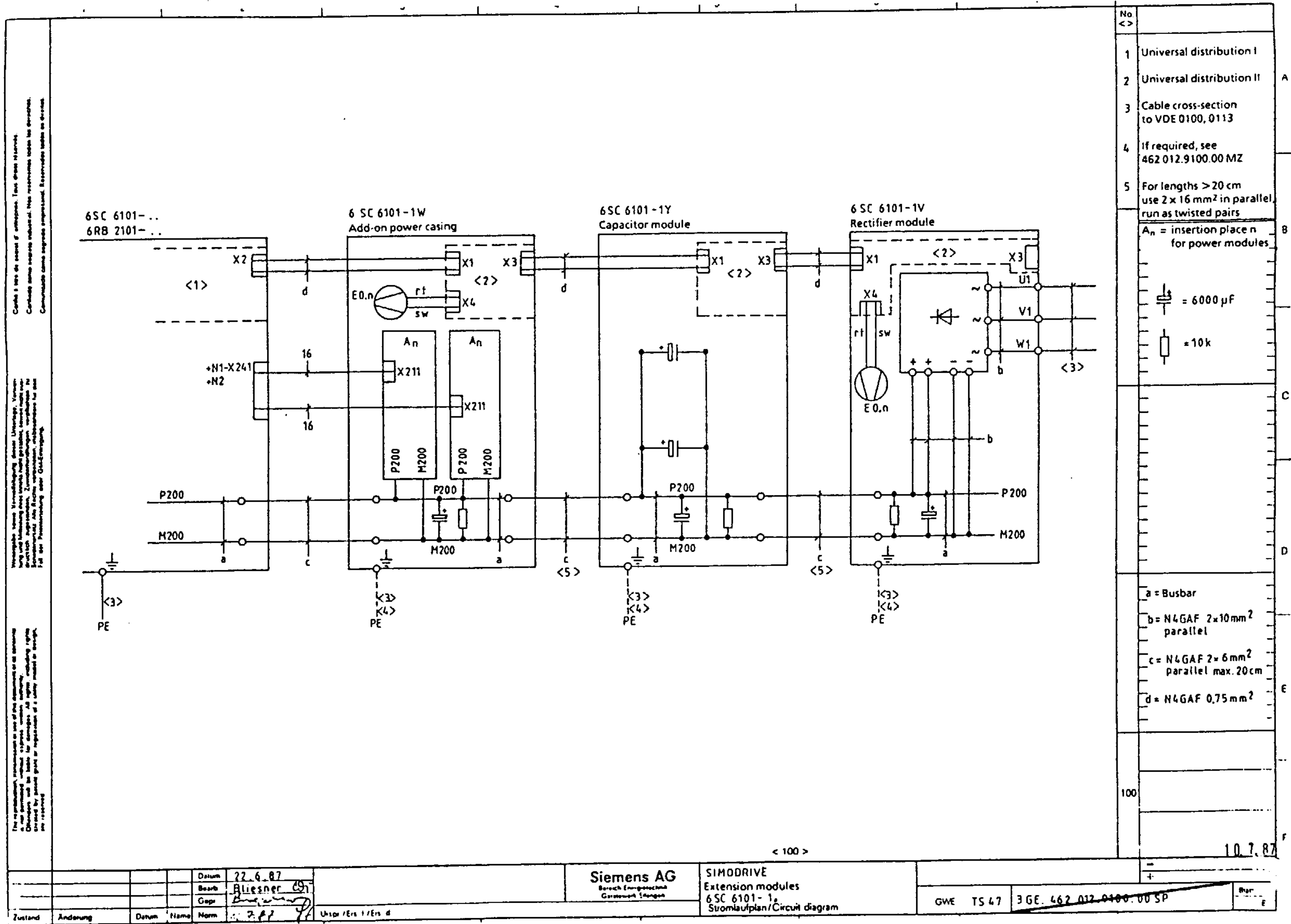

8 Wiring of different power module variants

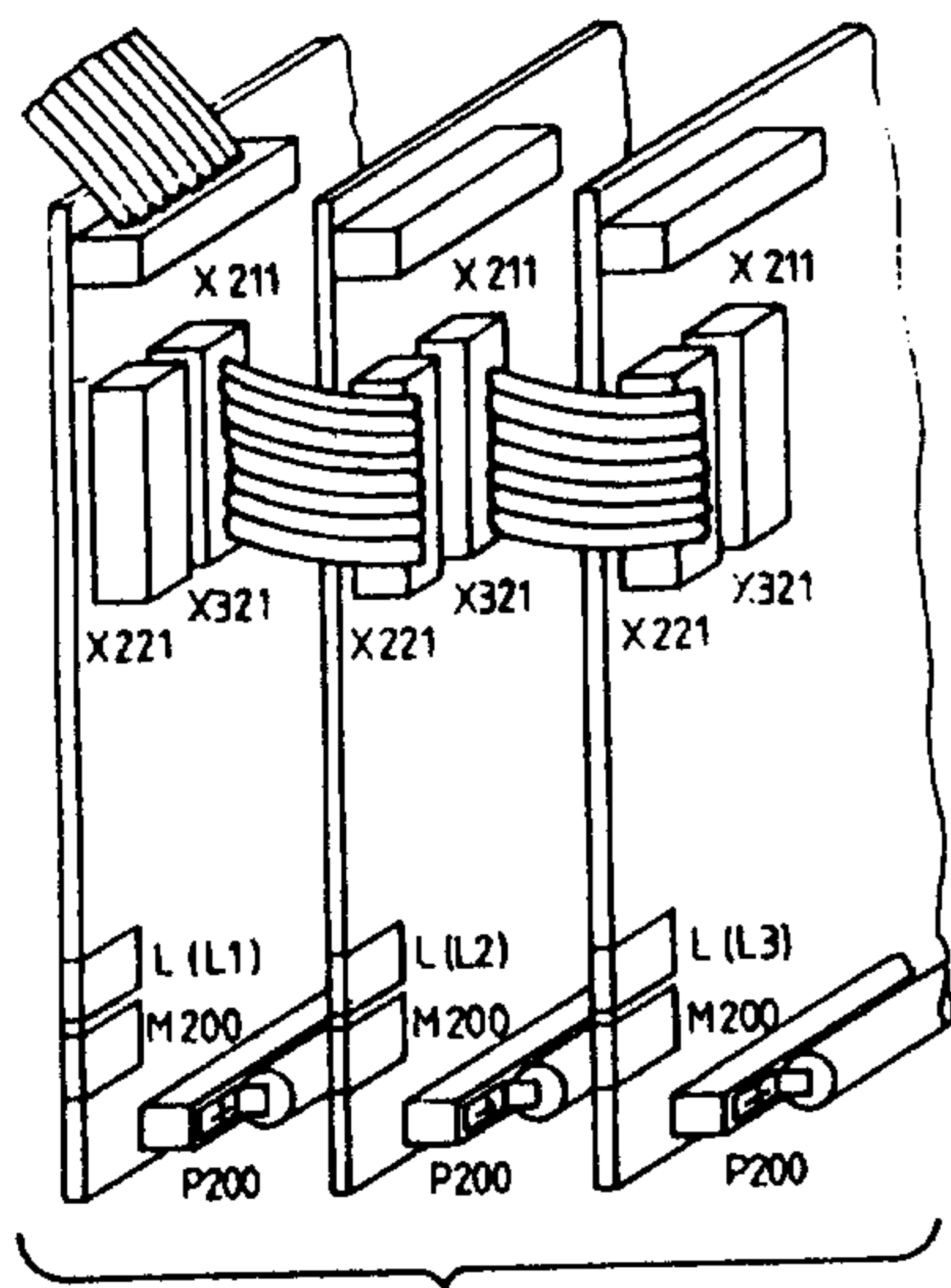

1 x 90 / 180 A
1 x 120 / 240 A

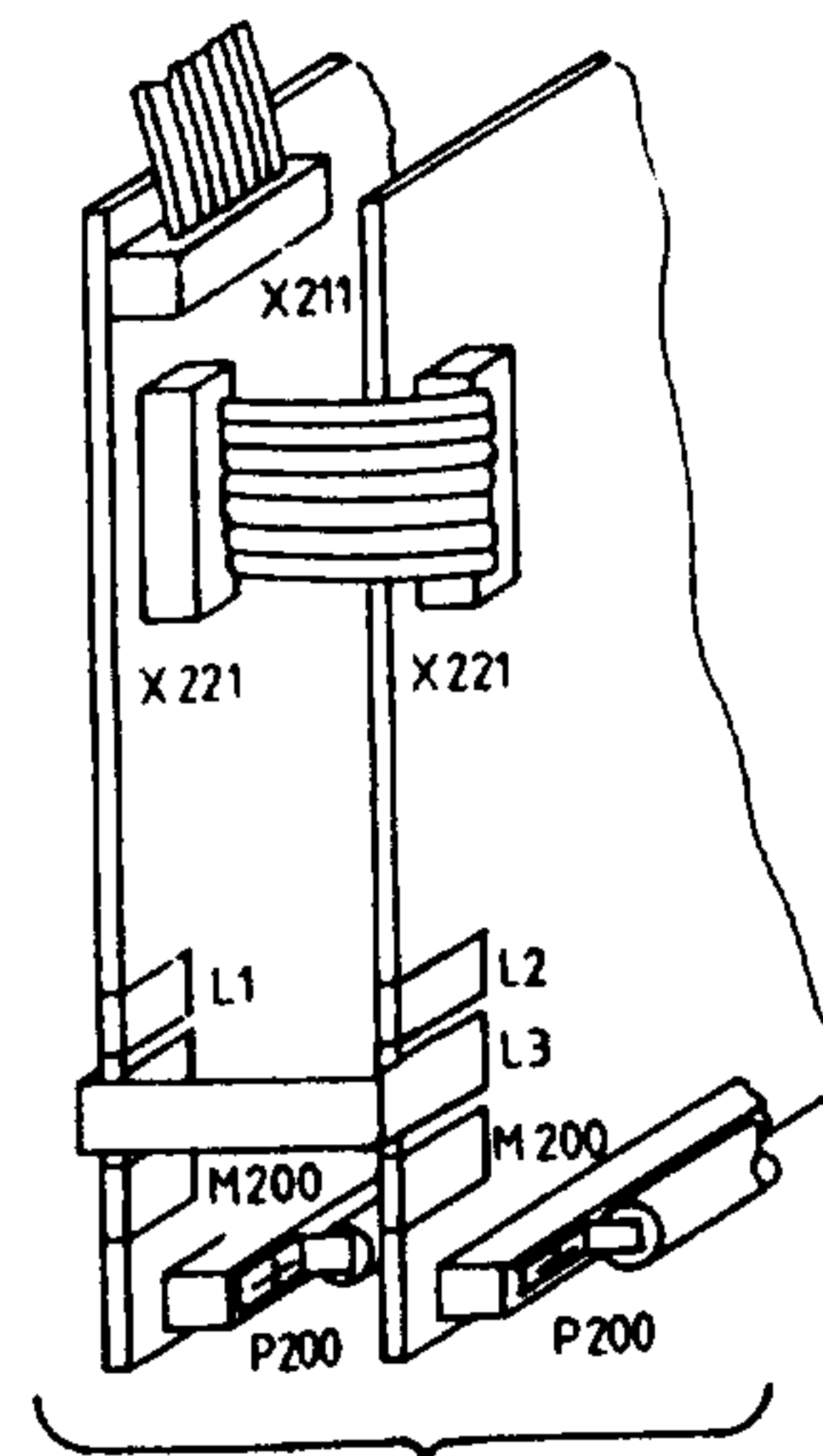

1 x 70 / 140 A

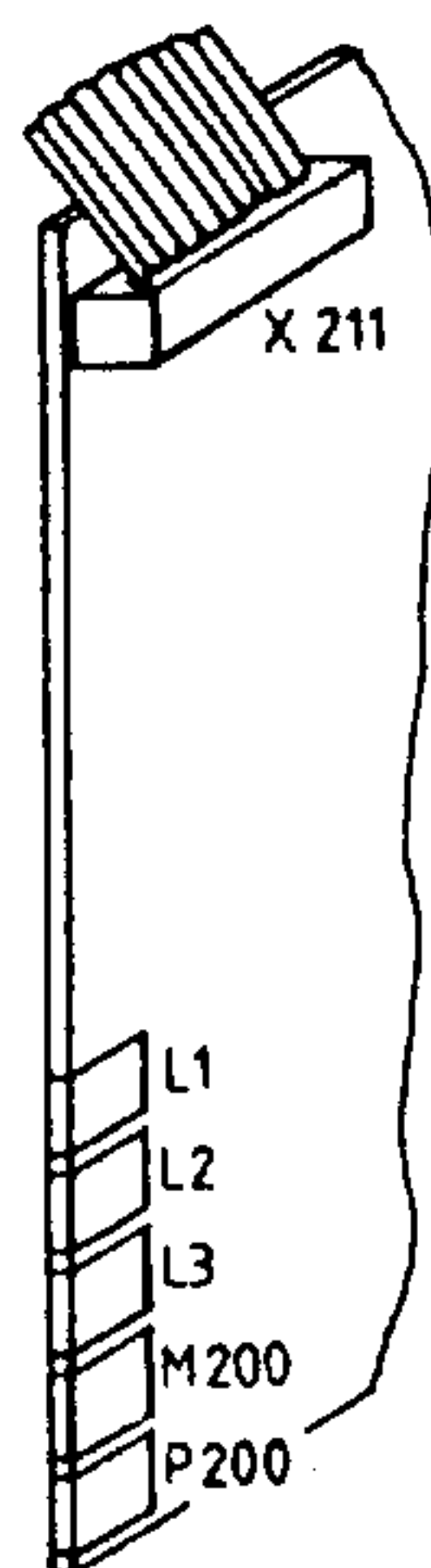

1 x 20 / 40 A
1 x 30 / 60 A
1 x 40 / 80 A

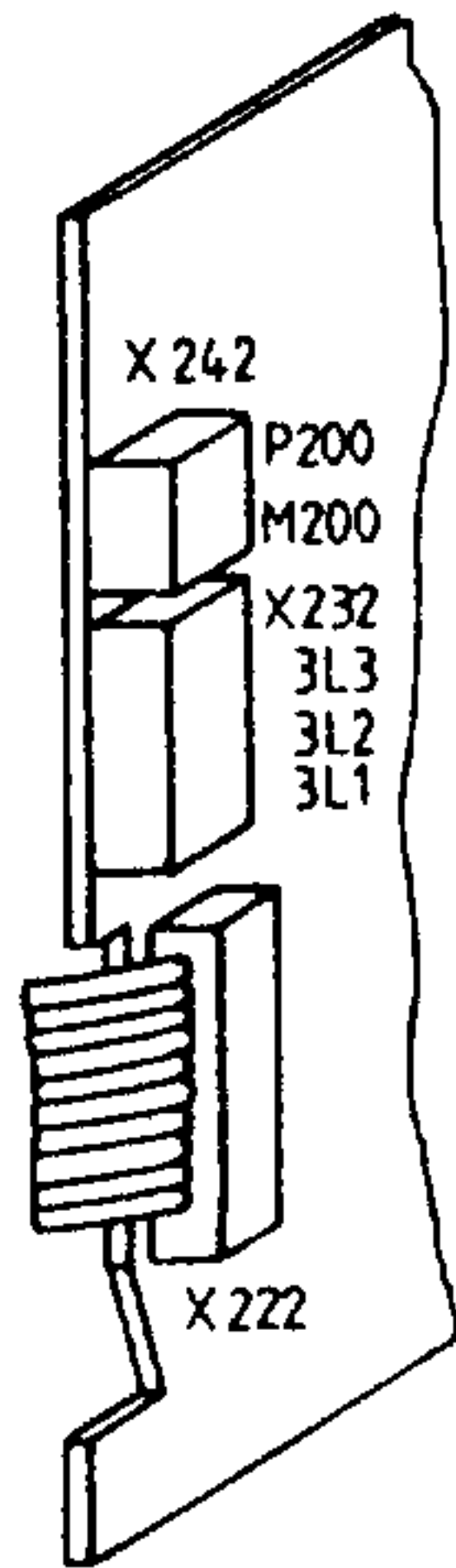

1 x 3 / 6 A
1 x 8 / 16 A

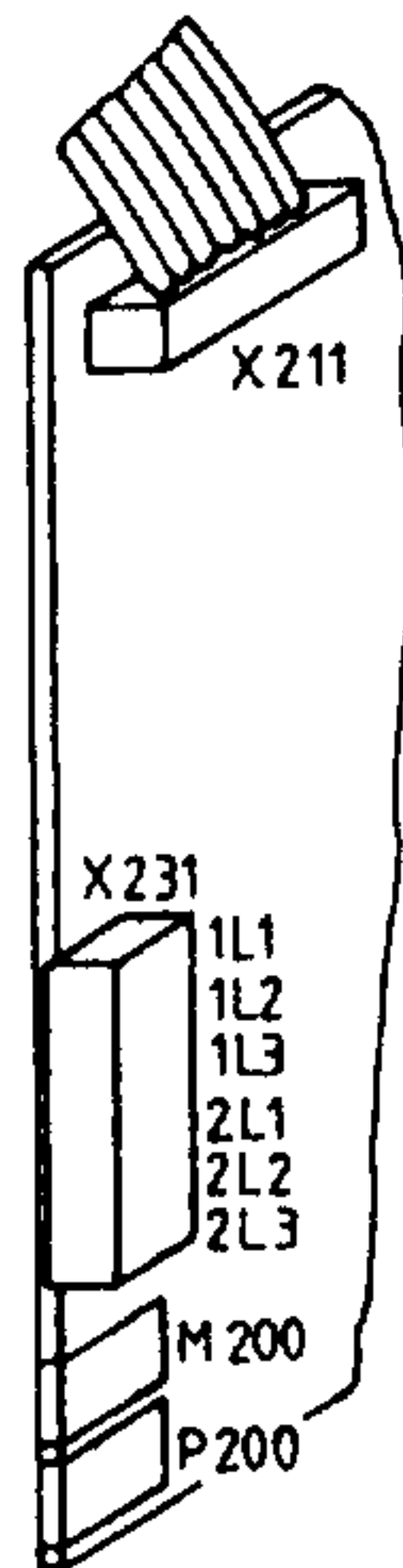

2 x 3 / 6 A
2 x 8 / 16 A

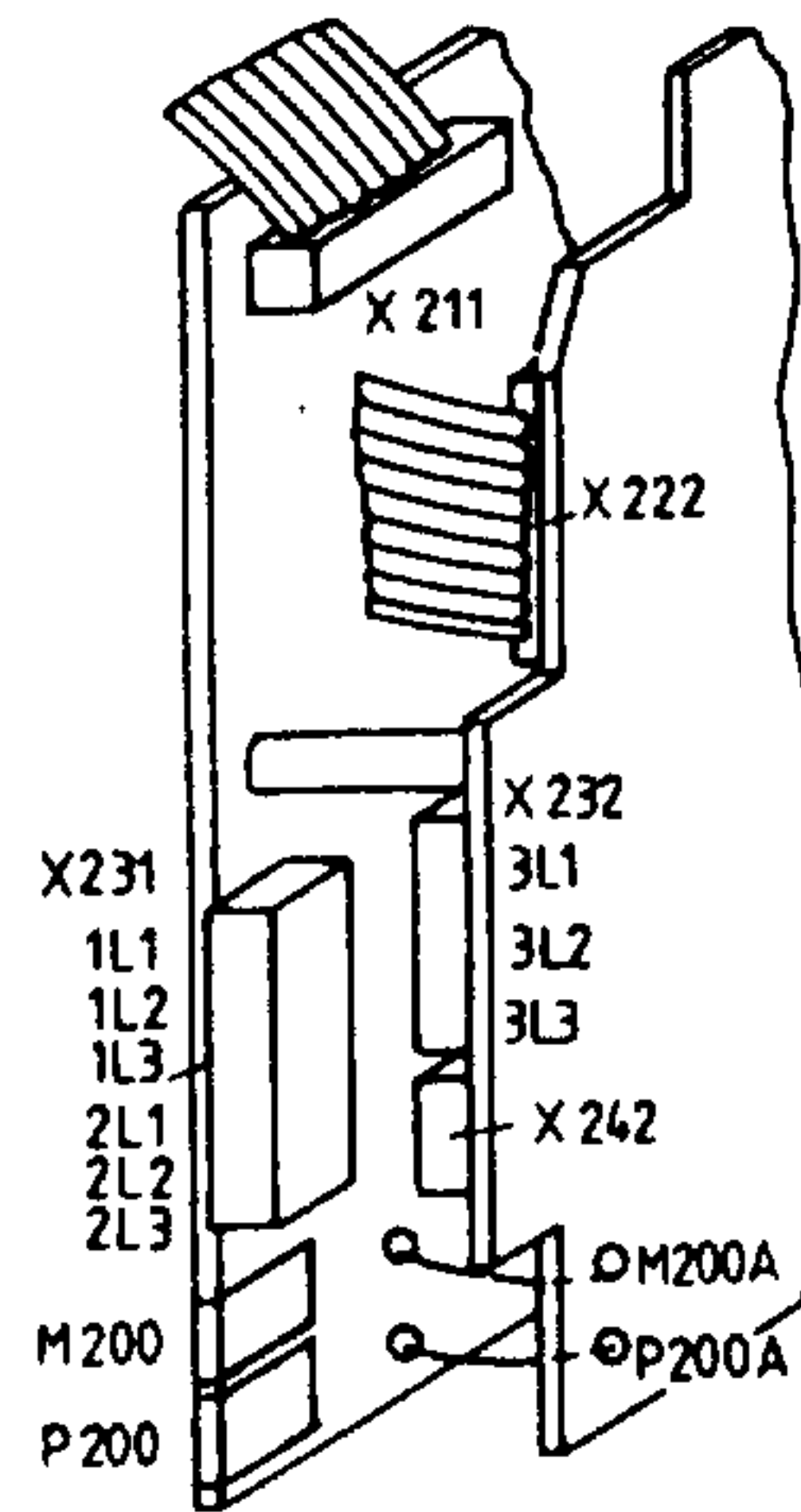

3 x 3 / 6 A
3 x 8 / 16 A

9 Dimension drawings

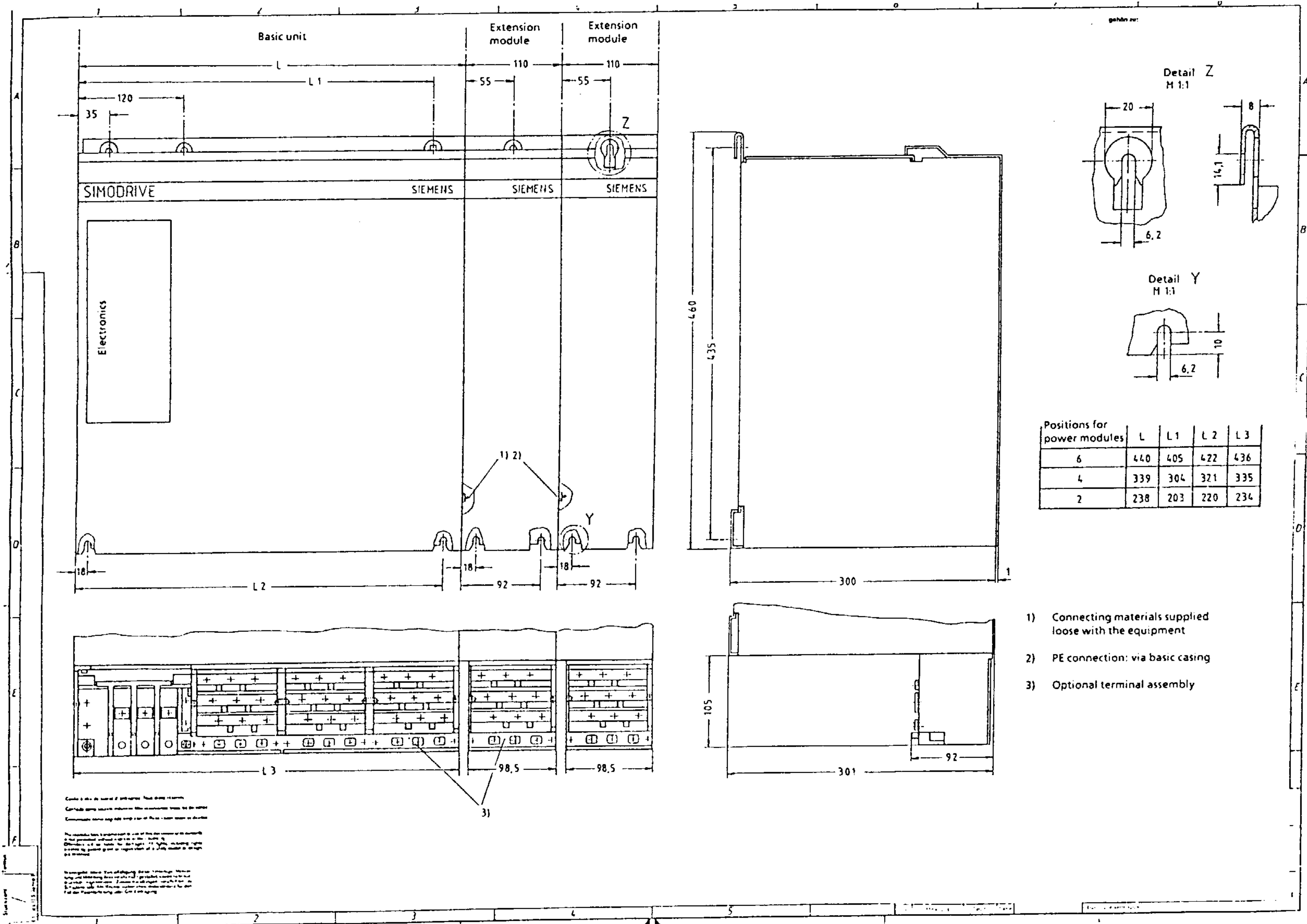

10 Setting elements

Proportional gain of the current controller

Switches S1/ to S3/ must be set to ON	-	6	7	6	8	6	7	9	6	6	7	6	8	7	6
				+		+	+		+	+	+	+	+	+	+
				7		8	8		7	9	9	7	9	8	7
								+			+			+	+
								8			9			9	8
															+
															9
$K_p(I)$	0,5	1	2	2,5	4	4,5	5,5	6	6	6,5	7,5	8	9,5	11	11,5

Current limit

Switches S1/ to S3/ must be set to ON	-	2	3	2	4	2	3	2	5	2	3	2	4	3	2
				+		+	+	+		+	+	+	+	+	+
				3		4	4			5	5		5	4	3
								+						+	+
								4						5	4
															+
															5
$\frac{I_{MAX}}{I_{LIM}} [\%]$	100	85	68	61	50	46	41	39	36	34	30	29	26	24	23

Speed controller gain

$K_p(n) = 3,5$ $K_p(n) = 4,9$

Reset time of speed controller

$T_N(n) = 39ms$ $T_N(n) = 2,7ms$

Tacho adjustment

$n = 2,2 \cdot n_{rated}$ $n = 0,7 \cdot n_{rated}$

Switchover to current control

S1.10	OFF	ON
Operation	n-controlled	I-controlled

Reversal

S1.1	OFF	ON
$SGN \frac{n_{act.}}{n_{set}}$		

Notes on electrostatic charges

Electrostatically sensitive devices (ESD)

Generally, PCBs should not be touched unless work has to be carried out on them.

Before touching a PCB, the person carrying out the work must himself be electrostatically discharged. The simplest way of doing this is to touch an electrically conducting earthed object (e.g. a bare metal part of a switchboard or the protective earth contact of a socket outlet).

PCBs must not be allowed to come in contact with electrically insulating materials such as plastic foil, insulating table tops or clothing made of synthetic fibres.

PCBs may only be set down or stored on electrically conducting surfaces.

When carrying out soldering jobs on PCBs, make sure that the soldering tip has been earthed.

PCBs and electronic components should generally be packed in electrically conducting containers (such as metallized-plastic boxes or metal cans) before being stored or shipped.

If the use of non-conducting packing containers cannot be avoided, PCBs must be wrapped in a conducting material before being put in them. Examples of such materials include electrically conducting foam rubber or household aluminium foil.

For easy reference, the protective measures necessary when dealing with sensitive electronic components are illustrated in the sketches below.

a = Conductive flooring
b = Anti-static table
c = Anti-static footwear

d = Anti-static overall
e = Anti-static chain
f = Earthing connections of cabinets

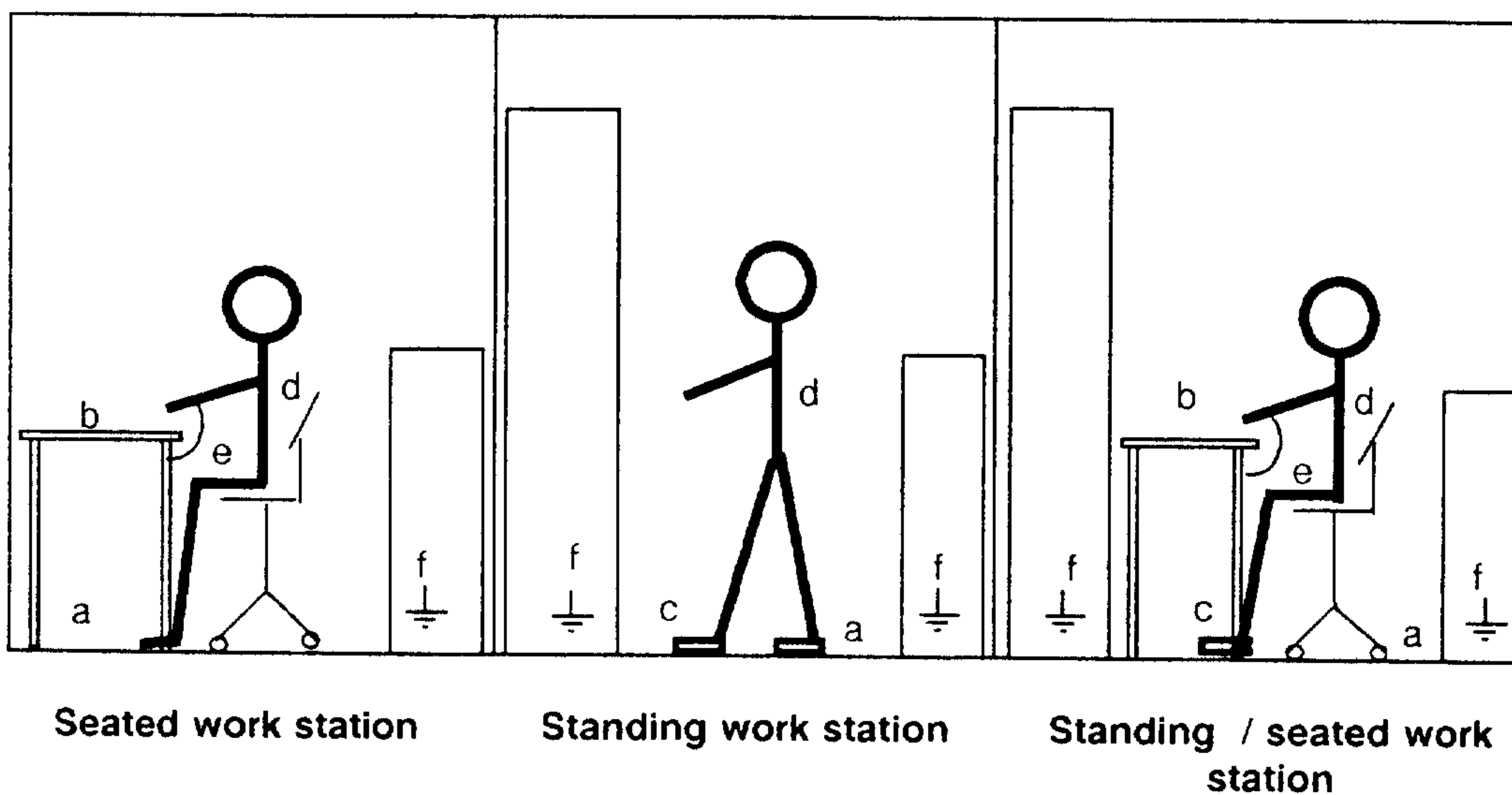

Addresses

Messrs. Euchner
Kohlhammerstr. 16
D-7022 Leinfelden-Echterdingen 1

Du Pont de Nemours GmbH
Max-Planck-Str. 11
D-6057 Dietzenbach

Messrs. Kabelmetall Electro
Postfach 25 51
D-8500 Nürnberg 1

Standards and specifications

DIN 40050	IP Degrees of protection
DIN 46234	Cable lugs
DIN VDE 0100	Specifications for the installation of power-current systems with operating voltages of up to 1000 V
DIN VDE 0106	Protection against electric shock
DIN VDE 0113	Electrical equipment for industrial machines
DIN VDE 0558	VDE specifications for semiconductor converters

Available from:	DIN standards	DIN VDE specifications
	Beuth-Verlag GmbH Postfach 1145 D-1000 Berlin 30	VDE-Auslieferungsstelle Merianstraße 29 D-6050 Offenbach

Setting data

Serial No.:

Power module	Servo motor					Current limit					Current controller						
	Axis	1FT	M _o in Nm	I _o in A	n _{rated} in min ⁻¹	Contacts of DIL-switches S1, S2, S3					I _{max} in A	Contacts of DIL-switches S1, S2, S3				Kp (l)	
						1	2	3	4	5		6	7	8	9		

Setting of potentiometers:

	Tacho	Kp(n)	T _N (n)			Tacho	Kp(n)	T _N (n)			Tacho	Kp(n)	T _N (n)
Axis 1					Axis 2						Axis 3		
Axis 4					Axis 5						Axis 6		

Jumpers for matching the tacho voltage

	X20	X21	X22			X23	X24	X25			X26	X27	X28
Axis 1					Axis 2						Axis 3		
Axis 4					Axis 5						Axis 6		

Speed controller adaption

	R15	R94			R46	R97			R77	R100
Axis 1				Axis 2				Axis 3		
Axis 4				Axis 5				Axis 6		

Electrical weight compensation

	R3	R5			R32	R36			R63	R67
Axis 1				Axis 2				Axis 3		
Axis 4				Axis 5				Axis 6		

Speed setpoint channel

	C301	R450			C302	R461			C303	R471
Axis 1				Axis 2				Axis 3		
Axis 4				Axis 5				Axis 6		

Monitoring circuit "speed controller at the stop"

	R605			R646		.	R656
Axis 1			Axis 2			Axis 3	
Axis 4			Axis 5			Axis 6	

Machine-dependent values

		Axis 1 (X)	Axis 2 (Y)	Axis 3 (Z)	Axis 4 (U)	Axis 5 (V)	Axis 6 (W)
Setpoint	at V_{max} .						
Tacho voltage	at V_{max} .						
Motor speed	at V_{max} .						

Miscellaneous:

Date:

Commissioning engineer:

To
Siemens AG

AUT E234
Postfach 4848
W-8500 Nürnberg 1

Suggestions

Corrections

concerning booklet:

SIMODRIVE 610
Transistor PWM Inverter for Three-Phase
Feed Drives with Analog Control

Manufacturer-Documentation

Sender

Name _____

Firm/Department _____

Address: _____

Telephone: _____ / _____

Instruction Manual

Order-No.: 6SC6101-0AA76
(GWE 462 012.9600.76 Jb-101)

Edition: 08.91

If you have discovered any printing errors when reading this document, please send us details using this printed form. We would also be very grateful for any ideas and suggestions for improvement.

Suggestions and/or corrections

Published by Siemens AG
Automation Group
Automation Systems for
Machine Tools, Robots, and
Special-Purpose Machines
Postfach 48 48, W-8500 Nürnberg 1
Federal Republic of Germany

© Siemens AG 1987 All Rights Reserved
Subject to change without prior notice

Siemens Aktiengesellschaft

Order No.: 6SC6101-0AA76
Printed in the Fed. Rep. of Germany
11911.5 GWE 462 012.9600.76 Jb-101

