

SIEMENS

SINAMICS

SINAMICS S120

Grid infeed

System Manual

Edition

04/2015

Answers for industry.

SIEMENS

SINAMICS

S120 Grid infeed

System Manual

<u>Preface</u>	
<u>Fundamental safety instructions</u>	1
<u>General information</u>	2
<u>Grid types</u>	3
<u>Standards and directives</u>	4
<u>Function modules</u>	5
<u>Detailed descriptions of the function modules</u>	6
<u>Commissioning</u>	7
<u>Device overview</u>	8
<u>Function diagrams</u>	9
<u>Appendix</u>	A

Valid for: Firmware Version 4.7



04/2015

A5E03347436A

Legal information

Warning notice system

This manual contains notices you have to observe in order to ensure your personal safety, as well as to prevent damage to property. The notices referring to your personal safety are highlighted in the manual by a safety alert symbol, notices referring only to property damage have no safety alert symbol. These notices shown below are graded according to the degree of danger.

 DANGER
indicates that death or severe personal injury will result if proper precautions are not taken.
 WARNING
indicates that death or severe personal injury may result if proper precautions are not taken.
 CAUTION
indicates that minor personal injury can result if proper precautions are not taken.
NOTICE
indicates that property damage can result if proper precautions are not taken.

If more than one degree of danger is present, the warning notice representing the highest degree of danger will be used. A notice warning of injury to persons with a safety alert symbol may also include a warning relating to property damage.

Qualified Personnel

The product/system described in this documentation may be operated only by **personnel qualified** for the specific task in accordance with the relevant documentation, in particular its warning notices and safety instructions. Qualified personnel are those who, based on their training and experience, are capable of identifying risks and avoiding potential hazards when working with these products/systems.

Proper use of Siemens products

Note the following:

 WARNING
Siemens products may only be used for the applications described in the catalog and in the relevant technical documentation. If products and components from other manufacturers are used, these must be recommended or approved by Siemens. Proper transport, storage, installation, assembly, commissioning, operation and maintenance are required to ensure that the products operate safely and without any problems. The permissible ambient conditions must be complied with. The information in the relevant documentation must be observed.

Trademarks

All names identified by ® are registered trademarks of Siemens AG. The remaining trademarks in this publication may be trademarks whose use by third parties for their own purposes could violate the rights of the owner.

Disclaimer of Liability

We have reviewed the contents of this publication to ensure consistency with the hardware and software described. Since variance cannot be precluded entirely, we cannot guarantee full consistency. However, the information in this publication is reviewed regularly and any necessary corrections are included in subsequent editions.

Preface

Objective

This document describes SINAMICS units and functions which enable power to be fed into a power grid or to an island grid. Reference is made only to the hardware components required for infeed and the necessary software functions/options. In some instances, the hardware differs from the conventional, widely used SINAMICS infeed and regenerative feedback units for industrial applications. The software offers options to provide additional functionality.

Detailed information on general hardware, software functions and engineering information/instructions are described in separate documentation and can be obtained from the regional SIEMENS office and used as supplementary information for this documentation.

Target group

This document is used by system integrators and Original Equipment Manufacturers (OEMs) to operate, parameterize and commission the SINAMICS devices with the associated software functions for power infeed.

Validity

The document applies to the following devices:

- Active Line Modules, booksize format with article number ... AA3
- Active Line Modules, chassis format with article number ... AA4

Further reference documents

- SINAMICS S120/S150 List Manual
- SINAMICS S120 Commissioning Manual
- SINAMICS S120 Function Manual Drive Functions
- SINAMICS S120 Equipment Manual for Chassis Power Units
- SINAMICS S120 Equipment Manual for Booksize Power Units
- SINAMICS LV Configuration Manual

Internet address

Up-to-date information about our products can be found on the Internet at:
<http://www.siemens.com> (<http://www.siemens.com>)

You can find information on SINAMICS at: www.siemens.com/sinamics
(www.siemens.com/sinamics)

Application descriptions can be found at: Application and tools
(<https://support.industry.siemens.com/cs/ww/en/ps/ae>)

Technical support

European and African time zones	
Telephone	+49 (0) 911 895 7222
Fax	+49 (0) 911 895 7223
Internet	http://www.siemens.com/automation/support-request

America time zones	
Telephone	+1 423 262 2522
Fax	+1 423 262 2200
Internet	techsupport.sea@siemens.com

Asia/Pacific time zones	
Telephone	+86 1064 757 575
Fax	+86 1064 747 474
Internet	support.asia.automation@siemens.com

Note

For technical support telephone numbers for different countries, go to:

<http://www.automation.siemens.com/partners>

EC Declarations of Conformity

The EC Declaration of Conformity for the EMC Directive and for the Low Voltage Directive can be found/obtained from the relevant regional office of the DF MC or PD LD Business Units of Siemens AG.

Table of contents

	Preface	5
1	Fundamental safety instructions	11
1.1	General safety instructions	11
1.2	Safety instructions for electromagnetic fields (EMF)	14
1.3	Handling electrostatic sensitive devices (ESD)	15
1.4	Industrial security	16
1.5	Residual risks of power drive systems	17
2	General information	19
3	Grid types	21
3.1	Power grid	21
3.2	Island grid	23
3.3	Microgrid	24
4	Standards and directives	25
4.1	Protection and safety	25
4.2	EMC	25
4.3	Grid harmonics	25
4.4	Grid codes/standards	26
4.5	Standards for Germany, Italy, USA	26
5	Function modules	29
5.1	Overview	29
5.2	Typical applications of grid infeed to generate power	33
5.3	Description of the function modules	34
5.3.1	Line transformer function module	34
5.3.1.1	Grid-friendly transformer magnetization	34
5.3.1.2	Identification of the transformer data	35
5.3.1.3	Line filter and transformer monitoring	35
5.3.2	Function module for grid droop control	35
5.3.2.1	Black start in an island grid	39
5.3.2.2	Synchronizing an island grid to an external power grid	39
5.3.3	Function module, dynamic grid support	40
5.3.3.1	Dynamic grid support	40
5.3.3.2	Grid monitoring anti-islanding	43
5.3.3.3	Voltage-time monitoring	44
5.3.3.4	Frequency-time monitoring	44
5.3.3.5	Other monitoring functions that can be activated	45
5.3.4	Cosinus phi display function module	45

5.3.5	Additional closed-loop controls function module.....	47
5.3.5.1	Reactive current/apparent current limits	47
6	Detailed descriptions of the function modules.....	49
6.1	Additional closed-loop controls for current-controlled operation.....	49
6.1.1	Background information	49
6.1.2	Dynamic grid support.....	50
6.1.3	DC component controller	52
6.1.4	Negative sequence system current controller.....	53
6.1.5	Grid-friendly transformer magnetization	54
6.2	Controls for grid droop operation	55
6.2.1	Background information	55
6.2.2	U-f droop control	59
6.2.3	Damping power oscillations	62
6.2.4	DC component controller	63
6.3	Supplementary functions	63
6.3.1	Grid voltage sensing using an additional VSM10	63
6.3.2	Transformer model and identification	64
6.4	Back-to-back operation of Active Line Modules.....	65
7	Commissioning	67
7.1	Safety notices.....	67
7.2	Preconditions	68
7.3	Basic commissioning	69
7.3.1	Infeed units in the chassis format	69
7.3.2	Infeed units in the booksize format	69
7.4	Commissioning example for an infeed with voltage and frequency control for an island grid.....	70
7.4.1	Design	70
7.4.2	General information	71
7.4.3	Function modules for creating a line infeed in an island grid.....	72
7.4.4	Creating an additional VSM10	72
7.4.5	Adapting the topology and the VSM10 assignments	73
7.4.6	Performing additional parameter settings in the expert list.....	74
7.4.7	Signal interfaces.....	83
7.5	Commissioning example of an infeed with dynamic grid support for a power grid.....	86
7.5.1	Design	86
7.5.2	General information	88
7.5.3	Function modules for creating a line infeed in a power grid	89
7.5.4	Creating an additional VSM10	89
7.5.5	Adapting the topology and the VSM10 assignments	90
7.5.6	Performing additional parameter settings in the expert list.....	90
7.5.7	Additional parameter settings for grid monitoring	96
7.5.8	Signal interfaces.....	100
7.6	Commissioning the grid transformer	102
7.6.1	Commissioning grid-friendly transformer magnetization	102
7.6.2	Overview of important parameters.....	108
7.6.3	Function block diagrams	110

7.7	Commissioning the grid droop control	111
7.7.1	Black start in an island grid	111
7.7.2	Synchronizing an island grid to an external power grid	114
7.7.3	Overview of important parameters	120
7.7.4	Function block diagrams	122
7.8	Commissioning of dynamic grid support	123
7.8.1	Commissioning the anti-islanding function	123
7.8.2	Commissioning voltage-time monitoring	123
7.8.3	Commissioning the frequency-time monitoring	125
7.8.4	Commissioning additional monitoring functions	127
7.8.5	Overview of important parameters	128
7.8.6	Function block diagrams	129
7.9	Commissioning cos phi display	130
7.10	Commissioning supplementary controls	132
7.10.1	Commissioning active, reactive and apparent current limiting	132
7.10.2	Active current limiting	133
7.10.3	Reactive and apparent current limiting	133
7.10.4	Current limiting for dynamic grid support	134
7.10.5	Apparent current limiting for grid droop control	136
7.10.6	Notes for Active Line Modules of the Booksize format	136
7.10.7	Overview of important parameters	137
7.10.8	Function block diagrams	137
7.11	Notes for commissioning systems for operation on grids with low short-circuit power (fault level) and variable grid parameters	138
8	Device overview	139
8.1	Control Units	139
8.2	Voltage Sensing Module VSM10	139
8.3	Active Interface Modules, air-cooled	139
8.3.1	Booksize format	139
8.3.2	Chassis format	140
8.4	Air-cooled Active Line Modules for the grid infeed, chassis format	142
8.4.1	Description	142
8.4.2	Safety information	145
8.4.3	Interface description	148
8.4.3.1	Overview	148
8.4.3.2	Connection example	150
8.4.3.3	Line/load connection	151
8.4.3.4	X9 terminal strip	152
8.4.3.5	X41 EP terminal / temperature sensor connection	152
8.4.3.6	X42 terminal strip	154
8.4.3.7	DRIVE-CLiQ interfaces X400, X401, X402	154
8.4.3.8	Significance of the LEDs on the Control Interface Module in the Active Line Module	155
8.4.4	Dimension drawing	156
8.4.5	Electrical connection	158
8.4.6	Technical data	160
8.4.6.1	Permissible range for the step-up factor	165
8.4.6.2	Derating factors	165

8.5	Active Interface Modules, liquid-cooled	166
8.5.1	Chassis format	166
8.6	Liquid-cooled Active Line Modules for the grid infeed, chassis format.....	167
8.6.1	Description	167
8.6.2	Safety information	169
8.6.3	Interface description.....	172
8.6.3.1	Overview	172
8.6.3.2	Connection example	174
8.6.3.3	Line/load connection	175
8.6.3.4	X9 terminal strip	175
8.6.3.5	X41 EP terminal / temperature sensor connection	176
8.6.3.6	X42 terminal strip	177
8.6.3.7	DRIVE-CLiQ interfaces X400, X401, X402.....	178
8.6.3.8	Cooling circuit connections	178
8.6.3.9	Meaning of the LEDs on the Control Interface Module in the Active Line Module	179
8.6.4	Dimension drawing	180
8.6.5	Installation	183
8.6.6	Technical specifications	186
8.6.6.1	Permissible range for the step-up factor	189
8.6.6.2	Derating factors.....	189
8.6.7	Coolant and protection against condensation.....	189
9	Function diagrams	191
A	Appendix	193
A.1	Glossary	193
A.2	Cable lugs	194
	Index	197

Fundamental safety instructions

1.1 General safety instructions



	<p>! DANGER</p> <p>Danger to life due to live parts and other energy sources</p> <p>Death or serious injury can result when live parts are touched.</p> <ul style="list-style-type: none"> • Only work on electrical devices when you are qualified for this job. • Always observe the country-specific safety rules. <p>Generally, six steps apply when establishing safety:</p> <ol style="list-style-type: none"> 1. Prepare for shutdown and notify all those who will be affected by the procedure. 2. Disconnect the machine from the supply. <ul style="list-style-type: none"> – Switch off the machine. – Wait until the discharge time specified on the warning labels has elapsed. – Check that it really is in a no-voltage condition, from phase conductor to phase conductor and phase conductor to protective conductor. – Check whether the existing auxiliary supply circuits are de-energized. – Ensure that the motors cannot move. 3. Identify all other hazardous energy sources, e.g. compressed air, hydraulic systems, water. 4. Isolate or neutralize all hazardous energy sources, e.g. by closing switches, grounding or short-circuiting or closing valves. 5. Secure the energy sources against switching on again. 6. Make sure that the machine is completely locked ... and that you have the right machine. <p>After you have completed the work, restore the operational readiness in the inverse sequence.</p>
--	---



	<p>! WARNING</p> <p>Danger to life through a hazardous voltage when connecting an unsuitable power supply</p> <p>Death or serious injury can result when live parts are touched in the event of a fault.</p> <ul style="list-style-type: none"> • Only use power supplies that provide SELV (Safety Extra Low Voltage) or PELV- (Protective Extra Low Voltage) output voltages for all connections and terminals of the electronics modules.
--	---



! WARNING

Danger to life when live parts are touched on damaged devices

Improper handling of devices can cause damage.

Hazardous voltages can be present at the housing or exposed components on damaged devices.

- Ensure compliance with the limit values specified in the technical data during transport, storage and operation.
- Do not use any damaged devices.



! WARNING

Danger to life through electric shock due to unconnected cable shields

Hazardous touch voltages can occur through capacitive cross-coupling due to unconnected cable shields.

- As a minimum, connect cable shields and the cores of power cables that are not used (e.g. brake cores) at one end at the grounded housing potential.



! WARNING

Danger to life due to electric shock when not grounded

For missing or incorrectly implemented protective conductor connection for devices with protection class I, high voltages can be present at open, exposed parts, which when touched, can result in death or severe injury.

- Ground the device in compliance with the applicable regulations.



! WARNING

Danger to life due to electric shock when opening plug connections in operation

When opening plug connections in operation, arcs can result in severe injury or death.

- Only open plug connections when the equipment is in a no-voltage state, unless it has been explicitly stated that they can be opened in operation.

! WARNING

Danger to life due to fire spreading if housing is inadequate

Fire and smoke development can cause severe personal injury or material damage.

- Install devices without a protective housing in a metal control cabinet (or protect the device by another equivalent measure) in such a way that contact with fire inside and outside the device is prevented.
- Additionally, select the installation site so that an uncontrolled spreading of smoke can be avoided in the case of a fire.
- Ensure that smoke can escape via designated paths.

⚠ WARNING**Danger to life through unexpected movement of machines when using mobile wireless devices or mobile phones**

Using mobile wireless devices or mobile phones with a transmitter power > 1 W closer than approx. 2 m to the components may cause the devices to malfunction and influence the functional safety of machines, therefore putting people at risk or causing material damage.

- Switch the wireless devices or mobile phones off in the immediate vicinity of the components.

⚠ WARNING**Danger to life due to the motor catching fire in the event of insulation overload**

There is a greater load on the motor insulation through a ground fault in an IT system. A possible result is the failure of the insulation with a risk for personnel through smoke development and fire.

- Use a monitoring device that signals an insulation fault.
- Correct the fault as quickly as possible so the motor insulation is not overloaded.

⚠ WARNING**Danger to life due to fire if overheating occurs because of insufficient ventilation clearances**

Inadequate ventilation clearances can cause overheating with a risk to personnel due to smoke and fire. This can also result in increased downtime and reduced service lives for devices / systems.

- Ensure compliance with the specified minimum clearance as ventilation clearance for the respective component. They can be found in the dimension drawings or in the "Product-specific safety instructions" at the start of the respective section.

⚠ WARNING**Danger of an accident occurring due to missing or illegible warning labels**

Missing or illegible warning labels can result in death or serious injury.

- Check that the warning labels are complete based on the documentation.
- Attach any missing warning labels to the components, in the national language if necessary.
- Replace illegible warning labels.

NOTICE**Device damage caused by incorrect voltage/insulation tests**

Incorrect voltage/insulation tests can damage the device.

- Before carrying out a voltage/insulation test, disconnect the system/machine.

All converters and motors are subject to a high voltage test in the manufacturer's facility. As a consequence, it is not necessary to carry out additional tasks in the system/machine.

 WARNING
Danger to life when safety functions are inactive Safety functions that are inactive or that have not been adjusted accordingly can cause operational faults on machines that could lead to serious injury or death. <ul style="list-style-type: none">• Observe the information in the appropriate product documentation before commissioning.• Carry out a safety inspection for functions relevant to safety on the entire system, including all safety-related components.• Ensure that the safety functions used in your drives and automation tasks are adjusted and activated through appropriate parameterizing.• Run a function test.• Only put your plant into live operation once you have guaranteed that the functions relevant to safety are running correctly.

Note

Important safety notices for safety functions

If you want to use safety functions, you must observe the safety notices in the safety manuals.

1.2 Safety instructions for electromagnetic fields (EMF)



 WARNING
Danger to life from electromagnetic fields Electromagnetic fields (EMF) are generated by the operation of electrical power equipment such as transformers, converters or motors. People with pacemakers or implants are at a special risk in the immediate vicinity of these devices/systems. <ul style="list-style-type: none">• If affected by this, keep a distance of at least 2 m.

1.3 Handling electrostatic sensitive devices (ESD)

Electrostatic sensitive devices (ESD) are individual components, integrated circuits, modules or devices that may be damaged by either electric fields or electrostatic discharge.



NOTICE

Damage through electric fields or electrostatic discharge

Electric fields or electrostatic discharge can cause malfunctions through damaged individual components, integrated circuits, modules or devices.

- Only pack, store, transport and send electronic components, modules or devices in their original packaging or in other suitable materials, e.g. conductive foam rubber or aluminum foil.
- Only touch components, modules and devices when you are grounded by one of the following methods:
 - Wearing an ESD wrist strap
 - Wearing ESD shoes or ESD grounding straps in ESD areas with conductive flooring
- Only place electronic components, modules or devices on conductive surfaces (table with ESD surface, conductive ESD foam, ESD packaging, ESD transport container).

1.4 Industrial security

Note

Industrial security

Siemens provides automation and drive products with industrial security functions that support the secure operation of plants or machines. They are an important component in a holistic industrial security concept. With this in mind, our products undergo continuous development. We therefore recommend that you keep yourself informed with the latest information and updates of our product.

Information and newsletters can be found at:

<http://support.automation.siemens.com>

To ensure the secure operation of a plant or machine, it is also necessary to take suitable preventive action (e.g. cell protection concept) and to integrate the automation and drive components into a state-of-the-art holistic industrial security concept for the entire plant or machine. Any third-party products used must also be taken into account.

For more detailed information, go to:

<http://www.siemens.com/industrialsecurity>

WARNING

Danger as a result of unsafe operating states resulting from software manipulation

Software manipulation (e.g. by viruses, Trojan horses, malware, worms) can cause unsafe operating states to develop in your installation which can lead to death, severe injuries and/or material damage.

- Keep the software up to date.

Information and newsletters can be found at:

<http://support.automation.siemens.com>

- Incorporate the automation and drive components into a state-of-the-art, integrated industrial security concept for the installation or machine.

For more detailed information, go to:

<http://www.siemens.com/industrialsecurity>

- Make sure that you include all installed products into the integrated industrial security concept.

1.5 Residual risks of power drive systems

The control and drive components of a drive system are approved for industrial and commercial use in industrial line supplies. Their use in public line supplies requires a different configuration and/or additional measures.

These components may only be operated in closed housings or in higher-level control cabinets with protective covers that are closed, and when all of the protective devices are used.

These components may only be handled by qualified and trained technical personnel who are knowledgeable and observe all of the safety instructions on the components and in the associated technical user documentation.

When assessing the machine's risk in accordance with the respective local regulations (e.g., EC Machinery Directive), the machine manufacturer must take into account the following residual risks emanating from the control and drive components of a drive system:

1. Unintentional movements of driven machine components during commissioning, operation, maintenance, and repairs caused by, for example:
 - Hardware defects and/or software errors in the sensors, controllers, actuators, and connection technology
 - Response times of the controller and drive
 - Operating and/or ambient conditions outside of the specification
 - Condensation / conductive contamination
 - Parameterization, programming, cabling, and installation errors
 - Use of radio devices / cellular phones in the immediate vicinity of the controller
 - External influences / damage
2. In the event of a fault, exceptionally high temperatures, including an open fire, as well as emissions of light, noise, particles, gases, etc. can occur inside and outside the inverter, e.g.:
 - Component malfunctions
 - Software errors
 - Operating and/or ambient conditions outside of the specification
 - External influences / damage

Inverters of the Open Type / IP20 degree of protection must be installed in a metal control cabinet (or protected by another equivalent measure) such that the contact with fire inside and outside the inverter is not possible.

3. Hazardous shock voltages caused by, for example:
 - Component malfunctions
 - Influence of electrostatic charging
 - Induction of voltages in moving motors
 - Operating and/or ambient conditions outside of the specification
 - Condensation / conductive contamination
 - External influences / damage
4. Electrical, magnetic and electromagnetic fields generated in operation that can pose a risk to people with a pacemaker, implants or metal replacement joints, etc. if they are too close.
5. Release of environmental pollutants or emissions as a result of improper operation of the system and/or failure to dispose of components safely and correctly.

Note

The components must be protected against conductive contamination (e.g. by installing them in a control cabinet with degree of protection IP54 according to IEC 60529 or NEMA 12).

Assuming that conductive contamination at the installation site can definitely be excluded, a lower degree of cabinet protection may be permitted.

For more information about residual risks of the components in a drive system, see the relevant sections in the technical user documentation.

General information

To assess the inverter system required, the following distinction can be made between the types of power generation:

- Power generation with rotating machines
- Power generation without rotating machines

In particular, the amount of power generated depends largely on fluctuating ambient conditions, such as wind speed or exposure to sunlight. For energy storage applications, an additional dependency is the charge state of the storage source. When a generator is directly operated on the grid, the amplitude and frequency of the generated voltage vary accordingly, and decoupling of the producer and consumer grid is required. This task is handled using state-of-the-art power electronics.

Both in power technologies based on fossil fuels, or nuclear energy as well as regenerative energies with solar thermal, wind, water or biomass, generators are normally used to convert the kinetic energy into electrical energy and supply it to the consumers via power grids.

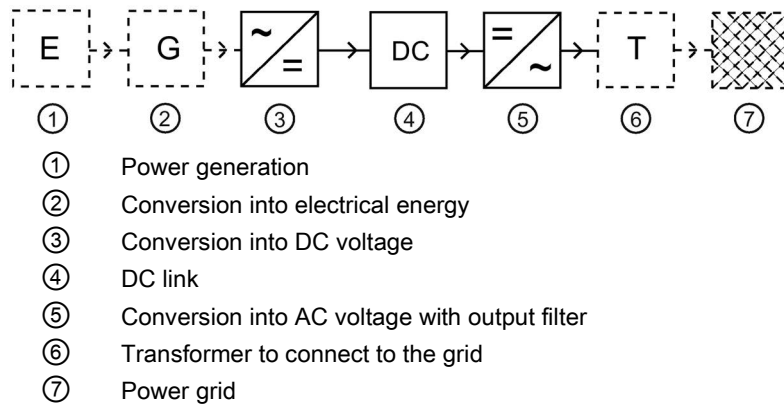

Figure 2-1 Energy flow for power generation with rotating machines

For power sources such as batteries, fuel cells or photovoltaic, for example, the electrical energy is converted using chemical processes or semiconductors. As a rule, the resulting DC voltage must be converted to a 3-phase AC voltage for distribution in the power grid.

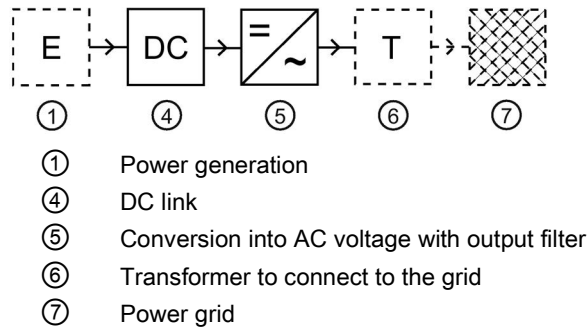

Figure 2-2 Energy flow for power generation without rotating machines

Grid types

3.1 Power grid

A power grid covers a wide area, is generally supraregional and comprises large power generating units (regarding the electric power). It is operated by a power supply utility, which is responsible for the grid, and therefore also grid codes.

Generating units, which feed into a power grid must synchronize their voltage and frequency to that of the power grid.

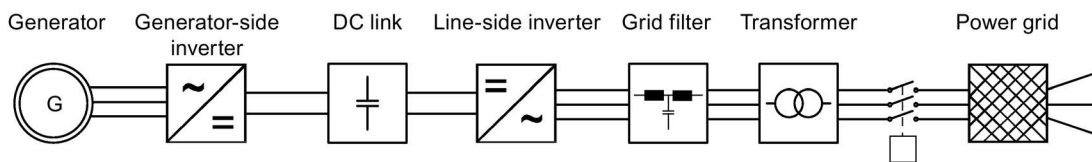

Figure 3-1 Schematic diagram of a power generating system connected to a power grid

Requirements

Every power grid operator has defined conditions when it comes to feeding in electrical energy. The precise limit values can vary between different countries, and are defined in the form of grid codes. As a consequence, they must be considered on a system-for-system basis.

For example, in Germany this is the "Federal Association of Energy and Water Industry e. V." (in short: BDEW) which has specified the following conditions for energy infeed:

- Riding through grid faults (FRT):
Not isolated from the grid for defined, short grid faults and disturbances.
These especially involve voltage dips or short-circuits between two or all 3 phases.
- Dynamic grid support:
During one of the previously mentioned voltage dips or short-circuits, a reactive current must be impressed into the grid, which counteracts/corrects the voltage deviation.
- Provision of a steady-state reactive power for compensation if necessary
- Maintaining the limits of the voltage quality formulated in EN 50160

All energy suppliers must satisfy these conditions.

Function modules for the power grid

When operating a generating unit connected to a power grid, a power utility company can specify grid codes. Software functions are required to fulfill the requirements resulting from grid codes. These are defined in function modules, and must be explicitly activated.

The following function modules of the Active Line Module are typically required to satisfy the requirements arising from grid codes:

- Line transformer function module (Page 34)
- Function module, dynamic grid support (Page 40)

If a specific grid code does not have to be complied with, then it is not necessary to enable the "Dynamic grid support" function module. This can apply to battery energy storage systems, if they do not represent power generating units.

3.2 Island grid

An island grid supplies a limited area and has no connection to the public grid or to other grids. The utility company operating the grid must maintain the balance between used and generated power in the island grid; an energy storage system can be used.

The company operating an island grid can define their own grid codes. These can deviate from the regulations of public grid operators (power utility companies).

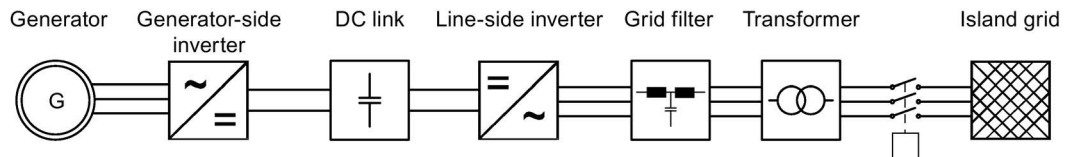

Figure 3-2 Schematic representation of an island grid

Requirements placed on distributed power producers

- Black start of the island grid
This function involves establishing an island grid voltage starting from zero with the disconnector open to the external grid. Generally, a component black start is required (24 V DC supply).
- Controlling the grid voltage and frequency, and quickly adapting the generated power to the varying load conditions
- Provision of the entire short-circuit current in the event of a short-circuit
- Provision of reactive power for grid support
- Reestablishing the voltage and maintaining the frequency after the short-circuit has been cleared

Requirements placed on a higher-level island grid control

- Matching the generated power (active power/reactive power) at the rated frequency to the load power (active power/reactive power)

Using an isolating transformer

- An isolating transformer with neutral point on the island grid side must be used if a neutral conductor is required in the island grid.
- An isolating transformer must also be used in order to avoid inadmissible ground currents, which can occur as a result of clocked (PWM) frequency converters connected to the power generating unit.

Function modules for an island grid

Additional software functions are required for operation in an island grid. These are defined in function modules, and must be explicitly activated.

The following function modules of the Active Line Module are required for operation in an island grid:

- Line transformer function module (Page 34)
- Function module for grid droop control (Page 35)

3.3 Microgrid

A micro grid represents a locally constrained electrical system with several power generating units, loads and possibly energy storage systems. This can be connected to a large power grid – or can also be independently operated (i.e. an island grid with one or several power generating units).

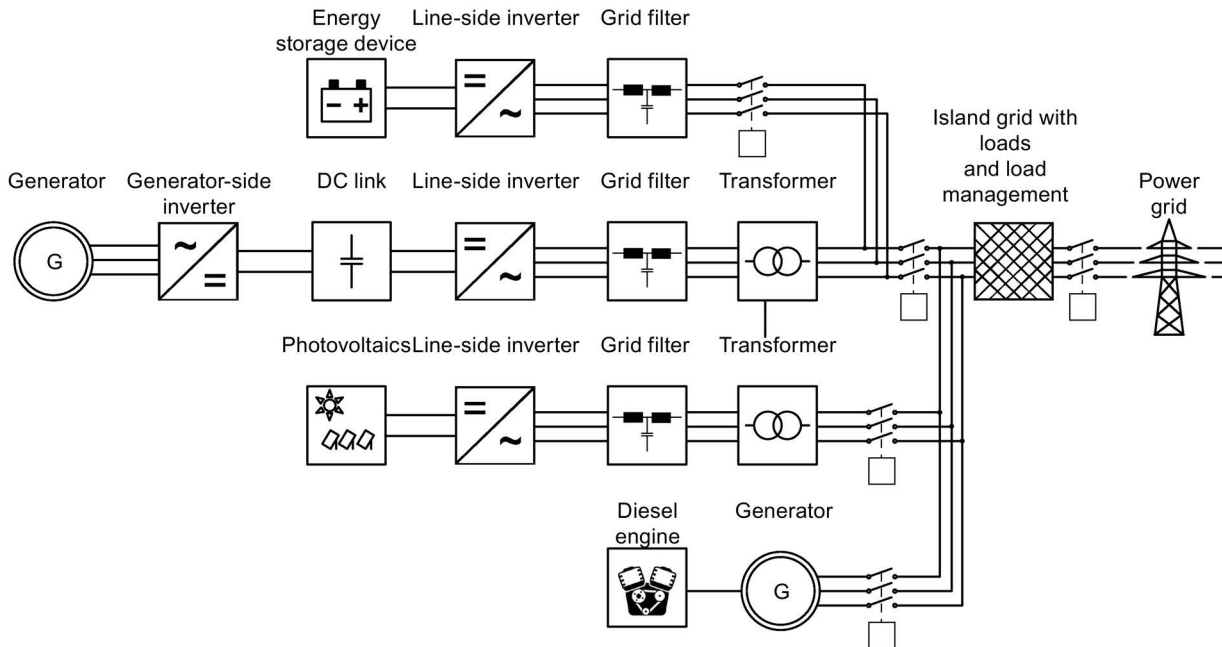

Figure 3-3 Microgrid

Requirements

If the micro grid is separated from the power grid, then the same requirements apply as for an island grid. When running up, the power generating units must also be synchronized to the actual grid frequency and voltage. In addition, the energy mix must be controlled, i.e. the percentage participation of the individual power generating units to reliably supply the connected loads ("load sharing").

However, if it is coupled with the power grid, then the same requirements apply as for a power generating unit, which feeds into the power grid.

Further, the transition between the two operating modes must be able to be reliably handled.

Function modules for a micro grid

A micro grid can form an island grid, but can also be connected to a power grid. This means that all of the requirements specified in the two previous chapters must be fulfilled.

Correspondingly, all of the previously mentioned function modules must be activated in the Active Line Module.

Standards and directives

When feeding electric power into a grid, different requirements can apply depending on the actual location. Frequently, the requirements depend on the particular country, and in some cases depend on the specific guidelines (grid codes) of the individual power utility company. This is complemented by the individual conditions resulting from the power generating application itself. Complying with these requirements requires using special hardware components and settings in the higher-level control system.

The following list of notes regarding the applicable standards does not claim to be complete.

Active Line Modules in the chassis format from the realm of industrial applications satisfy the following properties.

4.1 Protection and safety

Standard EN 61800-5-1 is complied with in the area of protection/safety.
EN 61800-5-1: Adjustable-speed electrical power drive systems
Part 5: Safety requirements
Main section 1: Electrical and thermal requirements

For the North American market, Active Line Modules comply with UL508C
UL508C: Power Conversion Equipment

4.2 EMC

Active Line Modules comply with EMC standard EN 61800-3
EN 61800-3: Variable-speed electric drives
Part 3: EMC - requirements and specific test methods

4.3 Grid harmonics

When using self-commutated IGBT infeed devices (for example, S120 Active Line Modules), the limit values of standard IEEE 519 (Recommended Practices and Requirements for Harmonic Control in Electrical Power Systems) are complied with.

4.4 Grid codes/standards

Complying with the grid codes of a power utility company is a basic precondition for feeding power into an electric grid. The details of these grid codes differ around the globe and depend on the voltage class, country and power utility company. However, they are very similar regarding requirements placed on the response when grid faults occur, for grid and plant protection and for grid harmonics and/or EMC issues.

Complying with grid codes such as these requires a complete system with power source, inverters, filters and protective devices and equipment. Certification to comply with a directive is only possible for a complete power generating system (for instance, refer to the graphics in Chapter "General"), and cannot be achieved for individual components.

SINAMICS Active Line Module inverters, with their options for riding through and identifying line faults, reactive power control and measured value acquisition – as well as grid and system protection – support all of the functions necessary to certify a complete system. Complying with limit values for voltage and current harmonics requires grid and EMC filters, which are adapted to address the specific requirements. Whether SINAMICS line filter Active Interface Modules, possibly supplemented with additional reactors or filters, can be used, must be checked on a case-for-case basis.

4.5 Standards for Germany, Italy, USA

Requirements/standards for connecting to the grid in Germany

Connecting to a public low-voltage grid

Directive VDE-AR-N 4105 applies when feeding power into the German low-voltage grid. It involves the complete power generating system, which is why conformance of the system must be clarified by the system manufacturer.

Sinamics Active Line Modules in the booksize format with the available supplementary functions and the appropriate circuitry comply with all of the requirements of the directive, which involve the grid converter. Siemens can provide the appropriate instructions, test reports and partial declarations of conformity. Based on these, the system manufacturer can prove the conformance of his power generating unit. A special certificate for the converter feeding into the grid (infeed converter) is not required.

VDE application regulation VDE-AR-N 4105:2011-08: Power generating systems connected to the low voltage grid, minimum technical requirements for connection and parallel operation of power generating systems connected to the low voltage grid

Connecting to a public low-voltage grid

BDEW: Technical directive for power generation systems connected to the medium-voltage grid, directive for connection and parallel operation of power generating systems connected to medium-voltage grid, Edition June 2008, 4th Supplement: "Regulations and transition periods for specific requirements as supplement to the technical directive", from January 1, 2013.

Requirements/standards for connecting to the grid in Italy

Standards CEI 0-21 for the low-voltage grid and CEI 0-16 for the medium-voltage grid regulate how power is to be fed into the Italian grid. Here, special certificates for the converter are mandatory, which can only be issued by an appropriately authorized test laboratory. Siemens offers a 120 kVA grid converter – certified to CEI 0-21 – as a ready-to-connect control cabinet, based on the Sinamics S120. Higher power ratings are possible by connecting units in parallel. Additional certified solutions are presently being developed – please contact your local Siemens person for information regarding the current state.

Requirements/standards for connecting to the grid in the USA

In the USA, standard UL1741 (UL Standard for Safety for Inverters, Converters, Controllers and Interconnection System Equipment for Use With Distributed Energy Resources) must be always be applied and conformed to when feeding power into the grid (i.e. with the exception of several specific states).

Here, a certificate for the converter is mandatory, which can only be issued by an appropriately authorized test laboratory. Siemens offers a 120 kVA grid converter – certified to UL1741 – as a ready-to-connect control cabinet. It is based on the Sinamics S120 Active Line Module Booksize. Higher power ratings are possible by connecting units in parallel.

The Sinamics S120 chassis components (Active Line Module + Motor Module air cooled) have the "UL1741 recognized" stamp. This means that system integrators can develop a UL1741-certified converter solution ("UL1741 listed").

UL certification is available for the SINAMICS software (SINAMICS firmware 4.7: UL1998).

Function modules

The function modules, which are required to feed power into an island grid or micro grid – or to fulfill the grid code requirements of a power grid – are described in this chapter.

5.1 Overview

Power and island grids have different requirements relating to the open-loop and closed-loop control for grid infeeds. The firmware includes function modules that can be selected depending on the particular control task. The parameters contained in the function modules can only be seen after first activating the function module; information about the parameters is provided in the List Manual.

- **Grid transformer function module**

The "Grid transformer" function module is used to magnetize, synchronize and to connect a grid transformer to a power or island grid. In addition, using this function module in conjunction with the "Grid droop control" function module, a black start can be realized for an island grid. This can then be subsequently synchronized to a power grid.

The "Grid transformer" function module does not require a license.

The function module includes the following subfunctions:

- Grid-friendly transformer magnetization
- Identification of the transformer data
- Transformer model to take into account the transformer for the grid control and dynamic grid support
- Negative sequence system current control to compensate for grid dissymmetries
- DC component control to avoid DC components in the AC current, therefore avoiding transformer saturation
- Support of additional VSM10 modules to measure the voltage for transformer magnetization and synchronizing an island grid
- Line filter and transformer monitoring
- Additional grid PLL and synchronizing functions
- Extended current limits

This function module is activated in the STARTER operating software.

A detailed description of the activation is provided in Chapter "Commissioning the grid transformer (Page 102)".

- **Function module for grid droop control**

The "Grid droop control" function module enables an island grid to be created. The inverter for feeding into the grid has the task of controlling the frequency and the voltage in the grid, and assumes an "grid former function". The power that is output is defined by the consumers (loads) and where relevant, other power generating units in the island grid. The DC voltage present in the DC link must be controlled by other participants, such as generator-side inverters, or provided by other sources (e.g. from a battery).

The "Grid droop control" function module requires a license that must be (additionally) ordered.

The transition between the operating modes "Grid control" and "Current control or Vdc control" is possible at any time while operational. However, it should be noted that when exiting grid control, the power is controlled down to zero. As a consequence, loads still available in an island grid must be temporarily supplied from another source. When grid control is exited, at least one other power generating unit in the island grid must still control frequency and voltage.

The function module includes the following subfunctions:

- Grid droop control for voltage and frequency
- Grid voltage control for the connection point
- Island grid black start to establish an autonomous island grid
- Synchronizing an island grid to another grid
- Provision of short-circuit currents in the case of a grid fault (riding through grid faults)
- Supplementary droop and damping input to avoid load peaks or power oscillations to stabilize the grid (emulation of the generator dynamic response)

- **Function module dynamic grid support**

The "Dynamic grid support" function module allows grid faults to be ridden through and allows grid-supporting reactive currents to be injected; this is specified in many grid codes in order to clear short-circuits. Contrary to line droop operation for island grids, in this particular case, the Active Line Module is operated as grid support element with DC link voltage and grid current control. In this operating mode, the complete power injected into the DC link is output to the grid.

The "Dynamic grid support" function module requires a license that must be (additionally) ordered.

The Active Line Module is operated in current and DC link voltage control.

The grid droop control must be deactivated ($p5401 = 0$).

As a consequence, "Dynamic grid support" is typically used for feeding power grids. However, this operating mode can also make sense in island grids, e.g. for PV inverters, which are operated with DC link voltage controlled to optimize the yield. Other power generating units in this island grid must ensure adequate frequency and grid voltage control.

In addition to dynamic support, the function module also provides a range of comprehensive functions for grid monitoring regarding frequency and voltage amplitudes. The monitoring limits can be parameterized with either a fixed value or with a characteristic, as a function of time.

Further, using the anti-islanding function, the unintended and undesirable creation of an island grid can also be detected. This function is normally used when generating power in a power grid. Isolating a partial grid without adequate frequency and grid voltage control causes the Active Line Module to be shut down (which is connected to this partial grid).

The function module includes the following subfunctions:

- Dynamic grid support with reactive current (symmetrical and non symmetrical grid support can be set)
- Provision of short-circuit currents in the case of a grid fault (riding through grid faults) to comply with grid codes
- Active anti-islanding detection with active frequency shift algorithm
- Extended voltage and frequency check for automatic restart after a grid fault
- Freely-definable curves with support points (voltage-time monitoring and frequency-time monitoring) to monitor voltage and frequency during a grid fault corresponding to local grid codes).

- **Cosinus phi display function module**

The "Cosinus Phi display" function module provides the option of providing a precise cos phi measurement at the connection point: typically <1 %).

An appropriate current transformer with voltage output can be connected to VSM10 to sense the current.

The function module includes the following subfunctions:

- Evaluation of the displacement factor and the connection point
- Calculation of the $\cos\phi$ value

- **Additional closed-loop controls function module**

Most functions of this function module (negative sequence system current control, extended current limits, synchronous controller parameterization) are also included in the "Grid transformer" and "Dynamic grid support" function modules.

The "Supplementary controls" function module is selected if the main functions of the "Grid transformer" and "Dynamic grid support" modules are not required.

Function modules requiring a license

The function modules "Grid control" and "Dynamic grid support" must be ordered as an option for the SINAMICS S120 memory card:

- Booksize device:
Licensing corresponding to the power rating and application
- Chassis format devices:
S01: Dynamic grid support for feeding power into a power grid
S02: Grid control for feeding power into an island grid

Example of a memory card with firmware V4.7 and with option S02 for a device in the chassis format: 6SL3054-0EF00-1BA0-Z S02

5.2 Typical applications of grid infeed to generate power

The function modules for grid infeed are typically required for the following applications:

- **Photovoltaic (PV) inverters for power grid operation**
"Grid transformer" and "Dynamic grid support" function modules.
- **Battery energy storage systems with the option of island and power grid operation**
"Grid transformer" and "Grid droop control" function modules
When the converter is operated on a power grid, the "Dynamic grid support" function module may only be used if the battery system is considered to be a power generating system (instead of a load).
- **Hydroelectric turbine and small wind turbine**
"Grid transformer" and "Dynamic grid support" function modules.
The "Grid droop control" function module is only required for island grid operation.
- **Application Shaft Generator Drive for use onboard ships**
"Grid transformer" and "Grid droop control" function modules.
- **Grid couplings, applications to improve the grid quality**
"Grid transformer", "Grid droop control" and "Dynamic grid support" function modules.
- **Grid emulation (e.g. device tests for countries with other grid parameters, e.g. USA <-> Europe)**
"Grid transformer" and "Grid droop control" function modules.

Note

The following rules apply when using function modules for the grid infeed:

- **"Grid transformer" function module (license not required)**
is necessary, if a grid transformer is used in a power generating application, or
 - an island grid is to be operated, or
 - the measured data is required from additional VSMS.
 - **"Grid droop control" function module (a license is required)**
operation in an island grid with participation in the grid U/f control (grid former operation), typical applications: Generating units in the island grid, grid buffering with battery).
 - **"Dynamic grid support" function module (a license is required)**
operation in a power grid where grid codes must be complied with – or requirements relating to grid monitoring apply (anti-islanding, fault ride through).
 - **"Cosinus phi display" (a license is not required)**
precise cos phi measurement at the connection point.
-

5.3 Description of the function modules

5.3.1 Line transformer function module

Task

The main task of this function module is to magnetize a line transformer before connecting the power generation system to the grid. This magnetization is always necessary and expedient when the grid transformer forms part of the system and is also disconnected from the grid when the system is shut down. Without magnetization by the inverter, very high transformer inrush currents would otherwise flow when closing the circuit breaker, and these could, among other things, cause excessive grid harmonics.

Before connecting a power generating system to the grid using a circuit breaker, the voltage amplitude, frequency and angular phase position is synchronized with that of the grid.

In addition, the function module allows identification of the transformer data. This can compensate the voltage drop across the transformer during operation and optimize the behavior of the power generation plant at the grid connection point.

Non-symmetrical currents can be specifically compensated using a dedicated current control for negative sequence systems.

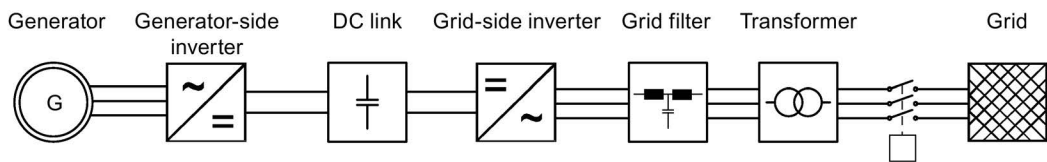

Figure 5-1 Principle of a power generating system with transformer and circuit breaker

5.3.1.1 Grid-friendly transformer magnetization

This function controls the magnetization of the grid transformer before connection to the existing grid. The energy for magnetization must be provided by the DC link.

Two VSM10s are required for this function. The first VSM10 (included in the Active Interface Module Chassis format – or to be additionally provided for Active Line Modules Booksize format) measures the output voltage of an Active Line Module at the transformer secondary. The second VSM10 (called VSM10(2) in the following) measures the grid voltage at the transformer primary. The amplitude, frequency and phase position of the voltages are calculated in the Control Unit. The circuit breaker can be closed if synchronism has been achieved – and therefore the primary transformer voltages and grid voltages match one another.

The adjustable parameters of VSM10(2) become visible when the "Grid transformer" function module is activated in the expert list.

5.3.1.2 Identification of the transformer data

The main and leakage inductance of the transformer are identified – together with the phase shift and the voltage correction.

5.3.1.3 Line filter and transformer monitoring

As already described, network connection regulations stipulate the provision of short-circuit current during short-term short-circuits in the power grid. Short-circuits within the power generation system (between the inverter and the network connection point) however must result in an immediate shutdown to prevent additional damage to the system.

With the aid of the line filter and transformer monitoring function, a distinction/detection is carried out for external line short-circuits (requiring grid support) and internal short-circuits that result in a safety shutdown.

5.3.2 Function module for grid droop control

Task

In normal operation, the Active Line Module acts as a grid support by injecting sinusoidal line currents. The function module "Grid droop control" also enables grid former operation, i.e. the line voltage and line frequency are controlled instead of the DC link voltage and the reactive current. Droop characteristic curves using a stable network operation is possible with other generators (e.g. diesel generators) in an island grid without further communication connection.

Using this function module, an Active Line Module is in a position to establish island grids, operate them so that they remain stable (as single grid former – or together with other generating units), and when required, to synchronize with external grids.

Prerequisite for the operating mode "Grid control" is that the DC link voltage is specified or controlled by one of the connected power generating units (generator-inverter, battery, photovoltaic array, etc.).

Note

Automatic shutdown

The Active Line Module switches to this operating mode in the case of frequency faults (120% of the set upper frequency threshold p0284 – or 80% of the lower frequency threshold p0285) and shuts down to protect itself (overcurrent, overvoltage, overtemperature, etc.). Smaller frequency and voltage deviations – as well as voltage dips or phase steps in the grid – do **not** result in a shutdown as a result of the fault ride through function (FRT). The filter monitoring p3667 must be activated in order to guarantee that for system-internal short-circuits (e.g. in the Active Interface Module), the system is immediately shut down. Depending on the requirements relating to the particular application, for example, the parameterizable grid monitoring (p5540 and higher) can be used.

The shutdown limits for overcurrent (F30001, F6200 to A6205 = 128), overvoltage (Vdc_max, F30002, F30003, F6200 to A6205 = 16), overtemperature, I2t are described in the List Manual.

Functions

- Control of line voltage and line frequency (grid former)
- Stationary and dynamic load distribution to other energy producers in the network using droop characteristics
- Provision of reactive current and short-circuit current for clearing network incidents
- An autonomous island grid can be established and maintained using the "Island grid black start" function.
- An island grid can be connected to an external grid using the "Synchronize island grid to an external grid" function. To achieve this, the voltage amplitude and frequency of the island grid is modified in operation, and before closing the disconnecter, adapted to that of the external grid.
- Droop function to control the frequency and voltage of the network, including load distribution
- Sequential control and current limitation control for mains voltage dips and short-circuits
- Modulation depth control to achieve the optimum modulation depth for minimum grid harmonics
- DC component control ensures a line current that is free from DC components and thus avoids saturation effects in the transformer
- Voltage control for compensating the voltage drop at transformer
- Damping elements and filters to stabilize an island grid

Grid control operating mode

As explained at the beginning of this Chapter, the "Line droop control" function module includes the new "Grid control" operating mode to control the grid frequency and grid voltage in an island grid. The essential differences between normal current and DC link voltage control with respect to grid control operation are listed in the following table.

	Closed-loop control mode	
	Grid current DC link voltage	Grid frequency Grid voltage
Island grid	System acts as consumer or as lower-level generating subunit with low power rating (grid support)	The system acts as exclusive or powerful generating unit in the island grid
Infeed active power	Infeed of the entire power available in the DC link infeed into the grid, regardless of the operating state of the grid (under standard conditions)	Contribution to frequency and voltage control in the network; time-variant infeed of active power to the network depending on the operating point
Load distribution	Only by external setpoint input from the higher-level power management system	With the aid of droop characteristics
Stationary reactive power compensation	possible (fixed setpoint)	Automatic provision of the required line reactive power
Dynamic reactive power compensation (incl. grid fault)	Only possible with "Dynamic grid support" function module or by external setpoint input	Automatic provision of the required line reactive power
Short-circuit current for "Grid short-circuit" fault type	Only possible with "Dynamic grid support" function module	Devices in the chassis format: Automatically up to 123 % of the normal maximum inverter current Devices in the booksize format: Up to 90 % of the normal maximum inverter current
DC link voltage	Control of the DC link voltage by the line inverter	Maintenance of the DC-link voltage required by other components

Synchronizing to an existing grid is possible in both operating modes.

After synchronization, in operation, a transition can be made at any time between normal current/voltage DC link control and grid control. In these two modes, the line inverter can operate as a power source or load, depending on the valid setpoints for DC link voltage and reactive current or line frequency and line voltage.

In the grid control operating mode, power oscillations in the grid, e.g. after a load change, can result in energy flowing in the DC link – and in turn a fast increase of the DC link voltage. This has to be especially taken into account if the power generating component cannot accept any power (e.g. a diesel generator or a fully-charged battery). Depending on the requirements of the application, a temporary load may be required, for instance, a braking resistor.

Droop function to control the frequency and voltage of the network, including load distribution

Using the droop functions, is possible to establish an island grid and supply it, together with other generating units. In this case, all of the generating units in this island grid must have comparable droop functions. Then, an additional communication link between the generating units is not required for the common control of the line frequency and line voltage. The parameterization of the droop functions defines the load distribution between the power generating units.

The frequency droop calculates the setpoint for the output frequency of the Active Line Module (i.e. a line frequency setpoint) depending on the active power absorbed or output.

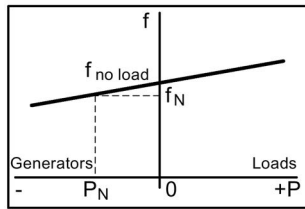

Figure 5-2 Frequency droop

The voltage droop defines a setpoint for the output voltage, depending on the reactive current that is absorbed or output.

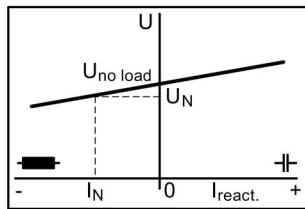

Figure 5-3 Voltage droop

If all of the generating units in the grid have a comparable droop function, then a stable operating point for frequency and voltage is obtained in the island grid. Restoring rated frequency and rated voltage can be achieved using a slow higher-level secondary control of the no-load frequency.

Oscillation damping of the line voltage

The supplementary frequency droop can be used to dampen power oscillations or oscillations in the line voltage amplitude after load changes.

5.3.2.1 Black start in an island grid

Description

The "Island grid black start" function allows an autonomous island grid to be established and subsequently maintained with the grid droop control.

For a black start (p5580 = 2) initially, a check is made as to whether the island grid is in a no-voltage condition. The circuit breaker between the infeed and the island grid is closed and the infeed voltage increased until the rated voltage in the island grid is reached.

The automatic black start (p5580 = 3) can be set via the mode setting. If the island grid is already at a certain voltage level, then an immediate switch is made into grid droop operation (standard switching to an existing grid). Otherwise, a black start is realized.

Preconditions

The "Grid transformer" function module is required.

The Active Line Module requires a power supply in order to ramp-up the grid (e.g. from an uninterruptible power supply); this means that the device fan and additional components can be supplied with a 24 V DC control voltage.

Further, the actual power source to supply the DC link is required. The DC link must be established using suitable pre-charging.

If there is a disconnecter between the infeed and island grid, then a 2nd VSM10 is required in order to measure the island grid voltage with which the infeed should be connected.

5.3.2.2 Synchronizing an island grid to an external power grid

Before connecting an island grid with an external power grid at a specific voltage using a circuit breaker, the voltage amplitude, frequency and phase must be synchronized with that of the external power grid. The "Island grid synchronization" function is used for this purpose.

A typical application involves connecting a micro grid with a power grid (depending on the particular demand) or establishing a power grid from several micro grids.

5.3.3 Function module, dynamic grid support

The function module includes the "Dynamic grid support" function to support the grid when voltage dips occur – and the "Grid monitoring anti-islanding" function in order to detect an undesirable creation of an island grid.

The "Dynamic grid support" function is used to ride through grid faults in a current-controlled or grid current-impressed operation with DC link voltage control in the Active Line Module. Typical application examples include photovoltaic inverters or grid inverters belonging to wind turbine systems connected to a power distribution network. Contrary to this, in the previous chapter, grid voltage-impressed operation without DC link voltage control for island grid applications was discussed.

5.3.3.1 Dynamic grid support

The "Dynamic grid support" function controls the network in the event of voltage dips for a defined time, as stipulated by the regional network operators.

Non-symmetrical currents can be specifically compensated using a dedicated current control for negative sequence systems.

The infeed systems in a medium-voltage network must participate in dynamic grid support, typical applications include for example:

- It is not permissible that they are disconnected from the grid when grid faults occur.
- During a grid voltage fault, they must support the grid by injecting reactive power (e.g. during a grid short-circuit by providing a short-circuit current).
- They may not draw more inductive reactive power after clearing the fault than prior to occurrence of the fault.

Function

The dynamic grid support includes the necessary additional functions for monitoring and control of the grid. This allows most of the important grid codes to be satisfied. It must be checked on a case-for-case basis whether different codes are also fulfilled and, if necessary, parameter settings must be adapted accordingly.

With dynamic grid support activated, the regulated boost mode of the Active Line Module is maintained even when network incidents occur (amplitude and phase errors in the network voltage). The grid is supported by injecting an additional reactive current, which is calculated according to a parameterizable characteristic, as a function of the grid voltage fault.

The supplementary setpoint for the reactive current controller causes an increase of the output voltage if the line voltage is too low, and reduction of output voltage if the line voltage is too high.

Example of a characteristic curve for dynamic grid support in accordance with German BDEW Guidelines for connection to medium-voltage grids

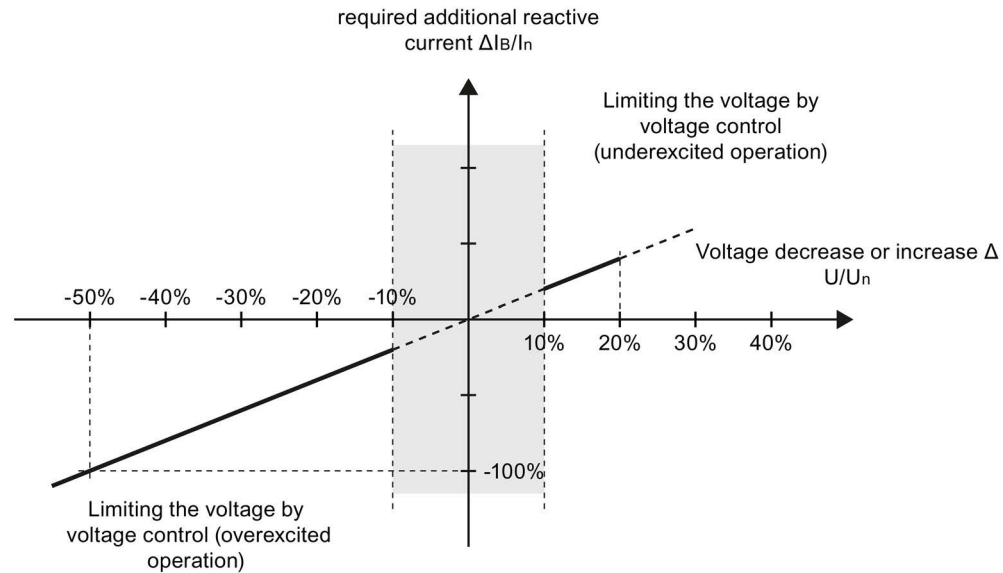

Figure 5-4 Dynamic grid support with voltage control in accordance with German BDEW Guidelines

Explanations for voltage control:

- Voltage deadband:
In the range between $0.9 \times U_n \leq 1.1 \times U_n$, there is no requirement for dynamic grid support.
- The rise time is < 20 ms (typical ~ 10 ms).
- Voltage control after returning to the voltage deadband is maintained for a further 500 ms (p5507[0], parameterizable).
- Reactive current: $I_B = k \times ((U - U_0)/U_n) \times I_n$
- The default setting of the characteristic curve parameter corresponds to the characteristic in accordance with the previous diagram.
- The magnitude and symmetry of the active and reactive current can be defined during a fault ride through. This means that adaptations can be made to address grid codes as well as special applications.

$$\Delta I_B = I_B - I_{B0}$$

$$\Delta U = U - U_0$$

k: Gradient of the characteristic

U_n : Rated voltage

U_0 : Voltage before the fault

U: Instantaneous voltage
(during the fault)

I_n : Rated current

I_{B0} : Reactive current before the fault

I_B : Reactive current

Example of a grid code: German BDEW Guidelines

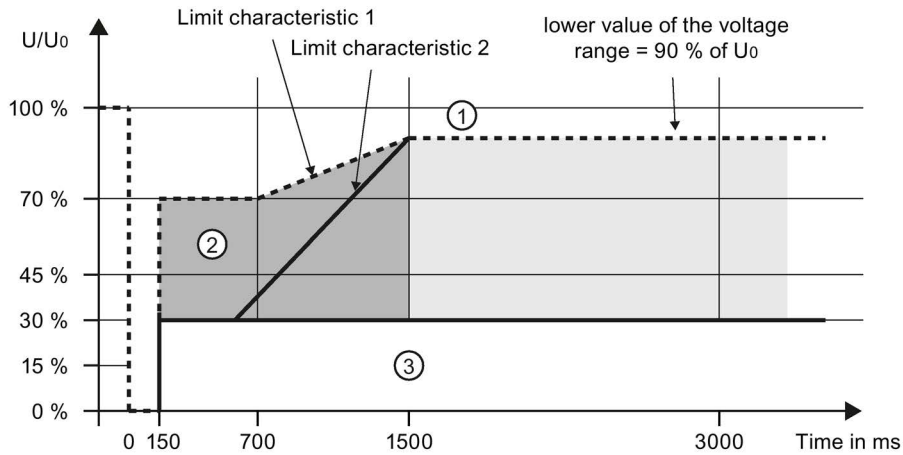

Figure 5-5 Limiting characteristics for the voltage characteristic at the network connection point

Explanation of the voltage characteristic:

- ① In the area above the borderline 1, the infeed operation is stable
- ② In the area between borderline 1 and borderline 2, it must be agreed with the network operator whether the infeed mode should be maintained or whether the infeed is to be disconnected from the power system.
- ③ Careful disconnection from the network may take place in this area.

The function "dynamic grid support" function ensures that the power inverter can maintain grid support for at least the time required in this grid code example. Depending on the parameter settings and the thermal preload, a grid short circuit can be supported for up to 2 s. Time-related shutdown conditions (e.g. in accordance with the diagram above after 150 ms short-circuit), which differ according to specific grid codes, must be implemented using the grid monitoring (p5540ff), with DCC or in a higher-level controller.

Note

Automatic shutdown

The Active Line Module switches to this operating mode in the case of frequency faults (120% of the set upper frequency threshold or 80% of the lower frequency threshold) and shuts down to protect itself (overcurrent, overvoltage, overtemperature, etc.). In all other cases, the Active Line Module supports the network by injecting a reactive current in accordance with the characteristic curve..

The shutdown limits for overcurrent (F30001, F6200 to A6205 = 128), overvoltage (Vdc_max, F30002, F30003, F6200 to A6205 = 16), overtemperature, I2t are described in the relevant manuals.

NOTICE**Damage to other grid components as a result of overvoltage**

Without using additional monitoring functions, the dynamic grid support can mean that even when a subgrid is completely isolated from the power grid (unintentional creation of an island grid), PWM/pulsed operation of the Active Line module in the disconnected subgrid is maintained.

It is especially important to note that the shutdown conditions previously mentioned regarding converter self-protection do **not** prevent AC overvoltages and frequency changes occurring in the remaining grid formed if high ohmic grid faults occur; these can possibly mean that other components in the subgrid either malfunction or are damaged.

As a consequence, when activating the dynamic grid support, using suitable supplementary measures it must be guaranteed that the voltage and frequency limits are maintained in each individual application scenario.

- Using the "Grid monitoring" function, the function module already provides suitable internal monitoring functions. To do this, activate the grid monitoring with p5540ff, and suitably parameterize the function (see Commissioning of dynamic grid support (Page 123)).
- Alternatively, you can implement grid and plant protection, for example using DCC in the Control Unit, in an external control or using an autonomous protection system.

Difference to normal operation

In normal operation, a severe grid fault (thresholds for tripping A06205 are exceeded) will disable the pulses as well as the boost mode, until the grid has been restored. Injection of active or reactive current to the network is therefore not possible while the fault is present.

By evaluating the alarm bits r3405.2 or re-parameterizing alarm A06205 into a fault, it is also possible to achieve a fast safety shutdown in the event of grid faults.

5.3.3.2 Grid monitoring anti-islanding

The "Grid monitoring anti-islanding" function allows an active island grid detection to be implemented (anti-islanding).

If the power generating system feeds into a power grid, then it is possible that the connection to the grid is interrupted. This disconnection can either be deliberate (e.g. a subgrid is tripped due to overload or if work is being carried out on the system) or inadvertently (e.g. sudden cable interruption in the case of a storm or construction work). An island grid is created if there are loads between the power generating system and the point of disconnection.

This island grid is undesirable and unstable as there is no grid control. In order to protect personnel and to facilitate normal restoration of the grid, the power generating system must identify that an island grid has been formed (anti-islanding detection), and must shut down the grid infeed.

Function

As the grid control is missing, generally the creation of an island grid quickly results in violation of the frequency and voltage limit values. As a consequence, it is detected by the frequency and voltage monitoring function. However, if the power generated by the power generating system and the power used in the remaining island grid are the same, then frequency and voltage remain within the limit values and the creation of an island grid is either not detected at all – or not quickly enough.

For cases such as these, an active anti-islanding function is required such as the "Grid monitoring anti-islanding" of the Active Line Module. It operates according to the frequency shift technique, i.e. if the function is activated, then the Active Line Module attempts to continually actively change the line frequency. However, this can only occur in an island grid, i.e. the creation of an island grid is always reliably and quickly detected.

Note

During a grid short-circuit ($r_{5502.4} = 1$), the active anti-islanding function is inhibited, so that this grid fault can be ridden through and the supporting reactive current injected.

However, if it is necessary to satisfy requirements regarding shutting down the formation of an island grid, the subsequently described voltage-time monitoring can be employed, for example.

5.3.3.3 Voltage-time monitoring

The voltage-time monitoring provides two characteristics with 10 adjustable interpolation points to set the time and the associated voltage value.

One characteristic is used to monitor the voltage increase (HVRT, high voltage ride through), the other characteristic is used to monitor the voltage dip (LVRT: low voltage ride through).

Status bits and messages are used to signal if the defined tolerance range is violated for the line voltage characteristic.

This means that the grid voltage can be monitored, and after a grid fault, a response that complies with the power utility company initiated.

5.3.3.4 Frequency-time monitoring

The frequency-time monitoring provides two characteristics with 10 adjustable interpolation points to set the time and the associated frequency value.

One characteristic is used to monitor the frequency increase (HFRT, high frequency ride through), the other characteristic is used to monitor the frequency decrease (LFRT, low frequency ride through).

Status bits and messages are used to signal if the defined tolerance range is violated for the line voltage characteristic.

This means that the grid frequency can be monitored, and after a grid fault, a response that complies with the power utility company's grid codes initiated.

5.3.3.5 Other monitoring functions that can be activated

Monitoring additional voltage/frequency thresholds when switching on or switching on again

Some individual grid codes specify that when switching on or switching on again, before the operating enable, the voltage and/or the frequency must be additionally checked.

While the test is being conducted, it is monitored that voltage and frequency thresholds are complied with.

For a regular switch-on operation, the test duration is set using p5545[6], For an automatic restart, a separate test duration is entered (p5545[7]).

5.3.4 Cosinus phi display function module

Background

Active Line Modules have, in the basic configuration, the smoothed power factor available as a display variable (r0038).

In this case, power factor λ is defined as quotient

$$\lambda = \frac{|P|}{S}$$

However, grid codes and technical directives for power generating units also specify that the displacement factor (also: $\cos\varphi$) is evaluated.

Contrary to the power factor, the displacement factor is defined as

$$\cos \varphi_1 = \frac{P}{S_1}$$

The basic fundamentals of the voltages and currents are used as basis to calculate the apparent power S_1 (just the same as for the active power according to the definition). If the harmonic reactive power is not equal to zero, then the following applies: $\lambda < \cos\varphi_1$, and the power factor indicated in r0038 is poorer than the actual $\cos\varphi$.

Further, generally, the displacement factor for the connection point of the complete system must be specified. For example, for an upstream transformer, this point can differ electrically from the connection terminals of the line filter, which are used as basis for r0038.

The "Cosinus phi display" that can be optionally activated, allows the calculation of the $\cos\varphi$ value to be flexibly configured.

Note

Definition, displacement factor $\cos\varphi$

Displacement factor $\cos\varphi$ is also defined as the cosine of the phase angle φ between the sinusoidal oscillations of the voltage and the current having the same frequency. For a more precise designation, an index is therefore added corresponding to the particular frequency or harmonic number.

The VSM10 measures voltages and currents, so that these variables (and not power) are used as input signals for the $\cos\varphi$ display.

Note

Defining the sign

The definition of the sign as generating unit matches the use in the grid standards (e.g. VDE-AR-4105).

- For underexcited operation (negative reactive current: $r0076 < 0$) the following applies:
Lower output voltage or lagging current is designated with a positive sign.
 - For overexcited operation (positive reactive current: $r0076 > 0$) the following applies:
Higher output voltage or leading current is designated with a negative sign.
-

5.3.5 Additional closed-loop controls function module

5.3.5.1 Reactive current/apparent current limits

Background

Using current limits, the operating behavior of the Active Line Module can be adapted to address the requirements of an application. Current limits are available for various current types, operating states and parameter types.

The following differences apply:

- **Active current**
Percentage grid current that is in phase with the grid voltage and which results in an active power exchange between the load connected to the DC link and the grid.
- **Reactive current**
Percentage grid current with a phase shift of 90° to the grid voltage. A reactive current results in a voltage drop across grid inductances and capacitances, as well as losses in the ohmic components of the grid impedance. However, the reactive current is not involved with exchanging power between the load connected to the DC link and the grid.
- **Apparent current**
The vectorial sum of the active current and reactive current results in the total current called the apparent current. Limiting the current amplitude in each line phase corresponds to apparent current limiting.
- **Negative sequence system current**
In the case of unsymmetrical 3 AC currents (different amplitudes in the grid phase arms), it is possible to mathematically break down the currents into positive sequence system in synchronism with the grid voltage (basic fundamental of active and reactive current) and a current vector rotating in the opposite direction (what is known as the negative sequence system).
For example, negative sequence systems occur for 2-phase line dips, and do not participate in the average value of the active power over a fundamental (frequency) period, but generate power harmonics with twice the grid frequency.

Note

Definition of active power

The active power exchanged between the load and grid is defined as the integral of the product of voltage and current over one grid period. The instantaneous values for the currents (e.g. r0076, r0078) calculated by the closed-loop control, are not average values over a fundamental (frequency) period, but also include harmonic components.

Detailed descriptions of the function modules

6.1 Additional closed-loop controls for current-controlled operation

6.1.1 Background information

The following diagram shows the control structure of a grid inverter for feeding power into a power grid, together with a typical system configuration. The function blocks added to comply with the different global grid codes are marked in gray. However, it should be noted that the complete standards can only be complied with by considering the complete generating system as a whole, e.g. with a drive component, so that for a grid overfrequency condition, the active power can be reduced.

The control always operates in rotating active-reactive coordinates with the grid frequency; VDC controller and active current controller form a cascade structure. Using the Park transformation technique, the output voltages of the active and reactive current controllers are converted into space phasors with stationary $\alpha\beta$ coordinates or into phase voltages. A PWM modulator determines the switching operations of the grid inverter for the next pulse clock. The grid phase angle required for the Park transformation is calculated from the grid voltages using a PLL.

6.1 Additional closed-loop controls for current-controlled operation

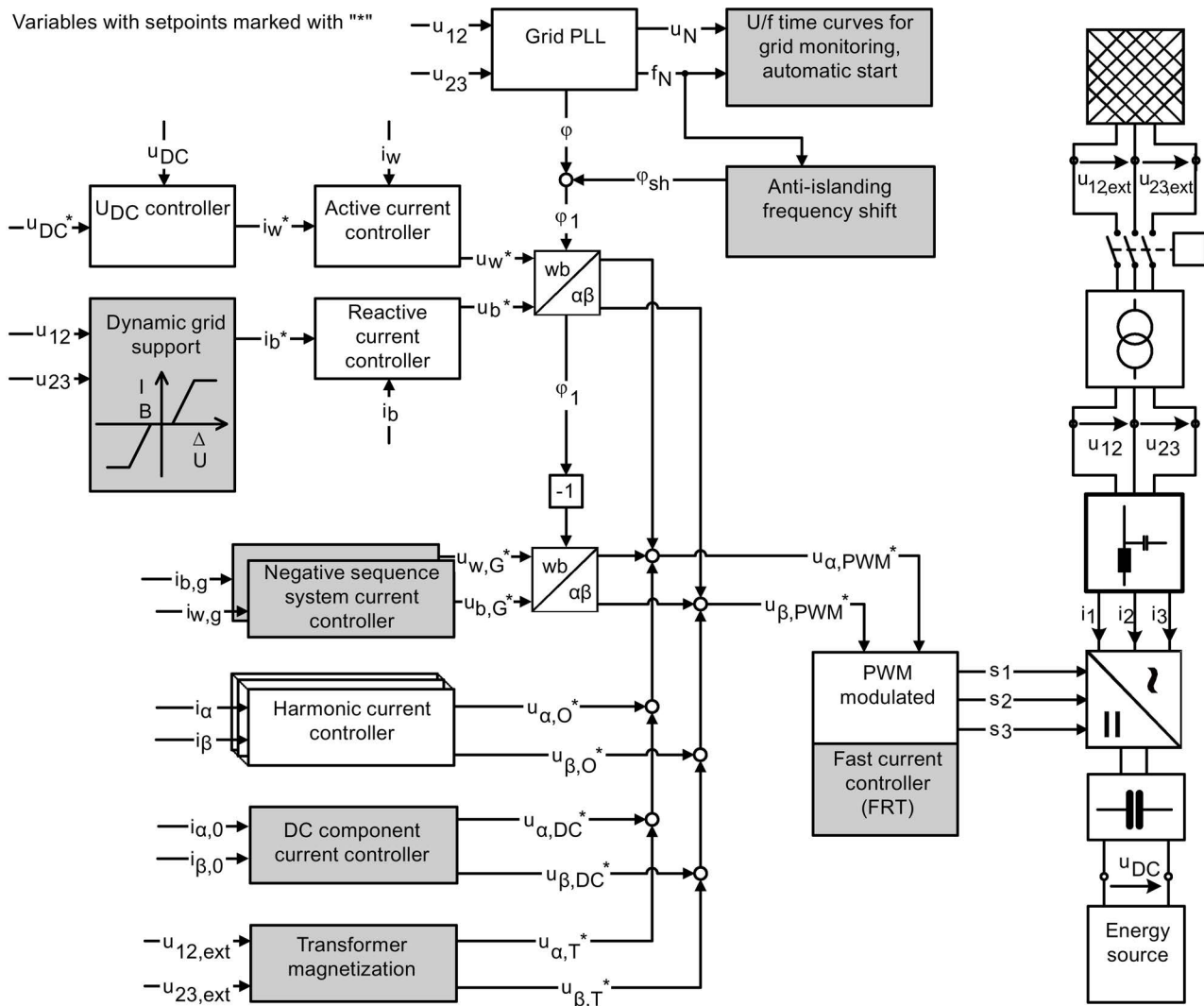

Figure 6-1 Additional modules for current-controlled operation

6.1.2 Dynamic grid support

Background

A parameterizable characteristic allows a reactive current to be specified corresponding to the deviation of the grid voltage from its rated value. This is specified in many grid codes. The background to this requirement is the inductive behavior of a grid inverter, whose most simple equivalent circuit diagram comprises a series circuit of a controlled voltage source and inductance L. Different voltage levels between the grid inverter and grid result in current flowing in the reactive axis due to

$$i_b = (U_{grid} - U_{inv})/j\omega L$$

Conversely, a reactive current results in a voltage change at inverter outputs u12, u23. The characteristic is selected so that the line voltage change is counteracted, therefore helping to stabilize the grid voltage (inverter acts as grid support element).

Application

The "Dynamic grid support" function module must be activated to use this functionality (p5500 to p5529).

The overall function comprises two subfunctions that are coupled with one another: On one hand, reactive current injection corresponding to the characteristic defined with p5505 and p5506, which can be configured to address the requirements of the local power utility company. The other subfunction involves the settings for fast current limiting when riding through low and possibly non-symmetrical line dips (FRT).

By specifying the signal sources for line current (p5503) and line voltage (p5504), the grid support function can be configured for various connection points of the power generation system. It is especially important to note that a connection point can be selected at the grid side of a connection transformer.

We recommend that configuration bit p5500.3 = 1 is set (default setting). Otherwise, generally current symmetry cannot be attained – especially during an unsymmetrical grid fault. During a grid fault, if active and reactive power injection are not required (Z mode) then the system can also operate in the mode p5500.3 = 0 without negative sequence system controller. This can be advantageous for difficult grid conditions (e.g. for grids with low system fault levels).

Generally, for grid voltage dips, it is not possible to transfer the available active power to the grid. As a consequence, the DC link voltage increases. Depending on the general conditions of the application, this increase can result in a fault trip due to DC link overvoltage if no countermeasures are taken on the power generating side. To prevent this and to reduce V_{dc} , when the V_{dc} threshold p5508[0] is reached, the active current has priority over the reactive current component. Correspondingly, when a V_{dc} threshold is fallen below (see p5508[1]), a motoring active current can be injected in order to prevent a pending shutdown due to an undervoltage condition.

Note

By dynamically limiting the grid currents (for example, see p3524, p3528, p3529, p5520) depending on the operating state of the grid support (r5502, r5522), the system can be adapted to address the specific requirements of individual grid codes.

6.1.3 DC component controller

Background

Especially when used in power generating systems, grid inverters must normally maintain extremely low limit values for the DC component in the phase currents.

Already low DC components can have a negative impact, for example on the operation of grid transformers ["Verfahren und Vorrichtung zur Ausregelung von Verzerrungen im Magnetisierungsstrom eines Transformators, der mit einem selbstgeführten Stromrichter mit abschaltbaren Leistungshalbleiterschaltern verknüpft ist", EP0896420, H. Weiss, Siemens AG]:

A DC current component in the phase currents shifts the magnetic operating point of a transformer. As a consequence, an unsymmetrical current characteristic is obtained in operation, where the dissymmetry depends very heavily on the amplitude of the shift. If a transformer is operated with the grid voltage, it is normally very highly utilized magnetically; this means that the magnetizing current already manifests visible symmetrical distortion. This distortion is symmetrical and only causes harmonics with uneven order numbers. If a DC current component is injected into the transformer, then even very low DC current amplitudes can result in a very high distortion of the magnetizing current. For modern transformers, the limit values for DC components may only be a per mill of the rated AC current. This distortion is no longer "hidden" in the generally very high primary current, but instead generates very high magnetizing current spikes, which then visibly impact the primary current. The effects range from noise as a result of the electromagnetic current forces, through harmonics in the output voltage with even order numbers up to insulation faults as a result of high voltage peaks occurring across resistances and/or inductances.

Already standard active and reactive current controllers significantly reduce the DC components in AC currents through the proportional element, therefore guaranteeing reliable and straightforward operation of converter transformers.

Further, in order to satisfy the requirements of the grid codes – also without connection transformer – a dedicated additional controller is available to compensate any remaining DC components.

It is worth noting that a DC component in the phase currents should not be confused with what is known as a zero component when breaking down three-phase currents into symmetrical components. The latter does not involve a DC component when generating a mean value over one line period (in an individual conductor), but involves a current component, which flows with the same phase in all 3 conductors – and that returns, e.g. via a ground conductor.

Application

The "Line transformer" function module must be activated in order to use the DC component controller (p3648 to p3654).

The controller is activated by selecting the proportional gain $p3650 > 0$. The value $p3650 = 100 \%$ corresponds to the recommended default setting for a correctly set magnetizing inductance of the transformer (p5492).

When the magnetizing inductance of the transformer is not known (type plate, data sheet), then the magnetizing inductance can also be measured (p5480 = 11). It should be taken into account that the identification result r5491, especially for transformers with low magnetizing current (large magnetizing inductance L_H) is very sensitive with respect to disturbing quantities. The reliability when determining L_H can be improved by separately sensing the filter currents using a VSM10 (r3671, r3672). To do this, filter monitoring must be activated using p3678 > 0.

If there is any doubt regarding the validity of the set magnetizing inductance p5492, then we recommend that the gain of the DC component controller is set to somewhat lower values (e.g. p3650 = 30 %), to avoid any instability.

Note

The DC component control increases the computational load and reduces the ruggedness of the control, as additional natural resonance effects occur. As a consequence, the controller should only be activated when required.

6.1.4 Negative sequence system current controller

Background

In the case of unsymmetrical grid faults or voltage dips, some grid codes specify that symmetrical grid currents should be injected, i.e. the same current amplitude in all three grid phases. In conjunction with a fluctuating grid voltage, this automatically results in a power oscillation, where the DC link capacitor is used as energy buffer.

The current is firstly broken down into symmetrical components, where each 3-phase system can also be defined with complex amplitudes for a zero component, a positive sequence system and a negative sequence system. In the time domain, the negative sequence system corresponds to a vector rotating in the opposite direction, i.e. a coordinate transformation with a negated grid phase angle $-\varphi$.

For a negative sequence system setpoint of "0", the controller modulates the converter output voltage with a signal component at twice the grid frequency, so that a symmetrical 3-phase current is obtained. By suitably entering negative sequence system current setpoints, when required, individual grid phases can also be supported. In fact, in an extreme case with identical positive sequence system and negative sequence system setpoints, a no current grid phase can be achieved.

Application

In the frequency spectrum of the phase currents, an existing negative sequence system is noticeable as a result of a frequency characteristic at twice the grid frequency – and possibly multiples of this. This current dissymmetry is corrected by activating the negative sequence system control (p3640 = 1) with a setpoint of zero (p3641). The gain of the negative sequence system controller corresponds to the gain factor of the standard positive sequence system current control, and therefore cannot be separately adjusted. On the other hand, the integral time can be adapted when required (p3639).

6.1 Additional closed-loop controls for current-controlled operation

In most applications, a setpoint other than zero does not make sense. During an FRT, a possibly required non-symmetrical support current is directly injected internally (p5509[8]). In the default setting of the dynamic grid support with p5500.3 = 1, the negative sequence system control is automatically activated, in order to guarantee current symmetry even for 2-phase grid faults.

A negative sequence system in the grid voltage or grid current is associated with power pulsations, which result in the corresponding oscillations in the DC link voltage. However, in order to dynamically control the average value of the DC link voltage (which is actually the decisive value), V_{dc} is suitably filtered using an adjustable bandstop filter (p3645).

Note

The negative sequence system control increases the computational load and reduces the ruggedness of the control, as additional natural resonance effects occur. As a consequence, the controller should only be activated when required.

6.1.5 Grid-friendly transformer magnetization

Background

If the primary side of the transformer represents the system connection point, then when switching-in, a type of transformer pre-charging is required in order to avoid impermissible inrush currents and grid flicker. The function block uses the power available in the DC link to establish a voltage at the transformer terminals with the correct phase assignment. After this, the main switch can be closed in an almost no-current condition.

Application

Adapted transformer data must be specified (p5436, p5492) if the transformer model (r5497, r5498) is used, for example, for voltage control or a current DC component controller is active (p3650 or p5436). Transformer data identification is not required for pure transformer magnetization.

The transformer parameters (p5436, p5492) are appropriately preassigned for the relevant Active Line Module power rating. If no applicable data are available, or can be measured (also see Section "Current DC component controller"), then we recommend that the default values are kept.

If the pre-charging circuit of an application only generates a low DC link voltage, which is not sufficient to fully magnetize the transformer (modulation depth r0074 at its limit), then the target value for the magnetization can be reduced (p5494[0]). When closing the grid contactor, the residual magnetization required only creates a relatively low and generally permissible recharging current surge.

Typical signs of an excessively low V_{dc} are high phase currents as a result of operation with overmodulation (r0074 > 100 %).

The maximum current while magnetizing can be monitored in order to avoid overloading the precharging circuit (p5494[1]). This means that an attempt to magnetize an inadvertently grounded transformer can be canceled in a timely manner, for example.

The status is displayed in r5482 and r5499.

If a transformer is not being used, a 1:1 transformer can be parameterized (for example, to still be able to use other functions such as the DC component controller etc.).

6.2 Controls for grid droop operation

6.2.1 Background information

The subsequent diagram shows the principle, modular design of a power generating system based on the kinetic energy with the generator, converter system, line filter to reduce the pulse-frequency grid harmonics to comply with the applicable grid code and a grid transformer. By adjusting the magnitude and angle of the output voltage, inverters with 3 conductor connection without internal energy storage device (e.g. B6 bridges) have the ability to control two independent variables. These are used on the generator side, e.g. using subordinate current controls in dq coordinates for the flux and the torque/speed control. For the grid side, the currents differ corresponding to the active and reactive axes; the higher-level Vdc controller is used for the active current control. A specific $\cos\phi$ with respect to the grid can be set using the reactive current controller.

In a first approximation, in this configuration, the grid currents are impressed, independent of the grid state and the grid parameters. As a consequence, with respect to the grid, the power generating system behaves like a current source, whose power only depends on the power of the primary energy source. The grid converter continually follows the changing amplitude and frequency of the grid voltage. This principle of operation obviously requires a grid, which can absorb the instantaneous generated power at any time; further, it must control (closed loop) the amplitude and frequency. As a consequence, it is suitable for feeding into power grids.

These preconditions are violated when it comes to an island grid, if the power generating system reaches an excessively high percentage of the overall grid capacity (power rating). In this case, the behavior of a voltage source is required, which provides the instantaneously required load power with a defined voltage amplitude and frequency. The two degrees of freedom of the grid inverter are now required for these controlled variables. As a consequence, the inverter on the generator side must control the DC link voltage, therefore ensuring a balance between the generated and consumed power. The required Vdc controller uses, in a cascade structure, the torque controller; in this operating case, the speed control must be externally implemented as part of the actual application itself.

6.2 Controls for grid droop operation

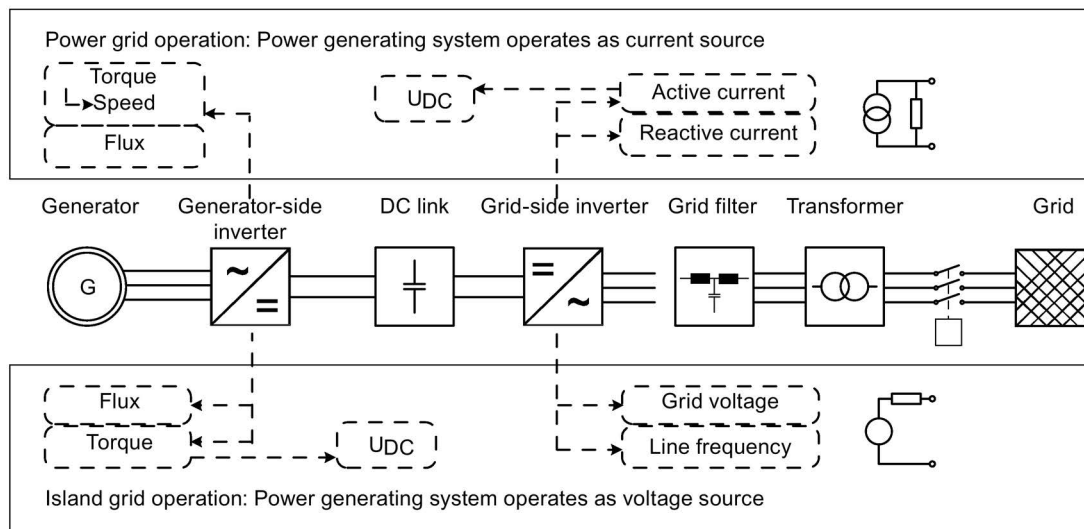

Figure 6-2 Basic control concept

Overview

In island grid operation, a generating system must play its role in maintaining the voltage and frequency (grid former). Stiffly impressing voltage and frequency would be conceivable using inverters. However, this would not facilitate stable, common operation with other power generating systems for a specific load distribution without the use of additional, complex communication.

For primarily inductive grids ($X \gg R$), from a general apparent power perspective for an electrical "two-port" between two grid connection points, a change of the voltage angle or the frequency especially influences the exchanged active power P ; on the other hand, the amplitude of the voltage influences the reactive power. As a result of the commutation inductances of the inverters and the inductive behavior of generators and many loads, the precondition $X \gg R$ can be assumed to be applicable in typical microgrids.

For the setpoints for frequency f_{droop} and amplitude U_{droop} , the following droop characteristics are applied to the inverter output voltage (see the following diagram):

- $f_{droop}(t) = f_0 - k_f p(t)$ with no load frequency f_0
- $U_{droop}(t) = U_0 - k_U i_b(t)$ with no load voltage U_0

Instead of the reactive power, for the voltage droop characteristic, reactive current i_b is used. This means that in the case of grid voltage dips (high reactive current, low reactive power), a sensible setpoint input is achieved. Typical values for characteristic gradients k_f and k_U are 3 %; however, these are very dependent on the specific application.

By smoothing the droop outputs, the behavior of rotating machinery is emulated to such an extent so that for mixed power generation involving generators and inverters, a stable, steady state grid is generated – as well as the required transition response for load steps in the grid. Time constant T_{f1} in the frequency axis corresponds to the mechanical inertia of a generator. The higher T_{f1} , the lower the frequency change at the start of a load step, which in turn means that the inverter system must initially provide more power. Using a fast supplementary droop T_{f2} a temporary frequency change can be implemented in order to avoid these types of power peaks. This results in a damping effect, which opposes any power oscillation in the grid. Using time T_U for the voltage axis, the inverter system can adapt

the generator inductances in the island grid. The downstream voltage controller ensures a steady-state accuracy of the voltage amplitude at the connection terminals, and therefore compensates the impedance of the inverter generating system.

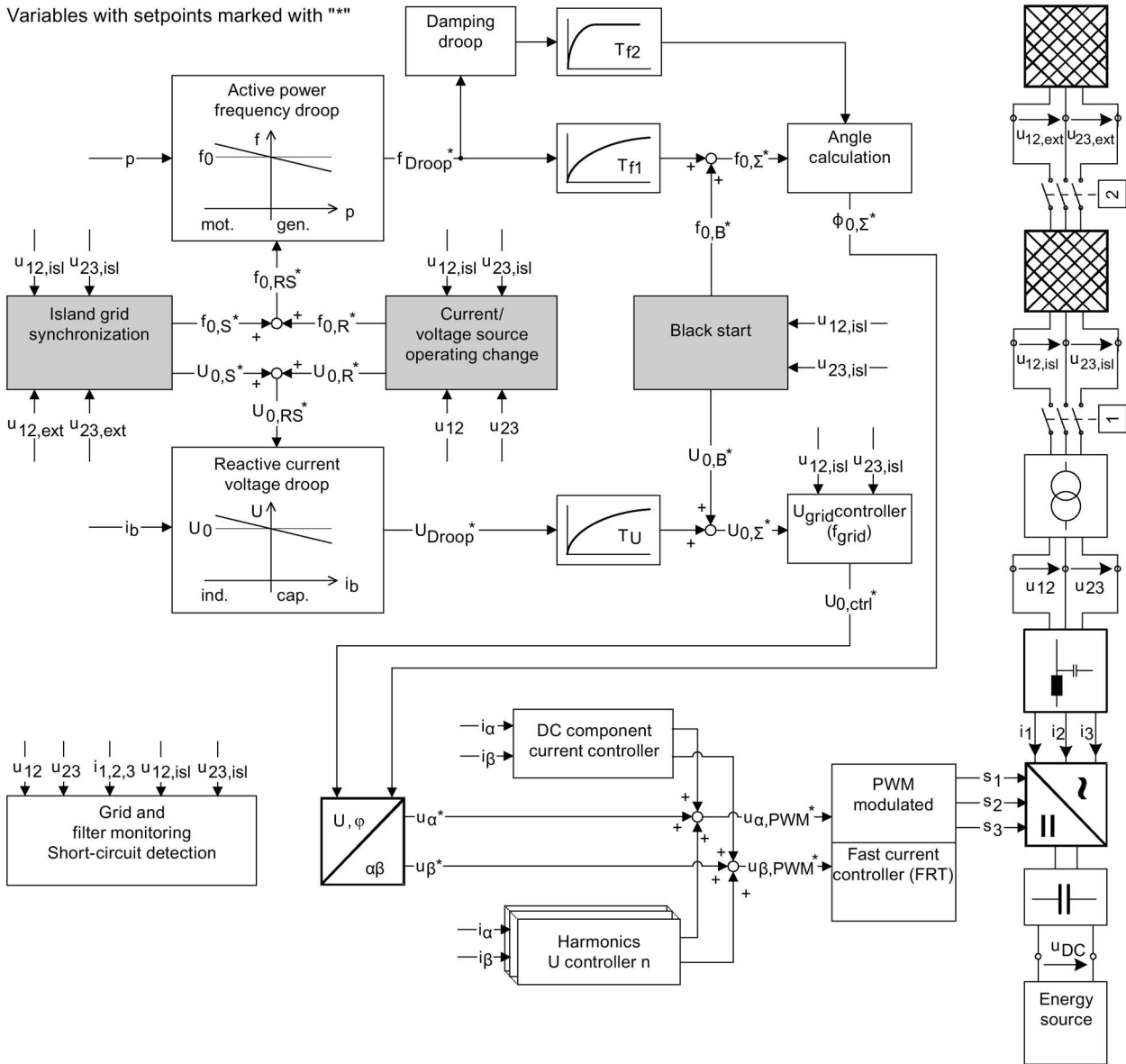

Figure 6-3 Grid droop control

Droop characteristics $f_{droop}(t)$ and $U_{droop}(t)$ represent proportional controllers for controlling the power balance between the generating units in a microgrid, and result in power-dependent and remaining deviations of the f and U setpoints. The necessary subsequent control of f_0 and U_0 to return to the rated f - U values after load changes, is not part of the control scheme shown here. This is the task of a higher-level power management system.

In grid forming operation, the currents are defined by the load. Currents with harmonics – e.g. as a result of non-linear loads – generate the corresponding voltage drops between the inverter and line connection point; these can be reduced using harmonic output voltage

6.2 Controls for grid droop operation

control. At the same time, a DC component controller suppresses possible DC fault components in the phase voltages, which would otherwise result in transformer saturation effects and power oscillations in the grid.

Providing high short-circuit currents to clear grid faults (trip fuses) is another important requirement placed on power generating systems. Here, a fast current controller allows (non)symmetrical grid faults for single generator operation – or together with other power generating sources – to be reliably ridden through (FRT). After a short circuit has been cleared, the power generating units are resynchronized without requiring any additional communication resources. For continuous, ongoing grid faults, after a defined time, a grid monitoring function shuts down and prevents short-circuit currents from being maintained when it comes to internal plant/system faults.

For use in microgrids, in addition to the power grid and island grid mode, all conceivable operating changes must be supported (diagram above, marked in gray).

- **Black start**

This function involves establishing the island grid voltage u_{12isl} , u_{23isl} starting from a voltage of zero, with disconnector 2 to the external grid open.

- **Island grid synchronization**

In operation, this function block adapts amplitude, frequency and phase position of the island grid voltage to an external grid u_{12ext} , u_{23ext} . Disconnector 2 can then be closed in an almost no-current condition, and coordinated by a higher-level management system – power can be exchanged between a micro grid and power grid.

- **Operating mode change**

Also when disconnector 2 is open, it can make sense to switch over a power generating system from the voltage source mode into the current-impressing mode. For example, this applies if a sufficient number of grid formers is active so that individual regenerative power generators (for example, photovoltaic systems) can operate with their maximum power as a current source.

6.2.2 U-f droop control

Background

The load equalization (balancing) between the power generating units in the grid, which is required for stable operation at an operating point with common frequency and amplitude, is preferably realized using droop characteristics (see the following diagrams). The droop function can also involve smoothing elements (PT1) to allow the existing time constants to be adapted to the particular grid. For instance, the frequency of a power generating unit decreases with increasing power output.

Every power generating unit in the grid, which actively participates in maintaining the frequency and voltage, determines, using these characteristics, its actual setpoints for the output voltage and frequency. In the case of conventional power generating stations, this would be comparable with what is known as the primary control. For instance, if all of the power generating units have the same rated power and the same characteristics, then an f-U operating point is obtained in the grid, where all power generating units provide the same power to cover the required overall load. This therefore results in a symmetrical load distribution without requiring any additional communication between the power generating units.

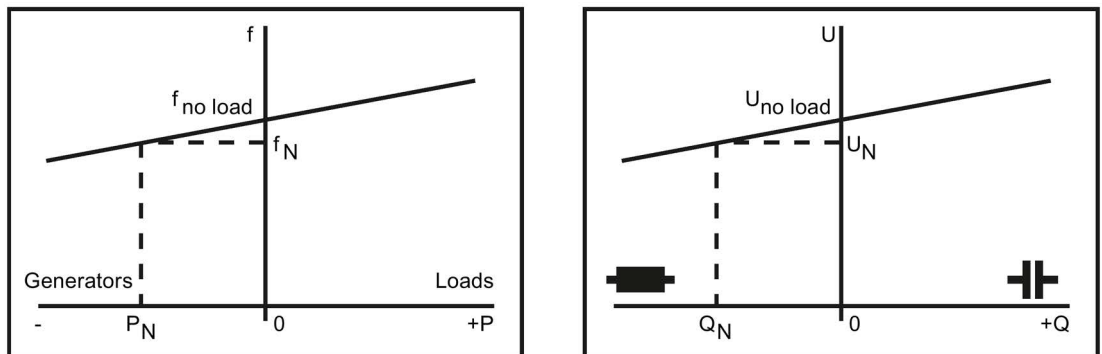

Figure 6-4 Active power droop characteristic and reactive power droop characteristic for frequency and voltage

The principle of operation can be explained using a simple example for the reactive power characteristic with 2 power generating units and a consumer load P_V (following diagram): For the output frequency of the first and second power generating unit, with k_1 and k_2 as characteristic gradients and identical no-load frequency f_0 , the following applies:

$$f_{E1} = f_0 + k_1 \times P_1, \dots, f_{E2} = f_0 + k_2 \times P_2.$$

For the condition for the sum of powers $P_1 + P_2 + P_V = 0$, for the frequency of the second power generating unit, the following dependency on the power of the first power generating unit is obtained:

$$f_{E2} = f_0 + k_2 \times (-P_1 - P_V).$$

As a consequence, the characteristic of the second power generating unit can be mirrored – and shifted by P_V – entered in the P-f diagram of the first power generating unit in order to show the resulting operating point with common frequency f_A . The first power generating unit participates with P_{E1} in the overall power required.

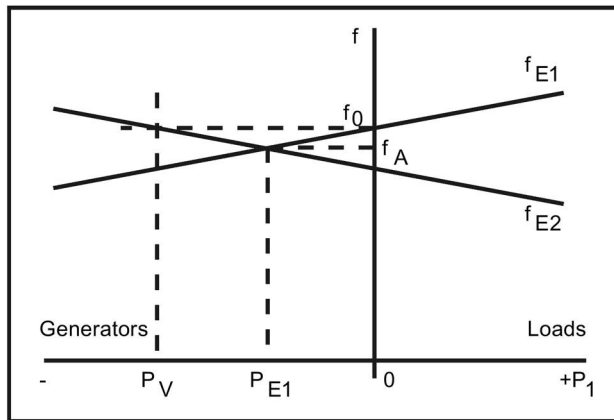

Figure 6-5 Common operating point of several power generating units in the grid

Typically, the primary control in grids is a fast P control, which cannot control system deviations down to zero. Steady-state accuracy is achieved using slow higher-level, secondary controls. These shift the no-load points of the droop characteristics so that the rated grid frequency is reached as average value. To achieve this, it may be necessary to manually switch-in additional power generating units.

Application

The "Grid control" function module must be activated in order to use the "U/f droop control" functionality (p5400 to p5479).

- Suitable droop settings for the no load frequency p5405, no load voltage p5415 as well as the gradients of characteristics (p5407, p5417) must be entered for the particular application. In a grid with several power generating units, the energy management for the island grid can assume this task, for example. BiCo signal sinks for synchronous setpoint inputs are available for this purpose.

If an island grid is operated with only one power generating unit, then the gradient of the droop characteristics can also be set to 0.

Typical gradients for operation with several power generating units lie in the 3 % range. Excessively high gradients result in high frequency and voltage fluctuations. This can lead to stability problems in the grid, especially if additional self-commutated inverters are operated in this grid in the current controlled mode. The reason is that they cannot follow these grid fluctuations fast enough.
- Using signal sinks p5403 and p5404, the actual values for grid current and voltage are defined, which are used to calculate the droop input variables – i.e. active power and reactive current. The output variable of the voltage droop is the voltage at the inverter terminals. The load currents result in voltage drops across the impedances between the inverter and the connection point of the power generating system (for instance, at the line filter of an upstream transformer). The additional voltage controller p5425 is used to compensate these voltage drops, and to set the voltage setpoint according to the droop at the required interconnection point. Integration time p5427 of the voltage controller is typically selected to be higher than the smoothing time p5419 of the droop function.

- The harmonic content of the output voltage depends very heavily on the modulation depth $r0074$, i.e. the ratio of the voltage at the AC terminals of the inverter with respect to the DC link voltage. Optimum grid harmonics are obtained at approx. $r0074 = 94\%$. The harmonic content increases when the output voltage changes with the DC link voltage remaining constant. Using the supplementary setpoint $r5433$ for the DC link voltage controller (e.g. $\{VECTOR\}p3511 = \{ALM\}r5433$), the harmonic content can therefore be optimized depending on the operating point.
The modulation depth is not limited in the default setting. As a consequence, especially in the overmodulation range ($r0074 > 100\%$) significant current components can occur, even with low grid harmonics. Limiting the modulation depth with $p5432[1]$ can prevent this happening. In the case of overmodulation, limiting the output voltage results in an increased reactive current with the basic fundamental frequency corresponding to the U droop characteristic.
- Especially for non-linear loads in the grid, low grid frequency harmonics (especially the 5th and 7th) of the output voltage, caused by harmonic currents in the internal impedances of the power generating system, are reduced. It is activated using $p5440$.
- Using $p5401[0]$, it is possible to change between normal current-controlled operation (the Active Infeed Module is then mostly assigned to the DC link voltage control) and droop operation as voltage source. This change can be made in operation at any time. When switching from closed-loop current control to grid control it should be ensured that the set droop parameters match the instantaneous line frequency and amplitude. Otherwise, high active and reactive powers are obtained corresponding to the droop. When changing from grid control to current control it should be observed that during a transition ramp, the no-load points internally shift the droop, so that the transition can be carried out in an almost no-power condition. For this short transition time, it is possible that other power generating units in the island grid provide consumer loads. Such a change is always possible if an island grid is connected with an external power grid, or if other, sufficiently powerful power generating units can ensure that the frequency and voltage are maintained.
- When required, the droop characteristics can be enabled or inhibited using $p5401[1]$. For active grid control ($p5401[0] = 1$), but with the characteristics inhibited, the no-load points are continually internally adapted to the grid so that over the average, the power generating unit is operating under no-load conditions. However, in turn, other power generating units must control the grid frequency and amplitude. For instance, this function can be used to very simply implement a hot standby function for the power generating system. When a fault occurs, the system can supply the grid without any interruption. Further, the characteristic inhibit can be used to already change into droop operation, even without correctly adapted droop parameters (no-load points, gradients); the suitable droop settings can then be made afterwards.
- When activating the grid control, the V_{dc} control must be realized using another DC link component. For example, this can be a battery buffering system or PV modules. For drive applications, V_{dc} control using a motor inverter is typical. Status signal $r5402.0$ can be connected, for example, to the inhibit input of the V_{dc} controller $p3513$ in the vector drive object.

Note

Regarding the current limits (e.g. for heavy-duty drive starting, when transformers are switched-in as well as for grid short-circuits) with p5478, see Chapter Commissioning active, reactive and apparent current limiting (Page 132).

6.2.3 Damping power oscillations

When several power generating units operate in a grid, power oscillations and undesirable power peaks can occur.

For example, in the case of a step-like increase in the active load in the grid, that power generating unit can quickly take over the main load whose frequency remains the highest or which manifests the lowest dip. While rotating generating equipment (generators) manifest a speed dip, at least temporarily, inverters can maintain the output frequency constant, even when maximum load changes are involved. However, this would result in undesirably overloading the grid inverter.

During these types of load changes, in order to guarantee a uniform power distribution between the power generating units, PT1 elements p5409 and p5419 are used to emulate the basic transitional behavior of rotating machinery. The higher that these time constants are selected, the "stiffer" the behavior of the Active Line Module as power generating unit, and the higher the load peaks at the Active Line module (while "softer" generating units in the same grid are temporarily relieved). Therefore, higher values for p5409 correspond to generators with a high moment of inertia or a high flywheel mass. As a consequence, time parameters should be adapted to the time response of the other generating units in the grid.

Power oscillations between the power generating units can also occur without load changes as a result of consumers connected to the grid, if the grid parameters and the droop settings result in an unstable operating point.

To secure the grid stability in the case of several power generating units in the grid, we urgently recommend setting as a minimum, a damping option for the droop control:

- Using the fast supplementary droop p5413, the frequency dip of a generator is emulated using the setpoint of the grid droop, which occurs in the case of a load step. This can be converted into a differentiating component of the control, and significantly increases the control loop damping (p5413 = 50 % ... 100 %).
- Alternatively, or when required, the droop controller can be supplemented by an explicit DT1 arm (p5476 = 50 % ... 100 %).

6.2.4 DC component controller

Application

Regarding the background information, please refer to the section on the DC component control in current-controlled operation, see DC component controller (Page 52).

Contrary to this, the DC component control in the grid controlled operation is generally mandatory, especially if the island grid contains transformers. (In current-controlled operation, the basic frequency current control already ensures adequate compensation of the DC component)

The controller is automatically preset. A transformer with typical data and a power rating approximately the same as the Active Interface Module is assumed. If this assumption does not apply, then the main transformer inductance p5492, total resistance p5436 and controller integration time p5437 must be appropriately set (also refer to the parameter descriptions). If data sheet data is not available, the magnetizing inductance can be measured using an identification run. Please refer to the section on the DC component control in current-controlled operation.

Note

Unsuitable settings of this DC component controller (especially excessively high control gain p5436) can result in instability of the complete grid control.

6.3 Supplementary functions

6.3.1 Grid voltage sensing using an additional VSM10

Additional voltage measured values are required for many applications in the area of forming island grids, corresponding to the "Grid control" diagram. The "Grid transformer" function module supports the evaluation of up to 2 additional VSM10 devices.

Voltages u12/u23 are detected by the VSM10 included as standard for Active Interface modules, chassis format. In the case of a parallel ALM/AIM circuit, it should be noted that each of these parallel components includes a VSM10; an average measured value is calculated and is considered here as a single, effective VSM10. The administration parameters are available from p0140ff. (For power generating applications using Active Line Modules, booksize format, a VSM10 connected to the Active Interface Module is specified.)

When the "Transformer magnetization" function is used, voltages u12_{isi}/u23_{isi} must be sensed using an additional VSM10. We recommend that this VSM10 is used for the grid droop control, in order to guarantee that the droop characteristics are precisely maintained. When required, instead of this, the voltages can be also calculated using the transformer model (r5498).

However, errors in the model parameters then automatically result in incorrect voltage values and deviations in the power distribution in the island grid involving several power generating units.

6.3 Supplementary functions

The administration parameters for this can be found starting at p0150[0]ff, the VSM measured values are then available in index 0 of parameter p5460.

Voltages $u_{12_{ext}}/u_{23_{ext}}$ must be sensed using an additional VSM10 if the "Island grid synchronization" function is to be used. The administration parameters for this are available from p0150[1]ff; the VSM measured values are in index 1 of parameter p5460.

6.3.2 Transformer model and identification

In addition to having a specific ratio, other significant properties of transformers include introducing a phase shift, having a leakage inductance (results in a voltage drop) as well as a magnetizing inductance; this is decisive for the magnetizing current and setting the DC component control.

The precise ratio and the phase shift are of significance for the transformer magnetization function. Both data can be taken from the transformer data sheet, and must be set as precisely as possible in p6420[0] and p6421[0]. With p5480 = 12, a fine measurement can be performed (display in r6440, r6441), so that, with the optimum settings, equalization currents are minimized when closing the grid contactor (see the diagram in Chapter Commissioning example of an infeed with dynamic grid support for a power grid (Page 86)).

Further, with p5480 = 13 – in conjunction with the grid identification p3410 = 1 – the transformer leakage inductance can be determined (r5489). To repeat a measurement, p5480 must first be set to 1, and then set back again to a value of 13. It is important that p5490 is precisely set if, for example, for functions such as the grid voltage control, the transformed VSM measured values (r5488) of the transformer primary side are not used, but instead calculated based on the results of a model (r5498).

For the island grid synchronization function, the corresponding parameters p6420[1] and p6421[1] must be set for a transformer between the island grid and external grid. An automated measuring routine is not available here. It is important that the parameters define the voltage relationships between the Active Interface Module and the external grid. This special means that in the case that transformers are connected in series, the phase shifts are added, and the ratios must be multiplied.

With test modes p5480 = 101, 102, operation of the power generating system can be tested with the circuit breakers open and without a connection to the grid.

6.4 Back-to-back operation of Active Line Modules

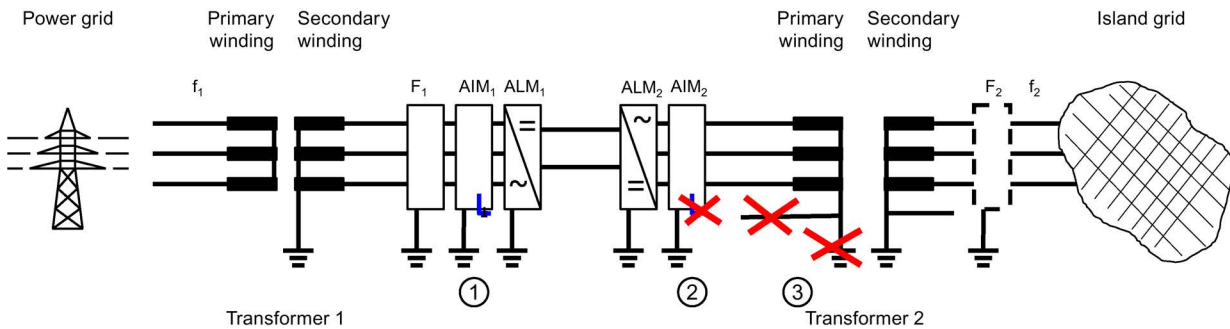

- f_1 Frequency of the power grid
- f_2 Frequency of the island grid
- F_1 Line filter of the power grid
- F_2 Line filter of the island grid

Figure 6-6 Back-to-back operation - diagram showing the principle of operation

Back-to-back operation of Active Line Modules designates the connection between two Active Line Modules in a DC link. In this case, the DC link is supplied from an Active Line Module (ALM_1), the ALM_2 generates a decoupled grid (regarding voltage and frequency). On the AC side, the two Active Line Modules are operated in two separate grids. Typical applications include the supply of island grids from the public power grid as well as establishing back-to-back station couplings (e.g. for frequency conversion). Inadmissible ground connections between the two separate grids (e.g. via capacitively grounded neutral points) result in overcurrents, instability and overvoltages, which can also damage other grid components (e.g. power supply units).

Further, it is not permissible that there is any other low ohmic ground connection between the AC connection of the Active Line Module at the island grid and the primary of an island grid transformer (e.g. no neutral point grounding). This is also especially true for capacitive connections of the PE conductor to the grid neutral point. As a consequence, in most situations, the grounding bar of the Active Interface Module must be removed when used in an island grid.

A typical configuration with 2 Active Line Modules (first Active Line Module in the supply grid, DC link, second Active Line Module for forming the island grid) can therefore look like this:

- Line filter of the first Active Line Module (supply grid) with grounding bar in the Active Interface Module (①).
- Line filter of the second Active Line Module (island grid) without grounding bar in the Active Interface Module (②).
- Further, it is not permissible that there is any other low ohmic ground connection between the AC connection of the Active Line Module at the island grid and the primary of an island grid transformer (e.g. no neutral point grounding between the Active Line Module and the island grid transformer, ③).
- It is permissible to ground the neutral point at the secondary of the island grid transformer (e.g. neutral point grounding of the transformer, connecting EMC filters with respect to ground, etc.).

Commissioning

The functions for grid infeed as well as island grid operation were described in the previous chapters. Reference was also made to the parameter settings required.

The steps obtained for commissioning typical system configurations are shown in tabular form based on two application examples. Individual aspects are then separately discussed, for example setting transformer parameters.

7.1 Safety notices

 WARNING
Danger to life if the fundamental safety instructions and remaining risks are not carefully observed
If the fundamental safety instructions and remaining risks in Chapter 1 are not observed, accidents involving severe injuries or death may occur.
<ul style="list-style-type: none">• Adhere to the fundamental safety instructions.• When assessing the risk, take into account residual risks.

7.2 Preconditions

Hardware

- Control Unit CU320-2 PN or CU320-2 DP
- Active Line Module, booksize format with article number ...AA3 or chassis format with article number ...AA4 with associated Active Interface Module
- Application-dependent number of Voltage Sensing Modules (VSM10) to measure voltages
- DC voltage supply for the DC link, e.g. Motor Module, for rotating power generation using a generator, or battery

Software

- STARTER with Version 4.4 or higher
SSP for SINAMICS V4.7
- SINAMICS S120 firmware version 4.7 or higher
- Memory card for CU320-2 with one of the options:
 - Booksize device:
Licensing corresponding to the power rating and application
 - Chassis format devices:
S01: Dynamic grid support for feeding power into a power grid
S02: Grid control for feeding power into an island grid

Hardware to be supplied on-site

- Transformer
- Line contactor
- Generator

7.3 Basic commissioning

When commissioning offline with the STARTER, you must select the infeeds on the basis of their article numbers.

7.3.1 Infeed units in the chassis format

Table 7- 1 Article numbers for infeed units in the chassis format for grid voltages 3 AC 380 ... 480 V

Active Line Module	Grid voltage	Rated power at 3 AC 400 V	Rated infeed/regenerative feedback current
6SL3330-7TE35-0AA4	3 AC 380 ... 480 V	300 kW	490 A
6SL3330-7TE41-0AA4	3 AC 380 ... 480 V	630 kW	985 A
6SL3330-7TE41-4AA4	3 AC 380 ... 480 V	900 kW	1405 A

Table 7- 2 Article numbers for infeed units in the chassis format for grid voltages 3 AC 500 ... 690 V

Active Line Module	Grid voltage	Rated power at 3 AC 690 V	Rated infeed/regenerative feedback current
6SL3330-7TG41-0AA4	3 AC 500 ... 690 V	1100 kW	1025 A
6SL3330-7TG41-3AA4	3 AC 500 ... 690 V	1400 kW	1270 A
6SL3335-7TG35-8AA4	3 AC 500 ... 690 V	630 kW	575 A
6SL3335-7TG41-3AA4	3 AC 500 ... 690 V	1400 kW	1270 A
6SL3335-7TG41-6AA4	3 AC 500 ... 690 V	1700 kW	1560 A

7.3.2 Infeed units in the booksize format

The technical data of the infeed units in the booksize format can be taken from the appropriate manuals.

7.4 Commissioning example for an infeed with voltage and frequency control for an island grid.

7.4.1 Design

Generator plant

In the example, the electrical power generated by a rotating generator is fed into an island grid. The island grid can be supplied from several power generating systems.

The generator is driven by a motor or a turbine. Examples for sources of energy are biogas, solar energy (solar thermal), natural gas, diesel, or hydro-electric power.

Block diagram

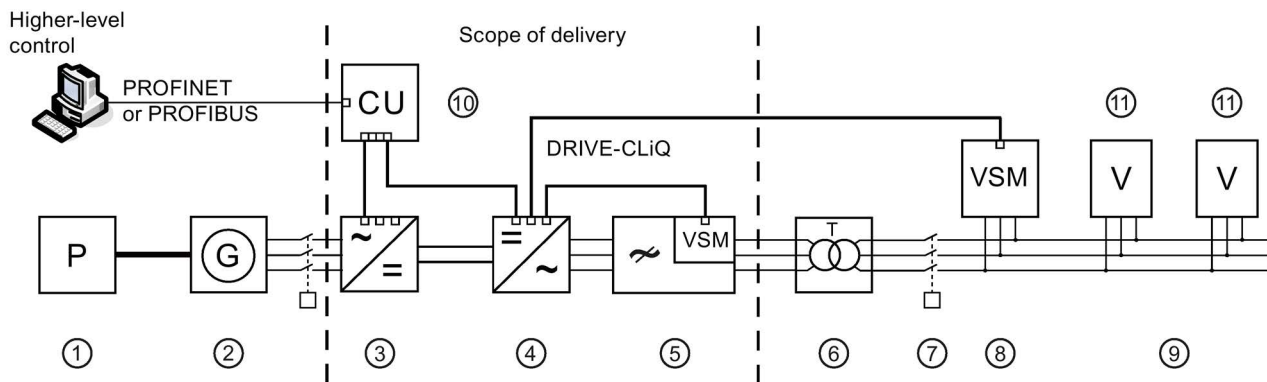

Figure 7-1 Infeed to a island grid via a generator

Table 7- 3 Components for infeed into an island grid via a generator

Number	Description
1	Driving machine (turbines, blade wheel, etc.)
2	Generator
3	Motor Module
4	Active Line Module
5	Active Interface Module with integrated Voltage Sensing Module VSM10
6	Grid transformer
7	Circuit breaker
8	VSM10 Voltage Sensing Module for measuring the line voltage on the primary side of the grid transformer
9	Island grid (low voltage)
10	Control Unit
11	Consumers

7.4.2 General information

Commissioning procedure

The following procedure is used to commission an Active Line Module for an island grid offline.

The Active Line Module should participate in the frequency and voltage control of the island grid.

In this case, a generator is used as an example to generate the power.

1. Create project.

2. Create drive units.

The drive unit for feeding into the grid is called INFEED.

The drive unit to control a Motor Module is called MOTORINVERTER.

3. Activating the function modules on the MOTORINVERTER drive device:

- Activate the "Technology controller" function module; when required, also the "Extended messages/monitoring functions" function module.
- Select the control mode "n/M control + U/f control, I/f control".

4. Activate the function modules on the INFEED drive device (see Chapter Function modules for creating a line infeed in an island grid (Page 72)).

5. Create additional VSM10 for measuring the grid voltage on the primary side of the grid transformer (No. 8).

6. If required, create an additional VSM10 to measure the power grid voltage for the "Synchronize island grid to an external grid" function.
Also refer to Synchronizing an island grid to an external power grid (Page 114).

7. Adapt the topology and the VSM10 assignments.

8. Perform additional parameter settings in the expert list.

To do this, the sequence of the individual sequential steps for identification and setting of the transformer data must be taken into consideration (see Commissioning grid-friendly transformer magnetization (Page 102)).

For weak networks (large inductance and low short-circuit power), additional recommended settings apply (see Notes for commissioning systems for operation on grids with low short-circuit power (fault level) and variable grid parameters (Page 138)).

Note

Description of the commissioning process

The basic steps when commissioning a SINAMICS S120 are contained in the Commissioning Manual.

Note

Access level

Some of the parameters to be set are accessible only under access level 4 (Service). This access level is protected by password. Only authorized persons will receive the required password within the scope of expert training provided by Siemens.

7.4.3 Function modules for creating a line infeed in an island grid

In the project, click on "INFEED" under "Infeeds" and then select "Properties...".

- Under the "Function modules" tab, select the "Grid transformer" and "Grid droop control" modules, and when required, select additional modules.

Note

Activation of the function modules by a higher-level control system

The function modules can also be activated by a higher-level control system. For this purpose, parameter p0009 of the Control Unit must be set to "2" (defining the drive type function module). You can then use parameter p0108[x].y = 1 of the Control Unit to activate the individual function modules.

In this case, the object number of the INFEED must be used for the index "x".

The meanings of the "y" bits for the function modules for grid infeed are as follows:

- (Bit 03 = supplementary controls)
- Bit 04 = grid transformer
- (bit 07 = dynamic grid support)
- Bit 12 = grid droop control

The function modules are activated with p0009 = 0.

7.4.4 Creating an additional VSM10

If the drive device was commissioned with full DRIVE-CLiQ topology using an automatic configuration, then the VSM10 modules are already in the topology. In this case, the number should not be changed, but the assignment checked corresponding to the following chapter, and if required adapted.

Procedure if the project was configured offline

In the project, double-click on "INFEED" under "Infeeds" and click on "Wizard..." in the configuration window.

- Do not change anything in the first screen.
- Select "Number of VSMs:" in the second screen in the list box Select as required. A VSM is entered in the "Number VSM" for each Active Line Module; this number of VSMs must be incremented by 1 to create an additional VSM10.
- Click through the remaining screens without making changes and close the wizard.
- This adds an additional VSM10 to the topology.

7.4.5 Adapting the topology and the VSM10 assignments

Double-click on "Topology" in the project; the topology view appears.

The topology looks like this after the above commissioning steps, for instance:

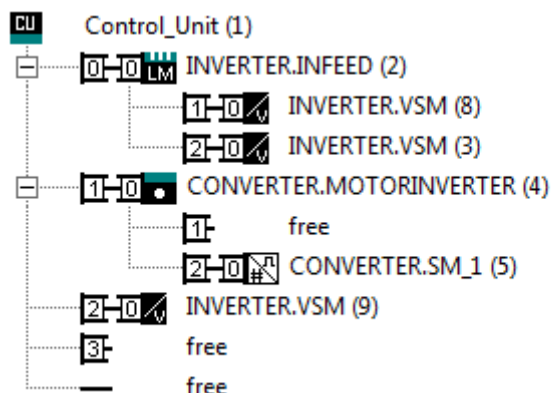

Figure 7-2 Topology

The numbers in brackets to the right of the components in the topology view are the "Component numbers".

- The VSM10 for the closed-loop control functionality of the infeed must be connected to the -X402 DRIVE-CLiQ socket (booksize format: -X202) of the INFEED infeed.
- The VSM10 for synchronization with the power supply (on the primary side of the grid transformer) must be connected to the -X401 DRIVE-CLiQ socket (booksize format: -X201) of the INFEED drive.
- The optional VSM10 for synchronizing to an external grid, must be connected to a free DRIVE-CLiQ socket of the Control Unit.

You must use the expert list to check the assignments of the VSM10 components present in the project and correct these where necessary.

The following settings refer to the topology shown above.

- The VSM10 with component number 3 is responsible for the closed-loop control functionality of the infeed.
INFEED.p0140 = 1 (access level 4)
INFEED.p0141[0] = 5 (access level 4)
- The VSM10 with component number 8 is responsible for synchronizing the infeed with island grid (VSM2 functionality).
INFEED.p0150 = 2 (access level 4)
INFEED.p0151[0] = 8 (access level 4)
- The VSM10 with component number 9 (when required) is responsible for synchronizing the infeed with an external grid (VSM3 functionality).
INFEED.p0150 = 2 (access level 4)
INFEED.p0151[1] = 9 (access level 4)

Note

Parameters p5460[0]...p5474[0] are responsible for the VSM2 functionality.

Parameters p5460[1]...p5474[1] are responsible for the VSM3 functionality.

7.4.6 Performing additional parameter settings in the expert list

The following table provides an overview of the most important adjustable parameters with typical values and notes for an island grid application.

This overview should provide help when commissioning the system. It does not replace the information in the previous chapters or the parameter descriptions and function charts in the List Manual.

Depending on the application, in individual cases, it may be necessary to change parameters, which are not listed in the tables.

Parameter settings for "INFEED" drive unit

In the project, right click on "INFEED" under "Infeeds" and then select "Expert list".

Table 7- 4 Parameter settings for "INFEED" drive unit

Parameter	Value	Comment
p0210	e.g. 400 V or 690 V	Enter the grid-side connection voltage for the grid converter Rated voltage at the generator side of the transformer/at the connection point of the Active Interface Module.
p0840[0]	e.g. INFEED.r2090.0	BI: On/Off1 via PROFIdrive PZD1, bit 0 Switch-on command for the Active Line Module or the beginning of the DC link precharging
p0844[0]	e.g. CONTROL_UNIT.r0722.0	BI: 1.OFF2 in CDS 0 via DI0 (-X122.1) of the Control Unit Signal sink for the OFF2 command of the Active Line Module
p0852[0]	e.g. fixed value 1	BI: Enable operation After p0840 = 1, without this operating enable signal, the Active Line Module would remain in the ready state after precharging has been completed. Further, the enable signal is required for transformer magnetization.
p0860	e.g. CONTROL_UNIT.r0722.1	BI: Grid contactor, feedback signal The feedback signal contact of the circuit breaker must be connected in order that the transformer magnetization function operates correctly. For this example, a connection is made to terminal DI1 (-X122.2) of the Control Unit.
p0861	e.g. 200 ms ¹⁾	Line contactor monitoring time Monitors activation/feedback signal from the generator switch. The value to be set depends on the switching times of the switch being used.
Pulse frequency wobulation		
p1810.2	Yes ¹⁾	Activate pulse frequency wobulation (access level 4) Wobulating (sweeping) the pulse of frequency ensures that the pulse-frequency voltage and current components are distributed over a frequency range. This makes sense if the distortion power at the individual frequencies should be reduced between 2 kHz and 9 kHz. This frequently applies to island grids.

7.4 Commissioning example for an infeed with voltage and frequency control for an island grid.

Parameter	Value	Comment
p1810.4	Yes ¹⁾	Inhibit wobulation (sweep) amplitude (access level 4) Depending on the filter being used: For standard Active Interface Modules: Yes Using this bit, the wobulation function is controlled for regular current-controlled operation (no grid droop operation). The "Yes" setting is recommended when using standard Active Interface Modules. In grid droop operation, the wobulation function is controlled using p5456. In the default setting of p5456 wobulation is activated (i.e. "Inhibit wobulation amplitude": No).
p1811	e.g. 5 % ¹⁾	Pulse frequency wobulation amplitude (access level 4) With a setting value of 5 %, regarding the pulse-frequency distortion powers, typical requirements placed on island grids are complied with.
DC link control		
p3410	0	Infeed identification method – identification (ID) off
p3415[0]	10,00 %	Infeed excitation current L identification – run 1 Amplitude of the measured currents for identifying the DC link capacitance For grids with low fault level (short-circuit rating), we recommend reducing the measuring current to 10 % (possibly down to 7 %) in order to ensure stable grid operation during the identification routine. See also: Notes for commissioning systems for operation on grids with low short-circuit power (fault level) and variable grid parameters (Page 138).
p3415[1]	10,00 %	Infeed excitation current L identification – run 2 Amplitude of the measured currents for identifying the DC link capacitance For grids with low fault level (short-circuit rating), we recommend reducing the measuring current to 10 % (possibly down to 7 %) in order to ensure stable grid operation during the identification routine. Run 2 is prevented by setting the same value as in p3415[0].
p3510	e.g. p0210 * 1.5	Infeed DC link voltage setpoint for 690 V 3 AC devices: 1035 V DC Normally, the setpoint should not be selected to be lower than 1.5x the grid voltage, as the control range for the current control would otherwise be limited too much, and current harmonics would occur. Upwards, the setpoint is limited by the maximum boost (step-up) factor p3508.
p3560	e.g. 50 %	Infeed Vdc controller proportional gain Note: Setting for soft networks (low short-circuit power)
p3603	e.g. 0 %	Infeed current pre-control factor D component can be increased by up to 50% for load surges in the event of a poor dynamic response of the controller. Note: Setting for soft networks (low short-circuit power)
p3615	e.g. 50 %	Infeed current controller P gain Note: Setting for soft networks (low short-circuit power)
Generator operation		
p5401[0]	e.g. INFEED.r2090.1	BI: Grid droop control activation – grid control activated via PROFIdrive PZD1, bit 1 For p5401[0] = 1, the Active Line Module switches from current-controlled operation to operation as voltage source (grid droop operation). The current is then no longer impressed, but is obtained from the connected load and the grid frequency and grid voltage characteristics.

7.4 Commissioning example for an infeed with voltage and frequency control for an island grid.

Parameter	Value	Comment
p5401[1]	e.g. 1	<p>BI: Grid droop control activation - static setpoint activation</p> <p>For p5401[1] = 1, droop characteristics p5405ff and p5415ff are active. For stable generator operation, the setting for the no-load points for voltage and frequency must match the actual operating point of the island grid (especially the load distribution between several power generating units).</p> <p>For p5401[1] = 0, the no-load points of the voltage and frequency droops must be internally corrected, so that on the average an apparent power of zero is obtained at the Active Line Module (parameters p5405/p5406 and p5415/p5416 are deactivated for the no load points).</p>
p5403[0, 1]	e.g.: p5403[0] = r5497[0] p5403[1] = r5497[1]	<p>CI: Line droop control current signal source</p> <p>If the droop is not to be active for the connection point directly at the Active Interface module, then observe the notes provided in the parameter descriptions.</p>
p5404[0, 1]	e.g. p5404[0] = r5488[0] p5404[1] = r5488[1]	<p>CI: Line droop control voltage signal source</p> <p>If the droop is not to be active for the connection point directly at the Active Interface module, then observe the notes provided in the parameter descriptions.</p>
p5405	e.g. 100 %	<p>Line droop control frequency droop no load frequency</p> <p>A suitable value is obtained from the corresponding no load frequencies of the other power generating units in the island grid as well as from the required load distribution.</p>
p5406[0]	e.g. 0 ¹⁾	<p>Line droop control frequency droop supplementary setpoint</p> <p>In island grids with several power generating units, the no-load frequency is dynamically adapted to the instantaneous load and power generating conditions using a higher level island grid control.</p>
p5407	e.g. 4 % ¹⁾	<p>Grid droop control frequency droop gradient</p> <p>A suitable value is obtained from the corresponding gradient values of the other power generating units in the island grid as well as from the required load distribution.</p> <p>In the example, the following procedure provides a practical value to be set: Measure the gradient of the diesel generator characteristic, and set p5407 to the same value.</p>
p5409	e.g. 150 ms	<p>Line droop control frequency droop smoothing time</p> <p>Other power generating units in the island grid must also manifest a frequency droop, however they respond to load changes with a specific "inertia". In order to avoid load peaks in individual power generating units for load steps in an island grid, at least power generating units with similar power ratings must manifest a comparable dynamic response. This dynamic response for active power changes is set using p5409.</p>
p5413	e.g. 50 %	<p>Line droop control additional frequency droop gradient</p> <p>The additional droop offers a fundamental emulation of the dynamic speed dip or overshoots of generators when load steps occur. Easing the output frequency as a result of the additional droop avoids load peaks in the Active Line module, and also helps dampen power oscillations in the island grid.</p>
p5415	e.g. 100 % ¹⁾	<p>Grid droop control voltage droop no load voltage</p> <p>A suitable value is obtained from the corresponding no load voltages of the other power generating units in the island grid as well as from the required load distribution.</p> <p>In the example, the following procedure provides a practical value to be set: Measure the no load voltage of the diesel generator, and in test operation 2, set the output voltage to the same value.</p>

7.4 Commissioning example for an infeed with voltage and frequency control for an island grid.

Parameter	Value	Comment
p5416[0]	e.g. 0 ¹⁾	Line droop control voltage droop supplementary setpoint In island grids with several power generating units, the no-load voltage is dynamically adapted to the instantaneous load and power generating conditions using a higher level island grid control.
p5417	e.g. 4 % ¹⁾	Grid droop control voltage droop gradient A suitable value is obtained from the corresponding gradient values of the other power generating units in the island grid as well as from the required load distribution. In the example, the following procedure provides a practical value to be set: Measure the gradient of the diesel generator characteristic, and set p5417 to the same value.
p5419	e.g. 150 ms	Line droop control voltage droop smoothing time Other power generating units in the island grid must also manifest a voltage droop, however they respond to load changes with a specific "inertia". In order to avoid load peaks in individual power generating units for load steps in an island grid, at least power generating units with similar power ratings must manifest a comparable dynamic response. This dynamic response for reactive power changes is set using p5419.
p5425[0, 1]	e.g. r5488[1, 2]	CI: Line droop control voltage control signal source Selecting the signal source for the voltage control defines at which point the voltage error should be compensated (or at which point, the voltage droop should be active). With the example setting, the terminal voltage of the Active Line Module is corrected/tracked so that at the selected measurement point (here: VSM2 voltage at the circuit breaker) the setpoint voltage is set according to the droop.
p5426	e.g. 50 %	Line droop control voltage control P gain Voltage droop p5415ff supplies the setpoint for the output voltage of the power generating unit. Initially, this voltage is realized at the terminals of the grid inverter. Under load, especially the voltage drops across the inductances (commutating reactor, transformer) result in the corresponding voltage deviations at the connection point (e.g. at the circuit breaker). The voltage control is used to compensate these voltage errors.
p5427	e.g. 500 ms	Line droop control voltage control integration time The voltage control is intended to correct steady-state voltage errors, comparatively slowly. As a consequence, the integration time constant should be selected to be somewhat higher than the smoothing times of the voltage and frequency droop.
5430[1]	e.g. 105 %	Modulation depth controller setting – setting the maximum modulation depth. Limits the modulation depth to avoid harmonics in the output voltage.
p5432[0, 1]	e.g.: p5432[0] = 50 V p5432[1] = -50 V	Modulation depth controller output voltage limiting The pulse-frequency harmonic component of the Active Line Module output voltage depends on the modulation depth (ratio between the AC voltage and DC voltage) and is optimal when r0074 = 94 %. This means that with the modulation depth controller, the setpoint for the DC link voltage can be adapted to the actual AC island grid voltage. When doing this, in the particular application, it must be noted whether, in all operating states, the component is suitable for the V _{dc} control (in this case: inverter on the generator side) for a corresponding change of the DC link voltage (voltage reserve of the generator control, V _{dc_max} limiting, etc.).

7.4 Commissioning example for an infeed with voltage and frequency control for an island grid.

Parameter	Value	Comment
p5436	1)	<p>DC component controller P gain</p> <p>Especially if an island grid contains transformers or line motors, it is absolutely necessary that this control is activated to prevent DC components in the AC current. The controller parameters are preset based on the rated Active Line Module data (assumption: the transformer rating approximately corresponds to the Active Line Module power rating).</p> <p>However, depending on the particular system, adaptations may be required in order to achieve stable operation of the grid droop control. To achieve this, the identification p5480 = 11 of the transformer magnetizing inductance p5492 can be used if data sheet values are not available. In operation, it is possible that the controller gain p5436 must be adapted. To achieve this, evaluate the characteristic of the current DC components r5448[2, 3].</p> <p>Note Parameter p5436 is not effective while the transformer is being magnetized. To avoid saturation effects in the transformer during magnetization (especially for high modulation depth r0074), we recommend that the DC component control is activated using p3650.</p>
p5451	e.g. 1	<p>BI: Current hysteresis controller operating mode</p> <p>This parameter is used to define as to whether the Active Line Module in the island grid is presently the most powerful generating unit (= 0) – or not (= 1). In this case, the rated power of the power generating unit is not decisive, but the short-circuit power (for example, a nominally smaller diesel generator can supply higher short-circuit currents). The operating mode information is used in the Active Line Module to facilitate fast and stable resynchronization after a grid short-circuit with the support from possibly other power generating units.</p>
p5478[0, 1]	<p>e.g.:</p> <p>chassis format devices: p5478[0] = 90 % p5478[1] = 123 %</p> <p>booksize format devices: p5478[0] = 90 % p5478[1] = 90 %</p>	<p>Grid droop control current limits</p> <p>The current limits for current controlled operation (e.g. p3530ff) are not effective in grid droop operation, but only the apparent current limiting according to p5478. In so doing, a distinction is made between normal operation (island grid voltage > p5459[2]) and grid short-circuit. For example, a lower current limit in normal operation makes sense so that larger motors in an island grid can be started (heavy-duty starting). When the current limit is reached, the output voltage decreases so much that the current limit is permanently maintained (and the motor continues to accelerate with reduced voltage). The current limit [0] is also applicable for short-circuit situations (i.e. grid voltage < p5459[2], if a power source with a higher rating for the short-second current is available in the island grid (p5451 = 1). The resulting current limits in amps are indicated in r5479.</p>
Grid transformer		
p5480	e.g. 1 (normal operation)	<p>Transformer magnetization mode</p> <p>Activating the transformer magnetization</p> <p>Notice: When magnetization is deactivated, with the DC link precharged, the circuit breaker is controlled independent of the operating state of a transformer that may be available. This can result in overloading grid or plant components or even damage if a transformer is present. We recommend that an external, independent synchronizing monitoring function is used. Also see the following chapter about transformer magnetization.</p>
p5481[0]	e.g. 2 s	<p>Transformer magnetization times: Voltage ramp-up time</p> <p>Ramp-up time to magnetize the transformer</p>

7.4 Commissioning example for an infeed with voltage and frequency control for an island grid.

Parameter	Value	Comment
p5481[1]	e.g. 0.7 s ¹⁾	Transformer magnetization times: Circuit breaker bounce time If the time set is less than the actual bounce time, extremely high currents can occur when the pulses are enabled, which can damage the circuit breaker. Note: A permanent feedback signal from the switch is not a sure sign that the switching process has been completed! Note: If problems occur when connecting to the grid (e.g. overcurrent, overvoltage, power failure F6200), then you should increase the bounce time.
p5483	e.g. 1	BI: Grid circuit breaker enable (Sets the signal source for closing the circuit breaker after voltage ramp-up) Enables the function for closing the circuit breaker when transformer magnetization and synchronization are selected. For instance, this enable can be used to keep the power generating system in a hot standby mode – synchronized with the grid – so that it can immediately go into grid operation with a rising edge.
p5486[0]	e.g. 400 V	Rated transformer voltage, primary, infeed transformer Enter the island grid rated voltage (in the application example: Rated voltage at the terminals of switch 7). Internally, the transformer ratio is calculated from the ratio between p0210 and p5486[0].
p5487[0]	e.g. INFEED.r5461[0]	Transformer primary voltage signal source, conductor voltage u12 Signal input for the measured conductor-conductor voltage u12 at the circuit breaker (7) to convert over to the transformer secondary at the Active Line Module. The converted voltage value transformed into space vector coordinates is indicated in r5488[0, 1].
p5487[1]	e.g. INFEED.r5462[0]	Transformer primary voltage signal source, conductor voltage u23 Signal input for the measured conductor-conductor voltage u23 at the circuit breaker (7) to convert over to the transformer secondary at the Active Line Module. The converted voltage value transformed into space vector coordinates is indicated in r5488[0, 1].
p5490	¹⁾	Transformer leakage inductance Use the data from the transformer data sheet – or measure using the transformer ID p5480 = 13)
p5492	¹⁾	Transformer magnetizing inductance Use the data from the transformer data sheet – or measure using the transformer ID p5480 = 11). Carefully observe the notes regarding r5491 in the List Manual!
r5493	-	CO/BO: Grid circuit breaker control signals Bit 0: Connected with a digital output to control an external DC link precharging system. For instance, an external DC link precharging system is required if transformer magnetization is required before connecting to an existing grid, however, at this point in time, a DC link voltage cannot be established by the power source/generator. When dimensioning the external precharging system, it should be noted that this must cover the losses in the line filter and in the transformer itself during magnetization (see function diagram FP7990).

7.4 Commissioning example for an infeed with voltage and frequency control for an island grid.

Parameter	Value	Comment
p5494[0]	e.g. 93 %	<p>Magnetizing scale values</p> <p>The adjustable parameter defines the percentage of the rated voltage for transformer magnetization. In practice, the ideal value of 100 % is generally not required. This is because a small step-like residual magnetization when closing the circuit breaker does not result in any inadmissible settling currents.</p> <p>Especially in the case of an external DC link pre-charging system via a separate DC circuit may mean that reduced magnetization is required, if the achievable magnitude of the DC link voltage is not sufficient to provide 100 % transformer magnetization. It should be ensured that during magnetization, the Active Line Module modulation depth does not reach the overmodulation range ($r0074 > 100 \%$), in order to avoid harmonic currents and DC current components.</p>
p6420[0]	1)	<p>Grid transformer phase shift, infeed transformer</p> <p>Enter the phase shift of the grid transformer. Vector group Dy5 => -150° (is determined more precisely with transformer identification p5480 = 12).</p> <p>For the successful transformer identification in mode p5480 = 12, the coarse setting must be made manually (also see the following chapter on transformer commissioning).</p> <p>Note: With the circuit breaker closed at the infeed transformer, a correct setting of p6420[0] and p6421[0] can be identified by the fact that the characteristics with respect to time of voltages r3468[0, 1] and r5488[0, 1] approximately coincide for low load conditions.</p>
p6421[0]	1)	<p>Grid transformer gain adaptation, infeed transformer</p> <p>(Is determined more precisely with transformer identification p5480 = 12).</p> <p>For successful transformer identification in mode p5480 = 12, the coarse setting must be made manually (also see the following chapter on transformer commissioning).</p>
Additional parameter settings for a black start		
p5580	e.g. 2	<p>Island grid black start mode</p> <p>A black start designates establishing a voltage in a grid that initially was in a no voltage condition. It must be ensured that the supply for the power generating system itself must be ensured on the plant side before the black start.</p> <p>For a black start (p5580 = 2) initially, a check is made as to whether the island grid is in a no-voltage condition, before the circuit breaker between the infeed and the island grid is closed. The infeed voltage is then increased until the rated voltage is reached in the island grid. An automatic black start can be set using p5580 = 3.</p> <p>If the island grid is already at a certain voltage level, then an immediate switch is made into grid droop operation (standard switching to an existing grid). Otherwise, a black start is realized.</p>
p5581[0]	e.g. 2 s	<p>Island grid times, black start voltage ramp duration</p> <p>Sets the ramp duration for the grid voltage.</p>

7.4 Commissioning example for an infeed with voltage and frequency control for an island grid.

Parameter	Value	Comment
p5581[1]	e.g. 1 s	Island grid times, black start circuit breaker bounce time Sets the bounce time for the circuit breaker on the grid side of the grid transformer. An interruption-free connection between the grid and transformer is only ensured after the bounce time has elapsed.
p5586[0]	e.g. 3 % ¹⁾	Island grid scaling values, black start voltage limit A black start is not carried out if the voltage in the island grid is greater than $p5586[0] * p0210$. For example, this can be the case if capacitors in the grid only discharge slowly.

¹⁾ Values are system-specific and must be taken into special consideration when adapting to the particular system configuration.

Parameter settings for the drive device "MOTORINVERTER"

In the project, right click on "MOTORINVERTER" under "Drives" and then select "Expert list".

The subsequent list to parameterize the inverter on the generator side includes special settings for grid droop operation of the power generating system. We would like to refer to the relevant manuals with regard to commissioning the generator control itself.

Note

The DC link voltage control is, for the drive device "MOTORINVERTER", part of the "Technology controller" function module. The function module can be activated during commissioning.

Note

Activation of the function modules by a higher-level control system

The function modules can also be activated by a higher-level control system. For this purpose, parameter p0009 of the Control Unit must be set to "2" (defining the drive type function module). You can then use parameter p0108[x].y = 1 of the Control Unit to activate the individual function modules.

In this case, the object number of the MOTORINVERTER must be used for the index "x".

The meaning of the "y" bit for the technology control function module is as follows:

- Bit 16 = technology controller

The function modules are activated with p0009 = 0.

7.4 Commissioning example for an infeed with voltage and frequency control for an island grid.

Table 7- 5 Parameter settings for the drive device "MOTORINVERTER"

Parameter	Value	Comment
p1200[0]	e.g. 1	Flying restart operating mode in DDS 0 Flying restart always active, start in setpoint direction "Flying restart always active" is especially required for applications without encoder.
p1300[0]	e.g. 20	Open-loop/closed-loop control operating mode in DDS 0 Speed control (encoderless)
p1501[0]	e.g. 1	BI: Change over between closed-loop speed/torque control in CDS 0 1 signal = Closed-loop torque control 0 signal = Closed-loop speed control
Technology controller		
p3422	¹⁾	Total DC link capacitance Note: set the same value as for INFEED.p3422 (after the DC link identification routine!)
p3510	e.g. 1035 V for 690 V AC devices	DC link voltage setpoint Standard setting: same value as for INFEED.p3510. If required, adapt so that the modulation depth controller (INFEED.r5433) can operate within its limits.
p3511	e.g. INFEED.r5433	CI: DC link voltage supplementary setpoint Interconnect with the value "Modulation depth control output" of the infeed. This BICO interconnection ensures that in grid droop operation of the Active Line Module, the DC link voltage is adapted to the actual grid voltage; in turn, this means minimum harmonic content of the grid voltage.
p3513	e.g. INFEED.r5402.0	BI: Inhibit voltage-controlled operation Interconnect to "Grid droop control inactive" signal from the infeed. This BICO interconnection ensures that the motor inverter controls the DC link voltage if the Active Line Module is in grid droop operation.
p3520[0]	e.g. INFEED.r0082	CI: DC link precontrol power Interconnect to "Active power actual value" of the infeed.
p3521[0]	e.g. 80 %	DC link pre-control power scaling It makes sense to precontrol the power demand in the DC link voltage controller, especially when correcting grid-side load steps in grid droop operation. We recommend a scaling of approx. 80 % to 100 %.
p3523[0]	e.g. 8 ms	DC link pre-control power smoothing It makes sense to precontrol the power demand in the DC link voltage controller, especially when correcting grid-side load steps in grid droop operation. To suppress high-frequency disturbing components, we recommend that the pre-control signal is smoothed between 1 ms and 10 ms.
p3560	e.g. 70 %	Vdc controller proportional gain If a very high dynamic performance of the Vdc control is not required, then we recommend a setting value of < 100 % to increase the ruggedness (stability) of the controller.

¹⁾ Values are system-specific and must be taken into special consideration when adapting to the particular system configuration.

7.4.7 Signal interfaces

Description

The following signals are required by the drive unit for operation and/or provided for monitoring purposes.

Signals transferred to the drive unit

This involves a list of typical signals for communication with the higher-level control system.

Table 7- 6 Signals transferred to the drive unit

Parameter	Drive Object	Signal	Type	Unit
p0840[0]	INFEED	BI: ON/OFF1 Sets the signal source for control word 1 bit 0 (ON/OFF1).	Bit	-
p5401	INFEED	BI: Grid control activation 1 signal: Activation of grid droop control and deactivation of closed-loop DC-link voltage control/closed-loop current control. 0 signal: Activation of grid droop control and deactivation of closed-loop DC-link voltage control/closed-loop current control.	Bit	-
p3611	INFEED	CI: Infeed reactive current supplementary setpoint Reactive current setpoint for operation with p5401 = 0	Unsigned32 / FloatingPoint32	-
p5406[0...1]	INFEED	CI: Grid droop control frequency droop supplementary setpoint dynamic supplementary frequency setpoint for operation with p5401 = 1	Unsigned32 / FloatingPoint32	-
p5416[0...1]	INFEED	CI: Grid droop control voltage droop supplementary setpoint dynamic supplementary voltage setpoint for operation with p5401 = 1	Unsigned32 / FloatingPoint32	-
p5451	INFEED	BI: Current hysteresis controller operating mode Parallel operation with diesel generator 1 signal: Combined operation (INFEED and additional infeeds together supply the island grid, INFEED is not the power generating unit with the highest short-circuit power) 0 signal: Operation by itself (INFEED exclusively supplies the island grid and/or is the power generating unit with the highest short-circuit power)	Bit	-

7.4 Commissioning example for an infeed with voltage and frequency control for an island grid.

Parameter	Drive Object	Signal	Type	Unit
p5480	INFEED	Transformer magnetization mode 0 = deactivated 1 = normal operation Notice: When magnetization is deactivated, with the DC link precharged, the circuit breaker is controlled independent of the operating state of a transformer that may be available. This can result in overloading grid or plant components or even damage if a transformer is present. We recommend that an external, independent synchronizing monitoring function is used.	Integer, 16-bit	-
p5483	INFEED	BI: Grid circuit breaker enable (Sets the signal source for closing the circuit breaker after voltage ramp-up) Enables the function for closing the circuit breaker when transformer magnetization and synchronization are selected. For instance, this enable can be used to keep the power generating system in a hot standby mode – synchronized with the grid – so that it can immediately go into grid operation with a rising edge.	Unsigned32 / Binary	-
p5580	INFEED	Sets the mode for the black start. Using this function, an island grid can be established, which is initially in a no-voltage state. The Active Line Module acts as grid voltage source or as grid former for the connected island grid.	Integer, 16-bit	-

Signals transferred from the drive unit

This involves a list of typical signals for communication with the higher-level control system.

Table 7-7 Signals transferred from the drive unit

Parameter	Drive Object	Signal	Type	Unit
r0899.0	INFEED	Ready for switching on 1 signal: Ready for switching on 0 signal: Not ready for switching on	Bit	-
r0899.1	INFEED	Ready 1 signal: Ready 0 signal: Not ready	Bit	-
r0899.2	INFEED	Operation enabled 1 signal: Operation enabled 0 signal: Operation not enabled	Bit	-
r0046.0	INFEED	OFF1 enable missing 1 signal: OFF1 enable missing 0 signal: OFF1 enable not missing	Bit	-

7.4 Commissioning example for an infeed with voltage and frequency control for an island grid.

Parameter	Drive Object	Signal	Type	Unit
r2139.3	INFEED	Fault active 1 signal: Fault active 0 signal: Fault not active The 1 signal is set if a fault occurs in one or more drive objects	Bit	-
r2139.7	INFEED	Alarm active 1 signal: Alarm active 0 signal: Alarm not active The 1 signal is set if an alarm occurs in one or more drive objects	Bit	-
r5402	INFEED	Line droop control status word	Unsigned16	-
r5411[1]	INFEED	Grid control frequency droop active power (smoothed) Displays the input active power of the active power frequency droop.	FloatingPoint32	kW
r5421[1]	INFEED	Grid control frequency droop reactive current (smoothed) Displays the input reactive current of the reactive current voltage droop.	FloatingPoint32	A
r0068	INFEED	Absolute current actual value Displays actual absolute current.	FloatingPoint32	Arms
r5410	INFEED	Grid control frequency droop output Displays the smoothed output frequency of the active power frequency droop.	FloatingPoint32	Hz
r0025	MOTORINVERTER	Output voltage smoothed Displays the smoothed output voltage of the power unit.	FloatingPoint32	Vrms
r0027	MOTORINVERTER	Absolute actual current smoothed Displays the smoothed absolute actual current value.	FloatingPoint32	Arms
r0024	MOTORINVERTER	Output frequency smoothed Displays the smoothed converter frequency.	FloatingPoint32	Hz
r0070	MOTORINVERTER	Actual DC link voltage Displays the measured actual value of the DC link voltage.	FloatingPoint32	V
r0722.0	CU	CU digital inputs, status: DI 0 (X122.1) Feedback signal, circuit breaker (prerequisite is the wiring of the feedback signal with the DI0 of the Control Unit, terminal X122.1)	Bit	-
r5482	INFEED	Displays the status of the sequence control for transformer magnetization, black start and island grid synchronization	Integer, 16-bit	-

7.5 Commissioning example of an infeed with dynamic grid support for a power grid

7.5.1 Design

Photovoltaic plant

The example shows a photovoltaic plant feeding the electrical energy generated into a power grid.

Closed-loop control

Characteristic for a photovoltaic system is that the energy flows in one direction from the DC link into the power grid. The optimum operating voltage for the solar cells or the DC link voltage is highly dependent on the working point, and is decisive for achieving the best possible efficiency. The setpoint voltage for the maximum power (maximum power point: MPP) of course depends on the actual intensity of solar radiation but also on many other parameters, such as the ambient temperature.

A superimposed maximum power-point closed-loop control (MPP) in an external controller determines the optimum V_{DC} setpoint and transfers this to the closed-loop controller of the Active Line Module.

The Active Line Module is operated in "closed-loop DC link voltage control" mode in this case.

Design

The solar cells are interconnected in such a manner that they directly charge the DC link of the Active Line Modules.

Sequence

The higher-level control system closes the optional DC contactors and issues the command to start the line infeed, provided that sufficient sunlight is present. The DC link voltage generated from the PV field must correspond to at least 1.5 times the transformer secondary voltage. First, the grid transformer is magnetized and synchronized with the network. The required power must be provided from the PV field. The VSM10 performs sensing of the line voltage on the primary side of the grid transformer until synchronization is achieved. After synchronization, the circuit breaker is closed and power infeed to the network started.

Line fault

Fault ride through in accordance with grid codes, occurs automatically via the grid inverter according to the required parameter settings.

Block diagram

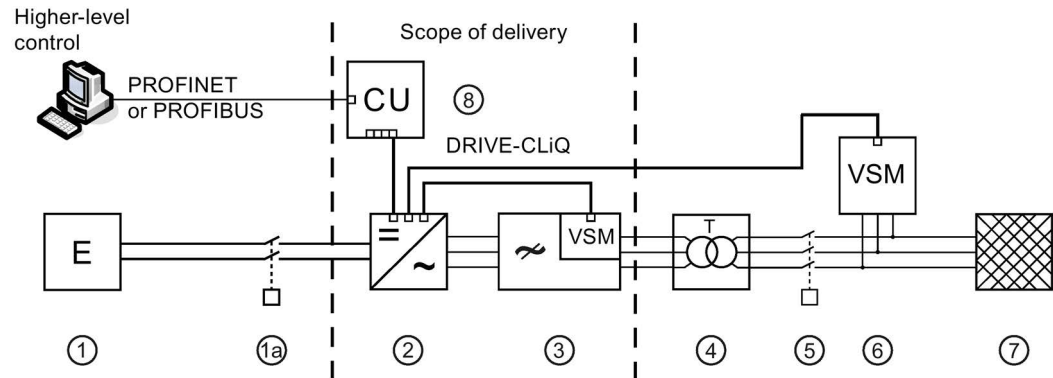

Figure 7-3 Infeed to a power grid

Table 7- 8 Components for infeed to a power grid

Number	Description
1	Photovoltaic plant
1a	Optional DC contactor
2	Active Line Module
3	Active Interface Module with integrated Voltage Sensing Module VSM10
4	Grid transformer
5	Circuit breaker
6	VSM10 Voltage Sensing Module for measuring the line voltage on the primary side of the grid transformer
7	Power grid
8	Control Unit

7.5.2 General information

Commissioning procedure

The following procedure is used to commission (offline) an infeed with dynamic grid support for a power grid.

A photovoltaic system for power generation is used as an example in this case.

1. Create project.
2. Create drive units.
The drive unit for feeding into the grid is called INFEED.
3. Function modules for line infeed to a power grid.
4. Create additional VSM10 for measuring the line voltage on the primary side of the grid transformer.
5. Adapt the topology and the VSM10 assignments.
6. Perform additional parameter settings in the expert list.

To do this, the sequence of the individual sequential steps for identification and setting of the transformer data must be taken into consideration (see Commissioning grid-friendly transformer magnetization (Page 102)).

For weak networks (large inductance and low short-circuit power), additional recommended settings apply (see Notes for commissioning systems for operation on grids with low short-circuit power (fault level) and variable grid parameters (Page 138)).

Note

Description of the commissioning process

The basic steps when commissioning a SINAMICS S120 are contained in the Commissioning Manual.

Note

Access level

Some of the parameters to be set are accessible only under access level 4 (Service). This access level is protected by password. Only authorized persons will receive the required password within the scope of expert training provided by Siemens.

7.5.3 Function modules for creating a line infeed in a power grid

In the project, click on "INFEED" under "Infeeds" and then select "Properties...".

- Under the "Function modules" tab, select the "Grid transformer" and "Dynamic grid support" modules, and when required, select additional modules.

Note

Activation of the function modules by a higher-level control system

The function modules can also be activated by a higher-level control system. For this purpose, parameter p0009 of the Control Unit must be set to "2" (defining the drive type function module). You can then use parameter p0108[x].y = 1 of the Control Unit to activate the individual function modules.

In this case, the object number of the INFEED must be used for the index "x".

The meanings of the "y" bits for the function modules for grid infeed are as follows:

- (Bit 04 = supplementary controls)
- Bit 04 = grid transformer
- Bit 07 = dynamic grid support
- (Bit 12 = grid droop control)

The function modules are activated with p0009 = 0.

7.5.4 Creating an additional VSM10

If the drive device was commissioned with full DRIVE-CLiQ topology using an automatic configuration, then the VSM10 modules are already in the topology. In this case, the number should not be changed, but the assignment checked corresponding to the following chapter, and if required adapted.

Procedure if the project was configured offline

In the project, double-click on "INFEED" under "Infeeds" and click on "Wizard..." in the configuration window.

- Do not change anything in the first screen.
- Select "Number of VSMs:" in the second screen in the list box Select "2".
A VSM is entered in the "Number VSM" for each Active Line Module; this number of VSMs must be incremented by 1 to create an additional VSM10.
- Click through the remaining screens without making changes and close the wizard.
- This adds an additional VSM10 to the topology.

7.5.5 Adapting the topology and the VSM10 assignments

Double-click on "Topology" in the project; the topology view appears.

The topology looks like this after the above commissioning steps, for instance:

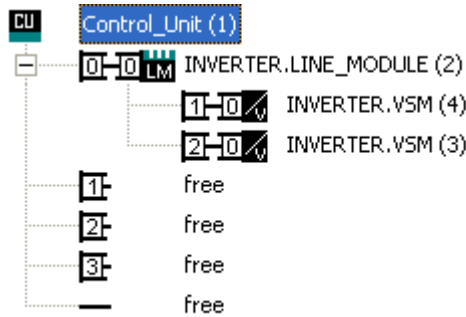

Figure 7-4 Topology

The numbers in brackets to the right of the components in the topology view are the "Component numbers".

- The VSM10 for the closed-loop control functionality of the infeed must be connected to the -X402 DRIVE-CLiQ socket (booksize format: -X202) of the INVERTER infeed.
- The VSM10 for synchronization with the power supply (on the primary side of the grid transformer) must be connected to the -X401 DRIVE-CLiQ socket (booksize format: -X201) of the INFEED drive.

You must use the expert list to check the assignments of the VSM10 components present in the project and correct these where necessary.

The following settings refer to the topology shown above.

- The VSM10 with component number 3 is responsible for the closed-loop control functionality of the infeed.
 INFEED.p0140 = 1 (access level 4)
 INFEED.p0141[0] = 3 (access level 4)
- The VSM10 with component number 4 is responsible for synchronizing the infeed with a power grid (VSM2 functionality).
 INFEED.p0150 = 1 (access level 4)
 INFEED.p0151[0] = 4 (access level 4)

7.5.6 Performing additional parameter settings in the expert list

The following table provides an overview of the most important adjustable parameters with typical values and notes for a power grid application.

This overview should provide help when commissioning the system. It does not replace the information in the previous chapters or the parameter descriptions and function charts in the List Manual.

Depending on the application, in individual cases, it may be necessary to change parameters, which are not listed in the tables.

Parameter settings for "INFEED" drive unit

In the project, right click on "INFEED" under "Infeeds" and then select "Expert list".

Table 7- 9 Parameter settings for "INFEED" drive unit

Parameter	Value	Comment
p0210	¹⁾	Enter the supply voltage for the grid converter (corresponds to the rated value of the voltage at the transformer secondary or at the AIM connecting terminals)
p0840[0]	e.g. INFEED.r2090.0	BI: On/Off1 via PROFIdrive PZD1, bit 0 On command for the Active Line Module
p0844[0]	e.g. CONTROL_UNIT.r0722.0	BI: 1.OFF2 in CDS 0 via DI0 (-X122.1) of the Control Unit Signal sink for the OFF2 command of the Active Line Module
p0852[0]	e.g. 1	BI: Enable operation Enable for transformer magnetization and controlled grid infeed operation
p0860	e.g. CONTROL_UNIT.r0722.1	BI: Grid contactor, feedback signal The feedback signal contact of the circuit breaker must be connected in order that the transformer magnetization function operates correctly. For this example, a connection is made to terminal DI1 (-X122.2) of the Control Unit.
p0861	e.g. 200 ms ¹⁾	Grid contactor monitoring time Monitors activation/feedback signal from the circuit breaker. The value to be set depends on the switching times of the switch being used.
Pulse frequency wobulation		
p1810.2	e.g. no	Activate pulse frequency wobulation (access level 4) Wobulating (sweeping) the pulse of frequency ensures that the pulse-frequency voltage and current components are distributed over a frequency range. This makes sense if the distortion power at the individual frequencies should be reduced between 2 kHz and 9 kHz. Pulse frequency wobulation (sweeping) in current controlled operation results in additional harmonics in the current measured values. This is the reason that the function should only be activated if this is necessary with the line filter used in order to maintain pulse-frequency interference limit values. Wobulation is generally not required when using an Active Interface Module!
p1810.4	e.g. no	Inhibit wobulation (sweep) amplitude (access level 4) If pulse frequency wobulation is always activated with p1810.2, using p1810.4 the wobulation amplitude p1811 can be enabled for normal operation of the Active Line Module.
p5526[0].4 p5526[1].4	e.g. no	Inhibit wobulation (sweep) amplitude (access level 4) If pulse frequency wobulation is always activated with p1810.2, using p5526.4 the wobulation amplitude p1811 can be enabled for operation with dynamic grid support (p5501 = 1).
p1811	e.g. 0 % ¹⁾	Pulse frequency wobulation amplitude (access level 4) If wobulation is activated and enabled, the wobulation amplitude can be selected using this adjustable parameter. The higher the setting value, the wider the pulse frequency spectrum of the output voltage; however, the harmonics in the current measured values are also higher. Generally, setting values of about 5 % are sufficient.

7.5 Commissioning example of an infeed with dynamic grid support for a power grid

Parameter	Value	Comment
DC link control		
p3410	0	Infeed identification method – identification (ID) off
p3415[0]	10,00 % ¹⁾	Infeed excitation current L identification – run 1 Amplitude of the measured currents for identifying the DC link capacitance For grids with low fault level (short-circuit rating), we recommend reducing the measuring current to 10 % (possibly down to 7 %) in order to ensure stable grid operation during the identification routine. Identification is not possible for extremely low grid fault levels.
p3415[1]	10,00 % ¹⁾	Infeed excitation current L identification – run 2 Amplitude of the measured currents for identifying the DC link capacitance For grids with low fault level (short-circuit rating), we recommend reducing the measuring current to 10 % (possibly down to 7 %) in order to ensure stable grid operation during the identification routine. Identification is not possible for extremely low grid fault levels.
p3510	e.g. p0210 * 1.5	Infeed DC link voltage setpoint for 400 V 3 AC devices: 600 V DC Normally, the setpoint should not be selected to be lower than 1.5x the grid voltage, as the control range for the current control would otherwise be limited too much, and current harmonics would occur. Upwards, the setpoint is limited by the maximum boost (step-up) factor p3508.
p3511	¹⁾	CI: Infeed DC link voltage supplementary setpoint Using the connector for the supplementary setpoint, the DC link voltage setpoint can be changed; for example, this is required for photovoltaic applications for the higher-level MPP control.
Grid transformer		
p5460	¹⁾	VSM2 input grid voltage voltage divider Sets a voltage divider for the Voltage Sensing Module 2 (VSM2). Using a measuring transformer, the 100 V input of the VSM can also be used to measure voltages in a medium voltage grid. For a 20 kV primary voltage and connection at -X521 (100 V input) and a measuring transformer with a step-down factor of 200:1, a value of 20000 % can be set, for example.
p5480	e.g. 1 (normal operation)	Transformer magnetization mode Also see the following chapter about transformer magnetization.
p5481[0]	e.g. 2 s	Transformer magnetization ramp-up time/bounce time/timeout: Voltage ramp-up time Ramp-up time to magnetize the grid transformer
p5481[1]	e.g. 1 s ¹⁾	Transformer magnetization ramp-up time/bounce time/timeout: Circuit breaker bounce time If the time set is less than the actual bounce time, extremely high currents can occur on pulse enable and cause damage to the circuit breaker. Note: A permanent feedback signal from the switch is not a sure sign that the switching process has been completed! Note: If problems occur when connecting to the grid (e.g. overcurrent, overvoltage, power failure F6200), then you should increase the bounce time.
p5483	e.g. 1	BI: Transformer magnetizing signal source for circuit breaker activation (sets the signal source for activating the circuit breaker after voltage ramp-up) Enables the function for closing the circuit breaker when transformer magnetization and synchronization are selected

7.5 Commissioning example of an infeed with dynamic grid support for a power grid

Parameter	Value	Comment
p5486[0]	e.g. 10000 V	Transformer rated voltage on the primary side, infeed transformer Enter the rated voltage at the connection point on the power grid side of the infeed transformer. Internally, the transformer ratio is calculated from the ratio between p0210 and p5486[0].
p5487[0]	e.g. INFEED.r5461[0]	Transformer primary voltage signal source, conductor voltage u12 Signal input for the measured conductor-conductor voltage u12 at the circuit breaker (5) to convert over to the transformer secondary at the Active Line Module. The converted voltage value transformed into space vector coordinates is indicated in r5488[0, 1].
p5487[1]	e.g. INFEED.r5462[0]	Transformer primary voltage signal source, conductor voltage u23 Signal input for the measured conductor-conductor voltage u23 at the circuit breaker (5) to convert over to the transformer secondary at the Active Line Module. The converted voltage value transformed into space vector coordinates is indicated in r5488[0, 1].
p5490		Transformer leakage inductance Use the data from the transformer data sheet – or measure using the transformer ID (p5480 = 13) See also: Chapter on commissioning the grid transformer
p5492		Transformer magnetizing inductance Use the data from the transformer data sheet – or measure using the transformer ID p5480 = 11) Observe the notes about r5491 in the List Manual!
p6420[0]	¹⁾	Grid transformer phase shift, infeed transformer Enter the phase shift of the grid transformer. Vector group Dy5 => -150° (is determined more precisely with transformer identification p5480 = 12). For the successful transformer identification in mode p5480 = 12, the coarse setting must be made manually (also see the following chapter on transformer commissioning!)
p6421[0]	¹⁾	Grid transformer gain adaptation, infeed transformer (Is determined more precisely with transformer identification p5480 = 12). For successful transformer identification in mode p5480 = 12, the coarse setting must be made manually (also see the following chapter on transformer commissioning!)
Dynamic grid support		
p5500	e.g. 88(hex)	Dynamic grid support configuration. The setting defines how the Active Line Module responds when riding through grid voltage dips (down to 0% residual voltage). Generally, grid codes for feeding power into power grids as well as for non-symmetrical grid faults specify a defined support current and a sinusoidal current waveform. In this case p5500.3 = 1 must be set. The current control when fast voltage changes occur is improved by using dynamic current limits: p5500.7 = 1. The additional setting bits (modes regarding the type of reactive and active power support and for calculating the reactive support current) can be taken from the List Manual.

7.5 Commissioning example of an infeed with dynamic grid support for a power grid

Parameter	Value	Comment
p5501	e.g. 1	<p>BI: Dynamic grid support activation Signal to activate the dynamic grid support.</p> <p>A difference to normal operation of the Active Line Module when using p5501 = 1 only becomes effective if the grid voltage lies outside the selected tolerance band p5505[0, 2]: In this particular case (r5502.1 = 1) an additional reactive power is injected into the grid, whose magnitude with p5506 depends on the grid voltage error. Steady-state reactive current setpoints, which apply independent of instantaneous grid voltage fluctuations, must still be entered using p3610/p3611.</p> <p>When support is activated (i.e. p5501 = 1) the internal current control is extended, so that grid faults are ridden through with a defined grid current; the Active Line Module is only shutdown (fault tripped) to protect the power unit and the Active Interface module itself (overload, overvoltage/undervoltage in the DC link). For remaining voltage and frequency deviations, to protect the grid, the grid monitoring must be set according to local requirements and regulations.</p>
p5504	e.g.: p5504[0] = r5488[0] p5504[1] = r5488[1]	<p>CI: Dynamic grid support voltage signal source</p> <p>Interconnection with r5488 is especially required, if a transformer is used and the connection point of the power generating unit is not located at the connection side of the Active Line Module, but instead is on the medium voltage side, for example.</p>
p5505[0..3]	In accordance with country-specific guideline ¹⁾	Dynamic grid support characteristic voltage values
p5506[0..3]	In accordance with country-specific guideline ¹⁾	Dynamic grid support characteristic reactive current setpoint
p5507[0]	e.g. 20 ms ¹⁾	<p>Dynamic grid support times, minimum time dynamic grid support</p> <p>The adjustable parameter defines the time that the grid voltage must again lie within tolerance limits before support with a dynamic reactive current is exited. Depending on the particular grid code, here, significantly lower values must be selected than the default setting (e.g. for China).</p>
p5507[3]	e.g. 8 ms ¹⁾	<p>Dynamic grid support times, smoothing time instantaneous value</p> <p>The adjustable parameter defines the fast smoothing time for breaking down the voltage into a positive and negative sequence system. Especially for grids with high inductance, the smoothing should be greater than the default setting in order to avoid resonance problems.</p>
p5508[0]	e.g. -30 V ¹⁾	<p>Dynamic grid support Vdc threshold, offset overvoltage</p> <p>A sudden load change at the beginning of a grid short-circuit increases the risk of a fault trip due to Vdc overvoltage. Using this adjustable parameter, a threshold for the DC link voltage is defined (Vdc_max – p5508[0]). When this is exceeded, then the Active Line Module control responds with an increased active power output. For photovoltaic applications, for example, the threshold must be selected to be higher than the no-load voltage of the photovoltaic array.</p>
p5509[0]	e.g. 20 %	<p>Dynamic grid support scaling values, ramp reactive current at the start/end of grid support</p> <p>If, in the grid code for dynamic support current, rise times of > 30 ms are specified, then generally, ramp gradients of p5509[0] = 10 % .. 20 % are sufficient, and avoid control variables from overshooting.</p>
p5509[1]	e.g. 0.1 %	<p>Dynamic grid support scaling values, reactive current ramp when the Vdc threshold is exceeded</p> <p>For the setting p5509[1] = 0.1 %, the support current is not reduced when reaching the Vdc threshold p5508. This is specified in many grid codes.</p>

7.5 Commissioning example of an infeed with dynamic grid support for a power grid

Parameter	Value	Comment
p5509[5]	e.g. 85 %	Dynamic grid support scaling values, current limiting scaling Important note: This limit for the Active Line Module apparent current becomes effective when dynamic grid support is activated (p5501 = 1) – and is therefore also active if the grid voltage lies within the permissible tolerance. For power generation operation, if the full overload capability according to the datasheet (i.e. maximum current r0209) is not demanded from the Active Line Module, then this apparent current limit should be reduced, in order to improve settling operations when grid dips occur.
p5509[6]	e.g. 5 %	Dynamic grid support scaling values, grid voltage change for fast negative sequence system calculation The adjustable parameter defines a voltage threshold to quickly adapt breaking down the voltage into a positive and negative sequence system. Especially for grids with low short-circuit power, the threshold should be selected higher than the default setting (3 % .. 5 %), in order to avoid resonance problems.
p5509[7]	e.g. 100 %	Dynamic grid support scaling values, grid dissymmetry current limit positive sequence system If, also for non-symmetrical grid voltage dips, a support current is specified (corresponding to the relevant grid code), then the current limit p5509[7] must be appropriately increased for the positive sequence system.
p5509[8]	e.g. 0.1 %	Dynamic grid support scaling values, grid dissymmetry current limit negative sequence system The majority of grid codes also specify a symmetrical support current for unsymmetrical grid dips (pure positive sequence system support: p5509[8] = 0.1 %). If dynamic support is required for the negative sequence system, then the current limit can be appropriately increased up to 100%.
p5509[9]	e.g. 20 %	Dynamic grid support scaling values, grid dissymmetry minimum value for the start of grid support For non-symmetrical grid voltage dips, in some instances other specifications apply, and therefore other settings than for the symmetrical situation. As a consequence, a threshold value is required in order to identify the start of unsymmetry. For soft grid conditions, the value should be increased when compared to the default settings (in this case, 20 %).
p5509[10]	e.g. 10 %	Dynamic grid support scaling values, grid dissymmetry minimum value for the end of grid support For non-symmetrical grid voltage dips, in some instances other specifications apply, and therefore other settings than for the symmetrical situation. As a consequence, a threshold value is required in order to identify the end of unsymmetry. For soft grid conditions, the value should be increased when compared to the default settings (in this case, 10 %).
p5509[11]	e.g. 25 %	Dynamic grid support scaling values, active current limiting scaling This active current limiting becomes effective as soon as the grid voltage lies outside the tolerance (r5502.1 = 1) and a dynamic support current is impressed. The setting must be made dependent on the particular grid code. Contrary to this, the active current limiting in the Q mode and the Z mode (see parameter description p5500) only becomes effective if the grid voltage is less than p5529[2] and as a consequence, a grid short-circuit is identified (r5502.4 = 1).

1) Values are system-specific and must be taken into special consideration when adapting to the particular system configuration.

7.5.7 Additional parameter settings for grid monitoring

The grid monitoring comprises three components, which can be set using configuration parameter p5540:

1. Monitoring of the grid voltage and frequency (activated using p5540.0). Initiation of fault message F6851 when limits p5543 and p5544 are exceeded.

In addition, the voltage and frequency check can be activated when switching on using p5540.9. To do this, before the operating enable, a check is made against limits p5543[2, 3] and p5544[2, 3] and the system waits until these limits are complied with.

2. Actively influencing the grid frequency in the case of an actual island learned grid situation, in order to reach monitoring limits (Point 1) (activated using p5540 bit 1).
3. Voltage-time monitoring and frequency-time monitoring (activated using p5540.4 and p5540.7). The monitoring thresholds p5543 and p5544 are deactivated when voltage-time monitoring or frequency-time monitoring are active.

The monitoring is activated via signal input p5541, the state is indicated in r5542.

The permissible limits for voltage and frequency must be set corresponding to the specific country grid codes (p5543, p5544).

For simultaneous operation of dynamic grid support with reactive current and island grid detection, the delay time for island grid detection p5545[0] must be selected just as long as the permissible duration of a complete voltage dip.

Parameter settings for grid monitoring

In the project, right click on "INFEED" under "Infeeds" and then select "Expert list".

Table 7- 10 Parameter settings for "INFEED" drive unit

Parameter	Value	Comment
p5540.0	1	Grid monitoring configuration, voltage and frequency monitoring. As a result of the fault ride through function, when dynamic support is activated, the Active Line Module only shuts down (trips) to protect itself. Grid protection (shutdown involving frequency or voltage faults) must be separately activated. Alternative to monitoring with p5540.0, this can also be realized using flexible characteristics (p5540.4, refer above) or externally, using a separate control system.
p5540.1	e.g. 0	Grid monitoring configuration, activating the AISL (anti islanding) frequency shift technique. The frequency shift technique actively changes the injected frequency. When an island grid is created, this causes the permissible frequency band to be violated. A shutdown is realized as a result of fault F06851. Anti-islanding should only be activated if it is actually required!
p5541	1	BI: Grid monitoring activation The parameter for the terminal for activating the dynamic grid support must be entered.
p5543	In accordance with country-specific guideline ¹⁾	Grid monitoring voltage threshold
p5544	In accordance with country-specific guideline ¹⁾	Grid monitoring frequency threshold
p5545[0]	In accordance with country-specific grid codes: Permissible duration of a 100% voltage dip	Voltage and frequency monitoring, minimum shutdown time
p5547[0]	e.g. 0.1 Hz	AISL (anti islanding) frequency shift excitation frequency For frequency changes below the set excitation frequency, a normal grid frequency change is assumed. For frequency changes above the set excitation frequency, the algorithm for island grid detection is activated.
p5548[0]	e.g. 0.1	Sets the gains for the grid monitoring Sets the gain for the frequency deviation for the frequency shift technique.
Parameter assignment for monitoring for grid synchronization		
p5540.9	e.g. 1 ¹⁾	Grid synchronization voltage/frequency check Activates the additional voltage and frequency check when switching on. To do this, before the operating enable, a check is made against limits p5543[2, 3] and p5544[2, 3] and the system waits until these limits are complied with. If voltage and frequency limits are exceeded, then this is indicated in r5542.
p5545[7]	e.g. 60000 ms ¹⁾	Grid synchronization restart check duration Duration of the frequency and voltage check (p5543, p5544) of the grid for automatic restart (p1207 and following).

¹⁾ Values are system-specific and must be taken into special consideration when adapting to the particular system configuration.

7.5 Commissioning example of an infeed with dynamic grid support for a power grid

As an alternative to the grid monitoring with threshold values for voltage and frequency (p5543, p5544) as mentioned above, flexibly adaptable grid protection can be implemented using characteristics, as shown in the subsequent table.

Parameter settings for voltage-time monitoring and frequency-time monitoring

In the project, right click on "INFEED" under "Infeeds" and then select "Expert list".

Table 7- 11 Parameter settings for "INFEED" drive unit

Parameter	Value	Comment
p5540.4	¹⁾	The voltage-time characteristic (HVRT - high voltage ride through, LVRT - low voltage ride through) can only be activated when voltage and frequency monitoring are activated (p5540.0 = 1 signal). The monitoring thresholds in p5543 are deactivated.
p5540.5	¹⁾	FRT (fault ride through) shutdown delayed The response after LVRT (low voltage ride through) limit violation depends on the signal state. 0 signal = immediate shutdown. 1 signal = shutdown only after the time in p5545[2] has expired.
p5540.7	¹⁾	The frequency-time characteristic (HFRT - high frequency ride through, LFRT - low frequency ride through) can only be activated when voltage and frequency monitoring are activated (p5540.0 = 1 signal). The monitoring thresholds in p5544 are deactivated.
p5545[2]	e.g. 3000 ms ¹⁾	FRT LVRT (low voltage ride through) shutdown time
p5545[3]	e.g. 0 ¹⁾	FRT (fault ride through) voltage return wait time
p5545[4]	e.g. 0 ¹⁾	FRT (fault ride through) frequency return wait time
p5550[0]	e.g. 120 % ¹⁾	Sets the activation thresholds for HVRT (high voltage ride through) of a grid fault for FRT (fault ride through) grid monitoring. The setting is made as a percentage of p0210.
p5550[1]	e.g. 80 % ¹⁾	Sets the activation thresholds for LVRT (low voltage ride through) of a grid fault for FRT (fault ride through) grid monitoring. The setting is made as a percentage of p0210.
p5551[0]...p5551[9]	In accordance with country-specific guideline ¹⁾	Sets the time values for HVRT (high voltage ride through) voltage characteristic If the voltage does not return to the permissible tolerance range (p5550[0, 2]) within the monitoring range (p5551[9]) then the system is shut down with fault F06851.
p5552[0]...p5552[9]	In accordance with country-specific guideline ¹⁾	Sets the voltage values for HVRT (high voltage ride through) voltage characteristic. The setting is made as a percentage of p0210.
p5553[0]...p5553[9]	In accordance with country-specific guideline ¹⁾	Sets the time values for LVRT (low voltage ride through) voltage characteristic. If the voltage does not return to the permissible tolerance range (p5550[1, 2]) within the monitoring range (p5553[9]) then the system is shut down with fault F06851.
p5554[0]...p5554[9]	In accordance with country-specific guideline ¹⁾	Sets the voltage values for LVRT (low voltage ride through) voltage characteristic. The setting is made as a percentage of p0210.

7.5 Commissioning example of an infeed with dynamic grid support for a power grid

Parameter	Value	Comment
p5555[0]	e.g. 0.5 Hz ¹⁾	Sets the activation frequency thresholds for HFRT (high frequency ride through) of a grid fault for FRT (fault ride through) grid monitoring. The setting is made as difference to the rated frequency p0211
p5555[1]	e.g. -0.7 Hz ¹⁾	Sets the activation frequency thresholds for LFRT (low frequency ride through) of a grid fault for FRT (fault ride through) grid monitoring. The setting is made as difference to the rated frequency p0211
p5556[0]...p5556[9]	In accordance with country-specific guideline ¹⁾	Sets the time values for HFRT (high frequency ride through) frequency characteristic. If the frequency does not return to the permissible tolerance range (p5555[0, 2]) within the monitoring range (p5556[9]) then the system is shut down with fault F06851.
p5557[0]...p5557[9]	In accordance with country-specific guideline ¹⁾	Sets the frequency values for HFRT (high frequency ride through) frequency characteristic. The setting is made as difference to the rated frequency p0211.
p5558[0]...p5558[9]	In accordance with country-specific guideline ¹⁾	Sets the time values for LFRT (low frequency ride through) frequency characteristic. If the frequency does not return to the permissible tolerance range (p5555[1, 2]) within the monitoring range (p5558[9]) then the system is shut down with fault F06851.
p5559[0]...p5559[9]	In accordance with country-specific guideline ¹⁾	Sets the frequency values for LFRT (low frequency ride through) frequency characteristic. The setting is made as difference to the rated frequency p0211.

¹⁾ Values are system-specific and must be taken into special consideration when adapting to the particular system configuration.

7.5.8 Signal interfaces

Description

The following signals are required by the drive unit for operation and/or provided for monitoring purposes.

Signals transferred to the drive unit

This involves a list of typical signals for communication with the higher-level control system.

Table 7- 12 Signals transferred to the drive unit

Parameter	Drive Object	Signal	Type	Unit
p0840[0]	INFEED	BI: ON/OFF1 Sets the signal source for control word 1 bit 0 (ON/OFF1).	Bit	-
p5501	INFEED	BI: Dynamic grid support activation 1 signal: Activates dynamic grid support. 0 Signal: Deactivates dynamic grid support.	Bit	-
p3511	INFEED	CI: Infeed DC link voltage supplementary setpoint Signal input for control signal of the higher-level external MPP controller	Unsigned32 / FloatingPoint32	-
p3611	INFEED	CI: Infeed reactive current supplementary setpoint Reactive current setpoint for operation with p5501 = 0	Unsigned32 / FloatingPoint32	-
p5480	INFEED	Transformer magnetization mode 0 = deactivated 1 = Normal operation Notice: When magnetization is deactivated, the circuit-breaker is controlled independently of the operating state of any transformer that may be present. This can cause an overload of the line or system components, or may also lead to damage if a transformer is present. Use of an external independent synchronization monitor is recommended.	Integer, 16-bit	-
p5541	INFEED	BI: Grid monitoring activation Signal source to activate grid monitoring 1 signal: Activates grid monitoring. 0 Signal: Deactivates grid monitoring	Unsigned32 / Binary	-

Signals transferred from the drive unit

This involves a list of typical signals for communication with the higher-level control system.

Table 7- 13 Signals transferred from the drive unit

Parameter	Drive Object	Signal	Type	Unit
r0899.0	INFEED	Ready for switching on 1 signal: Ready for switching on 0 signal: Not ready for switching on	Bit	-
r0899.1	INFEED	Ready 1 signal: Ready 0 signal: Not ready	Bit	-
r0899.2	INFEED	Operation enabled 1 signal: Operation enabled 0 signal: Operation not enabled	Bit	-
r0046.0	INFEED	OFF1 enable missing 1 signal: OFF1 enable missing 0 signal: OFF1 enable not missing	Bit	-
r2139.3	INFEED	Fault active 1 signal: Fault active 0 signal: Fault not active The 1 signal is set if a fault occurs in one or more drive objects	Bit	-
r2139.7	INFEED	Alarm active 1 signal: Alarm active 0 signal: Alarm not active The 1 signal is set if an alarm occurs in one or more drive objects	Bit	-
r5502	INFEED	Dynamic grid support status word	Unsigned16	-
r5482	INFEED	Transf magnetization status Status of the transformer magnetization	Integer	-
r0068	INFEED	Absolute current actual value Displays actual absolute current.	FloatingPoint32	Arms
r0070	INFEED	Actual DC link voltage	FloatingPoint32	V
r0072[1]	INFEED	Voltage at the input terminals of the line filter	FloatingPoint32	Vrms
r0082	INFEED	Active power actual value	FloatingPoint32	kW
r0722.0	CU	CU digital inputs, status: DI 0 (X122.1) Feedback signal, circuit breaker (prerequisite is the wiring of the feedback signal with the DI0 of the Control Unit, terminal X122.1)	Bit	-
r5542	INFEED	Line monitoring status word	Unsigned16	-

7.6 Commissioning the grid transformer

7.6.1 Commissioning grid-friendly transformer magnetization

DRIVE-CLiQ topology

The following DRIVE-CLiQ topology must be used so that auto-commissioning will work. If a different DRIVE-CLiQ topology is selected, the user must assign all the VSM10s manually in the offline configuration using the STARTER tool.

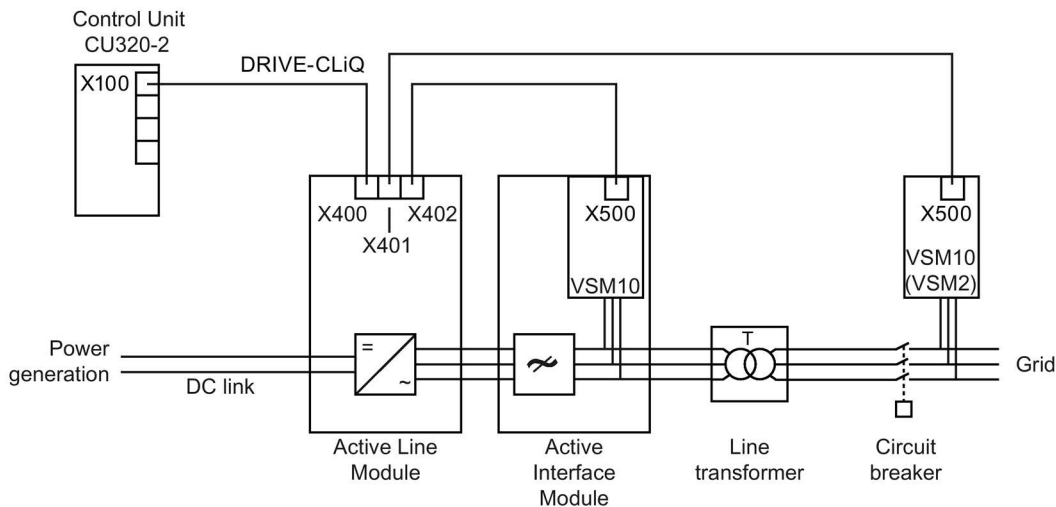

Figure 7-5 DRIVE-CLiQ topology using the chassis format as example

Functional sequence

Magnetization starts after completion of the DC link pre-charging.

With an open circuit breaker between transformer and the grid, the Active Line Module produces an output voltage for synchronous magnetization of the primary side (grid side) of the transformer.

Any residual magnetization of the transformer, or a residual voltage in the line filter, is taken into account during the magnetization process.

Magnetizing sequence:

1. At the beginning of the power-up sequence, r0899.8 is set to "1".
2. On completion of the DC link pre-charging, r0899.11 = 1.
3. During transformer magnetization, r0899.8 = 1 and r0899.11 = 1.
4. After the transformer has been magnetized, the converter has the status "Ready to Operate": r0899.1 = 1 (r0899.8 = 0 and r0899.11 = 1).
5. The feedback signal of the circuit breaker must be interconnected via p0860 in order to facilitate that the transformer magnetization is automatically completed on time (internal

pulse inhibit for the ALM). After the debounce time has elapsed, then controlled ALM operation is automatically assumed.

Note

If, already in the synchronous state, the application requires a long wait time for the circuit breaker to close, then the feedback signal of the switch can be used for the enable p5483.

Parameter r0863.1 (control external line contactor) is used as output to control the circuit breaker. If the function "Grid transformer" is activated (magnetization mode p5480 > 0), the command to close is issued via r0863.1 after the expiry of the premagnetizing ramp and when synchronization is achieved.

Identification of the transformer data

The correct compensation of the voltage drop at the transformer and the optimum control of the voltage at the grid connection point of the island grid by the Active Line Module requires that the magnetizing inductance, leakage inductance and the phase shift of the transformer are taken into account. This transformer-specific data is either provided by the transformer manufacturer, and must be manually entered in the adjusting parameters of the expert list of the Active Line Module of the island grid, or determined using the following measuring routines in the sequence described below.

In the following, the DC link capacitance and, in the case of a connection to a power grid, the grid inductance are identified.

Please note, to measure the phase shift, the leakage inductance and the grid inductance of the connection to the power grid with closed circuit breaker must be known. To manually change the parameters described in the following, using parameter p0010 (infeed commissioning), "quick commissioning" must be selected; whereby this parameter must then be set back to a value of 0 ("Ready").

Circuits and vector groups

The circuit configurations of three-phase transformers are the connections of the winding phases of the input or output side to create star, delta or zigzag connections. These circuit diagrams and the corresponding vector diagrams are shown in the following diagram. The vector group specifies the connection of the phases of two windings of a transformer, as well as the characteristic number for the phase position of the voltage vector. These connection types are identified by the letters specified below:

- Star connection: Y, y
- Delta connection: D, d
- Zigzag connection: Z, z

The uppercase letters designate the connection of the primary winding; the lower case letters, the secondary winding. The upper case letters come first in the vector groups. If the neutral point of a winding is brought out into a star or zigzag connection, then the marking is YN or ZN – or, yn or zn.

The characteristic number (0; 5 etc.) in the vector diagram specifies by which multiple of 30° the vector of the secondary voltage lags with respect to the primary voltage with the associated connection designation. The direction of rotation of the vector is counterclockwise.

The usual vector groups are Yy0 (Yy6), Yz5 (Yz11), Dy5 (Dy11).

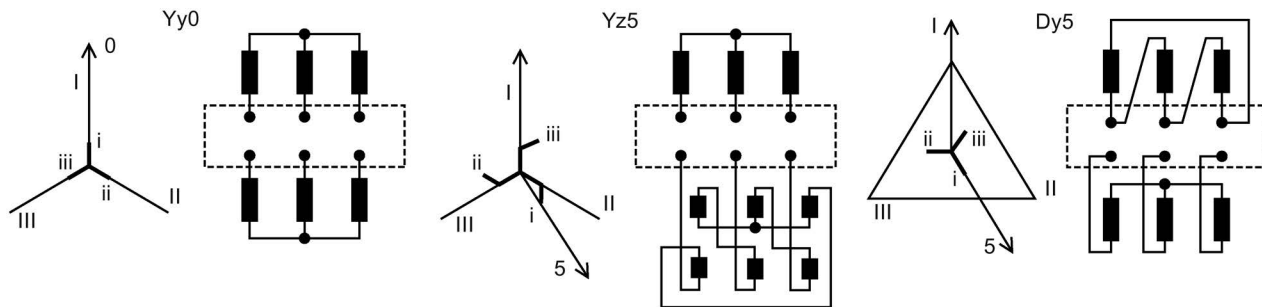

Figure 7-6 Connections and vector groups of three-phase transformers

Identification sequence

1. Before carrying out the measurements, the rated primary voltage (p5486[0]) and the secondary voltage (p0210) of the transformer as well as the effective shift of the phase angle (p6420[0]) must be entered. Even if the phase shift is measured (as described below under 3.), beforehand, the most accurate value possible must be entered into p6420[0]. For a type Dyn5 transformer, the value -150° must be entered in p6420[0]. In order to limit the current flowing into the power grid during the following measurements, parameter p3415 must be set to $p3415[0] = p3415[1] = 5\%$ before switching on for the first time. Depending on the actual system state, it is possible that this parameter may only be able to be changed offline.
2. Magnetizing inductance:
Switching on the Active Line Module of the island grid with p5480 = 11 identifies the magnetizing inductance of the transformer. The alarm displayed is only for information purposes, and does not have to be taken into consideration.
During the measurement, it must be ensured that the DC link is supplied with power. For this particular measurement, the circuit breaker is not closed; a connection to the power grid on the island grid side is therefore not necessary.
The measured value of the main inductance, that was written to r5491 by the system after the measurement had been completed, must be manually entered into p5492. To manually change parameter p5492, using parameter p0010 (infeed commissioning), "quick commissioning" must be selected; whereby this parameter must then be set back to a value of 0 ("Ready").
3. Phase angle shift:
Switching on the Active Line Modules of the island grid with p5480 = 12 identifies the total effective phase shift, and determines a correction value for the effective transformation ratio. Measured values r6440 and r6441 must be transferred into adjustable parameters p6420[0] (phase shift of the voltage between the island grid and grid filter voltage) and p6421[0] (correction value for the effective ratio, e.g. using measuring transformers).
The system closes the circuit breaker for this measurement. Parameter p5480 must then be reset to 0 ("deactivated").

4. DC link capacitance and grid inductance:
Parameter p5580 (island grid black start mode) must be set to p5580 = 0. Switching on the Active Line Modules with p3410 = 5 executes an identification of the line inductance and DC link capacitance. The displayed alarm is for information purposes only, and is of no further significance.
Based on the measured values, the controller is automatically optimized, and the settings saved in a non-volatile fashion. To do this, the circuit breaker is closed, the converter goes completely into operation and as test impresses a defined reactive current at the connection point to the external grid.
After the measurement, parameter p3410 is automatically reset. The Active Line Module must be manually switched off (p840.0 = 0), after the alarm mentioned above has been hidden, and the "OK" message displayed.
5. Leakage inductance:
Switching on the Active Line Modules with p5480 = 13 identifies the effective total leakage inductance of the transformer. The measured value r5489 should be transferred into adjustable parameter p5490. To manually change parameter p5490, using parameter p0010 (infeed commissioning), "quick commissioning" must be selected; whereby this parameter must then be set back to a value of 0 ("Ready").
6. Control parameter p5480 to identify the transformer data must, after the measurements have been completed, be manually set to "0 = deactivated" or "1 = Normal operation".

Note

- Changing amplitude, frequency and angular position can result in undesirable behavior/response of the other components in the island grid.
- Influencing loads/consumers in the island grid:
The ramp times for voltage, frequency and phase angle must be selected, so that loads/consumers are neither overloaded nor tripped as a result of a fault (p5586[1...6]).
- Frequently, the correct parameterization of the phase shift (p6420[0, 1]) results in problems. A check without using additional measuring equipment is only possible if the circuit breaker to the island grid or to the external grid is closed.
For instance, the first case can be created using a black start. When the circuit breaker is closed, then the following must apply: r5498[0, 1, 2] = r5488[0, 1, 2] or r5498[0, 1, 2] = r5488[3, 4, 5].
The time-variant variables can be compared using a trace, for example. If it is not possible to close the circuit breaker in a no-voltage state and subsequently establish a voltage (e.g. when switching between an island grid and power grid) then an oscilloscope with differential voltage probes can be used to check whether the voltages at both sides of the circuit breaker match before the close command.

Note

To avoid saturation effects in the transformer during magnetization (especially for high modulation depth r0074), we urgently recommend the DC component control is activated using p3650.

Operation on weak grids

A "weak grid" is involved if the system fault level (RSC = relative short circuit power) at the connection point is less than 10. For instance, this is frequently the case if the rating of the feeding grid transformer is less than the connection value of the Active Line Module. In this case, the dynamic control operations must be reduced:

- Prior to switching on for the first time, set the following parameters:
p3560 = 50 %, p3615 = 50 %, p3603 = 0 %, p3415[0] = p3415[1] = 5 %.
- If the controller dynamics without feedforward control is not sufficient for the load duty cycle of the respective application (e.g. due to abrupt load changes), the feedforward control p3603 may be increased up to 50%
Large step-like load changes should be avoided for very soft grids.



⚠ DANGER

Danger to life due to electric shock and fire hazard caused by overcurrent protective equipment tripping too late

Overcurrent protective equipment that trips too late or not all can cause electric shock or fire.

- To protect personnel and for fire protection purposes, at the infeed point, the short-circuit rating and loop impedance must match the technical data in the documentation so that the installed overcurrent protective equipment can trip within the specified time.
- If the minimum short-circuit current specified in the technical data cannot be achieved, then additional protective measures must be implemented on the plant side.

Grid filter and transformer monitoring

Parameters p3678 and p3679 are used as adjustable parameters for the monitoring. Using these parameters, threshold value and monitoring time are set for the line filter monitoring. When exceeded, the safety monitoring is initiated and fault F6855 output (Infeed: line filter monitoring responded).

Ratio of the power ratings of the grid transformer to the power rating of the Active Line Module

The setting of the DC component controller must be observed (p5436) especially in cases where the rating of the grid transformer differs from the rating of the grid converter (for active grid droop control p5436, otherwise p3650).

Island grid with special topologies

Grid without circuit breaker

If, in an individual case, the circuit breaker between the Active Line Module/Active Interface module and grid can be eliminated, or if the circuit breaker is not controlled from the SINAMICS system, and it can be guaranteed that the voltage is the same at both sides of the switch using the appropriate external systems, then island grid operation can also be implemented without having to use a 2nd VSM.

Then, only the voltage measured values of the VSM at the Active Interface Module are available. Contrary to the factory setting, this especially means

p5487[0] = r3661

p5487[1] = r3662.

Grid without isolating transformer

An isolating transformer is always required between an Active Line Module/Active Interface Module and an island grid. The transformer can also be eliminated, if, in the island grid, an N conductor is not required, and all loads/consumers and cables in the island grid are designed for the pulse-frequency potential steps of the particular grid with respect to ground potential. Further, for the filter monitoring (p3678) an inductance with $uk \geq 5\%$ is required between the filter and the grid. The transformer can also be replaced by a reactor, for example. Without filter monitoring, it is not permissible to clear short-circuits and p5458[1] must be set = 0.01 s. These conditions must be checked on a case-by-case basis. If necessary, please contact customer support.

The transformer data identification steps (p5480 = 11, 12) are no longer possible. If the default values for the DC component control (p5492, p5436) are not suitable, then suitable settings must be individually determined based on the island grid properties.

Note

When parameterizing the island grid, for operation without a transformer, a 1:1 transformer must be selected (p5486[0] = p0210).



DANGER

Danger to life due to fire when the insulation in the island grid is overloaded when an isolating transformer is not used

Overloaded insulation of loads and cables in the island grid as a result of pulse-frequency potential steps in the kV range can cause electric shock or fire.

- Carefully ensure that the loads/consumers and cables in the island grid have been designed for pulse-frequency potential steps in the kV range with respect to ground potential.

7.6.2 Overview of important parameters

Grid-friendly transformer magnetization

- p5480 Transformer magnetization mode
- p5481[0...2] Transf magnetization times
- r5482 Line synchronization state
- p5483 BI: Line circuit breaker enable
- p5484[0...2] Transf magnetization controller dynamic performance
- p5485[0...1] Transf magnetization voltage thresholds
- p5486[0...1] Transf rated voltage primary
- p5487[0...3] CI: Transf primary voltage signal source
- r5488[0...5] CO: Transformer secondary voltage transformed
- r5489 transf leakage inductance identified
- p5490 Transf leakage inductance
- r5491 Transf magnetizing inductance identified
- p5492 Transf magnetizing inductance
- r5493.0...1 CO/BO: Grid circuit breaker control signals
- p5494[0...1] Magnetization scaling values
- r5497[0...1] CO: Transf secondary current
- r5498[0...2] CO: Transf secondary voltage
- r5499.0...6 CO/BO: Grid synchronization status word

PLL2

- p5571 Grid PLL2 activation signal source
- r5572.0...3 CO/BO: Grid PLL2 status word
- p5574[0...1] Grid PLL2 voltage signal source
- p5580 Island grid black start mode
- p5581[0...8] Island grid times
- p5582[0...1] CO: Island grid synchronization setpoint control
- p5583[0...2] BI: Island grid synchronization setpoint sources
- p5584[0...2] Island grid synchronization controller dynamics
- p5585[0...1] Island grid synchronization voltage thresholds
- p5586[0...6] Island grid scaling values
- r6311[0...1] CO: Grid PLL2 frequency
- r6313 CO: Grid PLL2 voltage smoothed
- r6314 CO: Grid PLL2 phase angle

- r6316 CO: Grid PLL2 line phase angle measured
- p6420[0...1] Phase shift input voltage VSM to converter
- p6421[0...1] Line supply voltage sensing gain adaptation
- p6422 Line supply voltage rotating field direction
- p6423 PLL2 dynamic
- p6425 Line voltage active/reactive component smoothing time constant
- r6440 Transformer phase shift identified
- r6441 Transformer gain adaptation identified

Display and parameter assignment of the VSM2 for transformer primary voltage

- p5460 VSM2 input grid connection voltage, voltage scaler
- r5461[0...n] CO: VSM2 input grid connection voltage u1 - u2
- r5462[0...n] CO: VSM2 input grid connection voltage u2 - u3
- r5464[0...n] CO: VSM2 temperature evaluation status
- p5465[0...n] VSM2 temperature evaluation sensor type
- r5466[0...n] CO: VSM2 temperature KTY
- p5467[0...n] VSM2 overtemperature alarm threshold
- p5468[0...n] VSM2 overtemperature shutdown threshold
- p5469[0...n] VSM2 overtemperature hysteresis
- p5470[0...n] VSM2 10 V input CT gain
- r5471[0...n] CO: VSM2 10 V input CT 1 actual value
- r5472[0...n] CO: VSM2 10 V input CT 2 actual value
- r5473[0...n] CO: VSM2 10 V input 1 actual value
- r5474[0...n] CO: VSM2 10 V input 2 actual value

DC component controller

- p3648[0..1] CO: Transformer DC component controller current actual value
- r3649 Transformer DC component controller integral time
- p3650 Transformer DC component controller proportional gain
- p3651 Transformer DC component controller limiting
- r3652[0...1] CO: Transformer DC component controller manipulated variable
- p3654 Transformer DC component controller PT2 limit frequency

Filter monitoring

- p3678[0...1] Filter monitoring threshold values
- p3679[0...1] Transformer filter monitoring times

Others

- p5406[0...1] CI: Line droop control frequency droop supplementary setpoint
- p5416[0...1] CI: Line droop control voltage droop supplementary setpoint

7.6.3 Function block diagrams

- 7987 Negative sequence system controller
- 7988 Island grid black start sequence control
- 7989 Island grid synchronization sequence control
- 7990 Transformation model
- 7991 Line filter monitoring
- 7992 PLL2 (phase-locked loop 2)
- 7993 Transformer magnetization, voltage threshold
- 7994 Transformer magnetization sequence control

7.7 Commissioning the grid droop control

For commissioning the grid droop control, reference is made to Chapter Commissioning example for an infeed with voltage and frequency control for an island grid. (Page 70) and the general function chapter (Function module for grid droop control (Page 35)).

7.7.1 Black start in an island grid

Preconditions

Binector output r0863.1 is used to control the circuit breaker to connect the infeed and island grid.

Grid droop control operation (p5401) must be activated.

Black start sequence

1. r5482 = 1: Black start wait
The system waits for the switch-on command (p0840).
The island grid black start must be activated (p5580 = 2, 3).
Transformer test operation must be deactivated (p5480 ≤ 1).
2. r5482 = 100: Black start grid test
A check is made as to whether the absolute value of the grid voltage of the island grid (r0072[2]) is less than the voltage limit in p5586[0].
3. r5482 = 102: Black start demagnetization ramp runs
The demagnetization ramp is used to dissipate energy that may still be stored in the line filter of the Active Interface Module.
4. r5482 = 103: Black wait for voltage threshold
A check is made as to whether the absolute value of the grid voltage of the island grid (r0072[2]) is less than the voltage limit in p5586[0] within the time in p5581[3].
5. r5482 = 104: Black start wait for circuit breaker enable
The system waits for the circuit breaker to be enabled to connect the infeed with the island grid (p5483) and the grid droop control to be activated (p5401).
The feedback signal must be connected via p0860. The status is indicated in r0863.1.
6. r5482 = 105: Black start wait circuit breaker bounce time
The system waits for the bounce time of the circuit breaker to connect the infeed with the island grid (p5581[1]).
7. r5482 = 106: Black start wait for grid control active
The system waits for the grid droop control to run up (r5402.1 = 1).
8. r5482 = 107: Black start magnetization ramp
The voltage of the infeed is increased up to the rated voltage via a parameterizable run-up time (p5581[0]).
The existing grid droop control is used to compensate for load fluctuations in the island grid.

9. r5482 = 108: Black start complete grid check
It is checked as to whether voltage and frequency of the island grid lie within the permissible tolerance limits ($p0282 < r0072[2] < p0281$ and $p0285 < r0066[1] < p0284$).
10. r5482 = 109: Black start completed

Settings

The island grid black start is configured using p5580.

- 0: Deactivated
- 2: Grid black start:
A black start is executed, precondition is that the grid voltage is less than p5586[0].
- 3: Grid black start automatic:
 - a) When the grid voltage is less than p5586[0] a black start is executed (same as for p5580 = 2).
 - b) When the grid voltage lies between p0281 and p0282 and the frequency between p0284 and p0285, then the infeed is synchronized with the already existing island grid.
 - If neither a) nor b) are fulfilled, then the system waits, and after the time in p5581[2] expires, the switch-on attempt is canceled with fault F6503.

Notes

- Frequently, the grid infeed is connected to the island grid through a transformer. Using the "Black start" function, this transformer is magnetized together with the grid along a ramp. Switching-in a transformer in a no-voltage condition to an island grid already at its specific voltage level generates high inrush currents and grid harmonics, and should therefore be generally avoided.
Using the "Transformer magnetization" function (p5480 = 1) in these cases (no black start) the transformer voltage can be softly increased before normal synchronization of the grid infeed with the grid.
- The "Black start" function requires the same BiCo connections as the "Transformer magnetization" function (p5480). For a black start, together with the magnetization of the grid transformer, the connected island grid is also established.
- The 2nd VSM10 that is mandatory senses the grid voltage at the grid side of the circuit breaker between the infeed and island grid (FP 7990).
The voltage measured values are displayed in parameters r5461[0] / r5462[0] and are used as inputs for the voltage conversion in the transformer model (p5487[0] = r5461[0], p5487[1] = r5462[0]. The transformer ratio (between the island grid and infeed input) is set using p5486[0].
- The phase shift of the voltage between the island grid and the grid filter voltage must be set in parameter p6420[0].
Remaining gain errors (e.g. caused by measuring transformers) can be corrected using parameter p6421[0].
The determination or check can be realized, for example, using a trace or by evaluating parameter r3661 (secondary side of the transformer) and r5461[0] (primary side of the transformer, island grid).

- Corresponding to function diagram FP7990, different measuring tasks are uniquely assigned to the various VSM10 devices; it is not permissible to change this assignment. For an assignment of the various VSM10, see the diagram in the subsequent chapter, the assignment of the VSM10 to the numbers in the diagram are as follows:
VSM_1 = ③, VSM_2 = ⑥, VSM_3 = ⑩.
 - VSM_1 is, according to a possible parallel connection of power units and grid filters, assigned to p0141 (measured values r3661, r3662).
 - VSM_2 is defined with p0151[0]; the measured values are displayed in r5461[0] and r5462[0].
 - VSM_3 is defined with p0151[1]; the measured values are displayed in r5461[1] and r5462[1].

Overview of important parameters

- p5401 BI: Line droop control activation
- p5483 BI: Line circuit breaker enable
- p5486[0] Transformer rated voltage primary - infeed transformer
- p5487[0, 1] CI: Transf primary voltage signal source - infeed transformer
- p5580 Island grid black start mode
- p5581[0...4] Island grid times - black start
- p5586[0] Black start voltage limit

Function block diagrams

- 7988 Island grid black start sequence control

7.7.2 Synchronizing an island grid to an external power grid

Configuration

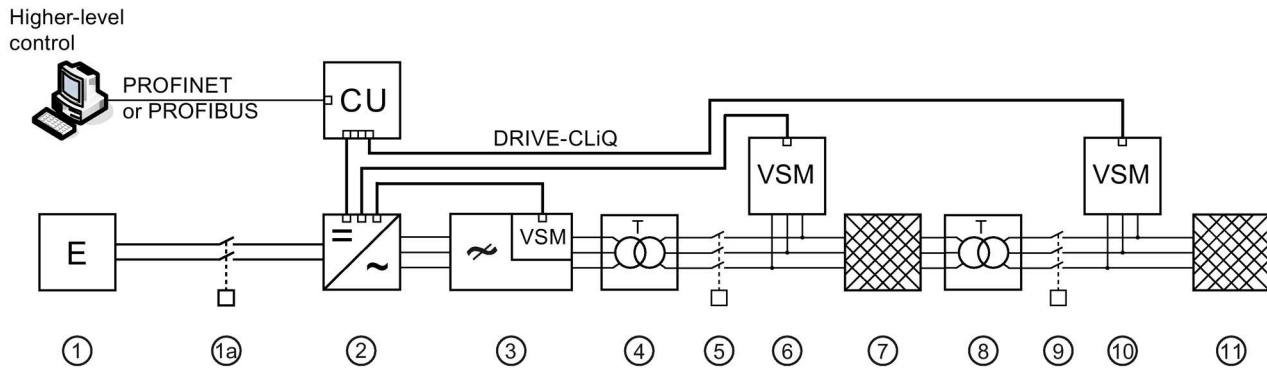

Figure 7-7 Configuration for the infeed in an island grid with coupling to the power grid – example, chassis format devices

Table 7- 14 Components for the infeed in an island grid with coupling to the power grid

Number	Description
1	DC voltage source
1a	Optional DC contactor
2	Active Line Module
3	<ul style="list-style-type: none"> Active Interface Module with integrated Voltage Sensing Module VSM10 (for chassis format) Active Interface Module with additional Voltage Sensing Module VSM10 (for booksize format)
4	Grid transformer
5	Circuit breaker to connect the infeed to the island grid
6	Voltage Sensing Module VSM10 to measure the grid voltage of the island grid
7	Island grid
8	Island grid transformer
9	Circuit breaker to connect the island grid to the power grid
10	Voltage Sensing Module VSM10 to measure the grid voltage of the power grid
11	Power grid

Preconditions

A 3rd VSM10 is required in order to measure the voltage and frequency of the external grid that is to be connected to the island grid.

Binector output r5493.1 is used to control the external circuit breaker to connect the island grid and external grid after synchronization has been completed. The feedback signal of the circuit breaker must be interconnected with a digital input, which must be appropriately parameterized in parameter p5583[1].

The voltage in the island grid has been established. If required, for this purpose, before the island grid synchronization, a black start of the island grid is carried out.

Synchronization sequence

1. r5482 = 1: Wait
The start is realized using a 1 signal at binector input p5583[0].
The grid control must be active (r5402.1 = 1).
The infeed must be switched-on (the pulses must be enabled).
It is not permissible that the circuit breaker is closed, as the feedback signal is realized using binector input p5583[1].
2. r5482 = 200: Island grid synchronization grid check
A check is made as to whether the external grid maintains the tolerance for voltage and frequency during the time in p5581[7] (see p0281 ... p0285).
3. r5482 = 201: Island grid synchronization U/f ramp
The voltage amplitude and the frequency of the island grid are slowly aligned to the external grid along a parameterizable ramp (p5584[1]) until the deviations of the voltage and frequency are less than the threshold values in p5586[6] and p5586[5].
4. r5482 = 202: Island grid synchronization angular ramp
The frequency of the island grid is temporarily reduced along a parameterizable ramp (p5584[0]) and then increased again until the deviations of angle and frequency are less than the threshold values in p5586[4] and p5586[5].
5. r5482 = 203: Island grid synchronization control
Possibly existing voltage, frequency and angular differences between the island grid and external grid are corrected using an adjustable controller (p5584[0...2]) until the island grid has been synchronized to the external grid.
6. r5482 = 204: Island grid synchronization – wait for circuit breaker feedback signal
Bit p5493.1 is set and the system waits for the circuit breaker feedback signal for the island grid, the feedback signal is realized via binector input p5583[1].
7. r5482 = 205: Island grid synchronization – wait for circuit breaker bounce time
The system waits for the bounce time of the island grid circuit breaker (p5581[5]).
8. r5482 = 206: Island grid synchronization – wait for grid control to become inactive
This state is maintained until the grid control has been deactivated.

Settings

- The maximum time for grid synchronism to be achieved is set using p5481[6].
If, during this time, synchronization is not reached, then the system is shut down with fault F06504.
- The supplementary setpoints (r5582) for voltage and frequency for alignment to an external grid remain active even after synchronization has been completed. With p5583[2], at the same time as adapting the standard setpoints (p5406[0], p5416[0]) the supplementary setpoints can be reset.
Withdrawing the supplementary setpoints must be compensated by appropriately adapting the main setpoints (p5406, p5416).

Additional parameter settings for synchronizing an island grid to an external grid

The following table provides an overview of the most important adjustable parameters with typical values and notes for an application involving synchronizing an island grid to an external grid.

This overview should provide help when commissioning the system. It does not replace the information in the previous chapters or the parameter descriptions and function charts in the List Manual.

Depending on the application, in individual cases, it may be necessary to change parameters, which are not listed in the tables.

Table 7- 15 Parameter settings for "INFEED" drive unit

Parameter	Value	Comment
p5486[1]	e.g. 690 V	<p>Transformer rated primary voltage, island grid transformer</p> <p>The rated voltage of the external grid is specified in p5486[1], with which the island grid is to be occasionally connected to with switch (9). An island grid transformer (8) is provided between the island grid and external grid so that the island grid can be synchronized.</p> <p>It should be noted that when converting the voltage data from the external grid to the connection point of the Active Line Module, the infeed transformer must also be taken into account.</p> <p>Setting the rated primary voltage of the grid transformer, to whose secondary an island grid with Active Line Module in grid droop operation (p5401) is connected. Typically, the primary of this transformer is connected to the power grid or another island grid via a circuit breaker. Setting the primary voltage and setting the device supply voltage (p0210) define the ratio of the island grid transformer.</p>
p6420[1]	¹⁾	<p>Transformer phase shift, island grid transformer</p> <p>Setting the overall phase shift between the island grid transformer and the infeed transformer. There is no automatic identification routine available for this phase shift.</p> <p>When converting the external voltages to the connection point of the Active Line Module (see r5488[3, 4]) it should be noted that the sum of the phase shifts of all intermediate transformers is effective.</p> <p>Note: With the circuit breaker is closed at the infeed transformer and at the island grid transformer, a correct setting of p6420[1] and p6421[1] can be identified by the fact that the characteristics with respect to time of voltages r3468[0, 1] and r5488[3, 4] approximately coincide for low load conditions.</p>
p6421[1]	e.g. 100 % ¹⁾	<p>Transformer gain adaptation, island grid transformer</p> <p>Setting the overall correction factor for the fine calibration of the voltage conversion ratio between the external grid and the connection point of the Active Line Module. There is no automatic identification routine available for this correction factor.</p>
p5487[2]	e.g. INFEED.r5461[1]	<p>CI: Transformer primary voltage signal source - island grid transformer u12</p> <p>Signal source for the measured conductor-conductor voltage at the grid disconnect (9) for internal conversion to the connection point of the Active Line Module.</p> <p>The converted voltage value transformed into space vector coordinates is indicated in r5488[3, 4].</p> <p>The conversion takes into account the ratio between p5486[1] and p0210 as well as phase shift p6420[1] and correction factor p6421[1].</p>

Parameter	Value	Comment
p5487[3]	e.g. INFEED.r5462[1]	CI: Transformer primary voltage signal source - island grid transformer u23 Signal source for the measured conductor-conductor voltage at the grid disconnector (9) for internal conversion to the connection point of the Active Line Module. The converted voltage value transformed into space vector coordinates is indicated in r5488[3, 4].
p5571	INFEED.r5499.5	BI: Grid PLL2 activation signal source Sets the signal source to activate PLL2 for determining the frequency, phase angle and amplitude of an external grid. The synchronization of an island grid (p5493[0]) is realized at the output signals of PLL2 (r6311[1], r6313, r6314).
p5574[0, 1]	e.g. INFEED.r5488[3, 4]	CI: Grid PLL2 voltage signal source To synchronize to an external grid, its frequency, amplitude and phase position must be determined using the supplementary grid PLL2. The converted voltage measured values of the external grid must be used (in this case r5488[3, 4]) as input signals for the PLL2.
p5581[5]	e.g. 1 s	Synchronizing circuit breaker bounce time Setting the bounce time for the circuit breaker on the grid side of the grid transformer.
p5581[6]	e.g. 60 s	Maximum synchronizing time Setting the permissible maximum time. Fault F06504 is output if grid synchronization has not been realized when the maximum time has expired.
p5583[0]	e.g. CONTROL_UNIT.r0722.3	BI: Island grid synchronization signal sources, start Signal source for the start command to synchronize the island grid with an external grid.
p5583[1]	e.g. CONTROL_UNIT.r0722.4	BI: Island grid synchronization signal sources, circuit breaker feedback signal Signal source for the feedback signal the circuit breaker between the island grid and external grid.
p5583[2]	e.g. CONTROL_UNIT.r0722.5	BI: Island grid synchronization signal sources, reset setpoints Signal source to reset supplementary setpoints for voltage and frequency (r5582[0, 1]) after island grid synchronization has been completed. At the same time as the reset command, the external cyclic supplementary setpoints must be appropriately adapted (p5406[0], p5416[0]). Explanation: Synchronization is realized using suitable supplementary setpoints for the grid droop, i.e. the original settings of the grid droop are no longer suitable after the grids have been connected with one another. When resetting the supplementary setpoints from the synchronizing operation, the application must simultaneously correct the old droop settings.
p5586[1]	e.g. 0.5 %	Island grid scaling values, synchronization grid phase angle ramp Setting the maximum permissible frequency deviation (as a percentage of the rated frequency p0211) for aligning the grid phase angle for island grid synchronization.
p5586[2]	e.g. 1 %	Island grid scaling values, synchronization frequency ramp Setting the ramp speed for aligning the line frequency for island grid synchronization (as a percentage of the rated frequency p0211 per second).
p5586[3]	e.g. 1 %	Island grid scaling values, synchronization voltage ramp Setting the ramp speed for aligning the line voltage for island grid synchronization (as a percentage of the rated voltage p0210 per second).

1) Values are system-specific and must be taken into special consideration when adapting to the particular system configuration.

Damping grid oscillations

A good damping is achieved, for example with the setting $p5413 = 50\% \times p5407$ and $p5414 = 10\% \times p5409$.

Damping can be additionally or alternatively increased using DT1 filter $p5476$.

Notes

- Changing amplitude and frequency can result in undesirable behavior/response of the other components in the island grid. The application is responsible for checking the suitability of all of the components.
- **Influencing loads/consumers in the island grid:**
The ramp times for the grid parameters to be synchronized must be selected, so that loads/consumers are neither overloaded nor tripped as a result of a fault ($p5586[1...6]$).
- **Interaction with other power generating units in the island grid:**
The synchronizing grid infeed must be the only generating unit in the island grid that controls the grid voltage and grid frequency. If other power generating units are involved in the voltage and frequency control in the island grid, then the offset values for frequency and voltage ($r5582[0, 1]$) must be communicated with these other power generating units using a real-time-capable communication link.
- The 3rd VSM10 that is mandatory senses the grid voltage at the grid side of the circuit breaker between the island grid and external grid (FP 7990).
The voltage measured values are displayed in $r5461[1]$ / $r5462[1]$ and are used as inputs for the voltage conversion in the transformer model ($p5487[2] = r5461[1]$, $p5487[3] = r5462[1]$). The transformer ratio (between the external grid and the infeed input) is set using $p5486[1]$.
The phase shift of the voltage between the external grid and the grid filter voltage must be set in parameter $p6420[1]$.
The remaining gain errors (e.g. caused by measuring transformers) can be corrected using parameter $p6421[1]$.
- In order to guarantee reliable synchronization of the two grids, reliable values for amplitude, frequency and angular position of the external grid are required.
These variables represent the setpoints for synchronizing the island grid.
A proven technique employs a phase-locked loop, i.e. a control loop for the stable calculation of the variables being searched for from the measured actual values of the external grid voltages.
The "Grid transformer" function module provides a generally usable PLL; the input variable is a measured voltage vector in alpha/beta coordinates.
As a consequence, the following parameter assignments are required:
 - The voltage values of the external grid converted into alpha/beta coordinates are connected with the PLL inputs: $p5574[0, 1] = r5488[3, 4]$
 - PLL2 should be activated at the start of synchronization: $p5571 = r5499.5$
 - The setpoints for voltage, frequency and angular position used for synchronization are displayed in $r6311[1]$, $r6313$ and $r6314$.

- Frequently, the correct parameterization of the phase shift (p6420[0, 1]) results in problems. A check without additional measuring equipment is only possible if the circuit breaker to the island grid or to the external grid is closed.
For instance, the first case can be created using a black start. When the circuit breaker is closed, then the following must apply: r5498[0, 1, 2] = r5488[0, 1, 2] or r5498[0, 1, 2] = r5488[3, 4, 5].
Traces can be used to compare the time-variant variables, for example.
If it is not possible to close the circuit breaker in the no-voltage state and subsequently establish a voltage (e.g. when switching between the island grid and power grid), then an oscilloscope with differential voltage probes can be used to check that the voltages at both sides of the circuit breaker match before the close command is issued.

Overview of important parameters

- r5482 Line synchronization state
- p5486[1] Transformer rated voltage primary - island grid transformer
- p5487[2, 3] CI: Transf primary voltage signal source - island grid transformer
- p5571 BI: Grid PLL2 activation signal source
- r5572 CO/BO: Grid PLL2 status word
- p5574[0...1] CI: Grid PLL2 voltage signal source
- p5581[0...8] Island grid times
- r5582[0...1] CO: Island grid synchronization setpoint control
- p5583[0...2] BI: Island grid synchronization setpoint sources
- p5584[0...2] Island grid synchronization controller dynamics
- p5585[0...1] Island grid synchronization voltage thresholds
- p5586[0...6] Island grid scaling values
- r6311[0...1] CO: Grid PLL2 frequency
- r6313 CO: Grid PLL2 voltage smoothed
- r6314 CO: Grid PLL2 phase angle
- r6316 CO: Grid PLL2 line phase angle measured

Function block diagrams

- 7989 Island grid synchronization sequence control

7.7.3 Overview of important parameters

Grid control

- r0206[0...4] Rated power unit power
- r0207[0...4] Rated power unit current
- p0210 Device supply voltage
- P0211 Rated grid frequency
- p1300[0...n] Open-loop/closed-loop control operating mode

Grid droop control

- p5401 BI: Line droop control activation
- r5402.0...5 CO/BO: Line droop control status word
- p5403[0...1] CI: Line droop control current signal source
- p5404[0...1] CI: Line droop control voltage signal source
- p5405 Line droop control frequency droop no-load frequency
- p5406[0...1] CI: Line droop control frequency droop supplementary setpoint
- P5407 Line droop control frequency droop gradient
- p5408 CI: Line droop control frequency droop gradient dynamic
- p5409 Line droop control frequency droop smoothing time
- r5410 Line droop control frequency droop output
- r5411[0...1] Line droop control frequency droop active power
- r5412 Line droop control line phase angle
- P5413 Line droop control additional frequency droop gradient
- p5414 Line droop control additional frequency droop smoothing time
- p5415 Line droop control voltage droop no-load voltage
- p5416[0...1] CI: Line droop control voltage droop supplementary setpoint
- p5417 Line droop control voltage droop gradient
- p5418 CI: Line droop control voltage droop gradient dynamic
- p5419 Line droop control voltage droop smoothing time
- r5420 Line droop control voltage droop output
- r5421[0...1] Line droop control voltage droop reactive current
- r5422[0...1] Line droop control voltage droop reactive power
- p5423 Line droop control voltage droop reactive power
- p5424 Line droop control supplementary inductance smoothing time
- p5425[0...1] Line droop control voltage control signal source
- p5426 Line droop control voltage control P gain

- p5427 Line droop control voltage control integration time
- p5428[0...3] Line droop control voltage control short circuit
- r5429 Line droop control voltage control output

Black start synchronization

- p5580 Island grid black start mode
- p5581[0...8] Island grid times
- p5582[0...1] CO: Island grid synchronization setpoint control
- p5583[0...2] BI: Island grid synchronization setpoint sources
- p5584[0...2] Island grid synchronization controller dynamics
- p5585[0...1] Island grid synchronization voltage thresholds
- p5586[0...6] Island grid scaling values

General grid control parameters

- r5444[0...1] Line droop control line voltage absolute value
- r5445[0...11] Line droop control voltage alpha/beta component
- r5446[0...1] Line droop control line voltage active/reactive component
- r5447 CO: Line droop control line voltage absolute value
- r5448[0...3] Line droop control line current alpha/beta component
- r5449[0...1] Line droop control line current active/reactive component
- r5450[0...5] CO: Line droop setpoint active
- p5476 Line droop control damping gain
- p5477 Line droop control damping smoothing time
- p5478[0...1] Line droop control current limits
- r5479[0...5] Line droop control current permissible

Modulation depth controller

- p5430[0...1] Modulation depth controller setting
- p5431 Modulation depth controller dynamic response
- p5432[0...1] Modulation depth controller output voltage limits
- r5433 CO: Modulation depth controller output

DC component controller

- p5434 DC component controller lowpass limit frequency
- p5435 DC component controller lowpass damping
- p5436 Direct component controller P gain
- p5437 Direct component controller integration time
- p5438 Direct component controller limiting

Harmonics controller

- p5440 Harmonics controller bandpass filter activation
- p5441[0...3] Harmonics controller bandpass filter gain
- p5442[0...3] Harmonics controller bandpass filter mid-frequency
- p5443 Harmonics controller bandpass filter gain total

Current hysteresis controller

- p5451 BI: Current hysteresis controller operating mode
- r5452.0...3 CO/BO: Current hysteresis controller sequence control status word
- p5453[0...5] Current hysteresis controller overcurrent limit
- p5454[0...5] Current hysteresis controller overcurrent hysteresis width
- p5455[0...5] Current hysteresis controller overcurrent tolerance range
- p5456[0...2] Current hysteresis controller configuration
- p5457[0...2] Current hysteresis controller pulse frequency changeover
- p5458[0...1] Current hysteresis controller minimum time operating state
- p5459[0...3] Current hysteresis controller sequence control state change

Others

- p1241 Vdc_max controller switch-in level
- p1245 Vdc_min controller switch-in level
- p1250 Vdc controller proportional gain

7.7.4 Function block diagrams

- 7982 Line droop, voltage correction
- 7983 Direct component control, harmonics control
- 7984 Modulation depth control
- 7986 Sequence control, overcurrent

7.8 Commissioning of dynamic grid support

For commissioning the dynamic grid support, reference is made to Chapter Commissioning example of an infeed with dynamic grid support for a power grid (Page 86) and the general function chapter (Function module, dynamic grid support (Page 40)).

7.8.1 Commissioning the anti-islanding function

Anti-islanding function is activated by setting parameter p5541 and configuration with p5540.1. The setting of the permissible limit values for frequency and voltage is realized using p5543 and p5544. If the limit values are exceeded, then this is signaled in status word r5542. If the limit values are still exceeded during the wait time p5545[0], then fault F6851 is output.

7.8.2 Commissioning voltage-time monitoring

Activating

The voltage-time monitoring is activated using p5540.4 = 1. The simple threshold monitoring that is otherwise active is deactivated using p5543.

Response when grid faults occur

- The start of a grid fault is identified as soon as one phase of the grid voltage lies above the threshold p5550[0] or below threshold p5550[1].
- The grid fault has ended as soon as all phases of the grid voltage lie below threshold (p5550[0] - p5550[2]) or above threshold (p5550[1] + p5550[2]).
- Both voltage characteristics are monitored during a grid fault.
 - When the HVRT curve is exceeded (voltage increases), then the system is shut down without delay and fault F6851 is output.
 - When the LVRT curve is fallen below (voltage dip), then the system is shut down without delay and fault F6851 is output.
In the case of p5540.5 = 1, the shutdown is only realized after delay time p5545[2] has expired.
This means that other brief voltage dips can, where necessary, be tolerated when the grid returns.
- If the grid voltage does not return within the parameterized fault duration p5551[9] or p5553[9], then the system is shut down and fault F6851 is output. Taking into account the selected hysteresis p5550[2], the lower limit of the tolerance range is (p5550[0] - p5550[2]), the upper threshold is obtained according to the sum p5550[1] + p5550[2].

Example for monitoring the voltage dip

In the following example, the parameterization of a monitoring characteristic is shown for the voltage according to the following diagram.

The individual characteristic required depends on the country-specific grid codes and the specifications of the individual power utility company:

- After a voltage interruption of 200 ms, infeed operation must be maintained in the range above the subsequent limit curve.
- In this example, a grid fault should be detected as soon as the grid voltage falls below 80 % of the rated voltage: p5550[1] = 80 %.
- The end of a fault ride through is detected if all line phase voltages lie within the threshold values defined with p5550[0, 1] and p5550[2] for time p5545[3].
If the voltage falls below p5550[1] again, then a new characteristic monitoring process starts at instant in time p5553[0]

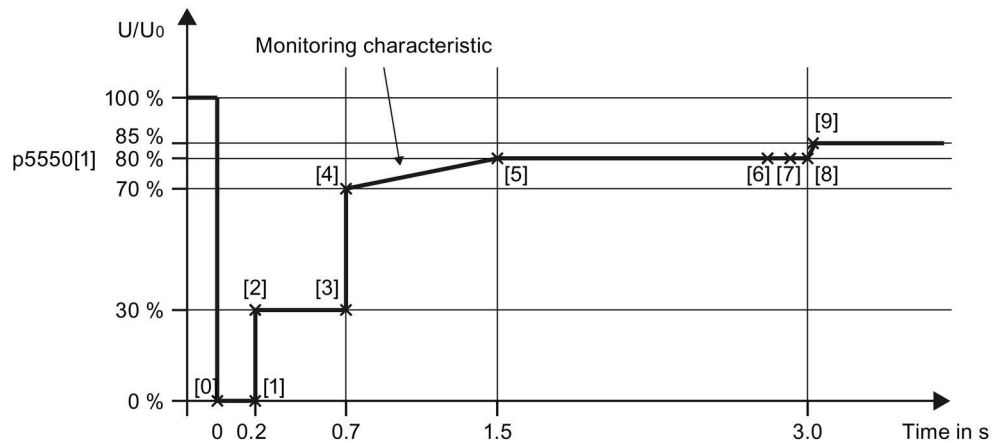

Figure 7-8 Example for voltage-time monitoring

The settings for the LVRT characteristic are described in the following table.

Table 7- 16 Settings for the LVRT characteristic

LVRT time values in s	LVRT voltage values in %
p5553[0] = 0.00	p5554[0] = 0.00
p5553[1] = 0.20	p5554[1] = 0.00
p5553[2] = 0.20	p5554[2] = 30.00
p5553[3] = 0.70	p5554[3] = 30.00
p5553[4] = 0.70	p5554[4] = 70.00
p5553[5] = 1.50	p5554[5] = 80.00
p5553[6] = 2.98	p5554[6] = 80.00
p5553[7] = 2.99	p5554[7] = 80.00
p5553[8] = 3.00	p5554[8] = 80.00
p5553[9] = 3.01	p5554[9] = 85.00

Notes

- The times in p5553[x] must be entered in ascending order. For example, for simply parameterizing steps, the same consecutive times are permissible.
- The time in p5553[9] defines the maximum duration of a fault ride through and must therefore always be defined. Fault F6851 is output if the voltage does not return to the tolerance band within this time. If not all of the interpolation points are required, then the interpolation points before point p5553[9] can be assigned the same voltage values.

7.8.3 Commissioning the frequency-time monitoring

Activating

The frequency-time monitoring is activated using $p5540.7 = 1$. The simple threshold monitoring that is otherwise active is deactivated using p5544.

Response when grid faults occur

- The start of a grid fault is identified as soon as the frequency lies above threshold p5555[0] or below threshold p5555[1].
- The grid fault has ended as soon as the frequency lies below threshold (p5555[0] - p5555[2]) or above threshold (p5555[1] + p5555[2]).
- Both frequency characteristics are monitored during a grid fault.
 - When the HFRT curve is exceeded (frequency increases), then the system is shut down without delay and fault F6851 is output.
 - When the LFRT curve is fallen below (frequency dip), then the system is shut down without delay and fault F6851 is output.
- If the frequency does not return within the parameterized fault duration p5556[9] or p5558[9] then the system is shut down and fault F6851 is output. Taking into account the selected hysteresis p5555[2], the lower limit of the tolerance range is (p5555[0] - p5555[2]), the upper threshold is obtained according to the sum p5555[1] + p5555[2].

Example for frequency-time monitoring

In the following example, the parameterization of a monitoring characteristic is shown for the grid frequency according to the following diagram.

The individual characteristics required depend on the country-specific grid codes and the specifications of the individual power utility company:

- A grid fault involving a frequency increase (HFRT) should be detected as soon as the frequency exceeds the threshold of $p5555[0] = 0.5$ Hz.
- A grid fault involving a frequency decrease (LFRT) should be detected as soon as the frequency exceeds the threshold of $p5555[1] = -0.7$ Hz.
- After the start of a grid fault, the frequency characteristics should be monitored as shown in the following diagram.
- The system is immediately shut down when the upper curve is exceeded or the lower curve is fallen below.

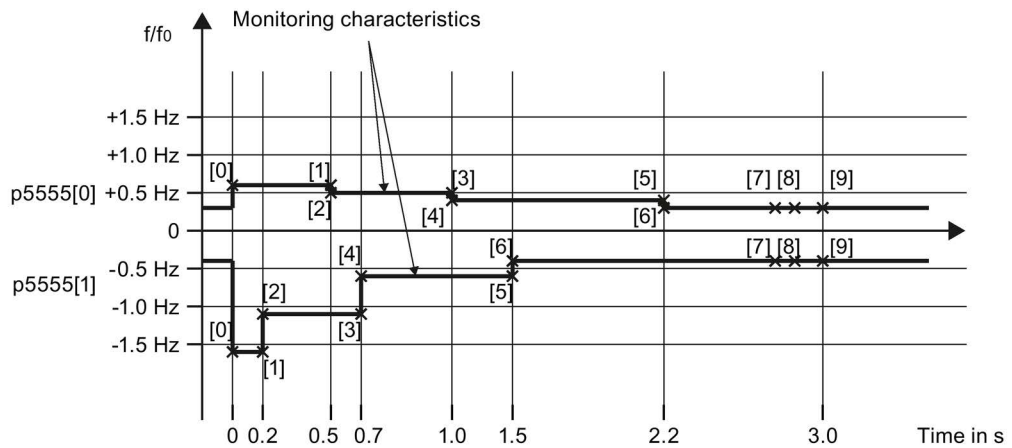

Figure 7-9 Example for frequency-time monitoring

The settings for the frequency-time monitoring are described in the following table.

Table 7- 17 Settings for the frequency monitoring characteristics

Times in s	Frequency values in Hz
Frequency increase (HFRT)	
$p5556[0] = 0.00$	$p5557[0] = 0.6$
$p5556[1] = 0.50$	$p5557[1] = 0.6$
$p5556[2] = 0.50$	$p5557[2] = 0.5$
$p5556[3] = 1.00$	$p5557[3] = 0.5$
$p5556[4] = 1.00$	$p5557[4] = 0.4$
$p5556[5] = 2.20$	$p5557[5] = 0.4$
$p5556[6] = 2.20$	$p5557[6] = 0.3$
$p5556[7] = 2.98$	$p5557[7] = 0.3$
$p5556[8] = 2.99$	$p5557[8] = 0.3$
$p5556[9] = 3.00$	$p5557[9] = 0.3$

Times in s	Frequency values in Hz
Low frequency (LFRT)	
p5558[0] = 0.00	p5559[0] = -1.6
p5558[1] = 0.20	p5559[1] = -1.6
p5558[2] = 0.20	p5559[2] = -1.1
p5558[3] = 0.70	p5559[3] = -1.1
p5558[4] = 0.70	p5559[4] = -0.6
p5558[5] = 1.50	p5559[5] = -0.6
p5558[6] = 1.50	p5559[6] = -0.4
p5558[7] = 2.98	p5559[7] = -0.4
p5558[8] = 2.99	p5559[8] = -0.4
p5558[9] = 3.00	p5559[9] = -0.4

Notes

- The times in p5556[x] or p5558[x] must be entered in ascending order. For example, for simply parameterizing steps, the same consecutive times are permissible.
- The time in p5556[9] or p5558[9] defines the maximum duration of a fault ride through and must therefore always be defined. Fault F6851 is output if the frequency does not return to the tolerance band within this time. If not all of the interpolation points are required, then the interpolation points before point p5556[9] or p5558[9] can be assigned the same voltage values.

7.8.4 Commissioning additional monitoring functions

Some grid codes require that the grid is checked for a defined period of time before switching on the power generating system.

Especially when the automatic restart function is active, the automatic switch-on is prevented until the grid has completely returned.

The activation of the voltage and frequency check before synchronization is indicated using r5542.14.

When the voltage and frequency limits are exceeded, this is displayed in r5542.6 ... r5542.9.

Activating

The monitoring is activated with p5540.9 = 1.

In addition, the corresponding threshold values must be set in p5543[2, 3] and p5544[2, 3]; these thresholds are deactivated in the default setting.

7.8.5 Overview of important parameters

Parameters for dynamic grid support

- p5500 Dynamic grid support configuration
- p5501 BI: Dynamic grid support activation
- r5502.0...4 CO/BO: Dynamic grid support status word
- p5503[0...1] CI: Dynamic grid support current signal source
- p5504[0...1] CI: Dynamic grid support voltage signal source
- p5505[0...3] Dynamic grid support characteristic voltage values
- p5506[0...3] Dynamic grid support characteristic voltage values
- P5507[0...3] Dynamic grid support times
- p5508[0...1] Dynamic grid support Vdc thresholds
- P5509[0...11] Dynamic grid support scaling values
- r5510[0...7] CO: Dynamic grid support output
- r5511[0...1] CO: Dynamic grid support line voltage amplitude
- r5512[0...1] CO: Dynamic grid support line voltage amount
- r5513[0...3] CO: Dynamic grid support line voltage pos/neg sequence system
- r5514[0...1] CO: Dynamic grid support current setpoint alpha/beta
- r5515[0...1] CO: Dynamic grid support active power display
- r5516[0...1] CO: Dynamic grid support reactive power display
- p5518 CI: Dynamic grid support line phase angle signal source
- p5519 CI: Dynamic grid support line frequency signal source
- p5520 CI: Dynamic grid support FRT current limit signal source
- r5522.0...3 CO/BO: Dynamic grid support sequence control status word
- p5523[0...2] Dynamic grid support overcurrent limit
- p5524[0...2] Dynamic grid support hysteresis width
- p5525[0...2] Dynamic grid support overcurrent tolerance range
- p5526[0...2] Dynamic grid support overcurrent modulator configuration
- p5527[0...2] Dynamic grid support changeover pulse frequency
- p5528[0...1] Dynamic grid support minimum time operating state
- p5529[0...3] Dynamic grid support sequence control state change

Parameters for grid monitoring anti-islanding function

- p5540 Line monitoring configuration
- p5541 BI: Line monitoring activation
- r5542.0...14 CO/BO: Line monitoring status word
- p5543[0...3] Line monitoring voltage threshold
- p5544[0...3] Line monitoring frequency threshold
- p5545[0...7] Line monitoring times
- p5547[0] Line monitoring frequencies
- p5548[0] Line monitoring gains
- p5550[0...2] Line monitoring line fault thresholds voltage characteristic
- p5551[0...9] Line monitoring HVRT time values
- p5552[0...9] Line monitoring HVRT voltage values
- p5553[0...9] Line monitoring LVRT time values
- p5554[0...9] Line monitoring LVRT voltage values
- p5555[0...2] Line monitoring line fault thresholds frequency characteristic
- p5556[0...9] Line monitoring HFRT time values
- p5557[0...9] Line monitoring HFRT frequency values
- p5558[0...9] Line monitoring LFRT time values
- p5559[0...9] Line monitoring LFRT frequency values

Others

- p3612 CI: Infeed reactive power precontrol

7.8.6 Function block diagrams

- 7996 Characteristic
- 7997 Current limitation
- 7998 Sequence control
- 7999 Line monitoring anti-islanding

7.9 Commissioning cos phi display

Preconditions

- For the $\cos\phi$ calculation function, when commissioning, the Active Line Module function module "Supplementary module cosinus phi" must be activated. This means that additional parameters p3473 to p3479 are available.
If a second VSM10 is to be used to display $\cos\phi$, then the grid transformer function module should also be activated.
- Precondition for a correct $\cos\phi$ display, is that the Active Line Module and the Voltage Sensing Module operate on the same grid, i.e. with the same grid frequency. It is especially important that parameter r0066 indicates the correct grid frequency and that the Active Line Module is operational. Transformers can be used between the measuring point and the connection point of the Active Line Module; a possibly associated phase shift (interchanged phase sequence) must be parameterized (see p3475).
- Phase currents and conductor voltages at the measuring point are the input variables for the $\cos\phi$ display.
 - Measured values (i1, i2, u12, u23) can be sensed using various devices and fed to the calculation block through a BiCo link (p3473, p3474). Possible deadtimes as a result of signal transfer times/propagation times should be taken into account (see "Calibration parameter p3479" in Section, Application).
 - The VSM10 with 2 measuring inputs for grid voltages up to 3 AC 690 V_{rms} and current-voltage transformers for +/-10 V are suitable for sensing values. Suitable current transformers must be selected and the conversion into current magnitude (p3670) parameterized on an application-for-application basis.
 - In principle, currents or voltages can also be used from the grid model of the Active Line Module control (r3467, r3468) for the $\cos\phi$ display. However, the unavoidable component statistical scatter (especially of the grid filter) can result in a lower display accuracy.

Application

- $\cos\phi$ values for two different connection points at the same grid can be simultaneously sensed and calculated (e.g. an outer $\cos\phi$ at the connection point of the complete system with the grid, and an inner $\cos\phi$ at the inverter terminals). This is the reason that the parameters are indexed 2x.
- Using p3475, two independent $\cos\phi$ displays can be activated (bit 0) and configured.
 - Configuration bit 1 defines whether the input signals for voltage and current are present in space vector coordinates (alpha/beta) – or in a 3-conductor representation (phases R, S, T). As a consequence, signals can be used from internal grid models (e.g. r3467, r3468) – or also direct VSM10 measured values (e.g. r5461, r5471).
 - Configuration bit 2 defines whether between the $\cos\phi$ measuring point (voltages, currents) and the terminals of the Active Line Module, the phase sequence has been interchanged as a result of a transformer.

- Corresponding to the selected configuration, the signal sources for the current and voltage actual values must be parameterized for the $\cos \phi$ measuring point in p3473 and p3474.
- The measured value is displayed as amount (r3478) and sign (r3477). Especially for r3478 = 1, even minimum phase shifts of the currents cause the sign to change. Suitably selecting the smoothing p3476 can prevent undesirable toggling and/or ensure the required response time of the measurement.
- Taking into account all dead times and delay times in the current and voltage measurement is decisive regarding the accuracy of the $\cos \phi$ display. The measurement can be adapted using p3479 if a VSM10 is not used to measure the current, or additional dead times occur as a result of the communication buses.
The $\cos \phi$ calculation can be simply calibrated without using external measuring devices by simultaneously using both $\cos \phi$ displays. The first display r3478[0] uses the current measurement in the Active Line Module as well as the VSM10 voltages at the grid filter. The second display r3478[1] uses the application-specific external measurement of the same currents between the Active Line Module and Active Interface Module, as well as the same VSM10 voltages in 3-conductor coordinates:
 - p3473[0] = r3467[2],
 - p3473[1] = r3467[3],
 - p3474[0] = default,
 - p3474[1] = default,
 - p3475[0] = 1,
 - p3473[2] = e.g. r5471[0],
 - p3473[3] = e.g. r5472[0],
 - p3474[2] = r3661,
 - p3474[3] = r3662,
 - p3475[1] = 3.

When dead time p3479[1] is correctly set, the displays of r3478[0] and r3478[1] are the same in operation.

Calibration accuracy can be increased when required by using separate external reference measuring devices.

Calibration parameter p3479 is preset for current measurement with the 10 V inputs of the VSM10. When correctly calibrated, the $\cos \phi$ display error is typically <0.01 .

Overview of important parameters

- p3473[0...3] CI: cos phi signal source current indication
- p3474[0...3] CI: cos phi signal source voltage indication
- p3475[0...1] cos phi display configuration
- p3476[0...1] cos phi display smoothing time
- r3477[0...1] CO: cos phi display actual value sign
- r3478[0...1] CO: cos phi display absolute actual value
- p3479[0...1] cos phi display current measurement dead time

Function block diagrams

- 8951 Active Infeed - cos phi display

7.10 Commissioning supplementary controls

7.10.1 Commissioning active, reactive and apparent current limiting

Preconditions

- Limits p3528 up to p3533 for active currents in the motoring ($r0078 > 0$) and generating ($r0078 < 0$) directions are a part of the regular Active Line Module control, and are always available.
- Adjustable parameters p3524 up to p3527 are used to limit the reactive and apparent current.
They require that at least one of the following functional modules is activated: Grid transformer, supplementary controls, dynamic grid support.
- Adapted current limits can be parameterized for riding through grid faults using p5509 and p5520. The "Dynamic grid support" function module is required for this purpose.
- In island grid operation with grid control, with respect to the grid, the Active Line Module acts as voltage source; the currents as well as the $\cos\phi$ are defined by the loads/consumers in the grid.
As a consequence, it is only possible to adjust the apparent current limiting (p5478). The "Grid control" function module is required for this purpose.

Application

Without any additional settings, the instantaneous value of the total current (apparent current) is limited to the maximum permissible current r0209. If the vector sum of the active and reactive current exceeds this maximum value, then initially, the reactive component of the current setpoint is reduced to zero. This means that in the case of an overload, the active current has priority over the reactive current.

7.10.2 Active current limiting

The limits for the active current can be set to different values for the two energy flow directions "motoring" and "generating".

If the motoring current limit is reached, then less active current is injected into the DC link than is specified by the active current setpoint. Generally, the DC link voltage would decrease; however, only up to the rectified value ($V_{dc} \approx 1.35 V_{grid}$), which is dependent on the load. Below this DC link voltage, as a result of the design, uncontrolled recharging currents flow, similar to those of a diode bridge circuit. As a consequence, the active current limiting when motoring is only effective under the condition that the DC link voltage is appropriately high.

For example, the active current limiting can be used to reduce the magnitude of the grid current peaks during load cycles (this has the disadvantage of higher DC link voltage fluctuations) - or if the DC link voltage control, at least temporarily, is realized using another component in the DC link.

7.10.3 Reactive and apparent current limiting

The reactive current can be limited, separately for capacitive ($r0075 > 0$) and inductive ($r0075 < 0$) reactive current setpoint (p3525, p3526). Dynamic limits are also possible using the appropriate BiCo interconnection (p3524).

When using the apparent current limit p3527, initially, the reactive component is reduced (possibly down to 0) before the active current setpoint is adapted.

The associated display parameters for current actual values and status signals should be taken from function block diagram FP8945.

Here we would like to make reference to the derating characteristic (SINAMICS Low Voltage Engineering Manual) for continuous operation with $\cos\phi$ not equal to one.

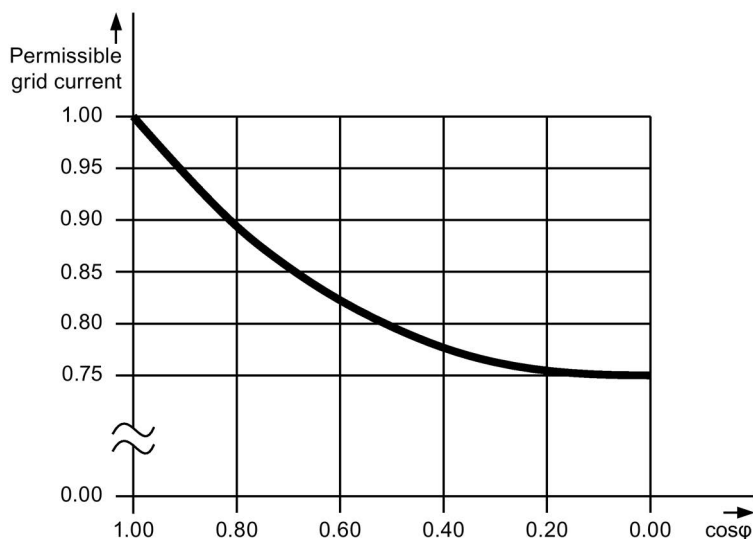

Figure 7-10 Derating characteristic for $\cos\phi$ not equal to one

7.10.4 Current limiting for dynamic grid support

Depending on the grid codes of the power utility company, special requirements apply to power generating systems regarding the current characteristic during a grid fault. Generally, a certain participation in the short-circuit current is specified, i.e. impressing a defined reactive current during a grid fault. When grid support is active ($p5501 = 1$), the reactive current setpoint has priority over the active current, contrary to normal operation. As a consequence, when necessary the active power of the Active Line Module is reduced in order to supply reactive power to the grid according to $p5506$.

The settings of the following parameters are valid when the "Dynamic grid support" function is activated ($p5501 = 1$):

- $p5509[5]$: Additionally effective apparent current limit.
- $p5509[7]$: Additionally effective reactive current limit when the tolerance range for voltage dissymmetry is exceeded ($r5502.2 = 1$).
With the setting $p5509[7] = 0.1 \%$, for example, the grid-supporting reactive current can be deactivated according to the characteristic ($p5506$) for non-symmetrical grid faults.
- $p5509[8]$: Additionally effective limit for the apparent current of the negative sequence system when the tolerance range for voltage dissymmetry is exceeded ($r5502.2 = 1$).
For the setting $p5509[8] = 0.1 \%$, the non-symmetrical support current is prevented, which is actually necessary for non-symmetrical grid faults. Most grid codes specify this.
- $p5509[10]$: Additionally effective active current limit when the tolerance range for the grid voltage is exceeded ($r5502.1 = 1$).
This means that the active power of the power generating system can be reduced when the grid voltage manifests a deviation.
- $p5520$: Additionally effective dynamic apparent current limit when the tolerance range for the grid voltage is exceeded ($r5502.1 = 1$).
This allows application-specific apparent current characteristics to be implemented during grid faults.
- $p5500.6 = 1$: Additionally effective internal apparent current limit when the tolerance range for the grid voltage is exceeded ($r5502.1 = 1$). The value corresponds to the smoothed apparent current before the grid fault.
Corresponding to individual grid codes, this means that the total current can be kept constant before and during a grid fault.
- $p5500.8 = 1$: During a grid short-circuit ($r5502.4 = 1$, $r5522.3 = 1$) the active current setpoint is internally set to zero.
Corresponding to the directives of individual grid codes, a fault ride through (FRT) can be executed with pure reactive power output (Q mode).
- $p5500.9 = 1$: During a grid short-circuit ($r5502.4 = 1$, $r5522.3 = 1$) the active current setpoint and the reactive current setpoint are internally set to zero.
Corresponding to the directives of individual grid codes, a fault ride through (FRT) can be executed without power output (Z mode).

- The priority for providing reactive power for dynamic grid support can be briefly automatically deactivated if the DC link voltage comes close to the upper shutdown limit. In order to avoid a protective shutdown, the reactive current is reduced via p5508 – and the full active power is available to reduce the DC link voltage down to zero.
- For the previously mentioned conditional current limits, a differentiation is made between
 - the permissible tolerance range of the grid voltage (symmetrical and non symmetrical)
 - status signals: r5502.1, r5502.2
 - adjustable parameters: p5505[0, 2], p5509[9, 10]
 - and the detection of a grid short-circuit due to undervoltage
 - status signals: r5502.4, r5522.3
 - adjustable parameters: p5529[2, 3].

Supplementary notes/setting recommendations for the parameterization:

- If, after the grid returns, active power must be quickly re-established (for instance, China), then the "Minimum time dynamic grid support" p5507[0] must be set = 10 ... 20 ms.
- If the permissible time to establish the reactive current after the start of a grid fault is long enough, then the starting ramp for the support current should be reduced (e.g. p5509[0] = 10 %). This can avoid overvoltages at the start of a fault.
- In many cases, during a grid fault, it is not permissible that the reactive current is reduced, if the DC link voltage reaches its shutdown limits (e.g. p5508 = -40 V). To do this, set p5509[1] = 0.1 %.
- If reactive current support is also required for non-symmetrical grid faults (e.g. China GB/T 19964:2012), then the setting p5509[7] = 100 % is necessary. Further, for riding through all fault types, we recommend p5509[8] = 0.1 % as well as p5509[11] = 20 ... 50 %. When required, lower and higher values are also possible. The permissible total current must then be selected to be appropriately high (p5509[5] > 70 %).
- For weak grid conditions, which are typical for test laboratories, we further recommend: p3603 = 0 ... 50 %, p5507[3] = 8 ms, p5509[6] = 3 %.
- For operation on power grids with a stable frequency characteristic, for dynamic support, a longer smoothing time for the PLL is recommended: p3458[1] = 50 ms.

7.10.5 Apparent current limiting for grid droop control

In grid control operation (p5401 = 1) with respect to the grid, the Active Line Module acts as voltage source. This is responsible for maintaining and controlling grid voltage and frequency, and to provide the power required for the various loads/consumers. For an Active Line Module overload condition, the grid control must be adapted by the higher-level power controller so that a sensible and stable load distribution is achieved in the island grid.

The Active Line Module protects itself against overcurrents by limiting the apparent current (or the total current). When the limit is reached, the output voltage and frequency are automatically adapted so that no inadmissible currents flow.

The apparent current limit can be separately set for normal operation and clearing short circuits using p5478.

Typically, for normal operation, a lower current limit is selected (characterized by relatively low grid voltage dip). For instance, this allows heavy-duty drives to be started in island grids to be supplied: the current limit results in a decreased output voltage (in addition to the grid droop function) and therefore to a slower start and a reduction of the currents to a level that can be realized by the Active Line Module for the duration of the heavy load.

In the short circuit state for single generator operation (status signal r5402.4 = 1, threshold values p5459[2, 3], single generator operation p5451 = 0) current limit p5478[1] is effective, and facilitates briefly increased maximum currents (time limit p5458[1]), to support clearing a grid short-circuit.

7.10.6 Notes for Active Line Modules of the Booksize format

In grid control operation, the short-circuit current p5478[1] is limited to 100 % of the maximum current (r0209) (presetting, 90 %).

For active dynamic grid support, the Active Line Module apparent current p5509[5] is limited to 80 % of the maximum current r0209.

The reactive current presetting for dynamic grid support is zero (p5506[..] = 0). The same is true for the active and negative sequence currents during a grid fault (p5509[7] = p5509[8] = p5509[11] = 0). Using these pre-settings, a grid fault is ridden through in an almost no-current condition.

The local Siemens office can be contacted regarding any deviation from the presetsings.

7.10.7 Overview of important parameters

Parameters for the Vdc actual value filter 5

- p1656 Signal filter activation
- p1677 Vdc actual value filter 5 type
- p1678 Vdc actual value filter 5 denominator natural frequency
- p1679 Vdc actual value filter 5 denominator natural frequency
- p1680 Vdc actual value filter 5 numerator natural frequency
- p1681 Vdc actual value filter 5 numerator damping

Parameters for the output voltage setpoint filter 5

- p5200 Signal filter activation
- p5201 Output voltage setpoint filter 5 type
- p5202 Output voltage setpoint filter 5 denominator natural frequency
- p5203 Output voltage setpoint filter 5 denominator damping
- p5204 Output voltage setpoint filter 5 numerator natural frequency
- p5205 Output voltage setpoint filter 5 numerator damping

Parameters for current actual value filter 7

- p5211 Current actual value filter 7 type
- p5212 Current actual value filter 7 denominator natural frequency
- p5213 Current actual value filter 7 denominator damping
- p5214 Current actual value filter 7 numerator natural frequency
- p5215 Current actual value filter 7 numerator damping

Others

- p3612 CI: Infeed reactive power precontrol

7.10.8 Function block diagrams

- 8940 Controller modulation depth reserve / controller DC-link voltage (p3400.0 = 0)
- 8946 Current pre-control / current controller / gating unit (p3400.0 = 0)

7.11 Notes for commissioning systems for operation on grids with low short-circuit power (fault level) and variable grid parameters

Especially in island grids, test grids or when connecting to long grid cables, frequently – in comparison to the Active Line Module rated power – there is a low grid short-circuit power available (e.g. RSC values < 10). Such a "weak" grid manifests a high inductance at the Active Line Module connection point. The resonance properties of the system from the grid and Active Interface Module change significantly and require that the control is appropriately adapted.

Using the grid data identification (p3410 = 4 or 5), normally, the necessary controller adaptations are automatically made. This control optimization increase the ruggedness of the control for weak grids, and increases rise and correction times.

Additional measures may be required in extreme cases:

- The measuring current is reduced if the automatic control optimization becomes unstable, and is canceled with an overvoltage and/or overcurrent fault: Set p3415[0] = p3415[1] = 7 % and repeat the optimization with p3410 = 5.
- The gain factors for the grid current control and the DC link voltage control can be reduced; in addition, the current precontrol can also be reduced. These measures especially apply to applications with relatively low requirements placed on the dynamic performance of the control systems without step-type load surges.

Typical settings include, for example

- p3560 = 25 % ... 50 % (small DC links, e.g.: 1 Active Line Module + 2 Motor Modules chassis format)
- p3560 = 100 % ... 150 % (large DC links, e.g.: 4 Active Line Module + 4 Motor Modules chassis format)
- p3603 = 25 % ... 50 %
- p3615 = 50%

Especially for time-variable grid conditions, the controller can also be adapted dynamically and in time synchronism via BiCo signal inputs (p3561, p3604, p3616).

- For operation on weak grids, frequently, the system – comprising inverter, grid filter and the grid – manifests a resonance point at approximately 1/4 of the Active Line Module controller frequency (0.25 / p0115[0]). For analysis, for example, high resolution traces and FFT calculations of the phase currents (r0069) and filter voltages (r3661, r3662) can be carried out.
To dampen the resonance, a bandstop filter can be configured for the Active Line Module output voltage (p5201 ff). When required, a bandstop filter can be activated for the current actual values (p5211 ff). All bandstop filters are preconfigured for a blocking (trap) frequency of 1000 Hz.
- Normally, the Vdc controller of the Active Line Module corrects/cancels any DC link voltage oscillations. If this is not possible as a result of the oscillation frequency, or is not desirable for a specific application, then a bandstop filter can be configured for the Vdc actual value (p1677 ff).

Device overview

8.1 Control Units

A description for the CU320-2 PN and CU320-2 DP Control Units is provided in Control Units and Additional System Components Manual (<http://support.automation.siemens.com/WW/view/en/99679173>).

8.2 Voltage Sensing Module VSM10

You can find a description of the VSM10 Voltage Sensing Module in the Control Units and Additional System Components Manual (<http://support.automation.siemens.com/WW/view/en/99679173>).

8.3 Active Interface Modules, air-cooled

8.3.1 Booksize format

Active Interface Modules are line-side interfaces for the Active Line Modules.

They contain the following functional units:

- Line reactor
- Low-frequency/switching frequency filters
- Line filters to EN 61800-3, category C3, max. total motor cable length 350 m (shielded)
- Reduction of the stress on the motor insulation from system-dependent resonance factors

In conjunction with an Active Line Module and an EMC-compliant configuration the following radio interference voltage categories are achieved:

- EN 61800-3 category C3 without an additional line filter up to a total cable length of 350 m (shielded) for 16 kW, 36 kW, 55 kW, 80 kW and 120 kW components
- EN 61800-3 category C2 with an additional Basic Line Filter up to a total cable length of 350 m (shielded) for 16 kW, 36 kW, 55 kW, 80 kW and 120 kW components
- EN 61800-3, category C3, with an additional Basic Line Filter up to a total cable length of
 - 630 m (shielded) for 16 kW and 36 kW components
 - 1000 m (shielded) for 55 kW, 80 kW and 120 kW components.

8.3 Active Interface Modules, air-cooled

The Active Interface Module is fitted with a fan. The 24 V supply is essential for operating the component. The temperature signaling contact must also be connected to the Active Line Module.

You can find a description of the air-cooled Active Interface Modules in the Booksize power units manual (<http://support.automation.siemens.com/WW/view/en/99687925>).

8.3.2 Chassis format

Active Interface Modules are used in conjunction with the Active Line Modules in chassis format. The Active Interface Modules contain a Clean Power Filter with basic RI suppression, the pre-charging circuit for the Active Line Module, the line voltage sensing circuit and monitoring sensors.

Frame size GI is equipped as standard with a bypass contactor, which ensures a highly compact design. The bypass contactor must be provided separately for frame sizes HI and JI.

The vast majority of line harmonics are suppressed by the Clean Power Filter.

The Active Interface Module contains:

- Clean Power Filter
- Line reactor
- Pre-charging circuit
- Bypass contactor (for frame size GI)
- Grid voltage sensing module VSM10
- Fan

You can find a description of the air-cooled Active Interface Modules in the Air-cooled chassis power units manual

(<http://support.automation.siemens.com/WW/view/en/92323898>).

Note

Modified grid connection voltage

The permissible grid connection voltage of the Active Interface modules for 3 AC 380 ... 480 V for operation for the grid infeed is:

3 AC 320 V -10 % (-15 % < 1 min) ... 3 AC 480 V +10 %

UL approval is only applicable for the restricted voltage range 380 V -10 % (-15 % < 1 min) ... 3 AC 480 V +10 %, which, for this reason, is specified together with the UL approval on the type plate.

Note

The general data in the SINAMICS Low Voltage Engineering Manual should be carefully observed.

Especially for island grids and weak grids, a grid analysis should be performed with the following content:

- Analysis of the complete drive system, including diesel engines, with statements regarding the total harmonic distortion factor (T_{HD}) – along with the aptitudes of the individual harmonics as a function of the customer's grid parameters. The necessary operating modes must be taken into account.

As a result of this analysis, it may be necessary to make adaptations to the drive system, especially the Active Interface Module.

These adaptations cannot be carried out by the region/customer, but by the manufacturer's factory. Further, these adaptations are not part of the analysis.

The application support group in head office sales can provide support when simulating and performing the grid analysis.

8.4 Air-cooled Active Line Modules for the grid infeed, chassis format

8.4.1 Description

The self-commutating infeed / regenerative feedback units act as step-up converters and generate a stabilized DC link voltage that is 1.5x greater than the rated line supply voltage. In this way, the connected Motor Modules are isolated from the line voltage. This improves the dynamic response and control quality because line tolerances and fluctuations do not affect the motor voltage.

If required, the Active Line Modules can also provide reactive power compensation.

Especially for photovoltaic applications, the 3 AC 320 V ... 480 V Active Line Modules have an AC connection voltage range up to 320 V and a very wide DC voltage range. The technical data includes supplements for operation with connection voltages 3 AC 320 V.

Table 8- 1 Overview of Active Line Modules for line infeed

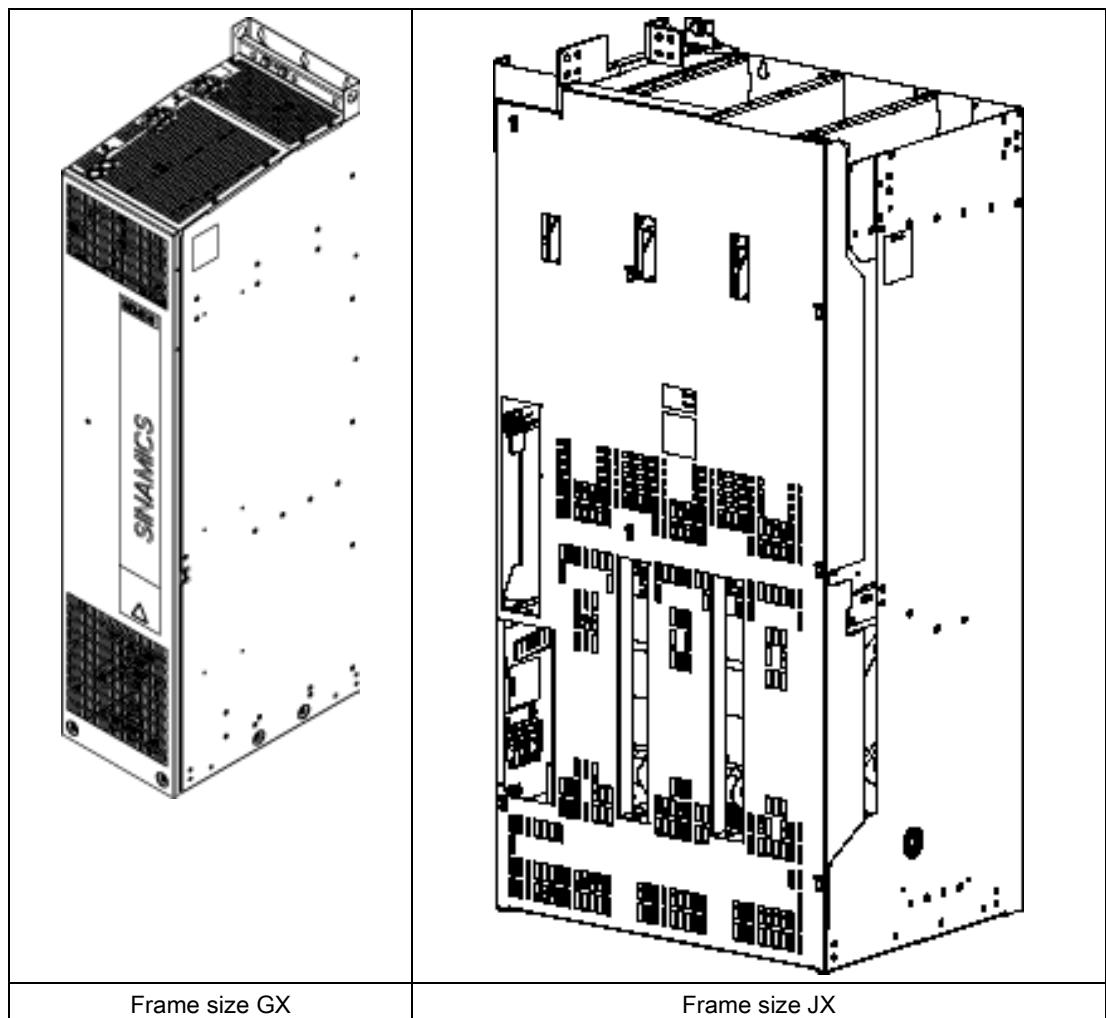

Active Infeed components

An Active Infeed comprises an Active Interface Module and an Active Line Module.

The bypass contactor is fitted in the relevant Active Interface Module on Active Infeeds which feature an Active Line Module of frame size GX. The Active Interface Modules and Active Line Modules of this frame size have degree of protection IP20.

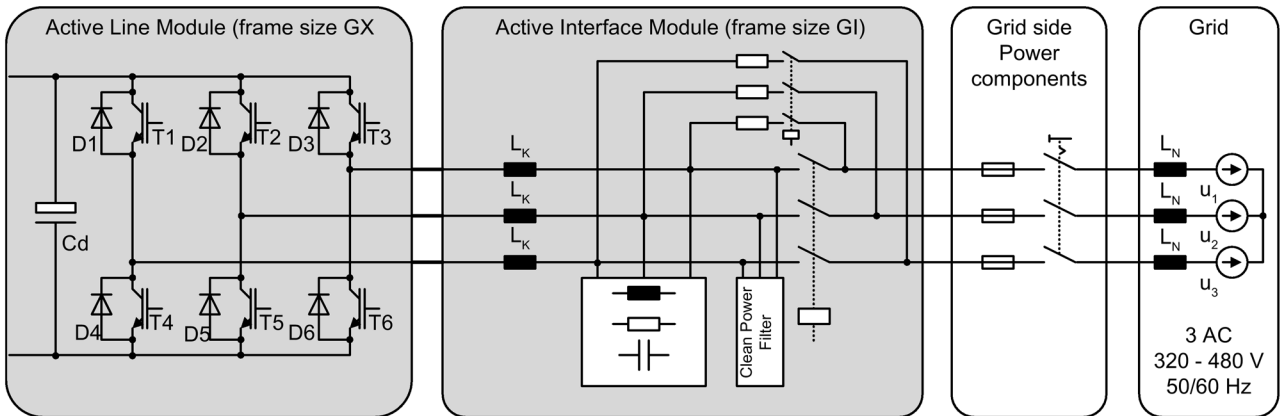

Figure 8-1 Overview of Active Infeeds, frame sizes GI/GX

In the case of an Active Infeed with an Active Line Module of frame size JX, the bypass contactor is not included in the associated Active Interface Module, but must be provided separately. The Active Interface Modules and Active Line Modules of this frame size have degree of protection IP00.

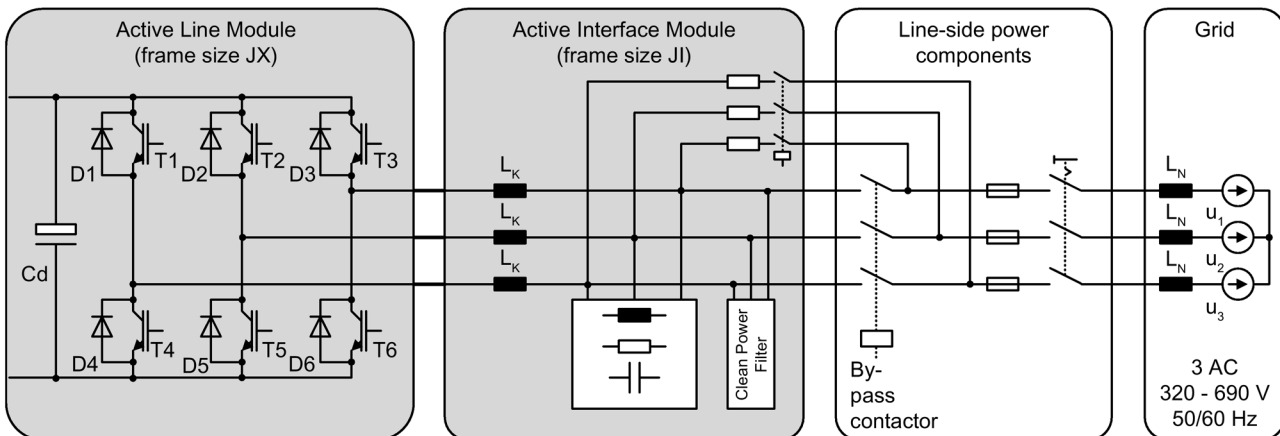

Figure 8-2 Overview of Active Infeeds, frame size JI/JX

Parallel connection of Active Line Modules to increase power rating

To increase the power and for redundancy, it is possible to connect up to four Active Line Modules each with the same output rating and type in parallel.

The following rules must be observed when connecting Active Line Modules in parallel:

- Up to 4 identical Active Line Modules can be connected in parallel.
- A common Control Unit is required whenever the modules are connected in parallel.
- With multiple infeeds, power must be supplied to the systems from a common infeed point (i.e. different supply systems are not permitted).
- A derating factor of 5% must be taken into consideration, regardless of the number of modules connected in parallel.

Note

It is only possible to connect identical power units in parallel if both power units have the same hardware version.

8.4.2 Safety information

 **WARNING**

Danger to life if the fundamental safety instructions and remaining risks are not carefully observed

If the fundamental safety instructions and remaining risks in Chapter 1 are not observed, accidents involving severe injuries or death may occur.

- Adhere to the fundamental safety instructions.
- When assessing the risk, take into account residual risks.

 **DANGER**

Danger to life due to electric shock and fire hazard caused by overcurrent protective equipment tripping too late

Overcurrent protective equipment that trips too late or not all can cause electric shock or fire.

- To protect personnel and for fire protection purposes, at the infeed point, the short-circuit rating and loop impedance must match the specifications in the documentation so that the installed overcurrent protection devices trip within the specified time.

 **DANGER**

Danger to life through electric shock due to a high DC link voltage

As long as the Line Module is connected to the line supply, the DC link is charged with a high voltage. Contact with components can result in death or serious injury.

- Isolate the Line Module from the line supply during installation and maintenance work, e.g. via the line contactor or main switch.

 **DANGER**

Danger to life through electric shock due to the residual charge of the DC link capacitors

Because of the DC link capacitors, a hazardous voltage is present for up to 5 minutes after the power supply has been switched off.

Contact with live parts can result in death or serious injury.

- Only open the device after 5 minutes have elapsed.
- Measure the voltage before starting work on the DCP and DCN DC link terminals.



 WARNING
<p>Danger to life due to high leakage currents caused by an interrupted external protective conductor</p> <p>The drive components conduct a high leakage current via the protective conductor. Touching conductive parts when the protective conductor is interrupted can result in death or serious injury.</p> <ul style="list-style-type: none"> • Ensure that the external protective conductor satisfies at least one of the following conditions: <ul style="list-style-type: none"> – It has been laid so that it is protected against mechanical damage. ¹⁾ – For an individual conductor, it has a cross-section of at least 10 mm² Cu. – As a conductor of a multi-conductor cable, it has a cross-section of at least 2.5 mm² Cu. – It has a second protective conductor in parallel with the same cross-section. – It complies with the local regulations for equipment with increased leakage current. <p>¹⁾ Cables laid within control cabinets or closed machine housings are considered to be adequately protected against mechanical damage.</p>

 WARNING
<p>Danger of an accident due to missing warning labels in the national language.</p> <p>Missing warning labels in the national language can result in death or serious injury.</p> <ul style="list-style-type: none"> • Attach the component warning labels in the national language.

 WARNING
<p>Fire hazard due to overheating because of inadequate ventilation clearances</p> <p>Inadequate ventilation clearances can cause overheating with a risk to personnel due to smoke and fire. This can also result in more downtimes and reduced service lives of Line Modules.</p> <ul style="list-style-type: none"> • Observe the cooling clearances above, below, and in front of the Line Modules which are specified in the dimension drawings.

 CAUTION
<p>Fire hazard due to overheating when the total length of the power cables is exceeded</p> <p>Overheating and a fire can result when the total length of the power cables is exceeded.</p> <ul style="list-style-type: none"> • Ensure that the total length of the power cables (motor supply cables and DC link cables) does not exceed the values specified in the technical data.

NOTICE**Material damage caused by the failure to remove lifting lugs for devices of frame size JX**

The failure to remove lifting lugs from devices of frame size JX can cause damage to the device as a result of undershooting the necessary voltage clearances.

- For devices of frame size JX, remove the lifting lugs marked in red once the devices have been installed.

NOTICE**Material damage caused by loose power connections**

Insufficient tightening torques or vibration can result in faulty electrical connections. This can cause fire damage or functional faults.

- Tighten all power connections with the specified tightening torques, e.g. line supply connection, motor connection, DC link connections.
- Check the tightening torques of all power connections at regular intervals and tighten them when required. This applies in particular after transport.

NOTICE**Damage to the equipment when performing a voltage test as a result of connections that are not disconnected**

As part of routine tests, SINAMICS S components undergo a voltage test according to EN 61800-5-1. Connected devices can be damaged.

- Disconnect or unplug all SINAMICS devices before the voltage test of the machine equipment according to EN 60204-1, Section 18.4.

NOTICE**Damage through use of incorrect DRIVE-CLiQ cables**

Damage or malfunctions can occur on the devices or system when DRIVE-CLiQ cables are used that are either incorrect or have not been approved for this purpose.

- Only use suitable DRIVE-CLiQ cables that have been approved by Siemens for the particular application.

8.4.3 Interface description

8.4.3.1 Overview

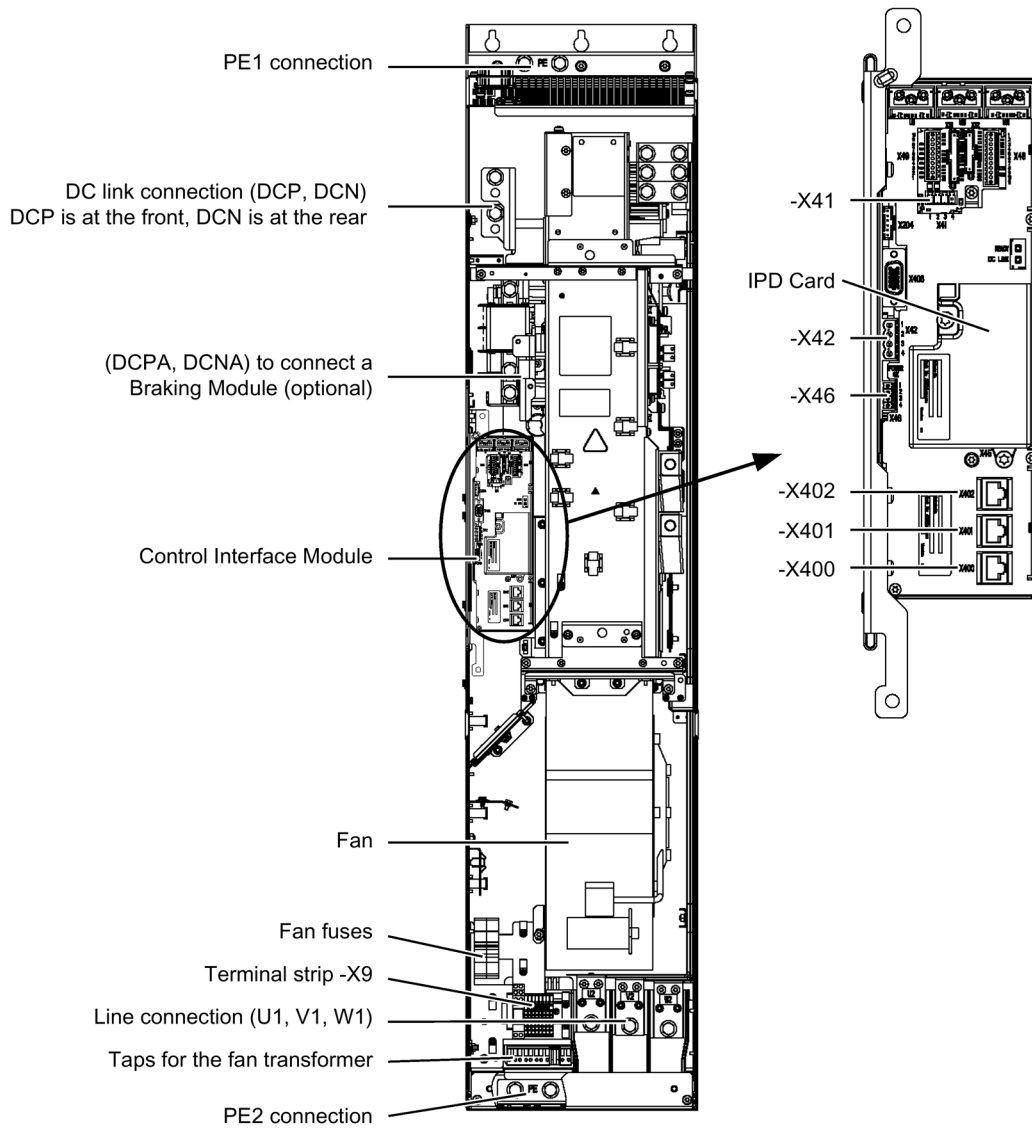

Figure 8-3 Active Line Module, frame size GX

8.4 Air-cooled Active Line Modules for the grid infeed, chassis format

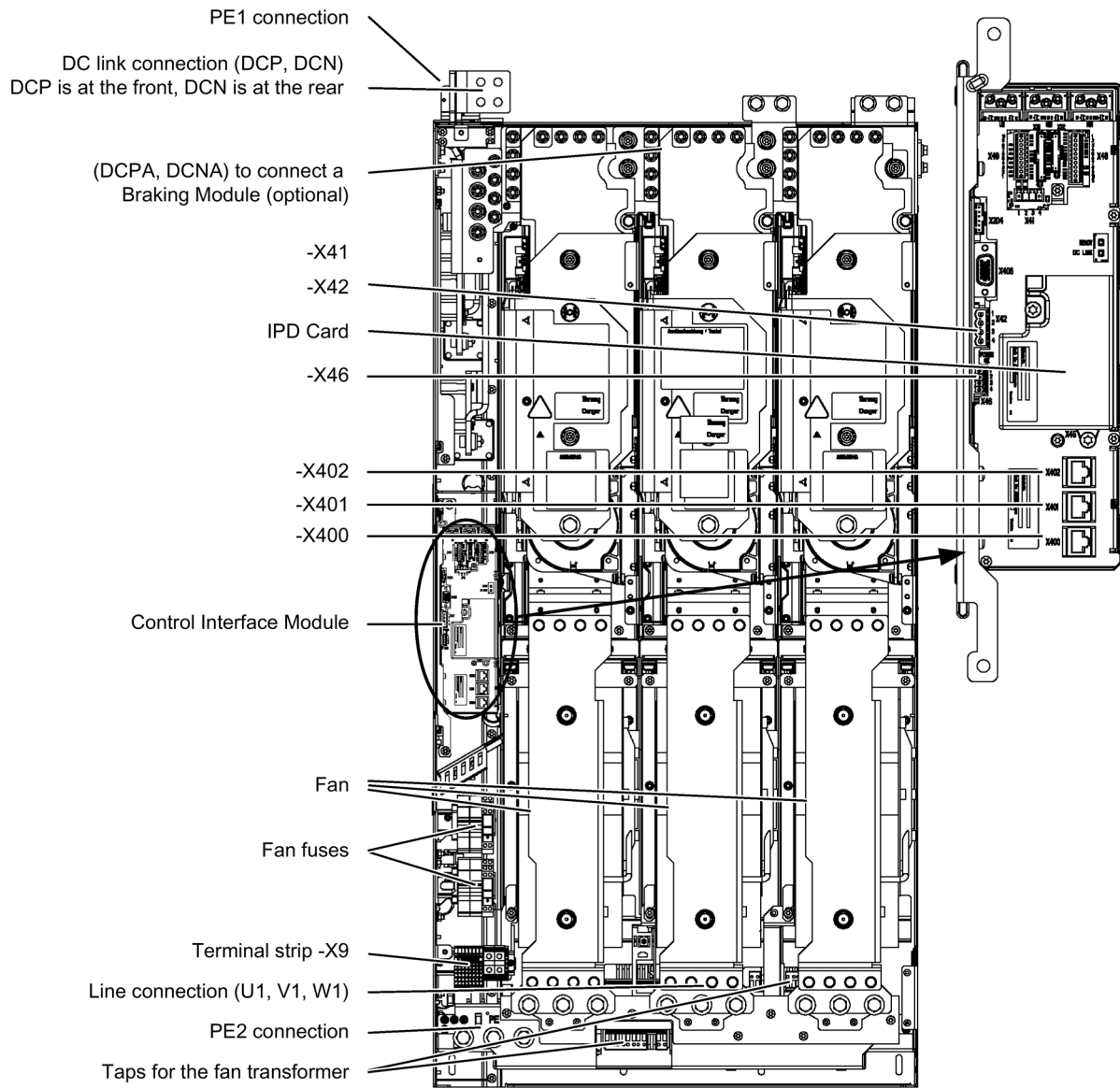

Figure 8-4 Active Line Module, frame size JX

8.4.3.2 Connection example

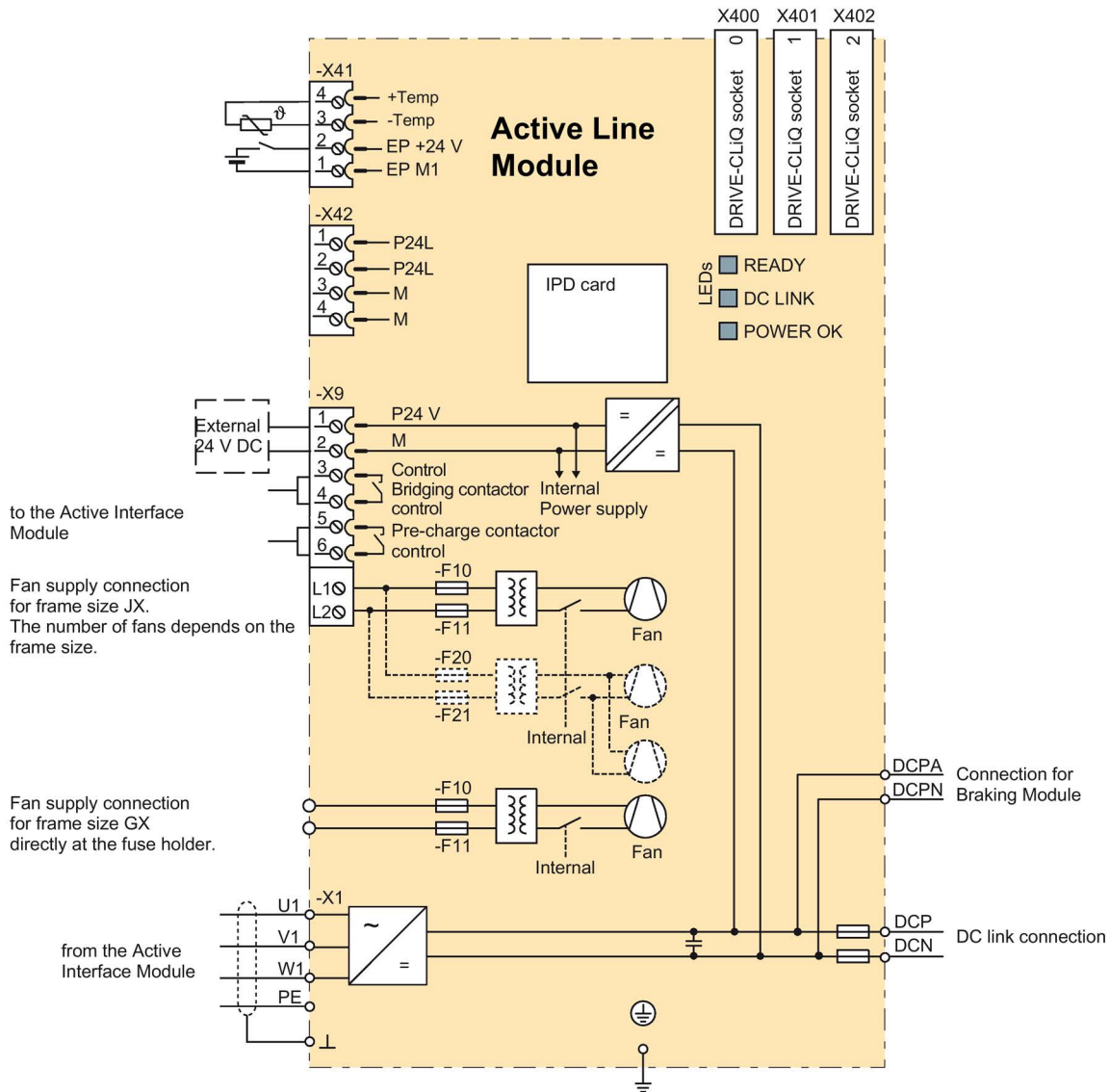

Figure 8-5 Active Line Module connection diagram

8.4.3.3 Line/load connection

Table 8- 2 Line/load connection of the Active Line Module

Terminals	Technical data
U1, V1, W1 3 AC power input	Voltage: <ul style="list-style-type: none"> • 3 AC 320 V -10 % (-15 % < 1 min) ... 3 AC 480 V +10 % • 3 AC 500 V -10 % (-15 % < 1 min) ... 3 AC 690 V +10 % Frequency: 47 ... 63 Hz Connecting thread: <ul style="list-style-type: none"> • Frame size GX: M10 / 25 Nm for cable lugs in accordance with DIN 46234 / DIN 46235 ¹⁾ • Frame size JX: M12 / 50 Nm for cable lugs in accordance with DIN 46234 / DIN 46235 ¹⁾
D CPA, DCNA Connection for Braking Module	Voltage: <ul style="list-style-type: none"> • 520 ... 750 V DC • 750 ... 1035 V DC Connections: <ul style="list-style-type: none"> • Frame size GX: Threaded bolts M6 / 6 Nm for cable lugs in accordance with DIN 46234 / DIN 46235 ¹⁾ • Frame size JX: d = 13 mm (M12/50 Nm) flat connector for busbar
D CP, DCN DC power output	Voltage: <ul style="list-style-type: none"> • 520 ... 750 V DC • 750 ... 1035 V DC Connections: <ul style="list-style-type: none"> • Frame size GX: Thread M10 / 25 Nm for cable lugs in accordance with DIN 46234 / DIN 46235 ¹⁾ • Frame size JX: d = 13 mm (M12/50 Nm) flat connector for busbar
PE connection PE1, PE2	Connecting thread: <ul style="list-style-type: none"> • Frame size GX: M10 / 25 Nm for cable lugs in accordance with DIN 46234 / DIN 46235 ¹⁾ • Frame size JX: M12 / 50 Nm for cable lugs in accordance with DIN 46234 / DIN 46235 ¹⁾

¹⁾ Dimensions for connecting alternative cable lugs, see "Cable lugs" in the Appendix.

8.4.3.4 X9 terminal strip

Table 8- 3 Terminal strip X9

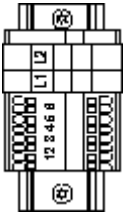
	Terminal	Signal name	Technical data
	1	P24V	Voltage: 24 V DC (20.4 ... 28.8 V) Current consumption: max. 1.7 A
	2	M	
	3	Bypass contactor control	for Active Interface Module, X609:11
	4		for Active Interface Module, X609:12
	5	Pre-charge contactor control	for Active Interface Module, X609:9
	6		for Active Interface Module, X609:10
	L1	Connection for fan supply (only for frame size JX)	380 ... 480 VAC / 500 ... 690 VAC Current consumption: See Technical data
	L2		
Max. connectable cross-section: Terminals 1 ... 6: 2.5 mm ² , Terminals L1 - L2: 35 mm ²			

Note

Connecting fan supply, with frame size GX

The fan supply for frame size GX is connected directly to fuse holder -F10 or -F11.

Note

For devices with connection voltages of 320 V ... 480 V, for operation on a main grid with voltages <380 V, direct supply from the main grid is not possible. In this case, a separate power supply for the device fan with 1 AC 400 V must be provided; the current drawn by the fan can be taken from the technical data. The taps for the fan transformer must be selected for 400 V.

8.4.3.5 X41 EP terminal / temperature sensor connection

Table 8- 4 Terminal strip X41

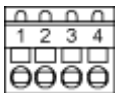
	Terminal	Function	Technical data
	1	EP M1 (Enable Pulses)	Supply voltage: 24 V DC (20.4 ... 28.8 V) Current consumption: 10 mA
	2	EP +24 V (Enable Pulses)	
	3	- Temp	Temperature sensor connection KTY84-1C130/PTC
	4	+ Temp	
Max. connectable cross-section 1.5 mm ²			

! WARNING
Risk of death from electric shock in the event of voltage flashovers at the temperature sensor

Voltage flashovers in the signal electronics can occur in motors without safe electrical separation of the temperature sensors.

- Only use temperature sensors that fully comply with the specifications of the electrical separation.
- If safe electrical separation cannot be guaranteed (for linear motors or third-party motors, for example), use a Sensor Module External (SME120 or SME125) or a Terminal Module TM120.

NOTICE
Device failure due to unshielded or incorrectly routed cables to temperature sensors

Unshielded or incorrectly routed cables to temperature sensors can result in interference being coupled into the signal processing electronics from the power side. This can significantly disturb all signals (fault messages) up to failure of individual components (destruction of the devices).

- Only use shielded cables as temperature sensor cables.
- If temperature sensor cables are routed together with the motor cable, use twisted-pair, separately-shielded cables.
- Connect the cable shield at both ends to ground potential over a large surface area.
- Recommendation: Use suitable Motion Connect cables.

NOTICE
Risk of motor overheating due to incorrectly connected KTY temperature sensor

A KTY temperature sensor connected with incorrect polarity cannot detect if the motor overheats.

- Make sure that you connect the KTY temperature sensor with the correct polarity.

Note

The temperature sensor connection can be used for motors that are equipped with a KTY84-1C130 or PTC probe in the stator windings.

Note
Connection to terminals 1 and 2

For operation, 24 V DC must be connected to terminal 2 and ground to terminal 1. Pulse suppression is activated when terminals are disconnected.

8.4.3.6 X42 terminal strip

Table 8- 5 Terminal strip X42 voltage supply for Control Unit, Sensor Module and Terminal Module

	Terminal	Function	Technical data
	1	P24L	Voltage supply for Control Unit, Sensor Module, and Terminal Module (18 to 28.8 V) Maximum load current: 3 A
	2		
	3	M	
	4		
Max. connectable cross-section 2.5 mm ²			

Note

Connection options for terminal strip X42

The terminal strip is not intended to freely provide a 24 V DC supply (for example for supplying additional components on the plant or system side), as the voltage supply of the Control Interface Module could also be overloaded and the correct functioning could thus be compromised.

8.4.3.7 DRIVE-CLiQ interfaces X400, X401, X402

Table 8- 6 DRIVE-CLiQ interfaces X400, X401, X402

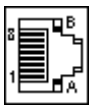
	PIN	Signal name	Technical data
	1	TXP	Transmit data +
	2	TXN	Transmit data -
	3	RXP	Receive data +
	4	Reserved, do not use	
	5	Reserved, do not use	
	6	RXN	Receive data -
	7	Reserved, do not use	
	8	Reserved, do not use	
	A	+ (24 V)	24 V power supply
	B	M (0 V)	Electronics ground
Blanking plate for DRIVE-CLiQ interfaces (50 pcs.) Article number: 6SL3066-4CA00-0AA0			

8.4.3.8 Significance of the LEDs on the Control Interface Module in the Active Line Module

Table 8- 7 Significance of the LEDs "READY" and "DC LINK" on the Control Interface Module in the Active Line Module

LED state		Description
READY	DC LINK	
Off	Off	The electronics power supply is missing or out of tolerance.
Green	Off	The component is ready for operation and cyclic DRIVE-CLiQ communication is taking place.
	Orange	The component is ready for operation and cyclic DRIVE-CLiQ communication is taking place. The DC link voltage is present.
	Red	The component is ready for operation and cyclic DRIVE-CLiQ communication is taking place. The DC link voltage is too high.
Orange	Orange	DRIVE-CLiQ communication is being established.
Red	---	At least one fault is present in this component. Note: The LED is activated irrespective of any reconfiguring of the corresponding messages.
Flashing 0.5 Hz: Green / red	---	Firmware is being downloaded.
2 Hz flashing: Green / red	---	Firmware download is complete. Waiting for POWER ON.
2 Hz flashing: Green / Orange or Red / Orange	---	Component detection using LED is activated (p0124) Note: The two options depend on the LED status when component detection is activated via p0124 = 1.

Table 8- 8 Meaning of the LED "POWER OK" on the Control Interface Module in the Active Line Module

LED	Color	Status	Description
POWER OK	Green	Off	DC link voltage < 100 V and voltage at -X9:1/2 less than 12 V.
		On	The component is ready for operation.
		Flashing light	There is a fault. If the LED continues to flash after you have performed a POWER ON, please contact your Siemens service center.



WARNING

Risk of death when live parts of the DC link are touched

Irrespective of the state of the LED "DC LINK", hazardous DC link voltages can always be present.

- Observe the warning information on the component.

8.4.4 Dimension drawing

Dimension drawing, frame size GX

The minimum clearances for cooling are indicated by the dotted line.

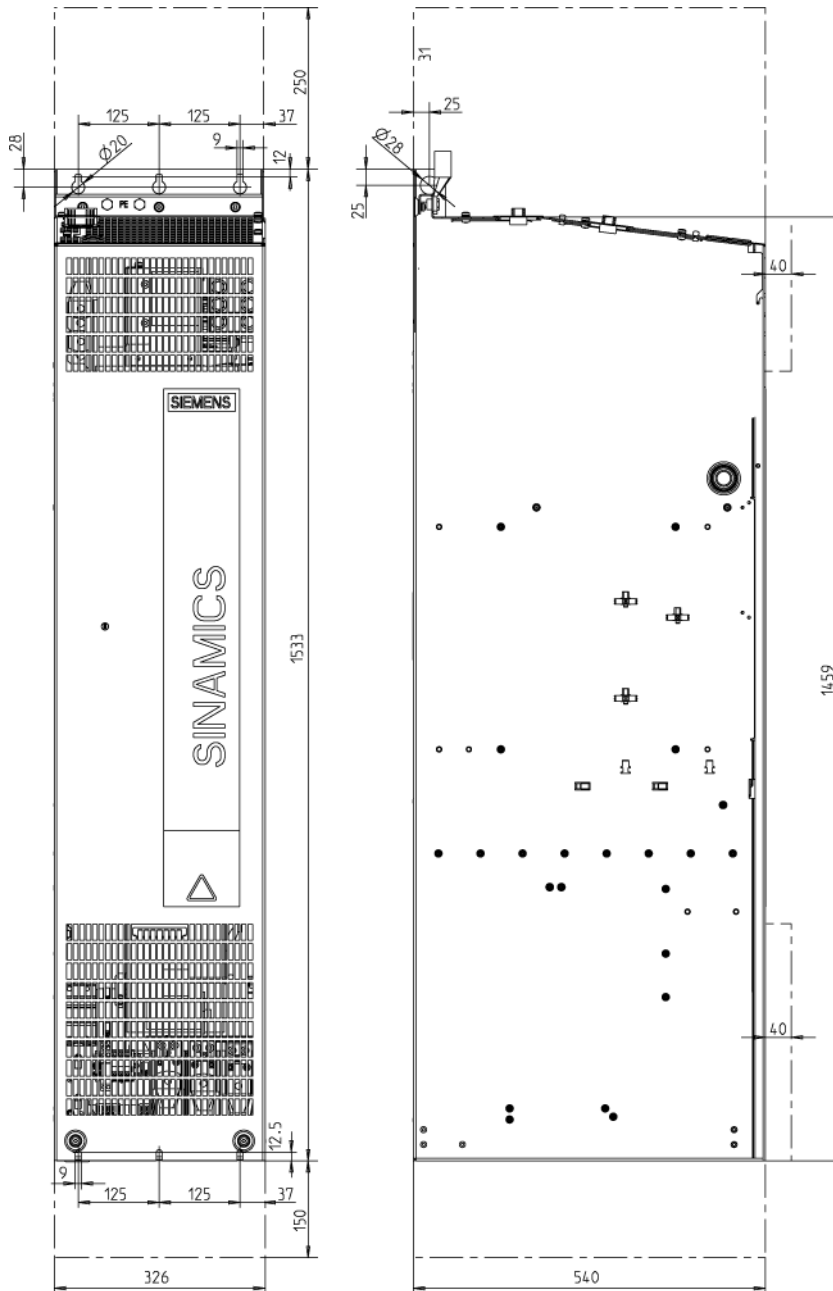

Figure 8-6 Dimension drawing Active Line Module, frame size GX Front view, side view

8.4.5 Electrical connection

Adjusting the fan voltage (-T10)

The power supply for the device fans (1 AC 230 V) in the Active Line Module (-T10) is taken from the line supply using transformers. The locations of the transformers are indicated in the interface descriptions.

For devices with 3 AC 380 ... 480 V rated voltage, for a supply voltage below 380 V a separate infeed in the specified voltage range for the device fan is required.

The transformers are fitted with primary taps so that they can be fine-tuned to the line supply voltage.

If necessary, the connection fitted in the factory, shown with a dashed line, must be reconnected to the actual line voltage.

Note

Two transformers (-T10 and -T20) are installed in Active Line Modules, frame size JX. The two primary-side terminals on each of these devices must be adjusted together.

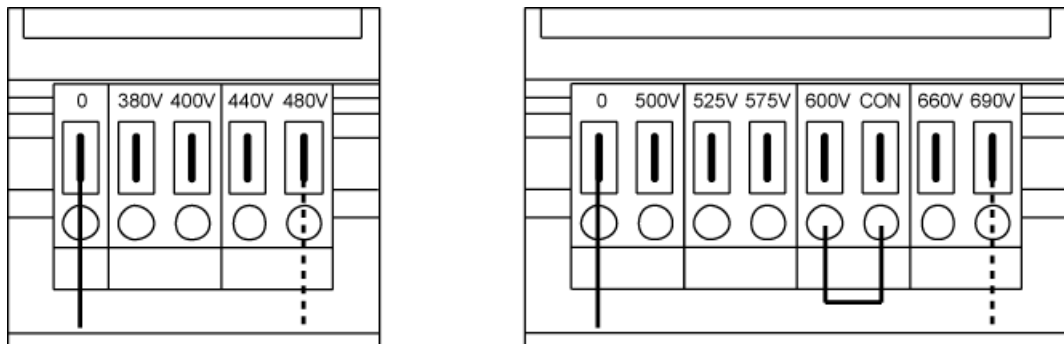

Figure 8-8 Setting terminals for the fan transformers (3 AC 380 to 480 V / 3 AC 500 to 690 V)

The supply voltage assignments for making the appropriate setting on the fan transformer are indicated in the following tables (factory presetting: 480 V/0 V or 690 V/0 V).

Note

With the 3 AC 500 V to 690 V fan transformer, a jumper is inserted between the "600 V" terminal and "CON" terminal. The "600V" and "CON" terminals are reserved for internal use.

 WARNING
Risk of fire due to overheating when the device fan voltage is insufficient
If the terminals are not reconnected to the actual line voltage, this can lead to overheating with a risk of personal injury due to smoke and fire. This can also cause the fan fuses to blow due to overload.
<ul style="list-style-type: none"> • Set the terminals in accordance with the actual line voltage.

Table 8- 9 Line voltage assignment for the setting at the fan transformer (320 ... 480 V 3 AC)

Grid voltage	Tap at the fan transformer (-T10)
< 380 V	Separate power supply required
380 V ± 10%	380 V
400 V ± 10%	400 V
440 V ± 10%	440 V
480 V ± 10%	480 V

Note

For devices with connection voltages of 320 V ... 480 V, for operation on a main grid with voltages <380 V, direct supply from the main grid is not possible. In this case, a separate power supply for the device fan with 1 AC 400 V must be provided; the current drawn by the fan can be taken from the technical data. The taps for the fan transformer must be selected for 400 V.

Table 8- 10 Line voltage assignment for the setting at the fan transformer (500 ... 690 V 3 AC)

Grid voltage	Tap at the fan transformer (-T10)
500 V ± 10%	500 V
525 V ± 10%	525 V
575 V ± 10%	575 V
600 V ± 10%	600 V
660 V ± 10%	660 V
690 V ± 10%	690 V

8.4.6 Technical data

Table 8- 11 Technical data for Active Line Modules, 3 AC 320 ... 480 V with supplements for operation with 3 AC 320 V for photovoltaic applications

Article number	6SL3330-	7TE35-0AA4	7TE41-0AA4	7TE41-4AA4		
Rated power						
- At I _{n,DC} (50 Hz, 400 V)	kW	300	630	900		
- At I _{H,DC} (50 Hz, 400 V)	kW	270	545	780		
- At I _{n,DC} (50 Hz, 320 V)	kW	270	540	770		
- At I _{n,DC} (60 Hz, 460 V)	HP	500	900	1250		
- At I _{H,DC} (60 Hz, 460 V)	HP	400	800	1000		
DC input power						
- at I _{n,DC} (50 Hz, 320 V)	kW	275	550	785		
DC link current						
- Rated current I _{n,DC}	A	549	1103	1574		
- Base load current I _{H,DC}	A	489	982	1401		
- Maximum current I _{max,DC}	A	823	1654	2361		
Infeed/regenerative feedback current						
- Rated current I _{n,E}	A	490	985	1405		
- Maximum current I _{max,E}	A	735	1477	2107		
Connection voltages		3 AC 320 ¹⁾ -10 % (-15 % < 1 min) ... 3 AC 480 +10 %				
- Line voltage	V _{ACrms}					
- Line frequency	Hz					47 ... 63
- DC voltage range, continuous	V _{DC}					520 ... 750
- Maximum DC voltage, brief ²⁾	V _{DC}					800
- Electronics power supply	V _{DC}					24 (20.4 ... 28.8)
- DC link voltage	V _{DC}	1.5 x U _{line}				
Pulse frequency	kHz	4	2,5	2,5		
Current consumption						
- Electronics current consumption (24 VDC)	A	1,35	1,5	1,7		
- Total fan current consumption (at 400 VAC)	A	1,8	5,4	5,4		
Max. ambient temperature						
- Without derating	°C	40	40	40		
- With derating	°C	55	55	55		
Efficiency at cos(phi) = 1, U_{n,DC} = 600 V						
- Rated efficiency at U _{n,AC} = 3 AC 400 V, I _{n,E}	%	98	98	98		
- Maximum efficiency (including the associated line filter AIM) at U _{n,AC} = 3 AC 400 V	%	98,3	98,4	98,6		
- European efficiency (including the associated line filter AIM) at U _{n,AC} = 3 AC 400 V	%	97,2	97,1	97,8		
Power loss ³⁾						
- Max. power loss	kW	5,1	10,1	13,3		
- Standby operation	W	36,5	40	45		
- Own use, auxiliaries in operation	W	990	3280	3280		
Harmonics line current (T_{HDI})	%	5	5	5		
Line system type		TN, IT	TN, IT	TN, IT		
DC link capacitance	µF	9600	18900	28800		
Cooling air requirement	m ³ /s	0,36	1,08	1,08		

8.4 Air-cooled Active Line Modules for the grid infeed, chassis format

Article number	6SL3330-	7TE35-0AA4	7TE41-0AA4	7TE41-4AA4	
Sound pressure level ⁴⁾ L _{pA} (1 m) at 50/60 Hz	dB(A)	69 / 73	71 / 73	71 / 73	
Line/load connection		Flat connector for screw			
		M10	M12	M12	
Max. connection cross-sections - Line connection (U1, V1, W1) - DC-link connection (DCP, DCN) - PE connection PE1 - PE connection PE2	mm ² mm ² mm ² mm ²	2 x 240 2 x 240 2 x 240 2 x 240	6 x 240 busbar 1 x 240 3 x 240	6 x 240 busbar 1 x 240 3 x 240	
Max. cable length (total of all motor cables and DC link) - Shielded - Unshielded	m m	2700 4050	3900 5850	3900 5850	
Degree of protection		IP20	IP00	IP00	
Dimensions - Width - Height - Depth	mm mm mm	326 1533 545	704 1480 550	704 1480 550	
Frame size		GX	JX	JX	
Weight	kg	136	450	450	
Recommended fuse ⁵⁾ - Number per phase (connected in parallel) - Rated current - Frame size acc. to IEC 60269		3NE1436-2 1 630 3	3NE1436-2 2 630 3	3NE1448-2 2 850 3	
Minimum short-circuit current ⁶⁾	A	8000	16000	21000	

- 1) UL approval is only applicable for the restricted voltage range 380V -10% (-15 % < 1 min)3 AC 480 +10 %, which, for this reason, is specified together with the UL approval on the type plate.
- 2) The continuous permissible DC link voltage is 750 V. Briefly up to 800 V is possible (is permissible a maximum of 5 times per hour for 1 minute).
- 3) The specified power loss is the maximum value for a 100% utilization level. The value in normal operation is lower.
- 4) Total sound pressure level of Active Interface Module and Active Line Module.
- 5) To achieve a UL-approved system, it is absolutely essential to use the fuse types specified in the table.
- 6) Minimum current required for reliable triggering of the protective devices.

8.4 Air-cooled Active Line Modules for the grid infeed, chassis format

Table 8- 12 Technical data for Active Line Modules, 3 AC 500 V ... 690 V

Article number	6SL3330-	7TG41-0AA4	7TG41-3AA4		
Rated power - For I _{n,DC} (50 Hz, 690 V) - For I _{H,DC} (50 Hz, 690 V) - For I _{n,DC} (50 Hz, 500 V) - For I _{H,DC} (50 Hz, 500 V) - For I _{n,DC} (60 Hz, 575 V) - For I _{H,DC} (60 Hz, 575 V)	kW kW kW kW HP HP	1100 980 780 710 1250 1000	1400 1215 965 880 1500 1250		
DC link current - Rated current I _{n,DC} - Base load current I _{H,DC} - Maximum current I _{max,DC}	A A A	1148 1022 1722	1422 1266 2133		
Infeed/regenerative feedback current - Rated current I _{n,E} - Maximum current I _{max,E}	A A	1025 1537	1270 1905		
Supply voltages - Line voltage - Line frequency - Electronics power supply - DC-link voltage	V _{ACrms} Hz V _{DC} V _{DC}	3 AC 500 -10 % (-15 % < 1 min) ... 3 AC 690 +10 % 47 ... 63 24 (20.4 ... 28.8) 1.5 x U _{line}			
Pulse frequency	kHz	2,5	2,5		
Current consumption - Electronics current consumption (24 VDC) - 500 VAC - 690 VAC	A A A	1,7 4,4 3,1	1,7 4,4 3,1		
Max. ambient temperature - Without derating - With derating	°C °C	40 55	40 55		
Efficiency at cos(phi) = 1, U _{n,DC} = 1035 V, U _{n,AC} = 3 AC 690 V, I _{n,E}	%	98	98		
Line system type		TN, IT	TN, IT		
DC link capacitance	µF	14400	19200		
Power loss ¹⁾ - At 50 Hz 690 V - At 60 Hz 575 V	kW kW	13,6 12,9	16,5 15,3		
Cooling air requirement	m ³ /s	1,08	1,08		
Sound pressure level ²⁾ L _{pA} (1 m) at 50/60 Hz	dB(A)	71 / 73	71 / 73		
Line/load connection		Flat connector for screw			
		M12	M12		
Max. connection cross-sections - Line connection (U1, V1, W1) - DC-link connection (DCP, DCN) - PE connection PE1 - PE connection PE2	mm ² mm ² mm ² mm ²	6 x 240 busbar 1 x 240 3 x 240	6 x 240 busbar 1 x 240 3 x 240		

8.4 Air-cooled Active Line Modules for the grid infeed, chassis format

Article number	6SL3330-	7TG41- 0AA4	7TG41- 3AA4		
Max. cable length (total of all motor cables and DC link) - Shielded - Unshielded	m m	2250 3375	2250 3375		
Degree of protection		IP00	IP00		
Dimensions - Width - Height - Depth	mm mm mm	704 1480 550	704 1480 550		
Frame size		JX	JX		
Weight	kg	450	450		
Recommended fuse ³⁾ - Number per phase (connected in parallel) - Rated current - Frame size acc. to IEC 60269		3NE1436-2 2 630 3	3NE1438-2 2 800 3		
Minimum short-circuit current ⁴⁾	A	16000	20000		

- 1) The specified power loss is the maximum value for a 100% utilization level. The value in normal operation is lower.
- 2) Total sound pressure level of Active Interface Module and Active Line Module.
- 3) To achieve a UL-approved system, it is absolutely essential to use the fuse types specified in the table.
- 4) Minimum current required for reliable triggering of the protective devices.

Overload capability

The Active Line Modules have an overload reserve.

The criterion for overload is that the drive is operated with its base load current before and after the overload occurs (a load duration of 300 s is used as a basis here).

High overload

The base load current for a high overload I_{H_DC} is based on a duty cycle of 150 % for 60 s; the max. current I_{max_DC} can flow for 5 s.

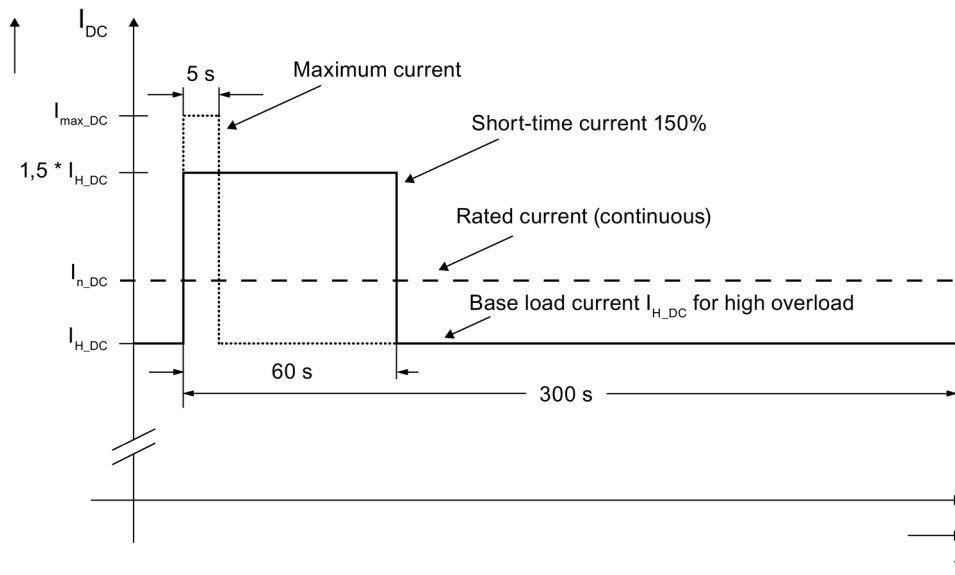

Figure 8-9 High overload

8.4.6.1 Permissible range for the step-up factor

The step-up factor (HSF) is the quotient of the DC link voltage U_{DC} and the rms value of the grid connection voltage: $HSF = U_{DC} / U_{AC,rms}$.

As a result of the permissible range for the step-up factor, for some devices it is not possible to simultaneously use the maximum AC connection voltage range and the maximum DC voltage range. When utilizing the maximum AC connection voltage range, either the maximum DC voltage range should be restricted, or when utilizing the maximum DC voltage range, the maximum AC voltage range should be restricted corresponding to the permissible range for the step-up factor. The presetting for the setpoint of the DC link voltage (p3510) corresponds to a step-up factor (HSF) of 1.5; the restrictions as listed in the following table apply. The maximum step-up factor (p3508) must be appropriately adapted.

Table 8- 13 Step-up factors

Active Line Module	Active Interface Module	Line connection voltage	Rated current	Permissible step-up factor range	Maximum step-up factor (p3508)
6SL3330-7TE35-0AA4	6SL3300-7TE35-0AA0	320 ... 480 V	490 A	1,42 ... 3,0	3,0
6SL3330-7TE41-0AA4	6SL3300-7TE41-4AA0	320 ... 480 V	985 A	1,42 ... 2,3	2,3
6SL3330-7TE41-4AA4	6SL3300-7TE41-4AA0	320 ... 480 V	1405 A	1,42 ... 2,3	2,3
6SL3330-7TG41-0AA4	6SL3300-7TG41-3AA0	500 ... 690 V	1025 A	1,42 ... 2,0	2,0
6SL3330-7TG41-3AA4	6SL3300-7TG41-3AA0	500 ... 690 V	1270 A	1,42 ... 2,0	2,0

8.4.6.2 Derating factors

When using the Active Line Module, the power must be derated depending on the ambient temperature, installation altitude and the $\cos\phi$.

Also refer to the Low Voltage Engineering Manual: LV Engineering Manual (<http://support.automation.siemens.com/WW/view/en/83180185>)

An application description is available to determine the available reactive power: Application description reactive power compensation (<http://support.automation.siemens.com/WW/view/en/105643094>)

8.5 Active Interface Modules, liquid-cooled

8.5.1 Chassis format

Liquid-cooled Active Interface Modules are used in conjunction with liquid-cooled Active Line Modules in chassis format. The liquid-cooled Active Interface Modules contain a Clean Power Filter with basic RI suppression, the pre-charging circuit for the Active Line Module, the line voltage sensing circuit and monitoring sensors.

The bypass contactor must be provided separately for frame size JIL.

The vast majority of line harmonics are suppressed by the Clean Power Filter.

The liquid-cooled Active Interface Module contains:

- Clean Power Filter
- Filter reactor
- Pre-charging circuit
- Grid voltage sensing module VSM10

The liquid-cooled Active Interface Modules comprise the following components:

- Filter reactor
- Filter module
- Associated connection elements (pressure hose, cable, hose connections)

You can find descriptions for the liquid-cooled Active Interface Modules in the Chassis power units manual liquid cooled (<http://support.automation.siemens.com/WW/view/en/92544333>).

Note

The general data in the SINAMICS Low Voltage Engineering Manual should be carefully observed.

Especially for island grids and weak grids, a grid analysis should be performed with the following content:

- Analysis of the complete drive system, including diesel engines, with statements regarding the total harmonic distortion factor (T_{HD}) – along with the aptitudes of the individual harmonics as a function of the customer's grid parameters. The necessary operating modes must be taken into account.

As a result of this analysis, it may be necessary to make adaptations to the drive system, especially the Active Interface Module.

These adaptations cannot be carried out by the region/customer, but by the manufacturer's factory. Further, these adaptations are not part of the analysis.

The application support group in head office sales can provide support when simulating and performing the grid analysis.

8.6 Liquid-cooled Active Line Modules for the grid infeed, chassis format

8.6.1 Description

The self-commutating infeed / regenerative feedback units act as step-up converters and generate a stabilized DC link voltage that is 1.5x greater (factory setting) than the rated line supply voltage. In this way, the connected Motor Modules are isolated from the line voltage. This improves the dynamic response and control quality because line tolerances and fluctuations do not affect the motor voltage.

If required, the Active Line Modules can also provide reactive power compensation.

Table 8- 14 Active Line Modules for grid infeed

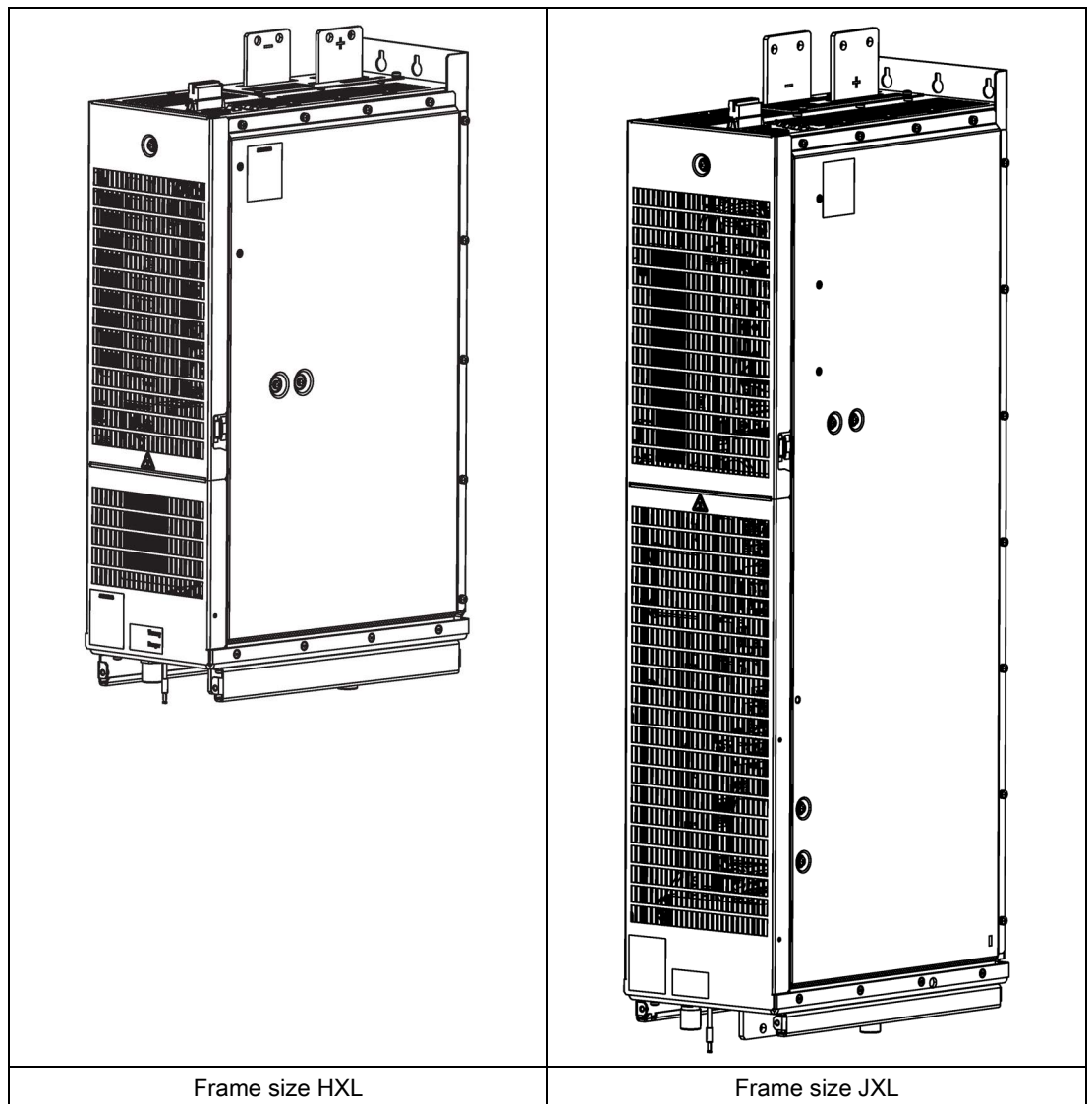

Active Infeed components

An Active Infeed comprises an Active Interface Module and an Active Line Module.

In the case of an Active Infeed with an Active Line Module of frame sizes HXL or JXL, the bypass contactor is not included in the associated Active Interface Module, but must be provided separately. The Active Interface Modules and Active Line Modules of this frame size have degree of protection IP00.

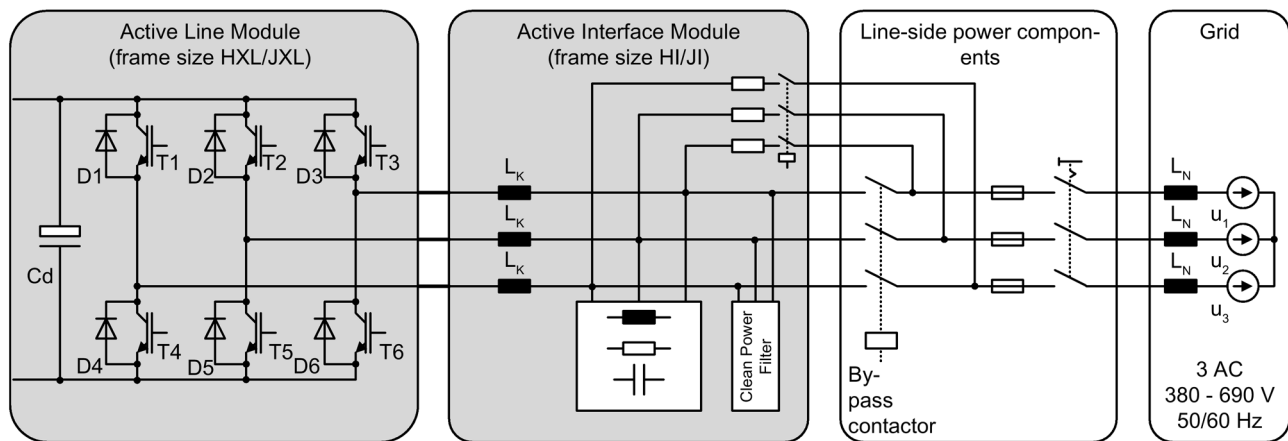

Figure 8-10 Overview of Active Infeeds, frame sizes HI/HXL and JI/JXL

Parallel connection of Active Line Modules to increase power rating

Up to four Active Line Modules with the same power rating can be connected in parallel in order to increase power.

The following rules must be observed when connecting Active Line Modules in parallel:

- Up to 4 identical Active Line Modules can be connected in parallel.
- A common Control Unit is required whenever the modules are connected in parallel.
- With multiple infeeds, power must be supplied to the systems from a common infeed point (i.e. different supply systems are not permitted).
- A derating factor of 5% must be taken into consideration, regardless of the number of modules connected in parallel.

Note

It is only possible to connect identical power units in parallel if all of the power units have the same hardware version.

8.6.2 Safety information

 **WARNING**

Danger to life if the fundamental safety instructions and remaining risks are not carefully observed

If the fundamental safety instructions and remaining risks in Chapter 1 are not observed, accidents involving severe injuries or death may occur.

- Adhere to the fundamental safety instructions.
- When assessing the risk, take into account residual risks.

 **DANGER**

Danger to life due to electric shock and fire hazard caused by overcurrent protective equipment tripping too late

Overcurrent protective equipment that trips too late or not all can cause electric shock or fire.

- To protect personnel and for fire protection purposes, at the infeed point, the short-circuit rating and loop impedance must match the specifications in the documentation so that the installed overcurrent protection devices trip within the specified time.

 **DANGER**

Danger to life through electric shock due to a high DC-link voltage

As long as the Line Module is connected to the line supply, the DC link is charged with a high voltage. Contact with components can result in death or serious injury.

- Isolate the Line Module from the line supply during installation and maintenance work, e.g. via the line contactor or main switch.

 **DANGER**

Danger to life through electric shock due to the residual charge of the DC-link capacitors

Because of the DC-link capacitors, a hazardous voltage is present for up to 5 minutes after the power supply has been switched off.

Contact with live parts can result in death or serious injury.

- Only open the device after 5 minutes have elapsed.
- Measure the voltage before starting work on the DCP and DCN DC-link terminals.



 WARNING
<p>Danger to life due to high leakage currents caused by an interrupted external protective conductor</p> <p>The drive components conduct a high leakage current via the protective conductor. Touching conductive parts when the protective conductor is interrupted can result in death or serious injury.</p> <ul style="list-style-type: none"> • Ensure that the external protective conductor satisfies at least one of the following conditions: <ul style="list-style-type: none"> – It has been laid so that it is protected against mechanical damage. ¹⁾ – For an individual conductor, it has a cross-section of at least 10 mm² Cu. – As a conductor of a multi-conductor cable, it has a cross-section of at least 2.5 mm² Cu. – It has a second protective conductor in parallel with the same cross-section. – It complies with the local regulations for equipment with increased leakage current. <p>¹⁾ Cables laid within control cabinets or closed machine housings are considered to be adequately protected against mechanical damage.</p>

 WARNING
<p>Danger of an accident due to missing warning labels in the national language.</p> <p>Missing warning labels in the national language can result in death or serious injury.</p> <ul style="list-style-type: none"> • Attach the component warning labels in the national language.

 WARNING
<p>Fire hazard due to overheating because of inadequate ventilation clearances</p> <p>Inadequate ventilation clearances can cause overheating with a risk to personnel due to smoke and fire. This can also result in more downtimes and reduced service lives of Line Modules.</p> <ul style="list-style-type: none"> • Observe the cooling clearances above, below, and in front of the Line Modules which are specified in the dimension drawings.

 CAUTION
<p>Fire hazard due to overheating when the total length of the power cables is exceeded</p> <p>Overheating and a fire can result when the total length of the power cables is exceeded.</p> <ul style="list-style-type: none"> • Ensure that the total length of the power cables (motor supply cables and DC-link cables) does not exceed the values specified in the technical data.

NOTICE**Material damage caused by mechanically loaded busbars and liquid coolant connections**

Mechanically loaded busbars and liquid coolant connections can cause damage on the device.

- Do not use the busbars and liquid coolant connections protruding from the device as handles or as support surfaces during transport.

NOTICE**Material damage caused by loose power connections**

Insufficient tightening torques or vibration can result in faulty electrical connections. This can cause fire damage or functional faults.

- Tighten all power connections with the specified tightening torques, e.g. line supply connection, motor connection, DC-link connections.
- Check the tightening torques of all power connections at regular intervals and tighten them when required. This applies in particular after transport.

NOTICE**Damage to the equipment when performing a voltage test as a result of connections that are not disconnected**

As part of routine tests, SINAMICS S components undergo a voltage test according to EN 61800-5-1. Connected devices can be damaged.

- Disconnect or unplug all SINAMICS devices before the voltage test of the machine equipment according to EN 60204-1, Section 18.4.

NOTICE**Damage through use of incorrect DRIVE-CLiQ cables**

Damage or malfunctions can occur on the devices or system when DRIVE-CLiQ cables are used that are either incorrect or have not been approved for this purpose.

- Only use suitable DRIVE-CLiQ cables that have been approved by Siemens for the particular application.

8.6.3 Interface description

8.6.3.1 Overview

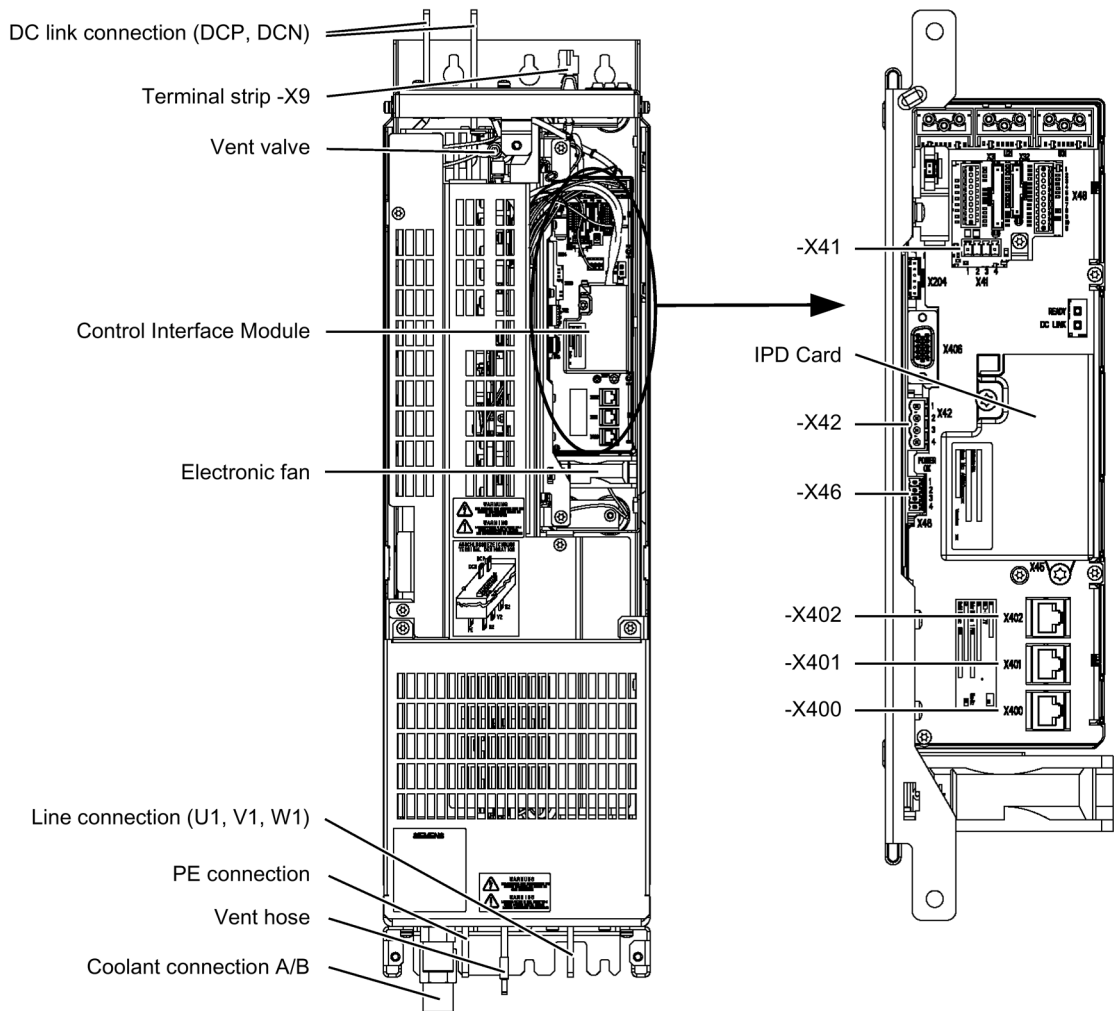

Figure 8-11 Active Line Module, frame size HXL

8.6 Liquid-cooled Active Line Modules for the grid infeed, chassis format

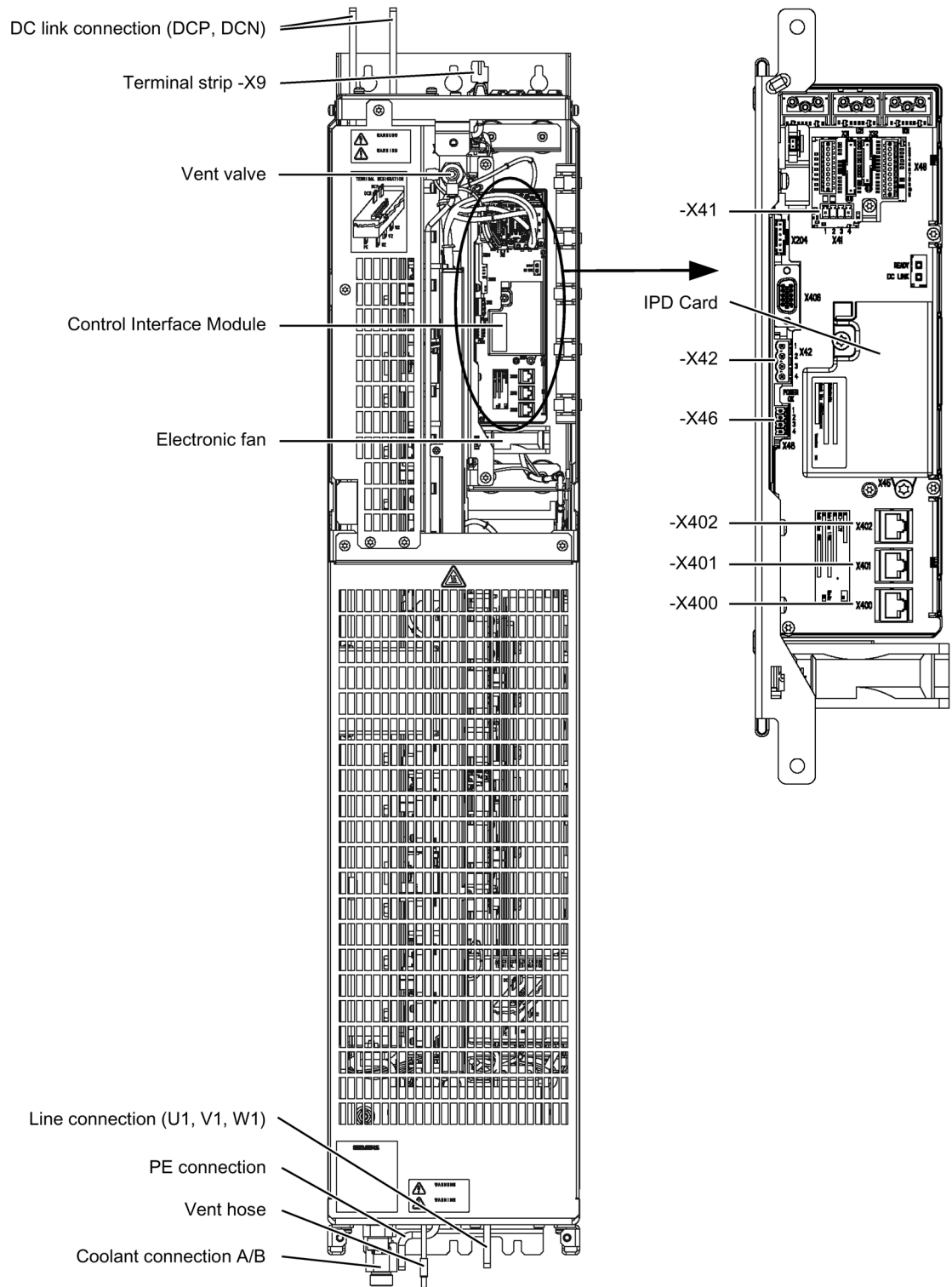

Figure 8-12 Active Line Module, frame size JXL

8.6.3.2 Connection example

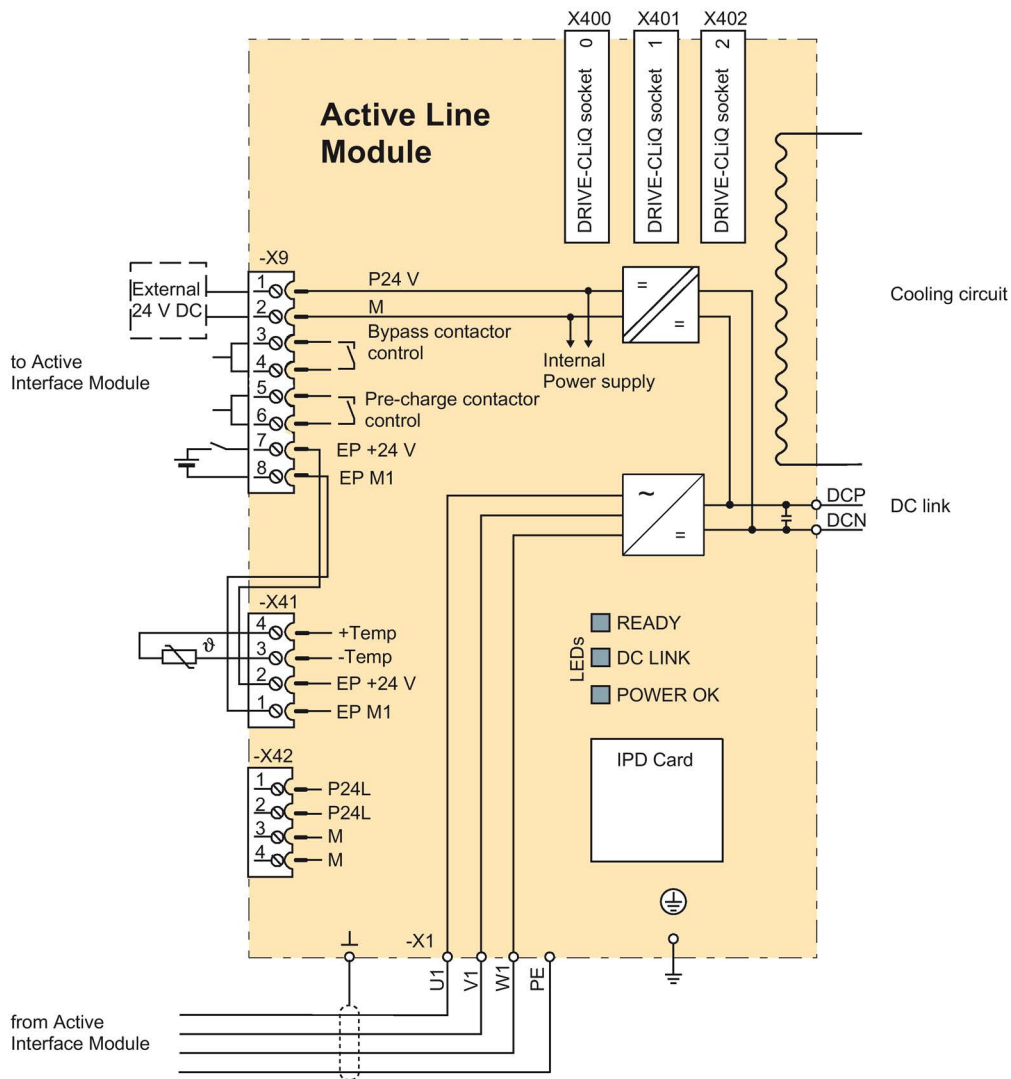

Figure 8-13 Example connection of Active Line Module

8.6.3.3 Line/load connection

Table 8- 15 Line/load connection of the Active Line Module

Terminals	Technical data
U1, V1, W1 3 AC power input	Voltage: <ul style="list-style-type: none"> 3 AC 500 V -10 % (-15 % < 1 min) ... 3 AC 690 V +10 % Frequency: 47 ... 63 Hz Connecting lugs: <ul style="list-style-type: none"> Frame size HXL: d = 13 mm (M12/50 Nm) for cable lugs in accordance with DIN 46234 / DIN 46235 ¹⁾ Frame size JXL: d = 13 mm (M12/50 Nm) for busbar connection
DCP, DCN DC power output	Voltage: <ul style="list-style-type: none"> 750 ... 1035 V DC Connecting lugs: d = 13 mm (M12/50 Nm) for busbar connection
PE connection	Connecting lugs: <ul style="list-style-type: none"> Frame size HXL: d = 13 mm (M12/50 Nm) for cable lugs in accordance with DIN 46234 / DIN 46235 ¹⁾ Frame size JXL: d = 13 mm (M12/50 Nm) for busbar connection

¹⁾ Dimensions for connecting alternative cable lugs, see "Cable lugs" in the Appendix.

8.6.3.4 X9 terminal strip

Table 8- 16 Terminal strip X9

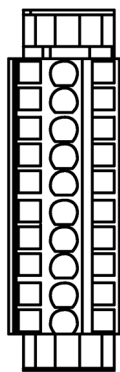
	Terminal	Signal name	Technical data
	1	P24 V	Voltage: 24 V DC (20.4 ... 28.8 V) Current consumption: See Technical data
	1	P24 V	
	2	M	
	2	M	
	3	Bypass contactor control	for Active Interface Module, -X609;11
	4		for Active Interface Module,-X609;12
	5	Pre-charge contactor control	for Active Interface Module, -X609;9
	6		for Active Interface Module, -X609;10
7	EP +24 V (Enable Pulses)	Supply voltage: 24 V DC (20.4 ... 28.8 V)	
8	EP M1 (Enable Pulses)	Current consumption: 10 mA	

Max. connectable cross-section 1.5 mm²

Note

Connection to terminals 7 and 8

For operation, 24 V DC must be connected to terminal 7 and ground to terminal 8. Pulse suppression is activated when removed.

Note

Looping through the supply voltage

The two "P24 V" or "M" terminals are jumpered in the connector. This ensures that the supply voltage is looped through, even when the connector is removed.

8.6.3.5 X41 EP terminal / temperature sensor connection

Table 8- 17 Terminal strip X41

	Terminal	Function	Technical data
	1	EP M1 (Enable Pulses)	Connected to terminal -X9:8
	2	EP +24 V (Enable Pulses)	Connected to terminal -X9:7
	3	- Temp	Temperature sensor connection KTY84-1C130/PTC
	4	+ Temp	
Max. connectable cross-section 1.5 mm ²			



! WARNING

Danger to life due to electric shock in the event of voltage flashovers at the temperature sensor

Voltage flashovers in the signal electronics can occur in motors without safe electrical separation of the temperature sensors.

- Only use temperature sensors that fully comply with the specifications of the safety isolation.
- If safe electrical separation cannot be guaranteed (for linear motors or third-party motors, for example), use a Sensor Module External (SME120 or SME125) or Terminal Module TM120.

NOTICE

Device failure as a result of unshielded or incorrectly routed cables to temperature sensors

Unshielded or incorrectly routed cables to temperature sensors can result in interference being coupled into the signal processing electronics from the power side. This can result in significant disturbance of all signals (fault messages) up to failure of individual components (destruction of the devices).

- Only use shielded cables as temperature sensor cables.
- If temperature sensor cables are routed together with the motor cable, use separately shielded cables twisted in pairs.
- Connect the cable shield to ground potential through a large surface area.
- Recommendation: Use suitable Motion Connect cables.

NOTICE**Risk of motor overheating for incorrectly connected KTY temperature sensor**

A KTY temperature sensor connected with incorrect polarity cannot detect if the motor overheats.

- Make sure that you connect the KTY temperature sensor with the correct polarity.

Note

The temperature sensor connection can be used for motors that are equipped with a KTY84-1C130 or PTC probe in the stator windings.

Note**Connection to terminal strip -X9**

A cable harness is used to connect terminals -X41:1 and -X41:2 to terminals -X9:8 and -X9:7.

8.6.3.6 X42 terminal strip

Table 8- 18 Terminal strip X42 voltage supply for Control Unit, Sensor Module and Terminal Module

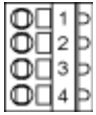
	Terminal	Function	Technical data
	1	P24L	Power supply for Control Unit, Sensor Module and Terminal Module (18 ... 28.8 V) maximum load current: 3 A
	2		
	3	M	
	4		
Max. connectable cross-section 2.5 mm ²			

Note**Connection options of terminal strip X42**

The terminal strip is not intended to supply other 24 VDC loads (for example, for supplying other components on the plant/system side), as the voltage supply of the Control Interface Module could also be overloaded and result in malfunctions.

8.6.3.7 DRIVE-CLiQ interfaces X400, X401, X402

Table 8- 19 DRIVE-CLiQ interfaces X400, X401, X402

	PIN	Signal name	Technical data
	1	TXP	Transmit data +
	2	TXN	Transmit data -
	3	RXP	Receive data +
	4	Reserved, do not use	
	5	Reserved, do not use	
	6	RXN	Receive data -
	7	Reserved, do not use	
	8	Reserved, do not use	
	A	+ (24 V)	24 V power supply
	B	M (0 V)	Electronics ground
	Blanking plate for DRIVE-CLiQ interfaces (50 pcs.) Article number: 6SL3066-4CA00-0AA0		

8.6.3.8 Cooling circuit connections

Table 8- 20 Cooling circuit connections

Connection	Technical data
Coolant connection A: Intake	Pipe thread ISO 228 - G 3/4 B (external thread 3/4", flat-sealing)
Coolant connection B: Return	
Tightening torque	60 Nm

Note

Replacement seal

The seals for the screwed connections can be used only once when the cooling circuit is first assembled. The seals must be replaced if the circuit is disassembled and assembled again.

The replacement seal is commercially available as flat 3/4" Viton seal (Viton is the commercial name for elastomers with the abbreviations FPM and FKM).

8.6.3.9 Meaning of the LEDs on the Control Interface Module in the Active Line Module

Table 8- 21 Meaning of the LEDs "READY" and "DC LINK" on the Control Interface Module in the Active Line Module

LED, state		Description
READY	DC LINK	
Off	Off	The electronics power supply is missing or out of tolerance.
Green	Off	The component is ready for operation and cyclic DRIVE-CLiQ communication is taking place.
	Orange	The component is ready for operation and cyclic DRIVE-CLiQ communication is taking place. The DC-link voltage is present.
	Red	The component is ready for operation and cyclic DRIVE-CLiQ communication is taking place. The DC-link voltage is too high.
Orange	Orange	DRIVE-CLiQ communication is being established.
Red	---	At least one fault is present in this component. Note: LED is driven irrespective of the corresponding messages being reconfigured.
Flashing light 0.5 Hz: Green red	---	Firmware is being downloaded.
2 Hz flashing: Green red	---	Firmware download is complete. Waiting for POWER ON.
2 Hz flashing: Green orange or red orange	---	Detection of the component via LED is activated (p0124) Note: The two options depend on the LED status when module recognition is activated via p0124 = 1.

Table 8- 22 Meaning of the LED "POWER OK" on the Control Interface Module in the Active Line Module

LED	Color	State	Description
POWER OK	Green	Off	DC-link voltage < 100 V and voltage at -X9:1/2 less than 12 V.
		On	The component is ready for operation.
		Flashing light	There is a fault. If the LED continues to flash after you have performed a POWER ON, please contact your Siemens service center.



WARNING

Danger of death when live parts of the DC link are touched

Irrespective of the state of the "DC LINK" LED, hazardous DC-link voltages can always be present.

- Observe the warning information on the component.

8.6.4 Dimension drawing

Dimension drawing for frame size JXL

The mandatory cooling clearances are indicated by the dotted line.

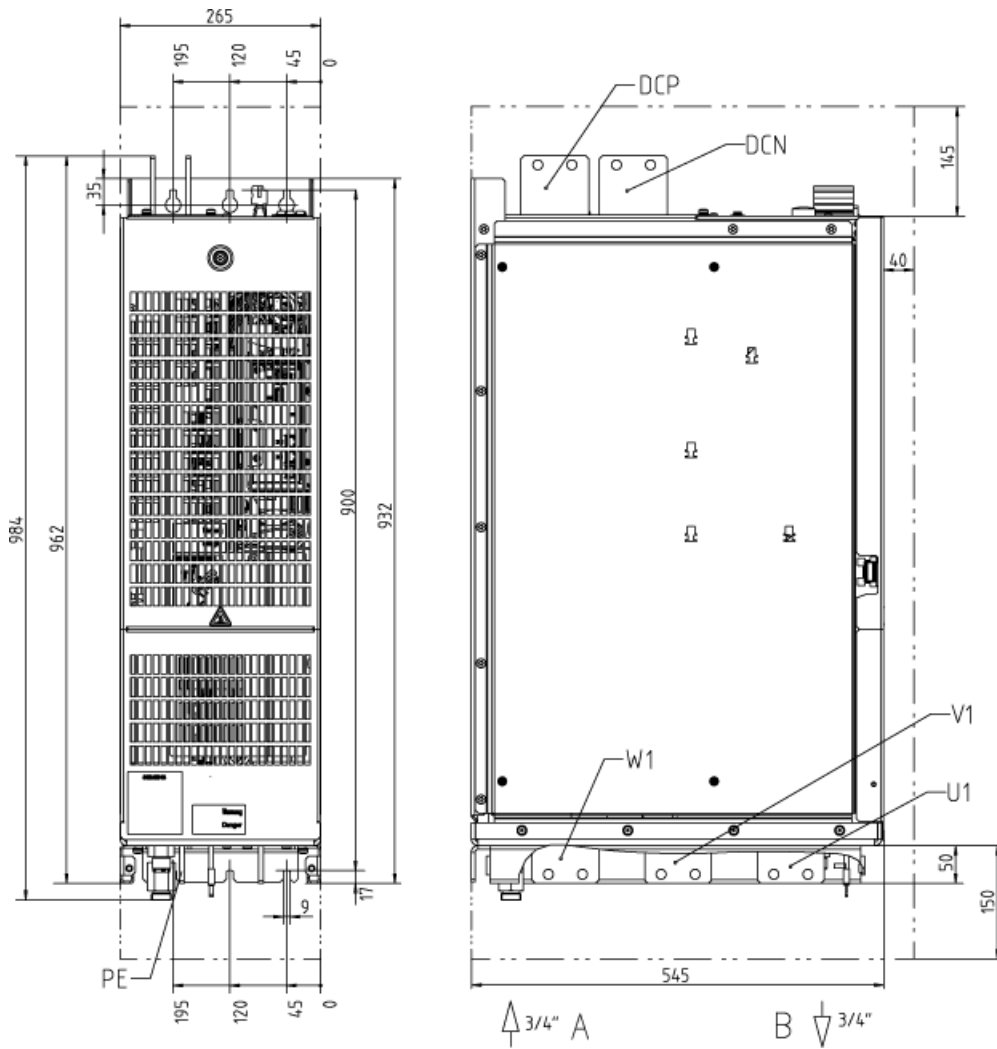

Figure 8-14 Dimension drawing Active Line Module, frame size HXL Front view, side view

8.6 Liquid-cooled Active Line Modules for the grid infeed, chassis format

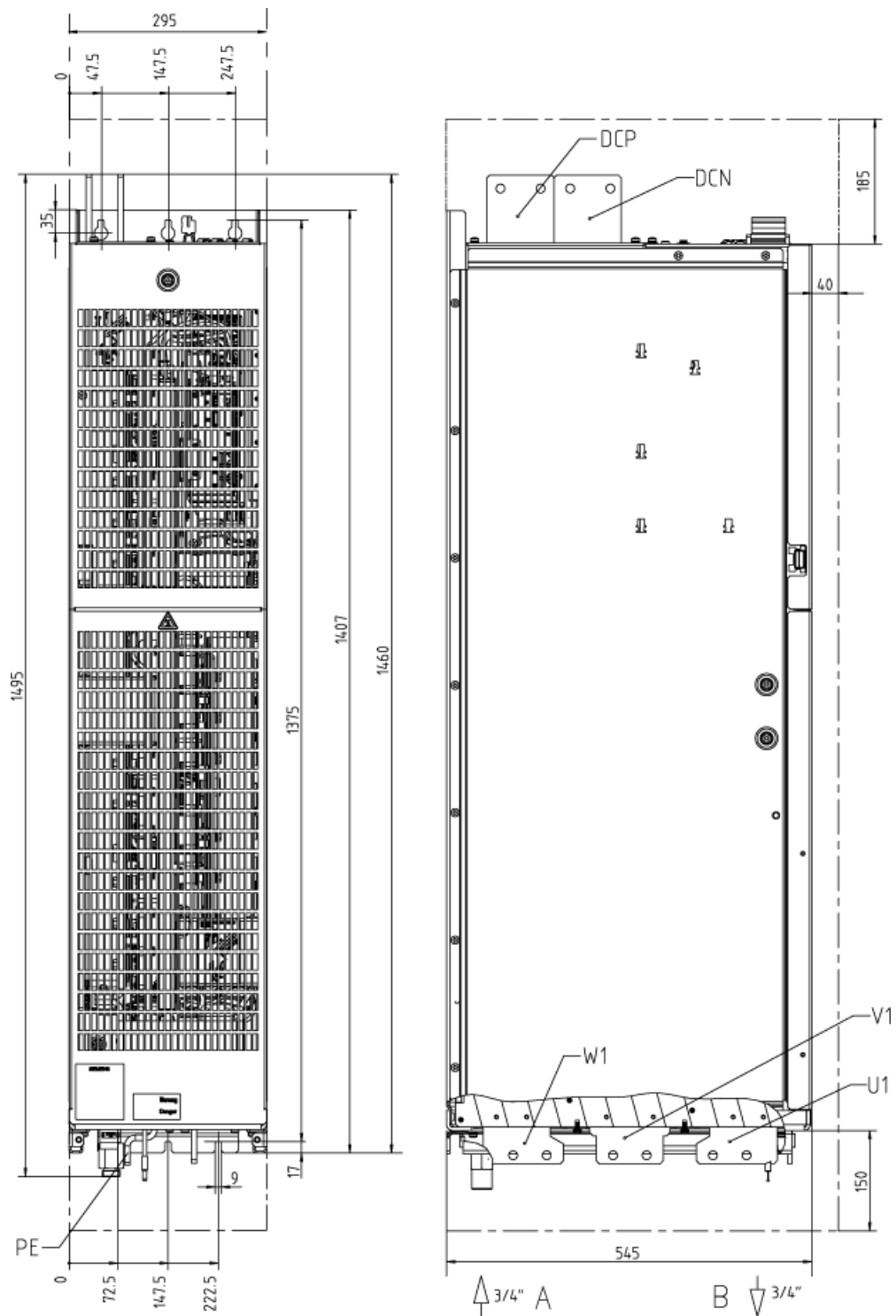

Figure 8-15 Dimension drawing Active Line Module, frame size JXL, article number 6SL3335-7TG41-3AA4. Front view, side view

8.6 Liquid-cooled Active Line Modules for the grid infeed, chassis format

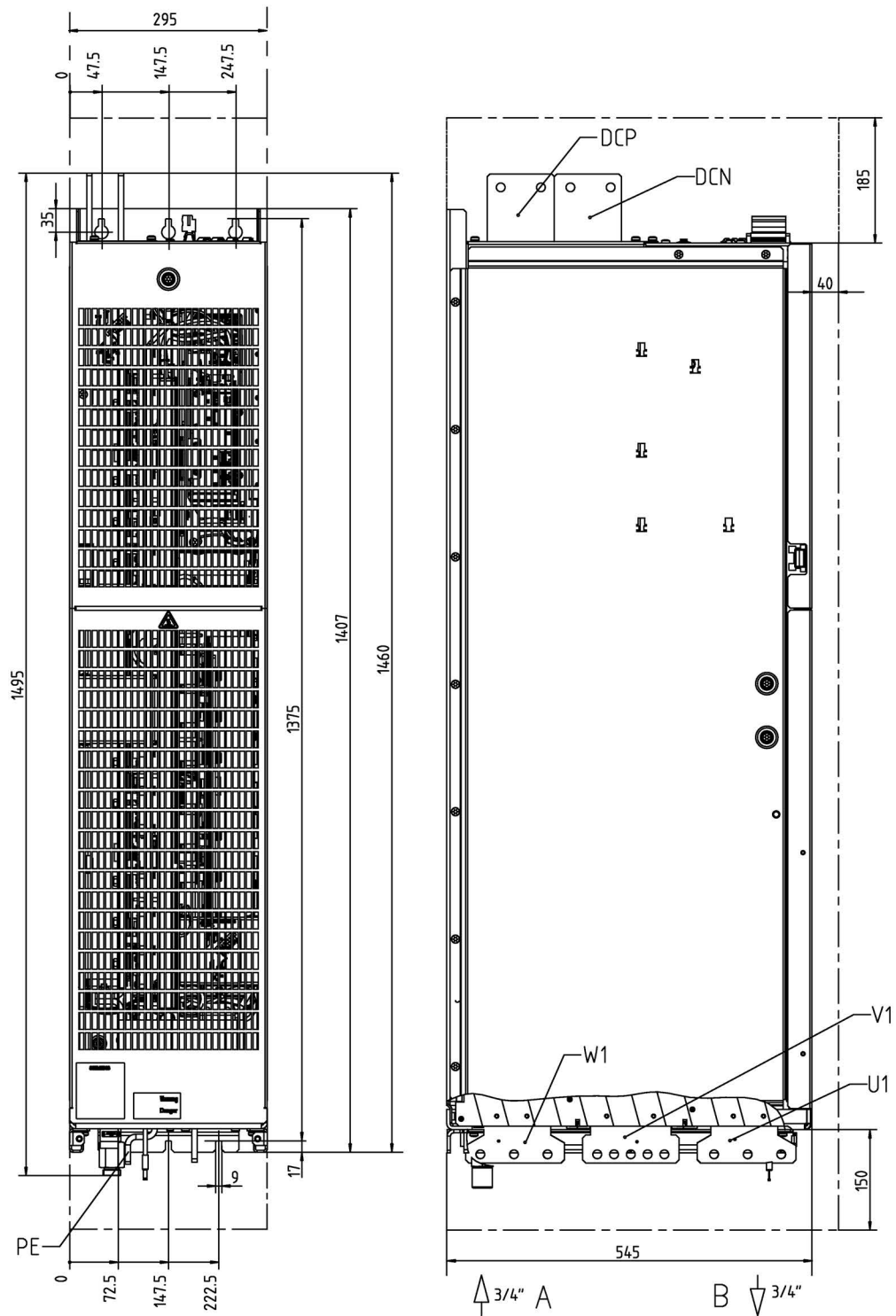

Figure 8-16 Dimension drawing Active Line Module, frame size JXL, article number 6SL3335-7TG41-6AA4. Front view, side view

8.6.5 Installation

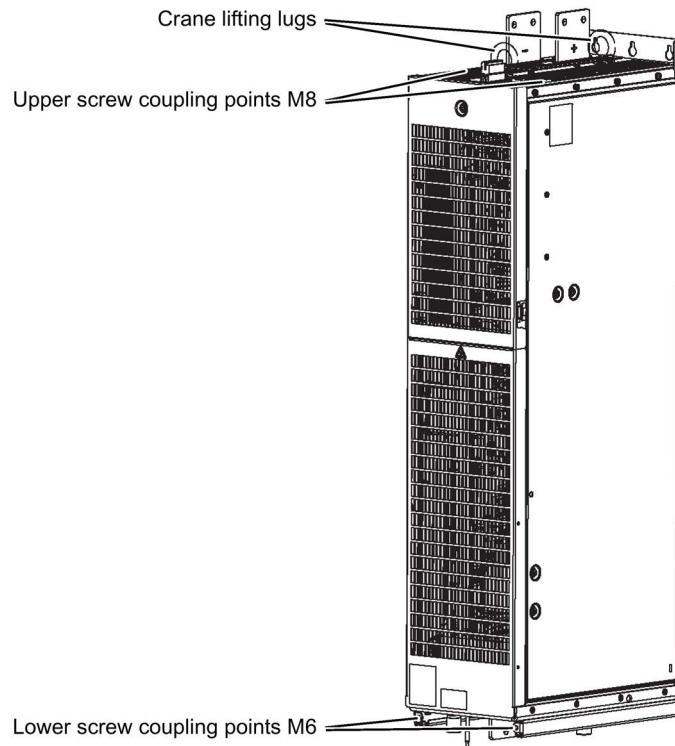

Figure 8-17 Crane lifting lugs / screw coupling points for mechanical support

Crane lifting lugs

Active Line Modules are fitted with crane lifting lugs as standard when shipped. The units can be hoisted using these lugs and transported from the pallet to the installation location.

Note

Transport in the horizontal position

Transport in the horizontal position is permissible.

It is not permissible to screw the crane lifting lug into the thread at the lower side of the Line Module.

NOTICE
Damage to the device due to improper transport
Improper transport can cause mechanical loads on the housing or busbars which can result in damage to the device.
<ul style="list-style-type: none">• Use a lifting harness with vertical ropes or chains during transport.• Do not use the busbars as handles or for fastening a lifting harness.• Only tighten the crane lifting lugs by hand. Remove the crane lifting lugs after the installation, but keep them for later use.

Screw coupling points for mechanical support

Since the Active Line Modules are housed in a very slim enclosure, they need to be mechanically supported against lateral movement and vibration if they are installed in a control cabinet. Screw coupling points are provided on the top and bottom of the units for this purpose.

If several modules are mounted adjacent to one another, they can be interconnected via the screw coupling points. When a single module is installed, lateral support can be provided by means of reinforcing plates inserted between the module and the cabinet.

Protection guard

A protection guard is mounted on the bottom of the Active Line Module ("1" in the diagram below) for use during transportation. The Active Line Module can be rested on this protection guard while it is removed from the packaging and during transportation.

Before the module is installed at its final location, this guard must be removed. To do this, remove the 4 screws ("2" in the diagram) and remove the guard.

 CAUTION
Risk of injury due to toppling when placing down on the protection guard
A module placed down on the protection guard can topple over therefore causing injury.
<ul style="list-style-type: none">• When the module is placed down on the production guard, ensure that it cannot topple over.

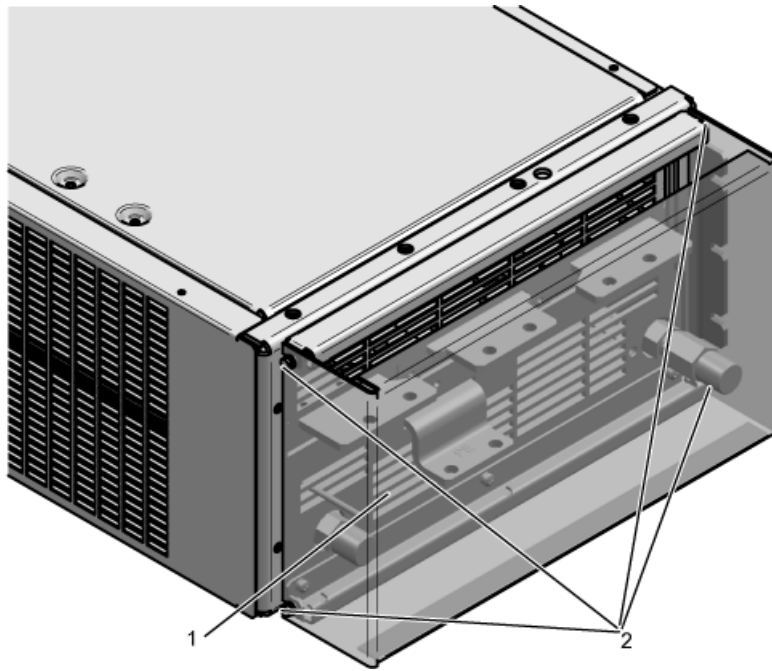

Figure 8-18 Protection guard

8.6.6 Technical specifications

Table 8- 23 Technical data for Active Line Modules, 3 AC 500 V ... 690 V

Article number	6SL3335-	7TG35-8AA4	7TG41-3AA4	7TG41-6AA4	
Rated power					
- At I _{L DC} (50Hz 690V)	kW	630	1400	1700	
- At I _{H DC} (50Hz 690V)	kW	620	1215	1490	
- At I _{L DC} (50Hz 500V)	kW	447	965	1180	
- At I _{H DC} (50Hz 500V)	kW	450	880	1080	
- At I _{L DC} (60Hz 575V)	HP	675	1500	1855	
- At I _{H DC} (60Hz 575V)	HP	506	1250	1530	
DC link current					
- Rated current I _{N DC}	A	644	1422	1740	
- Base load current I _{L DC}	A	627	1386	1700	
- Rated current I _{H DC}	A	573	1266	1550	
- Maximum current I _{max DC} ¹⁾	A	966	2133	2620	
Short time overload 1					
- Overload current	A	1146	2337	2688	
- Overload duration (time/overload cycle)	s / s	1 / 300	1 / 300	1 / 300	
- Base load current	A	575	1270	1560	
short time overload 2					
- Overload current	A	690	1524	1872	
- Overload duration (time/overload cycle)	s / s	5 / 300	5 / 300	5 / 300	
- Base load current	A	565	1250	1535	
Short time over load 3					
- Overload current	A	598	1320	1620	
- Overload duration (time/overload cycle)	s / s	30 / 300	30 / 300	30 / 300	
- Base load current	A	565	1250	1535	
Supply voltages		3 AC 500 -10% (-15% < 1 min) ... 3 AC 690 +10%			
- Line voltage	V _{ACrms}	47 ... 63Hz			
- Line frequency	Hz	24 (20.4 ... 28.8)			
- Electronics power supply	V _{DC}	1.5 x U _{line}			
- DC-link voltage	V _{DC}				
Infeed/regenerative feedback current					
- Rated current I _{N E}	A	575	1270	1560	
- Maximum current I _{max E} ²⁾	A	862	1905	2055	
Pulse frequency	kHz	2,5	2,5	2,5	
Electronics current consumption (24 V DC)	A	1,6	1,46	1,5	
Cooling method		Liquid cooling with integrated aluminum heat exchanger			
Power loss, max.³⁾					
- At 50 Hz 690 V	kW	5,61	13,55	17,96	
- At 60 Hz 575 V	kW	4,89	12,6	15,7	
- Dissipated to the ambient air	kW	0,16	0,61	0,79	
Max. coolant temperature					
- Without derating	°C	45	45	45	
- With derating	°C	50	50	50	
Rated flow rate for water at 70 kPa pressure drop ⁴⁾	l/min	16	27	27	
Liquid volume of integrated heat exchanger	dm ³	0,74	1,56	1,56	
DC link capacitance					
- Active Line Module	µF	9670	19330	21000	

8.6 Liquid-cooled Active Line Modules for the grid infeed, chassis format

Article number	6SL3335-	7TG35-8AA4	7TG41-3AA4	7TG41-6AA4	
Sound pressure level L _{pA} (1 m) at 50/60 Hz	dB(A)	54	56	56	
Line/load connection		Flat connection for M12 screw			
Max. connection cross-sections - Line connection (U1, V1, W1) - DC-link connection (DCP, DCN) - PE connection	mm ² mm ² mm ²	4 x 185 Busbar 4 x 185	Busbar Busbar Busbar	Busbar Busbar Busbar	
Max. cable length (total of all motor cables and DC link) - Shielded - Unshielded	m m	2250 3375	2250 3375	2250 3375	
Degree of protection		IP00	IP00	IP00	
Dimensions - Width - Height - Depth	mm mm mm	265 1002 545	295 1516 545	295 1516 545	
Frame size		HXL	JXL	JXL	
Weight	kg	110	220	230	
Recommended fuse - Number per phase (connected in parallel) - Rated current - Frame size acc. to IEC 60269	A	3NE1447-2 ⁵⁾ 1 670 3	3NE1438-2 ⁵⁾ 2 800 3	3NE1436-2 3 630 3	
Minimum short-circuit current ⁶⁾	A	8400	20000	24000	

- 1) Valid for a 5s duty cycle (overload duration) and a duty cycle duration of 300s based on the rated DC-link current.
- 2) Valid for a 5s duty cycle (overload duration) and a duty cycle duration of 300s based on the rated infeed/regenerative feedback current.
- 3) The specified power loss is the maximum value for a 100% utilization level. The value in normal operation is lower.
- 4) This value applies to the water coolant option; for other coolant types, see Chapter "Cooling circuit and coolant properties" in the SINAMICS S120 Power Units Chassis Liquid Cooled Manual.
- 5) To achieve a UL-approved system, it is absolutely essential to use the fuse types specified in the table.
- 6) Minimum current required for reliable triggering of the protective devices.

Overload capability

The Active Line Modules have an overload reserve.

The criterion for overload is that the drive is operated with its base load current before and after the overload occurs (a load duration of 300 s is used as a basis here).

High overload

The base load current for a high overload I_{H_DC} is based on a duty cycle of 150 % for 60 s; the max. current I_{max_DC} can flow for 5 s.

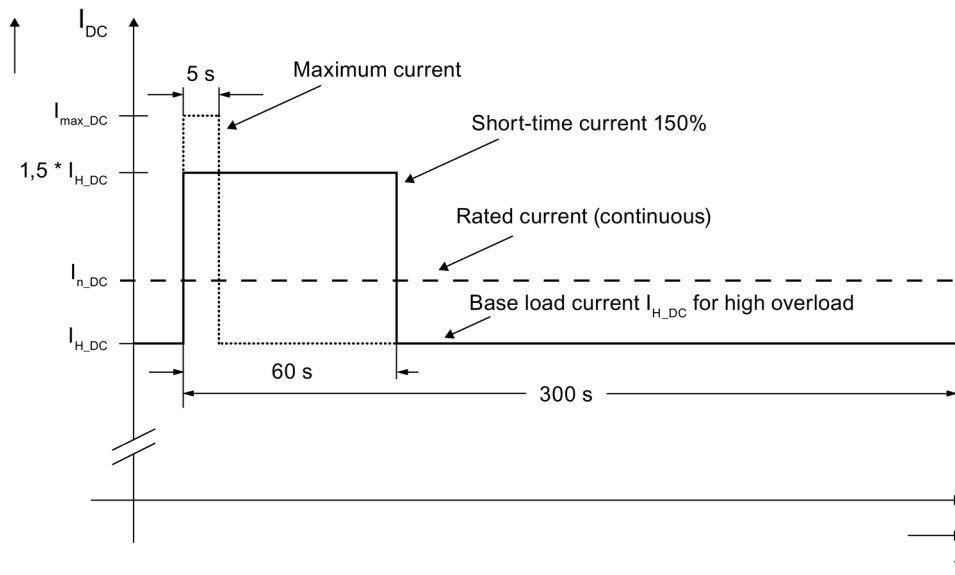

Figure 8-19 High overload

8.6.6.1 Permissible range for the step-up factor

The step-up factor (HSF) is the quotient of the DC link voltage U_{DC} and the rms value of the grid connection voltage: $HSF = U_{DC} / U_{AC,rms}$.

As a result of the permissible range for the step-up factor, for some devices it is not possible to simultaneously use the maximum AC connection voltage range and the maximum DC voltage range. When utilizing the maximum AC connection voltage range, either the maximum DC voltage range should be restricted, or when utilizing the maximum DC voltage range, the maximum AC voltage range should be restricted corresponding to the permissible range for the step-up factor. The presetting for the setpoint of the DC link voltage (p3510) corresponds to a step-up factor (HSF) of 1.5; the restrictions as listed in the following table apply. The maximum step-up factor (p3508) must be appropriately adapted.

Table 8- 24 Step-up factors

Active Line Module	Active Interface Module	Line connection voltage	Rated current	Permissible step-up factor range	Maximum step-up factor (p3508)
6SL3335-7TG35-8AA4	6SL3300-7TG35-8AA0	500 ... 690 V	575 A	1,42 ... 2,0	2,0
6SL3335-7TG41-3AA4	6SL3305-7TG41-3AA0	500 ... 690 V	1270 A	1,42 ... 2,0	2,0
6SL3335-7TG41-6AA4	6SL3305-7TG41-6AA0	500 ... 690 V	1560 A	1,42 ... 2,0	2,0

8.6.6.2 Derating factors

When using liquid-cooled Active Line Module, the power must be derated depending on the coolant temperature, the ambient temperature, installation altitude and the $\cos\phi$.

Also refer to the Low Voltage Engineering Manual: LV Engineering Manual (<http://support.automation.siemens.com/WW/view/en/83180185>)

An application description is available to determine the available reactive power: Application description reactive power compensation (<http://support.automation.siemens.com/WW/view/en/105643094>)

8.6.7 Coolant and protection against condensation

When using liquid-cooled Active Line Modules, the cooling medium specifications and the prevention of condensation must be observed.

Also refer to the Low Voltage Engineering Manual: LV Engineering Manual (<http://support.automation.siemens.com/WW/view/en/83180185>)

Function diagrams

An overview of the function charts for the grid infeed is shown in the following. They are arranged in the schematic according to the function modules described above.

The function diagrams for the corresponding firmware versions are included in the "SINAMICS S120/S150 List Manual".

Table 9- 1 Line transformer

Function diagram No.	Function diagram name
7987	Line transformer - negative sequence system controller
7988	Line transformer - island grid black start sequence control
7989	Line transformer - island grid synchronization sequence control
7990	Line transformer - transformer model
7991	Line transformer - line filter monitoring
7992	Line transformer - PLL2 (phase locked loop 2)
7993	Line transformer - transformer magnetization voltage threshold
7994	Line transformer - transformer magnetization sequence control

Table 9- 2 Grid control

Function diagram No.	Function diagram name
7982	Line control - line droop voltage correction
7983	Line control - Direct component control, harmonics control
7984	Line control - modulation depth control
7986	Line control - sequence control overcurrent

Table 9- 3 Dynamic grid support

Function diagram No.	Function diagram name
7996	Dynamic grid support - characteristic
7997	Dynamic grid support - current limitation
7998	Dynamic grid support - sequence control
7999	Dynamic grid support - line monitoring, anti-islanding

Table 9- 4 Supplementary controls

Function diagram No.	Function diagram name
8945	Reactive current/apparent current limits

Table 9- 5 Cos phi display

Function diagram No.	Function diagram name
8951	Cos phi display

Appendix

A.1 Glossary

List of the abbreviations used in the document

AISL	Anti-islanding
FRT	Fault ride through
LSS	Circuit breaker
HFRT	High frequency ride through
HVRT	High voltage ride through
LFRT	Low frequency ride through
LVRT	Low voltage ride through
MPP	Maximum power point

A.2 Cable lugs

Chassis format devices

The cable connections on the devices are designed for cable lugs according to DIN 46234 or DIN 46235.

For connection of alternative cable lugs, the maximum dimensions are listed in the table below.

These cable lugs are not to exceed these dimensions, as mechanical fastening and adherence to the voltage distances is not guaranteed otherwise.



⚠ WARNING

Danger to life as a result of electric shock when voltage clearances are fallen below when using unsuitable cable lugs

When using unsuitable cable lugs, voltage clearances can be fallen below, which in turn can result in death or severe injury.

- Only use cable lugs that do not exceed the maximum dimensions of the following table.

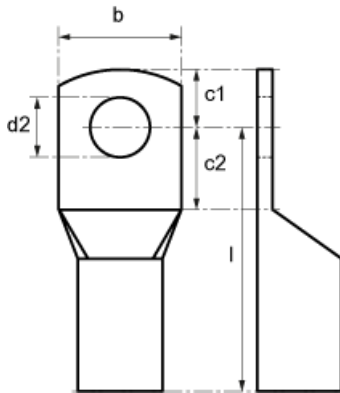

Figure A-1 Dimensions of the cable lugs

Table A- 1 Dimensions of the cable lugs

Screw / bolts	Connection cross-section [mm²]	d2 [mm]	b [mm]	l [mm]	c1 [mm]	c2 [mm]
M8	70	8,4	24	55	13	10
M10	185	10,5	37	82	15	12
M10	240	13	42	92	16	13
M12	95	13	28	65	16	13
M12	185	13	37	82	16	13
M12	240	13	42	92	16	13
M16	240	17	42	92	19	16

Booksize format devices

The directives when using cable lugs are provided in Booksize power units manual (<http://support.automation.siemens.com/WW/view/en/99687925>).

Index

A

- Active Interface Module, 139
- Active Interface Modules
 - Liquid-cooled, 166
- Active Interface Modules, air-cooled, 140
- Active Line Modules, 142, 167
 - Dimension drawing, 156, 180
 - Step-up factor, 165, 189

C

- Cable lugs, 194
- Commissioning the anti-islanding function, 123
- Connection example
 - Active Line Modules, 150
- $\cos\phi$ display, 45
- Crane lifting lugs, 183

D

- DC link precharging, 102
- Dimension drawing
 - Active Line Modules, 156, 180
- Displacement factor, 45
- Dynamic grid support, 40

E

- Electromagnetic fields, 14
- Electrostatic sensitive devices, 15

F

- Fan voltage
 - Active Line Modules, 158
- Function module dynamic grid support, 40
- Function module for grid droop control, 36
- Function modules for a micro grid, 24
- Function modules for an island grid, 23
- Function modules for the line infeed, 29
- Function modules for the power grid, 22
- Fundamental safety instructions
 - SINAMICS hardware, 11

G

- Grid control, 36
- Grid infeed applications, 33
- Grid monitoring anti-islanding, 43
- Grid-friendly transformer magnetization, 34, 102

I

- Identification of the transformer data, 35
- Installation
 - Active Line Modules, 183
- Interfaces
 - Active Line Modules, 148, 172
- Island grid, 23

L

- LEDs
 - Active Line Modules, 155, 155, 179, 179
- Line filter and transformer monitoring, 35
- Line Modules
 - Active Line Modules, 142, 167
- Line transformer function module, 34
- Line-side power components
 - Active Interface Module, 139
 - Active Interface Modules, air-cooled, 140
 - Active Interface Modules, liquid-cooled, 166

M

- Magnetization, 102
- Microgrid, 24

O

- Overload capability of Active Line Modules, 164, 188
 - High overload, 164, 188

P

- Power generation
 - With rotating machines, 19
 - Without rotating machines, 20

Power grid, 21
Protection guard, 184

R

Residual risks of drive systems, 17

S

Safety instructions
 Active Line Modules, 145, 169
 Electromagnetic fields, 14
 Electrostatic sensitive devices, 15
 General safety instructions, 11
Step-up factor, 165, 189

T

Technical data
 Active Line Modules, 160, 186
Transformer magnetization, 34

V

VSM topology, 102

Siemens AG
Process Industries and Drives
Large Drives
Postfach 4743
90025 NÜRNBERG
GERMANY

Subject to change without prior notice
© Siemens AG 2011 - 2015

www.siemens.com/drives